



OUR ROOTS RUN DEEP. SINCE 1918

How to Build a Raised Bed with Benches



This raised bed structure makes gardening easier and more comfortable. Cut the lumber yourself if you have some woodworking experience, or make it easy by having the boards pre-cut at a home improvement store. Be sure to choose a level piece of ground in a well-drained area that gets at least 6 to 8 hours of sun per day. To help prevent weeds, cover the ground inside the bed with newspaper or landscaping cloth before filling with potting soil.

DETAILS

Design by Chris Hill

Estimated Time: 4 hours*

** less if you have wood pre-cut*

Difficulty: Moderate

Approximate Cost (not including soil or plants): \$95 if using treated lumber, \$250 if using cedar

List of Materials:

- 1 – 2 x 2 x 8 board
- 3 – 2 x 4 x 8 boards
- 8 – 2 x 6 x 8 boards
- 2 – 2 x 8 x 8 boards
- 3 – 1-lb boxes 2½-inch deck screws
- 1 – 1-lb box 3-inch deck screws

List of Tools:

- miter saw or circular saw*
- drill/driver
- clamps
- square
- measuring tape

** or can have lumber pre-cut at home improvement store per dimensions in Parts List*

Parts List (see Cutting Diagram below):

Part	Quantity	Size
Side Slats	8	1½ x 5½ x 45
Bottom Side Slats	4	1½ x 7¼ x 45
Inner Posts	8	1½ x 3½ x 14
Bracket Supports	4	1½ x 5½ x 16
Brackets	8	1½ x 5½ x 15½
Outer Posts	4	1½ x 3½ x 16½
Seat Slats	8	1½ x 5½ x 24
Seat Cleats	4	1½ x 1½ x 20½

HOW-TO INSTRUCTIONS

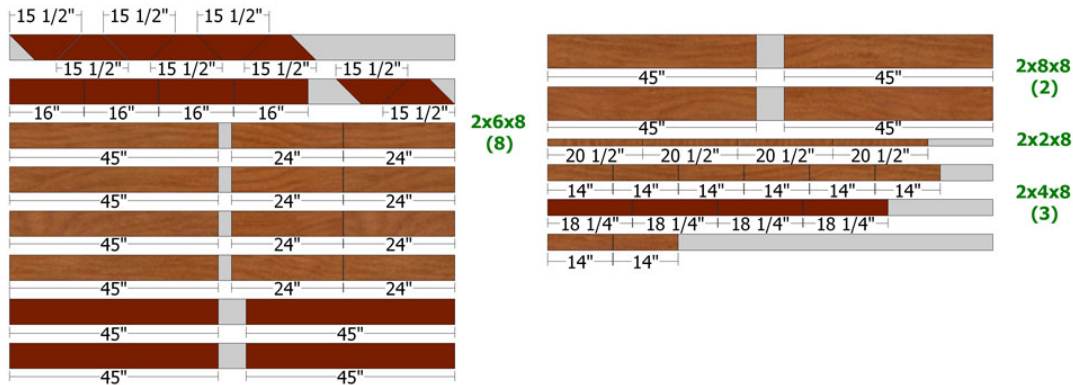

Cutting Diagram

Use the **Parts List** and **Cutting Diagram** as references for part dimensions. Cut the parts as needed for each step.

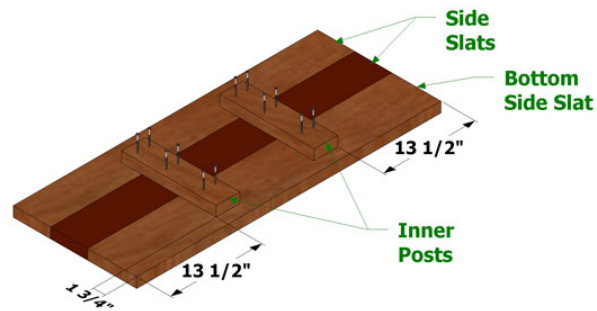

Figure 1

Create the **Side Assemblies** by positioning two **Side Slats** and one **Bottom Side Slat** with the ends flush. Place two **Inner Posts** 13½ inches from the ends and 1¾ inches from the edge of the **Bottom Side Slat**, as shown in **Figure 1**. Attach using 2½-inch deck screws. Repeat to create three more assemblies, using two **Side Slats**, one **Bottom Side Slat** and two **Inner Posts** for each. Divide the four assemblies into two sets of two.

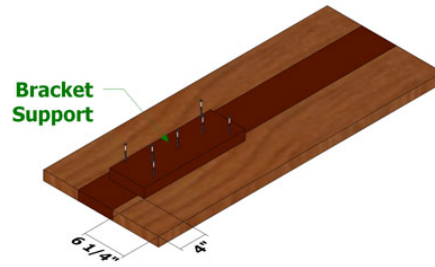

Figure 2

With one set of **Side Assemblies**, position a **Bracket Support** on each as shown in **Figure 2** and attach using **2½-inch deck screws**.

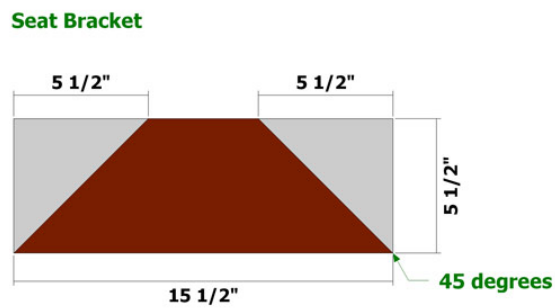

Figure 3

Use **Figure 3** as a guide for creating/identifying the **Brackets**.

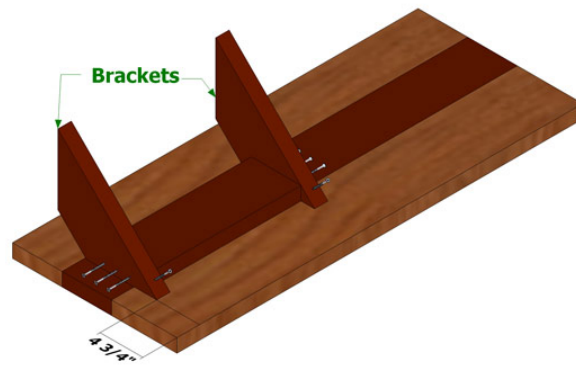

Figure 4

Still working on the first set of **Side Assemblies**, position the **Brackets** as shown in **Figure 4** on each, making sure they are flush against the ends of the **Bracket Support**, and attach using **2½-inch deck screws**.



Figure 5

Working from the opposite sides of these **Side Assemblies**, drive **2½-inch deck screws** through the **Side Slats** and into the **Brackets** on each as shown in **Figure 5**.

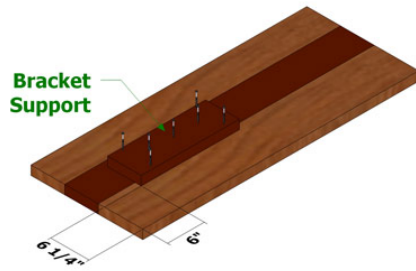

Figure 6

With the second set of **Side Assemblies**, position a **Bracket Support** on each as shown in **Figure 6** and attach using **2 1/2-inch deck screws**.

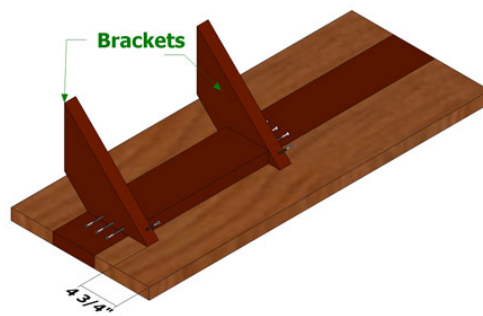

Figure 7

Position the **Brackets** as shown in **Figure 7** on each, making sure they are flush against the ends of the **Bracket Support**, and attach using **2 1/2-inch deck screws**.



Figure 8

Working from the opposite sides of these **Side Assemblies**, drive **2 1/2-inch deck screws** through the **Side Slats** and into the **Brackets** on each as shown in **Figure 8**.

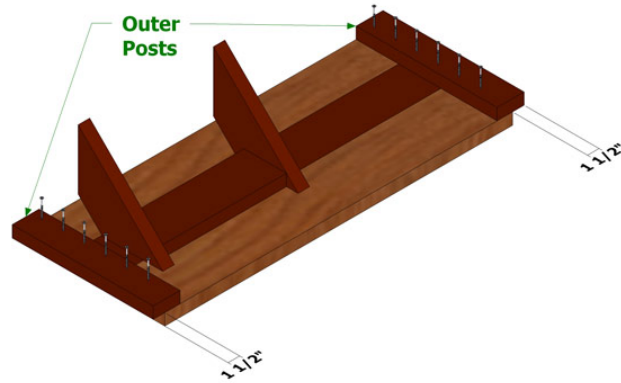

Figure 9

Flip this second set of **Side Assemblies** back over and position the **Outer Posts** on each as shown in **Figure 9**, then attach using **2½-inch deck screws**.

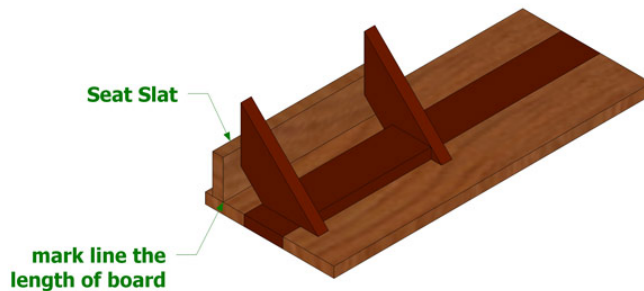

Figure 10

Working with the set of **Side Assemblies** without the **Outer Posts**, position a **Seat Slat** on each, flush against the end of the **Side Slats** and against the **Brackets** as shown in **Figure 10**. Mark a line where the **Seat Slat** meets the **Side Slat**.

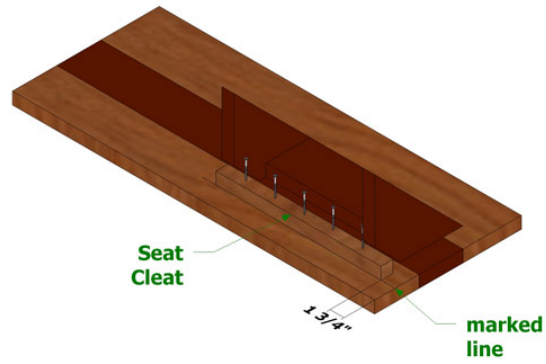

Figure 11

Position a **Seat Cleat** on each as shown in **Figure 11** (on the marked line) and attach using **2½-inch deck screws**.

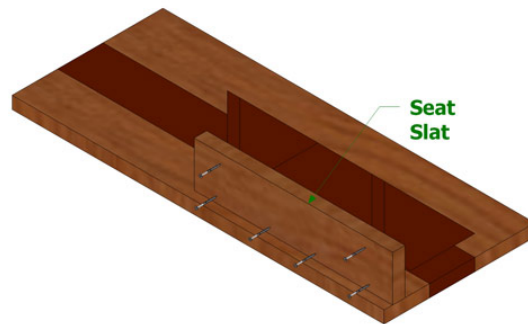

Figure 12

Position a **Seat Slat** on each as shown in **Figure 12** and attach to the **Seat Cleat** and **Brackets** using **2½-inch deck screws**.

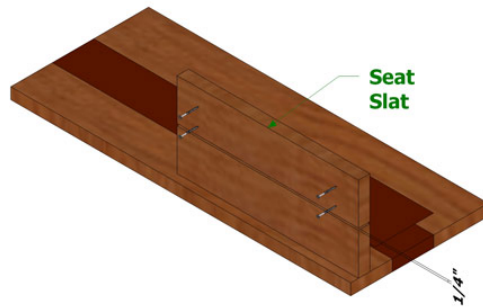

Figure 13

Position a second **Seat Slat** on each as shown in **Figure 13** and attach to the **Brackets** using **2 1/2-inch deck screws**. (Use a quarter-inch scrap piece as a spacer between the **Seat Slats** for this step, if desired.)

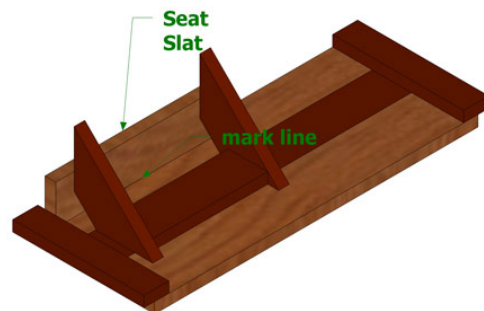

Figure 14

Working with the remaining set of **Side Assemblies** (with the **Outer Posts**), position a **Seat Slat** on each, flush against the end of the **Side Slats** and against the **Brackets** as shown in **Figure 14**. Mark a line where the **Seat Slat** meets the **Side Slat**.

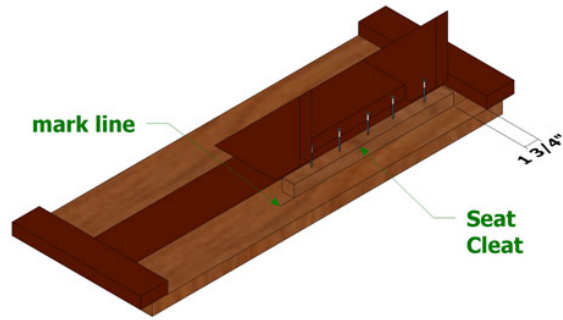

Figure 15

Position a **Seat Cleat** on each as shown in **Figure 15** (on the marked line) and attach using **2½-inch deck screws**.

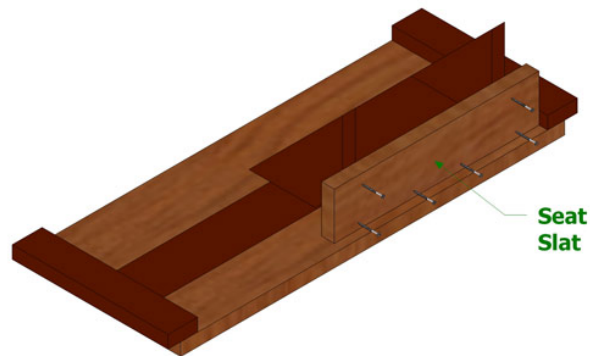

Figure 16

Position a **Seat Slat** on each as shown in **Figure 16** and attach to the **Seat Cleat** and **Brackets** using **2½-inch deck screws**.

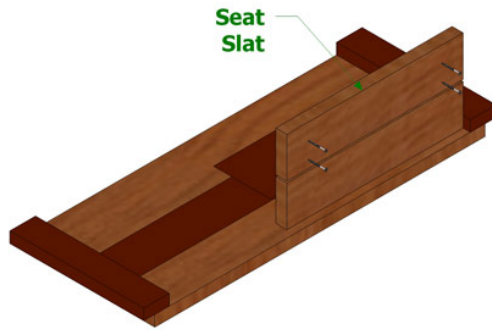

Figure 17

Position a second **Seat Slat** on each as shown in **Figure 17** and attach to the **Brackets** using **2 1/2-inch deck screws**. (Use a quarter-inch scrap piece as a spacer between the **Seat Slats** for this step, if desired.)

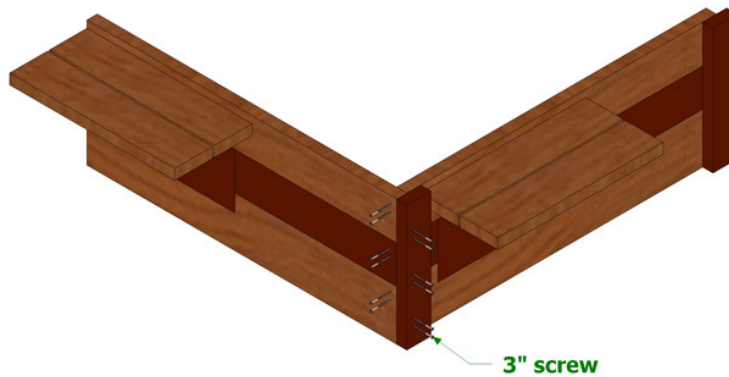

Figure 18

Position a side assembly without **Outer Posts** and a side assembly with **Outer Posts** as shown in **Figure 18**. Make sure the ends of the **Side Slats** fit flush against the **Outer Posts**. Attach using 3-inch deck screws. Repeat with the remaining pair of **Side Assemblies**.

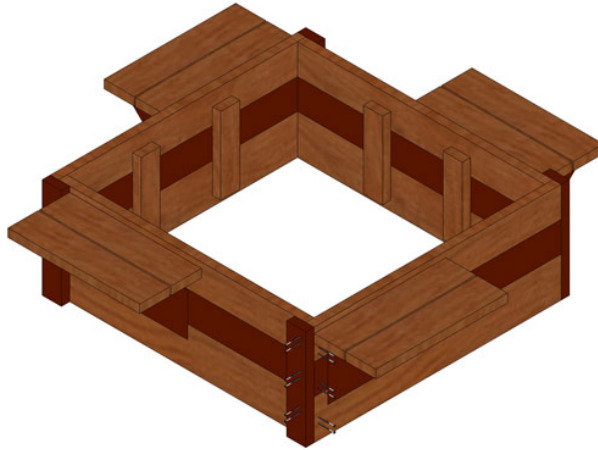

Figure 19

Position both pairs of **Side Assemblies** together as shown in **Figure 19**. Again, make sure the ends of the **Side Slats** fit flush against the **Outer Posts**. Attach using 3-inch deck screws.

Finished Dimensions:

Height: 18¼ inches

Length (not including benches): 48 inches

Width (not including benches): 48 inches

Length (including benches): 67½ inches

Width (including benches): 67½ inches