

Welsh route study

Long term planning process



Foreword	03
Executive summary	04
Chapter 1 – Strategic Planning Process	07
Chapter 2 – The starting point for the Welsh Route Study	10
Chapter 3 – Future demand for rail services - capacity and connectivity	15
Chapter 4 – Conditional Outputs - future capacity and connectivity	21
Chapter 5 – Choices for funders to 2024	40
Chapter 6 – Longer term strategy to 2043	50
Chapter 7 – Consultation and next steps	82
Appendix A – Appraisal Results	83
Appendix B – Mapping of choices for funders to Conditional Outputs	94
Appendix C – Stakeholder aspirations	97
Glossary	109

We are delighted to present the Welsh Route Study Draft for Consultation, which sets out the strategic vision for this part of the network over the next 10 to 30 years.

It is an evidence based study that considers demand entirely within the Wales Route and also between Wales and other parts of Great Britain.

The railway in Wales has seen a decade of unprecedented growth and our forecasts suggest that passenger numbers will continue to grow strongly during the next three decades, particularly in the south east of Wales and in the north east of Wales. Demand for rail freight is expected to evolve in response to changes in energy production and in response to growth in intermodal container traffic.

Every day the railway supports economic growth, reduces the environmental impact of the transport sector and improves the quality of life for people and communities. Wales relies on a safe and punctual railway and this Study sets out the industry's plan to meet future demand so that the railway continues to make a positive difference to the economy, to the environment and to people's lives.

Reducing long term subsidy and delivering value to taxpayers and funders are key considerations in this Route Study. The recommendations have been developed with the intention of optimising existing capacity first as this is the most efficient approach. Where this is not possible, the recommendations are based on enhancing the capacity or capability of the infrastructure so that more services can operate on the network.

These recommendations are presented as choices for the industry's funders to consider. We believe they are ambitious yet realistic and they reflect what can be done in a logical and sequential approach over the next 10 to 30 years. The potential for the Digital Railway to address capacity constraints and improve customer experience is included within the planning approach we have adopted.

This draft Study has been developed collaboratively with the railway industry and with funders and stakeholders. We would like to thank all those involved in the exercise, which has been extensive, and which reflects the high level of interest in the railways in Wales.

The engagement of the Department for Transport and the Welsh Government has been important in setting the policy context for the future of the railway in Wales.

This is a pivotal time for the railway in Wales with continuing growth in demand and a requirement to deliver value for taxpayers and customers. We welcome your thoughts, comments and suggestions regarding the industry's plans for meeting the growth in demand over the next 10 to 30 years.

Details about the process for providing feedback is in [Chapter 7](#), and the consultation period ends on 9 June 2015.

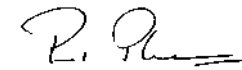

Paul Plummer
Group Strategy Director



Mark Langman
Route Managing Director, Wales



Highlights:

The Welsh Route Study Draft for Consultation is a key part of the rail industry's Long Term Planning Process (LTPP).

It sets out proposals and choices for funders for the next 10 to 30 years.

Introduction

These are exciting times for the railway in Wales with sustained growth in demand for rail services and investment from governments to enhance the capacity and the capability of the network.

This Welsh Route Study Draft for Consultation seeks to establish the required capacity and capability of the railway from a systematic analysis of the future requirements of the network. It seeks to accommodate the Conditional Outputs articulated in the Market Studies that are relevant to Wales and the Border Counties and, also, those developed in this Study. In doing so, it considers the safety, resilience and performance of the railway system and the imperative to provide value for money to taxpayers and funders.

Network Rail is developing a programme of Route Studies in conjunction with rail industry partners and other stakeholders. This programme of geographic Route Studies runs alongside the development of network-wide Route Utilisation Strategies, which review national issues such as stations, depots, alternative solutions, freight, rolling stock and electrification.

Scope

This Route Study sets out a strategy for the rail network in Wales and the bordering counties in England and, in doing so, it takes into account similar work in adjacent Route Study areas.

It considers passenger markets and freight markets and the important role these have in shaping the economy within the Study area.

A recent development in South East Wales is the emergence of the Metro integrated transport system which is being led by the Welsh Government and the Cardiff Capital City Region Board. The timing of this Route Study has provided the opportunity to consider the role that rail can play in the potential transport model of the future.

This Route Study does not specifically consider new lines unless they are a potential solution to accommodating the identified Conditional Outputs, and meet affordability and value for money criteria.

Timeframe and Baseline

The Welsh Route Study focuses in detail on Control Period 6 (CP6) between 2019 and 2024 and, also, sets out a longer term vision for the next 30 years to 2043.

As a starting point, the baseline for the Study is the committed interventions in CP5 (2014-19) which represent a transformation of the railway in parts of Wales and the biggest investment since the Victorian era.

It is intended that the final Route Study will be published in summer 2015. This means the choices for funders identified will inform the content of the Initial Industry Plan (IIP) for CP6 in 2016 and, ultimately, inform the Department for Transport's High Level Output Specification (HLOS) for the same period. The choices for funders will help inform the preparation for the next Wales and Borders franchise in 2018 and will also inform investment decisions by other funders, including the Welsh Government which has been involved in the development of this Study.

The longer term vision is intended to inform policy decisions where there is a line of sight between now and the next 10 to 30 years.

Process

The starting point for this Route Study Draft for Consultation is the Market Studies published in October 2013, and established by the Office of Rail Regulation in December 2013. The Market Studies forecast demand for passenger and freight traffic, and propose service level Conditional Outputs for the industry to meet subject to feasibility, affordability and value for money.

This Route Study also established additional Conditional Outputs that are relevant to Wales and the border counties in England.

Detailed demand forecasting analysis has been undertaken to ascertain the expected amount of growth over the next 10 and 30 years. The analysis identifies the gaps between supply and demand over 10 and 30 year time horizons and how this can be addressed through interventions. Where possible, the first principle is to optimise the use of the existing network prior to considering infrastructure interventions and this is evident as some of the choices for funders relate to additional train lengthening solutions.



The Conditional Outputs for this study include:

- the level of rail capacity required to accommodate the demand for passenger journeys and freight services
- the level of rail connectivity between key economic centres across the country (the frequency of train services, journey times, the provision of direct journeys which do not require an interchange).

This Route Study has been developed as a result of considerable analysis and close collaboration between Network Rail, governments, train and freight operating companies, with valuable input also received from regional and local authorities in Wales and the English border counties and community and rail user groups.

The Office of Rail Regulation has acted as an observer.

Choices for funders in CP6 (2019-24)

The choices identified and appraised as part of the Welsh Route Study are summarised in [Table 1](#) with a more detailed account in [Chapter 5](#).

Further work may be required in some cases to identify additional benefits in order to demonstrate the case for investment.

In all cases, where support exists from funders to progress a particular option, Network Rail will need to complete further engineering feasibility to ensure sufficiently detailed cost estimates, output definitions and delivery plans can be submitted as part of the business planning process for CP6.

All cost estimates published in this Study should be regarded as a high level guide only at this stage and are subject to change.



Table 1: Choices for funders in CP6

No.	Choices for funders in CP6	Conditional Outputs delivered
1	Provision of additional passenger capacity on Cardiff Valley Lines services during peak periods and associated platform lengthening	Capacity
2	Phased programme of further network enhancements on Cardiff Valley Lines and development of Cardiff Capital City Metro proposals for rail	Capacity & Connectivity
3	Line speed upgrade on Relief Lines between Severn Tunnel Junction and Cardiff	Capacity & Connectivity
4	Enhancement of Cardiff Central Station to create a station fit for a capital city	Capacity & Connectivity
5	Programme of level crossing closures in west Wales	Connectivity
6	Continuation of additional peak services on Heart of Wales line	Connectivity
7	Train lengthening on selected Marches Line services between Cardiff and Manchester	Capacity
8	Modernisation of the North Wales Coast Main Line between Crewe and Holyhead	Connectivity
9	Improved line speeds on North Wales Coast Main Line	Connectivity
10	Development of new interchange station at Shotton	Connectivity
11	Further network capacity enhancements between Wrexham and Chester	Connectivity
12	Improved line speeds between Wrexham and Bidston for connections to Liverpool	Connectivity
13	Continuation of additional peak services on Cambrian line	Connectivity

digital railway

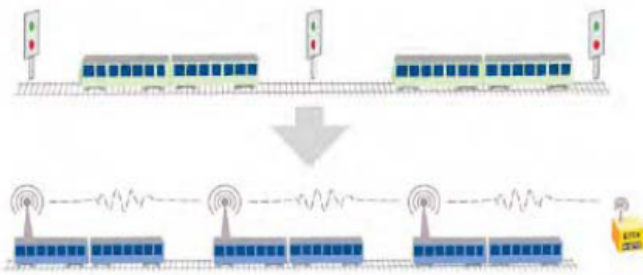

Digital Railway

The Digital Railway programme is being developed by Network Rail and rail industry partners. The programme is seeking to accelerate the introduction of new technology on the national network and, in particular, to accelerate the roll out of European Train Control Systems (ETCS) / Automatic Train Operation (ATO).

This work is still in early development and, at this stage, it is still possible to draw some initial conclusions about the potential benefits of this technology in the Welsh Route Study area in terms of meeting future demand that could otherwise require a major infrastructure intervention. These could be:

- providing more capacity or more flexibility on the Cardiff Valley Lines network
- providing more capacity and flexibility on the South Wales Main Line between Swansea, Cardiff, Newport and Bristol
- supporting the Cardiff City Region Metro initiative in terms of the integration of ticketing, tariffs and customer information.

Longer Term Strategy

This Route Study highlights a number of longer term options to meet demand and improve connectivity up to 2043. These represent interventions over and above those already identified for CP6. It may also be the case that some of the choices for funders in CP6 may not be deliverable or affordable in that timescale, or they may evolve further, and these could therefore become longer term interventions. Equally, funders may wish to consider accelerating the delivery longer term choices into shorter term timescales.

The longer term strategy builds on the choices set out for funders in CP6 and will provide strategic input to Network Rail's plans to modernise the railway network in Wales and the bordering counties over the next 30 years. Details of this strategy, presented geographically, can be found in [Chapter 6](#).

Acknowledgements and Next Steps

Planning the future of the network for the next 10 to 30 years is a privilege and is an important responsibility. The development of this Welsh Route Study Draft for Consultation has been made possible through close collaboration with funders, customers and stakeholders.

Network Rail is grateful to the following funders and industry partners - Welsh Government, the Department for Transport, Arriva Trains Wales, Arriva Cross Country, DB Schenker, First Great Western, Freightliner, GB Railfreight, Rail Delivery Group and Virgin Trains. We are grateful to other important stakeholders who have contributed to the strategy - local authorities, Hereford Local Enterprise Partnership, Rail Freight Group and community rail groups.

The consultation process is open until 9 June 2015 and Network Rail would welcome views, ideas and other feedback on the strategy and choices presented in this Study.

Details about the consultation process can be found in [Chapter 7](#).

01: Strategic Planning Process

Highlights:

This Route Study sets out the future direction for the railway in Wales

It has been developed through collaboration between the rail industry, funders and stakeholders

It details the governance, structure and scope of the Welsh Route Study

It sets out the strategic priorities and strategic goals that underpin this study

Figure 1.1: A collaborative process



1.0 Context

The railway in Britain has seen a decade of unprecedented growth and this is set to continue. Wales is a great example of this success where there is strong growth and significant investment from the railway industry, UK Government, Welsh Government and the European Funding Office.

This growth has been driven by a number of different factors. Socioeconomic changes have a big role to play and have changed the way we live, work and commute. Advances in communications technology means people have wider social networks and are inclined to travel further to meet friends or to enjoy leisure time. The cost of car ownership and the impact of congestion means more people rely on rail. The rail industry has also played a key role in making train services an attractive way to travel through expansion, market segmentation and technology driven changes in ticketing, tariffs and information.

The railway industry has a responsibility to understand these drivers of growth and how they interact with each other. This understanding is important to inform the future direction of the railway network.

Continuing this success story requires an evidence based and collaborative approach to strategic planning. This approach underpins the work of this Route Study and the resulting choices for funders.

1.1 Planning Approach

The railway in Wales and the Borders is a critical part of the rail network in Great Britain and the strategic planning process that underpins this Route Study reflects this. It has been developed as part of the Long Term Planning Process (LTPP), which updates the previous Route Utilisation Study (RUS) process, to plan the future of the network for the next 10 to 30 years, and provides choices for funders to build on the success story.

This Route Study has been completed through collaboration with the rail industry, funders in UK Government and Welsh Government and, critically, with stakeholders within Wales and those in the English border regions.

It is a collaborative process and Network Rail is privileged to lead this on behalf of the railway industry in Wales.

1.2 Relationship with Long Term Planning Process

This is one of a number of Route Studies that are being developed across the country and will inform the planning process for Control Period 6 (CP6) and beyond.

It builds on the four Market Studies that are fundamentally important precursors to the Route Studies. The Market Studies identified strategic goals, built up demand forecasts and developed Conditional Outputs for future rail services across the country. These covered the following markets :

- Long distance passenger markets
- London and South East passenger markets
- Regional urban passenger markets
- Freight markets

Web links to these Market Studies can be found in [Section 1.7](#).

1.3 The Cross-Boundary Approach

Many of the passenger and freight services that have been assessed in this Route Study operate across one or more Route Study boundaries. A common set of planning assumptions is required where this is the case, and in particular where some Route Studies are developed at a later date. Therefore as part of the LTPP, a Cross-Boundary Working Group has been established, which consists of Network Rail and passenger and freight operating companies, whose broad remit is to review planning assumptions used in each Route Study and provide advice on resolving capacity issues that might affect more than one Route Study area.

This group has also developed a cross-boundary Indicative Train Service Specification (ITSS) for passenger services which cross Route Study boundaries across Great Britain. This specification is an interpretation of how the connectivity Conditional Outputs articulated in the established Market Studies could be delivered. Additionally, the Freight Market Study has identified freight service requirements for each route nationally.

The Cross-Boundary Working Group will continue to meet as and when required for the duration of the national Route Study programme.

The Welsh Route Study area is served by a number of ‘cross-boundary’ services, all of which are included within the Welsh 2043 ITSS (see [Section 4.5](#)). Additionally, the Freight Market Study has identified freight service requirements for every route in Great Britain.

1.4 Governance Process

The governance arrangements that underpin this Route Study have enabled a collaborative and challenging process, and the structure is shown in [Figure 1.2](#).

The **Rail Industry Planning Group** sets the overall direction for the LTPP and involves representatives from governments, the Office of Rail Regulation (ORR) and the rail industry.

The **Wales Rail Industry Leaders’ Group** comprises representatives from governments, ORR and the rail industry within Wales. It has oversight of the development of this Route Study and has ensured that it has been completed in a collaborative, challenging and ambitious manner.

The **Working Group** is at the heart of this Study. It comprises of representatives from the passenger and freight operators across the route, the Department for Transport (DfT), Network Rail, Welsh Government, and ORR as an observer. It has developed demand forecasts for the next 10 to 30 years, planned the ITSS and assessed the solutions that have become choices for funders.

The **Regional Groups** have provided valuable input. Listening to, and understanding the priorities of these stakeholders has enriched this Route Study so that it has balanced regional economic priorities alongside those for the national economy.

The **Technical Group** comprises Network Rail asset managers and project delivery teams who have helped develop the Conditional Outputs.

1.5 Strategic goals and priorities

This Route Study sets out a vision for the next 10 to 30 years of a much busier railway – more customers, more journeys, more trains and faster speeds. The railway will need to be better every day, safer every day, and will need to satisfy more passengers more often. This is our challenge.

The LTPP considers the role that rail can play in delivering the following strategic goals of the transport sector:

- enabling economic growth
- reducing carbon and the transport sector’s impact on the environment
- improving the quality of life for communities and individuals
- improving affordability and value for money.

The strategic priorities that underpin this Route Study are:

- **Safety** – to ensure all our customers, staff and suppliers get home safe every day. This is central to the future interventions we are proposing as choices for funders.
- **Economic growth** – the railway is integral to the economy and thus a better railway is pivotal in delivering a better Great Britain. Rail has a big role to play in Wales where gross value added (GVA) per person is around 72 per cent of the national average.
- **Social value** – the railway is crucial in supporting local economies by providing access to employment, education and other social infrastructure as well as the retail and tourism sectors.
- **Digital Railway** – the rail industry’s Digital Railway blueprint will revolutionise train control, ticketing, tariffs and information (see [Section 1.6](#)).
- **Capacity** – longer trains and increased frequency of train services to accommodate growth in passenger numbers will require the capability of the railway to be enhanced.

Figure 1.2: Welsh Route Study governance arrangements

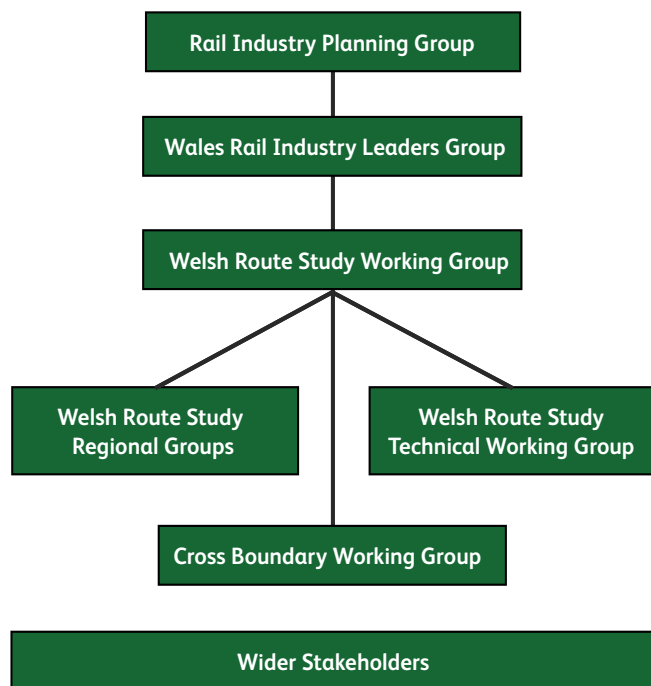

- **Connectivity** – the role rail can play in connecting communities and making interchanges easier and more reliable, both between trains and between trains and other modes. Connectivity with High Speed Two (HS2) is a key economic driver in the future and this Route Study has considered the opportunities at Birmingham and for further connectivity.
- **Punctuality** – more needs to be done to get customers to their connections or destinations on time. The railway system will be much busier and the industry needs to plan for this.
- **Weather Resilience** – future proofing the railway system from the worst effects of climate change is crucial to future plans.

1.6 The Digital Railway

The Digital Railway is a rail industry-wide programme designed to benefit Great Britain's economy by accelerating the digital enablement of the railway.

The scope of the Digital Railway is being developed in CP5.

The Digital Railway programme is setting out to build the industry business case to accelerate the digital enablement in several key areas of the railway, namely:

- **Train operation** – transforming the rolling stock landscape, tariffs, journey sale and settlement, and potentially even the franchise operating model. This is the 'Digital Train Operator'.
- **Capacity allocation** – long-term network planning through to sale of access to capacity in real-time. This is the 'Digital System Operator'.
- **Passenger** – simplifying journeys, from planning, purchase to on-the-day travel. This is the 'Digital Passenger'.
- **Infrastructure** – digital assets, digital workforce and digital Operations. This is the 'Digital Asset Manager'.
- **Stations and Interchanges** – retail and transport hubs with key interconnects to other modes of transport including driverless electric cars. This is the 'Digital Station'.

In most areas, work to develop technical capability is underway. The programme will seek to determine what is required to align and accelerate different initiatives to bring them into a single road map underwritten by the whole industry. The output of the programme will be a business case to Government, presented through the IIP in September 2016.

The Welsh Route Study assesses the role that future deployment of the European Train Control System (ETCS) might play in delivering enhanced network capability and capacity and this is set out in more detail in [Section 6.1.2](#).

1.7 Reference material

Information on other strategic planning documents can be found at:

www.networkrail.co.uk/asp/4449.aspx

Key documents include:

- Network RUS: Electrification
- Network RUS: Freight
- Network RUS: Passenger Rolling Stock
- Network RUS: Stations
- Network RUS: Alternative Solutions

More information on the Long Term Planning Process and the four established Market Studies can be found at:

www.networkrail.co.uk/long-term-planning-process/

Investment in Stations: A guide for promoters and developers can be found at:

<http://www.networkrail.co.uk/browse%20documents/rus%20documents/route%20utilisation%20strategies/network/working%20group%202%20-%20stations/investmentinstations.pdf>



02: The Starting Point for the Welsh Route Study

Highlights:

This chapter is about the baseline for the Route Study which includes all investment schemes planned for delivery in Control Period 5 (up to 2019)

It sets out the starting point for planning the future of the railway network in Wales

It details the current services and markets influencing the Route Study

The industry has plans to deal with existing capacity issues up to 2019

Figure 2.1: Growth in passenger journeys over the last 10 years

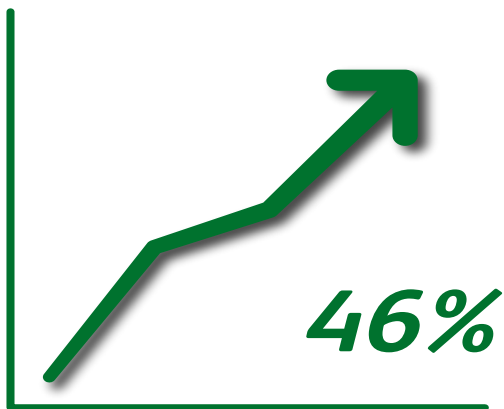

2.0 Context

The railway has come a long way in recent years and needs to build on what has been achieved as there is much more to do.

In Wales, there has been significant growth over the last 10 years with 46 per cent more journeys made and this keeps growing (see Figure 2.2).

Wales is well connected to the national network and there are strong cross-boundary markets for travel to and from England.

The railway is vitally important to the economy in Wales and the border regions. Funders and the railway industry have invested in more capacity and more services to meet growing demand. This is at the heart of the success story.

The railways in Wales serve different markets and this contributes to a rich and diverse baseline.

The geographical scope for the Welsh Route Study differs slightly

from that of Network Rail's Wales Route, and a map showing the geographical boundaries of the study can be seen in Figure 2.3.

The scope of the Welsh Route Study includes assessment of potential interventions to accommodate the Conditional Outputs identified in the Market Studies and this Welsh Route Study.

This Route Study does not assess potential demand for new stations which are either an aspiration of stakeholders or being promoted by third parties. Where these aspirations are known however, this Route Study does take a view on how these might accord with the longer term strategy and what impact, if any, they may have on future network capacity.

Additionally, this Route Study does not specifically consider new lines unless they are a potential solution to accommodating the identified Conditional Outputs, and meet affordability and value for money criteria. Where there are aspirations for new lines these are noted in Appendix C.

Figure 2.2: Demand for services within and to/from Wales

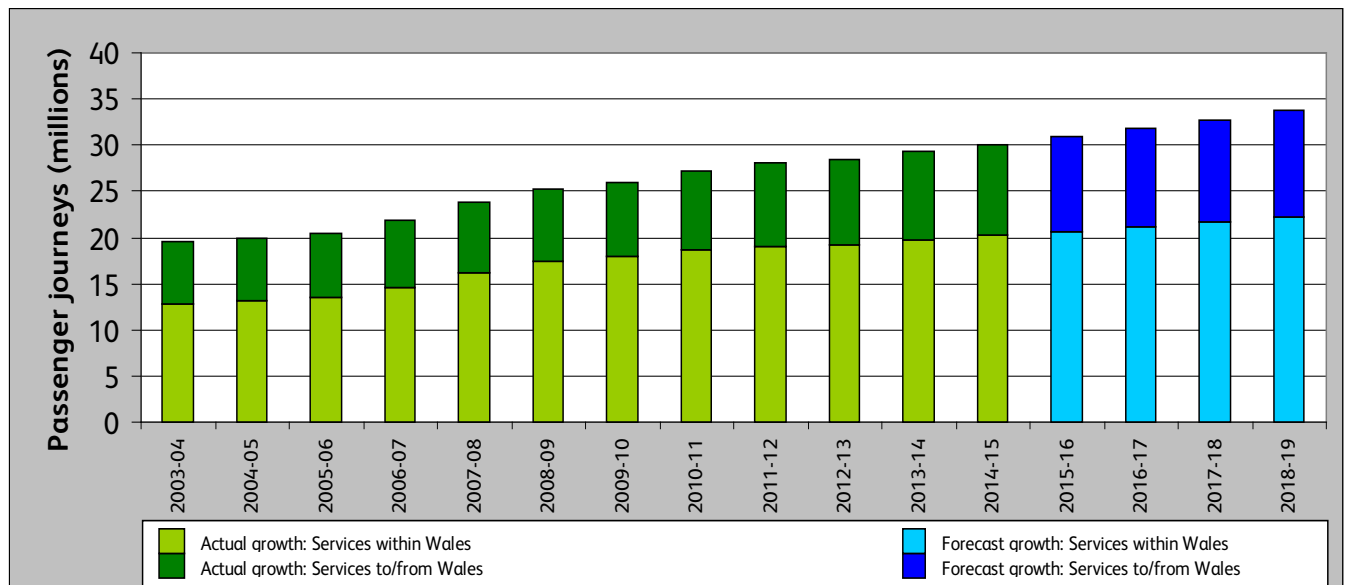
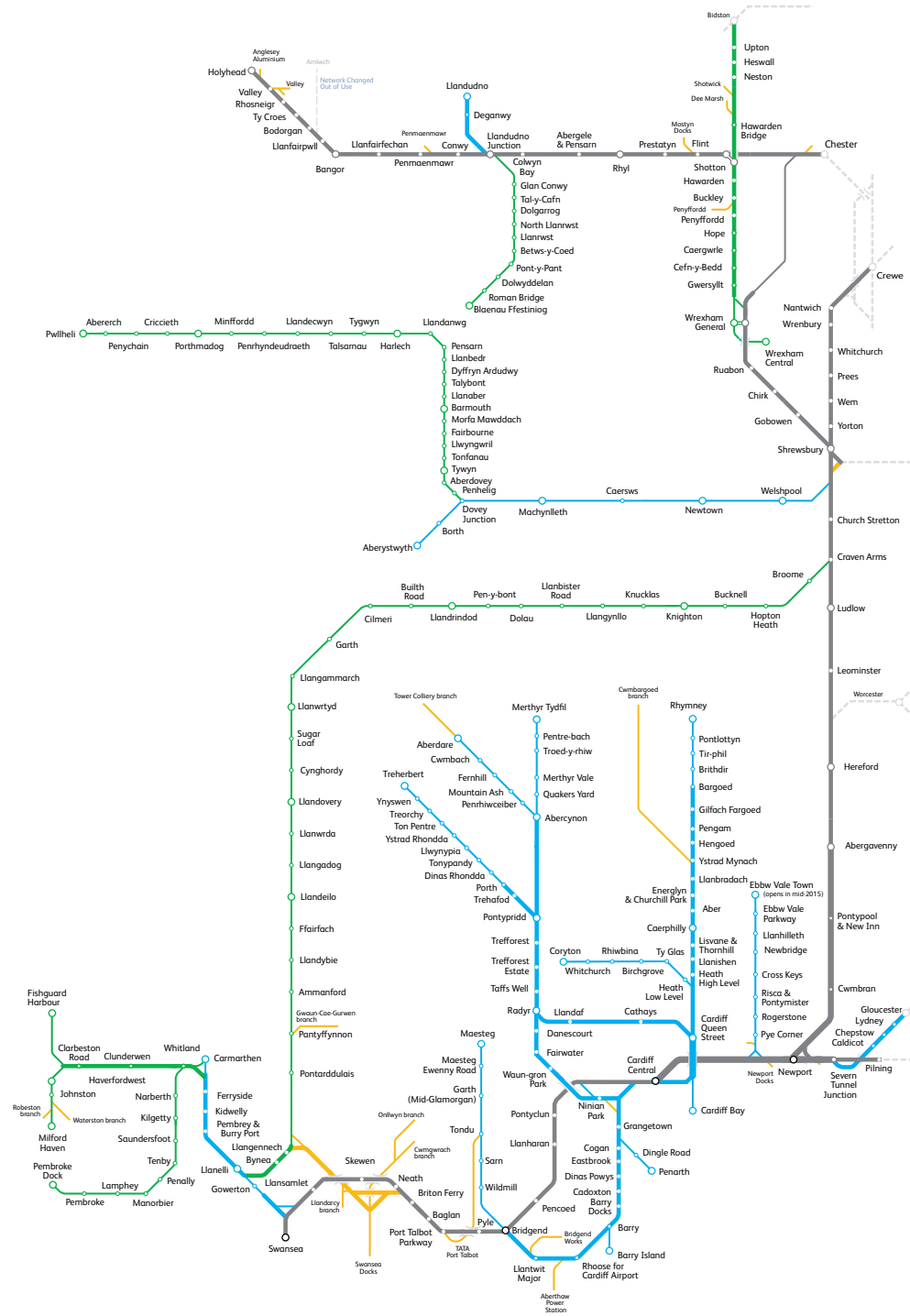

Figure 2.3: Welsh Route Study geographical scope



- Key**
- Primary
 - Secondary
 - Rural
 - Freight only

2.1 Services

2.1.1 Long Distance

This market is defined by distance of travel, usually greater than 50 miles, or by travel between large towns and cities at least 30 miles apart. The definition includes business and leisure journeys.

There are a number of strong and well established long distance markets between Wales and the wider network. A summary of the key long distance markets are below:

- South Wales to Birmingham and East Midlands
- South Wales to Thames Valley and London
- South Wales to south coast (Southampton, Portsmouth)
- South and West Wales to Shrewsbury, Crewe and Manchester
- North Wales to South Wales via Chester, Wrexham and Shrewsbury
- North Wales to Manchester and Liverpool via Crewe
- North Wales to London via Crewe, Chester and the West Coast Main Line
- Birmingham to Shrewsbury, Machynlleth, Aberystwyth and Pwllheli.

2.1.2 Regional Urban

This market relates to short distance travel to centres of economic activity, generally within a 50 mile radius from origin to destination. These journeys tend to be in areas of concentrated activity, such as city centres, where rail has a competitive advantage. Journeys are usually for the purposes of commuting, leisure purposes or shorter business journeys.

Rail has a strong role in the success of the economy and is a driver of new investment in creating jobs. Indeed, the busiest market of this type in Wales centres around Cardiff and is served by the Valley Lines network as well as longer distance services. This demonstrates the vital role that rail has in supporting economic growth in the banking, insurance and professional services sectors that are the backbone of the capital city's economy.



The success of the Valley Lines network highlights the direct relationship between the economy and the railway. The inner core of the network provides a typical turn up and go service while frequencies on the outer core are typically every 20 or 30 minutes. Demand for services is growing strongly year on year and crowding is currently an issue at peak times. The industry's plans for Control Period 5 (CP5), detailed in [Section 2.3](#), which include Valley Lines Electrification and infrastructure enhancements, will help address the crowding issue.

There are also strong markets between South Wales and Bristol via Severn Tunnel Junction, as well as flows into Swansea, Bridgend, Newport, Chester, Manchester, Liverpool via Bidston, Gloucester, Cheltenham and Birmingham.

2.1.3 Rural Services

Rural services typically serve areas of low population where people rely on these services for many different purposes. Typically they are often the only form of public transport in these areas and they tend to serve a number of different markets. Rural services are of particular importance to the economies of West Wales, Mid Wales and North West Wales.

An example is the largely rural Heart of Wales Line which serves different purposes – it is a commuter railway into Swansea and Shrewsbury, it is a leisure railway for visitors and tourists, and it fulfils an important social role for people and communities along the route.

Other rural railways have a similarly important role on the Cambrian Coast line, Blaenau Ffestiniog line, Fishguard line and lines to Pembroke and Milford Haven.

2.1.4 Freight Services

The transportation of freight by rail plays a key role in the supporting the UK economy and in removing many lorries from the congested road network. Freight also has a considerable socioeconomic impact on both a national and local scale. With 15 per cent of all UK rail freight originating or terminating in South Wales, and the core of this being the steel from Tata plants (such as Llanwern), freight has a notable impact upon Wales.

The South Wales Main Line, the North Wales Main Line and the Marches Line between Newport and Shrewsbury form the basis of the national freight network in Wales. This network supports the movement of freight from branch lines and a number of freight-only lines.

Steel, coal and petrochemicals are the predominant traffic in South Wales and there is also a moderate flow of container traffic between Cardiff and the Midlands and Southampton. In West Wales, the oil refineries near Milford Haven generate long-distance flows to Westerleigh and to Theale. The Central Wales Line is very occasionally used for freight diversionary purposes.

The RWE coal-fired power station at Aberthaw on the Cardiff Valleys network continues as a key power generator in Wales and it attracts traffic from a variety of sources, in South Wales including Tower Colliery, Cwmbargoed, Onllwyn and Cwmgwrach and also further afield from Avonmouth. Recent investment in the RWE Aberthaw facility to comply with current legislation has extended the life of this power station and means that freight traffic will continue at current levels in CP5.

The Vale of Glamorgan Line offers a freight diversionary route for the South Wales Main Line between Cardiff and Bridgend. The main traffic over the Swansea District Line is steel traffic to and from the Tata works at Trostre in Llanelli.

A service is operated for Tesco from Daventry to Wentloog in Cardiff, for fast-moving of consumer goods into the retailers regional distribution centre at Magor.

The Marches Line, between Newport and Shrewsbury, has experienced recent freight traffic growth and offers an alternative option to routing traffic to the north via the busier, steeply-graded Lickey route through Bromsgrove and Birmingham. The majority of the traffic is steel, scrap metal, coal, intermodal containers and aggregates. Traffic volumes on this route will continue to be high during CP5.

Steel traffic from Tata Llanwern in South Wales passes over the Marches Line via Shrewsbury and Wrexham (for Deeside). This route is also used by coal traffic from Portbury Docks (Bristol) to Fiddlers Ferry (Warrington) and Rugeley power stations. The principal driver

of freight traffic in North Wales is the Tata steelworks at Deeside.

Other traffic flows on the route include automotive flows from Ford's facility near Bridgend, timber flows to Chirk and Ministry of Defence (MoD) traffic in South Wales.

2.2 Depot and stabling arrangements

A new Intercity Express Programme (IEP) depot is being built at Swansea.

Currently the Wales and Borders franchisee operates out of depots and out-stabling facilities at Carmarthen, Cardiff Canton, Treherbert, Rhymney, Chester, Crewe, Machynlleth and Holyhead. The latter is also used by the West Coast franchisee.

There are freight train facilities at Margam, Cardiff Wentloog and Newport.

Access to most of these depots is satisfactory in terms of infrastructure and paths. However, access to Cardiff Canton is at near capacity because the access/egress points are configured as part of the Cardiff West Junction layout which is heavily utilised by timetabled passenger and freight services, and the option to relieve pressure by stabling more trains at Rhymney and Treherbert instead is constrained by the single line sections to and from these locations.

2.3 Committed schemes – those included in the baseline

The railway in Wales is benefitting from significant investment from funders in CP5 both in terms of rolling stock and infrastructure. As such the Welsh Route Study takes 2019 (the end of CP5) as the baseline for the study – assuming that all schemes committed in CP5 will have been delivered by that time. This investment includes schemes of both national and regional significance.

The baseline of this Route Study includes the following committed schemes:

Great Western Main Line Electrification from London to Swansea, and new IEP trains. Incremental gauge clearance to W12 is being assessed which includes the route between Bristol Parkway and Cardiff Central with an option to include Cardiff Central to Barry Docks. This is currently being developed to GRIP Stage 3.



Cardiff Area Signalling Renewal, with additional Welsh Government and European funding, providing additional infrastructure capacity for up to 16 trains per hour through the central core between Cardiff Central and Cardiff Queen Street during the peak. Enhancements include additional platforms at Cardiff Central, Cardiff Queen Street, Barry, Caerphilly and Pontypridd, as well as redoubling of the Trefforest Curve between Cardiff Central and Ninian Park, and a new passing loop on the single line at Tir Phil between Bargoed and Rhymney. The re-signalling additionally provides improved operating flexibility in the Cardiff Central area.

Valley Lines Electrification which enables more efficient and faster electric rolling stock to replace the existing diesel rolling stock. Electric passenger rolling stock will provide greater on-train capacity than the existing diesel passenger rolling stock. The delivery profile for this scheme is currently being updated.

Maesteg Frequency Enhancement Scheme which delivers infrastructure capability for two trains per hour to improve local connectivity and access to jobs.

Additional stations on the Ebbw Vale line at Pye Corner and an extension to Ebbw Vale Town. In addition Welsh Government has funded development into improving the frequency on the line from the current one train per hour. As this scheme is still in the development phase it has not been included in the 2019 baseline however it is likely that the scheme may be delivered before 2019.

North-South Journey Time Reduction Scheme between Shrewsbury and Chester via Wrexham, enabling faster journey time opportunities and some additional capacity.

Newport to Shrewsbury and North Wales Coast Phase 1 (Rockcliffe Hall to Llandudno) resigalling.



2.4 Weather Resilience of the network – building resilience to climate change into the Welsh Route Study

A safe, reliable and resilient network underpins our future plans for the railway. The resilience of the railway to extreme weather events is a considerable part of this and Network Rail asset policies and plans reflect this.

As in other parts of Great Britain, the extreme weather events in December 2013 and January 2014 caused disruption to parts of the network covered in this Route Study and there was an impact on local and regional economies, particularly in North Wales, West Wales and the Cambrian coast.

In September 2014, Network Rail published a series of Weather Resilience and Climate Change Adaptation (WRCCA) plans, identifying appropriate actions to increase weather resilience. The plans focus on improving or strengthening existing assets – e.g. scour protection and sea defences. There is a specific WRCCA plan for Wales.

The WRCCA plan for Wales sets out the plans, policies and actions that are in place to address resilience in the Welsh Route Study area. At this stage of the resilience planning process there are no proposals to consider alternative line scenarios in Wales. However, it is reviewed regularly and this subject area will be updated as appropriate in future strategic plans for Wales

2.5 Reference material

The Network and Route Specifications for the Wales Route, which publish the capability of the network, can be found at the following link:

www.networkrail.co.uk/Network_specification_Wales.aspx#map-8

Information about Network Rail's Weather Resilience and Climate Change Adaptation Plan for Wales can be found at the following link:

www.networkrail.co.uk/publications/weather-and-climate-change-resilience/

03: Future Demand for Rail Services - Capacity and Connectivity

Highlights:

A positive outlook for rail in Wales

High demand for commuting into Cardiff

Continued growth in demand for long distance and regional urban passenger markets

3.0 Context

This Route Study has assessed demand for the next 10 to 30 years in order to identify the long term priorities for rail.

The infrastructure and rolling stock components of the railway system have long asset lives and taking a 30 year planning horizon provides the opportunity to inform once in a lifetime investment decisions, starting with the opportunities that present themselves for Control Period 6 (CP6).

3.1 Passenger demand forecasts

3.1.1 Passenger priority flows

This Study has identified key growth corridors within the Welsh network, which are likely to require changes in capacity or capability to accommodate future demand. These flows are shown in [Figure 3.2](#)

As discussed in [Chapter 2](#), the majority of long distance journeys are made for the purposes of business on behalf of an employer and for leisure. Although long distance commuting is increasingly popular, the predicted growth of the long distance market continues to be driven by the needs of business and leisure passengers. Key priority flows identified for the long distance market are detailed in [Section 2.1.1](#).

The Regional Urban market, in particular commuting into economic centres, is expected to grow with employment and business opportunities. Given the distance between Wrexham and economic centres in North West England, more journeys are made between these locations to access jobs and business opportunities. Key priority flows for the Regional Urban market include:

- Commuting to Cardiff
- Commuting to Swansea
- Commuting from South Wales to Greater Bristol area
- Wrexham to cities in North West England

3.1.2 Long term demand scenario

A “scenario planning” approach is used to consider the range of societal outcomes that can occur over a long time period, and to estimate how rail passenger demand would likely to be influenced by these outcomes.

A series of potential alternative economic futures for Great Britain have been developed and these futures articulated as four scenarios in the established Market Studies (see [Section 1.2](#)), are detailed in [Figure 3.3](#) which describes the likely impact on the factors which influence rail and demand.

These four scenarios represent the four most likely combinations of the economic and social/environmental outcomes, but other future combinations may also be possible. The range of growth rate guides the development of schemes to 2023 and 2043.

The Route Study, and specifically its demand forecasts, uses the Prospering in Global Stability (PGS) scenario to identify future capacity requirements, presented in [Sections 3.1.4](#) and [3.1.5](#). This is to account for the greatest possible demand increases.

The Struggling In Isolation (SII) scenario is used to help understand risks associated with the choices of investments for funders if the economy is not going in the direction we planned for.

Figure 3.1: Forecast growth for commuting into Cardiff City Region

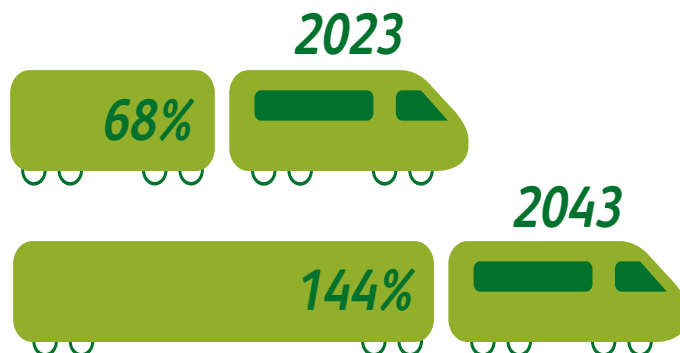

Figure 3.2: Key growth corridors and economic centres

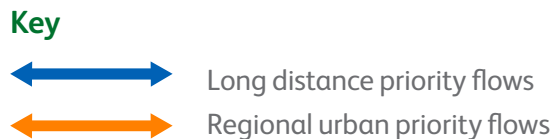
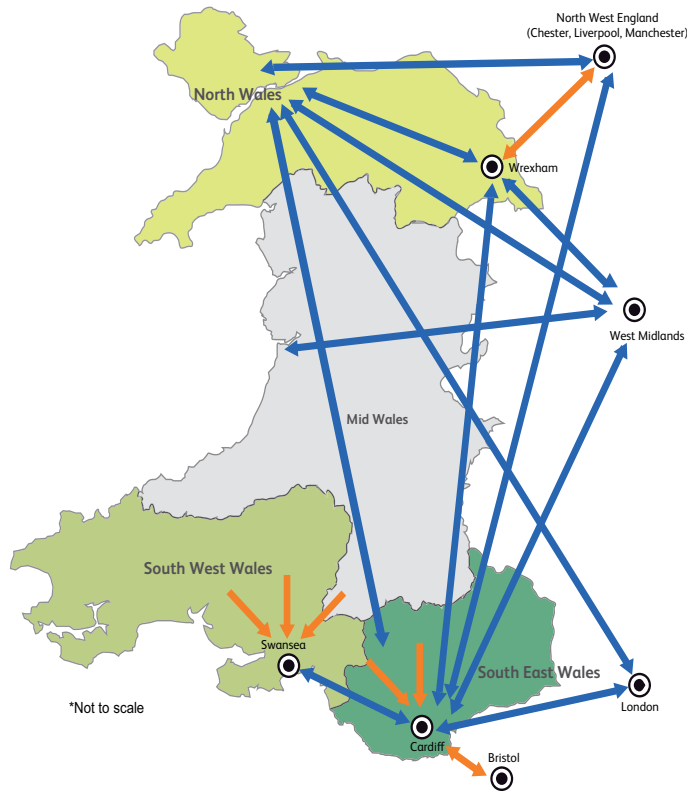
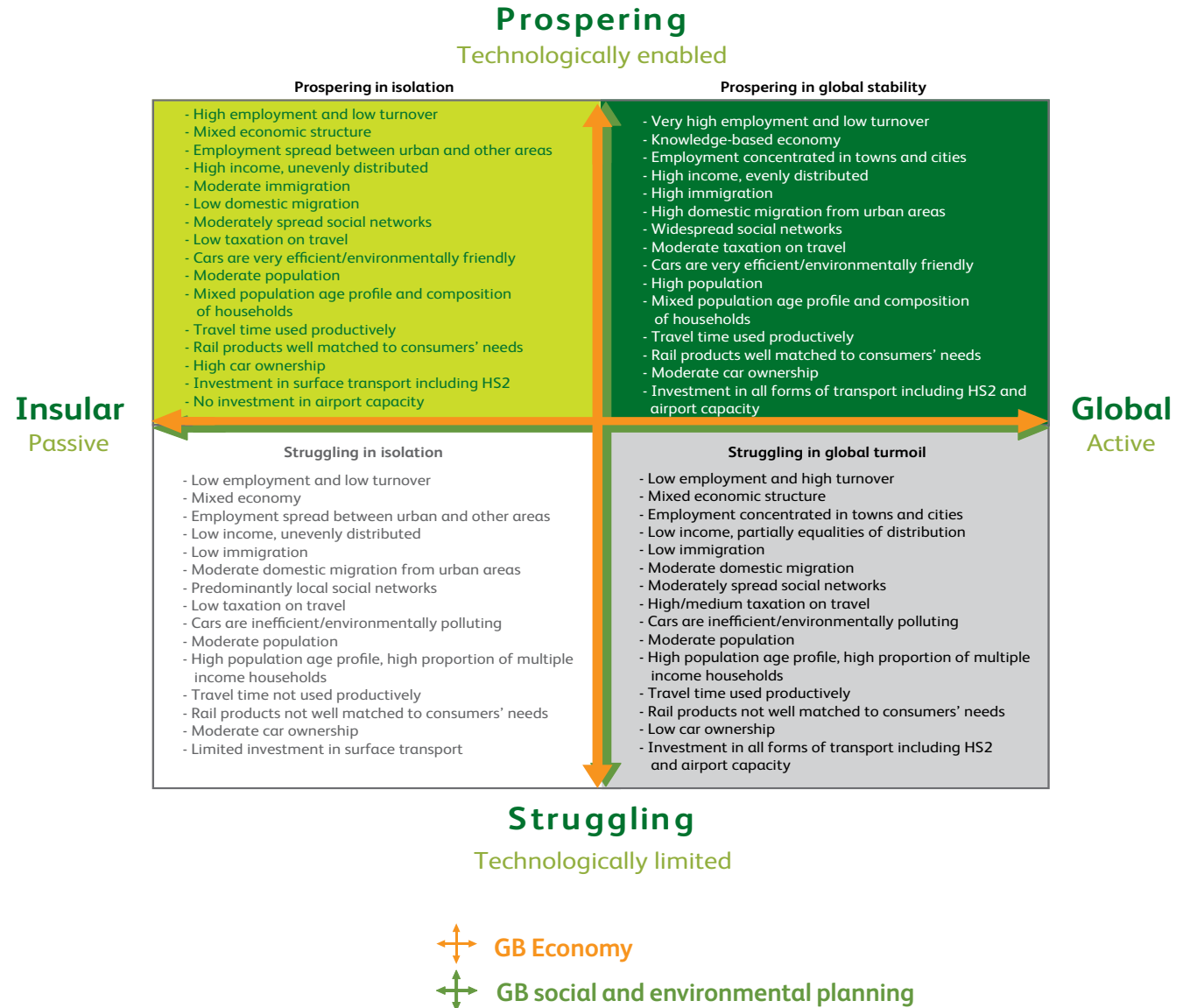

Figure 3.3: Impact of the long term scenarios on the factors which influence demand for rail



3.1.3 Demand modelling approach

The established Market Studies developed demand forecasts for various long distance and regional urban flows, some of which are to/from Welsh locations.

This Route Study has adapted these established demand forecasts to understand future capacity requirements.

At the same time, this Route Study has developed its own demand forecasts for those key flows that were not assessed in the four Market Studies. However, the same approach has been used for the purpose of consistency.

The future background growth of the rail market's size and share is primarily influenced by the following five factors:

- macro economic factors, such as distribution of employment, income and homes
- micro economic factors, such as the cost of travel by car and rail, car ownership, and competition between modes
- demographics, such as population, age of population and household composition
- consumer tastes, such as the use of travel time and travelling alternatives
- the supply of travel opportunities, such as rail generalised journey times and punctuality.

More details about these factors are documented in Chapter 6 of the Long Distance Market Study and Regional Urban Market Study, links to which can be found in [Section 3.3](#).

Local factors, such as land use changes and new developments, that affect demand on rail have been discussed within the Working Group and reflected in the background growth as appropriate.

Importantly the forecast also reflects the impact of the CP5 committed service improvements and has applied the changes as an overlay to the background growth.



3.1.4 Priority flows for the Long Distance market

The demand models used in the Long Distance Market Study have been used to develop forecasts for the Welsh Route Study's long distance priority flows, using population data updated since the study was published.

The demand forecast for flows between the North Wales Coast and Manchester is adapted from the Northern Route Utilisation Strategy published in May 2011, to ensure consistency with the work undertaken in the Northern Hub Analysis.

Estimated growth on the long distance market priority flows are presented in [Table 3.1](#).

Table 3.1 Growth in passenger demand for long distance priority flows from 2013-2023 and 2043

Flows between		Estimated growth*	
		2023	2043
London	Cardiff	34%	142%
	Swansea	28%	111%
	North Wales Coast	27%	151%**
North Wales Coast	Chester	12%	41%
	Manchester	16%	56%
	Liverpool	13%	44%
	West Midlands	16%	79%**
North Wales	South Wales	20%	77%
The Cambrian Lines	West Midlands	21%	78%

* based on the Prospering in Global Stability scenario (PGS)

** includes impact of HS2 phase 1 & 2

Figure 3.4: Passenger commuting flows into Cardiff

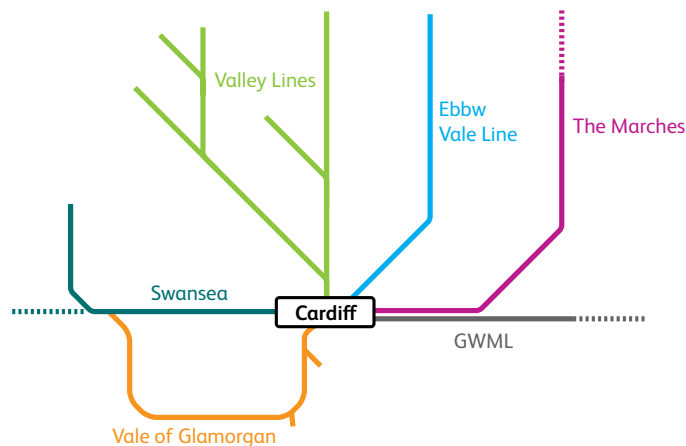

3.1.5 Priority flows for the Regional Urban market

The Regional Urban Market Study demand approach has been adopted to develop forecasts for the priority flows from Wales to other large UK economic centres.

Discussions with stakeholders during the Welsh Route Study helped to identify whether local factors, such as changes of land use, are expected to bring significant impact to future rail demand. The impacts of committed rail interventions before the end of CP5 are also considered.

3.1.5.1 Demand growth for commuting into Cardiff

Estimated growth on peak demand to Cardiff is shown in Figure 3.4 and Table 3.2.

The demand growth for commuting into Cardiff has taken into account the impact of the committed rail interventions in the Cardiff area, including the electrification of the Great Western Main Line (GWML) as far as Swansea, and introduction of Intercity Express Programme (IEP) trains, Valley Lines Electrification (VLE) and new stations on the Ebbw Vale Line. Details of these interventions are discussed in Section 2.3.

The impact from the committed interventions ranged from 7 per cent to 21 per cent depending on the corridor. Although future timetables are still in development, these impacts are indicative and estimated based on the latest timetables available. The new stations at Pye Corner (which opened in December 2014) and Ebbw Vale Town (opening in Summer 2015), serving the Ebbw Vale Line will contribute to significant passenger growth on the line.

3.1.5.2 Passenger demand growth for commuting into Swansea:

Estimated growth on peak demand to Swansea is shown in Figure 3.5 and Table 3.3. The growth for peak demand to Swansea has included the impact from the IEP which provides more capacity.

3.1.5.3 Growth in passenger demand from Wrexham

Estimated growth for flows between Wrexham and large economic centres in North West England are shown in Table 3.4.

Table 3.2 Passenger demand growth for commuting into Cardiff		
Corridor into Cardiff	Estimated growth*	
	2023	2043
Valley Lines	76%	153%
Vale of Glamorgan	80%	159%
Ebbw Vale Line	112%	205%
Swansea	56%	124%
GWML	46%	120%
The Marches	38%	96%

* based on the Prospering in Global Stability scenario (PGS)

Figure 3.5: Passenger commuting flows into Swansea

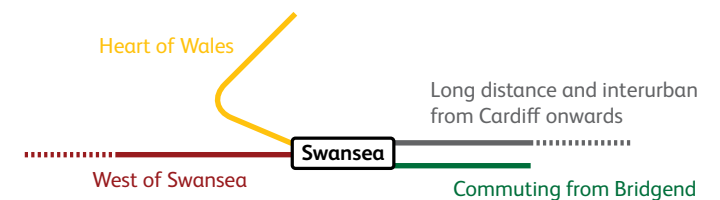

Table 3.3 Passenger demand growth for commuting into Swansea		
Corridor into Swansea	Estimated growth*	
	2023	2043
Heart of Wales	32%	90%
West of Swansea	24%	78%
Commuting from local stations	30%	87%
Long distance and interurban services	37%	97%

* based on the Prospering in Global Stability scenario (PGS)

Table 3.4 Passenger demand between Wrexham and North West England from 2013		
Flow between Wrexham and:	Estimated growth*	
	2023	2043
Chester	30%	88%
Manchester	27%	82%
Liverpool	27%	82%

* based on the Prospering in Global Stability scenario (PGS)

3.2 Freight demand forecast

Freight demand forecasts were developed for the whole of England, Scotland and Wales in the Freight Market Study. The Freight Market Study has produced demand forecasts for freight over a 10, 20 and 30 year planning horizon. The study includes preferred routing of services and the implied requirements in terms of network capacity and capability. Figure 3.6 shows the trend of growth for freight traffic in Wales.

The South Wales Main Line from Swansea to the Severn Tunnel is the primary freight route in Wales. This accounts for a relatively small proportion of the track miles in Wales and this means that the tonne kilometres are not as significant as the absolute tonnage moved might suggest. Key freight flows and sites are detailed in Section 2.1.4.

3.2.1 Metals

Metals are the most significant freight commodity in the Wales Route Study area. No change in the overall markets for metals (i.e. road and rail markets) is assumed.

Forecast growth in rail volumes are attributed to the improvements in the economics of rail used within the modelling work underpinning the Freight Market Study. The metals sector is dominated by a small number of steel producers. The potential for growth is intimately connected with their business decisions and the role of rail within their supply chains and logistics.

3.2.2 Petroleum

Petroleum represents the second largest commodity by tonne kilometres in Wales but is not forecast to grow substantially. No change in the size of the total market (i.e. road and rail) was assumed. Growth in rail volumes can be attributed to the improvements in the economics for rail. The forecasts do not account for the possibility of additional rail traffic resulting from modal shift from pipelines but do address modal shift from road to rail.

3.2.3 Electricity supply industry (ESI) coal and biomass

The Freight Market Study forecast for ESI coal is based upon the Department of Energy and Climate Change (DECC) projections. This assumes a decline in the use of coal, partially offset by biomass. The long term future of power stations consuming coal in Wales is not certain. Coal is either imported or produced in Welsh coal extraction sites. While the forecast assume a universal decline evenly across the entire network, in reality the trajectory will be determined by choices of individual power stations. There is therefore uncertainty about the extent and timing of the decline of ESI Coal transported by rail. More details can be found on specific assumptions in the Freight Market Study.

Figure 3.6: Wales freight forecast (net tonne km)

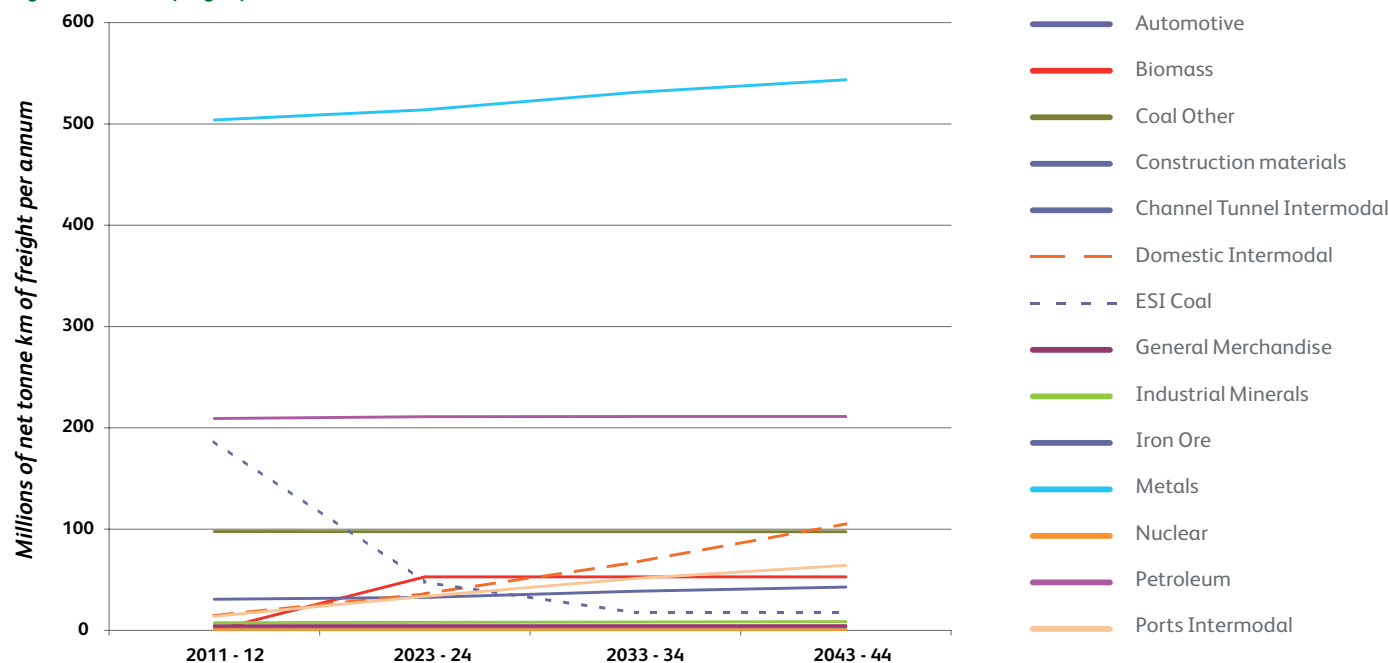
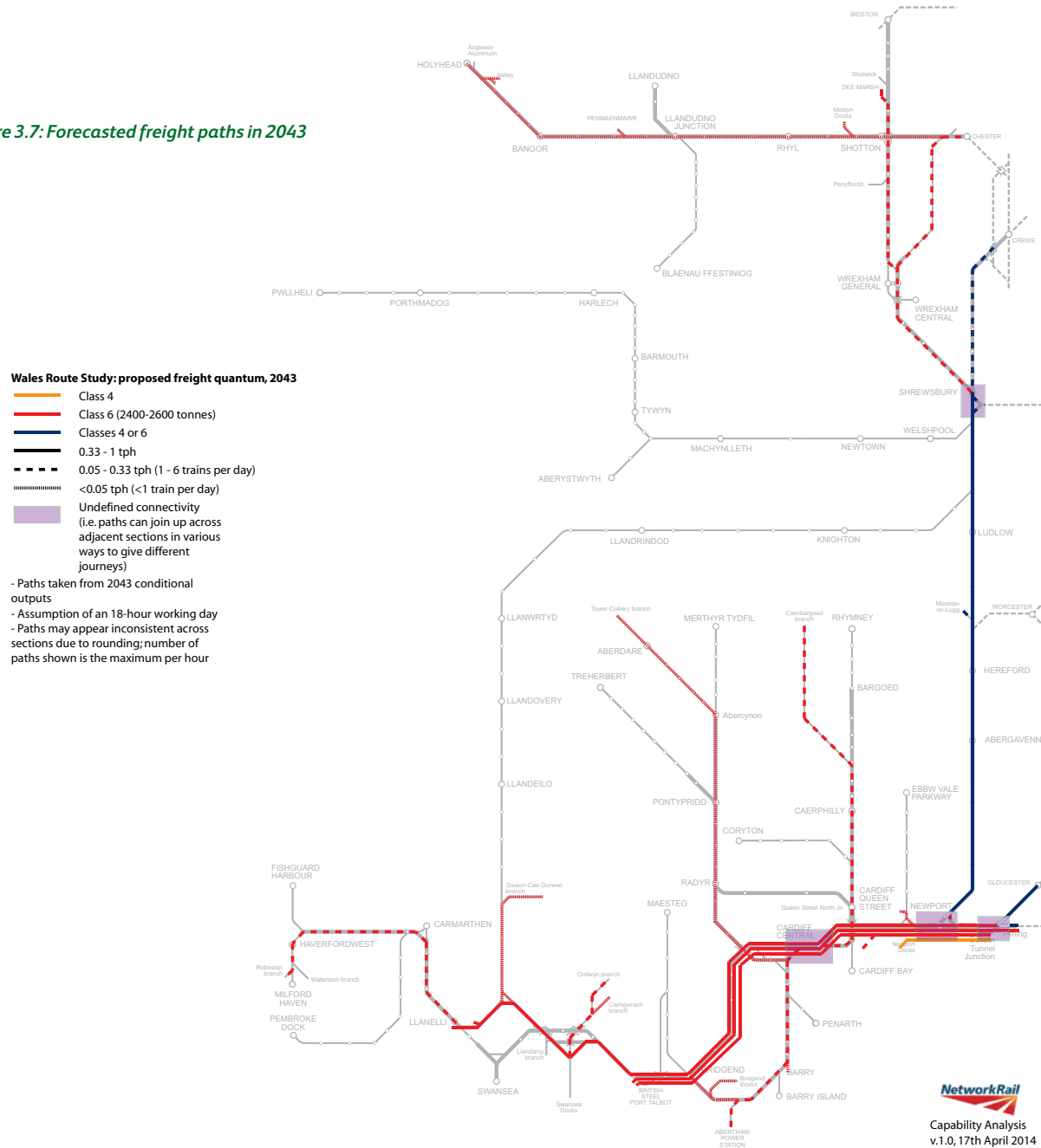

Figure 3.7: Forecasted freight paths in 2043



3.2.4 Ports and domestic intermodal

Ports and domestic intermodal do not represent large current net tonne kilometres. However, this is partly because Wentloog intermodal terminal (the only sizeable intermodal terminal in Wales) is between Cardiff and Newport. This means the distance run in Wales between the Severn Tunnel and Cardiff is a small proportion of the overall journey. Currently there are ports intermodal trains from Southampton and domestic intermodal trains from Daventry. Substantial growth is forecast both for domestic and ports intermodal.

Forecasted tonnes have been translated into freight train paths per off-peak hour and the forecast off-peak paths per hour are unconstrained. Details of the translation process can be found in Chapter 5 of the Freight Market Study.

Figure 3.7 shows the forecast freight paths for all freight commodities in 2043.

There are a number of key ports within Wales. In South West Wales Milford Haven provides a deep water port for freight and in North Wales the port of Holyhead serves Ireland. While forecast freight growth to these port locations are low, economic conditions may in the future offer greater potential to operate rail freight flows to/ from these locations.

3.3 Reference material:

More information on the Long Term Planning Process and the four established market studies can be found at:

www.networkrail.co.uk/long-term-planning-process/

Chapter 6 of the passenger market studies details the demand forecasting methodology used.

04: Conditional Outputs - Capacity and Connectivity

Highlights:

This chapter is about the outputs for meeting future demand

Capacity and connectivity are key outputs

The outputs have been analysed to see what interventions are required

These outputs are conditional on being deliverable, value for money and affordable.



Figure 4.1: Delivering capacity and connectivity

4.0 Context

As we have seen in Chapter 3, the Route Study forecasts that the railway in Wales will see continued growth over the next 10 to 30 years. This reflects the important role that rail has in shaping the competitiveness and the prosperity of the economy.

In this Route Study, the railway industry and funders have identified what needs to be done to meet this future demand. These are referred to as Conditional Outputs – they are conditional on being feasible, effective, value for money and affordable.

Conditional Outputs are descriptions about what needs to be done and there are generally two types of output:

- Outputs relating to capacity (passenger capacity and infrastructure capacity)
- Outputs relating to connectivity (frequency and/or journey time)

This Chapter describes the Conditional Outputs for the 30 year planning horizon. Chapter 5 considers those that are a priority to be accommodated in Control Period 6 (CP6) by 2023, and Chapter 6 considers those that will be required to be accommodated in the longer term to 2043. The length of this planning horizon reflects, in part, the longevity of rail infrastructure assets and investments. It also enables industry to plan the network in the context of major schemes, some of which will take many years to deliver, such as High Speed Two (HS2).

Table 4.1 Conditional outputs developed by the Welsh Route Study relating to capacity			
Ref.	Passenger market	Conditional Output	Output Options Discussed in:
C01	Cardiff commuting.	Providing sufficient capacity for passengers commuting into Cardiff during the peak hour taking account of anticipated growth to 2023 and 2043.	Sections: 4.1.2, 5.1.1, 5.1.3, 5.1.4, 6.2.2, 6.2.4.
C02	Swansea commuting.	Providing sufficient capacity for passengers commuting into Swansea during the peak hour taking account of anticipated growth to 2023 and 2043.	Sections: 4.1.3, 5.1.6, 6.2.2.
C03	Chester commuting (from Welsh Route Study corridors).	Providing sufficient capacity for passengers commuting into Chester from Welsh Route Study corridors during the peak hour taking account of anticipated growth to 2023 and 2043.	Sections: 4.1.4, 6.2.6, 6.2.10 and Northern Route Study.
C04	Shrewsbury commuting (from Welsh Route Study corridors).	Providing sufficient capacity for passengers commuting into Shrewsbury from Welsh Route Study corridors during the peak hour taking account of anticipated growth to 2023 and 2043.	Sections: 4.1.5, 6.2.5, 6.2.6 and West Midland and Chiltern Route Study (for the Birmingham corridor).
C05	Marches line all day capacity.	Providing sufficient all day capacity for Marches line passengers taking account of anticipated growth to 2023 and 2043.	Sections: 4.1.6, 5.1.7, 6.2.5, 6.2.6.
C06	Cardiff – Manchester all day capacity.	Providing sufficient all day capacity for passengers on Cardiff – Manchester services taking account of anticipated growth to 2023 and 2043.	
C07	Cardiff – Birmingham all day capacity.	Providing sufficient all day capacity for passengers on Cardiff – Birmingham services taking account of anticipated growth to 2023 and 2043.	Sections: 4.1.7 and West Midland and Chiltern Route Study.
C08	Cardiff Central station capacity.	Provide sufficient capacity to deliver forecast growth in passenger numbers using Cardiff Central station and improve station environment for all station users.	Sections: 4.1.8, 5.1.4.

4.1 Conditional Outputs relating to capacity

This Route Study sets out the interventions required to deliver sufficient capacity to accommodate growth in demand for passenger services and rail freight to 2023 and 2043. As the base for these forecasts is 2019, it already includes all committed CP5 infrastructure capacity schemes, which could solve some of the capacity issues we see today.

This Route Study has used the prospering in global stability (PGS) demand scenario for assessing future demand and then determining what Conditional Outputs are required to meet future growth in demand. [Table 4.1](#) sets out the passenger capacity Conditional Outputs.

4.1.2 Conditional Output CO1 – Cardiff commuting

Overview

This Conditional Output is about meeting the anticipated growth to 2043 for peak hour commuting flows into Cardiff. This is by far the biggest commuting market in Wales.

On average passenger demand is expected to grow by 69 per cent to 2023 and by 145 per cent to 2043 during the peak hours into Cardiff.

The busiest commuter flows into Cardiff are on the Valley Lines network. This is a dense urban network and while most journeys are of relatively short distance the number of station stops means that average journey times are slow. The average speed on most services is less than 20 mph.

The capacity provided for passenger commuting into Cardiff is expected to increase by 47 per cent by the end of CP5 with the use of longer electric or bi-mode Intercity Express Programme (IEP) trains and three-car Electric Multiple Units (EMUs) as part of the Great Western Main Line (GWML) and Valley Lines electrification respectively.



Passenger demand analysis

The committed interventions, will allow the potential of up to 49 trains to arrive into the central Cardiff area in the morning peak hour (08:00-09:00) from 2019.

For planning purposes, the number of passenger trains specified at the end of 2019 is taken as the baseline for assessing future passenger demand. The amount of capacity provided by these services is defined as the number of seats, plus a further allowance for standing passengers making short trips of up to 20 minutes.

The rolling stock to operate on the electrified local network of Valley Lines, Ebbw Vale Line and the Maesteg services is assumed to be three-car electric rolling stock with a generic capacity of 303 passengers. The long distance services from London will be operated by IEP trains, formed of either nine-car electric or five-car bi-mode sets, which can be operated as 10-car trains. The nine-car IEPs have a total of 647 seats and the five-car bi-mode IEPs have a total of 326 seats.

[Figures 4.2](#) and [4.3](#) demonstrate the average train load into Cardiff stations from key corridors during peak hours for 2023 and 2043 based on three-car electric stock being used.

The analysis shows that additional capacity will be required by 2023 for the Caerphilly, Pontypridd, Barry, Penarth and Ebbw Vale corridor and more corridors by 2043.

The Welsh Government is currently funding development work to review options to increase the service frequency on the Ebbw Vale Line from one train per hour to two trains per hour. Network Rail will work closely with the Welsh Government on the potential options for the Ebbw Vale Corridor to provide sufficient capacity for CP6 and beyond.

While the post electrification rolling stock strategy is under consideration, [Figures 4.4](#) to [4.7](#) shows the average train load into Cardiff during the peak hours if four or six-car electric stock was used.

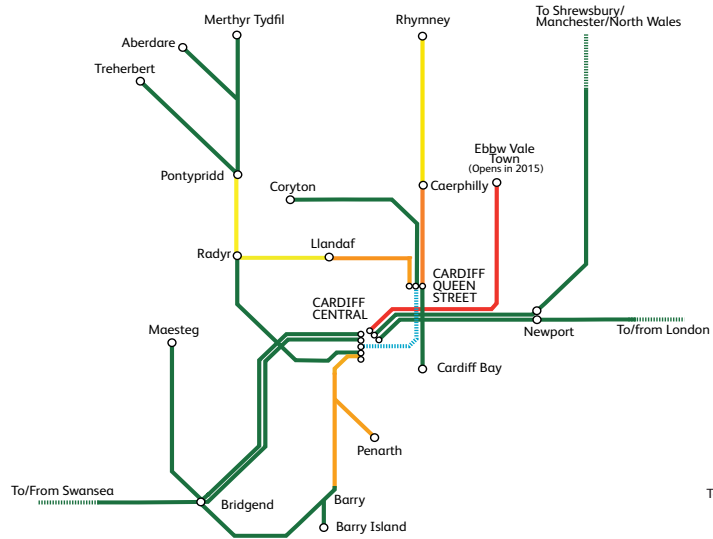

Figure 4.2: Capacity utilisation on key corridors arriving into Cardiff stations for the high peak hour in 2023 (assuming capacity of three-car electric stock on electrified local services)

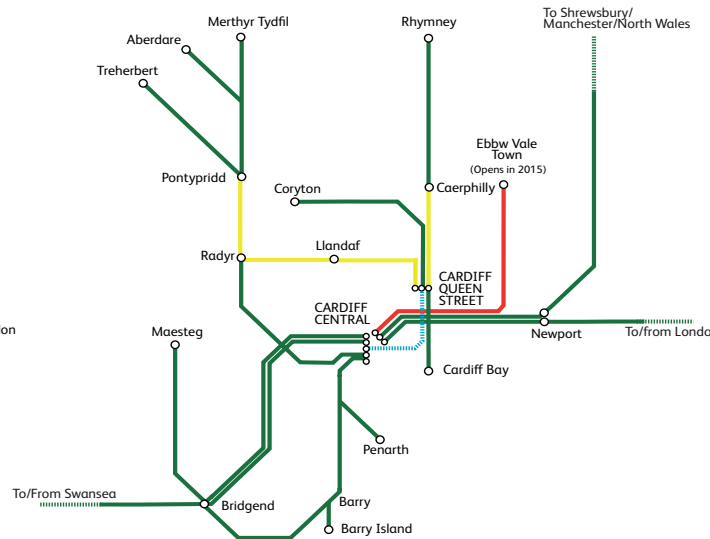

Figure 4.4: Forecasted loading on key corridors arriving into Cardiff stations for the high peak hour in 2023 (assuming capacity of four-car electric stock on electrified local services)

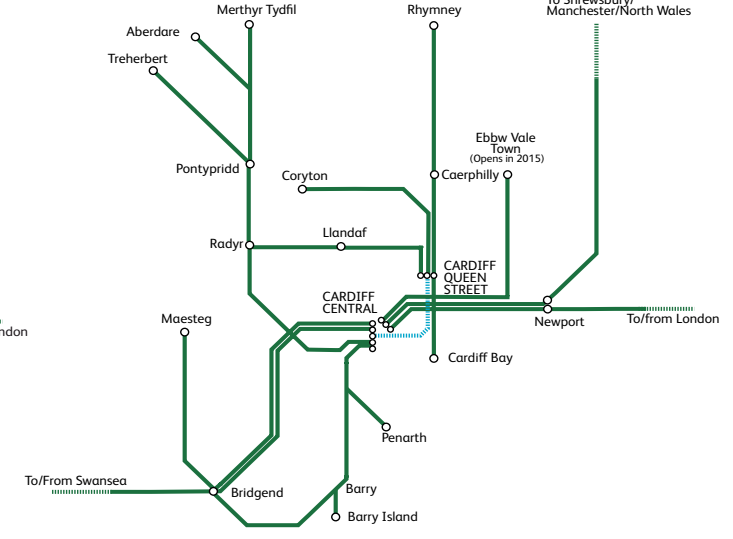

Figure 4.6: Forecasted loading on key corridors arriving into Cardiff stations for the high peak hour in 2023 (assuming capacity of six-car electric stock on electrified local services)

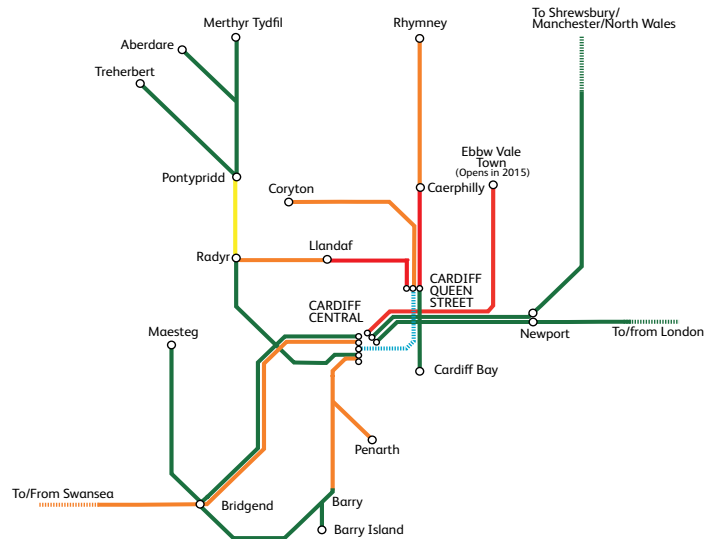

Figure 4.3: Forecasted loading on key corridors arriving into Cardiff stations for the high peak hour in 2043 (assuming capacity of three-car electric stock on electrified local services)

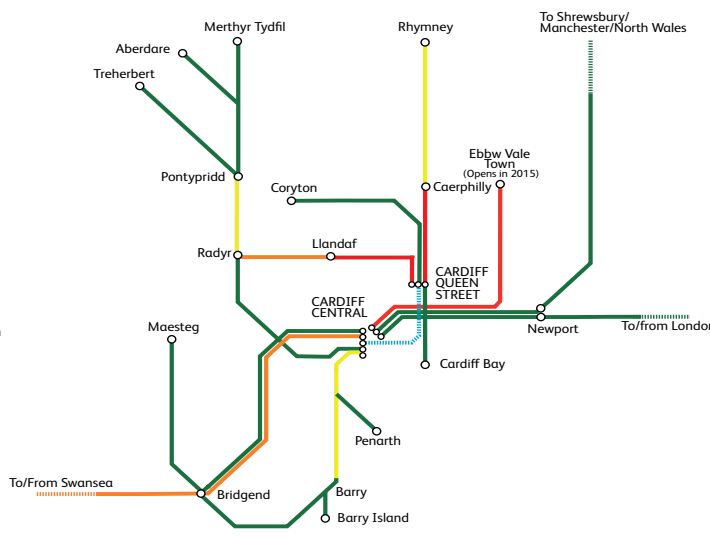

Figure 4.5: Forecasted loading on key corridors arriving into Cardiff stations for the high peak hour in 2043 (assuming capacity of four-car electric stock on electrified local services)

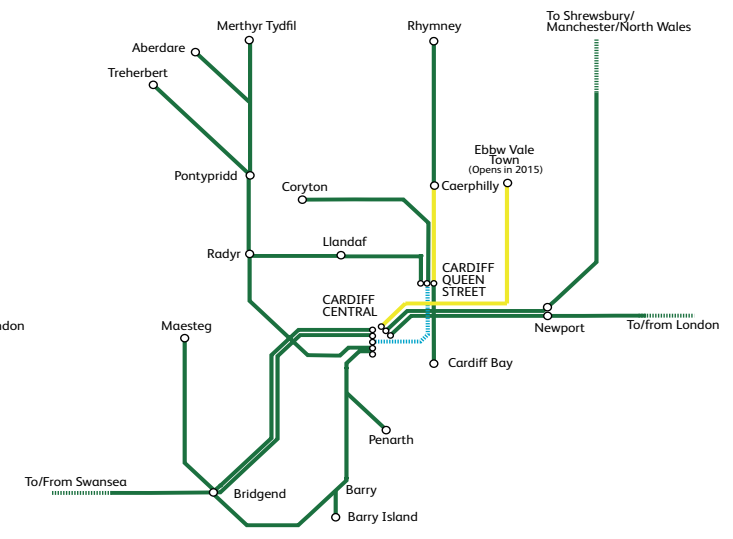

Figure 4.7: Forecasted loading on key corridors arriving into Cardiff stations for the high peak hour in 2043 (assuming capacity of six-car electric stock on electrified local services)

Capacity utilisation by corridor

- █ Seats available - up to 70% seats taken
- █ Seats busy - up to 70% - 85% seats taken

- █ Seats full (standing on some trains) - up to 85% - 100% seats taken
- █ Standing - over 100% capacity used

▤ Not shown

4.1.3 Conditional Output CO2 – Swansea commuting

Overview

This Conditional Output is about meeting the anticipated growth to 2043 for peak hour commuting flows into Swansea. Most of these journeys originate from Carmarthen to the west including all local stations and from Cardiff to the east including all local stations.

On average passenger demand is expected to grow by 30 per cent to 2023 and by 86 per cent to 2043 during peak hours into Swansea.

The capacity provided for passenger commuting into Swansea is expected to increase by 19 per cent by the end of CP5 with the use of longer electric or bi-mode IEP trains as part of the GWML electrification (see [Section 2.3](#)), and an additional morning service from the Heart of Wales Line which is operating initially on a three year trial from 2015.

Passenger demand analysis

With the committed interventions, there will be 6 trains arriving into Swansea in the morning high peak hour (08:00-09:00) from 2019.

For planning purposes, the number of passenger trains specified at the end of 2019 is taken as the baseline for assessing future passenger demand. The amount of capacity provided by these services is defined as the number of seats, plus a further allowance for standing passengers making short trips of up to 20 minutes.

The rolling stock to operate on the local service between Cardiff and Swansea is assumed to be three-car electric rolling stock with a generic capacity of 304 passengers. The long distance services from London will be operated by IEP trains, formed of either nine-car electric or five-car bi-mode sets, which can be operated as 10-car trains. The nine-car IEPs have a total of 647 seats and the five-car bi-mode IEPs have a total of 326 seats.

The average train load arriving into Swansea in the morning peak hour from all corridors is 30 per cent in 2023 and 44 per cent in 2043. The planned capacity is sufficient to accommodate demand growth for the morning peak arrival into Swansea for 2023 and 2043.

4.1.4 Conditional Output CO3 – Chester peak hour capacity (from Welsh Route Study corridors)

Overview

This Conditional Output is about meeting the anticipated growth to 2043 for peak hour flows into Chester from Welsh Route Study corridors. The most significant commuter flows into Chester from Welsh Route Study corridors, are from stations to the west along the North Wales Coast, from stations to the south including Wrexham, and from Crewe to the east. Capacity for corridors from Liverpool and Manchester will be considered in the Northern Route Study.

On average passenger demand is expected to grow by 20 per cent to 2023 and by 67 per cent to 2043 during peak hours into Chester from Welsh Route Study corridors.

Passenger demand analysis

The number of trains arriving into Chester during the morning high peak hour (08:00-09:00) from 2019 will be the same as today, with five trains arriving from the North Wales Coast, Wrexham and Crewe corridor.

The average train load arriving into Chester from Welsh Route Study Corridors in the morning high peak hour is 47 per cent in 2023 and 68 per cent in 2043. The planned capacity is sufficient to accommodate demand growth for the morning peak arrival into Chester for 2023 and 2043.



4.1.5 Conditional Output CO4 – Shrewsbury peak hour capacity (from Welsh Route Study corridors)

Overview

This Conditional Output is about meeting the anticipated growth to 2043 for peak hour flows into Shrewsbury from the Welsh Route Study corridors. Capacity for the corridor from Birmingham will be discussed in the West Midlands and Chiltern Route Study.

The most significant commuter flows into Shrewsbury from Welsh Route Study corridors are from stations to the west along the Cambrian Main Line, from stations to the north towards Wrexham, to stations to the south towards Hereford and to stations to the east towards Crewe.

On average passenger demand is expected to grow by 24 per cent to 2023 and by 82 per cent to 2043 during peak hour into Shrewsbury from Welsh Route Study corridors.

Passenger demand analysis

The number of trains arriving into Shrewsbury during the morning high peak hour (08:00-09:00) from 2019 will be the same as today, with five trains arriving from the North Wales Coast, the Marches and Crewe corridor. From May 2015, for a trial period of three years, there will be a peak morning arrival at Shrewsbury from the Cambrian main line.

The average train load arriving into Shrewsbury from Welsh Route Study Corridors in the morning peak hour is 35 per cent in 2023 and 51 per cent in 2043. The planned capacity is sufficient to accommodate demand growth for the morning peak arrival into Shrewsbury for 2023 and 2043.



4.1.6 Conditional Output CO5 & CO6 – Marches Line and Cardiff - Manchester all day capacity

Overview

This Conditional Output is about meeting the anticipated growth to 2043 for all day flows along the Marches line between Cardiff, Hereford, Shrewsbury, Crewe and Manchester. This is an important corridor as it serves a number of different markets – local, commuting, leisure and long distance.

On average passenger demand is expected to grow by 34 per cent to 2023 and by 141 per cent to 2043 for this flow.

Passenger demand analysis

The service operating on the corridor between Cardiff and Manchester via the Marches is an hourly service with 15 southbound and 16 northbound trains each day. The same service level is assumed to operate on this corridor in 2023 and 2043.

The service serves passengers for the long distance market between South Wales and Manchester and local markets between stations on the Marches. The service is also used by commuting passengers during the morning and evening peak into economic centres, such as Cardiff and Manchester as well as Hereford and Shrewsbury.

Figure 4.8: Capacity utilisation on departure for services from Cardiff to Manchester in 2023



Figures 4.8 and 4.9 show the train load on individual trains on the corridor during the day in 2023.

Additional capacity is required for some of the busy services on this corridor by 2023. The loading pattern illustrated in Figures 4.8 and 4.9 shows that extra capacity might only required for some sections on the service to meet local demand on the Marches or commuting stations to Cardiff and Manchester.

This Welsh Route Study considers interventions to provide extra capacity for the services identified in the analysis and the choices for funders are presented in Section 5.1.7.

In the longer term capacity to 2043 can be accommodated by additional services set out in the 2043 Indicative Service Specification (ITSS) in Section 4.5.

Figure 4.9: Capacity utilisation on departure for services from Manchester to Cardiff in 2023

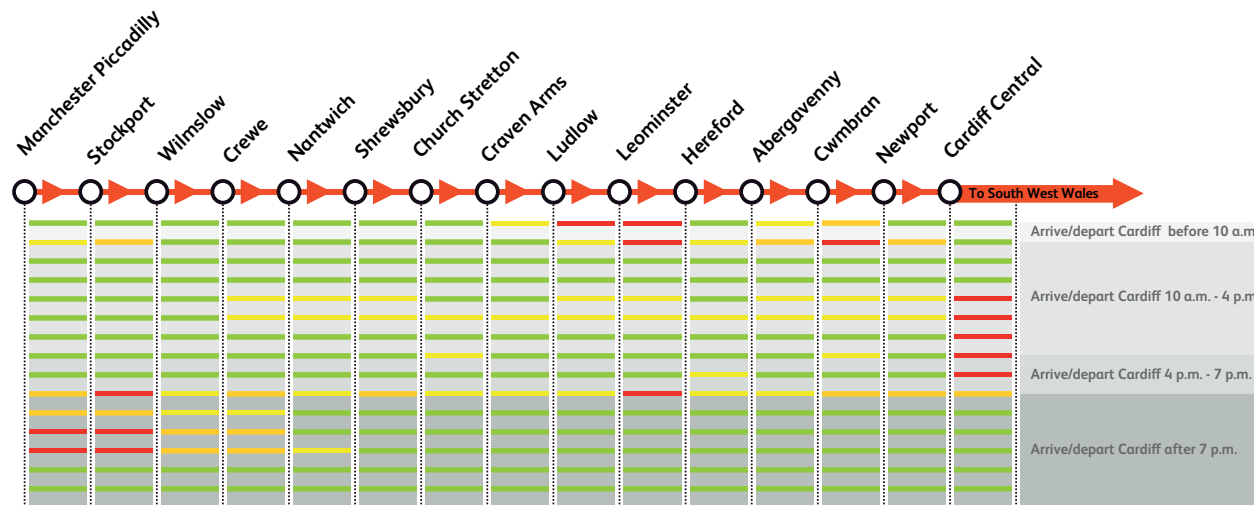

4.1.7 Conditional Output CO7 – Cardiff - Birmingham all day capacity

Overview

This Conditional Output is about meeting the anticipated growth to 2043 in the all day market between Cardiff and Birmingham.

On average passenger demand is expected to grow by 35 per cent to 2023 and by 93 per cent to 2043 for this flow.

The corridor between Cardiff and Birmingham is served by an hourly service throughout the day. The service covers the interurban market between Cardiff and Birmingham, also serving local markets along the corridor and commuting demand into Birmingham and Cardiff during the morning and evening peak.

Passenger demand analysis

With the same service level assumed for 2023, several trains in the morning and evening peak hours require extra capacity to meet demand growth for commuting on this line of route into Birmingham. However, the baseline capacity provided is sufficient to accommodate demand for commuting into Cardiff.

Interventions to provide extra capacity on the busy peak services would be required to meet demand in 2023 and this will be considered in the West Midlands and Chilterns Route Study.

Capacity utilisation key

- Seats available - up to 70% seats taken
- Seats busy - up to 70% - 85% seats taken
- Seats full - up to 85% - 100% seats taken
- Standing - over 100% capacity used

Figure 4.10: Future passenger demand forecast for journeys to and from Cardiff Central

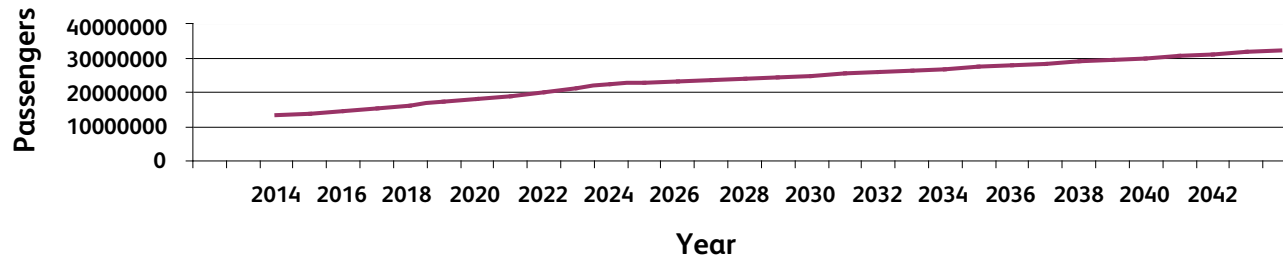

Figure 4.11: Artists impression of the redevelopment of Cardiff Central



4.1.8 Conditional Output CO8 – Cardiff Central station passenger capacity

Overview

Cardiff Central station is the largest and busiest station in Wales. Based on 2012/13 information, there are 13 million journeys starting, finishing or interchanging at the station. It serves as a key destination for long distance and inter-urban services from various locations within the country, also as an entry point to the capital city for local commuters.

Passenger demand analysis

The demand forecasts suggest the number of journeys will grow from 13 million in 2013 to 23 million by 2023 and then to 33 million by 2043. This reflects the importance of Cardiff as an economic centre and the increase in commuting and business journeys.

This means the capacity of the station needs to be improved to accommodate more passengers more often, and improve the customer experience to satisfy more passengers more often. These plans include lengthening Platform 0 so that it becomes a full length facility suitable for IEP trains – the analysis demonstrates the requirement for this as another full length platform in the London direction is required to meet demand up to 2043 (see [Section 6.2.2](#)).

Synthesis and conclusions

As railway stations are the primary interface with customers, Network Rail is developing plans for creating a station that is fit for a capital city. The plans focus on achieving three outputs:

- More capacity
- Excellent customer experience
- Spatial integration with the bus station and the city centre's facilities

These plans are in the early stages of the development process and Network Rail will develop choices to funders as part of the Initial Industry Plan (IIP) and High Level Output Specification (HLOS) processes.

4.2 Conditional Outputs for freight

Table 4.2 outlines the Conditional Outputs that have been identified for freight flows that operate across Wales, from and to the rest of the UK. These outputs primarily relate to the importance of rail to Welsh industries and businesses and the need to ensure that capacity is provided, especially for the steel and energy industries. The outputs have been established upon the growth forecasts within the Freight Market Study.

Table 4.2 Conditional Outputs developed by the Welsh Route Study for rail freight capacity				
Ref	Freight Market	Conditional Output	Conditional Output Analysis Overview	Output Options Discussed in:
C09a	Growth in freight markets identified in the Freight Market Study.	Accommodating anticipated freight demand for freight services to 2043.	Rail freight is important to the economy, and sufficient capacity requirements must be identified and accounted for over the long term. The national energy policy heavily influences the freight market within Wales. Improving the competitiveness and resilience of the railway for transporting freight is an underlying priority for these Conditional Outputs.	Section: 5.1, 6.2.
C09b	Steel traffic between Llanwern and Port Talbot (Margam).	Providing network capacity and capability for the provision of one additional freight path in each hour between Severn Tunnel Junction and Margam to take account of the growth in steel traffic between Llanwern and Port Talbot.		
C09c	Freight services on the Marches Line.	Providing network capacity and capability for the provision of one hourly off peak path between Newport and Shrewsbury to take account of freight growth and potential re-routing of freight traffic from other parts of the network.		



4.3 Conditional Outputs relating to Connectivity

4.3.1 Definition of connectivity

For the purpose of this Route Study, the definition of connectivity relates to the following aspects of the passenger timetable:

- Service frequency between locations
- Journey times
- The provision of direct journeys and effective interchange arrangements

The passenger market studies set out in more detail how Conditional Outputs for connectivity have been developed in the Long Term Planning Process (LTPP). Broadly though, they consider the role that rail can play in growing the national and regional economies and how they can deliver the following strategic goals:

- enabling economic growth
- reducing carbon and the transport sector's impact on the environment
- improving the quality of life for communities and individuals
- improving affordability and value for money.

4.3.2 Conditional Outputs from the Long Distance and Regional Urban Market Studies

Tables 4.3 and 4.4 outline Conditional Outputs relating to connectivity which are derived from the Long Distance Passenger Market Study and Regional Urban Market Study respectively. These relate to long distance services between prime economic centres within Wales and the UK.

The Long Distance Market Study set out aspirations that the industry should work towards improving connectivity between major UK centres over a 30-year planning horizon to 2043. These aspirations to improve connectivity (and hence provide improvements in generalised journey time) have been set out within the Long Distance Market Study as Conditional Outputs that could deliver a typical end to end improved average journey speed and an improved frequency of service subject to affordability considerations.

For a number of long distant flows to and from Wales, the Welsh Route Study has assessed how increased frequency of services might be accommodated on the network in the longer term as achieving end to end average journey speeds of up to 160 mph would in all likelihood require the delivery of new high speed lines. The development of new high speed lines is being led by UK Government and therefore this Route Study does not consider the implications of a potential new high speed line between South Wales and London.

4.3.3 Conditional Outputs for connectivity developed by the Welsh Route Study

These are Conditional Outputs developed by the Welsh Route Study for passenger markets to, from and within Wales which were not assessed by the Long Distance Market Study and Regional Urban Market Study.

Where a Conditional Output has not been identified it is assumed that the existing level of service (in the baseline) is maintained.

The Welsh Route Study Working Group spent much time on developing the evidence base for these Conditional Outputs and they reflect the input from the industry and funders.

The full list of Conditional Outputs developed by the Welsh Route Study is listed in Table 4.5.



Table 4.3 Conditional Outputs related to connectivity - from the Long Distance Market Study¹

Ref	Long Distance Passenger Market	Conditional Output	Conditional Output Analysis Overview	Output Options Discussed in:
CO10	Cardiff - London.	Very fast service of 3-4 trains per hour with an end to end journey speed of 160 mph.	These Conditional Outputs reflect the existing passenger markets and the need to improve connectivity.	Sections: 5.1.3, 6.2.2, 6.2.5.
CO11	Swansea - London.	Intercity 2-3 trains per hour with an end to end journey speed of 100 mph.		
CO12	Cardiff - Bristol.	Medium frequency interurban service 3-4 trains per hour with an end to end journey speed of 60 mph.		
CO13	Swansea - Bristol.	Interurban/new interurban connection of 1 to 2 trains per hour with an end to end journey speed of 80/45 mph.		
CO14	Cardiff - Birmingham.	Interurban service of 1 to 2 trains per hour with an end to end journey speed of 80 mph.	This Conditional Output reflects the existing passenger markets and the need to improve connectivity. There are commercial aspirations to improve journey times between Cardiff and Birmingham New Street. Future accommodation of this Conditional Output will be assessed by this Route Study along with the neighbouring Western and West Midlands and Chiltern Route Studies.	Sections: 5.1.3, 6.2.2, 6.2.5.
CO15	Cardiff - Leicester.	Interurban service of 1 to 2 trains per hour with an end to end journey speed of 80 mph.	These Conditional Outputs reflect both the existing passenger markets and consider future direct services to a range of potential new destinations such as Leicester, Sheffield and Leeds.	Sections: 5.1.3, 6.2.2, 6.2.5.
CO16	Cardiff - Sheffield.	Interurban service of 1 to 2 trains per hour with an end to end journey speed of 80 mph.		
CO17	Cardiff - Manchester.	Intercity service of 2 to 3 trains per hour with an end to end journey speed of 100 mph.		
CO18	Cardiff - Leeds.	Interurban service of 1 to 2 trains per hour with an end to end journey speed of 80 mph.		
CO19	Shrewsbury - London.	Interurban service of 1 to 2 trains per hour with an end to end journey speed of 80 mph.	The Conditional Outputs reflect the need to improve connectivity between regions which currently have no constant direct services. There are some peak services between Wolverhampton and London Euston which will be extended to/from Shrewsbury from December 2014	Sections: 6.2.5, 6.2.6.
CO20	Shrewsbury - Liverpool.	Interurban/new interurban connection of 1 to 2 trains per hour with an end to end journey speed of 80/45 mph.		
CO21	North Wales Coast - London.	Interurban service of 1 to 2 trains per hour with an end to end journey speed of 80 mph.	These Conditional Outputs reflect both the existing passenger markets and the growing demand for direct services to Liverpool. This is considered important as the economies of North Wales and Merseyside are closely linked. Hence the UK Government's recent provision of funding to improve the Halton Chord to improve rail links between these regions.	Sections: 5.1.8, 5.1.9, 6.2.10.
CO22	North Wales Coast - Manchester.	Interurban service of 1 to 2 trains per hour with an end to end journey speed of 80 mph.		
CO23	North Wales Coast - Liverpool.	Interurban service of 1 to 2 trains per hour with an end to end journey speed of 80 mph.		
CO24	North Wales Coast - Chester.	Medium frequency interurban service 3-4 trains per hour with an end to end journey speed of 60 mph.		
CO25	Wrexham - London.	Intercity service of 2 to 3 trains per hour with an end to end journey speed of 100 mph.	These Conditional Outputs reflect the existing passenger markets and the need to improve connectivity.	Sections: 5.1.11, 6.2.6.
CO26	Wrexham - Shrewsbury.	Medium frequency interurban service 3-4 trains per hour with an end to end journey speed of 60 mph.		
CO27	Wrexham - Birmingham.	Interurban/new interurban connection of 1 to 2 trains per hour with an end to end journey speed of 80/45 mph.		

The above Conditional Output definitions should be taken as a guide for the LTPP and should be taken to mean "as fast and frequent as operationally feasible given value for money and affordability".

Table 4.4 Conditional Outputs related to connectivity - from the Regional Urban Market Study

Ref	Regional Urban Passenger Market	Conditional Output	Conditional Output Analysis	Output Options Discussed in:
CO28	Wrexham - Liverpool.	Improved generalised journey time through either increased service frequency and/or improved journey times.	This Conditional Output reflects the need to improve connectivity between the cities, as currently no direct service exists. Compatibility of trains (Diesel and 3rd Rail Powered) is currently a barrier to improved connectivity but future advances in technology might offer a potential solution. The close economic ties between Wrexham and the Wirral and Merseyside make improvements in connectivity particularly important.	Sections 5.1.11, 6.2.6 and Northern Route Study.
CO29	Newport/Severn Tunnel Junction – Bristol/Bath.	Improved generalised journey time through either increased service frequency to three services per hour and/or improved journey times.	These Conditional Outputs reflect the existing passenger markets and the need to improve connectivity between the areas, which is important for commuters and businesses.	Sections 6.2.2 and Western Route Study.

Table 4.5 Conditional Outputs related to connectivity developed by the Welsh Route Study

Ref	Passenger Market - Connectivity	Conditional Output	Conditional Output Analysis Overview	Output Options Discussed in:
CO30	South Wales Main Line.	Improved generalised journey times between Bristol and Swansea (service frequency).	This output is about improving connectivity between these locations by utilising all of the available infrastructure to address future capacity constraints.	Sections 5.1.3, 6.2.2.
CO31	Cardiff - Swansea local Stations.	Improved service frequency to local stations between Cardiff Central and Swansea.	This output focuses on meeting the market for commuting and leisure travel from surrounding local stations. These local stations are currently under used and could help to meet future demand due to their large catchment areas, which would reduce overall journey times for the passengers using these stations.	Sections 6.2.2.
CO32	Valley Lines.	Improved generalised journey times on the Valley Lines (service frequency and journey time improvements).	Electrification of the Valley Lines will have a positive impact on connectivity and journey times, which are currently relatively slow. This is expected to widen the labour market catchment and improve the area's economic strength. As a wider part of the electrification project, further infrastructure improvement options will be assessed. Journey time savings are a priority due to the 3.5 minute sequentially flighted nature of trains into Cardiff Queen Street and Central. Alternatively, theoretical journey time improvements could be used to create Performance buffers within the timetable to absorb additional station stops. Some single line sections are of a longer term strategic and fleet capacity constraint which could be addressed by a doubling of the lines.	Sections 5.1.2, 6.2.4.
CO33	Ebbw Vale - Newport.	Improved connectivity between Ebbw Vale and Newport (service frequency).	The 2008 Ebbw Vale line reopening has been a considerable success, helping to regenerate the area. There is a strong growth in demand requiring further capacity upgrades. Welsh Government is funding a scheme to improve frequencies on the line to provide up to three trains per hour, and the anticipated date for completion of this scheme is 2017. (Note that this scheme is not included in the baseline analysis for this study) The scheme includes passive provision for re-opening the Abertillery line and a new station at Crumlin. Specification of potential additional services will be important to meet future demand.	Section 6.2.2.
CO34	Lydney/Chepstow - Bristol.	Improved commuter connectivity between Lydney/Chepstow and Bristol (service frequency).	This output is focused on the role of commuter rail in providing access to employment, education and leisure around these areas. The market is currently constrained by uncompetitive generalised journey times compared to car, resulting from the need to change trains at Severn Tunnel Junction and frequency of service. The 2043 ITSS proposes service frequency enhancements between Severn Tunnel Junction and Gloucester, and on the South Wales Main Line which would provide for improved generalised journey time between these locations.	Section 6.2.2.
CO35	Cardiff - Birmingham and Cardiff - Gloucester flows.	Improved generalised journey times along the route between Severn Tunnel Junction and Gloucester (service frequency and journey time improvements).	This output is about improving journey times for the local markets between Cardiff and Gloucester via the Lydney route. There is close synergy between this Conditional Output and Conditional Output CO14.	Section 6.2.2,

Table 4.5 Conditional Outputs related to connectivity developed by the Welsh Route Study

Ref	Passenger Market - Connectivity	Conditional Output	Conditional Output Analysis Overview	Output Options Discussed in:
CO36	North-South Wales.	Improved generalised journey time between North and South Wales (Bangor and Holyhead to Cardiff) through increased passenger frequency and/or improvement in journey times.	Connectivity between North and South Wales is important to the economy due to the economic and social links between these two areas. Welsh Government is currently funding enhancement works between Chester and Wrexham to improve journey times and capacity on the route.	Sections 5.1.11, 6.2.2, 6.2.5, 6.2.6, 6.2.10.
CO37	South West Wales.	Improved generalised journey time through increase passenger service frequency from Fishguard Harbour and Milford Haven to Swansea and improvement in journey times from South West Wales to Swansea.	Connectivity between West Wales and Cardiff, London and the national rail network is important for business and tourism. Redoubling the South Wales Main Line between Gowerton and Loughor has freed up infrastructure capacity for more services from West Wales into Swansea. And electrification will enable Swansea to become a new hub, improving journey times and frequencies. Effective planning around the introduction of IEP trains will be important to achieve the Output.	Sections 5.1.5, 6.2.3.
CO38	Heart of Wales line commuting to Swansea & Shrewsbury.	Improved morning peak arrival time for Heart of Wales line service to Swansea and Shrewsbury.	The Heart of Wales and Cambrian Main Lines are largely rural railways that serve a number of commuter markets. These Conditional Outputs are about improving the ability to commute into economic centres at both ends of these routes. Welsh Government is funding additional peak time journeys from 2015 for three years which will then be reviewed.	Sections 5.1.6, 5.1.13, 6.2.7, 6.2.8.
CO39	Cambrian line commuting to Aberystwyth & Shrewsbury.	Improved generalised journey time through either increased service frequency from the Cambrian Line to Shrewsbury and beyond and/or improved journey times.		
CO40	Deeside.	Improved rail accessibility to employment in Deeside by improving connectivity and service frequency.	The Deeside area is important to the manufacturing industry of Wales, with better connectivity to the Enterprise Zone being viewed as possible for journeys from the North of Wales, Chester and Wrexham to Bidston line.	Sections 5.1.10, 5.1.12, 6.2.9, 6.2.10.

4.4 Additional Conditional Outputs

This section is about the more generic Conditional Outputs that are set out in the established market studies and how they specifically relate to this Welsh Route Study. These are listed in [Table 4.6](#).

4.4.1 Conditional Output CO41 - Airport Connectivity

This Conditional Output relates to improving rail connectivity to the major airports that serve the different parts of Wales (Cardiff, Bristol, London Heathrow, London Gatwick, Manchester International, and Liverpool John Lennon)

4.4.1.1 Cardiff Airport

Cardiff Airport provides flights to mainly European destinations with some longer haul flights to holiday destinations. The airport has plans to increase the number of flights. While it is not directly connected to the railway it is well served by a frequent rail linked bus shuttle service from Cardiff city centre and also by a connecting shuttle bus from nearby Rhoose Station.

The baseline assumes the committed service frequency increases along the Vale of Glamorgan line which will provide a 30 minute service to nearby Rhoose Station. Conditional Output CO32 to achieve generalised journey time improvements on Valley Lines will improve connectivity to the airport.

There are choices for funders about whether Cardiff Airport is best served by connectivity from Cardiff city centre, by connectivity from Rhoose station, or both. Similarly, there are longer term options for Cardiff Airport from the Cardiff Capital Region Metro aspirations which could see trams operating to the airport terminal.

4.4.1.2 Bristol Airport

Bristol Airport provides flights to European and African destinations and is well served by shuttle bus links from Bristol Temple Meads station. Bristol Airport does offer a range of domestic and international flight destinations that are not served by Cardiff Airport and as such this is a relatively convenient local airport for the Cardiff and South Wales region. There is a Conditional Output relative to the Cardiff – Bristol rail passenger market which sets out the requirement to improve connectivity between Cardiff and Bristol (frequency and journey time), which does provide for overall improved generalised journey time and connectivity to Bristol

Airport from Cardiff and South Wales.

4.4.1.3 London Heathrow Airport

London Heathrow Airport is one of the busiest airports in the world offering flights to worldwide destinations and is situated on a spur off the GWML. The airport is currently well served by rail services from London Paddington.

In CP5, Network Rail is developing plans for a new Western Access rail line from the GWML east of Slough to Heathrow, with delivery planned for early CP6. This will provide for more frequent and faster journey opportunities from South Wales by a combination of the Conditional Outputs set for South Wales to London passenger market which will provide for the ability to change into regular Heathrow Airport services at Reading.

4.4.1.4 London Gatwick Airport

London Gatwick Airport is the UK's second busiest airport offering flights to worldwide destinations. The airport has a dedicated rail station on the main line between London and Brighton and is also served by regular services from Reading on the Great Western Main Line.

A combination of the Conditional Outputs set for services between South Wales and London (calling at Reading) and Conditional Outputs set for services between Reading and Gatwick Airport provide for overall improved generalised journey time and connectivity to Gatwick Airport from Cardiff and South Wales.

4.4.1.5 Manchester International Airport

Manchester International Airport is one of the busiest airports within Europe offering scheduled and charter flights to worldwide destinations. The airport has a dedicated rail station with scheduled rail services from many locations in the north of England including a number of direct services to and from North Wales. Conditional Output CO22 sets out the requirement for passenger connectivity between North Wales and Manchester and this potentially offers the opportunity for extending services to and from Manchester Airport subject to trade-offs with other service specification opportunities in the North of England. Additionally travel opportunities exist by change of train at Crewe.

Table 4.6 Additional Conditional Outputs

Ref.	Passenger market	Conditional Output	Output Option Discussed in:
CO41	Rail-airports.	Airport connectivity.	Section 4.4.1.
CO42	HS2.	Providing connectivity to the planned HS2 network.	Section 4.4.2.
CO43	Major ports.	Providing connectivity to major ports within Wales.	Section 4.4.3.
CO44	Leisure.	Improving capacity and connectivity for weekend and weekday leisure markets.	Section 4.4.4.
CO45	Higher education and other social infrastructure.	Access to higher education establishments and other social infrastructure.	Section 4.4.5.
CO46	Passenger satisfaction.	Improved passenger satisfaction.	Section 4.4.6.
CO47	Integrated transport.	Improved local access to rail to cater for demand.	Section 4.4.7.

4.4.1.6 Liverpool John Lennon Airport

Liverpool John Lennon Airport is situated close to Liverpool Parkway station on the main line between Runcorn and Liverpool Lime Street. It provides flights to mainly European destinations. Conditional Output CO23 sets out the requirements for improving connectivity between North Wales and Liverpool and CO28 sets out the requirement for improving connectivity between Wrexham and Liverpool (both which currently have no direct rail services) and this offers the opportunity to provide this connection via Liverpool Parkway station to enable improved connectivity to Liverpool John Lennon Airport.

4.4.1.7 Birmingham International Airport

Birmingham International Airport is situated alongside the main Line between Birmingham New Street and London Euston. It provides flights to Europe, Africa and North and Central American destinations.

There is currently a two-hourly service between North Wales / Mid Wales and Birmingham International providing good connectivity with the airport from North Wales, Wrexham, Shrewsbury and Mid Wales and Conditional Output CO27 sets out the requirement for improving connectivity from Wrexham to Birmingham which in turn offers opportunities for further improving connectivity with the airport.

4.4.2 Conditional Output CO42 - HS2 Connectivity

This Conditional Output relates to the opportunity provided by HS2 to improve journey time and connectivity by either extension of HS2 services onto the Welsh Route network, or by connections into HS2 at Birmingham, once Phase 1 is completed in 2026.

4.4.3 Conditional Output CO43 – Connectivity to Major Ports

This Conditional Output relates to the opportunity to improve access to major ports.

Within Wales, the ports at Fishguard, Pembroke Dock and Holyhead offer passenger and roll on – roll off vehicular services to Southern Ireland.

The range of Conditional Outputs set within the Welsh Route Study (CO21-24 and CO37) provide opportunities to improve connectivity

to these ports by improving service frequencies and/or generalised journey time to/from other main UK and Wales regional and economic centres.

The Freight Market Study has identified the future demand for freight commodities within the UK and this has been translated into the requirement for freight capacity on the network in Wales. In West Wales, Milford Haven is one of the deepest ports for freight shipping in the UK and there is potential to increase freight services in the future.

Connectivity to ports for passenger markets is important for flows between Ireland and Great Britain and this is amplified during times when flights are disrupted due to weather, volcanic ash or other events. These are generally low frequency events and the industry puts in place short term actions to move capacity around to fulfil demand requirements.

4.4.4 Conditional Output CO44 – Improving capacity and connectivity for the leisure markets

The busiest times for travel to and from urban retail and tourism centres are often at weekends and during weekday evenings. This is in contrast to the typical weekday peak for commuting and business travel, when the highest current levels of train service frequency and capacity are provided. The increase in leisure use of rail in recent years is improving the financial case of rail lines which previously served predominantly commuter flows, as it allows better utilisation of resources that are required to deliver the peak timetable.

The implication of seasonal peaks on demand is an issue very relevant to the Wales Route Study. Rail passenger demand significantly fluctuates in some corridors in West, Mid and North Wales during the year with seasonal demand predominantly driven by leisure and tourism in the summer months. On the North Wales Coast, rail passenger demand is also driven by business passengers and commuters. Figure 4.12 presents the percentage of journeys made to and from these locations in 2013. It shows the rise in rail passenger demand from May, peaking in the summer months and generally declining in the winter.



The busiest time for leisure travel is often at weekends, which coincides with significant railway engineering activities timed to minimise disruption to commuting and business passengers. The evolving leisure market is important to the local economy and therefore the Conditional Output is to provide sufficient capacity to avoid suppression of demand and to reduce potential on-train crowding. This involves the consideration of the potential trade-offs resulting from alternative engineering regimes, including an assessment of the value for money and affordability implications.

The Wales Route Modernisation Plan sets out plans to modernise the rail network in Wales. A consequence of this work will be the ability to centralise control of the network and make it more cost efficient to open routes for longer hours (where they are not currently so), offering better opportunity to run services during these hours.

Figure 4.12: Journeys to/from key Welsh tourism corridors in 2013

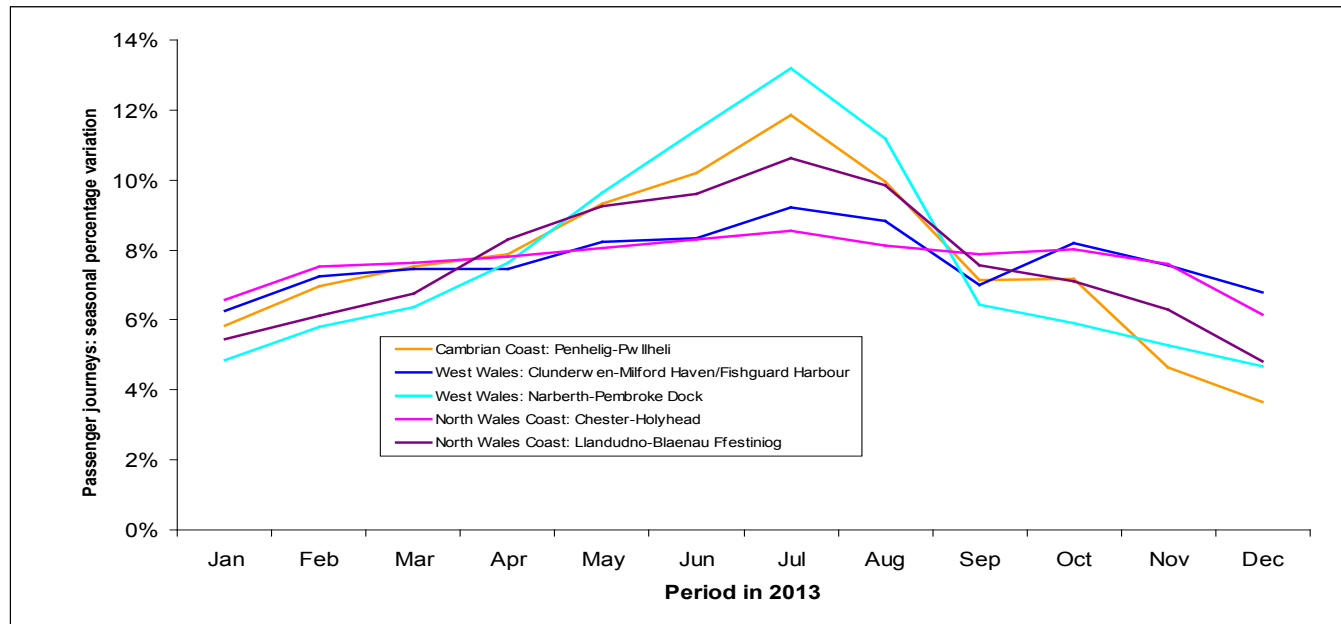

4.4.5 Conditional Output CO45 – Access to higher educational establishments and other social infrastructure

Improving accessibility to higher education establishments and social infrastructure is important to achieve the strategic goal of improving the quality of life for communities and individuals. In some routes the demand for travel to these markets is high.

This Route Study considers places where a market has a significant impact on demand and affects the level of service provision that is required to meet that demand. Demand scenarios in the Long Distance Market Study show that an increase in demand in long distance travel is predicted in some circumstances and more students are willing to travel for longer distances to gain access to education.

Rail is increasingly becoming the mode of choice for students. There are a number of services in Wales where the timetable and the capacity allocated is geared around school and college times, such as the Cambrian Coast service. There are choices for funders, train operating companies and franchise authorities about connectivity with schools and colleges and capacity allocation. These are local decisions and are best dealt with on a case by case basis. The analysis within this Route Study will help inform decisions about the capacity trade-offs between meeting local demand or meeting longer distance demand. This Route Study identifies Conditional Outputs to improve connectivity to many of these locations – either by enhanced service frequencies or journey time improvements.

4.4.6 Conditional Output CO46 – Improved passenger satisfaction

Passenger travel experiences are important and directly affect demand for rail. This Conditional Output is to seek improvements to station environments, the quality, capacity and consistency of rolling stock, the availability of information to passengers and, where appropriate, train punctuality. Rolling stock needs to meet the requirements and expectations of passengers and to enable an efficient provision of rail services.

A number of the major interventions planned within Wales during CP5 such as electrification of parts of the network will have a significant impact on the rail offering to the passenger.

Additionally, during CP5 funding has been made available to improve station environments and to improve accessibility to stations for all users and Network Rail has worked with Welsh Government and operators to identify a programme of priority improvements. It is anticipated that this programme of work will continue into CP6 should funding be made available.

4.4.7 Conditional Output CO47 – Improved local access to rail network to cater for demand.

A key theme of a number of the local and regional transport strategies within Wales and the Border counties is of improving the integrated transport offering. These themes explore the opportunities to develop improved interchange between rail and other transport modes and also opportunities afforded by new technology to improve ticketing and travel choices.



4.5 Indicative Train Service Specification for 2043

The Conditional Outputs described in this chapter have been translated into an Indicative Train Service Specification (ITSS) for 2043. The 2043 ITSS for Wales can be seen in [Figure 4.13](#). The Valley Lines Network is shown separately in [Figure 4.14](#) and this represents an indicative peak hour. Each solid line represents one passenger train per hour (TPH), and the colours represent the suggested calling pattern detailed in the key. A dotted or dashed line represents less than one train per hour, as per the key.

The ITSS sets out the vision of the railway industry and funders about the optimum way of meeting these outputs, focusing on making best use of the existing network capability ahead of building new infrastructure.

The ITSS also provides an opportunity to consider:

- When an intervention might be best timed to coincide with major network renewals such as resignalling
- How a particular Conditional Output might help deliver another conditional output (e.g., a connectivity Conditional Output might help deliver increased capacity on parts of the network)
- What new service opportunities might exist where a range of Conditional Outputs can be linked together such as the Conditional Output for Liverpool to Shrewsbury (CO19) being linked to the Conditional Output for North–South Wales (CO35) that provides the opportunity to potentially provide a service between Cardiff and Liverpool that helps deliver a number of Conditional Outputs.

Figure 4.13: The Indicative Train Service Specification (ITSS) for 2043 - Wales Route (excluding the Valley Lines)

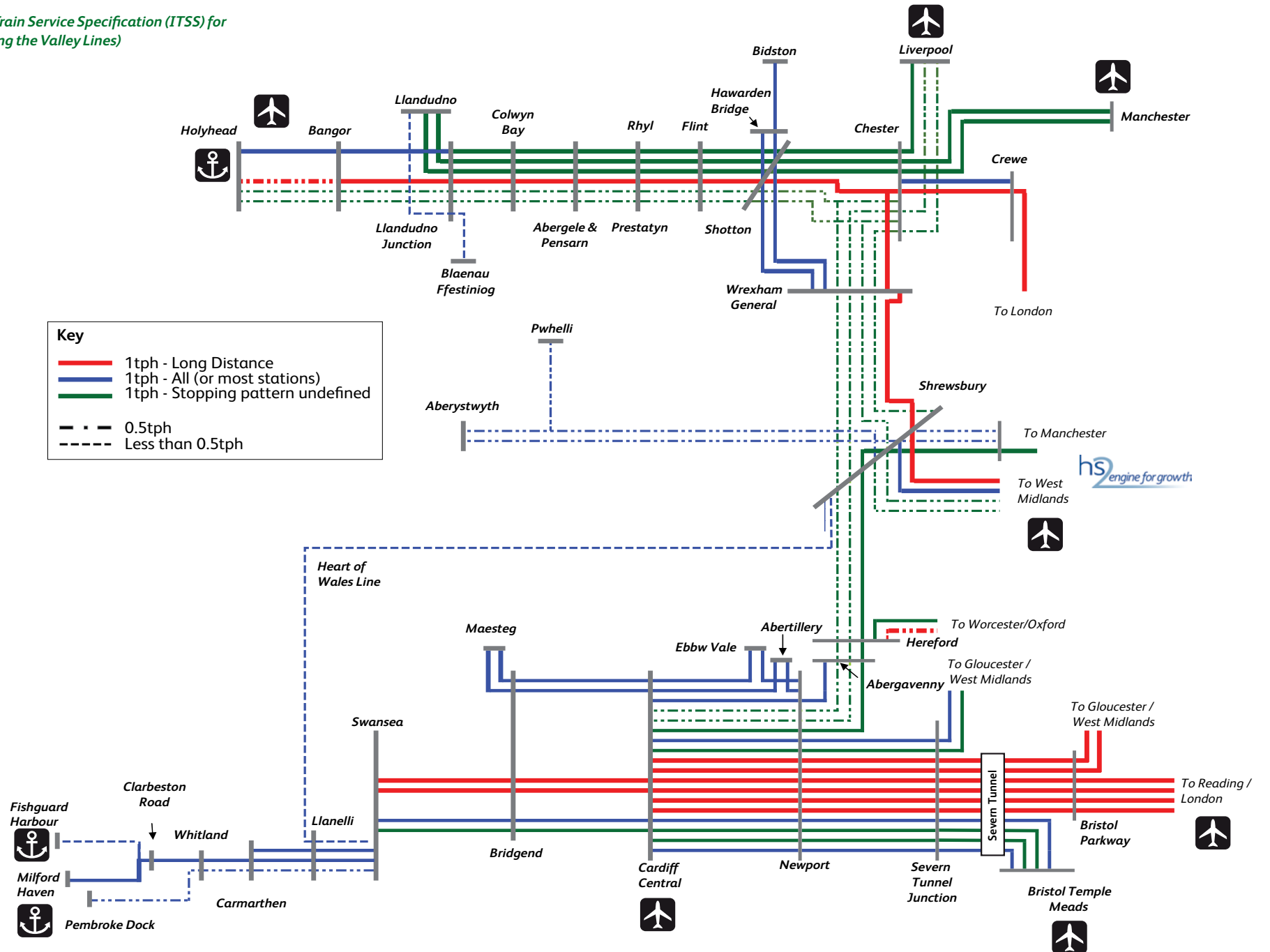
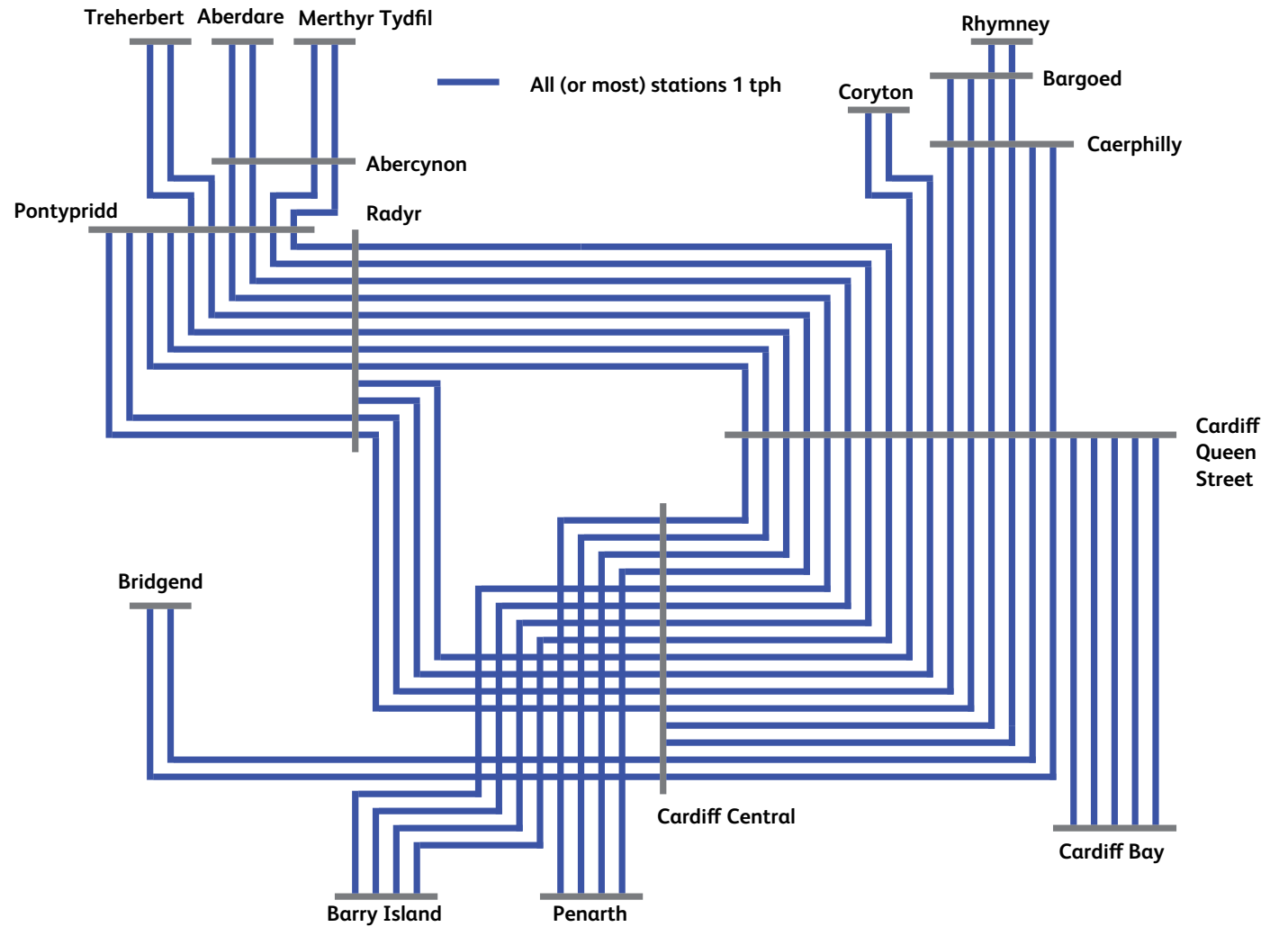

Figure 4.14: The Indicative Train Service Specification (ITSS) for 2043 - Valley Lines



05: Choices for Funders to 2024

Highlights:

The railway will need further investment so that it can meet the growth in demand between 2019 and 2024.

There are choices for funders to meet this demand and to provide better connectivity.

This chapter sets out these choices for investment across Wales and the Border counties.

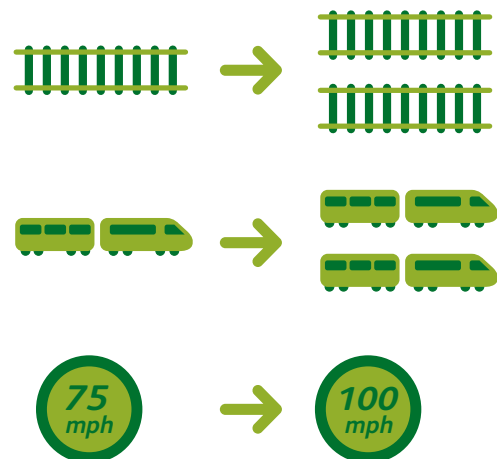

Figure 5.1: Choices for funders for CP6

5.0 Context

The choices for funders in Control Period 6 (CP6) have been developed by this Route Study using the agreed prioritisation criteria for the Long Term Planning Process (LTPP). All of the CP6 investment choices identified therefore meet one or more of the following criteria in order to deliver the Conditional Outputs:

- Investments which are required to provide sufficient capacity for the forecast level of passenger and freight demand at the end of CP6, where this investment is also consistent with the longer-term strategy for the route
- Opportunities where Conditional Outputs (or some part of the capital works necessary to deliver Conditional Outputs over a longer period of time) can be delivered most efficiently and provide the lowest whole life cost option for delivery during CP6, for example in conjunction with the planned renewal of life-expired assets
- Investments which reduce rail industry costs
- Other investments which reflect funders' priorities
- Investing in better connectivity to High Speed Two (HS2).

To meet these drivers of change, CP6 choices for funders have been investigated as part of the Welsh Route Study. These are set out in Table 5.1.

Table 5.1 Options for delivering Conditional Outputs during CP6

Option.	CP6 Choices	Conditional Outputs delivered
1	Delivery of passenger capacity on the Valley Lines.	CO1 Cardiff peak capacity.
2	Further phased programme of network enhancements to the Valley Lines.	CO32 Valley Lines journey time improvement.
3	Upgrade of Relief Lines line speed between Severn Tunnel Junction and Cardiff Central.	CO1 Cardiff peak capacity. CO10 Cardiff - London connectivity. CO11 Swansea - London connectivity. CO12 Cardiff - Bristol connectivity. CO13 Swansea - Bristol connectivity. CO14 Cardiff - Birmingham connectivity. CO15 Cardiff - Leicester connectivity. CO16 Cardiff - Sheffield connectivity. CO17 Cardiff - Manchester connectivity. CO18 Cardiff - Leeds connectivity. CO30 South Wales Main Line Journey Time Improvement.
4	Cardiff Central Station enhancement.	CO1 Cardiff peak capacity. CO8 Cardiff Central station capacity.
5	Continued programme of level crossing closures in South West Wales.	CO37 South West Wales connectivity.
6	Continuation of recently announced additional services on Heart of Wales Line.	CO2 Swansea commuting. CO4 Shrewsbury commuting. CO38 Peak arrivals at Swansea and Shrewsbury from Heart of Wales line stations.
7	Selected train lengthening on Marches Line services.	CO5 Marches Line all day capacity. CO6 Cardiff – Manchester all day capacity.
8	Modernisation of the North Wales Coast Main Line.	CO21 North Wales Coast connectivity to London. CO22 North Wales Coast connectivity to Manchester. CO23 North Wales Coast connectivity to Liverpool. CO24 North Wales Coast connectivity to Chester.
9	Improved linespeeds along North Wales Coast Main Line.	CO21 North Wales Coast connectivity to London. CO22 North Wales Coast connectivity to Manchester. CO23 North Wales Coast connectivity to Liverpool. CO24 North Wales Coast connectivity to Chester.
10	Shotton Station Interchange.	CO40 Connectivity to Deeside.
11	Network capacity enhancement between Wrexham General and Chester.	CO25 Wrexham – London connectivity. CO28 Wrexham – Liverpool connectivity. CO36 North - South connectivity.
12	Improved linespeeds between Wrexham and Bidston.	CO40 Connectivity to Deeside.
13	Continuation of recently announced additional services on Cambrian Main Line.	CO4 Shrewsbury peak hour capacity (from Welsh Route Study corridors). CO39 Cambrian line commuting to Aberystwyth & Shrewsbury.

5.1 Choices for funders in CP6

5.1.1 Option 1: Delivery of passenger capacity on the Valley Lines

As seen in [Chapter 3](#), the railway will see strong and continued growth for commuting and other travel into Cardiff. The Valley Lines services will carry much of this additional traffic as it provides a turn up and go high density service within the inner urban core.

[Section 4.1.2](#) sets out the analysis for future growth in demand for commuting into Cardiff including the Valley Lines. While train lengthening could meet the forecast growth in demand on the Valley Lines up to 2043, there are other opportunities to further improve connectivity and also to look at freeing-up spare capacity for the future.

Electrification of the Valley Lines network presents options and choices for the type of electric rolling stock that will be used on this part of the network. At this time the options for such rolling stock have not yet been determined. The final choice of rolling stock will potentially drive other infrastructure changes such as platform lengthening.

As part of the development of the project to electrify the Valley Lines network, options have been assessed for extension of platforms to enable operation of longer electric passenger rolling stock. Details are provided in [Table 5.2](#). The assumptions used in this analysis assess the requirements for up to six-car 23 meter length electric multiple unit (EMU) rolling stock on most routes.

Conditional Output CO1, Cardiff peak capacity (see [Section 4.1.2](#)) identified significant additional demand for services between Ebbw Vale and Cardiff in CP6. Welsh Government is currently funding development of a scheme to enable additional services to operate on the route to Ebbw Vale which will deliver the capacity required during CP6. This scheme, which would initially see a doubling in frequency of passenger service from one train per hour to two trains per hour is currently planned to be implemented during CP5. The plans also include provision for future additional service frequency and this is reviewed further in [Section 6.2.2](#) which considers how connectivity improvements may be delivered in the longer term between Ebbw Vale/Abertillery and Newport/Cardiff.



Table 5.2 Assessment of Option A: Valley Lines Platform Extensions

Summary of intervention:

Although decisions on what electric passenger rolling stock will operate on the Valley Lines have yet to be made, any chosen option will be three-car or four-car derivatives, capable of operation in multiple formation. Existing passenger diesel rolling stock is generally of shorter formation with many platforms across this part of the network only suitable for up to four-car length.

Output assessment:

This option has identified 63 Valley Lines stations that will require platforms to be extended. The assessment has been undertaken on the basis of providing a platform length suitable for six-car electric trains with 23 metre vehicle length for all routes with the exception of the Coryton and Cardiff Bay lines where other constraints exist and where platform length suitable for four-car electric trains with 23 metre vehicle length has been assessed.

Indicative cost:

£15 - 35 million.

Affordability assessment

This information has been developed as part of the Valley lines electrification project as a costed option for consideration by the funder, Welsh Government. It will therefore be part of the overall Welsh Government business case for Valley Lines Electrification.

5.1.2 Option 2: Further phased programme of network enhancements to the Valley Lines

Following delivery of network enhancements as part of the Cardiff Area Signalling Renewal (CASR) during CP4 and CP5, this section considers the options for further enhancing the Valley Lines network to deliver further growth and improve connectivity in the medium term by assessing options to enable improvements in operating and timetable flexibility.

Digital Railway

The Digital Railway could play a part in addressing this multi-faceted challenge, particularly as it could provide additional capacity without the need for additional civil engineering interventions. These interventions would be challenging from a feasibility and affordability perspective in the city centre as the layout and immediate environment is physically constrained by other buildings.

Cardiff Capital City Region Metro

The Welsh Government has plans to work with the business sector and the rail industry to develop a multi-modal integrated transport system for the Cardiff Capital City Region. This is branded as Metro (see Figure 5.2). It is particularly welcome as a multi-modal approach should provide options for considering the most convenient and efficient solutions for meeting the different travel markets.

The Metro approach investigates rail, light rail and tram options which would potentially free up scarce capacity. By converting some short distance routes to a mixture of on-rail and on-street running, capacity would be released to run more long distance services on the Valley Lines network.

There are a number of ideas in development to consider the potential of the Metro and the Welsh Government is consolidating this into an arms-length subsidiary company. The railway industry has an important part to play in helping the Welsh Government to shape the Metro concept to realise the full value of rail as part of a multi-modal integrated transport system. This Route Study concludes that further work should be undertaken to fully consider how the railway can play its full part in the Metro multi-modal

concept. The Metro is an ambitious programme and the railway industry is equally ambitious to demonstrate how rail can remain at the forefront of enabling economic growth and regeneration around Cardiff.

This Study presents a Choice for Funders in CP6 of further development to realise the potential of rail as part of the Metro system.

Single line sections on the Valley Lines network

Single line sections remain on some parts on the Valley Lines network and, while this does not currently constrain committed plans to meet growth in future peak capacity, it nevertheless restricts the ability to optimise the timetable and fully exploit the capability of electric rolling stock. This is particularly relevant in the context of the Metro which may seek to further improve connectivity on these lines.

To the north of Cardiff there are single line sections on the routes north of Pontypridd, between Heath Junction and Coryton and, also, between Bargoed and Rhymney. There are out-based stabling facilities at Treherbert and at Rhymney and the single line sections on these routes may also constrain any future plans to increase the capacity of these facilities so they can accommodate more trains.

To the south of Cardiff, the Cardiff Bay branch is a single line, as are the Penarth and Barry Island branches.

The industry planning process that underpins this Route Study has identified that some of these single line sections are a long term strategic constraint to aspirations for future growth, capability and connectivity.

The analysis suggests that the most obvious single lines for further consideration are those on the Treherbert and Rhymney lines taking consideration the stabling facilities at these locations. Redoubling these lines would unlock the potential to stable more trains at these locations provided that more yard space is feasible.

This Route Study concludes that a Choice for Funders in CP6 (and potentially beyond) is to redouble these single lines on an incremental basis, subject to feasibility, business case and affordability.

Figure 5.2: Cardiff Capital City Region Metro (from the Strategic Implementation Plan)

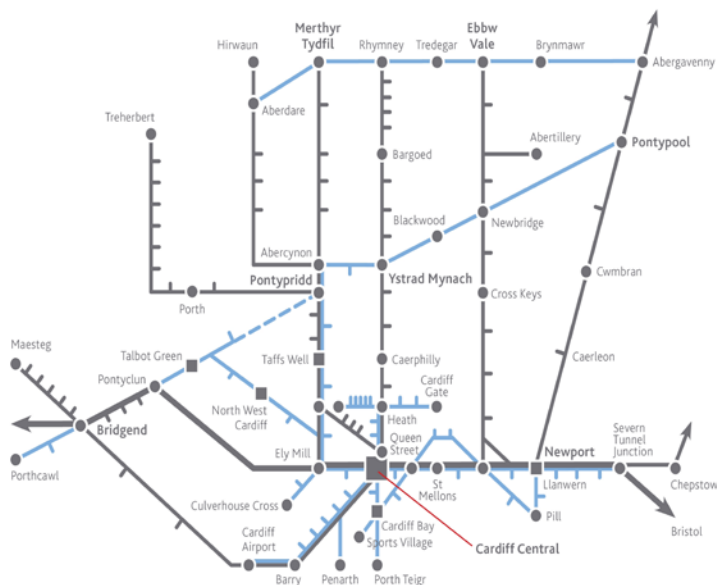

Table 5.3 Assessment of Option A: Upgrade of Relief Lines between Cardiff Central and Severn Tunnel Junction to a comparable speed profile to the Main Lines.

Summary of intervention:

This network enhancement will provide additional capacity and reduce journey times for services that require to be routed along the Relief Lines between Cardiff Central and Severn Tunnel Junction.

Output assessment:

Maximise capability afforded by recent re-signalling of the route to provide a line speed profile on the Relief Lines comparable with the existing Main Lines. The closure of Bishton Level Crossing with alternative access provided is included within this option.

This goes towards meeting the requirements of Conditional Outputs CO1 and CO30, while also acting as an enable for future longer term requirements to deliver enhanced network capacity to 2043.

Affordability assessment

Engineering feasibility and appraisal of this option will be reported in the final Welsh Route Study.

Table 5.4 Assessment of Option B: Upgrade of Main and Relief Lines between Cardiff Central and Severn Tunnel Junction to maximise the capability provided by the recent re-signalling and achieve a maximum speed capability of 100 mph.

Summary of intervention:

This network enhancement will provide additional capacity and reduce journey times for services between Cardiff Central and Severn Tunnel Junction.

Output assessment:

Maximise capability afforded by recent re-signalling of the route to provide a headline maximum line speed of 100 mph.

This goes towards meeting the requirements of Conditional Outputs CO1 and CO30, while also acting as an enable for future longer term requirements to deliver enhanced network capacity to 2043.

Affordability assessment

Engineering feasibility and appraisal of this option will be reported in the final Welsh Route Study.

5.1.3 Option 3: Upgrade of Relief Lines line speed between Severn Tunnel Junction and Cardiff Central

The South Wales Main Line between Severn Tunnel Junction and Cardiff Central is the busiest main line within Wales. It is a four-track railway line conveying both passenger and freight services.

This four-track railway has two Main Lines along which most passenger services are routed. These main lines have a maximum operating speed of 95 mph for HSTs (High Speed Trains) and 75 mph for DMUs (Diesel Multiple Units) whilst the two Relief Lines have a much slower maximum operating speed of 60 mph. The Relief Lines are used predominantly by freight services and during times when the Main Lines are closed during planned maintenance or when operation is perturbed for any reason.

The maximum number of planned services that operate on the busiest stretch of line between Cardiff Central and Newport in the baseline of 2019 in any hour is nine passenger trains. Given the different operating capabilities of the rolling stock used, this can at times mean that there is little additional network capacity available on this part of the network without compromising performance.

In CP5 there are plans to increase the frequency of passenger services between Cardiff Central and Ebbw Vale (see [Section 2.3](#)). As currently envisaged any additional service will need to operate along the Relief Lines due to timetable and network capacity constraints with consequential journey time penalty.

Additionally, in the medium to longer term, [Chapter 3](#) has highlighted the growing passenger demand between Cardiff and London and Cardiff and Bristol. With these routes being electrified in CP5, and the existing Wales and Borders and Great Western passenger franchises being due for renewal within the next five years, the opportunities to introduce additional services between these locations (and indeed to other locations for which this arterial route is an important node) will be constrained by the current track layout configuration which would require additional services to operate along the slower Relief Lines with consequent journey time penalty.

[Section 6.2.2](#), considers the longer term requirements for this route out to 2043 and identifies the need to upgrade the route to provide

four lines with the same operating capability. A choice for funders in CP6 is therefore to start this programme by upgrading the existing Relief Lines to the same standard as the existing Main Lines. Recent re-signalling of the route has provided signal spacing to enable line speeds of up to a maximum of 100 mph to be achieved subject to bringing other assets such as track up to a comparable standard. Therefore maximising the capability afforded by the recent re-signalling works is seen as opportune given the emerging medium term requirements identified, and potential additional services on this part of the network. This will also enable improved service delivery to be provided when two of the four lines are closed for maintenance.

[Tables 5.3](#) and [5.4](#) describes the assessment of options to deliver improved journey time opportunities by upgrade of the Relief Lines between Cardiff Central and Severn Tunnel Junction. Option A outlines the upgrade described above while Option B considers the incremental opportunity of providing maximum line speeds of up to 100 mph where this capability is afforded by the recent re-signalling works.

5.1.4 Option 4: Cardiff Central Station – a station fit for a capital city

Cardiff Central Station is by far the busiest in Wales in terms of passenger numbers and train services.

As stated in [Chapter 3](#), sustained growth in demand for travel into Cardiff over the next 10 to 30 years is expected. Indeed, the number of passengers using Cardiff Central Station could grow from 13 million in 2013 to 23 million by 2023 and to 33 million by 2043.

The station layout, which originates from 1934, will need to provide much more capacity in order to satisfy the forecast demand growth. Put simply, the railway station will need to satisfy more people, more often.

A modernisation of the station is rapidly required. The railway needs to deliver three key outputs:

- More capacity for passengers and more capacity for trains (including extending Platform 0 into a full length facility for Intercity Express Programme (IEP) trains)
- Better customer experience
- Spatial integration with the city centre and new bus station.

As the station is at the heart of the city centre's financial and professional services district, which will include a new BBC headquarters, there are multifaceted development, funding and delivery options for creating a station fit for a capital city.

The development will include improved facilities to cater for large volumes of passengers attending events at the adjacent Millennium Stadium.

While some initial work is already underway, largely driven by the new BBC facility and a new bus station, more development work needs to be undertaken to understand the different options for the station itself. This work could be completed in CP5.

This Route Study concludes that a choice for funders in CP6 is the modernisation of Cardiff Central Station so that the railway can continue to play its part in supporting economic growth and prosperity in the capital city of Wales.



5.1.5 Option 5: Continued programme of level crossing closures in South West Wales

Following electrification of the South Wales Main Line to Swansea during CP5, this will in the medium to longer term provide the opportunity to convert passenger services from diesel traction to electric traction to Swansea. Opportunities to extend services west beyond Swansea will therefore require trains to be capable of operating both electrically and on diesel engines (bi-mode technology), or remain diesel operated.

In the shorter term there are opportunities to look at where journey times might be improved in South West Wales to offer significant journey time improvement on this rural part of the network. During CP5 Network Rail is continuing to look at opportunities for closing level crossings which remain the single biggest safety risk on the network. This work builds on the already significant achievements in closing many crossings across the UK rail network during CP4, and does provide a natural strategic alignment on parts of the more rural network where journey time improvements are also required.

The route from Whitland to Pembroke Dock has a number of open level crossings that require trains to stop on the approach before continuing across the level crossing. This provides a significant journey time penalty along the route. Network Rail will continue to assess the options associated with closure of these crossings with local authorities and how these might be funded given the safety and potential journey time improvement benefits that could be accrued. Additionally, discussion will also continue with governments, regional and local authorities as to what future train services might be specified as reduction of journey time might also enable more efficient resource of rolling stock deployment on such routes.

These opportunities will assist in seeking to deliver Conditional Output CO37.

5.1.6 Option 6: Continuation of recently announced additional services on Heart of Wales Line

The Heart of Wales Line is a single line with passing places through the rural landscape of Mid and South Wales. Four passenger services run in each direction per day, usually between Swansea and Shrewsbury, serving the considerable number of local stations along this route, some of which are the most remote in Wales. Additional peak time services will be introduced on a three year trial basis from May 2015, running between Llandovery and Swansea in the south, and Llandrindod and Crewe in the north. Additional peak time arrivals at either end of the route will also provide earlier connectional times to other key Welsh and UK destinations.

Continuation of these services in the medium to longer term will deliver Conditional Output CO38.



5.1.7 Option 7: Selected train lengthening on Marches Line services

There is expected to be a capacity gap on the Cardiff – Manchester services via the Marches by the end of CP6. Details of the passenger demand analysis are discussed in Section 4.1.6. This capacity gap can be met through train lengthening.

Cardiff to Manchester services are operated with two-car or three-car trains, lengthening these services with additional vehicles will deliver sufficient capacity to accommodate forecast demand growth on these services.

Tables 5.5 and 5.6 describe the assessment for the train lengthening option.

Table 5.5. Assessment of Option A: Train lengthening for services between Cardiff and Manchester using five additional vehicles (CO5 & CO6)
<p>Summary of intervention: The train lengthening option is considered to provide additional capacity to meet the anticipated demand between Cardiff and Manchester (via the Marches) by the end of CP6.</p>
<p>Output assessment: Lengthening the anticipated 2019 two-car and three-car services between Cardiff and Manchester with one or two extra vehicles to serve rail passenger demand on services where extra capacity would be required. This goes towards meeting the requirements of CO5 and CO6, providing sufficient capacity to meet passenger demand growth for the long distance market between Cardiff and Manchester, also the commuting demand between local stations on the Marches.</p>
<p>Affordability assessment An appraisal has been carried out to demonstrate that providing five additional vehicles to lengthen the selected two-car and three-car Cardiff- Manchester services. The option represents a low value for money case for investment in CP6. Further detail of the appraisals is included in Appendix A.</p>

Table 5.6. Assessment of Option B: Train lengthening for services between Cardiff and Manchester using two additional vehicles (CO5 & CO6)
<p>Summary of intervention: The train lengthening option is considered to provide additional capacity to meet the anticipated demand between Cardiff and Manchester (via the Marches) by the end of CP6.</p>
<p>Output assessment: Lengthening the anticipated 2019 two-car services between Cardiff and Manchester with one extra vehicle to serve rail passenger demand on services where extra capacity would be required. This goes towards meeting the requirements of CO5 and CO6, providing sufficient capacity to meet passenger demand growth for the long distance market between Cardiff and Manchester, also the commuting demand between local stations on the Marches.</p>
<p>Affordability assessment An appraisal has been carried out to demonstrate that providing two additional vehicles to lengthen the selected two-car Cardiff- Manchester services. The option represents a financially positive case, equivalent to a very high value for money categorisation, for investment in CP6. Further detail of the appraisals is included in Appendix A.</p>

Table 5.7. Assessment of Option A: Provision of 25kV electrification from Crewe/Warrington and Llandudno/Holyhead via Chester

Summary of intervention:

This network enhancement will deliver a fully electrified railway between North Wales and London, Liverpool (assuming Halton Chord is also electrified) and Manchester enabling all passenger services on these routes to operate using electric passenger rolling stock.

Output assessment:

Electrification of the route(s) between Crewe/Warrington and Llandudno/Holyhead via Chester will deliver improved connectivity between North Wales and London, Liverpool and Manchester.

This goes towards meeting the requirements of Conditional Outputs CO21 CO22, CO23 and CO24.

Affordability assessment

Appraisals have been carried out to assess the financial viability of the options outlined in Section 5.1.8 and this identifies that the options assessed represent a poor value for money case for investment in CP6. Further details of the appraisals are included in Appendix A.

5.1.8 Option 8: Modernisation of the North Wales Coast Main Line

The Welsh Government and local and regional authorities want to see the modernisation of the network in North Wales, and this builds on Network Rail's committed plans for modernising signalling assets during CP5 and CP6. This is considered important to provide improved connectivity and reduced journey times between North Wales and London (potentially by future connectivity to High Speed 2 (HS2), Liverpool and Manchester).

As part of this initiative, Network Rail has developed a socioeconomic case on behalf of Welsh Government for electrification of the route(s) between Crewe/Warrington and Llandudno/Holyhead via Chester. In parallel with this, the North Wales Economic Ambition Board has undertaken work to identify and quantify the wider economic benefits to North Wales that could be achieved by modernisation of the route and the specification of additional services to London, Manchester and Liverpool (via Halton Chord, for which enhancement investment has recently been announced by UK Government).

Network Rail's study reviewed a number of potential passenger service specification options which resulted in a range of appraisal results.

The base case option considered conversion of a number of existing diesel passenger services (that operate today) to electric passenger services where these existing services already operate over electrified routes for significant parts of their journeys. In this case the services assumed to be converted from diesel operation to electric operation are:

- services between London Euston and Chester/North Wales in both directions
- services between Manchester Piccadilly and North Wales in both directions
- services between Chester and Crewe in both directions.

An option that would provide an improved business case would require a greater number of passenger services to be specified along the North Wales Coast. Welsh Government therefore requested

that an assessment be undertaken using the passenger train service specification developed for the 2043 Indicative Train Service Specification (ITSS) (see Section 4.5). This assessment assumes that the existing diesel passenger services that operate today and are set out in the base case above, are converted to electric passenger services as in the base case. The additional passenger services specified would include:

- All London Euston services that currently terminate at Chester would be extended into North Wales providing an hourly service between London Euston and North Wales (Bangor/Holyhead) in each direction
- An additional service in each hour between Manchester Piccadilly and Llandudno in each direction
- A new direct service between Liverpool and North Wales (Bangor/Holyhead) in each direction.

It is important to note that the business case assessed for this high frequency service option includes only the capital costs of electrification infrastructure, and the costs of converting existing diesel services to electric services. It does not assess the business case for the introduction of the new/additional services specified in the 2043 ITSS for which operating subsidy would likely be required.

Table 5.7 describes the assessment of the option to electrify the network using 25kV overhead electrification between Crewe/Warrington and Llandudno/Holyhead via Chester.

While the economic appraisal of this proposal offers a low value for money case, there are other potential economic and policy drivers for change that could be developed in CP6. Additionally, it should be noted that the case for electrifying the route from Crewe to Chester provides a high value for money investment, although a journey time penalty for passengers travelling to and from North Wales, so consideration is required between governments as to how an overall scheme including North Wales might be funded and phased. This is particularly important in terms of future passenger service specification in northern England, and future rolling stock strategy



Table 5.8. Assessment of Option A: Improve linespeeds along North Wales coast between Chester and Llandudno/Holyhead

<p>Summary of intervention: This network enhancement will deliver higher linespeeds along the North Wales Coast to maximise the capability afforded by the signalling renewals.</p>
<p>Output assessment: Reduction in journey time between Chester and Llandudno/Holyhead. This goes towards meeting the requirements of Conditional Outputs CO21 CO22, CO23 and CO24.</p>
<p>Affordability assessment An appraisal has been carried out assessing the financial viability of this option and this identifies that the option represents a financially positive case, equivalent to a very high value for money categorisation for investment in CP6. Further detail of the appraisals is included in Appendix A.</p>

Figure 5.3: Shotton - Existing layout

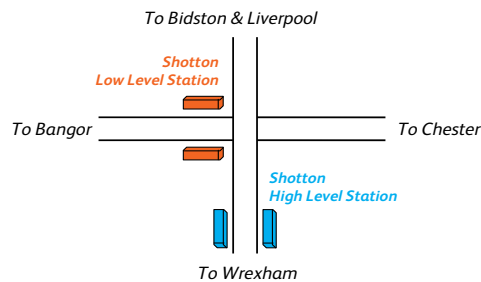
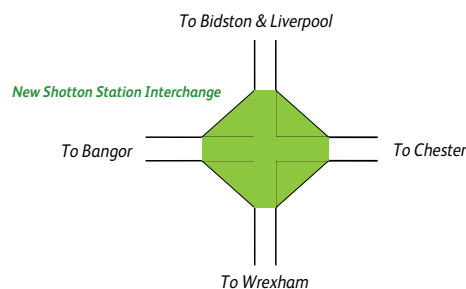

Figure 5.4: Shotton Station Interchange - proposed layout



5.1.9 Option 9: Improved linespeeds along North Wales Coast Main Line

Re-signalling of the North Wales Coast Main Line between Rockcliffe Hall (west of Chester) and Llandudno/Holyhead, is planned to be delivered by early CP6. In addition track renewals are planned to be undertaken during CP5. Phase 1 of the signalling programme will see the route re-signalled between Rockcliffe Hall and Llandudno Junction during CP5, with Phase 2 re-signalling the remainder of the route by early CP6.

The signalling design provides capability for improving linespeed up to a maximum of 100 mph where conditions allow. Renewal of the signalling system and some track components will therefore provide latent capability for higher linespeeds. To enable this latent higher linespeed capability to be fully exploited, further work will be required to improve track geometry and provide the necessary route clearances.

Analysis of this option has indicated that, depending upon the stopping patterns of trains and their origin/destination points (Llandudno/Holyhead), a maximum journey time saving of up to eight minutes could potentially be achieved for the long distance limited stop services between Chester and Holyhead. Services that stop at more stations along the route do still achieve journey time savings of up to three minutes between Chester and Holyhead, with services between Chester and Llandudno (that call at most stations) achieving about a one minute journey time saving.

The opportunity of using CP5 ringfenced funding to undertake this work is currently being investigated. Should funding not be identified in CP5 this intervention should be considered as a choice for funders in CP6 as it aligns with the medium to longer term aspirations to modernise the North Wales Coast Main Line (see [Section 5.1.8](#))

[Table 5.8](#) describes the assessment of this option to deliver improved journey time between Chester and Llandudno/Holyhead.

5.1.10 Option 10: Shotton Station

The growth in demand for better connectivity between North East Wales and Merseyside provides an opportunity to think again about the purpose and functionality of Shotton Low Level Station (on the North Wales Main Line) and Shotton High Level Station (on the Wrexham to Bidston Line).

[Sections 5.1.8, 5.1.9 and 5.1.12](#) of this chapter identify a range of proposed interventions along the North Wales Coast Main Line and between Wrexham and Bidston, that are choices for funders in CP6 and that act as a step to accommodate future required improvements in connectivity including access to the Deeside Industrial Area that is not currently well served by rail.

Interchange between the two stations is not easy as they are in different locations even though one line goes over the other. [Figures 5.3 and 5.4](#) sets out the before and after scenarios.

Opportunities exist to improve the interchange potential at this location by creating one modern station that serves both lines albeit on two different levels and, also, through timing services so that interchanges can be optimised. More and better car parking facilities could also be provided.

A transport planning study that considers all modes of travel is recommended as a next step to inform the feasibility, value for money and affordability of this potential scheme.

A potential choice for funders in CP6 is therefore to commence development of work to consider options for improving Shotton Station which will take into consideration a number of future factors such as:

- improved interchange between routes (given potential future increased service specification on both routes)
- improved passenger facilities
- associated wider planning and access requirements including integrated transport links.

Table 5.9. Assessment of Option A: Deliver the ability to provide an additional passenger service in each hour between Chester and Wrexham

Summary of intervention:

This network enhancement will require the redoubling of the remaining single line section between Saltney Junction and Wrexham General and layout changes at Wrexham General.

Output assessment:

Deliver increased network capacity between Chester and Wrexham General.
This goes towards meeting the requirements of Conditional Output CO28.

Indicative cost:

£35 - 75 million.

Affordability assessment

Engineering feasibility work has assessed the likely range of capital costs to redouble this part of the network.
Appraisal work is currently being undertaken to assess the financial viability of this option taking consideration of enhanced passenger service levels between Wrexham and Liverpool/Manchester.
The appraisal results will be reported in the final Welsh Route Study publication.

5.1.11 Option 11: Network capacity enhancement between Wrexham General and Chester

In developing this Welsh Route Study, the role that rail can play in improving connectivity between North Wales/Wrexham and Liverpool/Manchester has been highlighted as one of high strategic importance. The economies of North Wales, Deeside, Merseyside and Manchester are closely linked and the road networks in this part of the country are operating at maximum capacity during peak times. As part of a range of transport improvements in the North West, UK Government has recently announced plans to enhance the Halton Chord to enable operation of regular direct train services between Liverpool and North Wales/Wrexham.

The Welsh Government has been working with Merseytravel and Network Rail to explore options for delivering improved connectivity between Liverpool and Wrexham, and has also been in discussions about how future train services operating in the north of England might be extended to destinations in North Wales – including Wrexham. To enable such additional services to operate between Chester and Wrexham, the remaining single line section between Wrexham and Rossett would need to be redoubled. For the avoidance of doubt, reference to additional services means those over and above those specified as part of the current North - South Journey Time Improvement scheme which is in the process of delivery.

Table 5.9 describes the assessment of this option to increase network capacity between Chester and Wrexham General.

5.1.12 Option 12: Improved linespeeds between Wrexham and Bidston

During CP5 Network Rail is continuing to look at opportunities for closing Level Crossings (including user and footpath crossings) which remain the single biggest safety risk on the network.

During CP4 track renewals have been completed on parts of this route. Where these track renewals have been undertaken, opportunity exists to raise linespeeds subject to closing or upgrading level crossings.

By delivering improved journey times along the route, this will also improve the performance of the route where current end to end journey time between Wrexham Central and Bidston is approximately one hour with minimal turn around times at each end of the route.

During CP5 and CP6 options for improving the service offering on this route will be further developed, working closely with local and regional stakeholders.

5.1.13 Option 13: Commuting into Shrewsbury from the Cambrian Main Line

No specific capacity issues are envisaged in peak hour commuting into Shrewsbury from origin points in the Welsh Route Study area during CP6. However, it is recognised that the ability to commute into Shrewsbury by rail from locations situated on the Cambrian Main Line (particularly Newtown and Welshpool) are currently constrained by the current timetable which offers limited morning peak arrival time opportunities and also limited evening peak departure time opportunities.

With effect from May 2015, for a trial period of three years, Welsh Government is funding additional services on this route which will provide an hourly service during peak times and which improve the ability to commute into Shrewsbury from the Cambrian Main Line. These additional services will also provide improved connectivity into Aberystwyth at the west end of the route.

Continuation of these services in the medium to long term will therefore deliver improved connectivity along the route. It will also provide additional capacity to meet any constrained demand and at such times as when services on the route are particularly busy either prior to the start of or at the end of student term times at Aberystwyth University.

06: Longer Term Strategy to 2043

Highlights:

This chapter sets out the strategy for the period 2024-2043.

Demand for rail is expected to continue to grow in this period.

There is a positive correlation between the long term future of the economy and the long term future of the railway.

Planning for the future starts now so there is a clear line of sight for the next 30 years.

6.0 Context

In this chapter the Route Study highlights the longer term choices for funders to accommodate the Conditional Outputs set out in the established Market Studies and the Welsh Route Study to 2043. In each case the approach has been to establish the long term challenges in meeting the Conditional Outputs and ensure that the Control Period 6 (CP6) options set out in Chapter 5 are consistent with the potential longer term solutions set out in this chapter. As this chapter covers options for beyond CP6, appraisals have not been included at this stage though in some cases some initial engineering feasibility, operational planning and costing work has been completed.

6.1 Developing the longer term strategy

In developing the longer term strategy for the Wales Route, several key aspects have been used as fundamental building blocks:

1. the Wales Route Modernisation Plan
2. digital train control technology
3. safety
4. the 2043 Indicative Train Service Specification (ITSS).

6.1.1 The Wales Route Modernisation Plan

The Wales Route Modernisation Plan sets out Network Rail’s plans to modernise the infrastructure and train control technology on a phased basis throughout the Welsh network. While the Plan is hinged on re-signalling schemes, it offers a series of ‘once in a generation’ opportunities to further enhance the network in the areas being re-signalled to deliver longer term growth in demand for rail services. This is particularly relevant for this Welsh Route Study as it allows choices for funders to be developed as part of the Modernisation Plan.

The Wales Route Modernisation Plan is set out in [Figure 6.2](#).

Figure 6.2: Wales Route Modernisation Plan

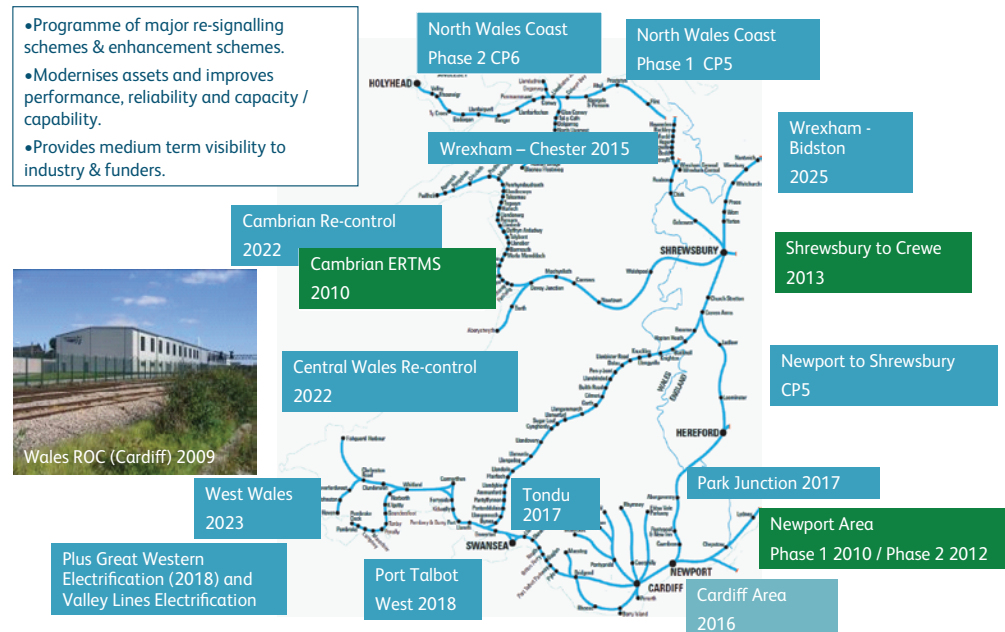

- Programme of major re-signalling schemes & enhancement schemes.
- Modernises assets and improves performance, reliability and capacity / capability.
- Provides medium term visibility to industry & funders.

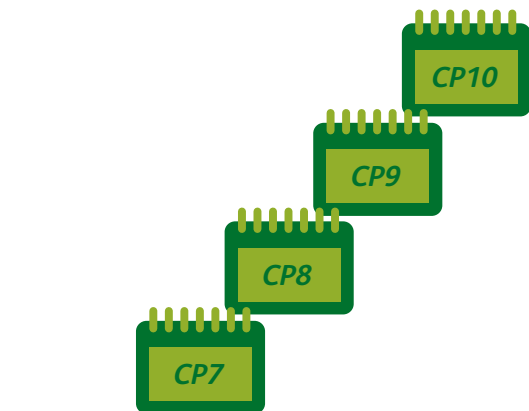

Figure 6.1: Choices for funders to 2043

6.1.2 Digital Railway

The railway industry is developing a business case for the acceleration of the Digital Railway across the network. This Route Study is one of a number of route studies that will help inform the case for the Digital Railway.

The Digital Railway could deliver the following outputs:

- Additional capacity
- Improved passenger experience
- Train control and operation
- Asset management
- Stations and interchanges.

The accelerated introduction of European Train Control System (ETCS) underpins the train control element of the Digital Railway.

For the purposes of the Welsh Route Study this has been considered at a high level. The introduction of ETCS onto the network, coupled with the continued development of this technology, may support the creation of longer term solutions to some of the network capability constraints identified in this chapter. Therefore the assessment of these future anticipated network constraints identifies what additional network capability will be required in the future thus informing the development of ETCS.





Other than a trial installation on the Cambrian Route, there is no further ETCS signalling currently planned in Wales in the short to medium term. Further installation will follow train fitment and the movement of ETCS westward along Anglo-Welsh routes. All current and future modular signalling renewals are technologically compatible with future fitment of ETCS.

Section 6.2 considers the longer term vision for the network within Wales and the Borders on a route by route basis. It seeks to highlight where Digital Railway train control may ultimately support areas where network capability enhancements are required to deliver the Conditional Outputs necessary by 2043.

Table 6.1 summarises the potential for ETCS to address future network capacity constraints without the need (either in part or in full) for major civil engineering works and therefore providing the capacity outputs in a more affordable and efficient manner.

The busiest parts of the Welsh rail network are the Valley Lines in South East Wales and the South Wales Main Line between Severn Tunnel Junction and Cardiff Central. It is considered that in the longer term (beyond CP6), these parts of the network offer the most potential for early deployment of ETCS, particularly if future development of this system delivers the ability to further increase capacity on the network whilst also avoiding the need for more costly and disruptive civil engineering solutions.

Table 6.1 Potential for ETCS to address future capacity constraints and avoid major capital cost infrastructure enhancements		
Route	2023 capacity requirements	2043 capacity requirements
Bristol Parkway - Swansea	Relief Line speed increase required	Some interventions likely to be required to utilise DR potential
Cardiff Valleys		Redoubling of some single lines may be required
South West Wales		
Newport - Shrewsbury		Extension/relocation of freight loops likely to be required
Shrewsbury - Chester		Full redoubling likely to be required
North Wales Coast		
Cambrian	ETCS Level 2 in operation. No additional capacity requirements to 2023.	
Shrewsbury - Crewe		
Wrexham - Bidston		

-  No capacity increase required/demand already met
-  Potential for DR alone to meet capacity requirements
-  Some infrastructure works likely to be required alongside DR
-  Major infrastructure works likely to be required alongside DR

6.1.3 Safety

The rail industry has made significant progress in recent years in improving safety on the rail network. More can be done in this area to drive continuous improvement in passenger and work place safety.

In considering the future of the network, [Section 6.1.2](#) sets out how digital technology is being embedded into the future strategic vision for the railway. Digital train control not only offers significant opportunity to deliver additional network capacity, it will also provide the ability to control trains in a safer manner and reduce the need in the future to maintain line side signalling equipment reducing the need for railway industry staff to be exposed to the open operating railway environment.

This Route Study considers the reduction of risk at level crossings when assessing all future interventions on a linear basis. This means that reducing risk at level crossings is embedded into the strategic vision for the network. The reduction of risk at level crossings is included in the choices for funders where appropriate.

6.1.4 2043 Indicative Train Service Specification (ITSS)

[Chapter 4](#) explained how the 2043 ITSS has been developed for Wales. The Welsh Route Study has used the 2043 ITSS and the freight forecasts for 2043 (extrapolated into numbers of trains) to provide a guide for how the network should be developed. This chapter therefore assesses how these factors might be accommodated on the network in the future by:

- firstly making best use of the baseline (2019) network infrastructure
- secondly considering what future network capability enhancement is required.



6.2 Accommodating the Conditional Outputs to 2043

6.2.1 Introduction

The following sections set out future choices for funders to deliver the range of Conditional Outputs identified in the longer term to 2043. These follow broad geographical routes related to the longer term interventions that have been developed as future choices for funders by the Welsh Route Study. Where an intervention has been identified, it is related to which Conditional Output is accommodated by delivery of the relevant intervention.

6.2.2 Bristol Parkway/Gloucester (via Chepstow) to Swansea including Maesteg and Ebbw Vale lines (South Wales Main Line)

6.2.2.1 Overview of the South Wales Main Line as a whole

The South Wales Main Line is the arterial route connecting Cardiff with destinations across England and Wales. It runs through Bristol Parkway, Patchway and the Severn Tunnel as a double track line, becoming a four-track layout at Severn Tunnel Junction, where the Gloucester to Newport Line joins. It remains as four tracks, grouped into two pairs – the Up and Down Main and Up and Down Relief Lines – as far as Cardiff Central, where it reverts to a two track line serving a number of intermediate stations. Another significant junction is Maidee West Junction, just east of Newport station, where the Marches route joins the South Wales Main Line.

There are also a number of junctions with smaller branch lines, including the Ebbw Vale and Maesteg branches. Although technically Valley lines, these are included in this chapter because all their services use the South Wales Main Line running through Newport or Cardiff. There are also links to the Vale of Glamorgan Line at Cardiff and Bridgend, which is considered under [Section 6.2.4](#), and a number of freight-only lines. There are multiple rail connections into industrial complexes, particularly around Newport and Port Talbot.

The South Wales Main Line is intensively used by a mix of long distance, regional and local passenger services, alongside heavy freight trains, and is forecast to see substantial growth in the next 30 years. The 2043 ITSS and 2043 freight forecast are shown alongside the 2019 baseline services in [Figure 6.3](#).

Figure 6.3: South Wales Main Line 2019 baseline and 2043 ITSS

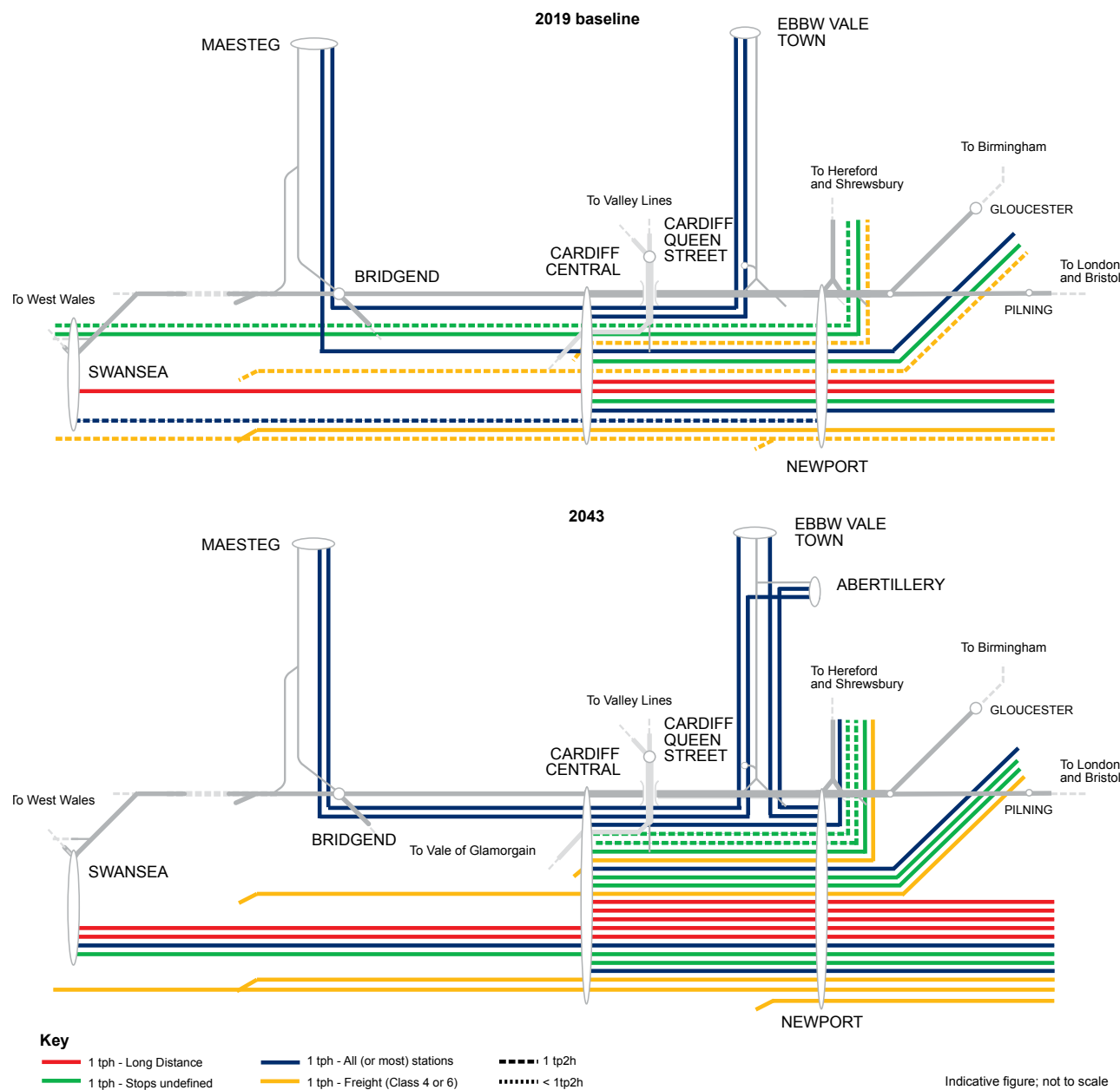

The South Wales Main Line as currently used, with passenger services operating at different speeds on the Main Lines, and freight on the Relief Lines, is already operating at a level close to capacity. Therefore, the required increase in service frequency and intensity will necessitate a rethink of the operation of this line, and the utilisation of facilities at Newport and Cardiff Central stations. Any increase over today's level of service using the South Wales Main Line, even towards meeting CP6 requirements, is likely to require routine use of the Relief Lines for enhanced levels of passenger services.

Section 5.1.3 sets out a choice for funders to upgrade the Relief Lines between Severn Tunnel Junction and Cardiff Central, to provide broadly the same level of operating capability. The longer term strategy for this route set out below builds upon this intervention to meet the requirements out to 2043.

The Severn Tunnel limits the number of services that can be routed directly between London / Bristol and South Wales. This is because there are no intermediate signals within the tunnel itself which means that the signalling section is relatively long which limits future capacity. The 2043 ITSS can only be accommodated, therefore, through redirecting two passenger services via Gloucester, a finding which is in line with the conclusions of the Western Route Study. For the avoidance of doubt, these additional services are longer term aspirations developed by the market studies and are not committed or specified in the baseline.

One of the main consumers of capacity from Severn Tunnel Junction to Cardiff Central is crossing moves (the crossing of one service, via a junction, over the route required by another). This is particularly critical at Severn Tunnel Junction, and at Maidee West Junction outside Newport. Therefore, this Route Study has assessed in detail two longer term operating philosophies to deliver the 2043 ITSS on this part of the network. These two philosophies assess the options for reducing crossing moves at these key points as far as possible, therefore freeing up capacity to operate more services.

Two models are required because each addresses different constraints, and therefore drives different service and performance trade-offs and infrastructure interventions. These are detailed in Tables 6.2 and 6.3.

Figure 6.4: South Wales Main Line Routeing philosophies

Table 6.2 Routing Model 1: minimal crossing moves

This model is built on the basis of minimal crossing moves between the Relief and Main Lines, thereby restricting the interventions necessary at Severn Tunnel Junction. However, it drives other infrastructure requirements, including the need for an additional platform serving the Main Lines at Newport. As many passenger services as possible are routed along the Main Lines, limiting the number of services sharing the Relief Lines with freight.

The 2043 ITSS and 2043 freight forecast can be accommodated in theory if all passenger services between Severn Tunnel Junction and Cardiff Central have similar operating characteristics which it is assumed is likely by 2043. This solution is built around the assumption that services from London, Bristol and Shrewsbury can be timetabled to arrive and depart the South Wales Main Line at consistent intervals and times. If this is not achievable due to network constraints elsewhere, further service trade-offs or infrastructure interventions will be required. See Figure 6.4.

Table 6.3 Routing Model 2: reduction of crossing moves through grade separation

This model avoids the need to reconfigure or extend Newport station, but requires a grade separated crossing in the vicinity of Severn Tunnel Junction, wider signalling improvements, and increases the number of passenger services mixing with freight on the Relief Lines.

The 2043 ITSS and 2043 freight forecast can be accommodated in theory if all passenger services between Severn Tunnel Junction and Cardiff Central have similar operating characteristics which it is assumed likely by 2043. This solution is built around the assumption that services from London, Bristol and Shrewsbury can be timetabled to arrive and depart the South Wales Main Line at consistent intervals and times. If this is not achievable due to network constraints elsewhere, further service trade-offs or infrastructure interventions will be required. See Figure 6.4.

Current Routeing Philosophy

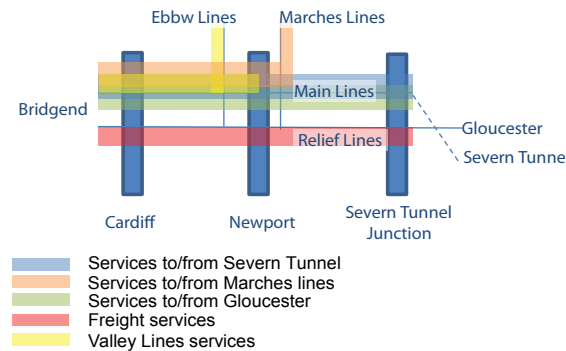

Constraints

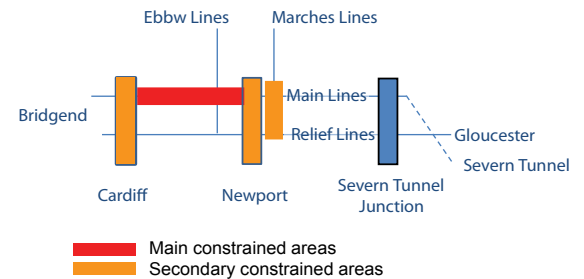

Routeing Philosophy 1

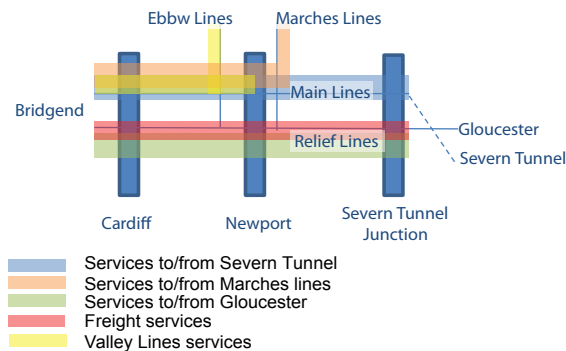

Constraints

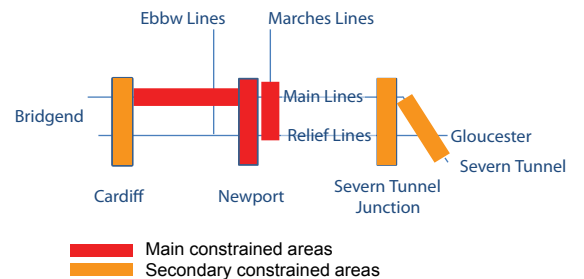

Routeing Philosophy 2

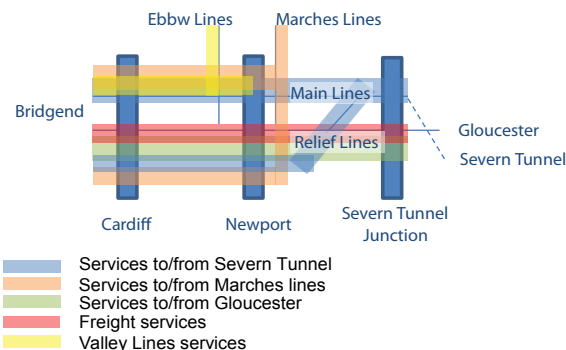

Constraints

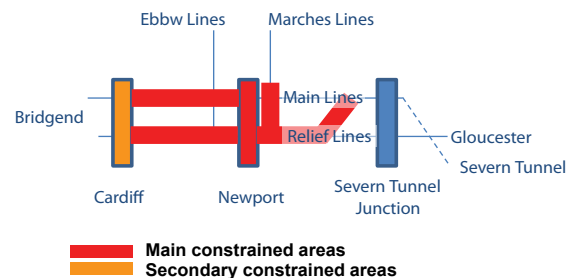

There is a 'hierarchy of constraints' between Severn Tunnel Junction and Cardiff Central. There are five critical points: the Severn Tunnel, Severn Tunnel Junction, Newport, Cardiff Central, and the line between Severn Tunnel Junction and Cardiff Central. Each of these restricts the total number of trains that can be accommodated on the South Wales Main Line to some degree, and each will need to be addressed in order to meet the 2043 ITSS and 2043 freight forecast. These constraints, and their relative severity, are illustrated in [Figure 6.5](#).

The constraints, trade-offs and possible infrastructure interventions driven by the two Routeing Models are now considered in depth on a section-by-section basis.

6.2.2.2 Gloucester/Patchway to Severn Tunnel Junction (inclusive)

Overview

The line between Gloucester and Severn Tunnel Junction winds along the northern bank of the River Sever, serving three intermediate stations. Double tracked, it currently accommodates a mix of regional and local passenger services, and freight trains. These flows are forecast to increase in the 2043 ITSS and 2043 freight forecast.

The line between Patchway and Severn Tunnel Junction is dominated by the Severn Tunnel, which takes the line between England and Wales under the Severn Estuary. Double track throughout, it accommodates a mix of Long Distance High Speed, regional and local passenger services, and freight trains. These flows are envisaged to increase significantly in the 2043 ITSS and 2043 freight forecast.

Figure 6.5: SWML hierarchy of constraints

South Wales Main Line baseline infrastructure

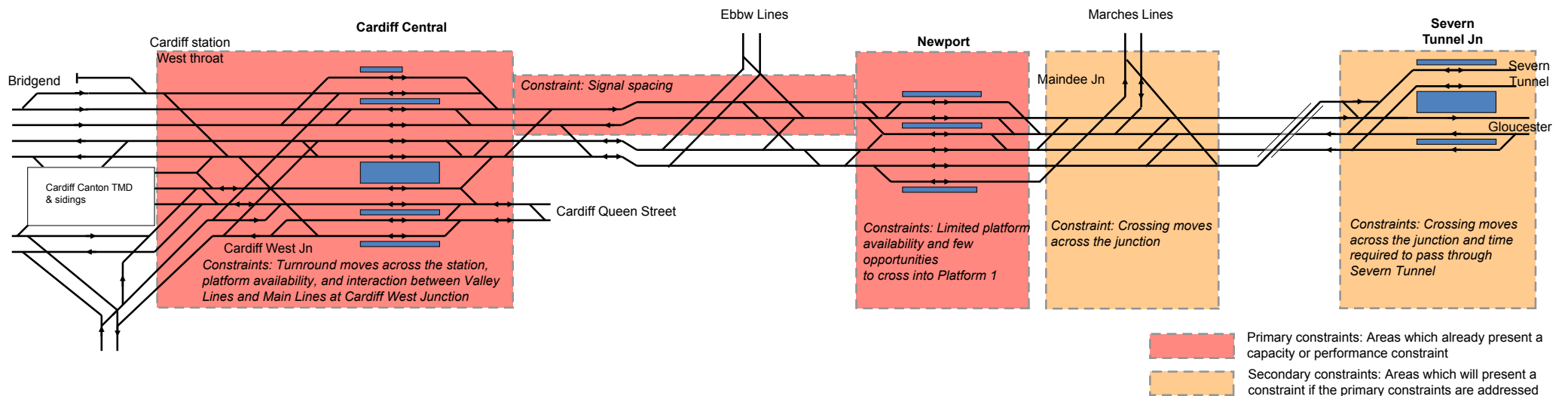

Constraints in 2043

There are two constrained areas in this section: the Severn Tunnel itself, and Severn Tunnel Junction. Other pieces of infrastructure are theoretically capable of accommodating the level of service required to 2043.

The tunnel can, in theory, accommodate up to nine trains per hour in each direction. These nine trains may consist of either eight passenger services and one freight train, or seven passenger services and two freight trains. The 2043 ITSS and 2043 freight forecast indicate that eleven paths per hour are required.

Severn Tunnel Junction can theoretically accommodate up to nine trains passing to and from the Severn Tunnel, alongside five services to and from the Gloucester lines. This includes one freight train passing to and from the Relief Lines through the Severn Tunnel. However, this takes occupation to its maximum practical level. Additionally, this presumes the ability to provide optimum timings over this junction, which is likely to be difficult to achieve given network constraints elsewhere.

There are some additional safety requirements placed on certain freight trains operating through the Severn Tunnel conveying dangerous goods, where no other services may operate through the tunnel in the opposite direction at the same time.

Making best use of current infrastructure, up to 2043 specification

The maximum number of services that can be run through the Severn Tunnel is nine, including one or two freight trains. Therefore, at least two of the passenger services specified in the 2043 ITSS cannot be accommodated through the tunnel. However, the two planned services between Cardiff and Gloucester via Bristol Parkway could be routed along the direct route between Severn Tunnel Junction and Gloucester, since there is sufficient capacity along this line.

While this routing alteration, in theory, would permit the accommodation of the 2043 ITSS east of Severn Tunnel Junction, it is likely that the junction itself would become a constraint. Even assuming a fundamental change in routing along the South Wales Main Line, to either Model 1 or 2 above, it would only be possible to timetable all the required services over this junction by timing them

to arrive in the optimum pattern. This would entail building the South Wales Main Line timetable around this point, which may not be possible given more constrained parts of the networks through which these services also operate.

Severn Tunnel Junction is likely, therefore, to drive service trade-offs or require an infrastructure intervention before the anticipated level of service required in 2043 is reached.

Interventions for 2043

In order to deliver the 2043 ITSS and projected freight growth to 2043, this Route Study has identified a series of interventions that are described below. It is crucial that any such infrastructure interventions are part of an integrated package designed to respect and address the multiple constraints along the South Wales Main Line between Severn Tunnel Junction and Cardiff Central. [Tables 6.3, 6.4 and 6.5](#) detail these interventions.

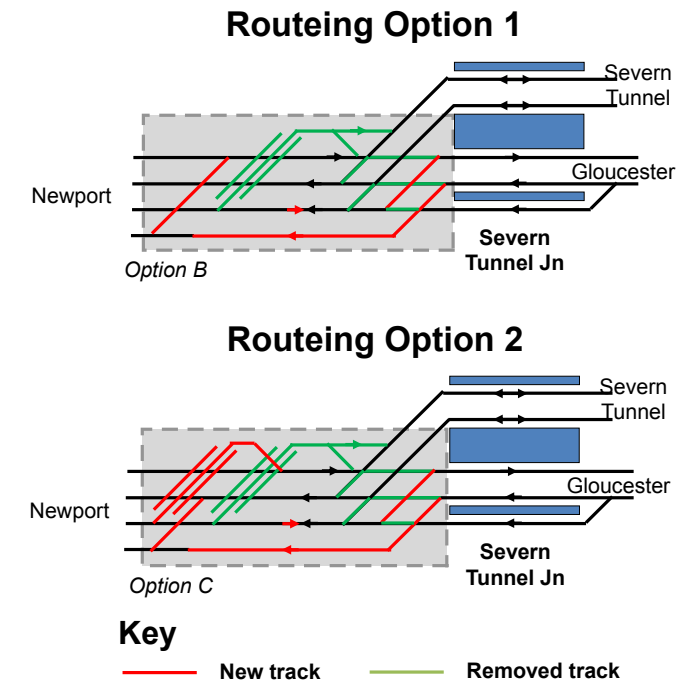

Table 6.3. Assessment of Option A: Reduced headways through the Severn Tunnel
<p>Summary of intervention: The current number of services able to use the Severn Tunnel is limited to an absolute maximum of nine per hour and direction. This could be improved through running services closer together.</p>
<p>Output assessment: The Severn Tunnel is currently incapable of accommodating the required level of service, due to the time required between successive trains, in each direction. The planning values are currently 5-7 minutes, depending on the mix of trains; however, with a reduction of values by 1 ½ minutes, the required ITSS could be accommodated. This reduction may be achievable through conventional signalling. However, timing of this particular intervention should be considered in the light of the evolving national deployment of ETCS, and the developing status of this technology. This technology is likely to provide a more cost-effective longer term solution with additional safety benefits. However, it should be noted that the flow of traffic through the Severn Tunnel is likely to be dictated by network constraints considered as part of the Western Route Study. These will need to be addressed before more services can be presented at the eastern end of the tunnel. This flow is also likely then to dictate constraints along the length of the South Wales Main Line to the west of the tunnel. Specifically, a greater flow of services through the tunnel may require larger scale interventions at Severn Tunnel Junction in order to be accommodated. It is considered that the optimum solution to enhance network capacity through the Severn Tunnel should be assessed as part of the future deployment of ETCS. Other considerations will also be necessary in terms of the safety regime for the Tunnel, in particular the plan for emergency evacuation of services in the case of any incident in the tunnel, especially if more than one train in any direction at any one time can operate in the tunnel.</p>
<p>Affordability assessment An estimate of the Anticipated Final Cost (AFC) is in progress and will be included in the final Route Study document.</p>

Table 6.4. Assessment of Option B: Redesign of Severn Tunnel Junction (Routeing Model 1)
<p>Summary of intervention: If Routeing Model 1 were to be adopted, in order to address the constraints along the whole length of the South Wales Main Line, it would drive the need for a flat junction and layout changes at Severn Tunnel Junction.</p>
<p>Output assessment: Under Routeing Model 1, there would be a requirement for a flat junction to permit freight services to move between the Relief Lines and the Tunnel Lines. This could replace Bishton Flyover, reducing maintenance requirements and improving line speeds through the section. In addition, there would be a need for related layout alterations at the west end of Severn Tunnel Junction station to separate Main Line and Relief Line flows. These are illustrated in Figure 6.6.</p>
<p>Affordability assessment An estimate of the Anticipated Final Cost (AFC) is in progress and will be included in the final Route Study document.</p>

Table 6.5. Assessment of Option C: Redesign of Severn Tunnel Junction (Routeing Model 2)
<p>Summary of intervention: If Routeing Model 1 were to be adopted, in order to address the constraints along the whole length of the South Wales Main Line, it would drive the need for a new grade separated junction, in conjunction with layout changes at Severn Tunnel Junction.</p>
<p>Output assessment: Under Routeing Model 2, there would be a need for a grade separated junction between the Up Relief and Up Main Lines, to permit freight to cross without interacting with Down Main Line traffic. This would replace Bishton flyover, which cannot provide the required routeing. In addition, there would be a need for related layout alterations at the east end of Severn Tunnel Junction station to separate Main Line and Relief Line flows. These are illustrated in Figure 6.6.</p>
<p>Affordability assessment An estimate of the Anticipated Final Cost (AFC) is in progress and will be included in the final Route Study document.</p>

Figure 6.6: Redesign of Severn Tunnel Junction



6.2.2.3 South Wales Main Line: Severn Tunnel Junction (exclusive) to Maindee Junctions (exclusive)

Overview

This section of line is four tracked, and accommodates the services outlined above. Freight destinations are located on the south side of the four track railway, and are served through connections with the Relief Lines.

Constraints in 2043

Since delivery of the 2043 ITSS and 2043 service specification are dependent on rethinking the current routeing of the South Wales Main Line, the constraints vary according to the routeing applied.

Under Routeing Model 1, there are no constraints other than in the Bishton area, covered in [Table 6.4](#).

Under Routeing Model 2, an increase in capacity will be required between Maindee Junctions with a new grade separated junction in the Bishton area (see [Table 6.5](#)).

Interventions for 2043

In order to deliver the 2043 ITSS and projected freight growth to 2043, this Route Study has identified the intervention that is described in [Table 6.6](#). It is crucial that any such infrastructure interventions are part of an integrated package designed to respect and address the multiple constraints along the South Wales Main Line between Severn Tunnel Junction and Cardiff Central.

The timing of this particular intervention should be considered in the light of the evolving national deployment of ETCS, and the developing status of this technology. ETCS has the potential to provide a more affordable and efficient solution in maximising the capacity available and delivering performance improvement along this part of the route.



Table 6.6. Assessment of Option A: Headway reduction on Relief Lines (Routeing Model 2)

Summary of intervention:

Under Routeing Model B, an increase in capacity on the Relief Lines will be required. This can be achieved through an improvement in the current signalling.

Output assessment:

Due to the number of Up services using the Relief Lines under this Routeing Model, coupled with the freight and passenger service speed differential, a headway improvement is required. This would be necessary between Maindee Junction, and the new crossing/flyover allowing transfer between Main and Relief Lines.

Affordability assessment

An estimate of the Anticipated Final Cost (AFC) is in progress and will be included in the final Route Study document.

6.2.2.4 Newport station, including Maindee and Gaer/Ebbw Junctions

Overview

Newport is an important mainline station, with all passenger services timetabled to stop. It is situated at a key point on the network, with Maindee Junctions – which give access to and from the Marches Lines – to the east, and Gaer and Ebbw Junctions – giving access to the Ebbw Vale Line – to the west.

As outlined in the introduction, above, the 2043 ITSS and 2043 freight forecast predict a significant increase in the number of services operating through this station. Currently, in addition to the services outlined in the introduction, there are a number of short distance freight workings between Alexandra Dock Junction and East Usk Junction.

Figure 6.7: Newport

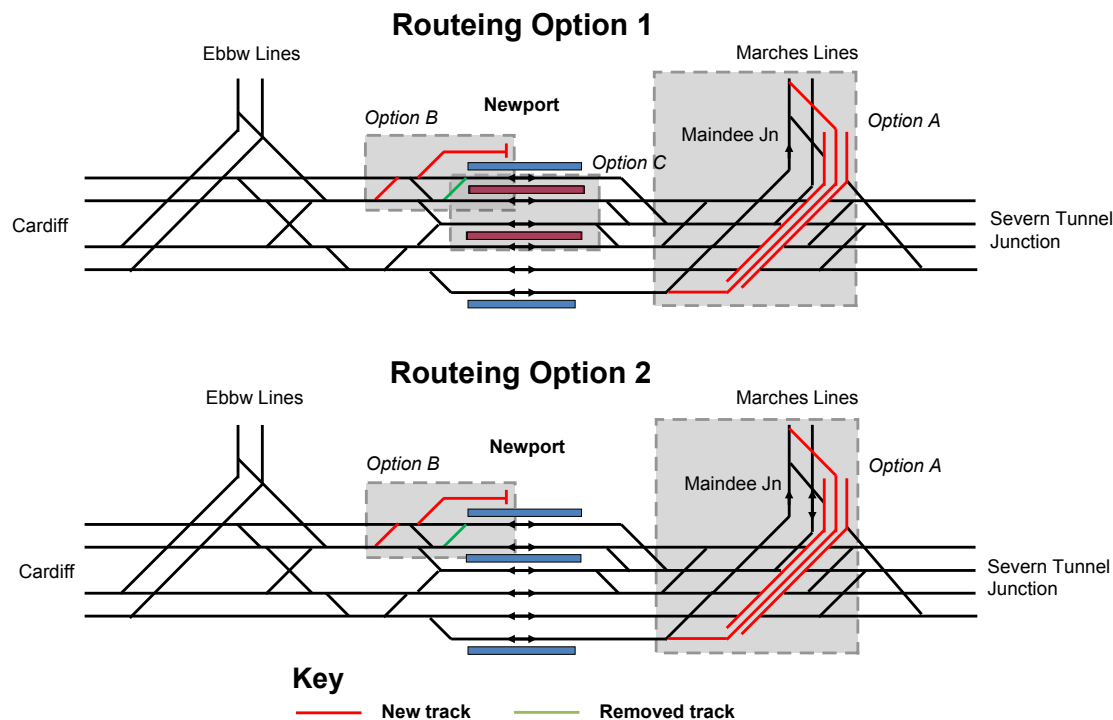

Constraints in 2043

Since delivery of the 2043 ITSS and 2043 service specification are dependent on rethinking the current routing of the South Wales Main Line, the constraints vary according to the routing applied. Newport is one of the most restricted points on this line, both in terms of the infrastructure available, and potential space to carry out any large-scale infrastructure interventions. Consequently, it drives the need for two routing models.

One of the key constraining points, which is treated differently by the two Routing Models, is Maindee West Junction. Based on the capabilities of existing technology, the timetabling of the 2043 ITSS and 2043 freight forecast would necessitate a grade separated junction to carry freight over the Main Lines, and onto the Relief Lines.

Under Routing Model 1, passenger services would not use this flyover, and would be routed along the Main Lines. This means that eleven through services would have to be routed through the Main Line platforms at Newport, with only two platforms – 3 and 4 – available for Main Line use. This number of services cannot be accommodated with these platforms, requiring an additional platform (see Table 6.9).

Alternatively, under Routing Model 2, Down Marches services would make use of the grade separated junction, with a corresponding number of Up services also transferred onto the Relief Lines. Consequently, Platforms 3 and 4 would be required to accommodate eight through services each, which is possible.

Neither Routing Model results in sufficient platform availability to accommodate the two terminating services per hour from the Ebbw Vale branch line. However, there may be the possibility of connecting these into other services, for instance into services terminating at Abergavenny. This would be dependent upon achievable timings at Newport, and therefore timetable and service development in the future.

Table 6.7 Assessment of Option A: Grade separation at Maindee West Junction

<p>Summary of intervention: Under the 2043 ITSS and 2043 freight forecast, a grade separated junction will be required to carry freight services over the Main Lines, and onto the Relief Lines. See Figure 6.7.</p>
<p>Output assessment: Regardless of the Routeing Option used, introduction of the 2043 ITSS and 2043 freight forecast will leave no opportunities for freight to cross over Maindee West Junction between the Marches Lines and the Relief Lines. Consequently, a single track grade separated bi-directional line, constructed alongside the south side of the River Usk viaduct, and swinging over the South Wales Main Line, is likely to be required for such freight services. Additionally, it could be utilised by passenger services leaving the Marches Line, in order to avoid the need for additional through platforms at Newport. The engineering feasibility of this intervention is currently being assessed, and will be reported upon in the final draft of the Route Study.</p>
<p>Affordability assessment An estimate of the Anticipated Final Cost (AFC) is in progress and will be included in the final Route Study document.</p>

Table 6.8 Assessment of Option B: Bay platform at Newport

<p>Summary of intervention: It is likely that a bay platform will be required to accommodate Ebbw Vale services turning round at Newport. See Figure 6.7.</p>
<p>Output assessment: Regardless of the Routeing Option used, there is insufficient time for services to turn round in either Platforms 3 or 4 at Newport, and where opportunities to use Platform 2 exist, there are unlikely to be opportunities to cross over to/from Gaer Junction. If services from the Ebbw Vale line terminate at Newport, it is likely that a bay platform will be required at the end of Platform 4. The engineering feasibility of this intervention is currently being assessed, and will be reported upon in the final draft of the Route Study.</p>
<p>Affordability assessment An estimate of the Anticipated Final Cost (AFC) is in progress and will be included in the final Route Study document.</p>

Table 6.9. Assessment of Option C: New/relocated through platforms (Routeing Model 1)

<p>Summary of intervention: Routeing Model A requires a third through platform on the Main Line side of the station. However, this will be difficult to achieve, due to the constraints of the current station location. See Figure 6.7.</p>
<p>Output assessment: Routeing Model A, in conjunction with the 2043 ITSS, sends 11 services per hour and direction along the Main Lines through Newport. Due to the physical constraints of the area, which limit line speeds, sighting distances, and platform lengths, Newport can, even in the best case, accommodate only ten trains per hour at each platform. The frequency with which the Relief Lines are used means that there are no opportunities to cross over at Newport to use the Relief Line platforms. Consequently, at least one new through line platform will be required on the Main Line side of the station. The engineering feasibility of this intervention is currently being assessed, and will be reported upon in the final draft of the Route Study.</p>
<p>Affordability assessment An estimate of the Anticipated Final Cost (AFC) is in progress and will be included in the final Route Study document.</p>

Interventions for 2043

In order to deliver the 2043 ITSS and projected freight growth to 2043, this Route Study has identified the intervention that is described below. It is crucial that any such infrastructure interventions are part of an integrated package designed to respect and address the multiple constraints along the South Wales Main Line between Severn Tunnel Junction and Cardiff Central. The infrastructure interventions in this area are detailed in [Tables 6.7, 6.8 and 6.9](#), and [Figure 6.7](#).

Table 6.10. Assessment of Option A: Headway reduction (Routeing Models 1 and 2)**Summary of intervention:**

Under either Routeing Model, an increase in capacity will be required, on the Main Lines under Model 1, and on both Main and Relief Lines under Model 2. This can be achieved through an improvement in the current signalling.

Output assessment:

Under Model 1, the number of services using the Main Lines between Ebbw Junction and Cardiff Central (13 tph) necessitates a headway improvement of one minute.

Under Model 2, the number of services using the Relief Lines between Ebbw Junction and Cardiff Central (11 tph), coupled with the freight and passenger service speed differential, necessitates a headway improvement of one minute on the Relief Lines as well as the Main Lines. This can be achieved through adding to and re-spacing the existing signalling. However, the timing of this particular intervention should be considered in the light of the evolving national deployment of ETCS, and the developing status of this technology. ETCS has the potential to provide a more affordable and efficient solution in maximising the capacity available and delivering performance improvement along this part of the route.

Affordability assessment

An estimate of the Anticipated Final Cost (AFC) is in progress and will be included in the final Route Study document.

6.2.2.5 Ebbw Vale Branch Line**Overview**

The Ebbw Vale branch is a passenger line, terminating at Ebbw Vale Town, and serving a number of local stations. While it currently accommodates one train per hour, higher-than-anticipated demand since reopening to passenger services means that a scheme is currently being developed which passively provides the capacity for three trains per hour as far as Llanhilleth station.

6.2.2.6 South Wales Main Line: Ebbw Junction (exclusive) to Cardiff Central (exclusive)**Overview**

This section of track is four tracked, and accommodates the services outlined above. Freight destinations are located to the south of this section of the South Wales Main Line, and are served through connections with the Relief Lines.

Constraints in 2043

Since delivery of the 2043 ITSS is dependent on rethinking the current routeing of the South Wales Main Line, the constraints vary according to the routeing applied.

Under Routeing Model 1, an increase in capacity will be required between Newport and Cardiff Central on the Main Lines only.

Under Routeing Model 2, an increase in capacity will be required between Newport and Cardiff Central on both the Main and Relief Lines.

Making best use of baseline infrastructure, up to 2043 specification

As outlined above, depending on the routeing strategy adopted, this section may be able to accommodate the services required under the 2043 ITSS and 2043 freight forecast.

Interventions for 2043

In order to deliver the 2043 ITSS and projected freight growth to 2043, this Route Study has identified the intervention that is described below.

It is crucial that any such infrastructure interventions are part of an integrated package designed to respect and address the multiple constraints along the South Wales Main Line between Severn Tunnel Junction and Cardiff Central.

Details of the required infrastructure interventions is detailed in [Table 6.10](#).

6.2.2.7 Cardiff Central Station**Overview**

Cardiff Central is the busiest station in Wales, and a key stop for all passenger services on both the South Wales Main Line and the Valley Lines. Many services on the Main Line side of the station terminate at Cardiff in the southern pair of platforms, and have to move across the face of the station in order to depart from the northern platforms. Due to these moves, which consume substantial track capacity, and due to current platform utilisation, which requires all Main Line services arriving at Cardiff Central to cross the Relief Lines, the station is a significant constraint to increasing services beyond the baseline level. However, the 2043 ITSS and 2043 freight forecast predict a substantial increase in the number of services through this station.

Constraints in 2043

Altering the routeing into and out of Cardiff Central is crucial to freeing up sufficient capacity, at the station, to accommodate the services envisaged under the 2043 ITSS and 2043 freight forecast. However, unlike other parts of the South Wales Main Line, the points of constraint remain the same, regardless of which Routeing Model is used.

On the Main Line side of the station, there will be limited platform availability. Successful operation of the station will require significant changes in how services are received from the east. In order to accommodate the required services, Platform 0 will need to be primarily used for eastbound arrivals and departures, Platform 2 for westbound arrivals and departures, and Platform 1 in both directions, as required. However, Platform 0 is currently unable to accommodate Long Distance services, due to both platform length and accessibility.

Figure 6.8: Cardiff Central

Cardiff Central baseline layout

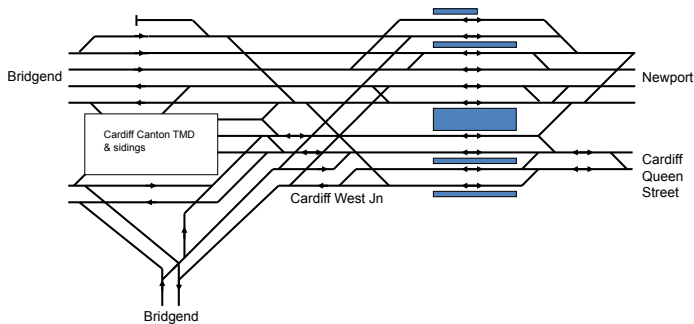

Layout required for both routeing options

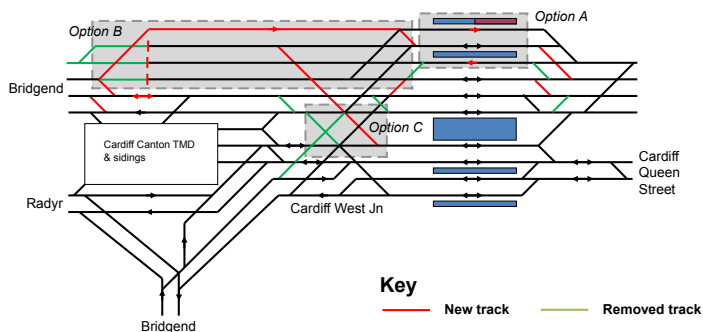

A key element of the proposed Routeing Models is that they remove the need for services turning round at Cardiff to cross the station layout in between arrival and departure, by splitting the station into Main Line and Relief Line sides. However, this necessitates stabling the majority of passenger services which turn round at Cardiff on the northern, Main Line side of the station. There is currently insufficient space here to hold all the services required under the 2043 ITSS.

The south, Relief Line side of the station presents fewer constraints, since it is currently used more intensively than would be required in the future. However, currently services departing Platform 4 for either the Main Lines or stable areas at Cardiff Canton have to interact with Valley Line services over Cardiff West Junction. The opportunities to cross Cardiff West Junction will decrease in the future, with the introduction of a more intensive Valley Lines timetable, and this is likely to prove a constraint to delivery of the 2043 ITSS and a critical constraint upon performance on both the South Wales Main Line and the Valley Lines.

Interventions for 2043

In order to deliver the 2043 ITSS and projected freight growth to 2043, this Route Study has identified the interventions that are described below. It is crucial that any such infrastructure interventions are part of an integrated package designed to respect and address the multiple constraints along the South Wales Main Line between Severn Tunnel Junction and Cardiff Central.

6.2.2.8 South Wales Main Line: Cardiff Central to Swansea Overview

This lengthy section of line is double tracked throughout, with freight passing loops. Currently, it accommodates a limited mix of Long Distance High Speed, regional and local passenger services alongside freight trains. The line serves a number of stations of varying sizes, with particularly large stations including Bridgend, which provides links to the Vale of Glamorgan line, and Maesteg branch line, and Port Talbot Parkway and Neath.

Peak demand into Swansea from the east is forecast to be close to capacity by 2043. However additional services identified in the 2043 ITSS will accommodate this increased demand.

Constraints in 2043

Theoretically, there are no constraints to delivery of the 2043 ITSS and 2043 freight forecast. These come close to utilising the full capacity of the line, with an appropriate performance buffer, but the re-timings dictated by the South Wales Main Line capacity east of Cardiff do permit the running of the required number and mix of services west of Cardiff. However, this does depend on looping freight services, and practical timetable development may demand extension and relocation of loops.

Interventions for 2043

Practical timetable development may demand extension and relocation of loops, for the purposes of timetable flexibility or establishing a performance buffer. However, this will if necessary be timetable dependent; no such infrastructure interventions are required on a theoretical basis.

6.2.2.9 Maesteg branch line

The Maesteg branch is a passenger line, single tracked throughout, serving a number of local stations. While it currently accommodates one train per hour, a scheme is currently being developed to provide the capacity for two trains per hour and direction, as required under the 2043 ITSS.

6.2.2.10 Swansea Station

While the layout at and on the approaches to Swansea offers no constraint to the delivery of the 2043 ITSS, the Port Talbot West re-signalling works programmed for delivery in CP5 has taken the opportunity to provide signalling to enable passenger services to either depart or arrive from both the west (Llanelli) and east (Port Talbot) directions simultaneously. This will allow for improved performance and timetable flexibility, particularly in the future should additional passenger services be specified.

Table 6.11. Assessment of Option A: Extension of Platform 0**Summary of intervention:**

In order to permit platforming of all the required services on the Main Line side of Cardiff Central, it will be necessary to extend Platform 0 so that it is a full-length platform.

Output assessment:

Regardless of the Routeing Model chosen, it will be necessary to extend Platform 0 so that there are three full platforms capable of taking all types of passenger train on the north (Main Line) side of the station. This will then become the main platform for eastbound services.

Under Routeing Model A, platform usage on this side of the station will still be at a considerable level, and may depend on platform sharing for regional and local services. Under Routeing Model B, platform usage will be lower, due to the transfer of services onto the Relief Lines, and all services may be able to be accommodated without platform sharing. In both these instances, successful operation is dependent on sufficient stabling sidings being available on the north side of the station, in order to remove the need for terminating services to cross the station while turning round.

This intervention is currently being developed as part of the Cardiff Central Station enhancement scheme.

See [Figure 6.8](#).

Affordability assessment

This will be assessed as part of the overall scheme to enhance Cardiff Central station.

Table 6.12. Assessment of Option B: Centre turnback sidings**Summary of intervention:**

The change in routeing means that services from the Main Lines utilise the northern set of platforms only. This, coupled with the significantly greater intensity in services, means that more stabling sidings will be required on the northern side of the station.

Output assessment:

Long distance services take some considerable time to be turned round (this process usually consisting of a crew change, clean, and where necessary refuel, which provides a performance buffer). This is not usually possible while remaining at the platform at Cardiff Central, even today, due to a lack of platform availability, so services shunt out of the west end of the station to stabling areas north and south of the main running lines. The current stabling facilities situated on the north side of the running lines will not be able to accommodate the increase in services to meet the 2043 ITSS, especially when this is coupled with the change in routeing which will lead to heavier use of Platforms 0, 1 and 2.

In order to address this, and to reduce the number of conflicting moves as far as possible, it is proposed that the north-west end of the station is reconfigured, with the eastbound Main Line being the northernmost line, and 2-3 turn back sidings in the centre of the layout, providing easy access out of and into Platforms 0, 1 and 2. This will also require appropriate associated switches and crossings, but may permit rationalisation of other parts of the layout in this area.

See [Figure 6.8](#).

Affordability assessment

An estimate of the Anticipated Final Cost (AFC) is in progress and will be included in the final Route Study document.

Table 6.13. Assessment of Option C: Separation of Main Line and Valley Line flows**Summary of intervention:**

Services departing Platform 4 currently conflict with Valley Line services approaching Platform 6 from the City Lines. This is likely to require addressing.

Output assessment:

Main Line services departing Platform 4 westbound conflict with eastbound Valley Lines services approaching Platform 6 from the City Lines. These traffic flows are likely to require separating, to increase the available opportunities to clear Platform 4, and reduce performance risk to Valley Line services.

Any intervention should be considered in the context of options for the junction as a whole, since addressing the lack of stabling facilities on the north side of the station, and the constraints that Cardiff West Junction and Radyr Branch Junction present to Valley Lines services, is likely to permit some rationalisation of the junction. However, fundamentally the flows can be separated through installation of a new set of switches, permitting access from Platform 4 onto the running lines without crossing Valley Lines flows.

This option is currently being developed, and will be reported upon in the final draft of this document.

See [Figure 6.8](#).

Affordability assessment

An estimate of the Anticipated Final Cost (AFC) is in progress and will be included in the final Route Study document.

6.2.2.11 Conclusions Constraints Summary

The South Wales Main Line has been shown to have several constraining areas which will need to be addressed in order to deliver the 2043 ITSS and 2043 freight forecast. It is crucial that these are treated and addressed as an integrated whole: specific interventions should be developed with the long-term aim of altering the routeing principles of the South Wales Main Line, thereby unlocking the latent capacity potential provided by the current infrastructure. [Table 6.14](#) summarises the constraints along this route which are likely to require such interventions.

The suggested interventions, which are based on current technology, vary according to the Routeing Model chosen. These different demands made by the two models are summarised in [Figure 6.9](#).

These interventions are based on existing technology; developing technology may present alternative solutions.

Digital Railway

Network Rail is currently developing the concept of the Digital Railway. The deployment of ETCS, and the anticipated development of enhanced levels of ETCS in the future, is likely to have a significant impact on the South Wales Main Line, potentially removing or reducing the need for some of the major civil engineering interventions – and associated significant capital costs – proposed. At this stage, it is not possible to assess with any accuracy the likely impact of this technology, but any interventions in the future should be qualified against technological developments.

There are a number of areas where ETCS, as currently understood, is very likely to be able to provide enhanced capabilities and capacity. [Table 6.15](#) gives a high-level indication of the Planning values around identified constraints that ETCS would need to improve, in order to remove or limit the need for capital works.

Depending on the precise capabilities lent by ETCS development, there is, as outlined above, the potential for it to address a significant number of the capacity constraints on the South Wales Main Line.

However, in the shorter term, there is also the possibility of making best use of existing capacity, with no or limited infrastructure interventions.

Making best use of baseline infrastructure, up to 2043 specification

Along the South Wales Main Line between Severn Tunnel Junction and Cardiff, any significant increase in service beyond the levels timetabled today is likely to require utilisation of this line as a four track railway. This would be in line with – for example – the use of the southern end of the West Coast Main Line, with Long Distance High Speed and regional passenger services on one set of lines, and local and regional passenger services running alongside freight trains on the other. However, services using the Relief Lines are currently likely to incur a journey time penalty, due to there being a substantial difference between the permitted line speeds on the Main and Relief lines. This currently limits the practicality of running passenger services along the Relief Lines.

Table 6.14 SWML Constraints

Constraint	Severity*	Routeing Option 1 intervention(s)	Routeing Option 2 intervention(s)
Severn Tunnel.	Secondary	Reduction of headways.	Reduction of headways.
Severn Tunnel Junction.	Secondary	Redesign of Severn Tunnel Junction (no flyover required).	Redesign of Severn Tunnel Junction (flyover required).
Severn Tunnel Junction-Newport.	Secondary	n/a.	Headway reduction on Relief Lines.
Newport.	Primary	Grade separation at Maindee West Junction.	Grade separation at Maindee West Junction.
		Bay platform.	Bay platform.
		New/relocated through platforms.	n/a.
Newport-Cardiff.	Primary	Reduction of headways.	Reduction of headways.
Cardiff Central.	Primary	Extension of Platform 0.	Extension of Platform 0.
		Centre turnback sidings.	Centre turnback sidings.
		Separation of Main Line and Valley Line flows.	Separation of Main Line and Valley Line flows.

*Primary constraints are those which most immediately limit increases in service specification beyond the 2019 baseline assumption. Secondary constraints will become a significant constraint once the primary constraints are addressed.

Figure 6.9: SWML options by Routing Model

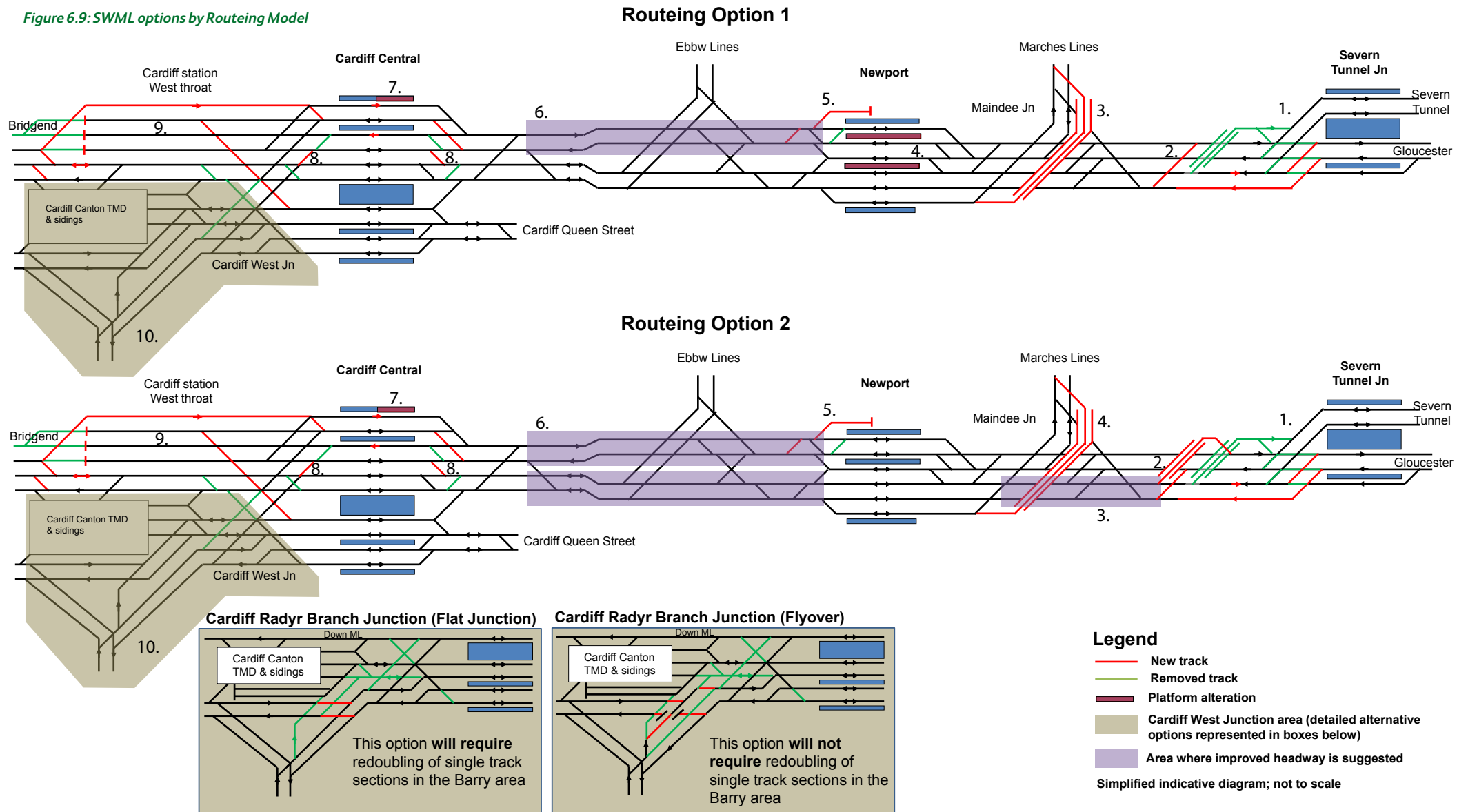

It also limits the practical use of Platform 1 at Newport; this asset is currently under-utilised, due to the capacity consumed by crossing over the Relief Lines into and out of this platform. There are also constraints to turning round services from Ebbw Vale at Newport which might be addressed by moving some passenger services onto the Relief Lines, and operating them through Platforms 1 and 2.

The current use of the South Wales Main Line also leads to a high number of conflicting crossing moves outside Cardiff Central, with all westbound passenger services crossing the Relief Lines in order to access Platforms 3 and 4, and all terminating services currently crossing the layout while empty in order to depart from Platforms 0, 1 or 2. These conflicting moves might be able to be reduced through use of Platform 2 for westbound services, and some use of the Relief Lines by passenger services, potentially increasing the number of paths available through the station.

Ultimately, the infrastructure is capable of accommodating a greater level of service, but only with a change in routeing strategy.

New stations

As part of the longer-term vision, stops at new stations, built on the Relief Lines, might need to be accommodated within the Routeing Models developed. Certain services are theoretically capable of calling at these stations, with the precise destinations of these services dependent on timetable development, and the manner in which the identified constraints are addressed. However, it is likely that, under the level of service identified in the 2043 ITSS and 2043 freight forecast, the choice of destinations east to and from such stations will be limited.

This is because, under either Routeing Model developed in this study, the services using the Relief Lines are likely to be those to/from destinations accessed via Gloucester. Providing consistent links in both directions with services travelling in the London/Bristol direction, or along the Marches Line, will require greater numbers of crossing moves across the key congested junctions. This is not possible while maintaining the total required level of service, and is likely, with current technology, to necessitate some form of future intervention.

Table 6.15: Planning headways potentially required to accommodate 2043 ITSS

Area	Current Planning values	Possible required Planning values	Notes
Severn Tunnel.	Four minute headway.	Three minute headway	Improved headway could only be used if constraints addressed elsewhere.
Severn Tunnel Junction.	Variable .	Some improvement	Likely improvement required is c. one minute reduction in values for all services.
Severn Tunnel Junction - Newport.	Relief Lines: five minute headway.	Four minute headway	Four minute headway currently on Main Lines through this section.
Maindee Junctions.	Variable .	Significant improvement	Likely improvement required is >one minute reduction in values for all services.
Newport.	Two minute dwell, three minute reoccupation.	Two minute reoccupation	Reduction in platform reoccupation value by at least one minute likely to be extremely beneficial.
Ebbw/Gaer Junctions.	Usually three minutes before and after conflicting move	Some improvement beneficial	Improvement would be beneficial for performance, but not required subject to timetable development.
Ebbw Junction - Cardiff.	Four minutes, Relief and Main Lines	Three minutes	Improvements on Main Lines required regardless of Routeing Model.
Cardiff Central.	Three minute dwell, three minute reoccupation	Two minute reoccupation	Reduction in reoccupation values may permit Routeing Option 1 to be operated without platform sharing. Beneficial for performance.
Cardiff West Junction.	Variable	Some improvement beneficial	Improvement would be beneficial for performance, but not required subject to timetable development.
Cardiff-Swansea.	Four/five minute headway	Some improvement beneficial	Improvement would be beneficial for performance, but not required subject to timetable development.
Swansea station.	Six minute platform reoccupation	Some improvement beneficial	Improvement would be beneficial for performance, but not required subject to timetable development.

Figure 6.10: South West Wales

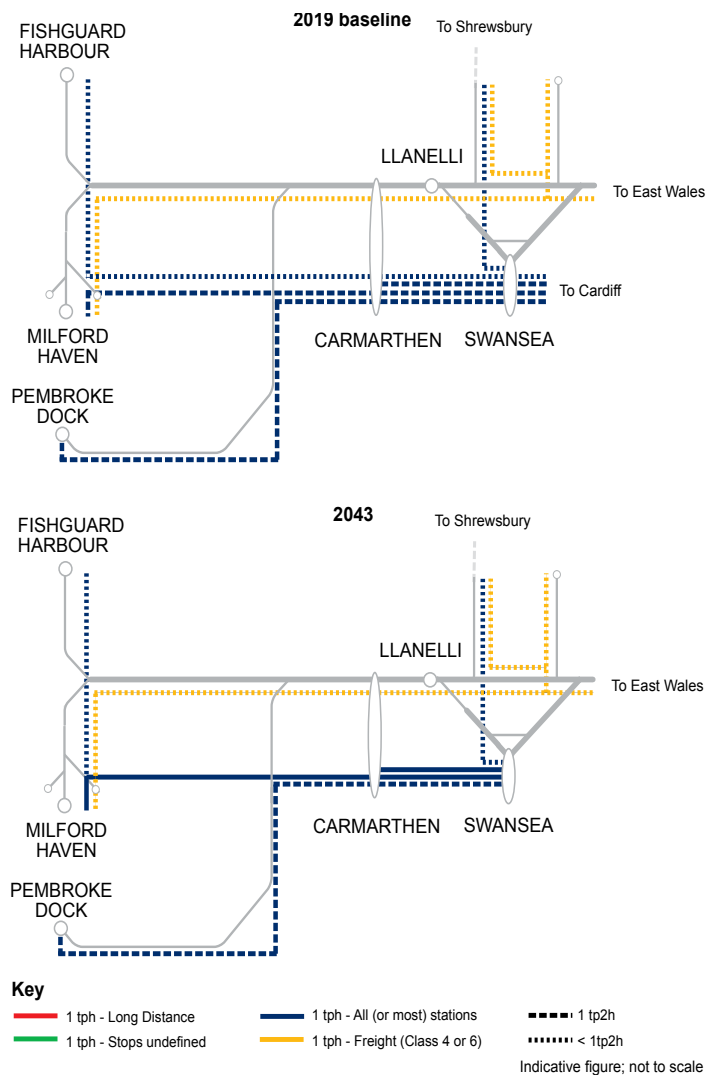

6.2.3 South West Wales

Overview

This route accommodates local services on a fairly frequent (1-2 trains per hour) basis between Swansea and Carmarthen with less frequent services then extended to Fishguard (with ferry connections to Ireland), Milford Haven and Pembroke Dock. There are some freight flows along the route, primarily serving facilities at Llanelli and Milford Haven.

In the longer term, the 2043 ITSS predict an increase in passenger services. This is reflected in Figure 6.10.

Constraints in 2043

The 2043 ITSS provides for additional services to Milford Haven, with potentially some services splitting/adjoining at Clarbeston Road. This would also afford an increase in frequency on the busiest section of the route between Carmarthen and Swansea. In addition Section 5.1.6 outlines the three-year trial operation of additional peak services on the Heart of Wales line which joins this route near Llanelli. All of these additional services can be accommodated on the existing network infrastructure.

6.2.4 Valley Lines

Overview

The Valley Lines network provides for commuting, business and leisure flows into Cardiff city centre. Enhancements delivered as part of resignalling works in the Cardiff area will enable up to 16 trains per hour to operate through the central Cardiff core between Cardiff Queen Street and Cardiff Central during peak hours.

There are a number of single line sections and junctions which would require further intervention in order to enable more flexibility and more resilience in delivery of future all day timetable requirements. Within the planning horizon of this Route Study these are described as network constraints.

The potential future development of a multi-modal 'Metro' transport system also highlights the need to consider holistically, the transport needs for the Cardiff metropolitan area, and the need to assess future transport interventions in a co-ordinated manner that deliver future affordability and best value for money.

The following section sets out the network constraints for which a series of high level options will be presented in the final published Welsh Route Study. This will enable the feasibility and costs of these options to be assessed in line with the wider integrated metro transport options to determine overall best value of future required outputs for the network.

Constraints in 2043

Table 6.16 details the key long term constraints on the Valley Lines Network. These would need addressing to optimise delivery of an all day timetable that delivers 16 trains per hour through the central Cardiff core.

Interventions required

In order to deliver the 2043 ITSS and projected freight growth to 2043, this Route Study has identified the series of interventions that are outlined in Table 6.16 alongside the constraints.

As detailed above, the final Welsh Route Study will report on the findings of engineering feasibility and cost work associated with these options. It is suggested that this should help inform future development of the network in line with other developments.

Network Rail will continue to support the development of the optimum integrated transport network options that deliver overall affordability and value for money and which identify the roles that heavy rail modes and light rail modes are best placed to address future capacity requirements and overcome existing and future anticipated network constraints.

Additionally, the future continued development and evolution of ETCS might also address more affordable solutions to increase network capacity in the medium to longer term and this will continue to be reviewed through the strategic planning process.

Table 6.16 Constraints and interventions required on the Valley Lines Network to meet longer term strategic requirements

Area	Constraint	Intervention
Cardiff West Junction.	Point of conflict between Cardiff-bound services from the Bridgend direction, and Valleys-bound services moving out of Cardiff onto the City Lines. Inherent in flat junction, but exacerbated by current layout.	Simplified flat junction, with targeted redoubling of single branch lines to reduce timing constraints OR Grade separated junction, removing constraint and separating traffic flows.
Cardiff Central.	Platforms 6 and 8 cannot accommodate all services in either direction. Therefore Platform 7 will be required to be used in both directions, to allow some services to be accommodated. Constraints at Cardiff West Junction and Cardiff Queen Street mean that the timetable must make use of 100% of the capacity of Platform 7, which presents a significant performance risk.	Installation of infrastructure, or rolling stock strategy, to permit platform sharing.
Cardiff Queen Street.	The physical constraints of the station's location limit the ability of current signalling technology, which restricts services in both directions from approaching the platforms at optimum timings or a flexible pattern. This has to be addressed through extending the station dwell times of services, with a consequent journey time impact, and by fixing times of arrival and departure at the station at sub-optimal intervals, given other network constraints.	Extend platform loops – this is likely to require significant infrastructure works. Consider opportunity to provide additional bridge span over Newport Road to the north of the station to improve layout flexibility.
Radyr-Pontypridd.	Current signalling does not permit the operation of freight trains alongside the full passenger specification. The operation of freight services requires passenger services to be removed from the timetable.	Improvement of signalling headway, through signalling remodelling/enhancement scheme.
Aberdare Line.	Single line track, coupled with the length and position of current loops, does not permit the operation of freight trains alongside the full passenger specification. The operation of freight services requires passenger services to be removed from the timetable.	Extension of double track north from Abercynon to Mountain Ash.

6.2.5 Newport to Crewe (via Shrewsbury)

6.2.5.1 Newport Maindee Junctions – Shrewsbury Abbey Foregate Junction

Overview

This route provides a mixture of local and long distance passenger traffic and heavy freight traffic.

In the longer-term, the 2043 ITSS and 2043 freight growth forecast require the current number of passenger and freight services to increase. This is reflected in Figure 6.11.

Constraints in 2043

The timings of trains onto and off this part of this route are heavily dictated by constraints at other major network nodes, such as Newport on the South Wales Main Line, and Crewe and Birmingham New Street.

Additionally, the route has some significant gradients that severely restrict the maximum speed of freight services compared to passenger services, which has an impact on overall route capacity.

Other route constraints include long signalling sections that limit available capacity and freight loops of limited lengths at key locations.

It is not possible to accommodate the 2043 ITSS and 2043 freight growth, because of these constraints, without either considering a trade-off in future service specification or investment in additional infrastructure. The following sections consider these in more detail.

Making best use of current infrastructure, up to 2043 specification

In practice, the constraints identified on other parts of the network prohibit the accommodation of the 2043 ITSS on this route. Therefore, while there may be the capability for shorter distance passenger services to utilise parts of the line – for instance at the north and south ends, and around Hereford – it is unlikely that today’s number of long distance freight and passenger paths can be substantially increased.

Therefore the ability to operate increased levels of service, both passenger and freight, should be considered in the light of future changes to service specifications both on this route, and on other routes that interact closely with this part of the network.

Interventions for 2043

In order to deliver the 2043 ITSS and project freight growth to 2043, this Route Study has identified a series of interventions that are described in Tables 6.17, 6.18 and 6.19.

The timing of the intervention detailed in Table 6.17 should be considered in the light of the evolving national deployment of ETCS, and the developing status of this technology. ETCS has the potential to provide a more affordable and efficient solution in maximising the capacity available and delivering performance improvement along this part of the route.

Figure 6.11: Newport to Shrewsbury

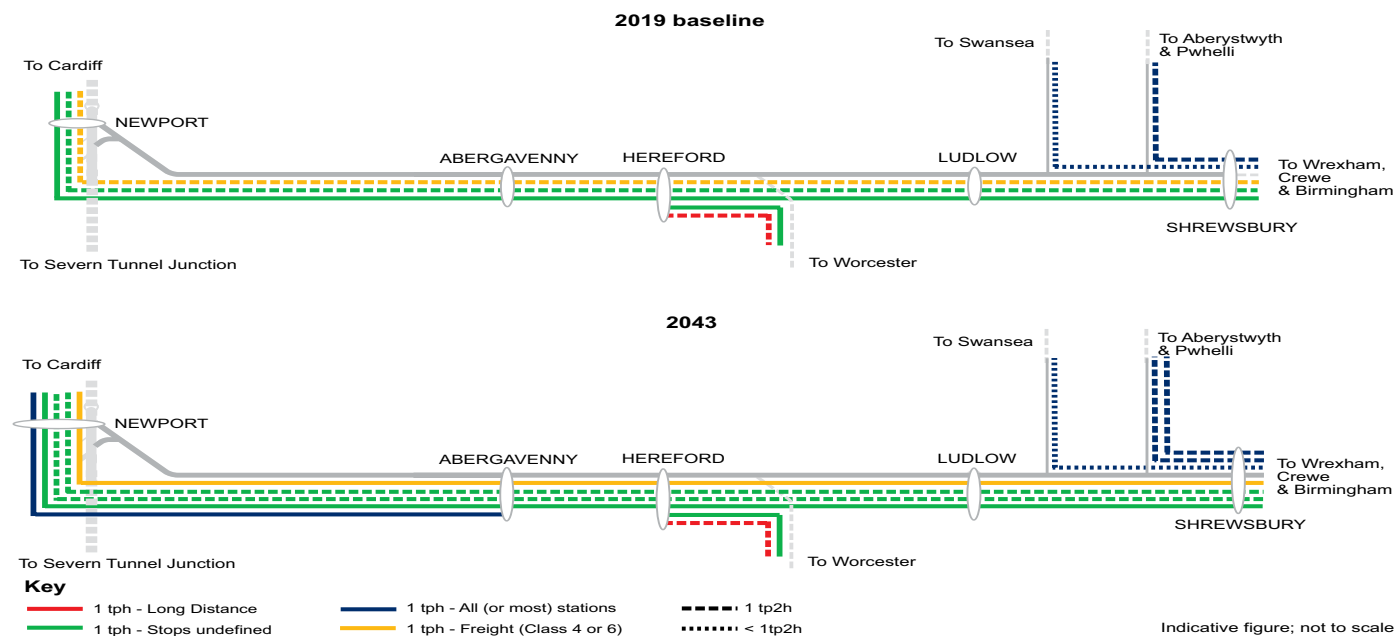

Table 6.17. Assessment of Option A: Additional signalling sections**Summary of intervention:**

A number of long signalling (Absolute Block) sections restrict the line from accommodating the 2043 freight and passenger service levels and speed mix. Therefore, the splitting of block sections at four locations will be required.

Output assessment:

Additional intermediate signals at:

- Dorrington-Sutton Bridge Junction (both directions)
- Moreton-Shelwick Junction (Down)
- Hereford-Tram Inn (Down)
- Abergavenny-Nantyderry (Down).

This will theoretically permit the timing of all required services, in both directions. However, further interventions (see Option b) are likely to be required to allow sufficient timetabling and performance flexibility in the Up direction, towards Shrewsbury.

Affordability assessment

An estimate of the Anticipated Final Cost (AFC) is in progress and will be included in the final Route Study document.

Table 6.18. Assessment of Option B: New Up Freight loop, and freight loop lengthening**Summary of intervention:**

A new freight loop capable of holding 2400 tonne freight trains is required in the Up direction (towards Hereford) between Maidee North Junction and Pontrilas. In addition, most of the current freight loops will require lengthening if heavier, longer freight trains are to be timetabled regularly.

Output assessment:

2400 tonne freight trains cannot be held at the current Panteg Up freight loop, due to the adverse gradient. The freight running times from Maidee West Junction to the next loop, at Pontrilas, are the ruling constraint on this route, requiring perfect timings when coupled with the required passenger speed differentials. Consequently, a new freight loop will be required between Maidee West Junction and Pontrilas.

In addition, most of the freight loops on the route are substantially shorter than the limit currently applied on the network; a number of these will be likely to require lengthening if 2400 tonne freight services are timed on an hourly basis. Possible candidates for lengthening are:

- Panteg Down
- Pontrilas (Up)
- Hereford Down
- Woofferton (Up)
- Craven Arms (Down)
- Sutton Bridge (Up).

Affordability assessment

An estimate of the Anticipated Final Cost (AFC) is in progress and will be included in the final Route Study document.

Table 6.19. Assessment of Option C: Turnback facility at Abergavenny**Summary of intervention:**

Provision of a bay at Abergavenny, in order to turn round a local service from Cardiff Central.

Output assessment:

Given the envisaged mix and intensity of passenger and freight services to 2043, it may be impossible to turn round the local service to and from Cardiff at Abergavenny on the current infrastructure. Consequently, a bay platform is likely to be required should this service be specified in the future.

Affordability assessment

An estimate of the Anticipated Final Cost (AFC) is in progress and will be included in the final Route Study document.

6.2.5.2 .Shrewsbury station

Overview

Shrewsbury acts as an important hub station at the centre of routes radiating in five directions. This location and function, and the number of different but interlinked flows which pass through and/or start/terminate at the station, act as a constraint on capacity availability.

In the longer term, the 2043 ITSS and 2043 freight growth forecast require the current number of passenger and freight services to increase. This is reflected in Figure 6.12.

Constraints in 2043

As on other parts of the route between Newport and Crewe, the timings of trains through Shrewsbury will generally be dictated by constraints at other network nodes, such as at Birmingham New Street, Crewe and Chester. Consequently, it is likely that many services will require longer-than-average stops at Shrewsbury, in order to meet their timings at these other key constrained points elsewhere on the network.

Additionally, the routing of future services contained within the 2043 ITSS through Shrewsbury is significant in that it features a number of passenger trains which, from the same point of origin, serve different destinations across alternate hours. The consequence of this routing is that most passenger services are affected by multiple network constraints, posing a risk to performance, and due to these constraints, are generally likely to arrive at Shrewsbury at a similar point in the hour.

As a result, Shrewsbury is unlikely to have the required amount of platform space to accommodate the full 2043 ITSS. It will, therefore, probably require a trade-off in service structure, and/or infrastructure investment.

Making best use of current infrastructure, up to 2043

This will be dictated by constraints at other network nodes. Currently, these mean that many of today's passenger services arrive in succession, with limited platform availability in times of perturbation. It is likely that only a limited number of additional services could be timetabled through Shrewsbury.

A number of services, since they serve different routes across alternate hours, have constrained timings due to multiple constraints on different parts of the network. A service trade-off might be to reduce the number of these variable routes, thereby reducing the number of constraints which these services must respect. This could add the flexibility to better stagger arrivals and departures at Shrewsbury.

However, there is still likely to be a requirement to timetable certain services at close intervals, in order to maximise journey opportunities and limit generalised journey times. This would limit the possible performance benefits of this strategy. Additionally, it could increase the number of services requiring to turn back at Shrewsbury, itself limiting platform capacity.

In seeking to deliver the optimum service choices in the future, trade-offs between through services off routes such as the Cambrian Main line should be considered where these might reasonably use scarce capacity for other longer distant services.

Figure 6.12: Shrewsbury services

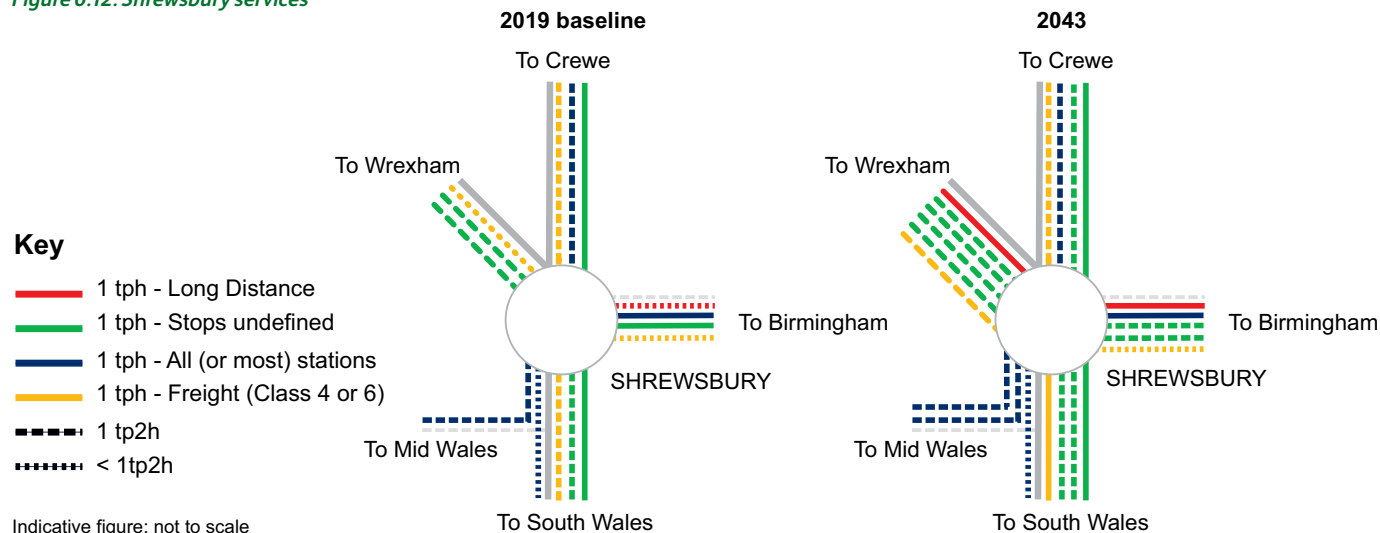

In seeking to provide additional services on a north-south axis in the longer term, the use of Shrewsbury station as a hub station should be considered with the ability to regularly connect into other services, improving overall generalised journey times.

Interventions for 2043

In order to deliver the 2043 ITSS and projected freight growth to 2043, this Route Study has identified a series of interventions that are described in [Tables 6.20 and 6.21](#).

Figure 6.13: Shrewsbury station

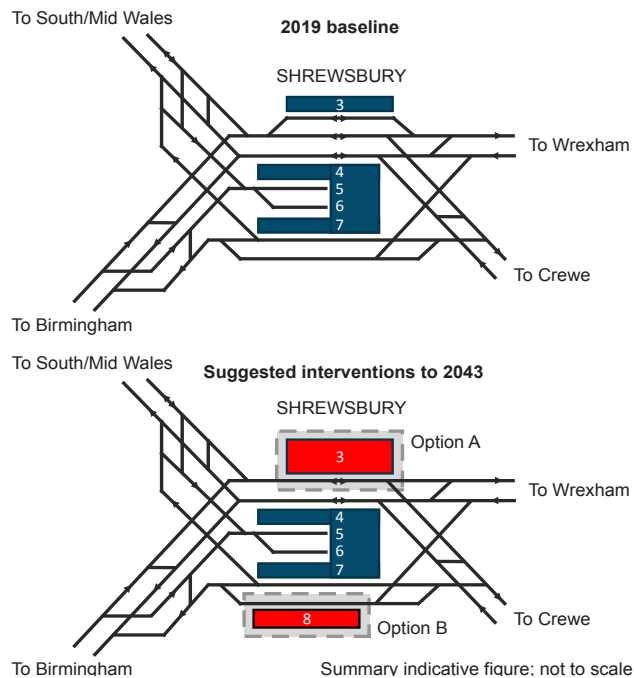

Table 6.20. Assessment of Option A: Extension of Platform 3

Summary of intervention:
Platform 3 will increasingly be used to accommodate the full range and number of anticipated services. Extending it out to the through lines will facilitate access to the Crewe lines.

Output assessment:
Platform 3 is required to accommodate the 2043 ITSS, holding the majority of northbound Wrexham traffic as well as some services turning round. Extending it out to the current through lines, which are lightly used, would permit access to the Crewe lines, potentially permitting the direction of traffic through all platforms to be standardised in normal operation, and leaving one of the existing platforms free to permit turnrounds from the north.

See [Figure 6.13](#).

Affordability assessment
An estimate of the Anticipated Final Cost (AFC) is in progress and will be included in the final Route Study document.

Table 6.21. Assessment of Option B: Additional bay or through platform

Summary of intervention:
A north-facing bay, or additional through platform, is likely to be required if long distance high speed services from London are turned back at Shrewsbury.

Output assessment:
If long distance high speed services are turned round at Shrewsbury, rather than extended to Wrexham (where infrastructure work would also be needed), the time required to turn round such services is likely to drive the need for an additional platform. Possible space has been identified on the north-east side of the station. A bay platform could be used to turn round services to and from the north; a through platform would add flexibility to the operation of the whole station.

Affordability assessment
An estimate of the Anticipated Final Cost (AFC) is in progress and will be included in the final Route Study document.

Figure 6.14: Shrewsbury to Crewe

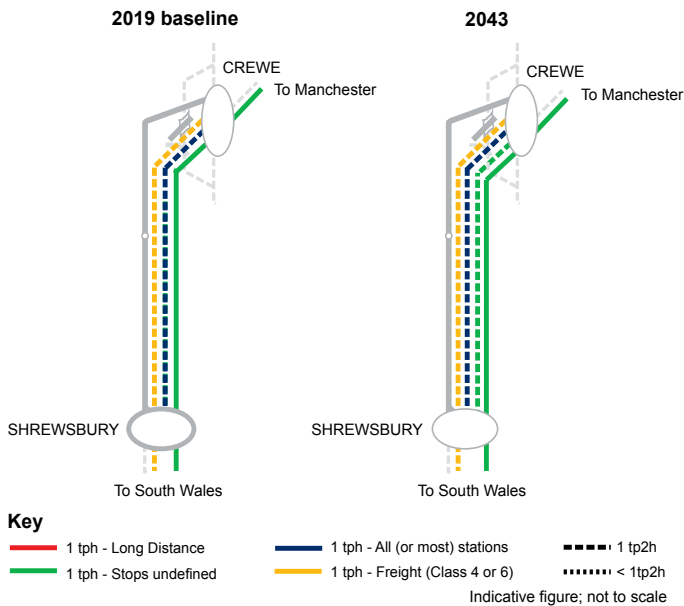

6.2.5.3 Shrewsbury Crewe Junction – Crewe Gresty Lane Junction Overview

This route provides a mixture of local and long distance passenger traffic and heavy freight traffic.

This is reflected in Figure 6.14.

Constraints in 2043

Timings on this route are entirely dictated by the timings at other constrained network locations, and the routes that they serve.

Making best use of current infrastructure, up to 2043

Theoretically, the 2043 ITSS and 2043 freight forecast could be run over this route. However, accommodation of the 2043 ITSS will be heavily dependant on constraints elsewhere on the network.

Interventions for 2043

Given the committed 2019 base infrastructure, it is likely that no interventions will be required to deliver the 2043 ITSS, and projected freight growth to 2043.

6.2.6 Shrewsbury to Chester

6.2.6.1 Shrewsbury Crewe Junction – Wrexham General station Overview

This route accommodates a mixture of long distance passenger traffic and freight traffic.

Constraints in 2043

The timings of trains onto and off this part of this route are heavily dictated by constraints at other major network nodes, such as Newport on the South Wales Main Line, and Birmingham New Street.

In the longer term, the 2043 ITSS and 2043 freight growth forecast require the current number of passenger and freight services to increase.

Making best use of current infrastructure, up to 2043

In order to maintain an acceptable performance buffer, the line could accommodate up to two passenger trains per hour in each direction, or one passenger train alongside one heavy freight service. However, practical delivery of these is dependent on the wider network constraints described above.

The scale of the infrastructure enhancement required is driven by the number of services timetabled. If there were an opportunity to reduce these services, for instance by terminating the long distance high speed service from London Euston at Shrewsbury, or by redirecting certain services to run between Chester and Shrewsbury via Crewe, the scale of enhancement required would be reduced. However, this may reduce the journey options available at Wrexham.

Interventions for 2043

In order to deliver the 2043 ITSS and projected freight growth to 2043, this Route Study has identified that additional intermediate signals will be required as detailed in Table 6.22.

The introduction of ETCS is likely to have capacity and performance benefits on this route.

Table 6.22. Assessment of Option a: Headway reduction through additional signalling

Summary of intervention:

Additional signalling will be required to deliver the 2043 ITSS and 2043 freight specification.

Output assessment:

It will be necessary to install at least one additional signal section, in each direction, between Gobowen and Wrexham.

In addition, it is likely that a headway reduction between Shrewsbury and Gobowen will be required, for reasons of performance and timetabling flexibility. This can be achieved through the installation of an additional multi-aspect signal, in each direction, between Shrewsbury and Gobowen.

Affordability assessment

An estimate of the Anticipated Final Cost (AFC) is in progress and will be included in the final Route Study document.

6.2.6.2 Wrexham General Station (inclusive) to Chester

In the longer term, the 2043 ITSS predicts an increase in the frequency of passenger services. This is reflected in Figure 6.15.

The enhancement of this route section is considered under Section 5.1.11 as a choice for funders in CP6.

6.15: Wrexham to Chester

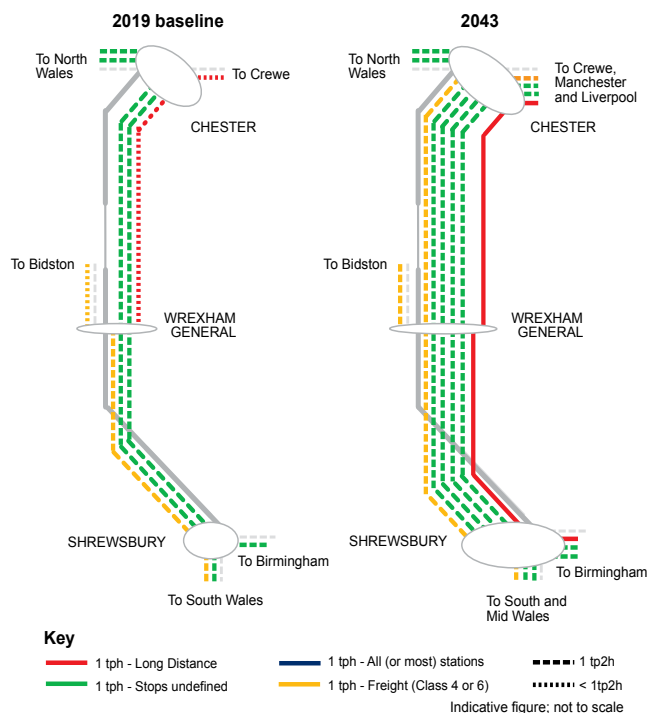

6.16: Cambrian Lines



6.2.7 Cambrian Lines

6.2.7.1 Shrewsbury (Sutton Bridge Junction) – Aberystwyth Overview

This route accommodates passenger services between Shrewsbury and Aberystwyth that operate at two-hourly intervals with services generally originating from and terminating at Birmingham International. The Welsh Government has recently confirmed that additional morning and evening peak services will operate from May 2015 for a trial period of three years. No freight services currently operate along this route

In the longer term, the 2043 ITSS predicts an increase in the frequency of passenger services. This is reflected in Figure 6.16.

This line is notable in that it has been fully converted to ETCS signalling to trial this system for wider application across the rail network.

Constraints in 2043

The Cambrian Main Line from Shrewsbury to Aberystwyth is primarily single track line, with loops provided to enable trains to pass each other. The current infrastructure can accommodate one train an hour in each direction, but the requirement for trains to pass each other at passing loops limits timetable flexibility and presents a performance risk when any train is running late. This can have a knock-on effect on other services from which it is difficult to recover.

It is recognised that there are aspirations for new stations on the Cambrian Coast Main Line (see Appendix C, Table H). In promoting the development of these new stations, consideration of the available network capacity will need to be made, especially in view of the enhanced frequency of passenger services that will commence operation in May 2015 for a trial period of three years, continuation of which is seen as a longer term choice for funders for this route.

Making best use of current infrastructure, up to 2043 specification

While it is theoretically possible to run an hourly passenger service on the baseline infrastructure, the Wales Route will be assessing the impact of introducing the additional services confirmed by the Welsh Government; this will effectively provide an hourly service at certain times of the day. The Wales Route will also be assessing what mitigation can be provided to ensure resilience in delivering this enhanced timetable.

Interventions for 2043

In considering the longer term requirement to meet the 2043 Indicative Train Service Specification, planning considerations should include the following:

- The impact of future enhancements to ETCS upon route capacity
- Future franchise specifications which may change service profiles
- Future rolling stock strategy, whereby more modern rolling stock may be better able to exploit prevailing line speed through better acceleration and braking characteristics
- Infrastructure enhancements which could potentially include assessments of line speed increases and / or extensions to loop lengths which would improve network capability and offer timetable flexibility and performance resilience. Such works should also consider closure of crossings where this would also facilitate line speed improvement with added safety benefit to the network.



6.2.7.2 Dovey Junction – Pwllheli Overview

This route accommodates passenger services between Dovey Junction and Pwllheli that operate at two-hourly intervals. Most services are a portion of the two-hourly service between Birmingham international and Aberystwyth in each direction that split from and join to this service at Machynlleth. No freight operates along the route. The route is a single line with passing loops.

This part of the Cambrian route has also been fully converted to ETCS signalling to trial this system for wider application across the UK rail network.

Constraints in 2043

Since no service increase is required, there are no constraints to delivery of the 2043 ITSS. In [Section 4.4.4](#), it is recognised that there can be seasonal variations in demand and this is a route where in summer months, passenger demand is higher than during winter months. This demand can generally be accommodated by managing the rolling stock fleet resources.

Making best use of current infrastructure, up to 2043 specification

The current infrastructure delivers the required service.

Interventions for 2043

No interventions are required.

Figure 6.17: Wrexham Central to Bidston

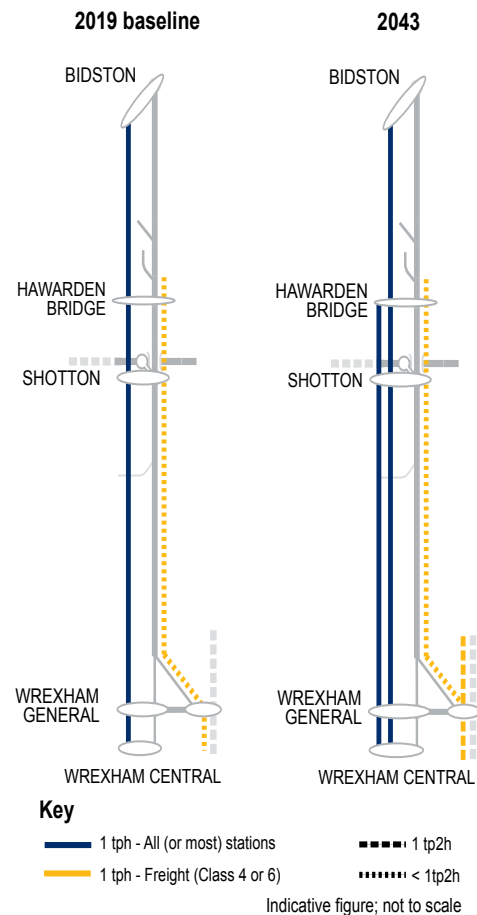

6.2.8 Heart of Wales

The 2043 ITSS suggests that no further increase in services will be required. No freight currently operates or is forecast to operate on this route in the future.

Making best use of current infrastructure, up to 2043 specification

There is no requirement to increase usage above today's levels.

Constraints in 2043

Demand to 2043 is likely to be met by the existing services. As such, there are no constraints to delivery of the 2043 ITSS.

Interventions for 2043

No interventions are required.

Section 5.1.6 described the additional services to be introduced on this route with effect from May 2015 for a trial period of three years. While there are no identified capacity issues for the route in either the short or longer term, the Heart of Wales Line Forum continues to actively promote use of the line. As part of this work the Forum is developing a range of options for improving the service offering along this route with the aim of increasing patronage. The rail industry will continue to support and work with the Heart of Wales Line Forum to consider opportunities for delivering affordable solutions to improve use of this route.

6.2.9 Wrexham Central - Bidston

Overview

This route accommodates an hourly local passenger service in each direction between Wrexham Central and Bidston. The route provides interchange facilities for Liverpool at Bidston, North Wales Coast and Chester at Shotton, and services to the West Midlands and South Wales at Wrexham General. Additionally a number of daily freight services serve the industrial sites at Buckley and Dee Marsh.

In the longer term, the 2043 ITSS and 2043 freight growth forecast predict an increase in both passenger and freight services. This is reflected in Figure 6.17

Constraints in 2043

The 2043 service specification, which adds an additional passenger service to Hawarden Bridge or Bidston, and a heavier freight train, cannot be accommodated on the baseline infrastructure, due to the constraints of the current signalling. Hawarden Bridge serves the growing industrial enterprise zone at Deeside so additional services to this station would provide for better rail connectivity to the Deeside Enterprise Zone. However, there is currently no way of turning round passenger services in the platform at Hawarden Bridge station which would currently require services to run empty to Birkenhead sidings, around 2/3 mile further north. In addition, the option to terminate services at Hawarden Bridge will prohibit clock face operation, and is also likely to result in sub-optimal rolling stock utilisation.

It would however be possible, each hour, to extend a second passenger service to Bidston, although this is also constrained by the current signalling on the route.

Making best use of current infrastructure, up to 2043 specification

Service frequency cannot be improved beyond today's maximum total level of two trains per hour, consisting of either passenger services between Wrexham Central and Bidston, and/or freight services between Wrexham General and Dee Marsh.

Table 6.23. Assessment of Option A: Additional signalling sections**Summary of intervention:**

The length of the current signalling sections restrict the line from accommodating the 2043 freight and passenger service levels and speed mix. Therefore, the splitting of the signalling sections at two locations will be required.

Output assessment:

Splitting of the following block sections will be necessary:

- Wrexham to Penyfford, around Cefn-y-Bedd (both directions)
- Penyfford to Dee Marsh Junction, around Hawarden (both directions).

This will permit the timetabling of all required services.

Affordability assessment

An estimate of the Anticipated Final Cost (AFC) is in progress and will be included in the final Route Study document.

Interventions for 2043

In order to deliver the 2043 ITSS and projected freight growth to 2043, this Route Study has identified the intervention described in [Table 6.23](#).

The timing of this particular intervention should be considered in the light of the evolving national deployment of ETCS, and the developing status of this technology. ETCS has the potential to provide a more affordable and efficient solution in maximising the capacity available and delivering performance improvement along this part of the route.

It should also be recognised that a number of other studies have been conducted in recent years to look at how services on this route may be extended beyond Bidston, to improve connectivity with Liverpool.

At Bidston, the route from Wrexham joins the electrified Merseyrail system between West Kirby and Liverpool. This route is electrified with a third conductor rail using a direct current (DC) electrification system. East of Birkenhead the route operates underground below the river Mersey and Liverpool City Centre. The gradients and tunnel infrastructure preclude the operation of diesel passenger rolling stock in the Merseyrail tunnels.

The previous studies undertaken have considered:

- Extension of diesel services from Wrexham beyond Bidston to Birkenhead North; and,
- DC electrification of the route from Bidston to Wrexham Central.

The option of extending services to Birkenhead North require additional infrastructure to enable trains to turnback and provide low value for money. In addition extending DC electrification south from Bidston to Wrexham entails considerable capital cost investment which also provides for low value for money.

In the short to medium term, it is recognised that improving connectivity between Wrexham, and especially Deeside and the communities on the northern part of the Wrexham – Bidston route with Liverpool will grow in importance. The ability to improve frequency, aligned to the high frequency Merseyrail service levels between West Kirby, Bidston and Liverpool, will provide for improved connectivity and journey times.

In the longer term, potential deployment of rolling stock with the ability to operate on battery power for part of their journey may provide the ability in an affordable manner to improve the service offering between the Wrexham – Bidston route and Liverpool.

6.2.10 Chester - Holyhead (including Llandudno and Blaenau Ffestiniog branches)

6.2.10.1 Chester Station Overview

Chester station acts as a network hub, receiving through and terminating passenger services from six lines, with destinations served across North and South Wales, the Midlands, North West England, and London Euston. Occasional freight services run through, mainly to termini in North Wales. The 2043 ITSS and 2043 freight forecast anticipate a substantial increase in the number of both passenger and freight services calling or terminating at Chester. This is reflected in Figure 6.18

Constraints in 2043

The timings at this station are heavily dictated by constraints at other major network nodes, such as Newport on the South Wales Main Line, Manchester Piccadilly, and Crewe.

Consequently, there are two elements to this station which may prevent delivery of the services required in 2043: the availability of through platforms, and the track layout at Chester East Junction.

- There are only two through platforms generally available, Platforms 3 and 4. The 2043 ITSS can only be accommodated with optimum timings at these platforms, and the requirement to build Chester’s timetable around other constraints on the railway network will make these timings unachievable.
- The layout at Chester East Junction includes two points over which there are a high number of moves in different directions (points A and B in Figure 6.19). It is not possible to timetable the 2043 ITSS over this infrastructure.

Making best use of current infrastructure, up to 2043 specification

Best use will be dictated by constraints at other network nodes. Against the base service levels and infrastructure, there is capacity for additional services at Chester, but this is difficult to utilise effectively, due to the fixed timings of services required at other busy major network nodes. However, it is likely that a limited number of additional services could be timetabled through Chester before service trade-offs or additional infrastructure is required.

In seeking to deliver the optimum service choices in the future, trade-offs between running some services as through or terminating should be considered. However, due to a lack of platforms in which to terminate or turn round services at the western end of the station, this strategy may not release significant capacity or timetabling flexibility.

Nonetheless, the development of Chester station as a hub station implies the capability to connect into a range of services, and improvement in overall generalised journey times.

Interventions for 2043

In order to deliver the 2043 ITSS and projected freight growth to 2043, this Route Study has identified the interventions described in Tables 6.24 and 6.25. It is considered that these should be used to inform the resignalling of this part of the network planned in 2025 when future service specification might be considerably different to what operates today.

Figure 6.18: Chester

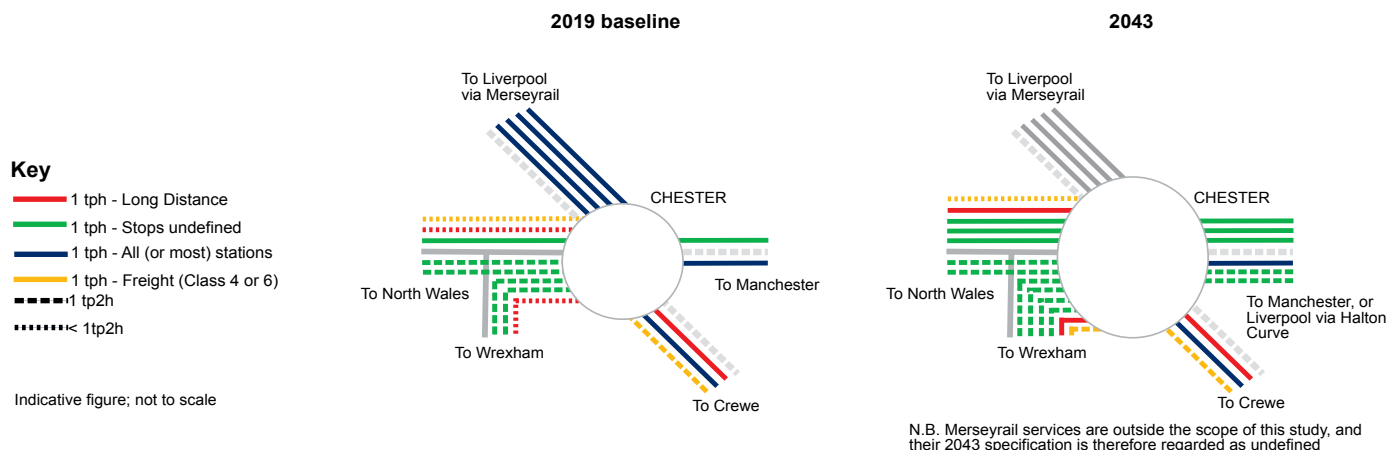
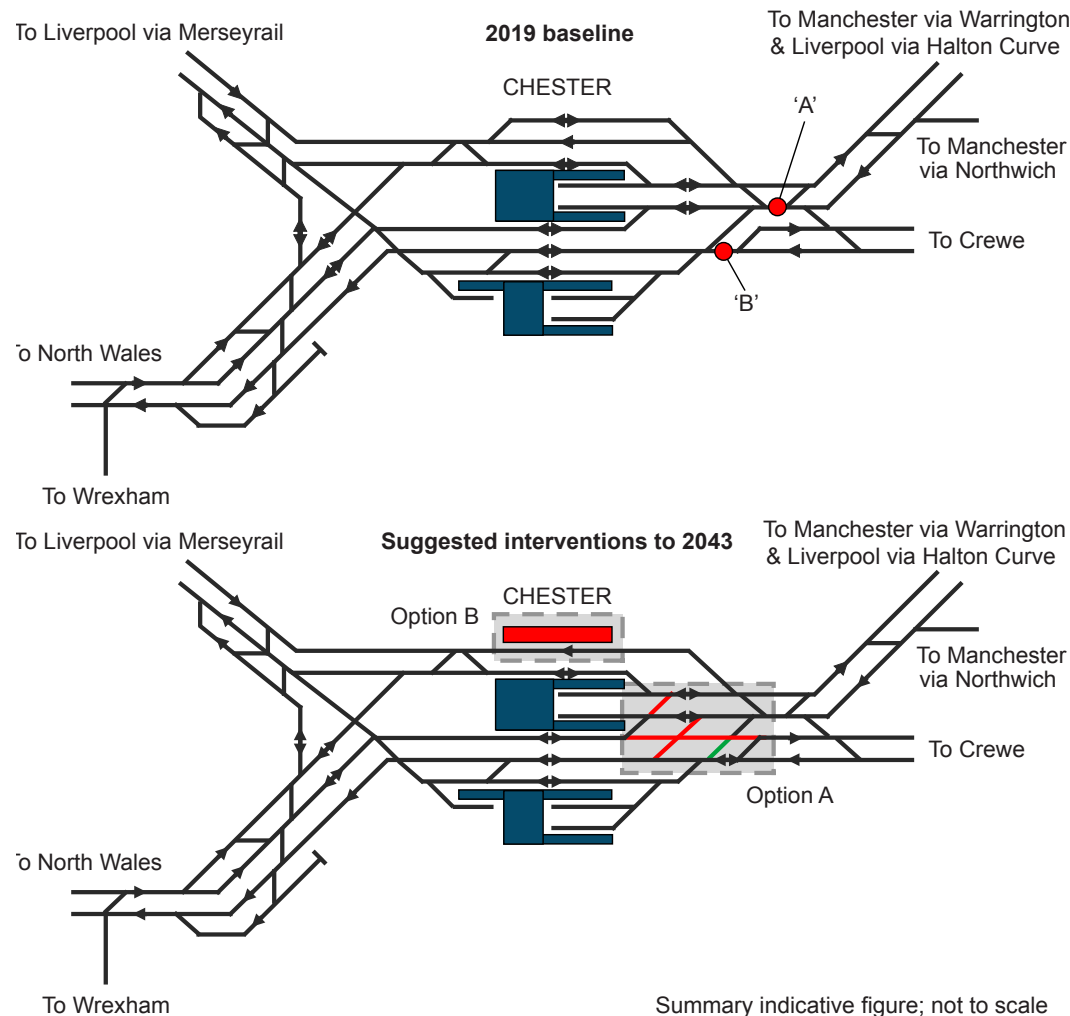

Figure 6.19: Chester station



Summary indicative figure; not to scale

Table 6.24. Assessment of Option A: Reconfiguration of Chester East Junction

Summary of intervention:
Chester East Junction currently funnels all traffic, in both directions, over one of two points. The junction should be reconfigured to separate these flows.

Output assessment:
Separation of flows, and therefore an increase in timetabling flexibility and a reduction in performance risk, can be achieved to a significant degree through the layout changes illustrated in Figure 6.19.

This allows arrivals and departures in parallel over each pair of lines, Crewe and Warrington. In addition, it reduces the number and duration of conflicting moves, with only one opposing move at each point.

Affordability assessment
This should be considered in the light of evolving future specification of services and should inform requirements for the planned resignalling of this part of the network in 2025.

Table 6.25. Assessment of Option B: Additional platform

Summary of intervention:
An additional through platform, Platform 8, may be required in order to provide necessary capacity when other network constraints are considered in a practical timetable.

Output assessment:
An additional platform on the northern side of the station, on the current Goods and Reception loops, would – with the installation of 3rd Rail DC electrification – be able to accommodate the Merseyrail services. This would allow Platform 7 to be used by through services from North Wales, freeing up Platform 4 so that it could be used in both direction, as required to relieve Platforms 3 and 7, or to turn round services from the north. This is likely to provide the necessary platform availability and flexibility to accommodate the 2043 ITSS, but should be considered in the light of timetable development around network constraints elsewhere.

Affordability assessment
This should be considered in the light of evolving future specification of services and should inform requirements for the planned resignalling of this part of the network in 2025.

Figure 6.20: Chester to Holyhead

6.2.10.2 Chester to Holyhead

Overview

This Main Line runs along the length of the North Wales coast, serving coastal towns and providing a direct link between ferries to Ireland from Holyhead, and destinations including Manchester, Birmingham and London. The majority of current traffic is passenger services, with occasional freight services to/from industrial destinations along the route. The 2043 ITSS and 2043 freight forecast envisage an increase in passenger services, but with little growth in the number of freight paths required. This is reflected in Figure 6.20

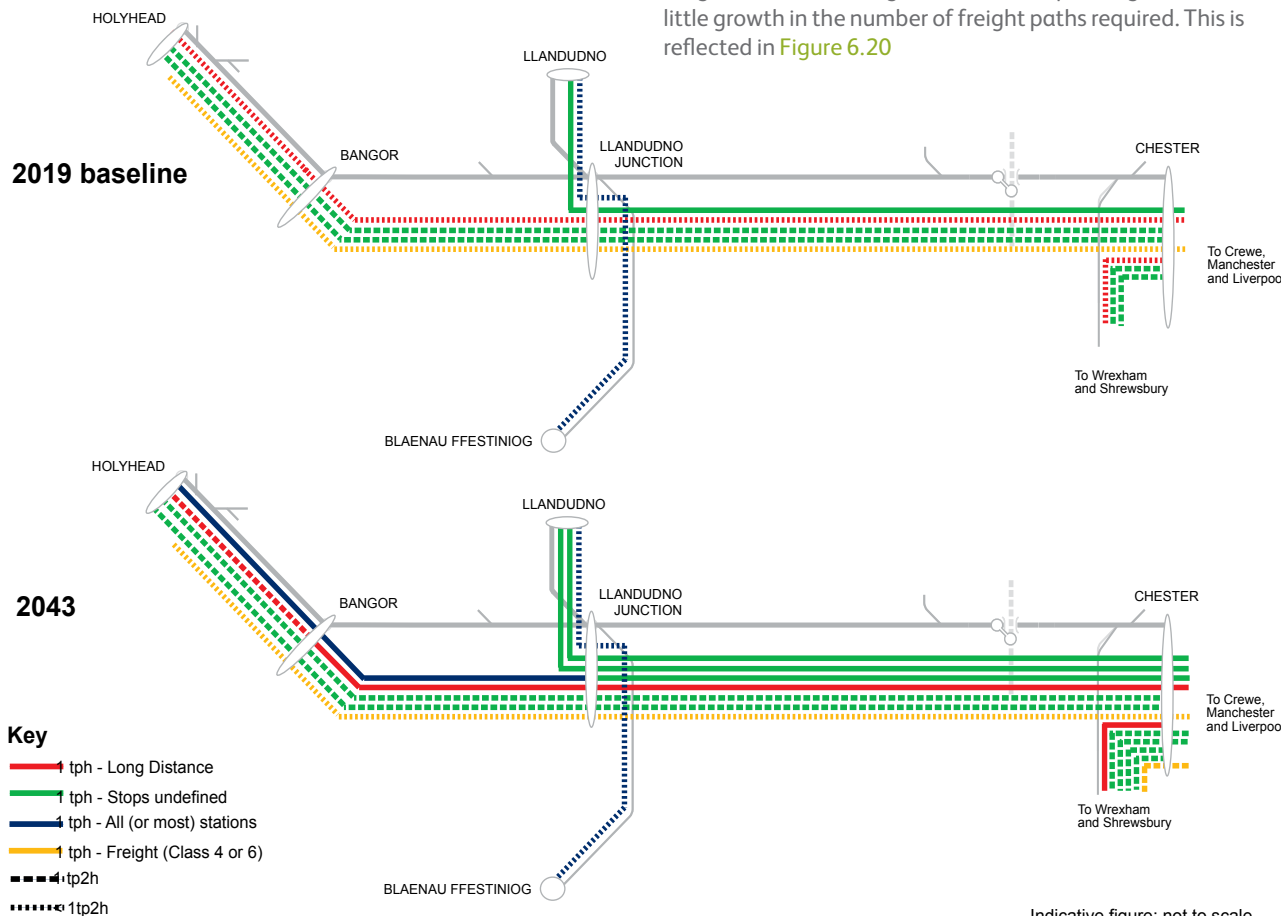

Indicative figure; not to scale

Constraints in 2043

The timings along this route are dictated by constraints at other major network nodes, such as Newport on the South Wales Main Line, Manchester Piccadilly, and Crewe. Consequently, the timetable for this route in the future will be significantly dictated by the timings of services at the other busy network nodes referred to above.

Even without this limitation, the baseline signalling will prohibit the delivery of the 2043 ITSS. There are two sections of route between Chester and Llandudno – the heaviest utilised part of the route – with long distances between signals. These dictate the whole line timetable. The scheduling of the full ITSS, even if possible given other network constraints, would present a significant performance risk.

Making best use of baseline infrastructure, up to 2043 specification

The maximum service level that could be accommodated on the baseline infrastructure, is four passenger trains per hour. This is an increase of one service per hour over today's most intensive hours. Practical delivery would be dependent on network constraints elsewhere, since it may prove difficult to find appropriate matching paths east of Chester.

Freight services could not be accommodated alongside this number of passenger services; consequently the passenger timetable would need to be reduced when freight services were scheduled. This may be considered a realistic trade-off, given the low number of freight paths required along this route.

Interventions for 2043

In order to deliver the 2043 ITSS and projected freight growth to 2043, this Route Study has identified the intervention described in Table 6.26.

The timing of this particular intervention should be considered in the light of the evolving national deployment of ETCS, and the developing status of this technology. ETCS has the potential to provide a more affordable and efficient solution in maximising the capacity available and delivering performance improvement along this part of the route.



6.2.10.3 Shotton Station Interchange

Section 5.1.10 identifies a choice for funders in CP6 to undertake development and planning work to improve the station environment at Shotton to enable this station to act as an effective interchange location in the longer term given potential future enhanced level of passenger service frequency specification on the North Wales Coast Main Line and Wrexham to Bidston route.

6.2.10.4 Llandudno Junction-Llandudno station Overview

This is a three mile double track branch line, connecting Llandudno Junction with Llandudno station, with one intermediate station. It is used exclusively by passenger services.

Constraints in 2043

Due to the short length of this line, and the requirement to accommodate a maximum of three passenger trains in an hour, there are no constraints along this line.

Making best use of baseline infrastructure, up to 2043 specification

The 2043 ITSS can be accommodated on this line.

Interventions for 2043

No interventions are required.

6.2.10.5 Llandudno Junction-Blaenau Ffestiniog Overview

This is a single track branch line with passing loops, connecting Llandudno Junction and Blaenau Ffestiniog. There are a number of small local stations along its route. It is used exclusively by passenger traffic; the 2043 ITSS does not envisage any increased service levels in the future.

Beyond Blaenau Ffestiniog the freight route to the former nuclear power station Trawsfynydd is currently mothballed. Welsh Government has advised that they would wish to see this route retained as part of the network in the longer term as this would provide potential to serve the Snowdonia Enterprise Zone.

Constraints in 2043

Since the service level does not change, there are no constraints to meeting the 2043 ITSS.

Making best use of baseline infrastructure, up to 2043 specification

The 2043 ITSS can be accommodated on this line.

Interventions for 2043

No interventions are required.

Table 6.26. Assessment of Option a: Additional signalling sections

Summary of intervention:

Long signalling sections (Absolute Block) restrict the line from accommodating the 2043 freight and passenger service levels. Therefore, the splitting of signalling sections at two locations will be required.

Output assessment:

Splitting of the following block sections will be necessary:

- Saltney Junction - Flint, around Shotton (both directions)
- Tyn-y-Morfa - Rhyl, around Prestatyn (both directions)

This is likely to permit the timetabling of all required services. Other network constraints may necessitate further signalling improvements, as would a requirement to timetable new freight services alongside the full passenger specification.

Affordability assessment

An estimate of the Anticipated Final Cost (AFC) is in progress and will be included in the final Route Study document.

07: Consultation and Next Steps

Highlights:

This chapter sets out how stakeholders have been consulted during the development of this Welsh Route Study Draft for Consultation.

It sets out how interested parties can respond to this Study.

All feedback, suggestions and ideas are encouraged.

7.1 Management and consultation process

Network Rail is taking a collaborative approach to the development of the Long Term Planning Process (LTPP). This Welsh Route Study is a key part of the process. Development of the Route Studies follows publication of the four Market Studies at the end of 2013 which set out the direction of travel for demand on the rail network in Great Britain over the next 30 years. The suite of Route Studies are a key next step in the process to develop the case for investment in the rail network in Control Period 6 and beyond.

This Welsh Route Study has been developed with the close involvement of a wide range of stakeholders.

This has meant that the work has been subject to comment and guidance as it has been developed. As ideas and interventions have been developed they have been challenged by an informed audience of key stakeholders.

7.2 Stakeholder groups

The Long Term Planning Process and the Route Studies developed within it are driven by the groups set out in [Chapter 1](#). These groups have been complemented by one to one discussions with individual members of the above groupings, during the development of this Route Study to discuss specific areas which stakeholders wished to raise as the work has developed.

Formal comment on this document is welcomed from any interested party who may wish to respond, whether or not they have been involved in the work to date. The Welsh Route Study Working Group will take into account responses in developing the final Welsh Route Study.

7.3 Consultation

A wide range of views will help to develop and take forward the process through to completion of the Welsh Route Study. If you wish to respond to any of the ideas and interventions set out within this Draft for Consultation, please email your comments to the following address:

WelshRouteStudy@networkrail.co.uk

Or by post to:

Welsh Route Study Consultation
Strategic Planner
Network Rail (Group Strategy)
5 Callaghan Square
Cardiff
CF10 5BT

Respondents should clearly indicate if they wish all or part of their response to remain confidential and, if so, specifically state to which organisations they wish the information to remain confidential.

Otherwise, it is expected that the responses will be published on the Network Rail website and may be quoted in future. Where a response is made in confidence, it should be accompanied by an unrestricted copy excluding the confidential information that can be treated as above. The names of respondents may be published in future documents or on the website, unless a respondent indicates that it wishes its name to be withheld.

Responses are welcome in the medium of English or Welsh.

This Welsh Route Study is only being published on the Network Rail website, on behalf of the industry, with a formal consultation period of 90 days. The closing date for receiving responses is 9 June 2015.

7.4 Next steps

To conclude the final Route Study strategy for publication in 2015, the Welsh Route Study Working Group will consider any further work which may be required as a result of the formal consultation responses.

Further details of the Long Term Planning Process, including an overview of the work, frequently asked questions and contact details for preceding work, including Market Studies, and other Route Studies can be found on the Network Rail website:

www.networkrail.co.uk/long-term-planning-process/



The choices identified for the next Control Period (CP6, commencing April 2019) have been categorised from a financial and socio-economic perspective.

In the context of the financial perspective, CP6 choices have been categorised into either of the following:

- (a) choices which worsen the rail industry's net operating position (in other words, the additional operating costs exceed the value of revenue generated); or
- (b) choices which improve the rail industry's net operating position. For these schemes, the Route Study also indicates the extent to which this improvement is able to cover the capital cost of the initial investment.

The choices have also been appraised from a wider 'socio-economic' perspective, which compares the value of benefits to users and non-users to the net financial cost to funders. The appraisals have been conducted in line with funders' guidelines, in particular WelTAG, the Welsh transport planning and appraisal guidance and WebTAG, the Department for Transport's appraisal guidelines.

Option 7A: Train lengthening for services between Cardiff and Manchester (Five vehicle option)	
Conditional Output	CO5 and CO6 - to provide sufficient capacity for passengers travelling on services between Cardiff and Manchester via the Marches, taking into account anticipated growth.
Timeframe	CP6 (specifically 2023).
Objectives	To accommodate forecasted demand and reduce on-train crowding on long distance services between Cardiff and Manchester. These services are also used by passengers travelling between local stations on the Marches line.
Description	Additional vehicle(s) for services require extra capacity to meet anticipated demand growth by 2023 between Cardiff and Manchester during the day.
Infrastructure requirement	No infrastructure work required within the Welsh Route Study area. None expected outside Welsh Route Study area - subject to confirmation from other Route Studies.
Operational requirement	Most of the two- or three- car sets to be lengthened with one additional vehicle, with two services lengthening with two additional vehicles.
Passenger impact	Provide sufficient capacity to meet the anticipated demand growth to 2023.
Freight impact	None.
Relates to other options	Option 7B: only lengthen services that have a value for money categorisation at medium or higher.
Socio-economic Value for money categorisation	Low.
Rail Industry financial categorisation	Increases operating subsidies.
Note	The operating costs are estimated from a high level diagramming assumption and subject to further assessment. The value for money case is likely to improve if the diagramming and formation are not constrained.

Option 7A Financial and socio-economic categorisation			
Rail industry financial impact (Categorisation of Revenue, Operating costs & Capital costs over appraisal period)		Socio-economic impact (WebTAG VfM category, see summary TEE table for further details)	
Scheme increases operating subsidies (i.e. $R - O < 0$)	<input checked="" type="checkbox"/>	Low	
Scheme decreases operating subsidies (i.e. $R - O > 0$)	Low capital cost coverage (i.e. $(R - O) / C < 33\%$)		N/A
	Medium capital cost coverage (33-66%)		N/A
	High capital cost coverage (66-100%)		N/A
Positive financial case (> 100%)	<input type="checkbox"/>		

Option 7A Summary TEE (Transport Economic Efficiency) table	
30 year appraisal	£m (2010 PV)
Costs (Present Value)	
Investment Cost	0.00
Operating Cost	27.33
Revenue	-15.39
Other Government Impacts (road infrastructure costs)	-0.04
Total costs	11.91
Benefits (Present Value)	
Rail user benefits	18.58
Non user benefits	0.30
Rail user & non user disruption disbenefits	0.00
Current TOCs revenue	0.00
Current TOCs/ NR opex	0.00
Other Government Impacts (indirect taxation)	-2.39
Total Quantified Benefits	16.49
NPV	4.59
Quantified BCR	1.39

Option 7B Train lengthening for services between Cardiff and Manchester (Two vehicle option)	
Conditional Output	CO5 and CO6 - to provide sufficient capacity for passengers travelling on services between Cardiff and Manchester via the Marches, taking into account anticipated growth.
Timeframe	CP6 (specifically 2023).
Objectives	To accommodate forecasted demand and reduce on-train crowding on long distance services between Cardiff and Manchester, these services are also used by passengers travelling between local stations on the Marches line.
Description	Additional vehicle for selected services between Cardiff and Manchester during the day, only lengthening the services with a value for money categorisation at medium or higher.
Infrastructure requirement	No infrastructure work required within the Welsh Route Study area. None expected outside Welsh Route Study area - subject to confirmation from other Route Studies.
Operational requirement	Two-car sets to be lengthened with one additional vehicle.
Passenger impact	Provide sufficient capacity to meet the anticipated demand growth to 2023.
Freight impact	None.
Relates to other options	Option 7A: lengthen all services require extra capacity to meet anticipated demand by 2023, including services that have a poor or low value for money categorisation.
Socio-economic Value for money categorisation	Financially positive, equivalent to a very high value for money categorisation. The option is financially positive as the net costs to government are negative. The revenue to government exceeds the operating costs to government over the appraisal period.
Rail Industry financial categorisation	Decreases operating subsidies.
Note	The operating costs are estimated from a high level diagramming assumption and subject to further assessment.

Option 7B Financial and socio-economic categorisation		
Rail industry financial impact (Categorisation of Revenue, Operating costs & Capital costs over appraisal period)		Socio-economic impact (WebTAG VfM category, see summary TEE table for further details)
Scheme increases operating subsidies (i.e. $R - O < 0$)		<input type="checkbox"/>
Scheme decreases operating subsidies (i.e. $R - O > 0$)	Low capital cost coverage (i.e. $(R - O) / C < 33\%$)	N/A
	Medium capital cost coverage (33-66%)	N/A
	High capital cost coverage (66-100%)	N/A
	Positive financial case (> 100%)	<input checked="" type="checkbox"/>

Option 7B Summary TEE (Transport Economic Efficiency) table	
30 year appraisal	£m (2010 PV)
Costs (Present Value)	
Investment Cost	0.00
Operating Cost	10.05
Revenue	-12.16
Other Government Impacts (road infrastructure costs)	-0.03
Total costs	-2.13
Benefits (Present Value)	
Rail user benefits	14.15
Non user benefits	1.33
Rail user & non user disruption disbenefits	0.00
Current TOCs revenue	0.00
Current TOCs/ NR opex	0.00
Other Government Impacts (indirect taxation)	-2.44
Total Quantified Benefits	13.05
NPV	15.18
Quantified BCR	-6.13

Option 8A Provision of 25kV electrification from Crewe/Warrington and Llandudno/Holyhead via Chester (include committed train services only)	
Conditional Output	CO21 to CO24 - to achieve improved connectivity between North Wales Coast and London, Manchester, Liverpool, and Chester.
Timeframe	CP6 (specifically 2024).
Objectives	To increase end to end journey speed for the long distance services to/ from North Wales Coast by switching to electric operation.
Description	Services to/ from the North Wales Coast convert to electric traction, include 25kV overhead electrification of the following section: <ul style="list-style-type: none"> ● Crewe to Holyhead via Chester; and ● Acton Grange Junction to Chester.
Infrastructure requirement	Infrastructure work required to modify a high number of civil engineering structures along the route to enable gauge clearance for 25kV electrification and requirements to provide new bulk electricity supply points along the route. Requirements of depot and stabling facilities and platform extension for electric passenger rolling have not been assessed.
Operational requirement	The electrified infrastructure allows trains to run at a higher speed and provides savings on operating costs compared to diesel operation. The train services to be converted to electric traction include (as in today's timetable): <ul style="list-style-type: none"> ● London to North Wales ● Manchester to North Wales ● Crewe to Chester.
Passenger impact	Improve end to end journey speed for long distance services with an reduced journey time.
Freight impact	Improve end to end journey speed for freight trains operate on the North Wales Coast.
Relates to other options	Option 9A: North Wales Coast journey time improvement (include enhanced level of uncommitted train services), where additional uncommitted future services are considered.
Socio-economic Value for money categorisation	Poor.
Rail Industry financial categorisation	Decreases operating subsidies.
Note	This assessment does not include any "wider economic benefits" to the region. Whilst the inclusion of wider economic impacts will increase the stated benefits of the scheme, it is unlikely to materially change the value for money categorisation.

Option 8A Financial and socio-economic categorisation			
Rail industry financial impact (Categorisation of Revenue, Operating costs & Capital costs over appraisal period)		Socio-economic impact (WebTAG VfM category, see summary TEE table for further details)	
Scheme increases operating subsidies (i.e. $R - O < 0$)	<input type="checkbox"/>	Poor	
Scheme decreases operating subsidies (i.e. $R - O > 0$)	Low capital cost coverage (i.e. $(R - O) / C < 33\%$)		<input checked="" type="checkbox"/>
	Medium capital cost coverage (33-66%)		N/A
	High capital cost coverage (66-100%)		N/A
Positive financial case (> 100%)	<input type="checkbox"/>		

Option 8A Summary TEE (Transport Economic Efficiency) table	
60 year appraisal	£m (2010 PV)
Costs (Present Value)	
Investment Cost	764.5
Operating Cost	-178.1
Revenue	-63.31
Other Government Impacts (road infrastructure costs)	-0.15
Total costs	522.9
Benefits (Present Value)	
Rail user benefits	136.0
Non user benefits	141.5
Rail user & non user disruption disbenefits	-54.1
Current TOCs revenue	0.0
Current TOCs/ NR opex	0.0
Other Government Impacts (indirect taxation)	-48.4
Total Quantified Benefits	175.0
NPV	-348.0
Quantified BCR	0.33

Option 8B Provision of 25kV electrification from Crewe/Warrington and Llandudno/Holyhead via Chester (include enhanced level of uncommitted train services)	
Conditional Output	CO21 to CO24 - to achieve improved connectivity between North Wales Coast and London, Manchester, Liverpool, and Chester.
Timeframe	CP6 (specifically 2024).
Objectives	To increase end to end journey speed for the long distance services to/ from North Wales Coast by switching to electric operation.
Description	Services to/ from the North Wales Coast convert to electric traction, include 25kV overhead electrification of the following section: <ul style="list-style-type: none"> ● Crewe to Holyhead via Chester; ● Acton Grange Junction to Chester ● Halton Chord*.
Infrastructure requirement	Infrastructure work required to modify a high number of civil engineering structures along the route to enable gauge clearance for 25kV electrification and requirements to provide new bulk electricity supply points along the route. Requirements of depot and stabling facilities and platform extension for electric passenger rolling have not been assessed.
Operational requirement	The electrified infrastructure allows trains to run at a higher speed and provides savings on operating costs compared to diesel operation. The enhanced level of train services to be converted to electric traction include: <ul style="list-style-type: none"> ● London to Holyhead (1tph) ● Manchester to Llandudno (2tph) ● Liverpool to Holyhead (1tph) ● Crewe to Chester (1tph).
Passenger impact	Improve end to end journey speed for long distance services with an reduced journey time.
Freight impact	Improve end to end journey speed for freight running through Chester and the North Wales Coast.
Relates to other options	Option 9A: North Wales Coast journey time improvement (include committed services only).
Socio-economic Value for money categorisation	Poor.
Rail Industry financial categorisation	Decreases operating subsidies.
Note	The appraisal includes future services in the indicative timetable specification and assumed these will convert to electric traction. The services reflected in the indicative timetable specification are not committed and only assumed to be operational and deliverable for the purpose of this study. Further assessment would be required to validate this timetable option. This should be noted when comparing to other electrification schemes. This assessment does not include any "wider economic benefits" to the region. Whilst the inclusion of wider economic impacts will increase the stated benefits of the scheme, it is unlikely to materially change the value for money categorisation. * The cost of works necessary to deliver track, signalling and electrification works at Halton Chord necessary to enable electric passenger services between Chester and Liverpool in both directions are not included.

Option 8B Financial and socio-economic categorisation			
Rail industry financial impact (Categorisation of Revenue, Operating costs & Capital costs over appraisal period)		Socio-economic impact (WebTAG VfM category, see summary TEE table for further details)	
Scheme increases operating subsidies (i.e. $R - O < 0$)		<input type="checkbox"/>	Poor
Scheme decreases operating subsidies (i.e. $R - O > 0$)	Low capital cost coverage (i.e. $(R - O) / C < 33\%$)	<input checked="" type="checkbox"/>	
	Medium capital cost coverage (33-66%)	N/A	
	High capital cost coverage (66-100%)	N/A	
Positive financial case (> 100%)		<input type="checkbox"/>	

Option 8B Summary TEE (Transport Economic Efficiency) table	
30 year appraisal	£m (2010 PV)
Costs (Present Value)	
Investment Cost	764.5
Operating Cost	-186.2
Revenue	-101.1
Other Government Impacts (road infrastructure costs)	-0.25
Total costs	477.0
Benefits (Present Value)	
Rail user benefits	188.6
Non user benefits	192.0
Rail user & non user disruption disbenefits	-54.1
Current TOCs revenue	0.0
Current TOCs/ NR opex	0.0
Other Government Impacts (indirect taxation)	-65.3
Total Quantified Benefits	261.2
NPV	-215.7
Quantified BCR	0.55

Option 9A Improved linespeeds along North Wales Coast between Chester and Llandudno/Holyhead	
Conditional Output	CO21 to CO24 - to achieve improved connectivity between North Wales Coast and London, Manchester, Liverpool, and Chester.
Timeframe	CP6 (specifically 2019).
Objectives	To increase end to end journey speed for services to/ from North Wales Coast by improving journey time between Chester and destinations on the North Wales Coast.
Description	Increase linespeeds for section between Chester and destinations on the North Wales Coast to maximise capability provided by the signalling upgrade, to a maximum of 100mph where conditions allow.
Infrastructure requirement	Infrastructure work relating to track geometry and gauge clearance to maximise speed on the line.
Operational requirement	Trains to run at a higher speed and reduce overall journey time to/ from the North Wales Coast. Depending upon stopping patterns of trains, journey time savings vary between one to eight minutes.
Passenger impact	Improve end to end journey speed for long distance services with an reduced journey time.
Freight impact	Improves end to end journey speed for freight running through Chester and the North Wales Coast.
Relates to other options	Option 8A and 8B: The North Wales Coast electrification aims to improve journey speed on the North Wales Coast by switching service operation from diesel to electric.
Socio-economic Value for money categorisation	Financially positive, equivalent to a very high value for money categorisation.
Rail Industry financial categorisation	Decreases operating subsidies.
Note	None.

Option 9A Financial and socio-economic categorisation			
Rail industry financial impact (Categorisation of Revenue, Operating costs & Capital costs over appraisal period)		Socio-economic impact (WebTAG VfM category, see summary TEE table for further details)	
Scheme increases operating subsidies (i.e. $R - O < 0$)			
Scheme decreases operating subsidies (i.e. $R - O > 0$)	Low capital cost coverage (i.e. $(R - O) / C < 33\%$)	N/A	
	Medium capital cost coverage (33-66%)	N/A	
	High capital cost coverage (66-100%)	N/A	
	Positive financial case (> 100%)	<input checked="" type="checkbox"/>	

Option 9A Summary TEE (Transport Economic Efficiency) table	
30 year appraisal	£m (2010 PV)
Costs (Present Value)	
Investment Cost	14.6
Operating Cost	0.00
Revenue	-30.2
Other Government Impacts (road infrastructure costs)	-0.07
Total costs	-15.7
Benefits (Present Value)	
Rail user benefits	38.1
Non user benefits	5.6
Rail user & non user disruption disbenefits	-1.2
Current TOCs revenue	0.0
Current TOCs/ NR opex	0.0
Other Government Impacts (indirect taxation)	-5.9
Total Quantified Benefits	36.6
NPV	52.3
Quantified BCR	-2.3

Appendix B: Mapping of Choices for Funders to Conditional Outputs

Conditional Outputs:	
CP6 Choices:	
CO1	Cardiff peak capacity
CO8	Cardiff Central station capacity
CO30	South Wales Main Line JTI
CO32	Valley lines JTI
CO37	South West Wales connectivity
CO38	Heart of Wales line peak arrivals in Swansea
Longer term strategy to 2043:	
CO2	Swansea peak capacity
CO7	Cardiff – Birmingham all day capacity
CO9a	Providing sufficient growth for freight markets identified in Freight Market Study
CO9b	Freight capacity for steel traffic between Llanwrn and Port Talbot (Margam)
CO10	Cardiff – London connectivity
CO11	Swansea – London connectivity
CO12	Cardiff – Bristol connectivity
CO13	Swansea – Bristol connectivity
CO14	Cardiff – Birmingham connectivity
CO15	Cardiff – Leicester connectivity
CO16	Cardiff – Sheffield connectivity
CO17	Cardiff – Manchester connectivity
CO18	Cardiff – Leeds connectivity
CO29	Newport/Severn Tunnel Junction – Bristol/Bath connectivity
CO31	Improved service frequency to local stations between Cardiff Central and Swansea.
CO33	Ebbw Vale – Newport connectivity
CO34	Lydney/Chepstow – Bristol connectivity
CO35	Cardiff – Gloucester JTI
CO36	North-South Wales connectivity
CO41	Airport connectivity
CO43	Major ports connectivity
CO44	Improving connectivity for leisure markets at weekends
CO45	Access to higher education establishments and other social infrastructure
CO46	Improved passenger satisfaction
CO47	Integrated transport

Valley Lines

CP6 Choices:

- Valley Lines train lengthening and associated platform lengthening
- Further phased programme of network enhancements to the Valley Lines including development of Cardiff City Capital Region Metro

Longer-term strategy to 2043:

- Consideration of layout improvements to remove capacity and performance constraints at Cardiff Queen Street and Cardiff West/Radyr Branch Junctions – to be assessed in conjunction with emerging Metro considerations
- Improve connectivity between Ebbw Vale/Abertillery and Newport
- Headway improvements

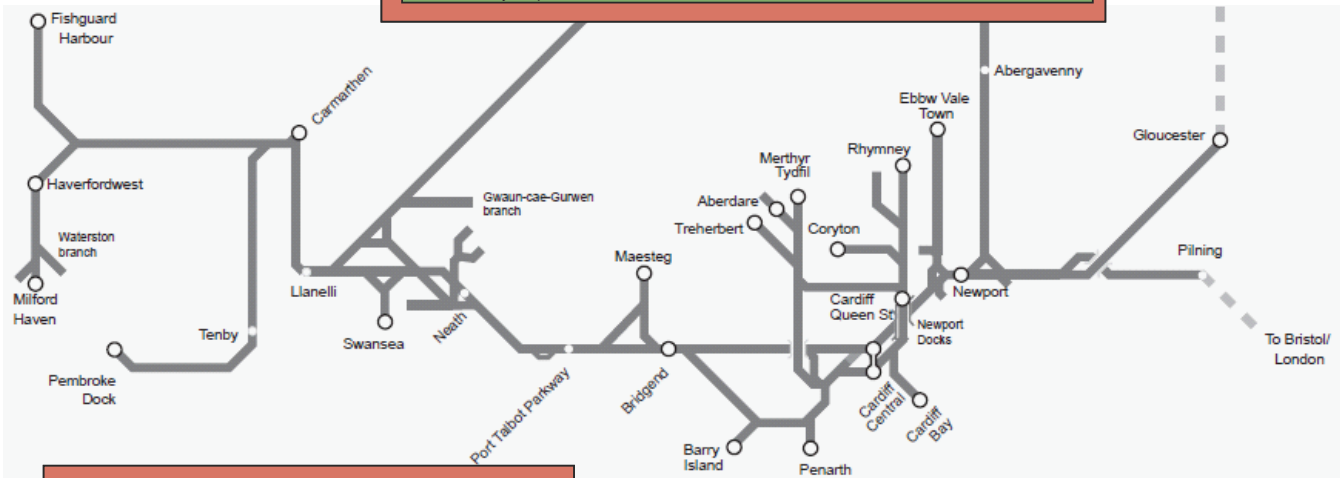

South West Wales

CP6 Choices:

- Journey time improvements that can be realised by closure of level crossings
- Continuation of recently announced additional services on Heart of Wales line

Longer-term strategy to 2043:

- Improve connectivity from Fishguard, Pembroke, Milford Haven and Carmarthen to Swansea

South Wales Main Line

CP6 Choices:

- Relief line speed increases
- Cardiff Central station enhancement (including lengthening Platform 0)

Longer-term strategy to 2043:

- Optimise 4 track railway capability (ETCS, high speed connections / grade separation)
- Grade separation at Maindee West Junction
- Additional platform face(s) at Newport
- Cardiff West Junction remodelling
- Headway improvements
- Additional peak services Cardiff to Abergavenny including associated infrastructure enhancements at Abergavenny station

Conditional Outputs:	
CP6 Choices:	
CO5	Marches line all day capacity
CO6	Cardiff – Manchester all day capacity
CO38	Heart of Wales line peak arrivals in Shrewsbury
CO39	Cambrian Line connectivity and generalised journey time improvements
Longer term strategy to 2043:	
CO4	Shrewsbury peak capacity
CO9a	Providing sufficient growth for freight markets identified in Freight Market Study
CO9c	Freight capacity on the Marches line
CO17	Cardiff – Manchester connectivity
CO19	Shrewsbury – London connectivity
CO20	Shrewsbury – Liverpool connectivity
CO36	North-South Wales connectivity
CO39	Cambrian line connectivity
CO41	Airport connectivity
CO42	HS2 connectivity
CO44	Improving connectivity for leisure markets at weekends
CO45	Access to higher education establishments and other social infrastructure.
CO46	Improved passenger satisfaction
CO47	Integrated transport

Cambrian Lines

CP6 Choices:

- Continuation of recently announced additional services on Cambrian line.

Longer-term strategy to 2043:

- Improve connectivity to/from mid Wales by improving frequency and/or journey time.

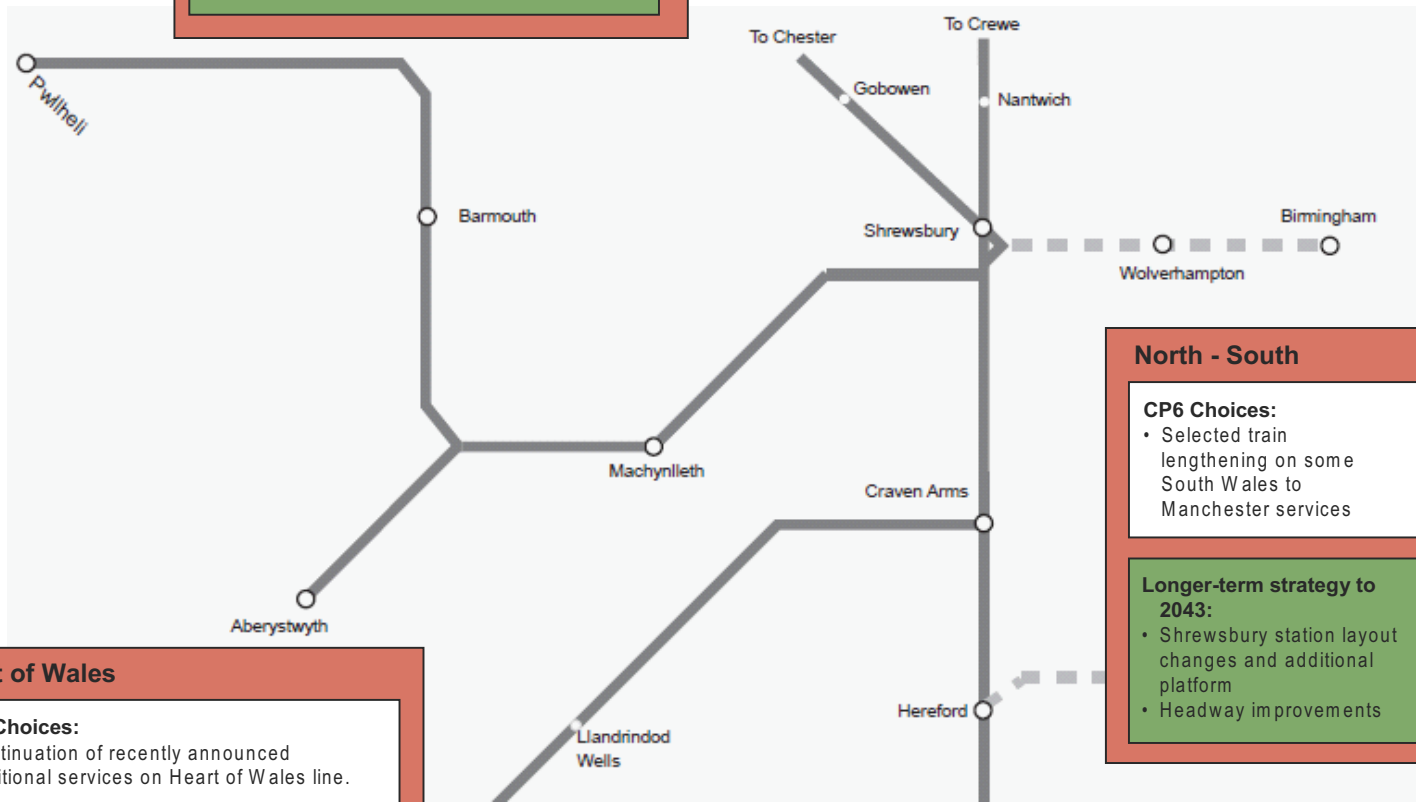

Heart of Wales

CP6 Choices:

- Continuation of recently announced additional services on Heart of Wales line.

North - South

CP6 Choices:

- Selected train lengthening on some South Wales to Manchester services

Longer-term strategy to 2043:

- Shrewsbury station layout changes and additional platform
- Headway improvements

Conditional Outputs:	
CP6 Choices:	
CO22	North Wales Coast – Manchester connectivity
CO23	North Wales Coast – Liverpool connectivity
CO28	Wrexham – Liverpool connectivity
Longer term strategy to 2043:	
CO3	Chester peak capacity (from North Wales)
CO9a	Providing sufficient growth for freight markets identified in Freight Market Study
CO21	North Wales Coast – London connectivity
CO24	North Wales Coast – Chester connectivity
CO25	Wrexham – London connectivity
CO26	Wrexham – Shrewsbury connectivity
CO27	Wrexham – Birmingham connectivity
CO36	North-South Wales connectivity
CO40	Connectivity to Deeside
CO41	Airport connectivity
CO42	HS2 connectivity
CO43	Major ports connectivity
CO44	Improving connectivity for leisure markets at weekends
CO45	Access to higher education establishments and other social infrastructure.
CO46	Improved passenger satisfaction
CO47	Integrated transport

North Wales Coast

CP6 Choices:

- Development of North Wales Coast modernisation (potentially CP7 to align with future rolling stock and franchise strategy)
- Line speed improvements to realise journey time improvement
- Development/planning associated with Shotton Station Interchange

Longer-term strategy to 2043:

- Shotton station interchange enhancement
- Chester remodelling (as part of Chester area resignalling)

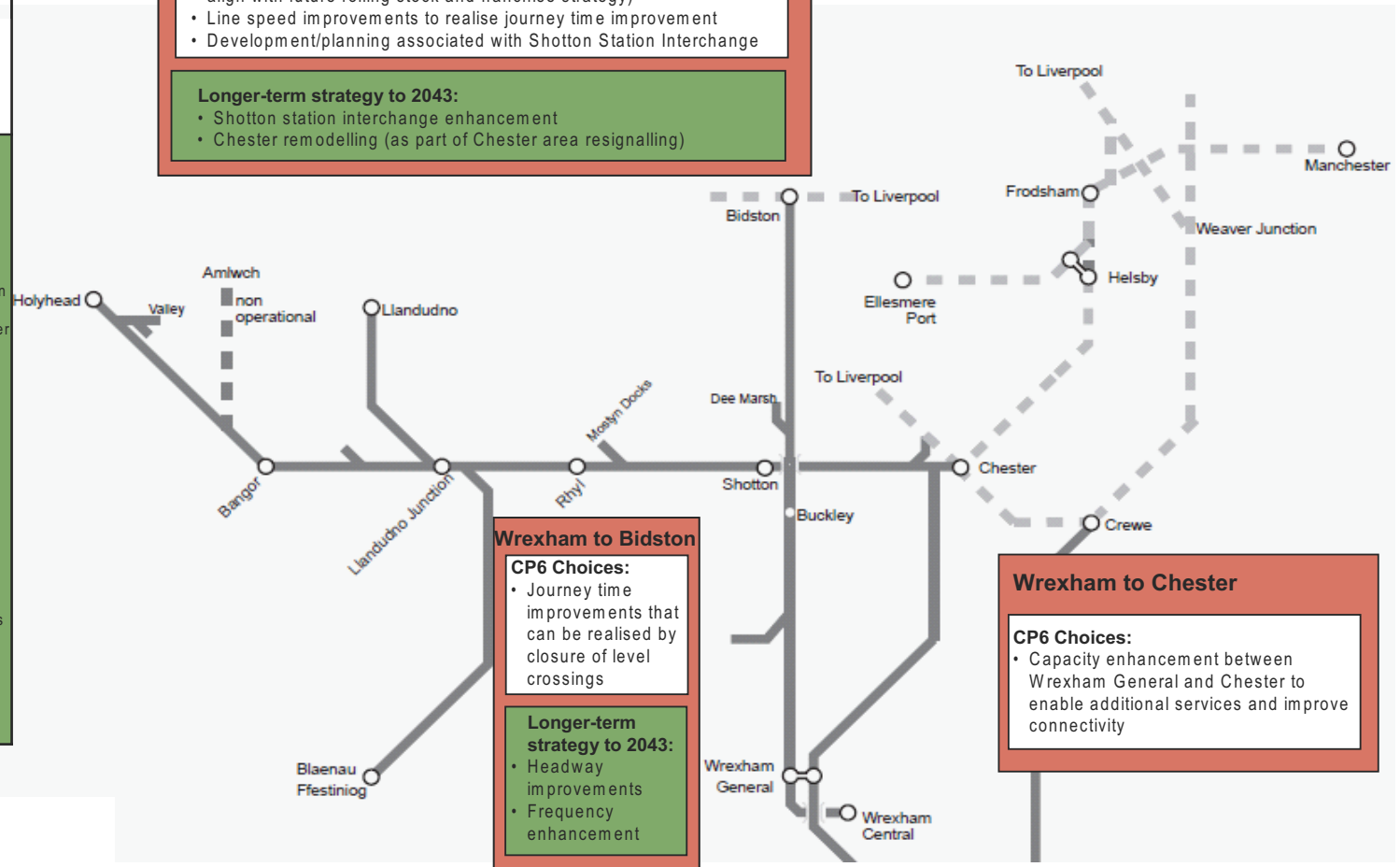

Wrexham to Bidston

CP6 Choices:

- Journey time improvements that can be realised by closure of level crossings

Longer-term strategy to 2043:

- Headway improvements
- Frequency enhancement

Wrexham to Chester

CP6 Choices:

- Capacity enhancement between Wrexham General and Chester to enable additional services and improve connectivity

Appendix C: Other Stakeholder Aspirations

Review of National and Regional Transport Strategies within Wales and the Borders and other Stakeholder aspirations

Key Welsh Route Stakeholders

This appendix sets out the main aspirations of Welsh Government and the regional authorities within Wales and the Borders, and where appropriate explains how these have been aligned with the conditional outputs being considered by the Welsh Route Study.

The National Transport Plan for Wales was last published in March 2010. Work is currently underway to publish a new National Transport Plan for Wales in mid 2015. In developing the Welsh Route Study, Welsh Government has been a key industry stakeholder and evidence developed for the Welsh Route Study will be used in the development of the new National Transport Plan for Wales.

Up to April 2014, there were four Regional Transport Consortia within Wales, each of which contained representation from the local county authorities within their area of influence and each consortia funded by Welsh Government. These consortia were:

- South East Wales Transport Consortia (SEWTA) – covering South East Wales
- South West Wales Integrated Transport Consortia (SWWITCH) – covering South West Wales
- Trafnidiaeth Canolbarth Cymru (TraCC) – covering mid Wales; and,
- TAITH – covering North Wales.

All four Transport Consortia published Regional Transport Plans setting out priorities for transport including rail in each of their areas. The Regional Transport Consortia were abolished in April 2014 (although TRACC still remain as an entity supported by the local authorities in mid-Wales), with local transport planning now residing with the local councils, although these have tended to group together within their areas under new umbrella organisations to co-ordinate the planning of transport.

The Local Enterprise Partnership (LEP) for the Marches, has also developed transport plans which include the rail route through the Marches between Newport and Shrewsbury and the route between Shrewsbury and Wolverhampton (which will be considered by the West Midlands & Chiltern Route Study).

Development of this Welsh Route Study has also seen engagement with the Passenger Transport Executives for Merseyside (Merseytravel) and Greater Manchester (GMPTE), and the border county authorities in Cheshire (which borders North East Wales), and Gloucestershire County Council (which borders South East Wales) all of which have important economic and cultural links Wales.

It should be noted that the Welsh Route Study does not consider new lines or new stations specifically unless a specific conditional output has been identified or for which such a requirement might be a funders priority.

Welsh Government

The Welsh Government National Transport Plan – draft, published on 10th December 2014 for consultation sets out the priorities for making Welsh Government investment in the rail network as follows:

- Providing enhanced connectivity for communities, business and key services, particularly where our investment can lever in UK or other sources of funding
- Ensuring Wales has high quality transport links and is well connected to the rest of the UK and internationally, particularly where our investment can lever in UK or other sources of funding
- Improving the accessibility and safety of stations and services, particularly where our investment can lever in UK or other sources of funding.

The specific interventions identified in the Welsh Government National Transport Plan – draft are set out in [Tables A, B and C](#)

Table A: Welsh Government Priorities - Committed schemes

Intervention	Rationale	Timing
<p>Mid Tier Access for All programme: Station accessibility upgrades (station improvement) at Radyr, Llandaf, Ystrad Mynach, Machynlleth and Chirk</p> <p>Easy access installation programme for small rural stations across Wales to provide wheelchair access by use of on-train ramps.</p> <p>Funded through Welsh Government and DfT Access for All programme.</p>	<p>Rail use has increased and there is potential for further growth. There is a need to focus on improving connectivity and accessibility between communities and key employment centres, particularly for areas where accessibility is generally poor and where car ownership is low. There is a need to ensure that people can access the rail network through physical accessibility improvements.</p>	<p>Short term – being delivered during Control Period (CP5).</p>
<p>Station Improvement Programme (NSIP+): Station improvements at Aberystwyth, Rhyl, Ystrad Mynach, Pontypridd and Port Talbot Parkway.</p> <p>Funded through Welsh Government (Transport and Regeneration), ERDF, Network Rail, Arriva Trains Wales.</p>		
<p>Line extension and new station at Ebbw Vale Town.</p> <p>Funded by Welsh Government.</p>		
<p>Maesteg Branch frequency Enhancement.</p> <p>Funded by Welsh Government.</p>		
<p>Ebbw Vale line frequency enhancement (part of Phase 1 Metro).</p> <p>Funded by Welsh Government.</p>		
<p>North South journey time/capacity Improvement project.</p> <p>Funded through Welsh Government.</p>		

Table B: Welsh Government Priorities - Rail Services

Intervention	Rationale	Timing
<p>Manage the current franchise including:</p> <ul style="list-style-type: none"> - Ensuring the contract is managed effectively - Introduction of new services on the Cambrian Main Line and Heart of Wales Line <p>- A review of currently proposed service enhancements:</p> <ul style="list-style-type: none"> • Additional carriages to peak time services to Caerphilly following completion of Cardiff Area Signalling Renewal (CASR) in 2015 • Introduce additional services on the lines from Pontypridd and Caerphilly to Cardiff following completion of CASR in 2015 • Introduce additional services on the Vale of Glamorgan line following completion of CASR in 2015 • Extend the half-hourly service from Maesteg to Cardiff and Brackla Station following completion of CASR in 2015. 	<p>£177 million spent on the franchise (including additional services above the original specification) in 2013/14.</p> <p>National Rail Passenger Survey shows overall satisfaction with Arriva Trains Wales has improved since the franchise began (83% in Spring 2014). In 2013-14, Arriva Trains Wales's average punctuality was 93.1%. The proportion of passengers satisfied with punctuality/reliability in the Spring 2014 wave of the National Passenger Survey was 82%.</p>	<p>Short term.</p>
<p>Prepare for the next franchise to be in a position to let the franchise:</p> <ul style="list-style-type: none"> - Establish the policy framework within which the franchise will be let - Identify appropriate service frequencies and identify any additional services that should be included - Develop commercial strategy, informed by modelling work - Consider possible role of alliancing. 	<p>Rail use for travel to work is generally low. Recent increases in rail use indicate potential for further growth.</p> <p>There is a need to focus on improving connectivity and accessibility between communities and key employment centres, particularly for areas where accessibility is generally poor and where car ownership is low.</p>	<p>Short to medium term.</p>

Table C: Welsh Government Priorities - Future priorities

Intervention	Rationale	Timing
Contribute to Network Rail's Long Term Planning Process (LTPP) and the development of an ambitious Welsh Route Strategy.	Rail use has increased and there is potential for further growth. There is a need to focus on improving connectivity and accessibility between communities and key employment centres, particularly for areas where accessibility is generally poor and where car ownership is low.	Short term.
Develop assessment criteria and, using those criteria, a prioritised list of station improvement proposals to draw down funding from relevant HLOS specific funds (as rail is non-devolved). Continue to develop the following station schemes, subject to the business case and necessary consents: - Cardiff Central - Llanelli (Access for all – funding allocated) - Cathays (Access for all - allocated) - Taffs Well – accessibility upgrade and station improvement planned - Flint – accessibility upgrade undergoing feasibility study.	Rail use for travel to work is generally low. Recent increases in rail use indicate potential for further growth.	Short term.
Develop assessment criteria and, using those criteria, a prioritised list of new station proposals for further consideration (in relation to securing funding from the rail industry). The following stations will be assessed as part of this process: South East Wales - Roath Park/ Wedal Road, Crwys Road, Gabalfa, Ely Mill/ Victoria Park, Caerleon, Llanwern, Newport West (on Ebbw Line), Crumlin, St Mellons, Newport Road/Rover Way, Brackla, St Fagans, Magor. South West Wales - Templeton, St Clears, Cockett, Landore. Mid Wales - Bow Street, Carno, Howey. North Wales - Broughton, North Wrexham, Deeside Industrial Park/ Northern Gateway (as alternative to upgraded Hawarden Bridge Station), South Wrexham, Llangefni.		Short term.
Identify and prioritise opportunities to improve efficiency or capacity on the rail network and draw down HLOS specific funds through: - Level crossing closures - Line speed improvements.	Will enable journey time improvements which may enable additional services and, potentially increase patronage, and enhance rail safety.	Short term.
Where appropriate, identify other priorities for investment in rail in Wales and bring those priorities to the attention of the UK Government given that rail infrastructure is not devolved: - North Wales rail modernisation including electrification - Upgrade of the Relief Lines from Severn Tunnel to mainline standard - Other priorities to be identified.	Rail use for travel to work is generally low. Recent increases in rail use indicate potential for further growth. There is a need to focus on improving connectivity and accessibility between communities and key employment centres, particularly for areas where accessibility is generally poor and where car ownership is low. The lack of viable and affordable alternatives to the car to access key employment sites and other services has been identified in the work of the Ministerial Task Force on North Wales Transport.	Short to medium term.

SEWTA

SEWTA's South East Wales Regional Transport Plan, published in March 2010, was developed jointly by the ten constituent county authorities of SEWTA:

- Blaenau Gwent
- Bridgend
- Caerphilly
- Cardiff
- Merthyr Tydfil

- Monmouthshire
- Newport
- Rhondda Cynon Taf
- Torfaen
- Vale of Glamorgan.

The SEWTA Regional Transport Plan published in March 2010 set out the following priorities specifically for rail set out in [Table D](#).

Table D: Sewta priorities	
SEWTA Project Description	Comment
A programme of improvements to station facilities, access, information, safety and security, car parking and rail link bus services.	A range of projects have already been delivered and other schemes are being developed/in delivery through the National Station Improvement Programme (NSIP).
Capacity improvements (including signalling and passing loop), to enable a half-hourly service to operate between Rhymney and Cardiff, and a new station at Energlyn.	Works delivered.
Capacity improvements (including signalling and passing loop), between Maesteg and Bridgend to enable a half-hourly service to operate between Maesteg and Cardiff with a new station at Brackla.	Scheme currently being developed to GRIP 4 although remit from Welsh Government does not consider new station at Brackla.
A package of track and resignalling improvements (including new crossovers) around the Newport area being undertaken by Network Rail.	Works delivered.
A package of track and resignalling improvements around the Cardiff area (including new crossovers and new platforms at Cardiff Central and Cardiff Queen Street) being undertaken by Network Rail.	Works currently being delivered.
Capacity improvements building upon Network Rail's CASR scheme to enable an additional service every hour between Cardiff and Caerphilly and between Cardiff and Pontypridd.	Works currently being delivered.
Additional Valley Lines peak carriages and lengthening of trains on existing well used services.	Welsh Route Study assesses passenger capacity on the Valley lines networks aligned to future electric passenger rolling stock options (see 4.1.2).
Introduction of further additional services every hour between Cardiff and Caerphilly.	Infrastructure being delivered in CP5 to facilitate this requirement.
Introduction of further additional services every hour between Cardiff and Pontypridd.	Infrastructure being delivered in CP5 to facilitate this requirement.
Capacity improvements building upon Network Rail's NASR scheme (including signalling, new crossovers, Relief Line speed increases, turnback facility and a new station (without Park & Ride at Caerleon) to enable an additional half-hourly local service between Abergavenny and Cardiff.	Conditional Output CO5 (see 6.2.5) considers additional capacity along the Marches route and the 2043 Indicative Train Service Specification includes this requirement, although no assessment has been made with regard to the aspirations for a new station at Caerleon.
Capacity improvements building upon the CASR scheme (including signalling, new crossovers and turnback facilities at Barry) to enable an additional service every hour to operate on the Vale of Glamorgan Line.	Works currently being delivered.

Table D: Sewta priorities

SEWTA Project Description	Comment
Severn Tunnel Junction Station improvements, including Park & Ride extension, building upon the fourth platform funded as part of the NASR scheme, and station improvements funded by Network Rail's National Station Improvement Programme.	The Welsh Route Study notes this aspiration and the opportunity to develop Severn Tunnel Junction Station as a Park & Ride facility given its close proximity to the M4 motorway.
New stations at Llanwern (with Park & Ride), St Mellons and Coedkernew facilitated by the Relief Line speed increases associated with the NASR scheme.	Options for raising Relief Line speed on the South Wales Main Line are considered in the Welsh Route Study as options to increase capacity and reduce journey time.
Provision of an hourly local service between Gloucester and Cardiff.	Welsh Route Study assesses the network capability for more services along this route (see Section 6.2.2).
Capacity improvements building upon the NASR scheme including Relief Line speed increases and turnback facility to enable an additional hourly local service between Chepstow and Cardiff.	Welsh Route Study assesses the network capability for more services along this route (see Section 6.2.2) and also considers the opportunity to raise Relief Line speeds between Severn Tunnel Junction and Cardiff Central.
Extension of existing line from Ebbw Vale Parkway to new station at Ebbw Vale Town.	Works currently being delivered.
Ebbw Vale – Newport additional services.	Welsh Government is funding development works that are assessing what additional infrastructure is required to deliver service frequency enhancements on the route with some services potentially serving Newport (see Conditional Output CO33).
Capacity improvements building upon existing service between Ebbw Vale Parkway and Cardiff, and NASR, including signalling, new crossovers and passing loop, to enable additional hourly local service between Ebbw Vale Town and Newport.	The Welsh Route Study assesses how future services from Ebbw Vale might be accommodated on the route between Ebbw Vale and Newport (see Conditional Output CO33).
Gaer Junction reinstatement scheme being progressed by the Welsh Government and Network Rail, to allow for the proposed Ebbw Vale Town to Newport service to operate in the future.	Works delivered.
Building on other Ebbw Vale Railway schemes, to look at a new line between Aberbeeg and Abertillery, and additional new stations on main branch at Cwm, Crumlin, Pye Corner and Newport West Central.	The Welsh Government is funding development works that are assessing what additional infrastructure is required to deliver service frequency enhancements on the route with some services potentially serving Newport. This work has also modelled the impact of an additional future station at Crumlin. Consideration is also being given as part of this to potential future aspirations to re-open the line from Aberbeeg Junction to Abertillery. The aspiration to run passenger services to Abertillery is recognised in the 2043 ITSS as the development work for enhancing service frequency on the Ebbw Vale line considers timetable options for extension of some services to Abertillery. A new station at Pye Corner opened in December 2014.
Reinstatement of former freight line for passenger use, with new stations at Beddau, Gwaun Meisgyn, Llantrisant and Cross Inn to enable a half-hourly service to operate.	No work has progressed on this proposal.
The scheme saw the construction of a new Abercynon station, closure of the old Abercynon North station and construction of a passing loop on the Merthyr Vale Line, to allow for a four train an hour frequency from Abercynon and half hourly train service from Merthyr Tydfil.	Scheme delivered.
Additional platform provision at Pontypridd, Caerphilly and Barry.	All to be delivered in CP5.
Rolling Stock refurbishment Refurbishment or replacement of existing Valley Lines Pacer and Sprinter fleet, to also take into account possible future electrification of network.	Electrification of parts of the network in CP5 and early CP6 will see electric rolling stock cascaded either cascaded from other parts of the national rail network or newly procured.

SWWITCH

SWWITCH's South West Wales Regional Transport Plan, published in December 2013, represents the views of the four constituent authorities of SWWITCH:

- Carmarthenshire
- Neath Port Talbot
- Pembrokeshire
- Swansea.

The SWWITCH Rail Strategy sets out a number of short, medium and longer term proposals as follows in [Tables E, F and G](#) respectively..

Table E: SWWITCH Short Term Proposals	
SWWITCH Short Term Proposals	Comment
Package of station improvements is recommended with an audit of facilities required to identify potential gaps.	Network Rail will continue to work with Welsh Government and local authorities to develop priorities for station improvements.
A desire for local authorities to work collaboratively with Network Rail to deliver a package of level crossing improvements between Tenby and Pembroke Dock where these will assist in improving journey times by the removal of low speed approach and crossing speeds for trains on this route.	Network Rail supports this approach in its objectives to eliminate the single biggest risk that level crossings pose to the safe operation of the rail network.
Retention of extra Fishguard trains funded by Welsh Government for a trial period – Welsh Government has now committed funding for these additional services to the end of the current Wales & Borders franchise and has noted the positive impact that these additional services have had in improving connectivity to social infrastructure such as hospitals, and in the positive economic benefits reported by businesses as a result of the extra trains helped attract visitors to the area.	The Welsh Route Study assesses how future additional services may be accommodated to destinations in South West Wales on the network against Conditional Output CO37.
Deliver a package of infrastructure works to boost capacity at Swansea station, plus signalling works at Whitland / Carmarthen.	Network Rail's proposals to re-signal the Port Talbot West area which includes Swansea, includes provision for future additional capacity by improving signalling flexibility. The Welsh Route Study assesses how future additional services may be accommodated to destinations in South West Wales on the network against Conditional Output CO37, which will review any potential future constraints in the Carmarthen and Whitland areas.
Examine the feasibility of using Landore depot once High Speed Trains (HSTs) cease to use the site from 2018, to maintain diesel trains that serve South West Wales.	Network Rail will continue to work with Welsh Government to understand these requirements which will be an important consideration for the new franchise, however, the work to re-signal this area through the Port Talbot resignalling scheme does assume that Llandore Depot will be required in the longer term.
Examine the scope to procure a small number of additional diesel units which are cascaded following electrification schemes in North West England, to help address short term timetable gaps.	

Table F: SWWITCH Medium Term Proposals	
SWWITCH Medium Term Proposals	Comment
Improve frequency of the stopping service between Cardiff Central and Swansea to improve connectivity.	The Welsh Route Study assesses how future additional services may be accommodated on the network against Conditional Output CO31.
Introduce an hourly service between Milford Haven and Swansea which provides connections into Swansea – London Paddington services at Swansea.	The Welsh Route Study assesses how future additional services may be accommodated on the network against Conditional Output CO37.
Improved journey times on the Pembroke Dock line with services timed to connect with future electric services between Swansea and Bristol.	This is closely aligned to the short term proposal set out in Section 5.1.5 . The removal of low speed approach and crossing speeds at level crossings will improve overall journey time along this route.
Replace current service pattern with a two-hourly service between Fishguard and Swansea connecting into /out off future electric services between Swansea and Bristol.	The Welsh Route Study assesses how future additional services may be accommodated to destinations in South West Wales on the network against Conditional Output CO37.
Replace current services with an hourly fast service to Carmarthen connecting into /out off future electric services between Swansea and Bristol.	The Welsh Route Study assesses how future additional services may be accommodated to destinations in South West Wales on the network against Conditional Output CO37.
Supplement existing Heart of Wales Line services with additional semi-fast trains between Llandoverly and Swansea serving the principal stations to deliver faster journey times and offer earlier / later trains to /from Swansea.	The Welsh Route Study identified a Conditional Output (CO38) to improve morning peak arrival time for Heart of Wales line service to Swansea. It is considered that this conditional output will be met by the recent announcement by Welsh Government, which confirms funding being allocated for additional services on the Heart of Wales line commencing in May 2015, that will deliver morning peak arrivals and peak evening departures from both ends of the Heart of Wales line (Swansea and Shrewsbury).
Delivery of a new station serving St Clears subject to achieving forecast high growth scenario.	

Table G: SWWITCH Long Term Proposals	
SWWITCH Long Term Proposals	Comment
Improved surface access links to Heathrow Airport with passenger service provision to / from South Wales.	Conditional Output CO41 sets out proposals for improving connectivity to airports and Section 4.4.1.3 specifically considers improving connectivity to Heathrow Airport.
Support the construction of a new alignment to supplement the Great Western Main Line to support future growth if capacity is absorbed following delivery of the new electric timetable in 2018.	Section 6.2.2 considers the long term connectivity requirements out to 2043 and this is reflected in Conditional Output CO11.
Assuming a business case for a fixed link between South West Wales and southern Ireland is identified, stakeholders will need to lobby for a support of infrastructure improvements to support growth in freight traffic.	
Support the incremental electrification of the rail network both west of Swansea and east of Newport (for example, via Shrewsbury, Chepstow or Taunton) which may enable a more comprehensive service pattern to/from South Wales.	

TraCC

TraCC's Regional Rail Strategy and Actions, published in January 2013, represents the views of the counties of Ceredigion, Powys and Gwynedd and includes parts of the Snowdonia and Brecon Beacons National Parks.

The actions identified in the strategy are detailed in [Table H](#).

Table H: TraCC Actions	
TraCC Actions	Comment
TraCC seeks the introduction of an hourly service on the Cambrian Main Line in accordance with the commitment of the Welsh Government in the prioritised National Transport Plan.	Section 6.2.7 considers the long term connectivity requirements out to 2043 and this is reflected in Conditional Output CO39. A recent announcement by Welsh Government, has confirmed funding being allocated for additional services between Aberystwyth and Shrewsbury commencing in May 2015, providing additional morning peak services into Shrewsbury and return evening peak services out of Shrewsbury.
TraCC seeks an improved service frequency on the Heart of Wales Line and will support investigations into ways of improving the level of service and operational model to maximise the benefits of the line in a situation of constrained resources.	Section 5.1.6 considers the need to improve commuting from the Heart of Wales line into Swansea and this is reflected in Conditional Output CO38 which it is considered will be met by the recent announcement by Welsh Government, which confirms funding being allocated for additional services on the Heart of Wales line commencing in May 2015, that will deliver morning peak arrivals and peak evening departures from both ends of the Heart of Wales line (Swansea and Shrewsbury). It is also noted that the Heart of Wales Line Forum will be reporting the findings of their study into how the Heart of Wales Line service might be enhanced, to the Welsh Government Minister for Economy, Science and Transport in December 2014.
TraCC will work with the Rail Industry to look at options for enhancing service frequencies on the Cambrian Coast Line.	
TraCC will seek a replacement in rolling stock within the new rail franchise, to ensure the rail services are modern, attractive and accessible.	
TraCC is supportive of new stations where there is a positive business case that can be demonstrated. TraCC considers the new stations at Carno and Bow Street to be regional priorities.	
TraCC will give priority to supporting improvements to those crossings identified by Network Rail as highest risk, promoted as recreational route crossings and those crossings which also present issues for the operations and safety of the regional core highway network.	
TraCC supports the progression towards the electrification of railways in Wales and into England and will engage in Rail Industry discussions to ensure the region benefits from and is not disadvantaged by electrification programmes. TraCC seeks consideration of electrification of the Cambrian Main Line in the long term.	
TraCC expect that the Welsh Government take forward feasibility and business case examinations for potential re-opening of rail lines as they emerge.	
The Blaenau Ffestiniog to Trawsfynydd line should be protected for future rail use.	

Table H: TraCC Actions	
TraCC Actions	Comment
TraCC would like to engage with Network Rail regarding the programme for renewal of railway structures and will examine opportunities to align rail schemes with the wider regional transport agenda. TraCC will seek where possible improvements to active travel and highways to add value to alongside rail infrastructure measures.	An example of this collaboration can be demonstrated by the works undertaken by Gwynedd CC to deliver a new combined road and rail bridge at Pont Briewt during 2014.
TraCC expects Network Rail to find a solution to provide ERTMS enabled heritage/ excursion trains.	
TraCC will respond positively to proposals for the location of potential freight facilities in Mid Wales. However, for any realistic chance of the Mid Wales railway lines carrying goods/ freight, there will need to be a sound business case and proposals must be market-led.	
TraCC will prioritise the provision of real time information for bus services at a number of rail stations with bus service interchange.	
TraCC fully supports the concept of the integrated ticketing for bus and rail and urges the Welsh Government to ensure implementation is achieved at the earliest opportunity.	
In developing the Regional Bus and Community Transport Network Strategy, TraCC will review and prioritise the connection of bus services to rail timetables where possible and appropriate, to minimise waiting times and make public transport more attractive.	
TraCC will engage with rail partnership groups to identify a model that is best suited for more effectively and consistently communicating Mid Wales rail priorities and will seek to provide sufficient officer resource to support the regional role.	
TraCC will continue to support initiatives to market and promote rail services.	

TAITH

TAITH published a North Wales Regional Transport Plan in September 2009 developed jointly by the constituent authorities of Taith, Anglesey, Conwy, Denbighshire, Flintshire, Gwynedd and Wrexham councils.

The key proposals identified in the North Wales Regional Transport Plan are summarised in [Table I](#).

In June 2013, the North East Wales Integrated Transport Task Force reported to the Minister for Economy, Science and Transport. The Minister commissioned the Task

Force to drive forward the development of an integrated transport system in North East Wales. The Task Force, supported by the Welsh Government and Taith, was drawn from local authorities in North East Wales, North West England and representatives from industry, business, public transport providers and operators, third sector and various passenger / user groups.

In essence, the Task Force was tasked with developing recommendations to maintain and improve existing connectivity within North East Wales, at the same time as ensuring wider cross-border links to/from North West England, in particular Chester West & Chester and the Wirral, with whom economic geographies significantly overlap. The overarching objective established for the

Task Force was to develop the transport system in North East Wales so that it

- develops and underpins jobs and growth in the economy
- promotes social inclusion, equality and the reduction of poverty
- protects the environment.

The key proposals identified by the North East Wales Integrated Task Force are set out in [Table J](#).

Table I: TAITH key proposals

North Wales Regional Transport Plan proposals	Comment
Major infrastructure improvements and line speed improvements across North Wales to improve rail travel.	See Section 5.1.8 relating to the Welsh Governments priority to modernise the North Wales Coast Main Line.
Frequency enhancement to half-hourly service on the Wrexham to Bidston Line optimising connections with the North Wales Coast Line at Shotton.	Conditional Output CO40 sets out the requirement to provide the rail offering to the Deeside area and the Welsh Route Study assesses how additional frequency of services can be accommodated on this part of the network.
Extension of Llandudno – Manchester service to Manchester Airport.	See Conditional Output CO41 relating to Manchester International Airport connectivity.
Improve journey time on North Wales – Manchester services.	See Conditional Output CO22 relating to North Wales connectivity.
New stations.	
Improved car parking at stations.	
Increase number of freight services in North Wales associated with removal of freight gauge constraints.	The Freight Market Study set out the projected freight requirements out to 2043 which are reflected in the Welsh Route Study.

Table J: North East Wales Integrated Task Force proposals	
North East Wales Integrated Task Force proposals	Comment
Frequency enhancement to half-hourly service on the Wrexham to Bidston Line.	Conditional Output CO40 sets out the requirement to provide the rail offering to the Deeside area and the Welsh Route Study assesses how additional frequency of services can be accommodated on this part of the network.
Extension of Llandudno – Manchester service to Manchester Airport.	See Conditional Output CO41 relating to Manchester International Airport connectivity.
Enhanced station at Hawarden Bridge with upgraded access arrangements to Deeside Industrial Park / Enterprise Zone.	Conditional Output CO40 sets out the requirement to provide the rail offering to the Deeside area and the Welsh Route Study assesses how additional frequency of services can be accommodated on this part of the network.
Station Enhancement at Shotton Interchange (creation of a bus hub).	See Section 6.2.10.3 .
New station at Deeside Industrial Park / Northern Gateway (subject to future strategy relating to Hawarden Bridge).	
New station north of Wrexham on the Shrewsbury to Chester Line.	
New station at Queensferry and / or Airbus / Saltney (Mold Junction).	Conditional Output CO40 sets out the requirement to provide the rail offering to the Deeside area and the Welsh Route Study assess opportunities for improved access via a new station on the North Wales Coast Main Line.
Improved car parking at Rail Stations.	
Following enhancement of infrastructure along the route, provide options to provide frequency enhancements between Chester and Wrexham.	Section 4.3 sets out a range of Conditional Outputs relating to improving connectivity on routes via Wrexham and Chester.
Enhancement of Halton Chord to enable direct services to Liverpool South / Liverpool from the study area.	UK Government recently announced the funding of the capital costs associated with the enhancement of this rail link which would enable direct rail services to operate between Liverpool Lime Street, Liverpool South Parkway and Chester via Frodsham Junction.
Extension of London - Chester services to Bangor / Holyhead.	Conditional Output CO21 sets out the output the industry aspires to deliver by 2043 and the Welsh Route Study assess how this might be delivered in the future.
Service enhancements following outcomes of Rail Modernisation. Schemes may include service changes on the North Wales Coast Line, including Fast Llandudno-Manchester Airport service, splitting and joining at Chester with Wrexham portion and Rhyl - Chester (with possible extension to Crewe) local shuttle.	Section 4.3 sets out a range of Conditional Outputs relating to improving connectivity on the North Wales Coast Main Line.

Merseytravel

A part of the development of the Welsh Route Study, Network Rail has engaged with Merseytravel, the passenger transport executive responsible for the coordination of public transport in the Liverpool City Region. Merseytravel are keen to see the introduction of direct services between Liverpool and North Wales via an enhanced Halton Chord (for which the UK Government recently announced the funding of the capital costs associated with the enhancement of this rail link), and have been working closely with Welsh Government to develop options for services that would provide direct links between these regions. This will help support the economies of Merseyside and North East Wales whose economies work closely together.

Heart of Wales Line Forum

Welsh Government has provided funding to the Heart of Wales Line Forum to assess the feasibility of operating more frequent services along the route to provide better access to employment and social infrastructure and promote tourism within the region through which this line passes. The route is a Community Rail Partnership and the Heart of Wales Line Forum actively promote the line and their report to the Welsh Minister for Economy, Science and Transport was published in December 2014.

Marches Local Enterprise Partnership (LEP)

A part of the development of the Welsh Route Study, Network Rail has engaged with the Marches Local Enterprise Partnership, which has undertaken some work to assess capacity on the rail network on the Marches Line. The Welsh Route Study has assessed future passenger growth and proposed interventions in [Section 5.1.7](#).

Community Rail Partnerships (CRPs)

Network Rail will continue to engage and support the work of CRPs in Wales and the border counties in identifying where improvements can be made to the rail network which will promote and support greater use of rail services on CRP routes.

Herefordshire County Council

Herefordshire County Council are developing proposals for a short rail link south of Hereford to Rotherwas. Network Rail has provided indicative costs for this rail link and London Midland Train Operating company has provided details of how their services from Birmingham might be extended to Rotherwas. Currently this proposal has no committed funding.

Traws link Cymru

Traws Link Cymru has aspirations to re-open the rail route between Aberystwyth and Carmarthen. This route was closed during 1964/65. Currently this proposal has no committed funding.

Glossary	
Term	Meaning
AFC	Anticipated Final Cost. A cost provided in the Route study to allow options to be compared, composed of the Point Estimate plus Risk (also known as a Proposal Estimate).
CASR	Cardiff Area Signalling Renewal. A signalling renewal to increase capacity in the Cardiff area.
CRP	Community Rail Partnerships. The support of local railways by local organisations.
CP4	Control Period 4. This is the funding period from 2009-2014.
CP5	Control Period 5. This is the funding period from 2014 - 2019.
CP6	Control Period 6. This is the funding period from 2019 - 2024.
DFT	Department for Transport.
DECC	Department of Energy and Climate Change.
Dc	Direct Current. Specifically 750 volt 3rd Rail electrification.
EMU	Electric Multiple Units. A train using an electrical power source.
ESI	Electricity Supply Industry.
ERTMS	European Rail Traffic Management System. A system for managing train movements using ETCS to signal trains and GSMR to communicate with trains.
ETCS	European Train Control System. A new signalling control and train protection system currently being installed.
GWML	Great Western Main Line.
GMPTE	Greater Manchester Passenger Transport Executive.
GVA	Gross Value Added.
HLOS	High Level Output Specification.
HS2	High Speed Two. The planned High speed link between London, Birmingham and the north.
HST	High Speed Train.
ITSS	Indicative Train Service Specification. A list of possible or proposed train services including characteristics such as origin, destination and routeing.
IIP	Initial Industry Plan. A plan to examine the key choices and options facing funders in specifying the future outputs of the railway and the level of funding required.
IEP	Intercity Express Programme. A series of linked projects to introduce new Super Express Trains (SETs), associated with depots infrastructure on the Western Route and elsewhere.
LEP	Local Enterprise Partnership. A partnership between local authorities and businesses.
LTPP	Long Term Planning Process.
MoD	Ministry of Defence.
NSIP	National Station Improvement Programme. A series of projects to improve railway stations.
NASR	Newport Area Signal Renewal. A signalling renewal to increase capacity in the Newport area.
ORR	Office of Rail Regulation. The safety and economic regulator for the rail industry in Great Britain.
PGS	Prospering in Global Stability. High economic growth forecast scenario.

Glossary	
Term	Meaning
RUS	Route Utilisation Study. A report which considers the future development of the railway in a particular area, or one aspect of its development in depth. This are being phased out by Route studies in the Long Term Planning Process.
SEWTA	South East Wales Transport Consortia. An alliance of 10 local authorities in South East Wales those were previously involved in the development of regional transport strategy and planning.
SWML	South Wales Main Line. The railway line running between Severn Tunnel and Swansea.
SWWITCH	South West Wales Integrated Transport Consortia. An alliance of four local authorities in South West Wales those were previously involved in the development of regional transport strategy and planning.
SII	Struggling In Isolation. Low economic growth forecast scenario.
SDL	Swansea District Line. A railway running predominately through Northern Swansea which is mainly used by freight traffic.
STJ	Severn Tunnel Junction.
TAITH	An Alliance of six North Wales local authorities which were previously involved in the development of regional transport strategy and planning.
TraCC	Trafnidiaeth Canolbarth Cymru. An alliance of three Mid Wales local authorities which were previously involved in the development of regional transport strategy and planning.
Tph	Number of trains per hour.
VLE	Valley Lines Electrification. The Railways that serve the Welsh Valleys north of Cardiff, Newport and the Vale of Glamorgan.
WRCCA	Weather Resilience and Climate Change Adaptation.
WAG	Welsh Assembly Government. This is the devolved Government for Wales.

Network Rail

Floor 6
1 Eversholt Street
London
NW1 2DN

www.networkrail.co.uk