

Understanding IEEE 1451 – Networked Smart Transducer Interface Standard

Eugene Y. Song and Kang Lee

© iStockphoto.com

What Is a Smart Transducer?

Sensors and actuators are ubiquitous. They are used in a variety of applications that touch people's lives every day, ranging from industrial automation to environmental condition monitoring and control to intelligent transportation systems to homeland defense. So what is a transducer? A transducer is a device that converts energy from one form into another. The transducer may either be a sensor or an actuator. A sensor is a transducer that generates an electrical signal proportional to a physical, biological, or chemical parameter. An actuator is a transducer that accepts an electrical signal and takes a physical action. A smart transducer is the integration of an analog or digital sensor or actuator element, a processing unit, and a communication interface [1]. A smart transducer comprises a hardware or software device consisting of a small, compact unit containing a sensor or actuator element, a microcontroller, a communication controller and the associated software from signal conditioning, calibration, diagnostics, and communication [2].

Based on this premise, a smart transducer model is shown in Figure 1(a). It

consists of four parts: transducers (sensors and actuators), signal conditioning and data conversion, application processor, and network communication. The analog output of a sensor is conditioned and scaled (amplified), then converted to a digital format by an A/D converter. The digitized sensor signal can then be easily processed by a microprocessor using a digital application control algorithm. The measured or calculated parameters can be passed on to a host or monitoring system in a network by means of network communication protocols. In a reverse manner, an actuation command sent from a host via the network can be used to control an actuator.

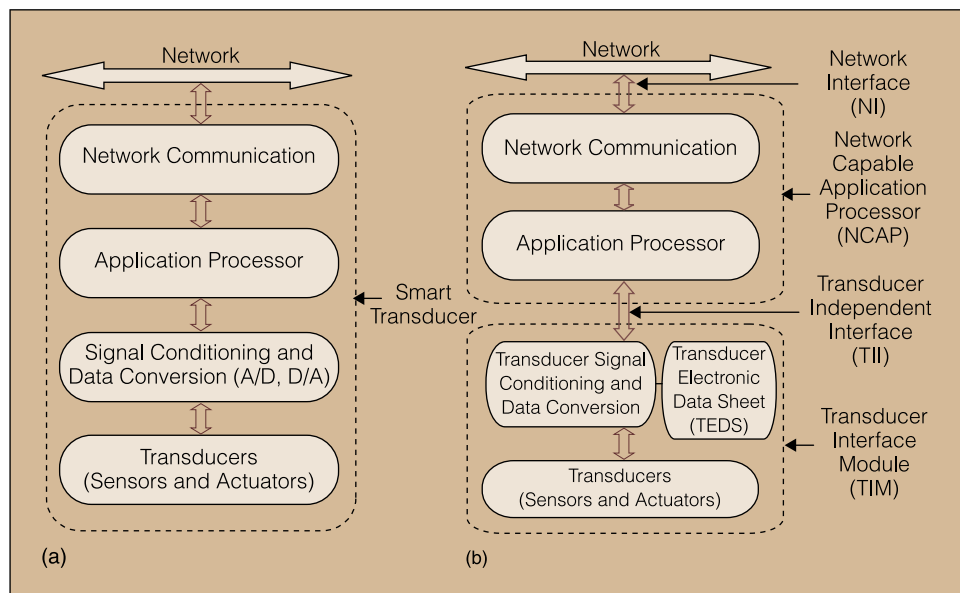

Fig. 1. (a) A smart transducer model; (b) This architecture adds TEDS and the system partition into NCAP and TIM, with a TII.

What Is an IEEE 1451 Smart Transducer?

In response to industry's need for a set of standardized sensor interfaces, the Institute of Electrical and Electronic Engineers (IEEE) Instrumentation and Measurement Society's Technical Committee on Sensor Technology has sponsored the development of a suite of smart transducer interface standards for sensors and actuators, known as the IEEE 1451. To go beyond the previous definitions, an IEEE 1451 smart transducer is defined as a smart transducer that provides functions beyond those necessary for generating a correct representation of a sensed or controlled quantity. This functionality typically simplifies the integration of the transducers into applications in a networked environment [3]. This means IEEE 1451 smart transducers would have capabilities for self-identification, self-description, self-diagnosis, self-calibration, location-awareness, time-awareness, data processing, reasoning, data fusion, alert notification (report signal), standard-based data formats, and communication protocols. Figure 1(b) shows the IEEE 1451 smart transducer architecture, which is quite similar to Figure 1(a). The difference is the addition of the Transducer Electronic Data Sheets (TEDS) and the partition of the system into two major components—a Network Capable Application Processor (NCAP), Transducer Interface Module (TIM), and a transducer independent interface (TII) between the NCAP and TIM. The NCAP, a network node, performs application processing and network communication function, while the TIM consists of a transducer signal conditioning and data conversion and a number of sensors and actuators, with a combination of up to 255 devices. This is very useful for working with large sensor arrays such as Micro-Electro-Mechanical-System (MEMS) devices or a large mix of sensors and actuators. The transducer independent interface defines a communication medium and a protocol for transferring sensor information. This interface provides a set of operations, such as read, write, read and write message, read and write responses, etc. The network interface defines a network communication protocol for NCAP communications to the network.

Other than the specification of the communication interface, the other key feature of an IEEE 1451 smart transducer is the specification of the standardized TEDS and their formats. The TEDS attached to the transducer is like an identification card carried by a person. It stores manufacture-related information for the transducer(s), such as manufacturer identification, measurement range, accuracy, and calibration data, similar to the information contained in the transducer data sheets normally provided by the manufacturer. The TEDS could be stored in some form of electrically erasable programmable ROM if the contents never change, or the changeable portions of the TEDS

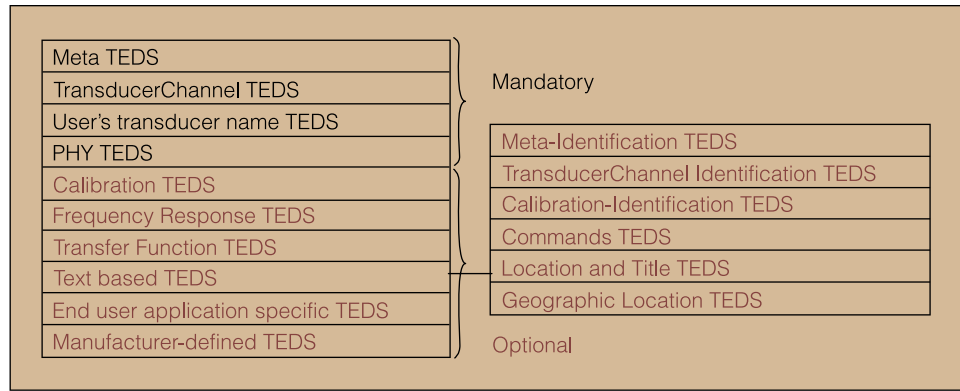

Fig. 2. IEEE 1451.0 TEDS.

could be in the RAM of the TIM. As defined in the IEEE 1451.0 standard, four kinds of TEDS are mandatory. The others are optional. The required TEDS are shown in the Figure 2:

- MetaTEDS,
- TransducerChannelTEDS,
- PHYTEDS, and
- UserTransducerNameTEDS.

Some of the optional TEDS are

- CalibrationTEDS,
- FrequencyResponseTEDS,
- TransferFunctionTEDS,
- TextTEDS, EndUserApplicationSpecificTEDS, and
- ManufacturerDefinedTEDS.

IEEE 1451 Family of Standards

What Is the Architecture of the IEEE 1451 Family of Standards?

The IEEE 1451, a family of Smart Transducer Interface Standards, defines a set of open, common, network-independent communication interfaces for connecting transducers (sensors or actuators) to microprocessors, instrumentation systems, and control/field networks [4]. The IEEE 1451 standard family provides a set of protocols for wired and wireless distributed monitoring and control applications. Figure 3 shows the architecture of the IEEE 1451 standards.

In the IEEE 1451 family, the IEEE 1451.0 standard defines a common set of commands for accessing sensors and actuators connected in various physical configurations, such as point-to-point, distributed multi-drop, and wireless configurations, to fulfill various application needs. There are three possible ways to access sensors and actuators in the TIM from a network. They are

- IEEE 1451.1,
- IEEE 1451.0 Hyper Text Transfer Protocol, and
- The proposed Smart Transducer Web Services [5].

The physical interfaces between the NCAP and TIM include the following:

- the point-to-point interface that meets the IEEE Standard 1451.2-1997,
- the distributed multi-drop interface that meets the IEEE Standard 1451.3-2003,

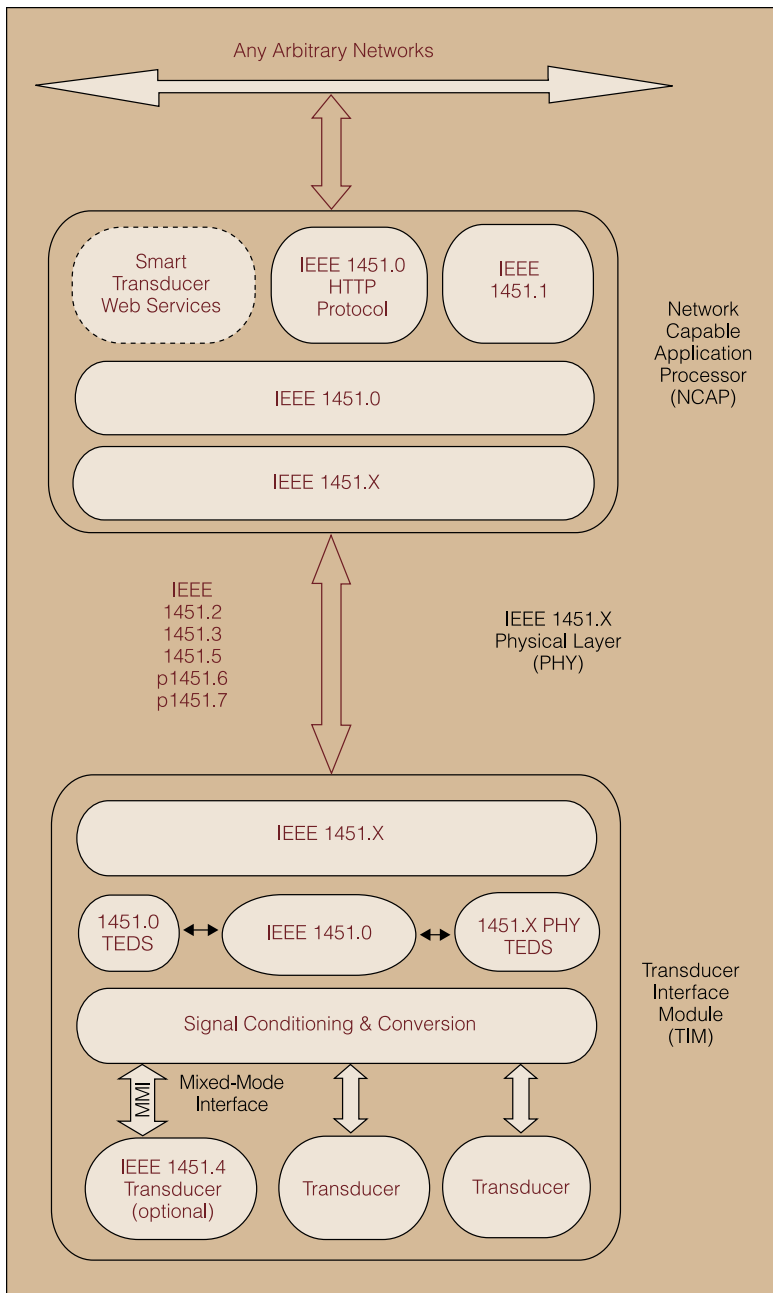

Fig. 3. Architecture of IEEE 1451 standards.

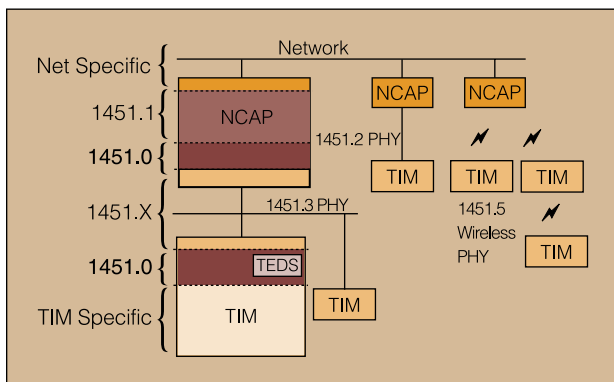

Fig. 4. Network access of IEEE 1451 wired and wireless transducers.

- the wireless interface that meets the IEEE Standard 1451.5-2007 (WiFi, Bluetooth, and ZigBee),
- the CANopen interface that meets the proposed IEEE P1451.6 standard, and
- The Radio Frequency Identification (RFID) interface that meets the proposed IEEE P1451.7 standard.

In general, the interfaces between transducers and signal conditioning and conversion circuits are not specified in the IEEE 1451 standards except the IEEE 1451.4, which specifies a low-level, mixed-mode interface for transducers. The IEEE 1451.4 defines a TEDS, but it deals with transducer signals in analog form. In order to operate in the IEEE 1451.0 environment, the IEEE 1451.4 TEDS needs to be converted to the IEEE 1451.0 TEDS, as shown in Figure 3.

Thus, the IEEE 1451.0 standard defines a unified interface for IEEE 1451 smart transducers [3]. The main goal of the IEEE 1451 is to allow the network access to standardized transducer data through a common set of interfaces, whether the transducers are connected to systems or networks via wired or wireless means. This is illustrated in Figure 4.

What Are the Elements of the IEEE 1451 Family of Standards?

IEEE 1451.0

The IEEE 1451.0 standard defines a set of common functionality, commands, and TEDS for the family of IEEE 1451 smart transducer interface standards [3]. This functionality will be independent of the physical communications media (1451.X) between the transducer and NCAP. It includes the basic functions to read and write to the transducers, to read and write TEDS, and to send configuration, control, and operation commands to the TIM. This makes it easy to add other proposed IEEE 1451.X physical layers to the family.

One of the goals of IEEE 1451.0 is to help achieve data-level interoperability for the IEEE 1451 family when multiple wired and wireless sensor networks are connected together.

IEEE 1451.1

The IEEE 1451.1 standard defines a common object model and interface specification for the components of a networked smart transducer [6]. The IEEE 1451.1 software architecture is defined by three models:

- A data model specifies the type and form of information communicated across the IEEE 1451.1 specified object interfaces for both local and remote communications;

- ▶ An object model specifies the software component types used to design and implement application systems. Basically the object model provides software building blocks for the application systems; and
- ▶ Two communication models define the syntax and the semantics of the software interfaces between a communication network and the application objects.

The IEEE 1451.1 standard is applicable to distributed measurement and control applications [7], [8]. It mainly focuses on the communications between NCAPs and between NCAPs and other nodes in the system.

IEEE 1451.2

The IEEE 1451.2 standard defines a transducers-to-NCAP interface and TEDS for point-to-point configurations. Transducers are part of a Smart Transducer Interface Module [9]. The original standard describes a communication layer based on the Serial Peripheral Interface, with additional hardware lines for flow control and timing resulting in a total of 10 lines for the interface. This standard is being revised to interface with IEEE 1451.0 and to support two popular serial interfaces: UART and Universal Serial Interface.

IEEE 1451.3

The IEEE 1451.3 standard defines a transducer-to-NCAP interface and TEDS using a multi-drop communication protocol [10]. It allows transducers to be arrayed as nodes, on a multi-drop transducer network, sharing a common pair of wires.

IEEE 1451.4

The IEEE 1451.4 standard defines a mixed-mode interface for analog transducers with analog and digital operating modes [11]. A TEDS was added to a traditional two-wire, constant current excited sensor containing a FET amplifier. The TEDS model was also refined to allow a bare minimum of pertinent data to be stored in a physically small memory device, as required by tiny sensors. Additional TEDS were defined for other sensor types as well, such as microphones and accelerometers. IEEE 1451.4 mainly focuses on adding the TEDS feature to legacy analog sensors. Upon power up, the TEDS of a transducer is sent to an instrumentation system via a one-wire digital interface. Then the interface is switched into analog operation and the same interface is used to carry the analog signals from the transducer to the instrumentation system.

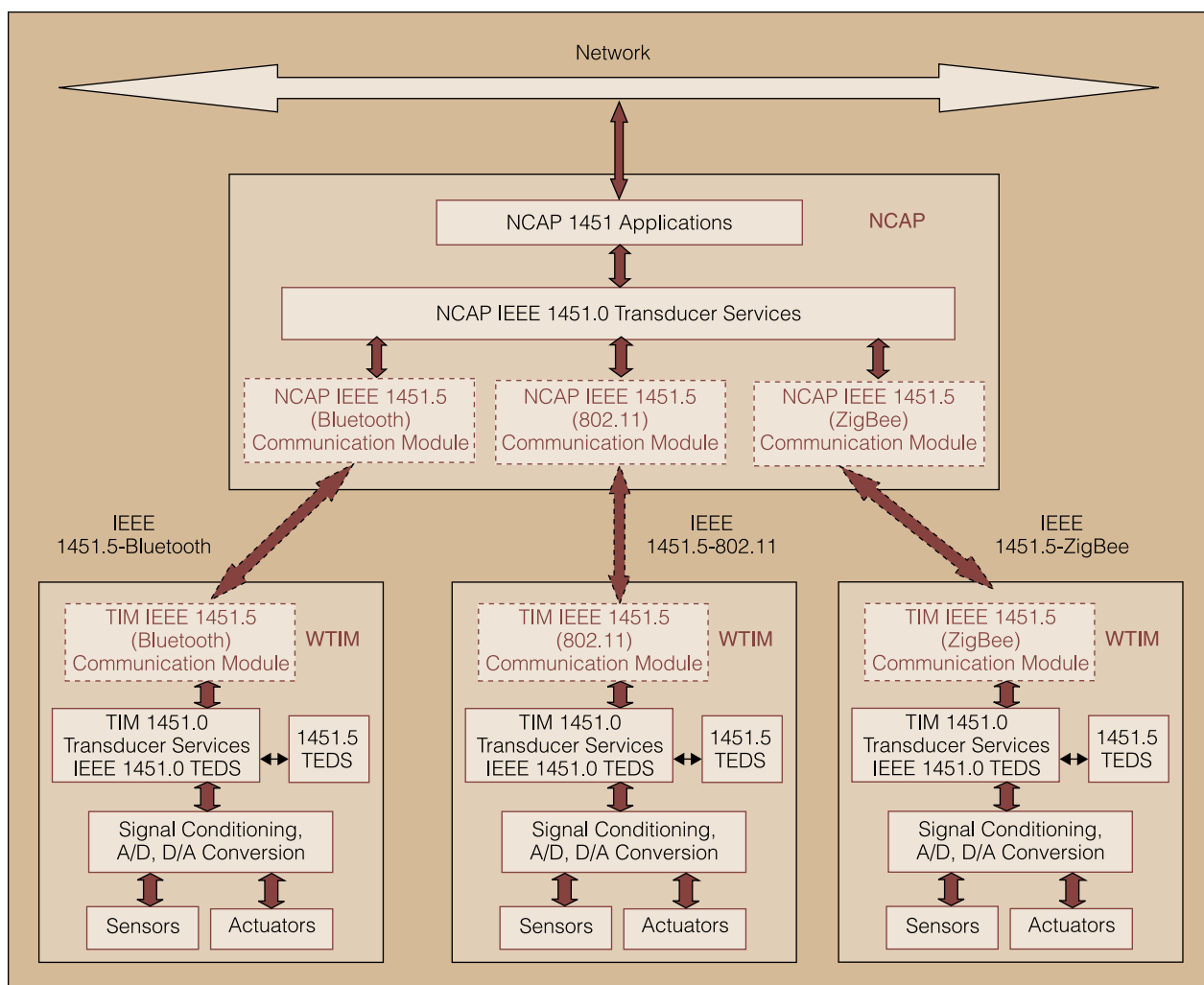

Fig. 5. IEEE 1451.5 architecture.

IEEE 1451.5

The IEEE 1451.5 standard defines a transducer-to-NCAP interface and TEDS for wireless transducers [12]. IEEE 1451.5 specifies radio-specific protocols for achieving this wireless interface. Wireless standards such as 802.11 (WiFi), 802.15.1 (Bluetooth), 802.15.4 (ZigBee), and 6LowPAN are adopted as the IEEE 1451.5 wireless interfaces [10]. Figure 5 shows the architecture of the IEEE 1451.5 wireless sensor network. The NCAP is a device that contains one or more wireless radios (802.11, Bluetooth, and ZigBee) and that can talk to one or more Wireless Transducer Interface Module (WTIM). Each WTIM contains one wireless radio (802.11, Bluetooth, or ZigBee), signal conditioning, A/D and/or digital-to-analog conversion, and the transducers. The NCAP can wirelessly talk to each WTIM using different wireless protocols, such as 802.11, Bluetooth, or ZigBee, and it may also be connected to an external network.

IEEE P1451.6

The IEEE P1451.6 standard defines a transducer-to-NCAP interface and TEDS using the high-speed CANopen network interface [13]. Both intrinsically safe and non-intrinsically safe applications are supported. It defines a mapping of the 1451 TEDS to the CANopen dictionary entries, as well as communication messages, process data, a configuration parameter, and diagnostic information. It adopts the CANopen device profile for measuring devices and closed-loop controllers.

IEEE P1451.7

The IEEE P1451.7 standard defines an interface and communication protocol between transducers and RFID systems [14]. By providing sensor information in supply-chain reporting, such as identifying products and tracking of their condition, the standard opens new opportunities for sensor and RFID system manufacturers.

What Benefits Will the IEEE 1451 Standard Bring?

The IEEE 1451 TEDS contain manufacturer-related information about the sensor, such as manufacturer name, sensor types, serial number, and calibration data and standardized data formats for the TEDS. The TEDS provide many benefits, as follows:

- They enable self-identification of sensors or actuators: A sensor or actuator equipped with the IEEE 1451 TEDS can identify and describe itself to the host or network by sending the TEDS information.
- They provide long-term self-documentation: The TEDS in the sensor can be updated and store information, such as the location of the sensor, recalibration date, repair records, and many maintenance-related data.
- They reduce human error: Automatic transfer of the TEDS data to the network or system eliminates the entering of sensor parameters by hand, which could induce errors.
- They ease field installation, upgrade, and maintenance of sensors: This helps to reduce the total-life cycle costs of sensor systems, because anyone can perform these tasks by simple “plug and play” of sensors.

• They provide plug-and-play capability: A TIM and NCAP that are built based on the IEEE 1451 standard are able to be connected with a standardized physical communications media and are able to operate without any change to the system software. There is no need for different drivers, profiles, or other software changes in order to provide basic operations of the transducers. Figure 6 shows the plug-and-play capability of IEEE 1451 sensor modules. It can be described as follows:

- TIMs from different sensor manufacturers can “plug and play” with NCAPs from a particular sensor network supplier through the same communication module.
- TIMs from a sensor manufacturer can “plug and play” with NCAPs supplied by different sensor or field network vendors through the same IEEE 1451 communication module.
- TIMs from different sensor manufacturers can be interoperable with NCAPs from different field network suppliers through the same IEEE 1451 communication module.
- NCAPs can “plug and play” with a wide variety of TIMs through a standard 1451.x interface. One NCAP can support a wide variety of sensors or actuators.

Using this partitioning approach, a migration path is provided to those sensor manufacturers who want to build TIMs with their sensors but who do not intend to become field network providers. Similarly, it applies to those sensor network builders who do not want to become sensor manufacturers. Of course, it is also possible for the vendors to combine both TIM and NCAP into a single module and sell it as an integrated, networked sensor. In this case the interface between the TIM and NCAP is hidden, but the integrated sensor is still IEEE 1451 compatible at the network level.

Applications of the IEEE 1451 Standard

The IEEE 1451 standard can be applied to many applications, for example, remote monitoring and actuating, distributed measurement and control, collaborative measurement and control, and web applications [15].

- Remote Monitoring and Actuating: When a NCAP is connected to a TIM equipped with sensors, the physical parameters being measured can be remotely monitored through the NCAP, which can send the resulting sensor data to the network or the Internet. Any monitoring sta-

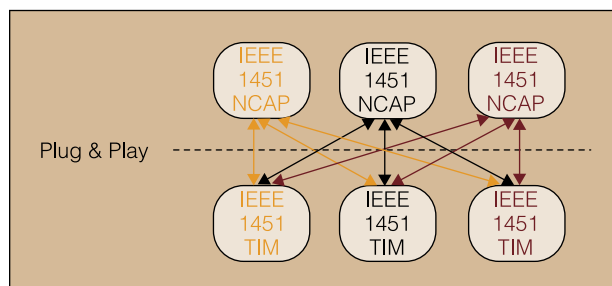

Fig. 6. Plug and play of sensor modules.

tion connected to the network or Internet can monitor the parameters. Remote actuating occurs when the NCAP is connected to a TIM consisting only of actuators. This provides a mechanism allowing the remote manipulation of the actuators in the network to which the NCAP is connected.

- Distributed Measurement and Control:** This occurs when a TIM with both sensor and actuator types is connected to a NCAP in a network. The TIM can perform local measurement and control functions as directed by an NCAP anywhere in the network or Internet.
- Collaborative Measurement and Control:** In this scenario, two or more NCAPs, each connected to a sensor TIM and an actuator TIM, communicate with one another to perform remote measurements and to control operations collaboratively.

Implementation Example Based on the IEEE 1451.0 and 1451.5 Standards

An implementation of a wireless monitoring system based on the IEEE 1451.0 and 1451.5 standards is shown in Figure 7. The system consists of a NCAP node and wireless TIM node [16]. The NCAP and wireless TIM are implemented on two laptop computers in Java language for ease of software testing. They can be easily implemented in embedded platforms. An IEEE 1451.2-based sensor module consisting of multiple sensors is attached to the wireless TIM computer via a serial port. The

NCAP communicates with the wireless TIM via an access point using the IEEE 802.11 wireless communications protocol. The communications between the NCAP and wireless TIM are implemented with the IEEE 1451.0 and 1451.5-802.11 protocols using the client-server and publisher-subscriber communication models. The client-server and publisher-subscriber communications between the two nodes were implemented using Transmission Control Protocol/Internet Protocol (IP) and User Datagram Protocol/IP, respectively.

Summary

This article introduces the IEEE 1451 standard for networked smart transducers. It discusses the concepts of smart transducers, IEEE 1451 smart transducers, the architecture of the IEEE 1451 family of standards, application of IEEE 1451, and example implementations of the IEEE 1451 standards. In conclusion, the IEEE 1451 suite of standards provides a set of standard interfaces for networked smart transducers, helping to achieve sensor plug and play and interoperability for industry and government.

References

- W. Elmenreich and S. Pizek, "Smart transducers—Principles, communications, and configuration," [Online], 10 July 2007, Available <http://www.vmars.tuwien.ac.at/~wilfried/papers/2003/rr-10-2003.pdf>.
- Smart Transducer Interface Specification, (2007, June 30). [Online] Available <http://www.omg.org/docs/formal/03-01-01.pdf>.

Available <http://www.omg.org/docs/formal/03-01-01.pdf>.

[3] *Standard for a Smart Transducer Interface for Sensors and Actuators—Common Functions, Communication Protocols, and Transducer Electronic Data Sheet (TEDS) Formats*, IEEE STD 1451.0-2007, IEEE Instrumentation and Measurement Society, TC-9, The Institute of Electrical and Electronics Engineers, Inc., New York, NY, October 5, 2007.

[4] K. Lee, "IEEE 1451: A standard in support of smart transducer networking," in *Proc. 17th IEEE Instrumentation and Measurement Technology Conference 2000*, 2000, Vol. 2, pp. 525–528.

[5] E. Song and K. Lee, "Smart transducer web services based on IEEE 1451.0 Standard," *Proc. IEEE Instrumentation and Measurement Technology Conference 2007*, 2007.

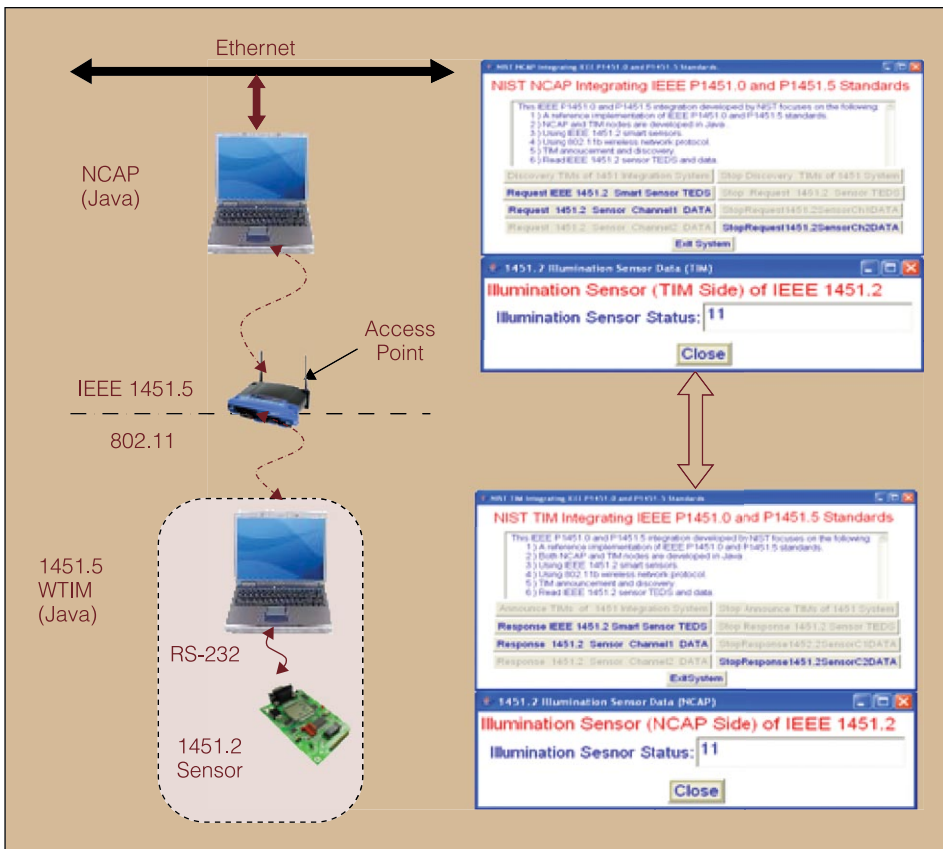

Fig. 7. An IEEE 1451.0 and 1451.5 implementation.

- [6] *Standard for a Smart Transducer Interface for Sensors and Actuators—Network Capable Application Processor (NCAP) Information Model*, IEEE STD 1451.1-1999, IEEE Instrumentation and Measurement Society, TC-9, The Institute of Electrical and Electronics Engineers, Inc., New York, NY, June 26, 1999.
- [7] K. Lee and R. Schneeman, "Distributed measurement and control based on the IEEE 1451 smart transducer interface standards," *IEEE Trans. Instrum. Meas.*, vol. 49, (no. 3), pp. 621–627, Jun 2000.
- [8] K. Lee and E.Y. Song, "Object-oriented application framework for IEEE 1451.1 standard," *IEEE Trans. Instrum. Meas.*, vol. 54, (no. 4), pp. 1527–1533, Aug 2005.
- [9] *Standard for a Smart Transducer Interface for Sensors and Actuators—Transducer to Microprocessor Communication Protocols and Transducer Electronic Data Sheet (TEDS) Formats*, IEEE STD 1451.2-1997, IEEE Instrumentation, SH99685, and Measurement Society, TC-9, The Institute of Electrical and Electronics Engineers, Inc., New York, NY, September 25, 1998.
- [10] *Standard for a Smart Transducer Interface for Sensors and Actuators—Digital Communication and Transducer Electronic Data Sheet (TEDS) Formats for Distributed Multidrop Systems*, IEEE STD 1451.3-2003, IEEE Instrumentation and Measurement Society, TC-9, The Institute of Electrical and Electronics Engineers, Inc., New York, NY, March 31, 2004.
- [11] *Standard for a Smart Transducer Interface for Sensors and Actuators—Mixed-Mode Communication Protocols and Transducer Electronic Data Sheet (TEDS) Formats*, IEEE STD 1451.4-1994, IEEE Instrumentation and Measurement Society, TC-9, The Institute of Electrical and Electronics Engineers, Inc., New York, NY, December 15, 2004.
- [12] *Standard for a Smart Transducer Interface for Sensors and Actuators—Wireless Communication and Transducer Electronic Data Sheet (TEDS) Formats*, IEEE STD 1451.4-2007, IEEE Instrumentation and Measurement Society, TC-9, The Institute of Electrical and Electronics Engineers, Inc., New York, NY, October 5, 2007.
- [13] IEEE P1451.6—Proposed Standard for a High-Speed CANopen-Based Transducer Network Interface for Intrinsically Safe and Non-Intrinsically Safe Applications, (2007, May 25). [Online] Available <http://grouper.ieee.org/groups/1451/6/>.
- [14] IEEE P1451.7—Proposed Standard for a Smart Transducer Interface for Sensors and Actuators—Transducers to Radio Frequency Identification (RFID) Systems Communication Protocols and Transducer Electronic Data Sheet Formats, (2007,

August 30). [Online] Available <http://standards.ieee.org/board/nas/projects/1451-7.pdf>.

[15] How Can IEEE 1451 Be Applied, (2007, June 10). [Online] Available <http://ieee1451.nist.gov/>.

[16] E. Song and K. Lee, "An implementation of the proposed IEEE 1451.0 and 1451.5 standards," *IEEE Sensors and Applications Symposium*, Houston, TX, February 7–9, 2006.

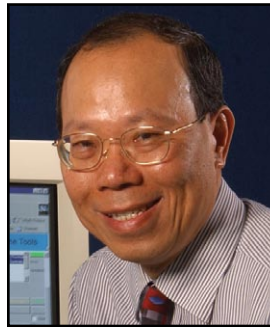

Kang Lee (kang.lee@nist.gov) is Leader of the Sensor Development and Application Group at the Manufacturing Engineering Laboratory of NIST. Kang's responsibilities include overseeing research activities on distributed measurement and control systems, smart and wireless sensor networks, sensor networks for manufacturing and homeland security systems,

sensor integration with RFID, acoustical metrology, and the development of related national and international standards. He also serves as Chairman of the IEEE Instrumentation & Measurement Society's Technical Committee on Sensor Technology that is responsible for the development of the IEEE 1451 and 1588 standards.



Eugene Y. Song (ysong@nist.gov) received the Ph.D. degree in manufacturing engineering from Tsinghua University, Beijing, China, in 1998. He was formerly a full Professor at Hebei University of Technology, Tangshan, China. He is a Guest Researcher in the Manufacturing Metrology Division of the Manufacturing Engineering Laboratory at NIST, Gaithersburg, Maryland. His

current research interests include networked smart sensor interface, IEEE 1451 standards, service-oriented sensor interoperability, and distributed measurement and control systems.

For additional information and technical details, see our sister publication,
the IEEE TRANSACTIONS ON INSTRUMENTATION AND MEASUREMENT:

K. Lee, R. Schneeman, "Distributed measurement and control based on the IEEE 1451 smart transducer interface standards", *IEEE Transactions on Instrumentation and Measurement*, volume 49, no. 3, p621-627, Jun, 2000.

K. Lee, E. Y. Song, "Object-oriented application framework for IEEE 1451.1 standard", *IEEE Transactions on Instrumentation and Measurement*, volume 54, no. 4, p1527-1533, August, 2005.