

**PB90-910406  
NTSB/AAR-90/06**

**NATIONAL  
TRANSPORTATION  
SAFETY  
BOARD**

**AIRCRAFT ACCIDENT REPORT**

**UNITED AIRLINES FLIGHT 232  
McDONNELL DOUGLAS DC-10-10  
SIOUX GATEWAY AIRPORT  
SIOUX CITY, IOWA  
JULY 19, 1989**

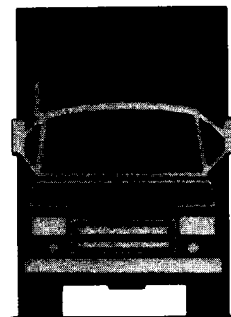
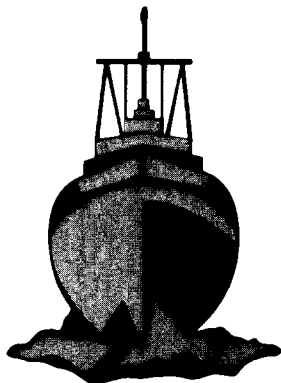
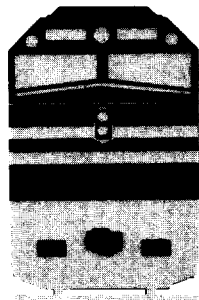

The National Transportation Safety Board is an independent Federal agency dedicated to promoting aviation, railroad, highway, marine, pipeline, and hazardous materials safety. Established in 1967, the agency is mandated by the Independent Safety Board Act of 1974 to investigate transportation accidents, determine the probable cause of accidents, issue safety recommendations, study transportation safety issues, and evaluate the safety effectiveness of government agencies involved in transportation.

The Safety Board makes public its actions and decisions through accident reports, safety studies, special investigation reports, safety recommendations, and statistical reviews. Copies of these documents may be purchased from the National Technical Information Service, 5285 Port Royal Road, Springfield, Virginia 22161. Details on available publications may be obtained by contacting:

**National Transportation Safety Board  
Public Inquiries Section, RE-51  
800 Independence Avenue, S.W.  
Washington, D.C. 20594  
(202)382-6735**

**TECHNICAL REPORT DOCUMENTATION PAGE**

<b>1. Report No.</b> NTSB/AAR-90/06		<b>2. Government Accession No.</b> PB90-910406		<b>3. Recipient's Catalog No.</b>	
<b>4. Title and Subtitle</b> Aircraft Accident Report-- United Airlines Flight 232, McDonnell Douglas DC-10-10, Sioux Gateway Airport, Sioux City, Iowa, July 19, 1989				<b>5. Report Date</b> November 1, 1990	
				<b>6. Performing Organization Code</b>	
<b>7. Author(s)</b>				<b>8. Performing Organization Report No.</b>	
<b>9. Performing Organization Name and Address</b>  National Transportation Safety Board Office of Aviation Safety Washington, D.C. 20594				<b>10. Work Unit No.</b> 5158D	
				<b>11. Contract or Grant No.</b>	
				<b>13. Type of Report and Period Covered</b> Aircraft Accident Report July 19, 1989	
<b>12. Sponsoring Agency Name and Address</b>  NATIONAL TRANSPORTATION SAFETY BOARD Washington, D.C. 20594				<b>14. Sponsoring Agency Code</b>	
<b>15. Supplementary Notes</b>					
<b>16. Abstract</b> This report explains the crash of a United Airlines McDonnell Douglas DC-10-10 in Sioux City, Iowa, on July 19, 1989. The safety issues discussed in the report are engine fan rotor assembly design, certification, manufacturing, and inspection; maintenance and inspection of engine fan rotor assemblies; hydraulic flight control system design, certification, and protection from uncontained engine debris; cabin safety, including infant restraint systems; and aircraft rescue and firefighting facilities. Safety recommendations addressing these issues were made to the Federal Aviation Administration and the U.S. Air Force.					
<b>17. Key Words</b>				<b>18. Distribution Statement</b> This document is available to the public through the National Technical Information Service, Springfield, Virginia 22161	
<b>19. Security Classification (of this report)</b> UNCLASSIFIED		<b>20. Security Classification (of this page)</b> UNCLASSIFIED		<b>21. No. of Pages</b> 126	<b>22. Price</b>

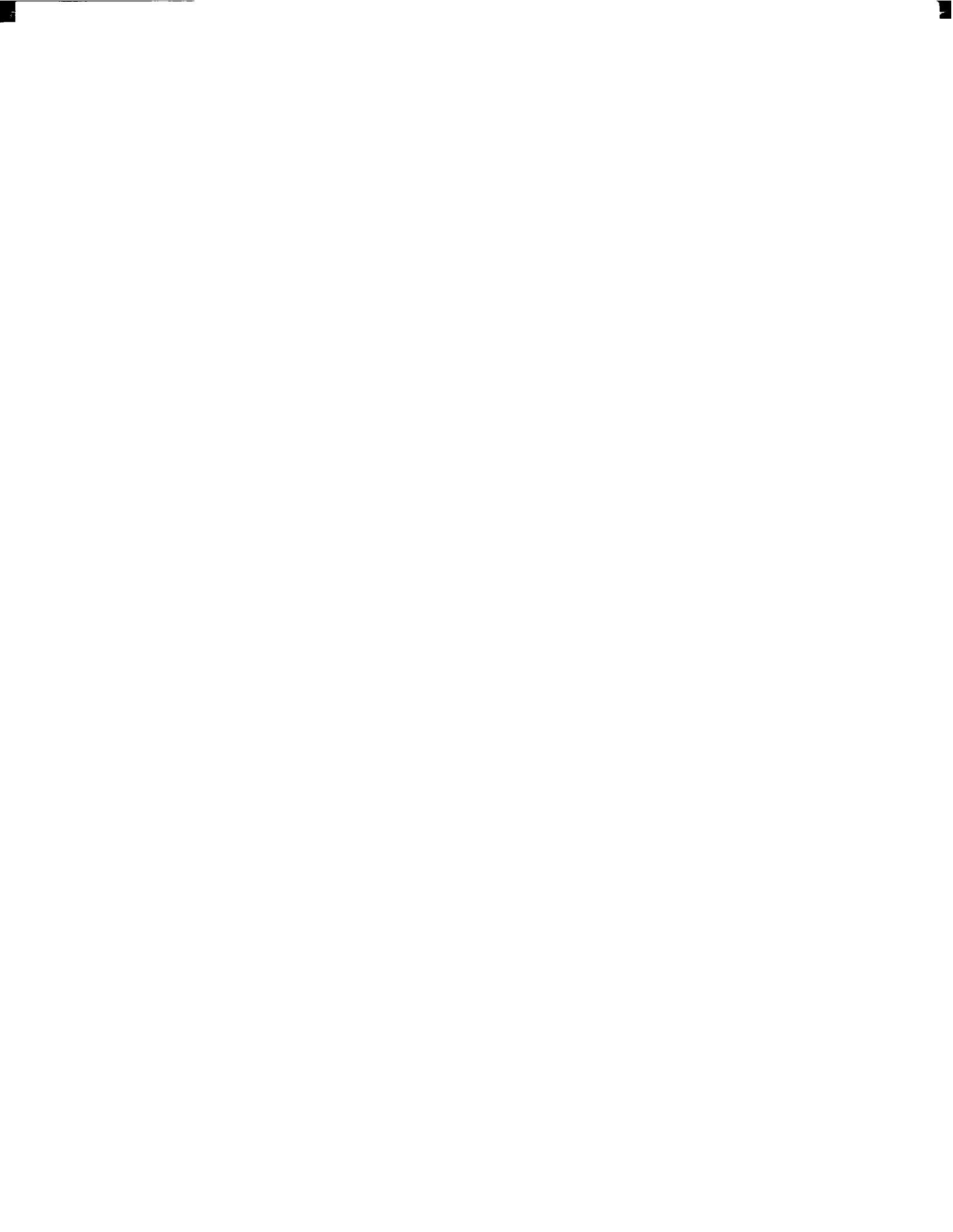

## CONTENTS

EXECUTIVE SUMMARY . . . . .		v
1.	<b>FACTUAL INFORMATION</b>	
1. 1	History of Flight . . . . .	1
1. 2	Injuries to Persons . . . . .	5
1. 3	Damage to Airplane . . . . .	6
1. 4	Other Damage . . . . .	6
1. 5	Personnel Information . . . . .	6
1. 6	Airplane Information . . . . .	11
1. 6. 1	No. 2 Engine Historical Data . . . . .	12
1. 6. 2	Stage 1 Fan Disk Historical Data . . . . .	15
1. 6. 3	Airplane Flight Controls and Hydraulics--Description . . . . .	15
1. 7	Meteorological Information . . . . .	19
<b>1.8</b>	Aids to Navigation . . . . .	19
<b>1.9</b>	Communications . . . . .	19
<b>1.9.1</b>	United Airlines Company Flight Following . . . . .	19
1. 10	Airport Information . . . . .	20
1. 11	Flight Recorders . . . . .	21
1. 11. 1	Cockpit Voice Recorder . . . . .	21
1. 11. 2	Flight Data Recorder . . . . .	23
1. 12	Wreckage and Impact Information . . . . .	24
1. 12. 1	Impact Marks and Ground Damage . . . . .	25
1. 12. 2	Reconstruction of Empennage . . . . .	30
1. 12. 3	Damage to Inlet Duct and Vertical Stabilizer Spars (Banjo Frames) . . . . .	32
1. 12. 4	Hydraulic System Damage . . . . .	32
1. 13	Medical and Pathological Information . . . . .	35
1. 14	Fire . . . . .	35
1. 14. 1	Airport Response . . . . .	35
1. 14. 2	Off-Airport Response . . . . .	38
1. 14. 3	The Kovatch P-18 Water Supply Vehicle . . . . .	38
1. 15	Survival Aspects . . . . .	39
1. 15. 1	Cabin Preparation . . . . .	39
<b>1.15.2</b>	Infants . . . . .	40
1. 16	Tests and Research . . . . .	41
1. 16. 1	Design of CF6-6 Engine Stage 1 Fan Disk . . . . .	41
1. 16. 2	Examination of No. 2 Engine Stage 1 Fan Disk . . . . .	41
1. 16. 3	Examination of Containment Ring . . . . .	47
1. 16. 4	Other No. 2 Engine Hardware . . . . .	47
1. 16. 5	Sister Fan Disks . . . . .	48
1. 16. 6	No. 2 Engine Fan Disk Fracture Surface Chemical Residue Examination . . . . .	49
1. 17	Additional Information . . . . .	49
1. 17. 1	Fan Disk Manufacturing Processes and Hard Alpha . . . . .	49
1. 17. 2	ALCOA Forging and Records . . . . .	51
1. 17. 3	<b>GEAE Fan Disk S/N MPO 00385 Machining and Finishing Records</b> . . . . .	53
1. 17. 4	Inspections During Disk Manufacture . . . . .	57
1. 17. 5	Responsibility for Continuing Airworthiness . . . . .	59
1. 17. 6	Certification Requirements . . . . .	62

1. 17. 6. 1	Certification Requirements - Aircraft .....	62
1. 17. 6. 2	Certification Requirements - Engine .....	63
1. 17. 7	Field Inspection Programs .....	64
1. 17. 8	Hydraulic System Enhancement .....	66
1. 17. 9	Historical Review .....	67
1. 17. 10	Airplane Flight Characteristics with Immovable Control Surfaces .....	70
1. 17. 10. 1	General Characteristics .....	70
1. 17. 10. 2	Flight Simulator Studies .....	72
1. 18	Useful Investigative Techniques .....	73
1. 18. 1	Special Investigative Techniques - Photograph Image Analysis .....	73
<b>2.</b>	<b>ANALYSIS</b>	
<b>2.1</b>	General .....	<b>73</b>
<b>2.2</b>	Accident Sequence .....	<b>74</b>
<b>2.3</b>	Performance of UAL 232 Flightcrew .....	<b>75</b>
<b>2.4</b>	Analysis of Fan Disk Fracture .....	<b>77</b>
<b>2.4.1</b>	Separation of Fan Disk .....	<b>77</b>
<b>2.4.2</b>	Initiation and Propagation of Fatigue Crack.....	<b>77</b>
<b>2.4.3</b>	Source of Hard Alpha Defect .....	<b>78</b>
<b>2.4.4</b>	Formation of Cavity .....	<b>79</b>
<b>2.5</b>	Origin of Accident Fan Disk MPO 00385 .....	<b>80</b>
<b>2.5.1</b>	Quality Assurance During Manufacturing Process .....	<b>83</b>
<b>2.6</b>	Operator Inspection Program and Methods .....	<b>85</b>
<b>2.7</b>	Philosophy of Engine/Airframe Design .....	<b>89</b>
<b>2.7.1</b>	Hydraulic Systems/Flight Control Design Concept and Certification .....	<b>89</b>
<b>2.7.2</b>	Future Certification Concepts .....	<b>90</b>
<b>2.8</b>	Survival Aspects .....	<b>92</b>
<b>2.9</b>	Emergency Management .....	<b>93</b>
<b>2.10</b>	Adequacy of Actions Taken Since the Accident .....	<b>95</b>
<b>2.10.1</b>	<b>CF6-6 Fan Disk Inspection Programs .....</b>	<b>95</b>
<b>2.10.2</b>	<b>Hydraulic System Enhancement .....</b>	<b>97</b>
<b>2.10.3</b>	<b>Industry Task Group Efforts .....</b>	<b>98</b>
<b>2.10.4</b>	<b>Damage Tolerance for Commercial Transport Engines .....</b>	<b>99</b>
<b>3.</b>	<b>CONCLUSIONS</b>	
<b>3.1</b>	Findings .....	<b>100</b>
<b>3.2</b>	Probable Cause .....	<b>102</b>
<b>4.</b>	<b>RECOMMENDATIONS .....</b>	<b>102</b>
<b>5.</b>	<b>APPENDICES</b>	
	Appendix A--Investigation and Hearing .....	111
	Appendix B--Personnel Information .....	112
	Appendix C--Horizontal Stabilizer Damage Diagram .....	115
	Appendix D--Douglas Aircraft Company Letter: Controllability with all Hydraulic Failure .....	116

## EXECUTIVE SUMMARY

On July 19, 1989, at 1516, a DC-10-10, N1819U, operated by United Airlines as flight 232, experienced a catastrophic failure of the No. 2 tail-mounted engine during cruise flight. The separation, fragmentation and forceful discharge of stage 1 fan rotor assembly parts from the No. 2 engine led to the loss of the three hydraulic systems that powered the airplane's flight controls. The flight crew experienced severe difficulties controlling the airplane, which subsequently crashed during an attempted landing at Sioux Gateway Airport, Iowa. There were 285 passengers and 11 crewmembers onboard. One flight attendant and 110 passengers were fatally injured.

The National Transportation Safety Board determines that the probable cause of this accident was the inadequate consideration given to human factors limitations in the inspection and quality control procedures used by United Airlines' engine overhaul facility which resulted in the failure to detect a fatigue crack originating from a previously undetected metallurgical defect located in a critical area of the stage 1 fan disk that was manufactured by General Electric Aircraft Engines. The subsequent catastrophic disintegration of the disk resulted in the liberation of debris in a pattern of distribution and with energy levels that exceeded the level of protection provided by design features of the hydraulic systems that operate the DC-10's flight controls.

The safety issues raised in this report include:

1. General Electric Aircraft Engines' (GEAE) CF6-6 fan rotor assembly design, certification, manufacturing, and inspection.
2. United Airlines' maintenance and inspection of CF6-6 engine fan rotor assemblies.
3. DC-10 hydraulic flight control system design, certification and protection from uncontained engine debris.
4. Cabin safety, including infant restraint systems, and airport rescue and firefighting facilities.

Recommendations concerning these issues were addressed to the Federal Aviation Administration, the Secretary of the Air Force, the Air Transport Association and the Aerospace Industries Association.





NATIONAL TRANSPORTATION SAFETY BOARD  
WASHINGTON, D. C. 20594

AIRCRAFT ACCIDENT REPORT

UNITED AIRLINES FLIGHT 232, McDONNELL DOUGLAS DC-10-10  
SIOUX GATEWAY AIRPORT  
SIOUX CITY, IOWA  
JULY 19, 1989

1. FACTUAL INFORMATION

1.1 *History of Flight*

United Airlines (UAL) flight 232 (UA 232), a McDonnell Douglas DC-10-10, registration No. N1819U, was a scheduled passenger flight from Stapleton International Airport, Denver, Colorado, to Philadelphia, Pennsylvania, with an en route stop at Chicago, Illinois. The flight was conducted under Title 14 Code of Federal Regulations (CFR) Part 121. Flight 232 departed Denver at 1409 central daylight time. There were 285 passengers and 11 crewmembers on board.

The takeoff and the en route climb to the planned cruising altitude of 37,000 feet were uneventful. The first officer (copilot) was the flying pilot. The autopilot was engaged, and the autothrottles were selected in the speed mode for 270 KIAS. The flight plan called for a cruise speed of Mach 0.83.

About 1 hour and 7 minutes after takeoff, at 1516:10, the flightcrew heard a loud bang or an explosion, followed by vibration and a shuddering of the airframe. After checking the engine instruments, the flightcrew determined that the No. 2 aft (tail-mounted) engine had failed. (See figure 1). The captain called for the engine shutdown checklist. While performing the engine shutdown checklist, the second officer (flight engineer) observed that the airplane's normal systems hydraulic pressure and quantity gauges indicated zero.

The first officer advised that he could not control the airplane as it entered a right descending turn. The captain took control of the airplane and confirmed that it did not respond to flight control inputs. The captain reduced thrust on the No. 1 engine, and the airplane began to roll to a wings-level attitude.

The flightcrew deployed the air driven generator (ADG), which powers the No. 1 auxiliary hydraulic pump, and the hydraulic pump was selected "on." This action did not restore hydraulic power.

At 1520, the flightcrew radioed the Minneapolis Air Route Traffic Control Center (ARTCC) and requested emergency assistance and vectors to the nearest airport. Initially, Des Moines International Airport was suggested by ARTCC. At 1522, the air traffic controller informed the flightcrew

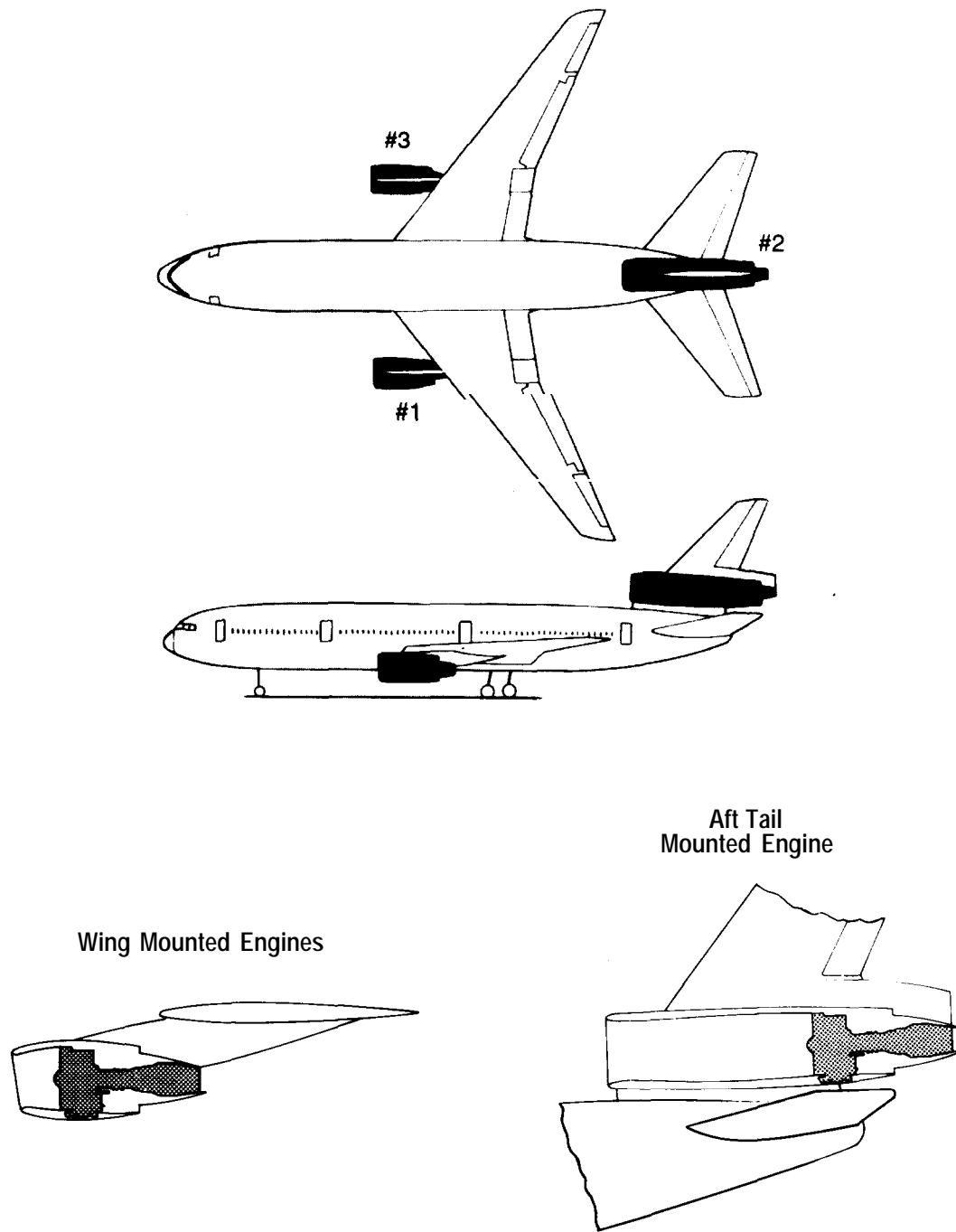

Figure 1. --DC-10 ai rpl ane vi ew i ll ustrated wi th engi ne arrangement.

that they were proceeding in the direction of Sioux City; the controller asked the flightcrew if they would prefer to go to Sioux City. The flightcrew responded, "affirmative." They were then given vectors to the Sioux Gateway Airport (SUX) at Sioux City, Iowa. (See figure 2). Details of relevant air traffic control (ATC) communications, cockpit conversations, airplane maneuvers, and airplane and engine system parameters are contained in Sections 1.9 and 1.11 of this report.

Crew interviews indicate that shortly after the engine failure, the passengers were informed of the failure of the No. 2 engine, and the senior flight attendant was called to the cockpit. She was told to prepare the cabin for an emergency landing. She returned to the cabin and separately informed the other flight attendants to prepare for an emergency landing. A flight attendant advised the captain that a UAL DC-10 training check airman, who was off duty and seated in a first class passenger seat, had volunteered his assistance. The captain immediately invited the airman to the cockpit, and he arrived about 1529.

At the request of the captain, the check airman entered the passenger cabin and performed a visual inspection of the airplane's wings. Upon his return, he reported that the inboard ailerons were slightly up, not damaged, and that the spoilers were locked down. There was no movement of the primary flight control surfaces. The captain then directed the check airman to take control of the throttles to free the captain and first officer to manipulate the flight controls.

The check airman attempted to use engine power to control pitch and roll. He said that the airplane had a continuous tendency to turn right, making it difficult to maintain a stable pitch attitude. He also advised that the No. 1 and No. 3 engine thrust levers could not be used symmetrically, so he used two hands to manipulate the two throttles.

About 1542, the second officer was sent to the passenger cabin to inspect the empennage visually. Upon his return, he reported that he observed damage to the right and left horizontal stabilizers.

Fuel was jettisoned to the level of the automatic system cutoff, leaving 33,500 pounds. About 11 minutes before landing, the landing gear was extended by means of the alternate gear extension procedure.

The flightcrew said that they made visual contact with the airport about 9 miles out. ATC had intended for flight 232 to attempt to land on runway 31, which was 8,999 feet long. However, ATC advised that the airplane was on approach to runway 22, which was closed, and that the length of this runway was 6,600 feet. Given the airplane's position and the difficulty in making left turns, the captain elected to continue the approach to runway 22 rather than to attempt maneuvering to runway 31. The check airman said that he believed the airplane was lined up and on a normal glidepath to the field. The flaps and slats remained retracted.

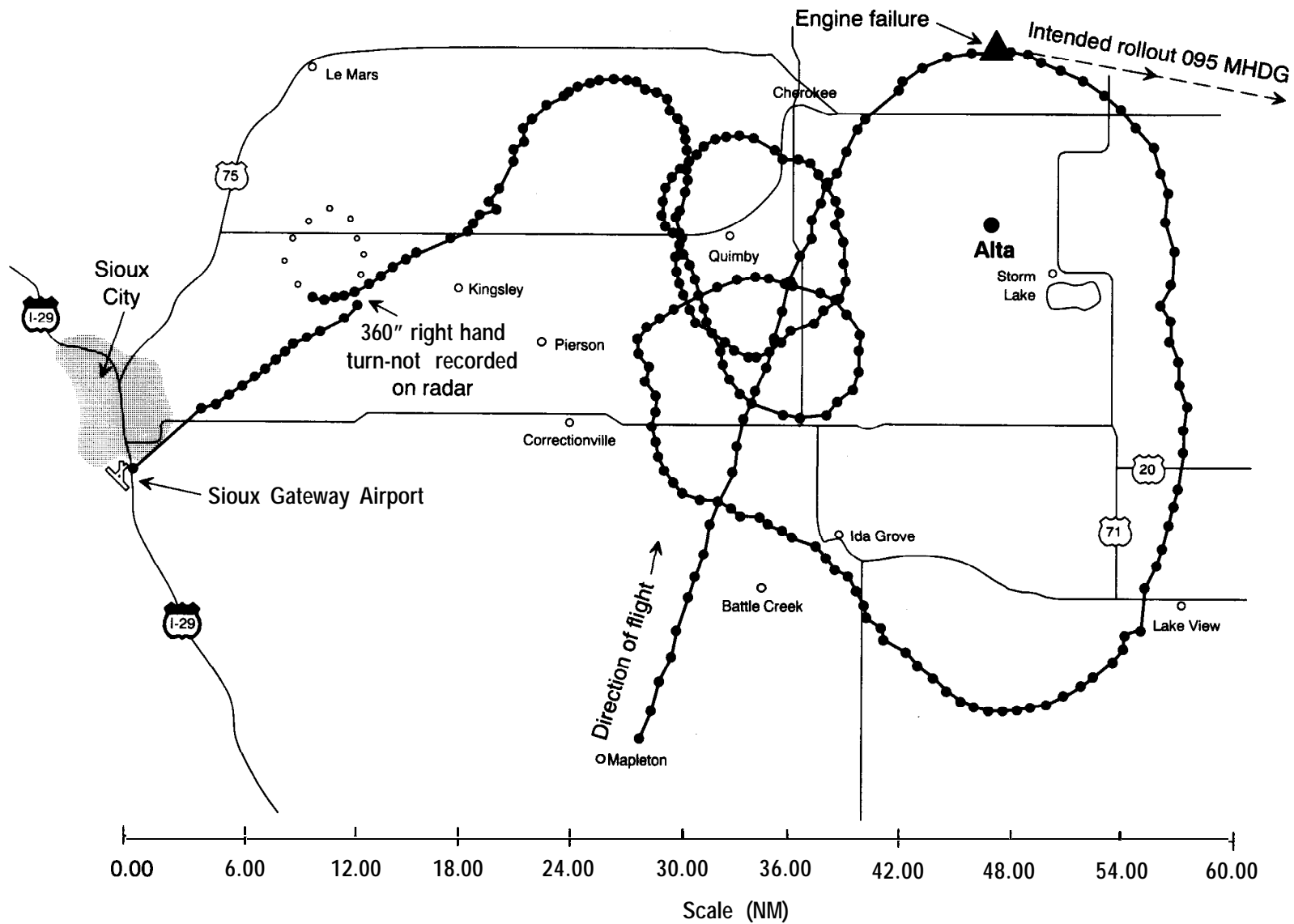

Figure 2. -- Ground track from radar plot.

During the final approach, the captain recalled getting a high sink rate alarm from the ground proximity warning system (GPWS). In the last 20 seconds before touchdown, the airspeed averaged 215 KIAS, and the sink rate was 1,620 feet per minute. Smooth oscillations in pitch and roll continued until just before touchdown when the right wing dropped rapidly. The captain stated that about 100 feet above the ground the nose of the airplane began to pitch downward. He also felt the right wing drop down about the same time. Both the captain and the first officer called for reduced power on short final approach.

The check airman said that based on experience with no flap/no slat approaches he knew that power would have to be used to control the airplane's descent. He used the first officer's airspeed indicator and visual cues to determine the flightpath and the need for power changes. He thought that the airplane was fairly well aligned with the runway during the latter stages of the approach and that they would reach the runway. Soon thereafter, he observed that the airplane was positioned to the left of the desired landing area and descending at a high rate. He also observed that the right wing began to drop. He continued to manipulate the No. 1 and No. 3 engine throttles until the airplane contacted the ground. He said that no steady application of power was used on the approach and that the power was constantly changing. He believed that he added power just before contacting the ground.

The airplane touched down on the threshold slightly to the left of the centerline on runway 22 at 1600. First ground contact was made by the right wing tip followed by the right main landing gear. The airplane skidded to the right of the runway and rolled to an inverted position. Witnesses observed the airplane ignite and cartwheel, coming to rest after crossing runway 17/35. Firefighting and rescue operations began immediately, but the airplane was destroyed by impact and fire.

The accident occurred during daylight conditions at 42° 25' north latitude and 96° 23' west longitude.

#### 1.2 Injuries to Persons

<u>Injuries</u>	<u>Crew</u>	<u>Passengers</u>	<u>Others</u>	<u>Total</u>
Fatal	1	110	0	111
Serious	6	41	0	47
Minor	0	13	0	125
None	11	285	0	13
Total			0	296

\*One passenger died 31 days after the accident as a result of injuries he had received in the accident. In accordance with 49 CFR 830.2, his injuries were classified "serious."

### 1.3 Damage to Airplane

The airplane was destroyed by impact and postcrash fire.

Photographs of the airplane were taken by observers on the ground during its final approach to Sioux Gateway Airport. They showed that the No. 2 engine fan cowling and the fuselage tail cone were missing. The remainder of the No. 2 engine appeared intact. Postcrash examination of the wreckage revealed that the No. 2 engine fan rotor components forward of the fan forward shaft, as well as part of the shaft, had separated from the engine in flight. (See figures 3 through 5).

The airplane's right wing began to break up immediately following touchdown. The remainder of the airplane broke up as it tumbled down the runway. The fuselage center section, with most of the left wing still attached, came to rest in a corn field after crossing runway 17/35.

The cockpit separated early in the sequence and came to rest at the edge of runway 17/35. The largely intact tail section continued down runway 22 and came to rest on taxiway "L." The engines separated during the breakup. The No. 1 and No. 3 engines came to rest near taxiway "L" and the intersection of runway 17/35, between 3,000 and 3,500 feet from the point of first impact. (See figure 6).

The No. 2 engine came to rest on taxiway "J" to the left of runway 22, about 1,850 feet from the point of first impact. The majority of the No. 2 engine fan module was not found at the airport.

The value of the airplane was estimated at **\$21,000,000.**

### 1.4 Other Damage

Airplane parts, which separated and fell to the ground on cultivated land, caused no significant damage. There was some minor damage to airport facilities and adjacent crops as a result of the crash landing.

### 1.5 Personnel Information

The flightcrew consisted of a captain, first officer, second officer and eight flight attendants. (See appendix 8).

The captain was employed by UAL on February 23, 1956. He had 29,967 hours of flight time logged with UAL, 7,190 hours of which was in the DC-10. He held an airline transport pilot certificate with type ratings in the DC-10 and B-727. He possessed a current first class airman medical certificate. His most recent proficiency check in the DC-10 was completed on April 26, 1989.

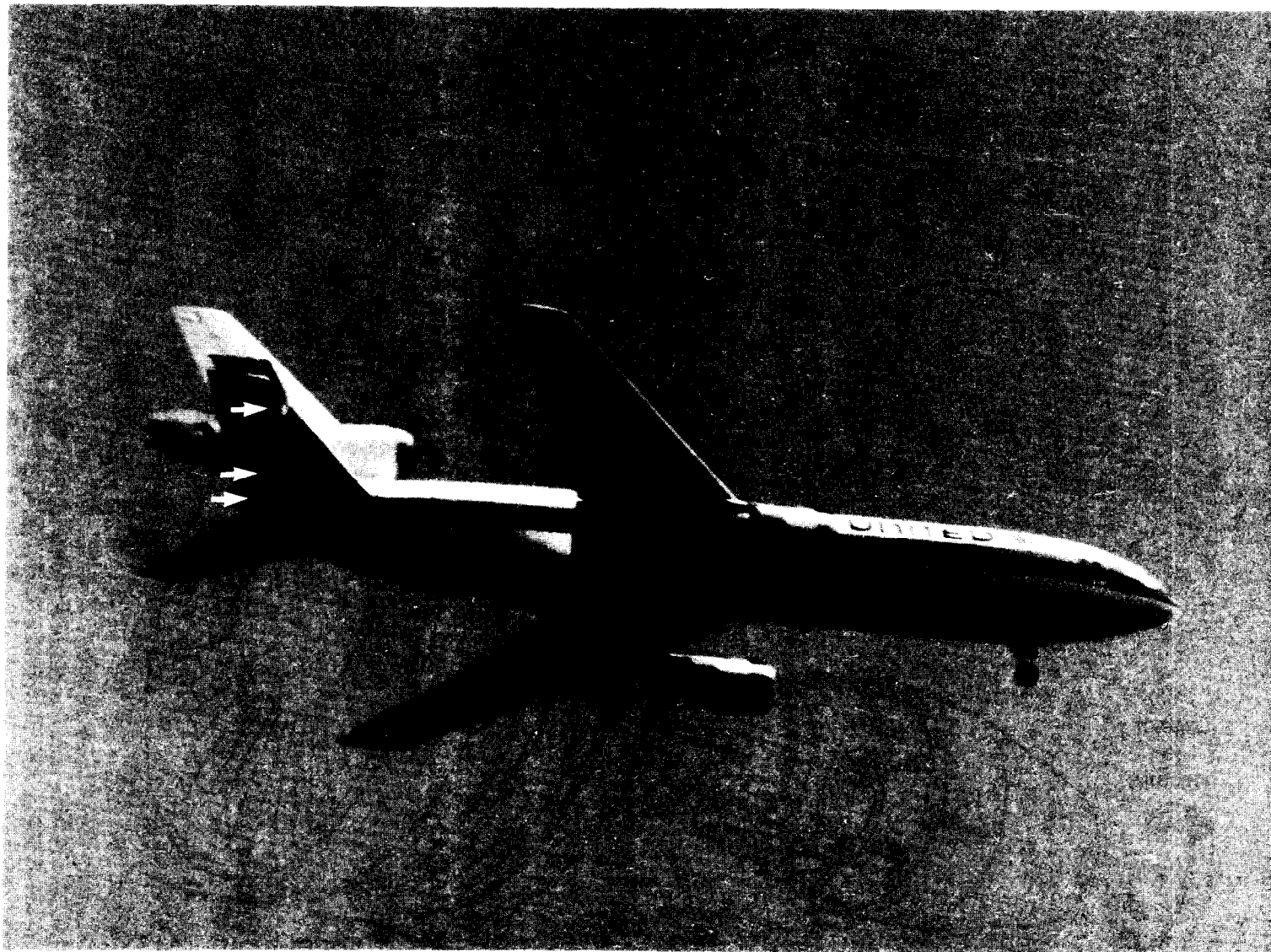

Figure 3. -- Photo (C. Zellmer) taken while flight 232 was approaching Sioux Gateway Airport. Arrows indicate damage to the right horizontal stabilizer. It is also evident that the No. 2 engine fan cowl door and the tail cone are missing.

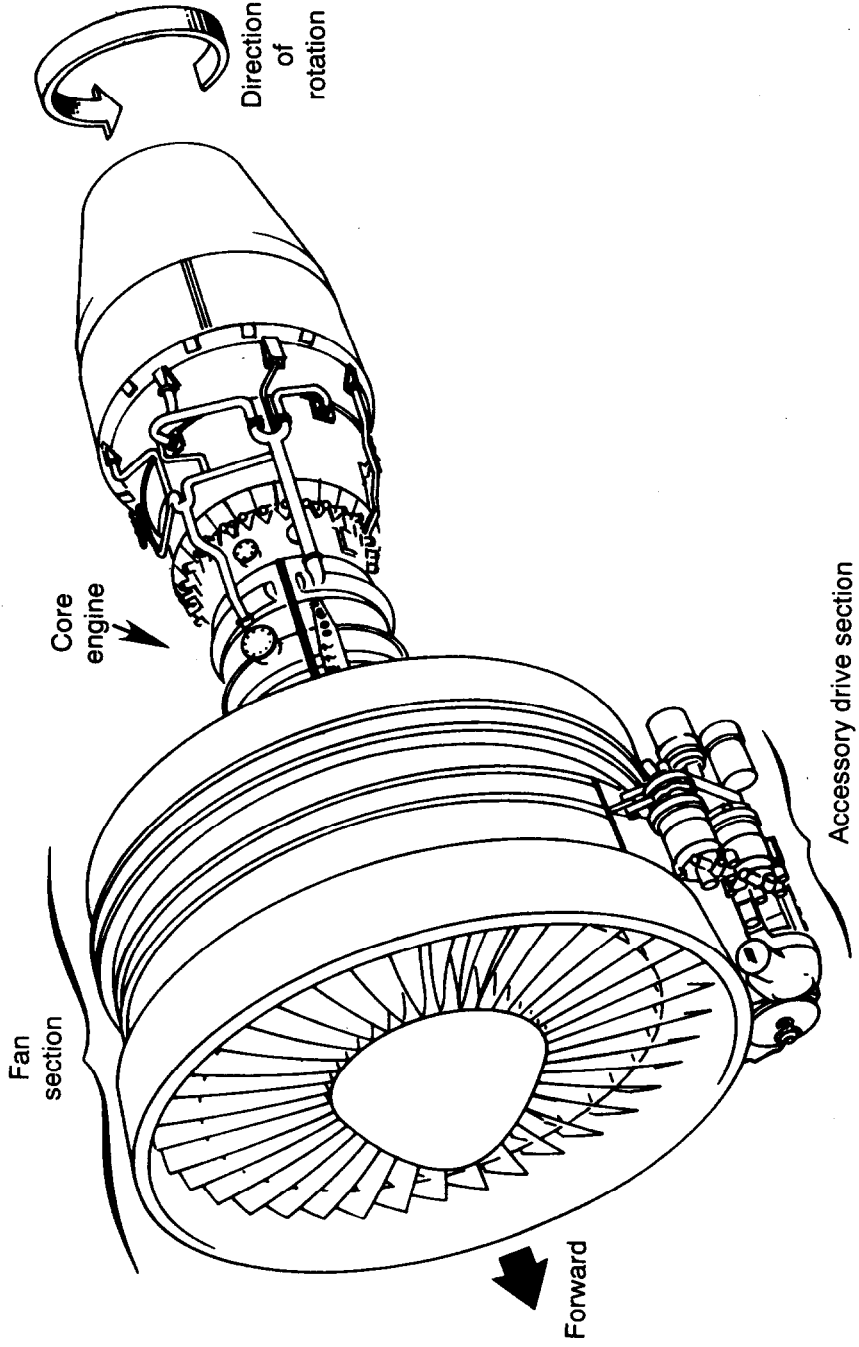

Figure 4.--CF6-6 engine.



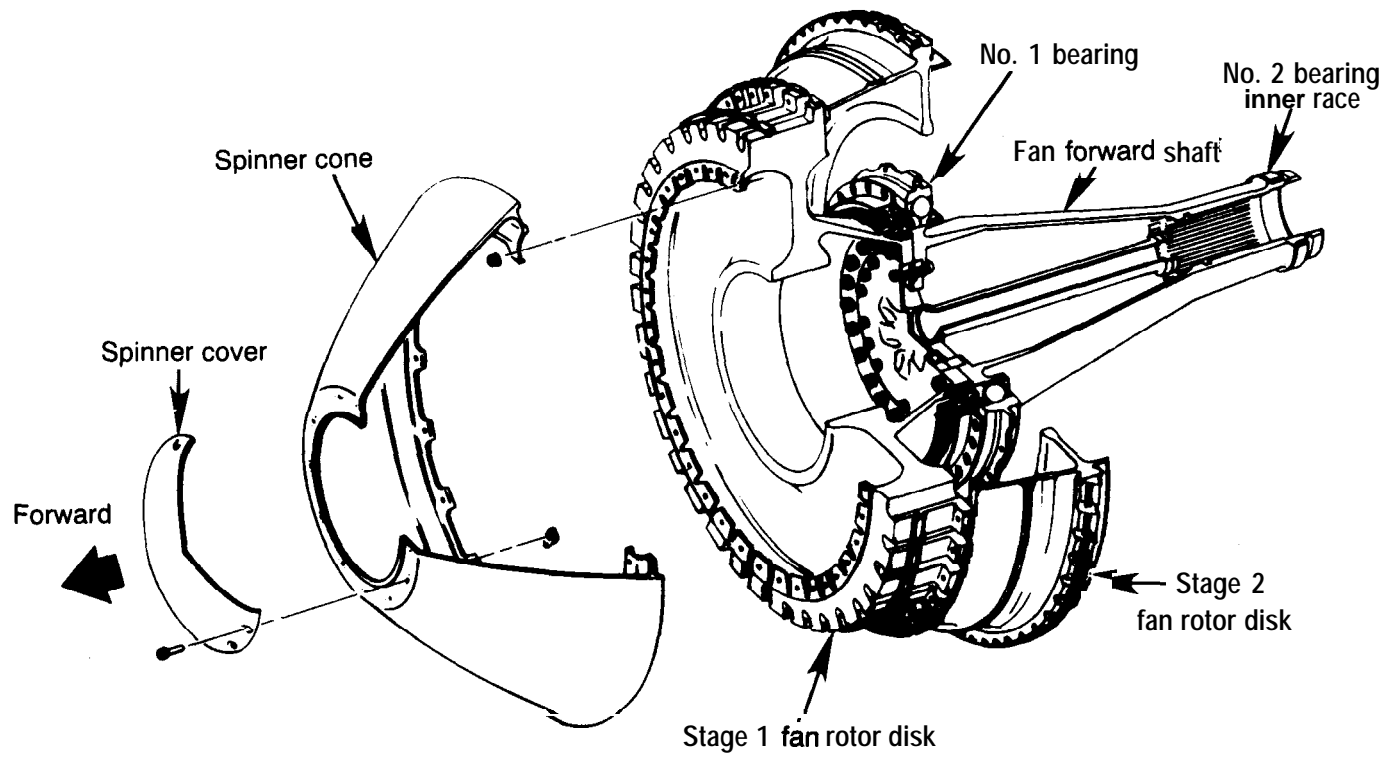

Figure 5. --CF6-6 fan rotor assembly.

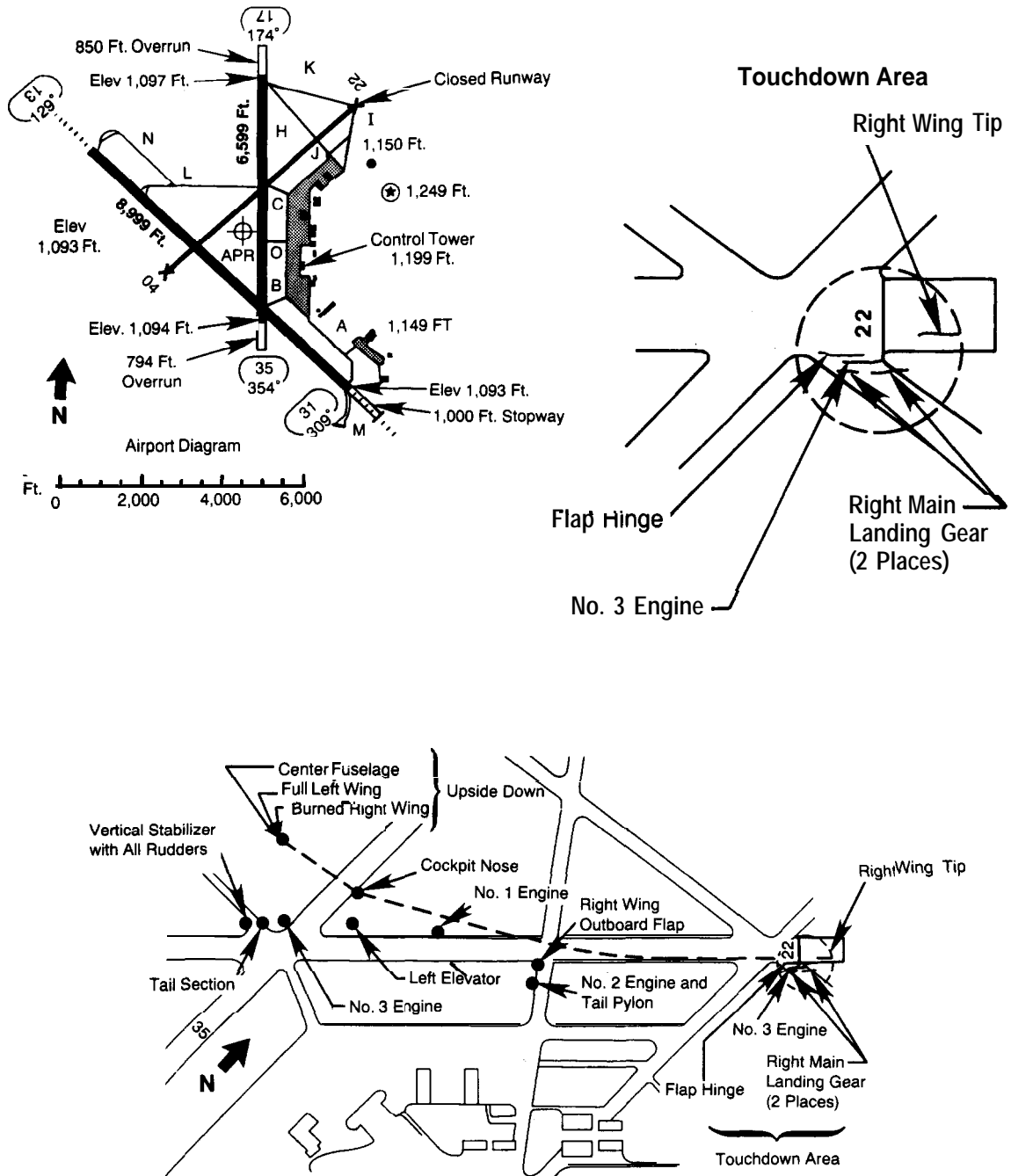

Figure 6. -- Sioux Gateway Airport and wreckage path of UA flight 232.

The first officer began airline employment on August 25, 1969. He estimated that he had logged 20,000 hours of flight time. He had accrued 665 hours as a first officer in the W-10. He held an airline transport pilot certificate with type ratings in the DC-10 and L-1011. He possessed a current first class airman medical certificate. His most recent proficiency check in the DC-10 was completed on August 8, 1988.

The second officer was employed by UAL on May 19, 1986. He estimated that he had 15,000 hours of flight time. UAL records indicated that he had accumulated 1,903 hours as a second officer in the B-727 and 33 hours in the DC-10. He held a flight engineer certificate for turbojet airplanes. He possessed a current second class airman medical certificate. His most recent proficiency check in the DC-10 was completed on June 8, 1989.

A review of flightcrew duty time indicated that the crew had complied with all relevant duty time limitations. The accident occurred on the third day of a 4-day scheduled trip sequence. The crew had a 22-hour layover in Denver prior to the departure of flight 232. The cockpit crew had flown together six times in the previous 90 days.

The off-duty check airman was employed by UAL on January 2, 1968. He held an airline transport pilot certificate with type rating in the DC-10 and a first class medical certificate. He had completed captain-transition training in the DC-10 on April 25, 1989, and was assigned as a DC-10 training check airman at UAL's Flight Training Center in Denver, Colorado. He had about 23,000 hours total flight time with 2,987 hours logged in the DC-10. He had 79 hours as captain in the DC-10.

#### 1.6 Airplane Information

UAL operated a total of 55 DC-10 airplanes; 47 airplanes were model DC-10-10, and 8 airplanes were model DC-10-30. The accident airplane, N1819U, fuselage No. 118, factory S/N 44618, was delivered in 1971 and was owned by UAL since that time. Prior to departure on the accident flight from Denver on July 19, 1989, the airplane had been operated a total of 43,401 hours and 16,997 cycles.

The maximum certificated takeoff weight for N1819U was 430,000 pounds. The center of gravity (CG) computed for departure was 21.9 percent mean aerodynamic chord (MAC). The calculated CG limits for this gross weight were 13.4 percent and 30.8 percent MAC, respectively. The takeoff gross weight was 369,268 pounds.

The accident airplane was powered by General Electric Aircraft Engines (GEAE) CF6-6D high bypass ratio turbofan engines. The CF6-6 engine was certified by the FAA on September 16, 1970.

Table 1 provides identification and historical information for the engines in N1819U at the time of the accident.

Table I

## Engines Historical Data

<u>Data</u>	<u>Number 1</u>	<u>Number 2</u>	<u>Number 3</u>
Engine Serial Number (ESN)	451-170	451-243	451-393
Total Time	44,078	42,436	39,338
Total Cycles	16,523	16,899	11,757
Time Since Last Maintenance	1,047	2,170	338
Cycles Since Last Maintenance	358	760	116
Time Since Last Shop Visit	3,635	2,170	338
Cycles Since Last Shop Visit	1,318	760	116
Date of Installation	5-9-88	10-25-88	6-11-89

Figure 7 contains a cutaway sectional drawing of the flow path and construction of the CF6-6 engine. The figure also shows the fan and accessory drive sections. Figure 8 displays the CF6-6 rotating assemblies. The portion of the No. 2 engine that departed the airplane is outlined by the dashed lines.

#### 1.6.1 No. 2 Engine Historical Data

Engine S/N 451-243 was first installed on June 23, 1972, in the No. 3 position of a UAL DC-10-10, registration airplane N1814U. Fan module S/N 51406, which contained stage 1 fan disk P/N 9137M52P36, S/N MPO 00385, was installed on engine S/N 451-243 during a shop visit in July 1988, at UAL. At that time, the engine had accumulated 40,266 hours and 16,139 cycles since new.

Engine S/N 451-243 was installed in the No. 1 position on UAL airplane registration N1807U on September 15, 1988. It was removed "for convenience" 8 days later after one flight and was installed in the No. 2 position on N1819U on October 25, 1988. The engine had accumulated 42,436 hours and 16,899 cycles at the time of the accident.

Examination of service records, crew writeups, action items, trend monitoring data, and flight recorder data indicated no abnormal engine operation prior to the in-flight incident, with the exception of certain autothrottle anomalies. The autothrottle system's inability to hold steady N was noted in the reported difficulties, and corrective action entries in UAL's Aircraft Maintenance Information System (AMIS) were dated on July 14, 17, and 19, 1989. On July 19, corrective action for the discrepancy was indicated accomplished at Philadelphia with the replacement of the autothrottle speed control and was signed off as "system ops check normal."

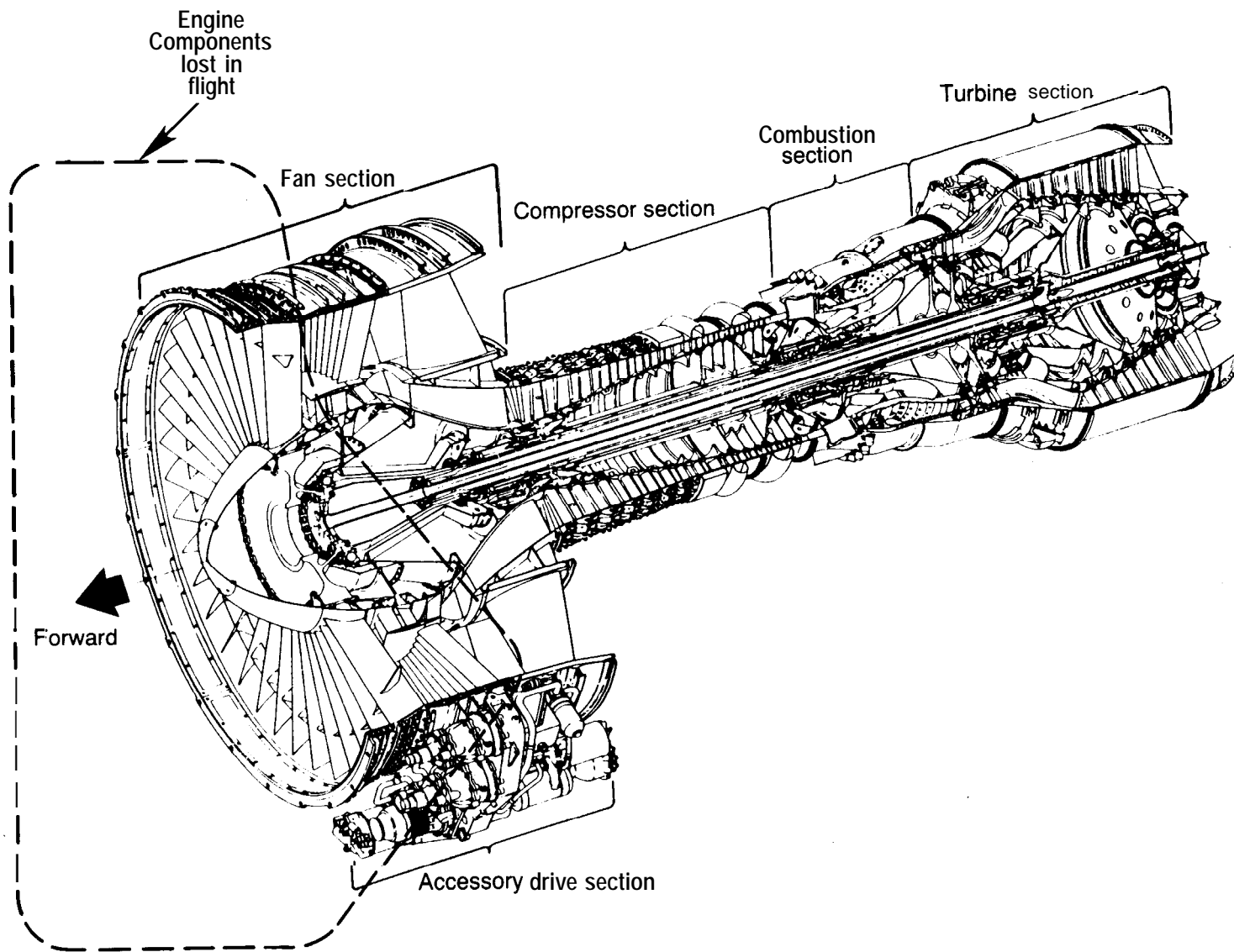

Figure 7. --CF6-6 engine cut away.

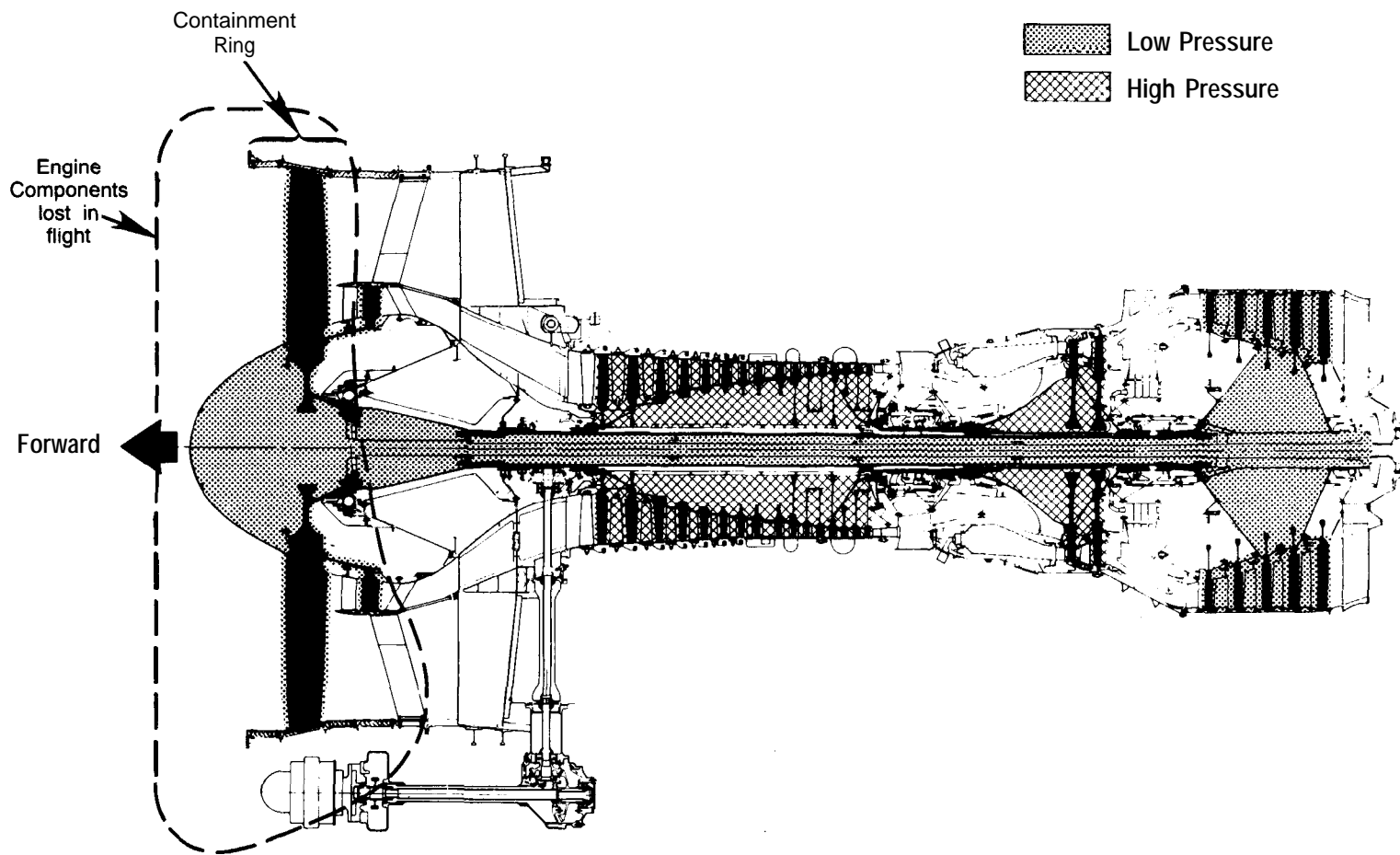

Figure 8. --CF6-6 rotating assemblies.

### 1.6.2 Stage 1 Fan Disk Historical Data

The stage 1 fan disk, part number (P/N) **9137M52P36**,<sup>1</sup> S/N MPO 00385, was processed in the manufacturing cycle at the GEAE-Evendale, Ohio, factory from September 3 to December 11, 1971. It was installed as a new part in engine S/N 451-251 in the GEAE production assembly facility in Evendale. The engine was shipped to Douglas Aircraft Company on January 22, 1972, where it was installed on a new DC-10-10.

During the next 17 years, the engines in which this stage 1 fan disk were installed were routinely overhauled and the fan module was disassembled. The disk was removed on the following dates for inspection: September 1972, November 1973, January 1976, June 1978, February 1982 and February 1988. This disk was accepted after each of six fluorescent penetrant inspections (FPI).<sup>2</sup> (See figure 9). Five of the six inspections were performed at the UAL CF6 Overhaul Shop in San Francisco, California. One of them was performed at the GEAE Airline Service Department in Ontario, California, in 1973. At the time of the accident, the stage 1 fan disk had accumulated 41,009 hours and 15,503 cycles since new. The last shop visit in February 1988, was 760 flight cycles before the accident, and FPI was performed at that time. The engine had been removed because of corrosion in the high pressure turbine (HPT) stage 1 nozzle guide vanes. At that time, the stage 1 fan disk had accumulated 38,839 hours and 14,743 cycles since new. Following this inspection, the disk was installed in engine S/N 451-243, the No. 2 engine on the accident airplane.

### 1.6.3 Airplane Flight Controls and Hydraulics--Description

Primary flight controls on the DC-10-10 consist of inboard and outboard ailerons, two-section elevators, and a two-section rudder. Secondary flight controls consist of leading edge slats, spoilers, inboard and outboard flaps, and a dual-rate movable horizontal stabilizer. Flight control surfaces are segmented to achieve redundancy. Each primary and

---

<sup>1</sup>Original P/N 9010M27P10 was superseded when the disk was modified during a GEAE shop visit in 1973. The fan blade dovetail slots were rebroached at that time.

<sup>2</sup>Fluorescent penetrant inspection (FPI) is the accepted industry inspection technique for interrogating nonferrous (nonmagnetic) component surfaces for discontinuities or cracks. The technique relies on the ability of a penetrant (a low-viscosity penetrating oil containing fluorescent dyes) to penetrate by capillary action into surface discontinuities of the component being inspected. The penetrant fluid is applied to the surface and allowed to penetrate into any surface discontinuities. Excess penetrant is then removed from the component surface. A developer is then applied to the component surface to act as a blotter and draw the penetrant back out of the surface discontinuity, producing an indication which fluoresces under ultraviolet lighting.

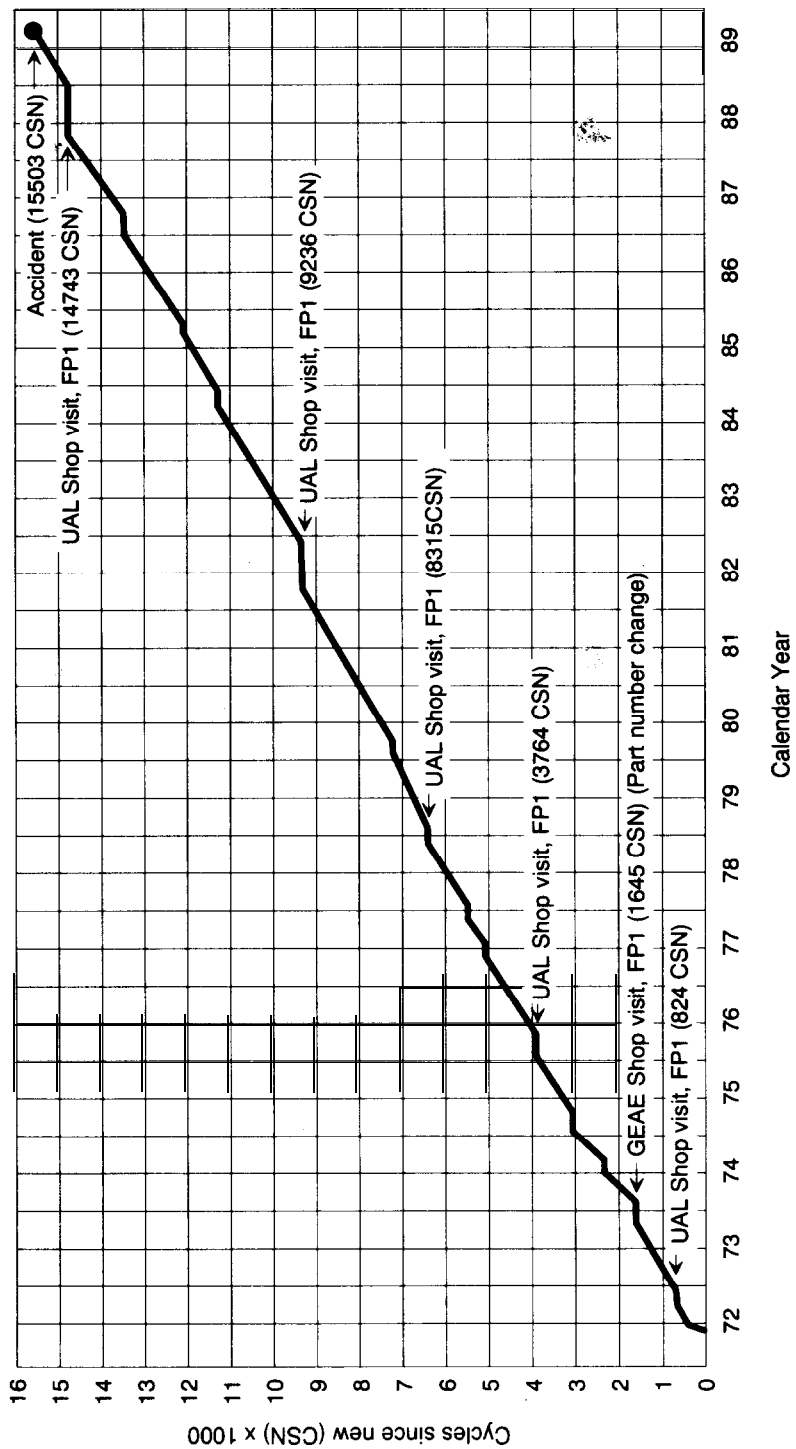

Figure 9.--- Inspection history of accident fan disk.  
(Data source GEAE)



secondary control surface is powered by two of three independent hydraulic systems.

The No. 1 hydraulic system provides power to the right inboard aileron and the left outboard aileron, the right inboard and outboard elevators, the left outboard elevator, the upper rudder, the horizontal stabilizer trim, and the captain's brake system. The No. 2 hydraulic system provides power to the right outboard aileron and the left inboard aileron, the inboard and outboard elevators on the left side, the outboard elevator on the right side, and the lower rudder. It also provides power to the isolated closed-loop system that operates the upper rudder. The No. 3 hydraulic system provides power to the right inboard and outboard aileron and the left inboard aileron, the inboard elevators on the right and left side, horizontal stabilizer trim, and the first officer's brake system. It also drives an isolated closed-loop system that powers the lower rudder actuator. These closed-loop arrangements allow for operation of the remaining parts of hydraulic systems No. 2 and No. 3 in the event of damage to the rudder hydraulic system. (See figure 10).

The three independent, continuously operating hydraulic systems are intended to provide power for full operation and control of the airplane in the event that one or two of the hydraulic systems are rendered inoperative. System integrity of at least one hydraulic system is required--fluid present and the ability to hold pressure--for continued flight and landing; there are no provisions for reverting to manual flight control inputs.

Each hydraulic system derives its power from a separate engine, with a primary and a reserve engine-driven pump providing hydraulic pressure. Either of these pumps can supply full power to its system. Backup power is provided by two reversible motor pumps, which transmit power from one system to another without fluid interconnection. This backup power system activates automatically without requiring flightcrew control, if fluid is still available in the unpowered system.

Electrical power can be used to drive either of two auxiliary pumps provided for the No. 3 hydraulic system. In an emergency situation where the engine-driven pumps are inoperative, an air-driven generator can be deployed into the airstream to supply electrical power to one of these auxiliary pumps.

The hydraulic components and piping are physically separated to minimize the vulnerability of the airplane to multiple hydraulic system failures in the event of structural damage. The No. 1 hydraulic system lines run along the left side of the fuselage to the rear of the airplane and along the front spar of the horizontal stabilizer and the vertical stabilizer. The No. 2 hydraulic system lines are routed from the center engine along the rear spar of the horizontal and vertical stabilizers. The No. 3 hydraulic system lines run along the right side of the fuselage to the tail area and along the rear spar of the horizontal stabilizer. The No. 2 hydraulic system lines are not routed forward of the rear wing spar, in order to isolate them from wing engine fragmentation, and No. 3 hydraulic system lines in the tail section

# DC-10 Hydraulic System Schematic

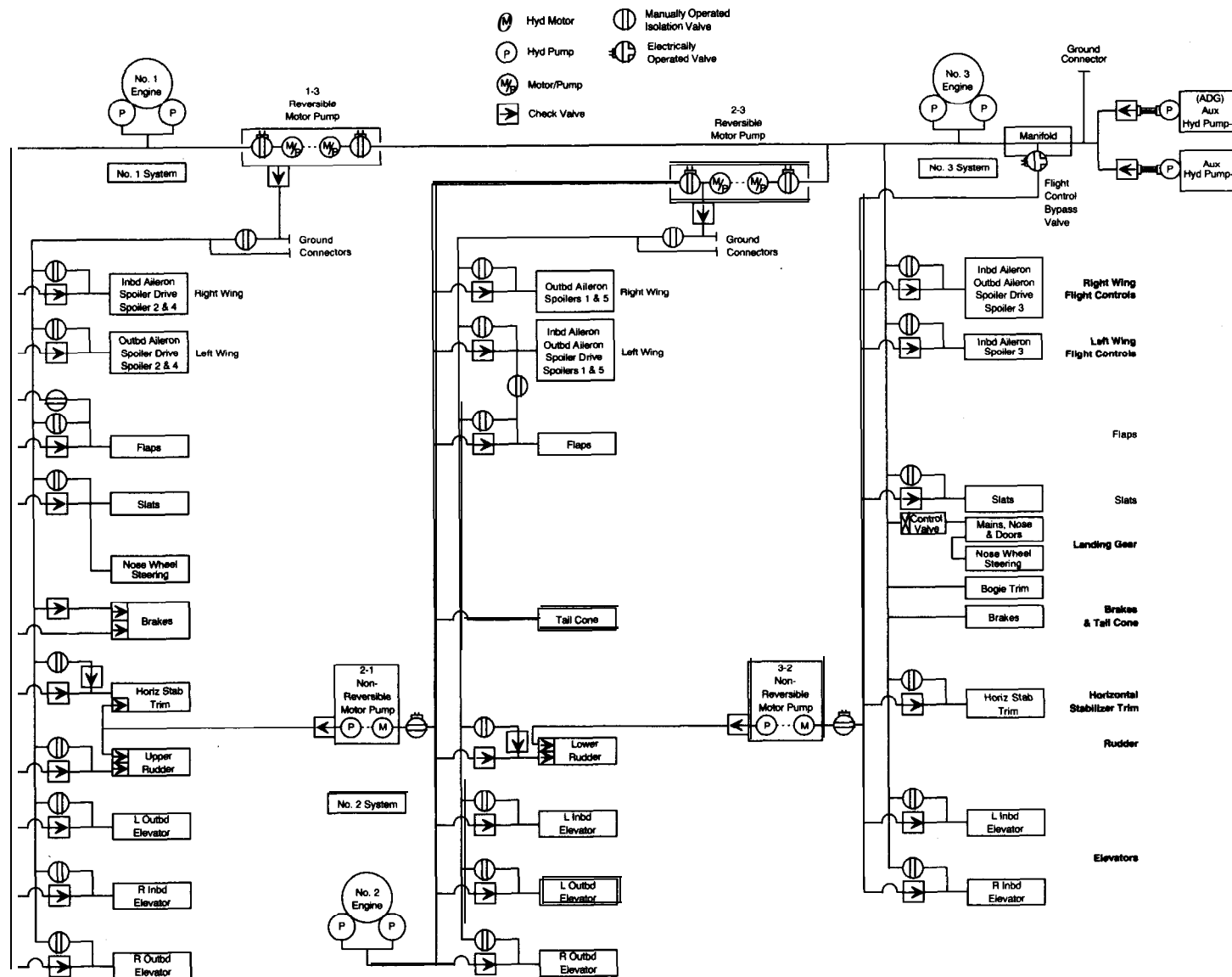

Figure 10.--DC-10 hydraulic system schematic.

are not routed aft of the inboard elevator actuators in order to minimize exposure to possible engine fragmentation damage from the tail-mounted engine.

The DC-10-10 hydraulic system was designed by the manufacturer and demonstrated to the FAA to comply with 14 CFR 25.901, which in part specified that, "no single [powerplant] failure or malfunction or probable combination of failures will jeopardize the safe operation of the airplane...."

#### 1.7 Meteorological Information

The surface weather observation taken at Sioux Gateway Airport at 1559 estimated a ceiling of 4,000 feet with broken clouds and 15 miles visibility. The temperature was 80° F, and winds were 360° at 14 knots. There were towering cumulus clouds in all quadrants. The last wind reported to the crew by the tower at 1558 was from 010° at 11 knots.

#### 1.8 Aids to Navigation

Instrument Landing System (ILS) approaches for runways 31 and 13 were available. When runway 22/04 was closed in 1988, published instrument approaches to that runway were cancelled. Electronic aids to navigation were not used by the crew of UA 232.

#### 1.9 Communications

##### 1.9.1 United Airlines Company Flight Following

At 1521, UA 232 sent an Aircraft Communications and Reporting System (ACARS) message to UAL's central dispatch facility<sup>3</sup> in Chicago, Illinois, requesting a call on frequency 129.45. Dispatch was initially unsuccessful in establishing voice contact. At 1523, dispatch initiated an ACARS call to UA 232 that resulted in positive contact.

The communication between UA 232, UAL's dispatch facility and UAL's San Francisco maintenance facility (SAM) was recorded by Aeronautical Radio Incorporated (ARINC). The recording revealed that, at 1525, UA 232 requested that dispatch put the flight in contact with "SAM immediately, it's a MAYDAY." UA 232's initial conversation with SAM occurred at 1527. The crew advised SAM of the loss of all hydraulic systems and quantities and requested whatever assistance SAM could provide. SAM was unable to provide instructions to the flightcrew that they did not already have.

At 1533, SAM informed UA 232 that it was making contact with UAL Flight Operations. At 1540, SAM advised the flightcrew that representatives of UAL's "Operational Engineering" department had been contacted to lend assistance. At 1545, SAM informed the flightcrew that, "Engineering is

---

<sup>3</sup>Dispatch facility - the air carrier section operating in accordance with Part 121, Subpart U - Dispatching and Flight Release Rules for flight planning, release, and monitoring of air carrier operations.

assembling right now and they're listening to us." UA 232 then advised SAM that the flight was at 9,000 feet and that they were planning to try to land at Sioux City. At 1549, the flightcrew informed SAM that they had just completed the alternate gear extension procedure. This communication was the last one ARINC recorded from UA 232.

The dispatcher working UA 232 stated that UAL Flight Operations asked her to inquire of the flightcrew about the possibility of landing in Lincoln, Nebraska, instead of Sioux City. Flight Operations was concerned about crosswinds and the need for a longer runway. The dispatcher forwarded this inquiry to the flightcrew at 1554 but did not receive a reply.

The dispatch office also received a call from UAL personnel in Sioux City stating that a DC-10 was east of the field experiencing difficulty. Dispatch contacted the Sioux Gateway Airport ATC tower directly and requested the dispatching of all emergency crash, fire, and rescue equipment.

#### 1.10 Airport Information

Sioux Gateway Airport serves Sioux City, Iowa, and is 6 nmi south of the city on a flat plain adjacent to the east bank of the Missouri River. Its elevation is 1,098 feet. The airport is owned and operated by the city as a public-use airport.

The airport is currently served by two runways. Runway 17/35, of asphalt construction, is 150 feet wide by 6,599 feet long. Both ends have overruns; 850 feet on the north end and 794 feet on the south end. Runway 13/31 is 150 feet wide by 8,999 feet long with 1,000 feet of overrun on the southeast end.

Runway 4/22 has a concrete surface, 150 feet wide by 6,888 feet long. It has paved shoulders 75 feet wide on each side, from the threshold area of runway 22 to the intersection with runway 13/31. Runway 22 has a turf overrun 550 feet long on its approach end, with a short asphalt base section just in front of the threshold. The terrain past the rollout end is cropland. Elevation at the threshold of runway 22 is 1,095 feet. The runway is marked with a yellow "X" painted over the numbers at each end to indicate that the runway is closed.

Sioux Gateway Airport is an "Index B" airport under 14 CFR 139. The airport "Index" is based on the size of scheduled air carrier aircraft that normally use that facility and the average daily departures of airplanes--in this case--DC-9, B-737, and B-727-100 series airplanes. A full-scale emergency exercise is required under 14 CFR 139 every 3 years, and a "table-top" review of the Airport Emergency Plan is required annually. A mass casualty exercise was conducted at the airport on October 10, 1987, that included the evacuation of about 90 casualties. The most recent drill was conducted on June 16, 1989. During the postaccident discussions, emergency personnel indicated that their preparedness training was a tremendous asset in this response.

DC-10 airplanes are not normally scheduled to land at Sioux Gateway Airport and require the use of an "Index D" airport, which recommends more than twice the quantity of firefighting extinguishing agents required of an "Index B" airport.

Aircraft rescue and firefighting (ARFF) services at the Sioux Gateway Airport are provided by the Iowa Air National Guard (ANG) through a joint-use agreement with the National Guard Bureau, the State of Iowa, and the City of Sioux City. Additionally, the local community reaction plan is coordinated with airport emergency services by the FAA control tower during its hours of operation through the Woodbury County Disaster and Emergency Services Communications Center in Sioux City.

## 1.11 Flight Recorders

### 1.11.1 Cockpit Voice Recorder

The airplane was equipped with a Sundstrand Model AV557B, serial no. 7510, cockpit voice recorder (CVR) that provided a good record of air traffic control and intracockpit communications for the last 33 minutes and 34 seconds of the flight. The recording began at 1526:42, during a transmission made by the captain to Sioux City Approach Control about 10 minutes after the No. 2 engine had failed.

At 1529:15, the CVR revealed a flight attendant relaying a message to the captain. The captain responded, "okay let'em come up" to the flightdeck. At 1529:35, the check airman arrived on the flightdeck. At 1529:41, the captain explained, "we don't have any controls." Fourteen seconds later, the captain directed the check airman to return to the cabin to determine if he could see any external damage to the airplane through the windows.

At 1530:32, the first officer asked, "What's the hydraulic quantity." The second officer reported that it was zero, followed by the first officer asking, "on all of them," and the second officer confirming the status. The captain followed by saying, "quantity is gone?" Three seconds later, he asked the second officer, "you got a hold of SAM?" The second officer reported, "he's not telling me anything." The captain responded, "we're not gonna make the runway fellas." At this point, it is believed that the check airman returned to the flightdeck, and the captain reported, "we have no hydraulic fluid, that's part of our main problem." The check airman stated, "okay both your inboard ailerons are sticking up that's as far as I can tell. I don't know." He then asked the captain for instructions, and the captain told him which throttle to manipulate. At 1532:02, the check airman reported that the flight attendants were slowly securing the cabin and the captain reported that "they better hurry we're gonna have to ditch I think."

At 1532:16, the captain reported to the approach controller that the flight had no hydraulic fluid and therefore no elevator control and that the flight might have to make a forced landing. Two seconds after the captain began his transmission, the check airman stated, "get this thing

down we're in trouble." At 1534:27, the captain decided to attempt a landing at Sioux City and asked the second officer for information to make a no-flap, no-slat landing. He also asked the controller for the ILS frequency heading to the runway and the length of the runway. The controller provided the frequency and reported runway 31 to be 9,000 feet long. At this point, the airplane was about 35 miles northeast of the airport.

At 1535:36, the captain instructed the second officer to start dumping fuel by using the quick dump. At 1537:55, the captain asked the check airman if he could manipulate the throttles to maintain a 10° to 15° turn, and the check airman replied that he "would try." At 1538:55, one of the pilots said that 200 knots would be the "clean maneuvering airspeed," and the first officer responded with, "two hundred and one eighty five on your bugs Al."

At 1540:39, the captain asked the senior flight attendant if everyone in the cabin was ready. The captain explained to the flight attendant that they had very little control of the airplane because of the loss of hydraulic flight controls and that they were going to attempt to land at Sioux City, Iowa. He stated that it would be a difficult landing and that he had doubts about the outcome and the crew's ability to carry out a successful evacuation. He said that there would be the signal "brace, brace, brace" made over the public address system to alert the cabin occupants to prepare for the landing. At 1541:09, the approach controller again informed the flight that emergency equipment would be standing by.

At 1541:52, the second officer reported that a flight attendant said she observed damage on one wing. He asked if he should go aft and look. The captain authorized his absence from the flightdeck to investigate. The second officer returned about 2-1/2 minutes later to report that there was damage to the tail of the airplane, and the captain stated, "...that's what I thought." At 1548:43, the landing gear was extended. At 1549:11, the captain directed the flightcrew to lock their shoulder harnesses and to put everything away.

At 1551:04, ATC reported that the airplane was 21 miles north of the airport. The controller requested the flight to widen its turn slightly to the left in order to make a turn onto its final approach and to keep the airplane away from the city. The captain responded, "whatever you do, keep us away from the city." Several seconds later, the controller gave the flight a heading of 180°. At 1552:19, the controller alerted the crewmembers to a 3,400-foot tower obstruction located 5 miles to their right. The first officer acknowledged. At 1552:34, the controller asked how steep a right turn the flight could make. The captain responded that they were trying to make a 30° bank. A cockpit crewmember commented, "I can't handle that steep of bank. ..can't handle that steep of bank."

At 1553:35, the first officer stated, "...we're gonna have to try it straight ahead Al..." followed 2 seconds later by the controller advising the crew that if they could hold altitude, their right turn to 180° would put the flight about 10 miles east of the airport. The captain stated, "that's

what we're **tryin'** to do." The first officer then recommended that they try to establish a shallow descent. Twenty seconds later, the captain stated that he wanted to get as close to the airport as possible. Seconds later, he stated, "get on the air and tell them we got about 4 minutes to go." The first officer so advised the controller, but the captain corrected him, saying, "tell the passengers," at which time a crewmember made a PA announcement. At **1555:44**, the captain reported a heading of **180°**. The controller reported that if the altitude could be maintained, the heading, "will work fine for about oh 7 miles."

At **1557:07**, the controller reported to the flight that the airport was ". . . twelve o'clock and one three miles." At **1558:11**, the captain reported the runway in sight and thanked the controller for his help. The captain instructed the second officer to make a PA announcement, which was believed to be a 2-minute warning. The controller reported the winds as **360°** at 11 knots and cleared the flight to land on any runway. At this point, the flightcrew attempted to turn the airplane to the left slightly. At **1558:59**, the captain reported, "we're pretty well lined up on this one here. . . think we will be. . ." The controller, stated that the runway the flight had lined up on was runway 22, which was closed, but he added "that'll work sir, we're **gettin'** the equipment off the runway, they'll line up for that one." The captain asked its length, and the controller reported it as 6,600 feet long. Twelve seconds later, the controller stated that there was an open field at the end of the runway and that the winds would not be a problem. During the interim seconds, the crew's attention was directed to manipulating the throttles. At **1559:29**, one of the crewmembers made the PA announcement to brace for the landing.

At **1559:44**, the first of several ground proximity warning system alerts (GPWS) began and ended 8 seconds later. At **1559:58** the captain stated "close the throttles." At **1600:01**, the check airman stated "**nah** I can't pull'em off or we'll lose it that's what's **turnin' ya.**" Four seconds later, the first officer stated, "left A1" followed by "left throttle" left [repeated several times]. A second series of GPWS alerts began at **1600:09**, followed by the first officer stating several times, "we're turning" or "we're **retryin.**" The sound of the impact occurred at **1600:16**.

#### 1.11.2 Flight Data Recorder

The flight data recorder (FDR) was a Sundstrand Model 573 (S/N 2159). It was found undamaged, and there was no evidence of excessive wear. The quality of the data recording was generally good, although some anomalies in the data did occur. The recorded data included altitude, indicated airspeed, heading, pitch attitude, roll attitude, stabilizer position, fan rotor speed (**N1**) for each engine, vertical acceleration, position of control surfaces, longitudinal acceleration, and lateral acceleration.

The FDR contained a full 25 hours of recorded data. The data for the July 19 Denver-Chicago flight and the previous flights on the tape were transcribed and examined for anything unusual in the **N1** record for the No. 2 engine. All prior recorded engine parameters were normal.

The data revealed no evidence of RPM that exceeded the maximum allowable limit of 111 percent  $N_1$  for flights prior to the accident flight. However, the data did reveal cyclic excursions in  $N_1$  within allowable values on all three engines.

The FDR operated normally until ground impact, except for three periods in which the data stream was interrupted and data were lost. The first loss occurred shortly after takeoff during a track switch within the recorder. The second loss of 44 seconds of data occurred approximately 9 minutes before the No. 2 engine failed. The third loss occurred at the time of the No. 2 engine failure, resulting in the loss of approximately 0.7 seconds of data. The FDR data showed that the No. 2 engine failed at 1516:10.

The FDR data for the conditions that existed just prior to the No. 2 engine failure--the last data point before the failure--were:

Pressure Altitude	36,991 feet
Indicated Airspeed	271.25 knots
Total Air Temperature	-17 degrees C.
Magnetic Heading	82.27 degrees
Pitch Angle	2.812 degrees
Bank Angle	20.04 degrees
Fan Speed, No. 1 engine	102.86 percent <sup>4</sup>
Fan Speed, No. 2 engine	102.69 percent
Fan Speed, No. 3 engine	103.59 percent
Vertical Load Factor	1.0556 g's
Longitudinal Load Factor	(+).0708 g's
Lateral Load Factor	(-).0030 g's

#### 1.12 Wreckage and Impact Information

Farm residents in a rural area near Alta, Iowa, notified authorities shortly after the accident to report that aircraft parts had fallen in their area. The aft fuselage tailcone and No. 2 engine parts, including one-half of the fan forward stator casing or containment ring and numerous smaller pieces, were recovered in a relatively localized region the day after the accident.

Also found near Alta soon after the accident were parts of the tail engine adapter assembly, consisting of adapter ring and bellmouth assemblies, an anti-ice pneumatic tube, a starter air tube, three cowl hold-open rods, two hydraulic system accumulators from the No. 2 engine-driven hydraulic pumps, fan blade fragments, two pieces of insulated metal braid-covered hydraulic hose clamped together, and a segment of aluminum material broken out of the large structural "banjo" forging from the airplane inlet duct structure.

---

<sup>4</sup>Speed is indicated as a percent of a rotor design reference speed. It does not indicate a percent of a rated speed or rated thrust.



*Inflight* photographs taken by observers on the ground near the airport showed that, to the extent visible from the viewing location, the No. 2 engine installation was still intact, except for the right fan cowl door. The engine mounting beam, reversers, and the core cowl appeared structurally intact prior to ground contact at the airport.

About 3 months after the accident, parts of the No. 2 engine fan disk were found in farm fields near Alta. There were two sections that constituted nearly the entire disk, each with fan blade segments attached. These parts were initially taken to the GEAE facility in Evandale, Ohio, for examination under the direction of the Safety Board. The small segment was later transported to the NTSB Materials Laboratory in Washington for further evaluation. (See section 1.16, Tests and Research).

The recovery location of two pieces of the No. 2 engine stage 1 fan disk assembly relative to the radar track suggested that the small segment of the stage 1 fan disk assembly departed the aircraft to the left, and the remainder of the fan disk assembly departed to the right. Trajectory calculations for the separated fan disk assemblies predicted that, with the northerly winds aloft, both pieces of the fan disk assembly would move to the south of the aircraft ground track, where they were actually recovered. (See figure 11).

About 9 months after the accident, farmers in the same area located the front flange of the No. 2 engine rotor shaft and a large section of the fan booster disk. These parts were later examined at the NTSB Materials Laboratory and at other laboratories. (See section 1.16, Tests and Research).

#### 1.12.1 Impact Marks and Ground Damage

The airplane's right wing tip, right main landing gear, and the nacelle for the No. 3 engine contacted the runway during the initial touchdown sequence. The airplane tumbled as it continued down the runway and broke into multiple sections. The airplane skidded off the right side of runway 22 between taxiway "H" and runway 17/35 and through a soybean field. Part of the fuselage and wing section wreckage came to rest in a corn field adjacent to the west side of runway 17/35.

The empennage of the airplane came to rest on its right side against the remaining stub of the right horizontal stabilizer on taxiway "L" near the intersection of runway 4/22 and runway 17/35. Most of the inlet for the No. 2 engine, some of the aft fuselage, a stub of the right inboard horizontal stabilizer, and a part of the vertical stabilizer, just above the engine inlet section, were intact. The separated vertical fin and rudder were located on taxiway "L" just west of the empennage.

The wing center section was found in an inverted position in the corn field and was partially consumed by the postcrash fire. A major portion of the left wing was still attached to the center fuselage. Most of the outboard section of the right wing had separated during the breakup on runway 22. The remainder of the inboard section of the right wing still

# Alta Debris Field-Buena Vista County

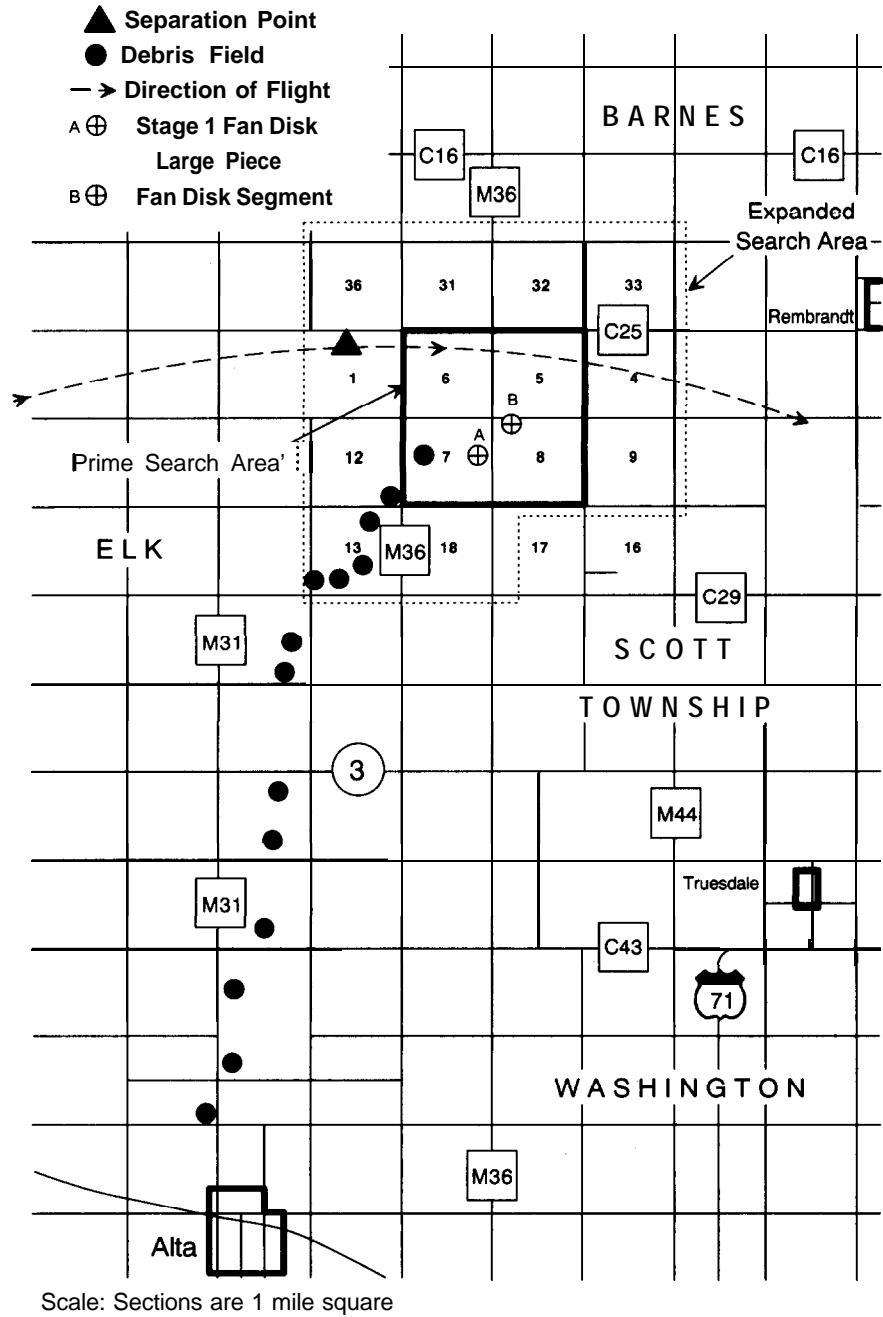

Figure 11. --Trajectory information/Alta debris field.

attached to the center fuselage was heavily damaged by ground impact. The center fuselage section was extensively damaged.

The forward fuselage section, aft of the crew compartment, had separated and was located near the wing center fuselage section. The crew compartment wreckage was located east of runway 17/35 along the main debris path.

The left horizontal stabilizer separated into three main sections. The pieces were found on the northwest side of runway 22. Two of the sections were located approximately halfway between taxiway "H" and runway 17/35.

The right horizontal stabilizer had broken into a number of pieces, which came to rest on both sides of runway 22. The largest piece recovered was a 16-foot outboard section on the left side of runway 22. Most of the leading edge was missing near the tip. Another large section containing the right stabilizer midsection and portions of the inboard and outboard elevators were recovered on the right side of runway 22 along the debris path.

Portions of the No. 2 engine stage 1 fan blades and stage 2 booster blades were found embedded in aircraft sheet metal of the empennage, and two No. 2 engine fan-to-shaft flange nuts were found lodged in the No. 2 intake acoustic panels.

Four punctures on the vertical stabilizer were noted as probable fragment damage prior to ground impact. Documentation of hole/puncture damage to the horizontal stabilizers is contained in Appendix C. There were 79 punctures recorded from fragment damage and one large hole, about the same size as the large piece of recovered fan disk. The flight control surfaces were recovered in the aircraft wreckage and had varying degrees of damage that could have occurred before or after impact.

Examination of the interior of the empennage revealed that, except for the breached hydraulic fluid systems, there was no evidence of precrash damage to the components comprising the flight control systems, hydraulic systems, or the auxiliary power unit.

Due to extensive ground damage to the airplane structure, continuity of the flight control systems after the accident could not be established for all systems. All control system cables and system component separations that were examined were typical of overload failures associated with ground impact and aircraft breakup.

The extension of the horizontal stabilizer actuators were measured and recorded. Their positions were equivalent to a position of 10° airplane noseup. Measurements of other hydraulically powered flight control actuators were not recorded. These actuators do not have mechanical locking devices and are free to rest or float along with the position of their attached control surfaces, when hydraulic pressure is absent.

The No. 1 engine came to rest on the north side of runway 22 just before the intersection of runway 17/35 and runway 4/22. The engine was located about 3,050 feet beyond the initial impact point of the airplane. The fan cowling for the No. 1 engine had separated shortly after touchdown and was in the soybean field to the left of runway 22 and beyond taxiway "I." The engine had impacted the ground at the 12:00 position<sup>5</sup> of the fan module, crushing the forward fan stator case in an aft and radially inward direction into the fan rotor blades. The fan blade airfoils were bent opposite to the direction of rotor rotation.

The No. 3 engine came to rest on the west side of runway 17/35 near the intersection of runway 17/35 and taxiway "L." The engine was located approximately 3,500 feet beyond the initial impact point of the airplane. It had sustained severe ground impact damage. There was no evidence of preimpact damage.

The No. 2 engine came to rest on taxiway "J" to the left of runway 22. The engine was located approximately 1,850 feet beyond the initial impact point of the airplane. It was extensively damaged during the ground impact and from tumbling after it was severed from the empennage.

The upper portion of the aft fan case, upper struts, and the fan frame were still attached to the gas generator core. The aircraft mount beam was still attached to the forward and aft engine mounts. The upper halves of the left and right fan reversers were partially attached at the aircraft mount beam. The exhaust nozzle and centerbody, including the center vent tube, were severely crushed forward into the turbine rear frame. The aft end of the turbine rear frame was also crushed forward over most of its circumference.

The high-pressure compressor cases, the compressor rear frame and the turbine midframe were not visibly damaged. The left quadrant of the upper and lower low-pressure turbine cases were bulging outward in the plane of the stage 5 rotor blades. The stage 5 low-pressure turbine rotor blades were only visible in small regions. In these areas, no contact was observed between the stage 5 blades and the aft side of the stage 5 vanes. The eighth stage bleed air manifolds that were attached to the lower case of the high-compressor stator case were dented.

The aft end of the fan forward shaft, in addition to approximately 20 percent of the shaft cone wall section, remained attached to the engine. Six fragments of the conical section were recovered at the accident site; they represented about 75 percent of the fan forward shaft.

The entire aft fan case with attached fan frame outer struts was recovered at the accident site. Approximately 95 percent of the aft fan stator case was recovered, as well as about 90 percent of the stage 2 fan

---

<sup>5</sup>All clock positions referred to in this report are viewed from aft looking forward (ALF). Viewed in this manner, fan rotation is clockwise.

(booster) inner outlet guide vanes. All of the booster support remained attached to the engine, but the booster **stator** support was heavily damaged.

Seven sectors of the eight-sector booster **midring** shroud were recovered at the accident site and contained approximately 60 percent of the **midring** shroud assembly. All of the sectors were severely deformed and did not show any corresponding evidence of a high-speed rub from the stage 2 booster blades. The shroud sectors displayed irregular rub marks and an **irregular rub** track. One of the larger shroud sectors contained indentations consistent with booster blade tip impressions radiating outward and forward into the shroud.

Two full and one partial segment of the total of eight stage 1 outlet vane sectors were recovered at the accident site. The partial vane sector contained only the inner band and was found within the left horizontal stabilizer.

The No. 1 ball bearing on the **CF6-6** engine is the largest bearing in the engine and is the primary fan support bearing that carries the fan rotor thrust. Fragments from the outer race of the failed engine No. 1 bearing and one bearing ball, in addition to fragments from the No. 2 roller bearing and several intact rollers, were recovered at the accident site. The ball and roller bearings, the raceways and their outer race fragments were not visibly deteriorated and did not exhibit any visual evidence of preaccident spalling or oil starvation.

The fore and aft components of the No. 1 ball bearing housing assembly were recovered at the accident site in front of the No. 2 engine on **taxiway "J."** Both housings (the forward housing was still attached to the largest fragment of the aft housing) had been separated and deformed into a "horseshoe" shape due to radial outward impact at the 1:00 position.

Two large pieces of one sector of the stage 2 disk assembly (booster spool) were recovered at the accident site. One piece of the assembly consisted of approximately 67 percent of the stage 2 disk's circumference. The other piece consisted of about 32 percent of the forward spacer arm.

Eleven fragments of stage 1 fan blades were recovered at the airport either in the left horizontal stabilizer or on the ground. One fan blade fragment containing the dovetail, platform, and inner airfoil section (S/N AMD 11691) was recovered on the left side of runway 22 between the initial touchdown point and the No. 2 engine position on **taxiway "J."** It was determined that it was from blade position No. 10.

Sections of 2 of the 20 fan disk/fan forward shaft retaining bolts were recovered during a search of the accident site. The two recovered bolt sections consisted of the shank and head ends only. The thread ends were missing, and the fracture surfaces appeared to be typical of a combination of shear/bending overload.

Three of the 20 fastener nuts for the fan disk/fan forward shaft retaining bolts were recovered at the accident site. Two of these fan nuts were embedded in the No. 2 engine inlet acoustic panels; the third was recovered in the interior area of the right horizontal stabilizer in hole No. 5.

The right and left core cowls had separated from the pylon at their hinge points. The cowls were found 30 feet from the No. 2 engine and were severely damaged by ground impact. The cowl halves were joined by the lower latches; however, the aft hinge had broken.

The lower right half of the forward fan **stator** case (containment ring) was recovered on the right side of runway 22, approximately 500 feet beyond taxiway "J," and in line with the direction that the empennage had skidded after separating from the fuselage.

#### 1.12.2 Reconstruction of Empennage

The aft fuselage and all identified pieces of the empennage were transported to a hangar at Sioux Gateway Airport for reconstruction (mockup). (See figure 12). The aft fuselage was mounted vertically on a wooden trestle with cables anchoring it to the floor and walls. Lines were strung from the lower surface of the two horizontal stabilizers to the hangar walls to establish the dihedral angles for the horizontal stabilizer reconstruction. The rudder and vertical stabilizer were not used in the reconstruction of the tail. A wooden scaffolding was constructed to support the larger piece of horizontal stabilizer structure, and a wire grid was used to support the smaller pieces. A gallery was constructed around the mockup to aid examination.

Left Horizontal Stabilizer Damage.--All the holes attributed to engine debris damage were examined, and no evidence of severed lines or significant leakage of hydraulic fluid was found.

Right Horizontal Stabilizer Damage.--The outboard elevator had been broken and separated from the outer section of the horizontal stabilizer between the actuator and the inboard damper hinges. Forward of that, the section was broken and had separated on a line parallel to the aircraft centerline from just outboard of the actuator. This section was about 16 feet long. The stabilizer had also separated along a line from between the mid- and inner hinges of the inboard elevator parallel with the aircraft centerline to the leading edge of the stabilizer.

There were three large holes found in the right stabilizer. One hole, located at the outboard leading edge and oriented generally spanwise, extended aft to the front spar; this hole was one of the damaged areas visible in the in-flight photograph taken during the airplane's approach to the airport. Considerable effort was expended to identify the source of this damage; the damage has dimensions similar to the size of the large piece of the fan disk and blades. However, no positive match could be made. A second hole seen in the in-flight photograph was forward of the inboard elevator. Flight control hydraulic components are in this area. The exact

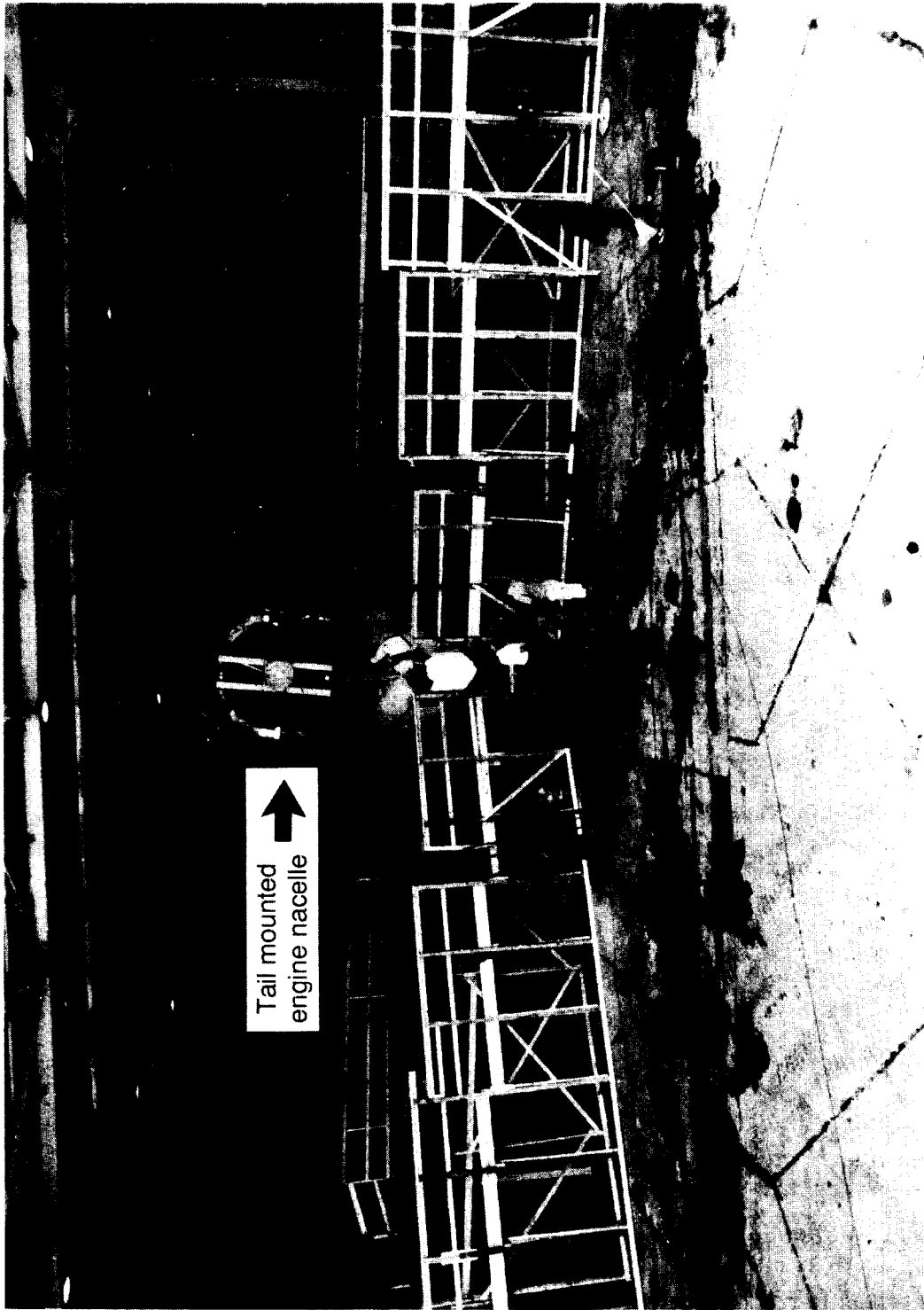

Figure 12.--Reconstruction of the tail section of N1819U.

size and shape of the hole could not be determined because of damage from the ground impact and the breakaway of the stabilizer section outboard of the inboard elevator actuator. A third hole was in the inboard elevator; there are no critical components within this structure.

The remaining smaller holes were examined to determine if they had been caused by engine hardware and to verify elements of the aircraft control systems that had been damaged. The diagram shown in appendix C was prepared.

#### f. 12.3 Damage to Inlet Duct and Vertical Stabilizer Spars (Banjo Frames)

Examination of the tail of the airplane revealed crash damage to the front of the No. 2 engine inlet on the right side and top, and the left side was separated at 9:00. The No. 4 (aftmost) section of the banjo frame was cracked through at 3:30, and the aft edge had separated and had a piece missing from 2:30 to 4:00. A portion of the missing piece was recovered from a farm field in the region of Alta, Iowa, and matched the banjo frame from approximately 3:30 to 4:00. The recovered piece was examined and found to contain titanium alloy smears. The only titanium components liberated in flight were from the fan section of the No. 2 engine.

The longitudinal distance between the engine forward fan stator case and the aircraft No. 4 banjo frame (about 17 inches) is bridged by an engine inlet adapter assembly consisting of two cylindrical panels--the inlet bellmouth, bolted to the front flange of the fan forward casing, and the adapter ring. The assembly is designed to provide clearance to accommodate displacement between engine and airframe.

Two pieces of the bellmouth assembly were recovered near Alta, including the area of 7:00 to 12:00. A large portion of this bellmouth panel was torn away at the bracket stations at 9:00 and 11:30. About 25 percent of the inlet adapter ring was eventually recovered.

#### 1. 12.4 Hydraulic System Damage

During reconstruction of the empennage, it was noted that a portion of the right horizontal stabilizer was not recovered at the Sioux City Airport. A photograph taken from the ground prior to impact shows that this section was missing before impact. The missing area contained the No. 1 hydraulic system tubing that supplies hydraulic fluid to the right inboard and outboard elevator actuators. (See figure 13 and 14).

A fragment of hydraulic tubing assembly with a "T-fitting" attached was recovered from the runway and was identified as part of the No. 1 hydraulic system. The tubing was bent, punctured, and showed evidence of impact damage. Titanium alloy traces were identified on the tubing. Adjacent tubing sections that mated with this "tee" segment were not found.

Examination of the empennage wreckage revealed that the No. 3 hydraulic system pressure line was severed in the inboard area of the right horizontal stabilizer. Holes penetrating the stabilizer skins were found in





Figure 13.--N1819U, view of top surface of right horizontal stabilizer.

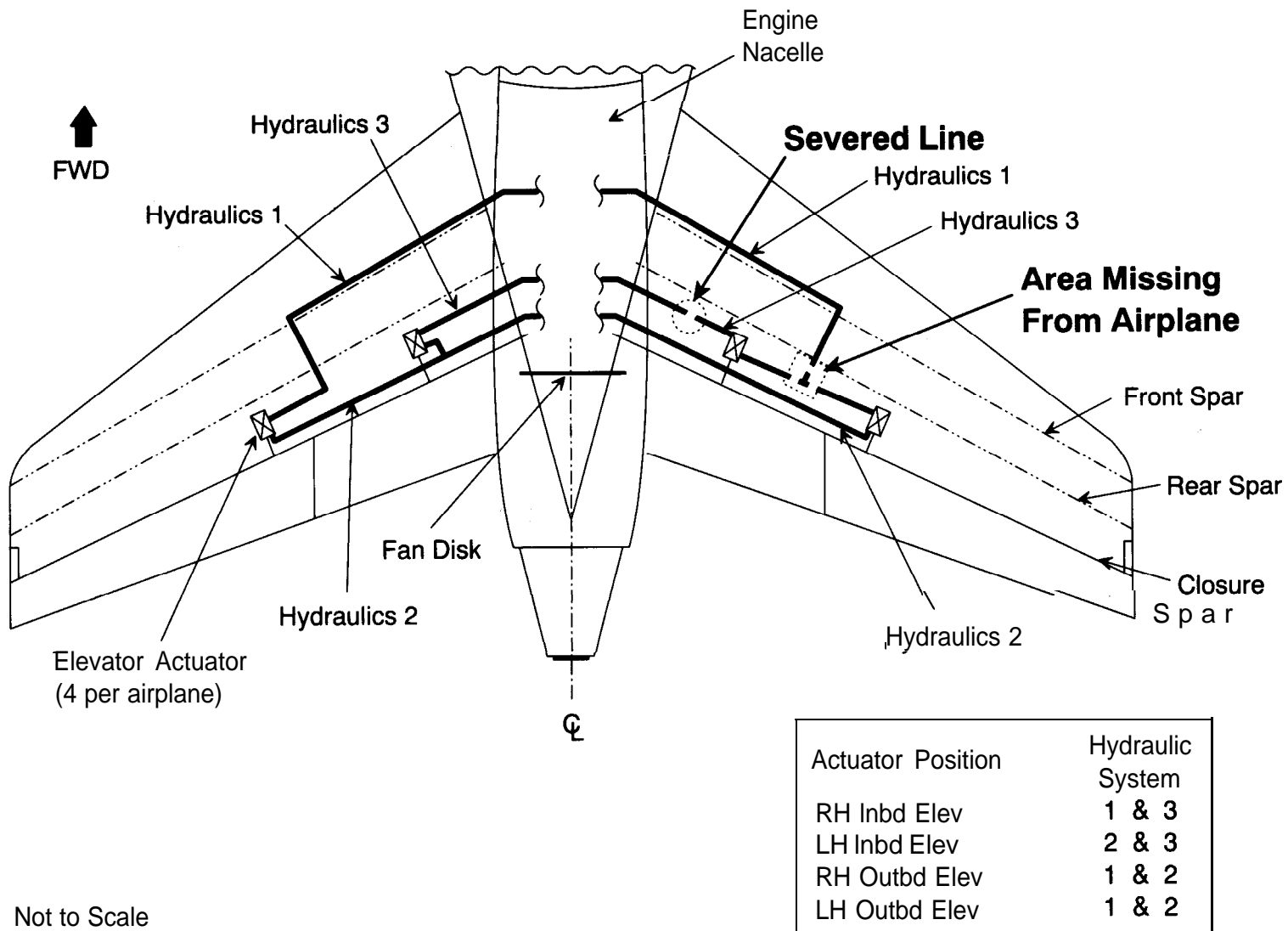

Figure 14. --N1819U, planform of horizontal stabilizer hydraulic system damage.

the upper and lower surfaces in the area of the severed line. The pressure line was severed with a gap of approximately 2.5 inches. The return line had penetrated the horizontal stabilizer and had separated from the adjacent fitting. Material adhering to severed areas of the damaged hydraulic lines of the No. 3 hydraulic system was identified by X-ray energy dispersion examination as titanium alloy. The entry hole where the object passed through the top skin and doubler was 5.5 inches by 2.25 inches and roughly rectangular. The hole size did not match the dimensions of any piece of the stage 1 fan disk; however, the hole size and shape were comparable to the dimensions of a fan blade base platform.

Portions of two insulated-braided hydraulic hoses were recovered near Alta, Iowa, during the on-scene investigation. The hoses were joined by an insulated clamp and were identified as a hydraulic supply and return hose from an engine-driven pump. The hoses recovered near Alta were attached to a No. 2 engine-driven hydraulic pump. Positive identification of the hoses by part number could not be established. However, all supply hoses for the No. 1 and No. 3 engines were accounted for in the wreckage at the airport.

All three hydraulic system reservoirs were examined and found empty. The system 1 and system 2 reservoirs and associated plumbing were found intact and undamaged mounted in their normal positions. The system 3 reservoir and its associated plumbing were found intact with minor blackening from fire damage in their normal positions in the right wheel well.

#### 1.13 Medical and Pathological Information

Of the 296 persons aboard the airplane, 110 passengers and 1 flight attendant were fatally injured. Autopsies revealed that 35 passengers died of asphyxia due to smoke inhalation, including 24 without traumatic blunt force injuries. The other fatally injured occupants died of multiple injuries from blunt force impact. Of the remaining 185 persons onboard, 47 sustained serious injuries, 125 sustained minor injuries, and 13 were not injured. (See figure 15).

#### 1.14 Fire

There was no evidence of in-flight fire. A postcrash fire erupted during the crash breakup of the airplane. A deep-seated fuel-fed fire took place in the cabin wreckage.

##### 1.14.1 Airport Response

The FAA control tower advised the airport fire department of a DC-10 in-flight emergency about 1525. A total of five ARFF vehicles were dispatched. These units were assisted by four Sioux City Fire Department vehicles, which were dispatched to the airport before the crash as part of the community emergency response plan.

During the response, information relayed from the control tower to these units indicated that the airplane might not reach the airport and that it could crash approximately 5 miles south of the airport.

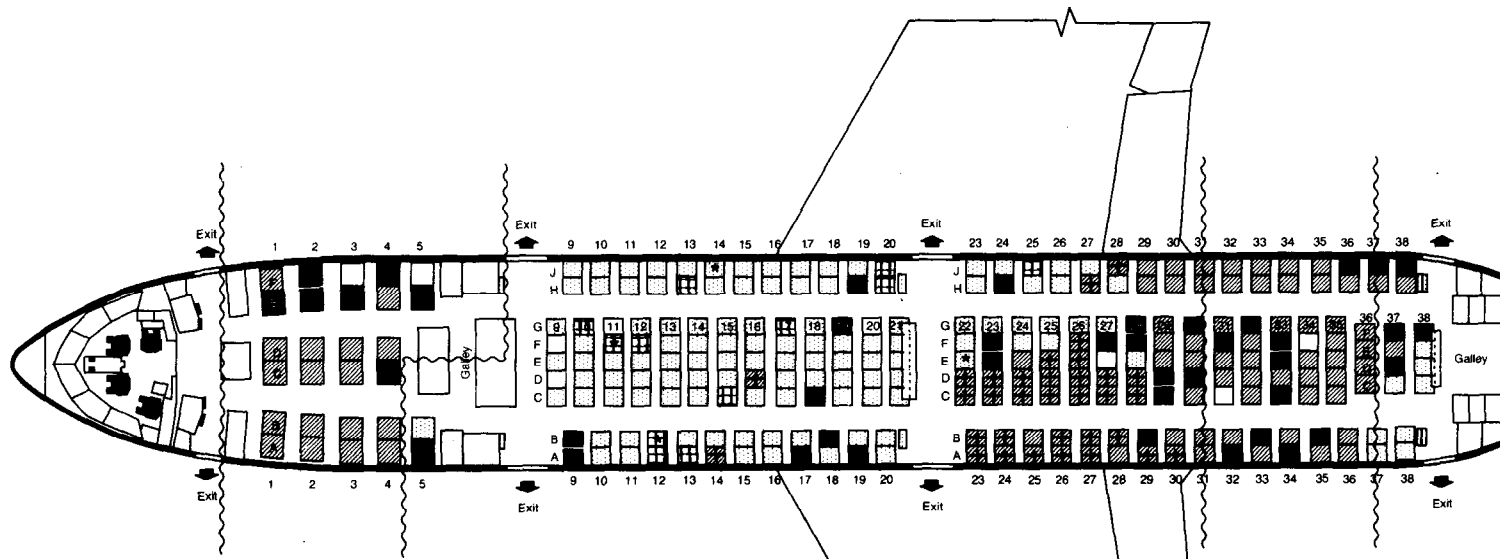

Injury Legend			
	Fatal		Minor
	Fatal (smoke inhalation)		None
	Serious		Unoccupied seat

~~~~~ Approximate breaks in fuselage

|                      |     |                                                                                    |  |     |
|----------------------|-----|------------------------------------------------------------------------------------|--|-----|
| **In-lap occupants** |     | Note:<br>Passenger who was<br>assigned seat 20H<br>moved to an unknown<br>seat. -- |  |     |
|                      | 11F |                                                                                    |  | 14J |
|                      | 12B |                                                                                    |  | 22E |
|                      |     |                                                                                    |  |     |

Figure 15. -- Seating and injury information.

At 1547, the fire chief was advised by the control tower that the airplane was going to reach the airport and that it would land on Runway 31. Firefighting units immediately took positions along runway 31 and awaited the arrival of the airplane.

At 1559, the control tower advised ARFF personnel that the DC-10 would land on runway 22 instead of runway 31. Further, the tower informed the fire chief that some of his vehicles were aligned with the approach path of the DC-10 and that they should be moved immediately.

Before all units were repositioned, the airplane touched down, began to break up, and a fire ignited. The center section, which contained the majority of passengers, was inverted and came to rest in a corn field about 3,700 feet from the initial impact area.

After the crash, all ARFF vehicles proceeded to the intersection of runways 22 and 17, and the fire chief radioed the 185th Tactical Fighter Group Command Post directing all available personnel and equipment to respond to the accident scene.

About 1601, after briefly inspecting the tail section of the airplane, the fire chief directed all units to proceed to the center section of the airplane. While responding to this location, some passengers were found in their seats and others were walking along runway 17.

A significant fire was burning, mostly on the exterior of the wreckage. The fire chief learned from exiting passengers that other passengers could be located among the cornstalks, which were approximately 7 feet high. The emerging passengers later stated that they were disoriented by these tall cornstalks.

The first ARFF vehicle to arrive at the scene sprayed a massive application of foam to blanket the surface of the inverted center section. The fire chief reported that the foam application could easily reach the right wing. Some passengers reported that they were sprayed with foam while exiting the airplane.

The fire chief reported that the fire was located primarily underneath the right wing box area and along the front portion of the fuselage. He said that the 10- to 12-knot wind from the north helped to keep the fire away from the fuselage.

About 1604, the first vehicle to arrive on the scene had exhausted its onboard water supply. By this time, a second vehicle had arrived and commenced a mass application of foam. A 1-inch hand line from the second vehicle was used to attack the right wing box area that could not be reached by the foam. ARFF personnel reported that the hand line attack helped protect passengers exiting from the front portion of the airplane wreckage. About 1610, the second vehicle also exhausted its water supply.

At 1610, while these firefighting operations were in progress, a third unit, a Kovatch P-18 water supply vehicle was brought into position to

resupply the other two units. Water supply lines were connected but, because of a mechanical problem, the P-18 was unable to pump any water to the other vehicles. Consequently, the P-18 was disconnected and, at 1618, Sioux City Fire Department pumpers were positioned to replenish the two primary vehicles. By that time, the fire in the area of the right wing had intensified, spreading to the interior of the airplane. The fire intensified until approximately 1700 and was not brought under control until approximately 2 hours after the crash. Spot fires persisted throughout the night. The fire was suppressed after the application of a total of 15,000 gallons of water and 500 gallons of extinguishing agent.

#### 1.14.2 Off-Airport Response

Following notification by the FAA control tower at 1525, the **Woodbury** County Communications Center in Sioux City began notifying community emergency response organizations. Community agencies included the Sioux City Fire Department (SCFD) and the Police Department, the **Woodbury** County Disaster and Emergency Services, and county/state law enforcement personnel. Responding units included two engine companies and a command vehicle from the fire department and an ambulance from Siouxland Health Services.

At 1534, when the control tower relayed to these units that the airplane would land about 5 miles south of the airport, the vehicles responded by traveling south of the airport on Interstate I-29. At 1538, when the fire chief learned that an attempt was being made by the DC-10 to land on runway 31, the responding SCFD units proceeded to the airport and took a position on a nearby bridge at the I-29 Sergeant Bluff exit to the airport. About 1547, the SCFD emergency responders were advised that the airplane would land on runway 31. The SCFD on-scene commander directed all units to proceed to the airport command post security staging area.

Following the crash, the SCFD assisted fire and rescue efforts. At **1625**, the SCFD Fire Chief became the Site Commander. After the magnitude of the accident became apparent, the call for all available ambulances was made at 1604. Thirty four ambulances responded from more than 28 agencies, some as far away as 60 miles. Additionally, a total of nine helicopters were provided by **Marian** Air Care and military units from Lincoln, Nebraska, and Boone, Iowa. By 1730, all victims had been transported from the airport to the two local hospitals.

#### 1.14.3 The Kovatch P-18 Water Supply Vehicle

When a restriction developed in the P-18's tank-to-pump hose, all water flow stopped to the two ARFF vehicles. Thus, the airport's primary firefighting vehicles could not be replenished to continue attacking the fire. The P-18's tank-to-pump suction hose assembly was removed for further examination.

The examination disclosed that the 2-inch long internal polyvinyl chloride (PVC) stiffener installed in the hose had rotated laterally 90°. Kovatch representatives stated that the internal stiffener in the soft hose assembly is required to prevent the hose from collapsing. They

also stated that the stiffener was installed by a press fit in the center of the hose.

In examining the susceptibility of the internal stiffener to displace and rotate, the Safety Board found that the stiffener's length was about one-half the internal diameter of the soft suction hose. Because of the small size of the stiffener and because it was not clamped, it was free to rotate and block the flow of water or even to slide toward the pump intake, making the soft suction hose susceptible to collapse.

#### 1.15 Survival Aspects

The largest intact section of the airplane was the center portion of the fuselage that contained seat rows 9-30 and the flight attendant jumpseats at doors 2L, 2R, 3L, and 3R. This section came to rest inverted in a corn field and was eventually destroyed by the postcrash fire. The ceiling structure collapsed throughout the fuselage, and the greatest amount of collapse was in the area of the left wing. Thirty-three of the 35 occupants who died from asphyxia secondary to smoke inhalation were, in the section of the fuselage containing rows 22-30. Two other occupants in seats 14A and 16D died of asphyxia due to smoke inhalation.

The tail and a portion of the rear cabin containing 10 passenger seats and 2 flight attendant jumpseats separated early in the impact sequence. With the exception of the tail section, the cabin aft of about row 31 was destroyed by impact.

The cockpit area separated from the fuselage just aft of doors 1L and 1R and was substantially damaged, but the shoulder harnesses and lap belts remained intact and restrained the four occupants who were extricated by ARFF personnel. Most of the first class cabin section was destroyed.

##### 1.15.1 Cabin Preparation

The flight attendants were serving a meal when the No. 2 engine failed. The senior flight attendant was called to the cockpit and was instructed by the captain to secure the cabin and prepare for an emergency evacuation. She did not ask the captain for the amount of time available until the airplane would land. In a later interview, she said that she did not request this information of the captain because she thought the flightcrew was too busy. The senior flight attendant returned to the cabin and separately instructed six of the seven flight attendants to stow food service items and to secure the cabin in preparation for an emergency landing. She related that she did not notify the passengers because she wanted to keep things "normal" as long as possible and did not want to alarm them.

The senior flight attendant related that she was told by the second officer, after he had gone to the rear of the cabin and observed damage on the tail, that the passenger briefing was going to be a "quick and dirty." [This comment refers to the abbreviated passenger briefing in lieu of a longer and more detailed briefing.] The flight attendant stated that when

she received this information, the flight attendants in the aft cabin were still retrieving meal trays. Survivors related that the captain's announcement to the passengers at 1545 stated that the flight attendants had briefed the passengers about the brace position. However, the passengers had not yet been briefed about the emergency cabin preparations. The senior flight attendant began reading the "Short Notice Cabin Preparation" briefing after the captain concluded his announcement.

The Short Notice Emergency Landing Preparation directed flight attendants to be seated in their jumpseats. However, the flight attendants were standing at their demonstration positions when the briefing was read; they subsequently assisted passengers in their briefing zones. Flight attendants gave brace-for-impact instructions to parents of infants and small children. They assisted small children in passenger seats by providing pillows as padding to tighten adult lap belts. For example, a 32-month-old boy seated in 17G was given pillows to tighten his seat belt. He remained restrained during the impact sequence and was not injured.

All of the flight attendants and passengers were in a brace-for-impact position when the airplane landed.

#### 1.15.2 Infants

There were four in-lap occupants onboard flight 232.<sup>6</sup> Three of them were under 24 months, and one was 26 months old. During the preparations for the emergency landing, parents were instructed to place their "infants" on the floor and to hold them there when the parent assumed the protective brace position. The four in-lap occupants were held on the floor by adults who occupied seats 11F, 12B, 14J and 22E.

The woman in 14J stated that her son "flew up in the air" upon impact but that she was able to grab him and hold onto him. Details of what happened to the 26-month-old child at 12B during the impact sequence are not known, but he sustained minor injuries. The mother of the 11-month-old girl at 11F said that she had problems placing and keeping her daughter on the floor because she was screaming and trying to stand up. The mother of the 23-month-old at 22E was worried about her son's position. She kept asking the flight attendants for more specific instructions about the brace position and her "special situation with a child on the floor." The mothers of the infants in seats 11F and 22E were unable to hold onto their infants and were unable to find them after the airplane impacted the ground. The infant originally located at 11F was rescued from the fuselage by a passenger who heard her cries and reentered the fuselage. The infant held on the floor in front of seat 22E died of asphyxia secondary to smoke inhalation. The Safety Board addressed the infant restraint issue in Safety Recommendations A-90-78 and A-90-79 issued May 30, 1990.

---

<sup>6</sup>14 CFR 121.311 allows occupants who have not reached their second birthday to be held in the laps of an adult.



## 1.16 Tests and Research

### 1.16.1 Design of **CF6-6** Engine Stage 1 Fan Disk

Figure 16 shows a drawing of a **CF6-6** engine fan rotor assembly, most of which departed the No. 2 engine of the accident airplane in flight. The assembly consists of the large stage 1 disk and attached fan blades and retainers, the smaller stage 2 disk and attached blades, the spinner cone and cover, and various mounting and balancing hardware. A cutaway view of the engine in the area of the stage 1 disk is shown in figure 17.

The stage 1 fan disk weighs 370 pounds and is a machined titanium alloy forging about 32 inches in diameter. GEAE convention refers to various portions of the disk as the rim, the bore, the web, and the disk arm, as labeled in figure 17. The rim is about 5 inches thick and is the outboard portion of the disk. The rim contains the axial "dovetail" slots, which retain the fan blades. Also, the stage 2 fan disk is bolted to the aft face of the rim. The bore is about 3 inches thick and is the enlarged portion of the disk adjacent to the 11-inch-diameter center hole. Extending between the rim and bore is the disk web, which is about 0.75 inch thick. The conical disk arm extends aft from the web at a diameter of about 16 inches. The conical arm diameter decreases in the aft direction to about 10 inches at the disk arm flange where the disk bolts to the fan forward shaft (also labeled in figure 17).

The primary loads imposed on the stage 1 fan disk are radially outboard loads in the dovetail slots. These loads arise from the disk holding the fan blades against centrifugal forces during rotation of the assembly. The loads imposed by the fan blades result in radial stresses in the disk rim. The radial stress generally decreases toward the bore and are supplanted by circumferential (hoop) stresses. Radial stresses are zero at the bore because there is no material inboard of this location to resist the stress. However, the hoop stresses are greatest along the inside diameter of the bore. Because the disk arm acts to strengthen the aft face of the disk, the area on the disk that experiences the maximum hoop stress is the forward corner of the bore.

### 1.16.2 Examination of No. 2 Engine Stage 1 Fan Disk

In mid October 1989, about 3 months after the accident, two pieces of the No. 2 engine stage 1 fan disk, with attached blade pieces, were found in corn fields near Alta, Iowa. The two pieces comprised the entire separated disk, with the exception of one dovetail post, which was not recovered. Figure 18 shows the **reconstructed** pieces of the disk after the larger disk piece had been cut during the metallurgical evaluations. The gap between the smaller and larger piece does not represent missing material but is a result of **mechanical** deformation that occurred during the disk separation. The disk contained two principal fracture areas, resulting in about one-third of the rim separating from the remainder of the disk. One of the fracture areas progressed largely circumferentially through the web and rim. The other was on a near-radial plane, progressing through the bore, web, disk arm, and rim. Features on the circumferential fracture were

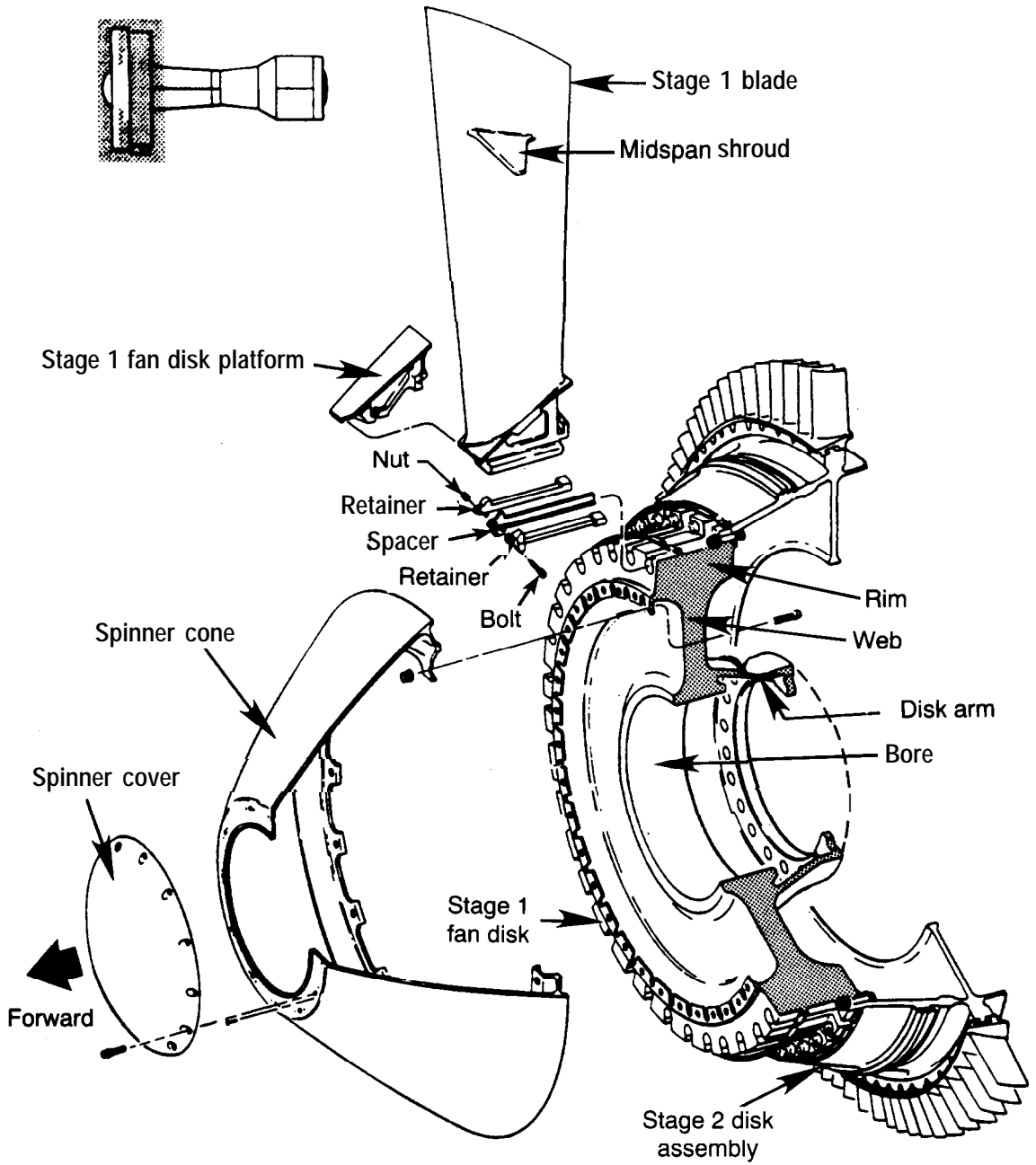

NOTE: Stage 1 fan disk highlighted

Figure 16. --Fan rotor assembly.

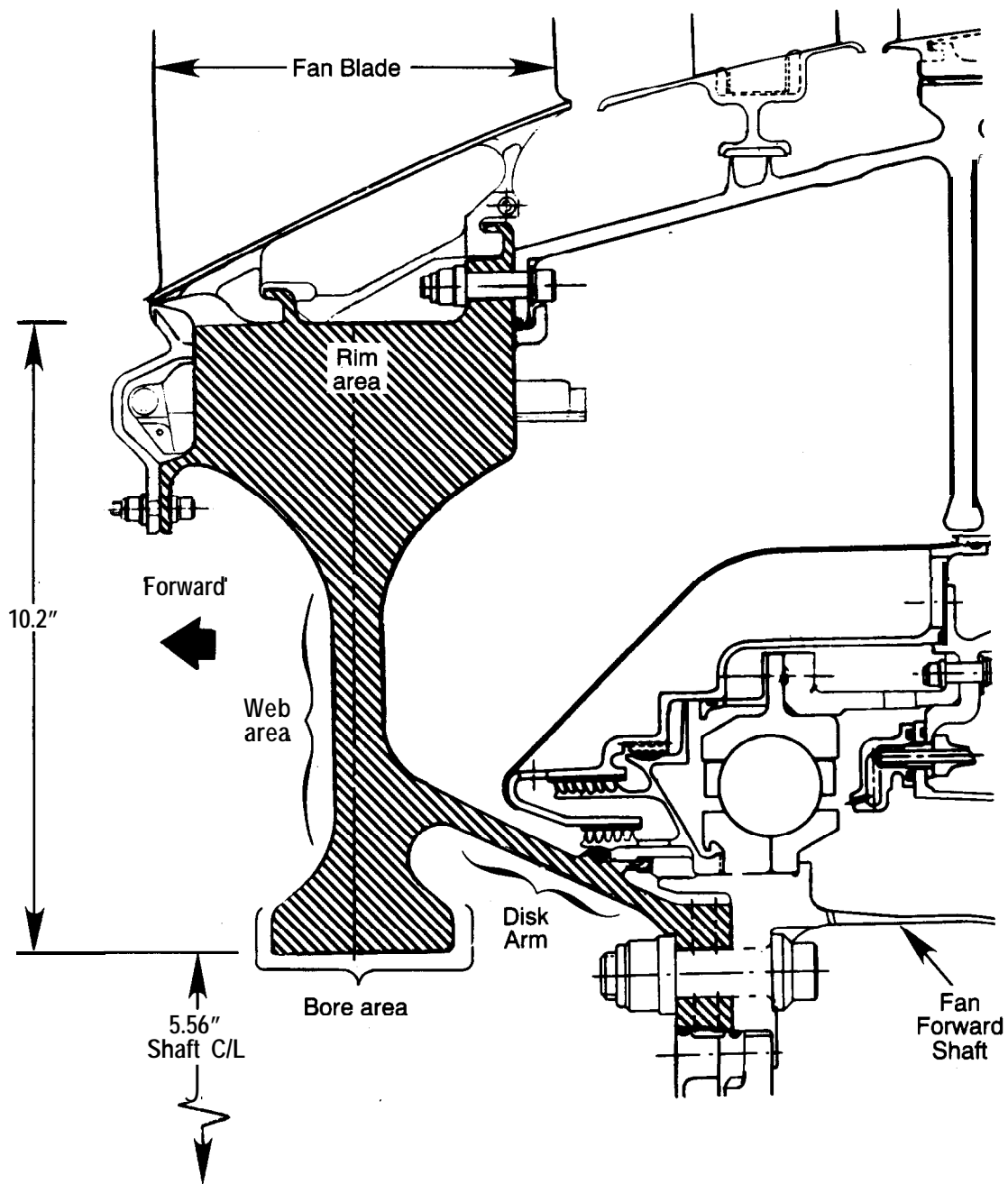

Figure 17.--CF6-6 engine stage 1 fan disk cutaway view - disk highlighted.

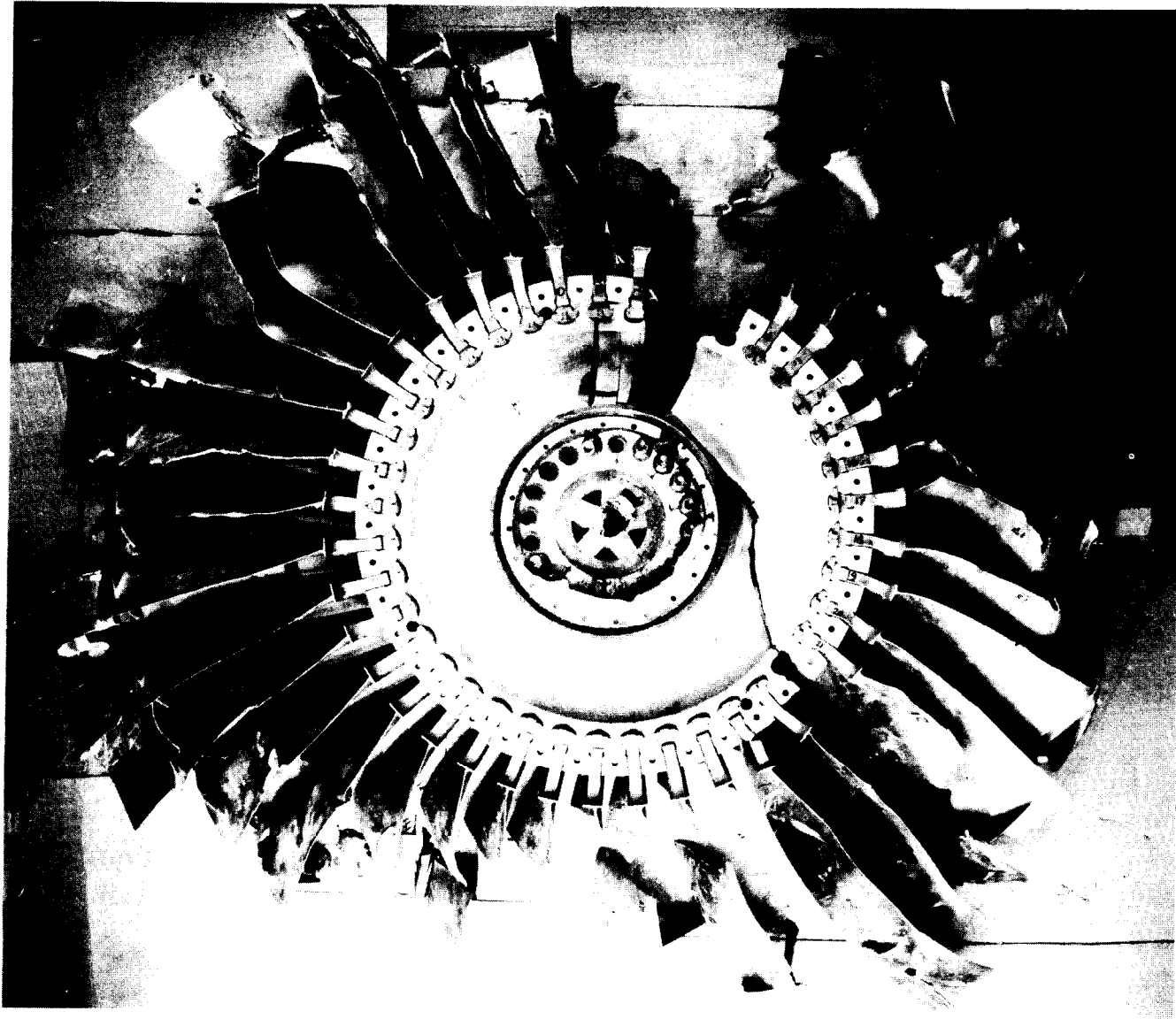

Figure 18. -- No. 2 engine stage 1 fan disk (reconstructed with blades).

typical of an overstress separation stemming from multiple origin areas in the radius between the disk arm and the web. The near-radial fracture surface also contained overstress features over most of its surface. However, on this break the overstress features stemmed from a preexisting radial/axial fatigue crack region in the bore of the disk. Figure 19A shows the fatigue region on the bore.

Metallurgical evaluation revealed that the fatigue crack initiated near a small cavity on the surface of the disk bore, about 0.86 inch aft of the forward face of the bore. Figure 19B is a close view of the cavity. A portion of the fatigue crack around the origin area was slightly discolored. The topography of the fracture surface in the fatigue zone was the same outside the discolored area as it was inside the discolored area. The following table lists overall sizes of the fatigue crack, the discolored area, and the cavity.

|                 | <u>Axial length</u> | <u>Radial Depth</u> |
|-----------------|---------------------|---------------------|
| fatigue zone    | 1.24 inch           | 0.56 inch           |
| discolored area | 0.476 inch          | 0.180 inch          |
| cavity          | 0.055 inch          | 0.015 inch          |

The width of the cavity (measured across both mating fracture surfaces) also was 0.055 inch.

Fractographic, metallographic, and chemical analysis examinations of the fatigue region revealed the presence of a nitrogen-stabilized hard alpha inclusion around the cavity. The microstructure of the core of the inclusion consisted of stabilized-alpha structure (structure with an elevated hardness, excessive nitrogen, and devoid of transformed beta structure) that extended slightly outboard of the cavity (to a maximum radial depth of 0.018 inch from the inside diameter of the bore) and over an axial length of at least 0.044 inch. Altered microstructure associated with the inclusion extended significantly beyond the area containing only stabilized alpha structure, gradually blending into the normal microstructure, a mixture of approximately equal amounts of alpha structure and transformed beta structure.<sup>7</sup> The altered microstructure region was elongated in the axial direction (along the local grain flow direction), but primarily aft of the stabilized-alpha region.

The stabilized-alpha inclusion contained microcracks that were generally oriented parallel to the cavity surface. Also, microporosity was found in the altered microstructure around the core of the inclusion.

The mating fatigue regions on the pieces of the separated stage 1 fan disk were subjected to scanning electron microscope examinations. Some areas of fatigue striations were found just outboard of the stabilized-alpha

---

<sup>7</sup>Alpha and beta are names given to two differing microstructural phases in titanium alloys. In Ti-6Al-4V, these two phases are present in approximately equal amounts.

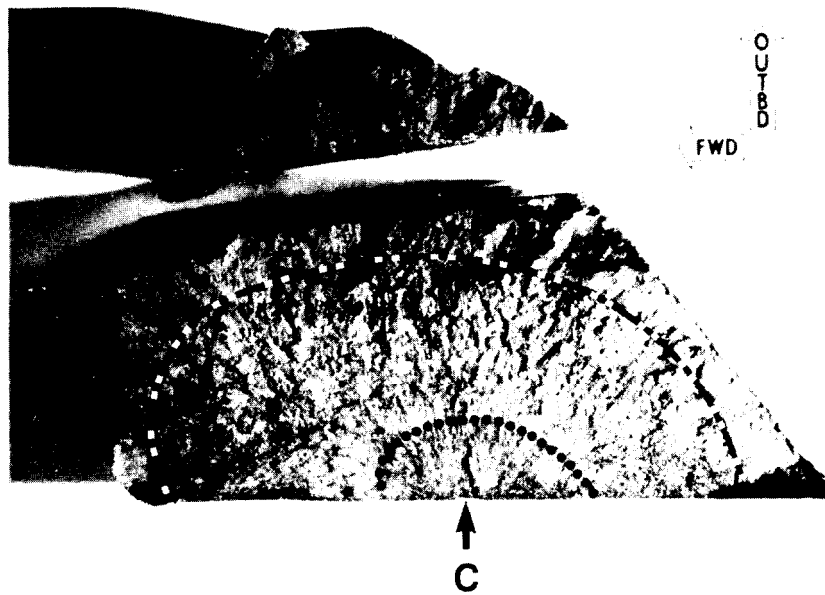

Figure 19A.--Fatigue crack fracture area cut from the bore of the smaller piece of the separated stage 1 fan disk. The fatigue crack extends from the cavity (arrow "C") to the dashed line position. The discolored portion of the fatigue crack is between the cavity and the dotted line. Magnification: 2.26X.

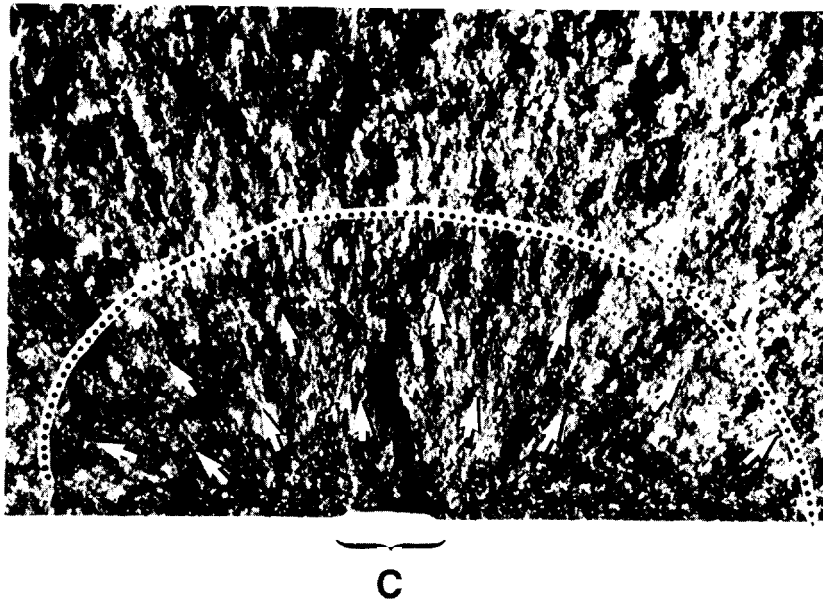

Figure 19B.--Closer view of the discolored area on the fatigue crack. The dotted line in this figure corresponds to the dotted line in figure 19A. Arrowheads on the fracture surface indicate cracking directions away from the cavity. Magnification: 8.6X.

portion of the inclusion at the fatigue origin. However, between the cavity bottom and a radial distance of 0.025 inch outboard of the bore surface, areas with brittle fracture features and a lack of fatigue striations were found intermixed among more ductile-appearing bands with fatigue striations. The zone with a mixture of brittle features and fatigue striation areas correlated with the enriched alpha microstructure surrounding the stabilized-alpha core of the inclusion.

The fatigue striation spacing generally increased as distance from the origin area increased. However, starting at a distance of about 0.145 inch outboard of the bore surface, areas with much more closely spaced striations were also found. The more closely spaced striations were referred to as minor striations, and the striations with wider spacings were referred to as major striations.

The total number of major striations along a radially outward direction from the origin area was estimated by graphically integrating a plot of the striation density versus distance. The estimate correlated reasonably well with the total number of takeoff/landing cycles on the disk. The striations indicate fatigue crack growth since early in the life of the disk.

#### 1.16.3 Examination of Containment Ring

The fan forward stator case (containment ring) is 86 inches in diameter and has an axial length of 16 inches. It is a stainless steel hoop that surrounds the stage 1 fan disk blades. The ring is designed to absorb energy on the order of that associated with release of one fan blade and adjacent damage.

The containment ring from the No. 2 engine was separated at the 1:45 and 7:30 positions. The upper-left piece of the ring departed the airplane in flight and was recovered near Alta. The lower right half of the ring remained with the airplane and was recovered at the wreckage site at Sioux City.

Examination of the 7:30 separation area on the ring pieces revealed deformation and fan blade retainer witness marks that indicated that the smaller piece of the stage 1 fan disk burst through the ring at this location.

Examination of the containment ring separation at the 1:45 position revealed features typical of a tensile overstress separation.

#### 1.16.4 Other No. 2 Engine Hardware

Metallurgical examination of the pieces of the fan forward shaft, the booster disk, the No. 1 ball bearing and bearing support, and other components of the engine revealed fractures and deformation consistent with initial separation of the stage 1 fan disk. The damage patterns on these components and the containment ring indicated that the smaller piece of the

disk departed the airplane to the left and the larger piece departed to the right.

#### 1. 16. 5 Sister Fan Disks

GEAE and ALCOA records indicate that eight fan disks were produced from the same titanium ingot as the separated fan disk. Six of these fan disks (S/N MPO 00382, 00383, 00384, 00386, 00387 and 00388) were in service at the time of the accident and they were recalled to GEAE for testing. The tests consisted of immersion-ultrasonic and surface macroetch. The results of these studies indicate that fan disks No. MPO 00388 and MPO 00382 had rejectable anomalies, as follows:

Fan Disk Serial Number MPO 00388 - Fan disk S/N 388 contained a rejectable ultrasonic indication found by means of immersion-ultrasonic in the web area of the disk. Macroetch indications were noted in the web area coincident with the ultrasonic indication. In addition, macroetch indications were identified in the bore and spacer arm flange area. Metallurgical evaluation of the ultrasonic indication revealed the presence of a nitrogen-stabilized hard alpha inclusion similar to the inclusion found at the origin of the fatigue crack on the separated disk, S/N MPO 00385. The area containing this hard alpha inclusion displayed multiple microcracks oriented in various directions. There was, however, no evidence of fatigue crack propagation from this area. The coincident macroetch indications were determined to be areas of chemical segregation within the disk and displayed local chemistries not in conformance with the GEAE material specifications.

Fan Disk Serial Number MPO 00382 - Immersion-ultrasonic inspection of fan disk S/N 382 was completed without any rejectable indications being detected. The separate ultrasonic inspection of the dovetail posts revealed no rejectable indications. However, the blue etch anodize macroetch inspection detected indications typical of chemically segregated areas. A light etching indication approximately 0.65 by 0.060 inch extended between two bolt holes on the forward face of the disk arm flange. A second indication area composed of two small, thin, dark etching indications (0.38 inch and 0.25 inch) was observed on the aft face of the disk arm flange.

Fan Disk Serial Numbers MPO 00387 and MPO 00383 - Fan disks S/N 387 and S/N 383 completed the immersion-ultrasonic inspection and macroetch inspection procedures without any defect indications noted.

Fan Disk Serial Number MPO 00386 - Immersion-ultrasonic inspection of this fan disk showed several indications below the rejection limit. The indications were situated near the



forward face of the disk bore. However, a macroetch inspection of disk S/N 386 and a metallographic evaluation of the indication area revealed no evidence of material flaws. The ultrasonic indications in this disk are consistent with prior cases where no material flaw was found on subsequent destructive evaluation.

Fan Disk Serial Number MPO 00384 - This disk completed the dovetail post ultrasonic inspection and partially completed the immersion-ultrasonic inspection prior to being sectioned to evaluate the disk forging grain flow and microstructure. No indications were detected with either ultrasonic procedure. Blue etch anodize (BEA) macroetch inspection of the disk, accomplished after sectioning, did not reveal any indications typical of chemical segregation, but areas on the pressure face of three adjacent disk posts were characterized as typical of microstructure overheated during forging.

#### 1. 16. 6 No. 2 Engine Fan Disk Fracture Surface Chemical Residue Examination

Analytical procedures were developed to examine the smaller piece of the disk to determine if chemical residues from the UAL inspection with FPI were present on the fatigue fracture surface. The fracture surface was gently washed initially with deionized water and later with an ultrasonic washer using deionized water. Secondary Ion Mass Spectroscopy (SIMS) measurements on the fatigue fracture surface after the initial washing showed an ion fragmentation pattern that was consistent with chemical compounds used in the FPI fluid, ZL-30A. These compounds were identified as 2-ethylhexyl diphenyl phosphate, decyl diphenyl phosphate, and triphenyl phosphate.

Gas chromatograph (GC)/mass spectroscopy (MS) measurements of the hexane extract of the water used in the ultrasonic washing indicated the presence of triphenyl phosphate and 2-ethylhexyl diphenyl phosphate in the wash water. The presence of these two compounds was confirmed by GC retention time and by electron impact and chemical ion impact mass spectroscopy. Triphenyl phosphate, 2-ethylhexyl diphenyl phosphate, and decyl diphenyl phosphate are present in Santicizer 2024 which is used in the FPI fluid, Z-30A (used to inspect the disk). Engine oil, which contains tritolyl phosphate, was eliminated as a source of the chemical residues on the fracture surface. This phosphate, used as an oil additive, produced a mass spectrum that was different from that of the Santicizer 2024.

#### 1. 17 Additional Information

##### 1. 17. 1 Fan Disk Manufacturing Processes and Hard Alpha

There are three primary steps in the manufacturing of titanium alloy fan disks--material processing, forging, and final machining. In the first step, raw materials are combined in a heat (quantities of alloy source materials melted at the same time; heats are numbered for recordkeeping purposes) and processed into a titanium alloy ingot (after the final melting operation, the heat of metal is referred to as an ingot). The ingot

is formed during furnace melting operations. The ingot is then reformed into a billet (an ingot after it is mechanically elongated and reduced in diameter) for further processing. The second step involves cutting the billet into smaller pieces (forging blanks) that are then forged into geometrical shapes. The last step involves machining the forged shape into the final part shape.

Titanium alloys can exhibit three major types of melt-related anomalies: 1) Type I hard alpha inclusions, 2) high-density inclusions, and 3) segregation (Type II alpha segregates or beta flecks).

Most of the Type I hard alpha inclusions observed in production materials result from localized excess amounts of nitrogen and/or oxygen that have been introduced through atmospheric reactions with titanium in the molten state. A typical hard alpha inclusion contains an enriched alpha<sup>8</sup> zone in the alpha plus beta matrix; voids or cracks are commonly associated with the hard, brittle alpha phase inclusion. Hard alpha inclusions have a melting point significantly greater than the normal structure.

To promote melting or dissolution of hard alpha inclusions, it is desirable either to increase the temperature of the molten pool in the furnace or to increase the time during which the material is in a liquid state. Successive melting operations, such as double or triple vacuum melting, provide additional opportunities for dissolution of hard alpha inclusions but do not guarantee their complete dissolution.

Over the years, research has shown many potential sources for hard alpha inclusions in traditionally processed titanium materials. The major sources of these inclusions are considered to be: 1) contaminated input materials (sponge material exposed to a fire, or torch-cut revert material that has been insufficiently cleaned to remove the torch-cut surfaces), 2) contaminated welding operations, such as welding of electrodes or electrodeholders/stubs, 3) improper conditions during the vacuum melting cycle, including possible drop in of contaminated material or furnace leakage, and 4) inadequate cleaning of the surface of the solidified ingot, particularly after the first melt.

In 1970 and 1971, as a result of separations of titanium alloy rotating engine parts with hard alpha inclusions, GEAE teams visited domestic and foreign titanium melting sources, titanium sponge producers, master alloy producers, and forging sources to determine possible improvements to process parameters and controls. Typical items reviewed by the teams included electrode welding, sponge processing and inspection, revert material control, master alloy production, and melting controls. According to GEAE, qualification of all titanium melters to meet new specifications for premium quality triple-vacuum-melted titanium forgings was accomplished in 1971.

---

<sup>8</sup>Areas with a significant amount of alpha phase are referred to as alpha-rich areas or as an alpha inclusion. If the element causing the excessive alpha phase is nitrogen, hardness is increased and the resulting brittle area is referred to as a nitrogen-stabilized hard alpha inclusion.

Also in 1971, the CF6-6 stage 1 fan rotor disk engineering drawing was changed to specify premium quality triple-vacuum-melted Ti-6Al-4V. All the fan disks manufactured after January 1972 were made in accordance with the new triple-melt material requirements.

The current revision of the GEAE specification for fan disk material contains an additional class of material that allows material to be melted by hearth melting, plus vacuum-arc remelting (VAR) processes. This newly introduced hearth melting process is intended to significantly increase the probability of the dissolution of any hard alpha inclusions that are present in the raw material.

Billet diameter for use in forging fan disks was reduced from the 16-inch diameter used by ALCOA to produce fan disks in 1970 and from the 13-inch and 14-inch-billet diameter subsequently used by Wyman Gordon to produce these components. Current billet diameter specified for CF6 model engine fan disks is 10 inches. This smaller diameter allows a more sensitive immersion-ultrasonic inspection of the billet. Also, according to GEAE personnel, the smaller billet diameter may increase the propensity during forging for cracks or voids to form around hard alpha inclusions, thereby increasing the likelihood that defects can be detected during subsequent ultrasonic inspections.

#### 1. 17. 2 ALCOA Forging and Records

At the time the accident fan disk was produced, titanium alloy ingots/billets were manufactured by several companies, including Titanium Metals Corporation (TIMET) and Reactive Metals Incorporated (RMI).

Records indicate that the separated fan disk involved in the accident was forged by Aluminum Company of America (ALCOA). ALCOA had subcontracted with Titanium Metals Corporation of America (TIMET) to supply raw material in billet form. GEAE specifications at that time required double-vacuum melting of the ingot. ALCOA was also processing titanium alloy billets from RMI and other suppliers.

ALCOA records show that the heat from which fan disk serial number MPO 00385 originated was TIMET heat number K8283, melted on February 23, 1971. Shortly after heat K8283 was produced, GEAE changed its material specification to require triple-vacuum melting. This change went into effect at such time that disks manufactured from heat K8283 were the last CF6-6 stage 1 fan disks produced from material made using the double-melt process.

TIMET records indicate that heat K8283 was made primarily from titanium sponge. Also included in the heat was recycled Ti-6Al-4V alloy, ends of other heats, and other alloy elements. TIMET used Lake Mead water, which contains a significant sulfur content, to process titanium at its Henderson, Nevada, facility. The use of this water reportedly results in titanium material with sulfur levels higher than the levels in titanium made by other producers. TIMET also used a phosphoric acid cleaning procedure that reportedly introduced phosphorous into its titanium in amounts significantly greater than the amounts of other producers.

Melting of the heat K8283 ingot was accomplished using the double-vacuum-melting process. In this process electrodes, consisting of welded titanium briquettes of the required final composition, are melted in a vacuum chamber by striking an arc to the electrode. After the initial melting, the ingot is allowed to cool, then is removed from the melt chamber, inverted and remelted using the same method. After the second melting, heat K8283 ingot was 28 inches in diameter and weighed approximately 7,000 pounds. The ingot was then shipped to the Toronto, Ohio, TIMET facility for conversion to a 16-inch-diameter billet form.

All the billet surfaces were ground, and the ingot was contact ultrasonic inspected per written TIMET procedure. Based on the results of TIMET'S ultrasonic inspection, the top 6.5 inches of material from the billet was removed and discarded, and the remainder of the billet was accepted as having passed ultrasonic inspection.

The entire billet product, net weight 6,208 pounds, including top and bottom test slices, was shipped to ALCOA, Cleveland, Ohio, along with certificates of tests, certifying the acceptability of the materials to the requirements of the GEAE specifications. The TIMET sales order to ALCOA was dated March 26, 1971.

ALCOA records show that this heat of material was assigned a lot number, and eight forging blanks, each weighing approximately 700 pounds, were cut from the billet. The blanks were identified from the top to the bottom of the billet as serial numbers 599-1 through 599-8, corresponding to forging serial numbers AJV 00381 through AJV 00388.

It has been many years since ALCOA was involved in processing fan disks for GEAE. Records retained at ALCOA did not provide information on how the material's traceability was maintained through the preforming steps, blocker forging, finish forging, heat treatment, and machining. Visits to the facility indicated that information on the shop traveler records was correlated to marker crayon indications on the parts as a method to separate lots during processing.

ALCOA forging processes required that a test ring be removed at the bore location of each forging and tested to certify that the room temperature tensile strength and notched stress rupture life met requirements. ALCOA typically certified microstructure, alpha phase, and hydrogen content on one forging from each process lot. Test values for the forgings certifying acceptable tests to the requirements of GEAE specifications were required to be provided by ALCOA to GEAE. These records could not be located during the Safety Board's records examination, nor were they required to be retained for this length of time. ALCOA records indicate initial shipment to GEAE of forgings from heat K8283 in May 1971.

During the accident investigation, ALCOA provided a listing of all CF6-6 fan disks manufactured, showing the heat numbers and serial numbers. This list was used, in conjunction with the listing provided by TIMET, to identify heats of Ti-6Al-4V that contained raw materials from the same feedstocks as heat K8283.

## 1. 17. 3 GEAE Fan Disk S/N MPO 00385 Machining and Finishing Records

During the records search for the manufacturing routing package of stage 1 fan disk S/N MPO 00385, it was learned that two rough machined forgings<sup>9</sup> (referred to as disk "A" and "B") having this same serial number had been routed through GEAE manufacturing. Actual receiving documentation at GEAE could not be located. Figure 20 depicts the three shapes of the disk during the manufacturing process.

Production records indicate that GEAE performed an immersion-ultrasonic inspection of a disk S/N MPO 00385 (disk "A") on June 7, 1971. The record of inspection is dated June 23, 1971. The part was rejected for an unsatisfactory ultrasonic indication. Under procedures in effect at the time, it should have been put aside in a specified storage area pending disposition. No other manufacturing records were found that documented a disk Serial No. MPO 00385 in the manufacturing process between June and September 1971. Correspondence and shipping records indicate that disk "A" was shipped on January 7, 1972 to an outside ultrasonic test laboratory, CONAM Inspection, Inc., Columbus, Ohio. GEAE sought an independent verification of the ultrasonic indication. The existence, location, and amplitude of the ultrasonic indication were verified by CONAM. Records from the two inspection sources are provided in the following table.

Comparison of Ultrasonic Inspection Results,  
S/N MPO 00385

| <u>Inspection Site</u>        | GE            | CONAM                  |
|-------------------------------|---------------|------------------------|
| <u>Date on Insp. Record</u>   | 6/23/71       | 1/31/72                |
| <u>U/S Indication</u>         |               |                        |
| Dist. From Aft Flg.           | 4 inches      | 4 inches               |
| Clock Pos. from S/N           | 11:30 o'clock | 11:30 o'clock          |
| Depth                         | 2-3/4 inches  | 3-1/4 to 3-7/16 inches |
| Circumf. Length               | 3/8 inch      | 3/16 inch              |
| Signal strength<br>(at 12 dB) | 50% of max.   | 60% of max.            |
| Angle, radial shear           | 20°           | 25°                    |

CONAM shipping records showed that disk "A" was returned to GEAE-Evendale on January 31, 1972. It remained at GEAE and was reportedly scrapped and cut up for examination on November 1, 1972. Records of sectioning and microscopic examination of the ultrasonic indication disclosed only macrostructural features in the area of the indication. No evidence of a hard alpha inclusion, or other defect was found. There is no record of any

---

<sup>9</sup>To facilitate discussion within this Safety Board report, the first disk S/N MPO 00385 to appear in the records is described as disk "A." The second disk S/N MPO 00385 to appear in the records is described as disk "B."

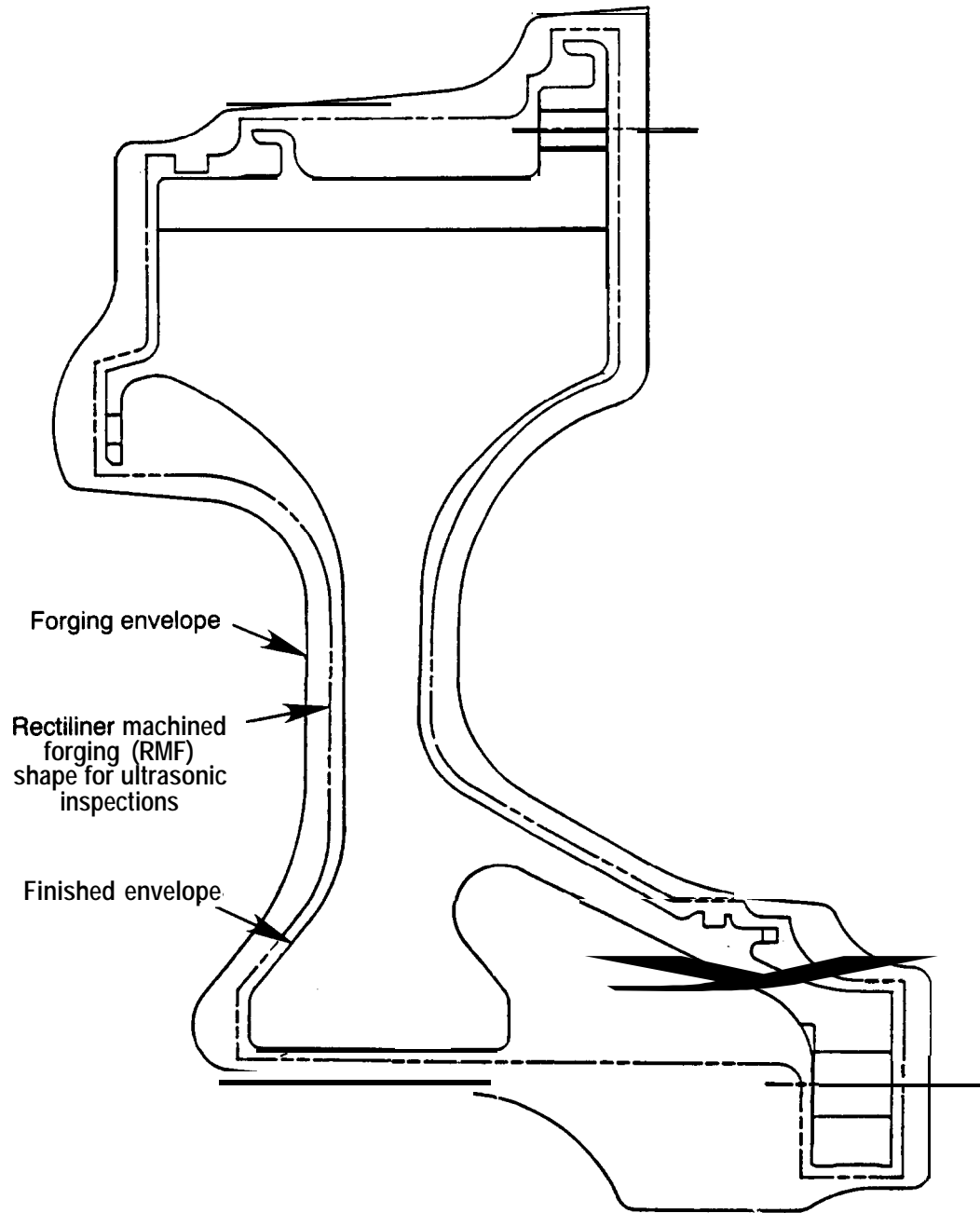

Scale approximately one-half actual size

*Figure 20. --CF6-6 stage 1 fan disk envelopes at various stages of manufacture.*

warranty claim by GEAE for defective material and no record of any credit for GEAE processed by ALCOA or TIMET.

Before disk "A" was shipped to CONAM, a manufacturing process record, called a Dispatch Order (DO), indicated that a disk S/N MPO 00385 (disk "B") was machined into a rectilinear machined forging shape on September 13, 1971, and that this disk passed immersion ultrasonic and macroetch inspections on September 29, and 31, 1971.

As indicated on the DO, the remaining operations to complete processing of disk "B" for shipment to the engine assembly line included shot peening, grit blasting of the dovetail slots, metal spray of the dovetail slots, and final inspection of these operations. This work was completed on December 11, 1971. From that point, records show that disk "B" was sent to GEAE Production Assembly, where it was installed in CF6-6 engine S/N 451-251. This engine was shipped to Douglas Aircraft Company on January 22, 1972, for installation on a new DC-10-10 airplane. To reiterate, according to GEAE records, disk "A" was at CONAM from January 7 to January 31, 1972, during which time disk "B" was installed in a new engine and shipped to a customer.

The calendar history of the GEAE manufacturing activity for the eight forgings reported by ALCOA as comprising heat K8283 is shown in tabular summary. (See figure 21). Although ALCOA records indicate that a forging S/N AJV 00381 was produced from TIMET heat K8283, no record of this forging or disk could be found at GEAE.

As previously discussed, GEAE records showed two entries on a "critical rotating parts list" for a S/N MPO 00385 stage 1 fan disk. One of the entries agreed with ALCOA records, listing the disk as being from heat K8283. The other S/N MPO 00385 entry listed the disk as being from heat 704233. Heat 704233 is a valid heat number determined to have been used by Reactive Metals Inc. (RMI) for a heat of Ti-6Al-4V. Further research of GEAE records showed no other entry of a heat number 704233 for other titanium parts manufactured at GEAE, spanning the entire period from 1969 to 1990.

ALCOA records indicated that material from RMI heat number 704233 was in inventory at ALCOA at the same time that fan disk forgings from TIMET heat K8283 were being processed. ALCOA's Stock Inventory Record (Titanium) indicated that heat 704233 was received at ALCOA on November 20, 1970, and that this Ti-6Al-4V RMI material was in the form of a 16-inch diameter billet, certified to GEAE material specification for fan disk material. However, ALCOA's records also indicate that RMI heat 702233 was first cut in 1972, several years after forging the disk blanks from TIMET heat K8283. The records indicate that three of the pieces cut from 704233 weighed about 700 pounds, a weight consistent with that needed to produce a CF6-6 engine stage 1 fan disk. The records further indicate that all forgings made from heat 704233 were accounted for and were forgings for airframe parts.

Records for RMI heat 704233 indicate that this heat was produced from a double melting procedure that used argon gas instead of a vacuum inside the melting chamber during the second melt.

# HISTORY OF HEAT # TIMET - K8283

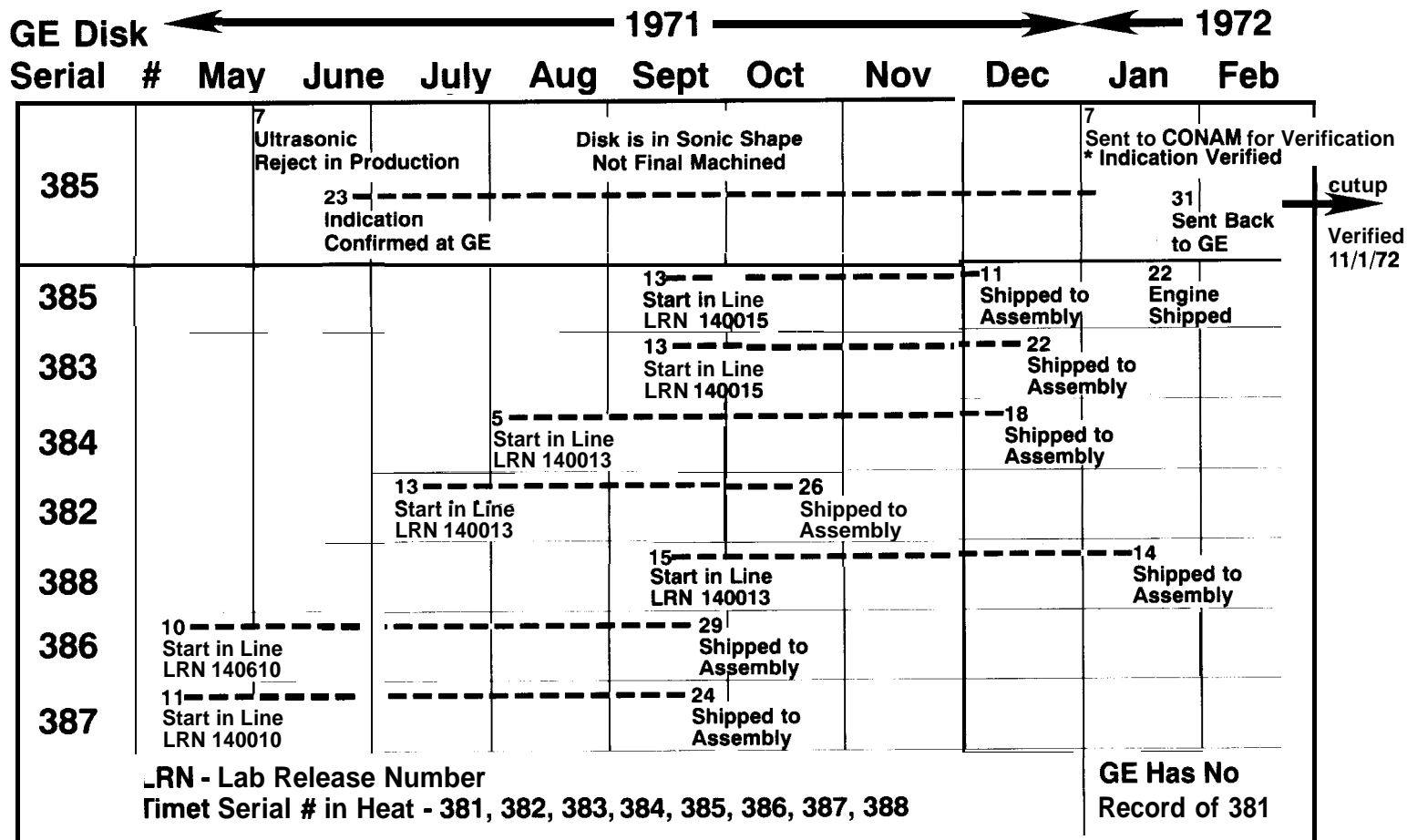

Figure 21. -- Calendar history of manufacturing activity of heat K8283 prepared by GEAE.



In 1970, separation of a fan disk produced by another manufacturer occurred during takeoff on a DC-8 aircraft in Rome, Italy. This fan disk was manufactured from RMI argon remelted material, the same procedure used for heat 704233. The cause of the separation was traced to a Type II segregate present in the fan disk material. The separated fan disk had been manufactured from the top position of the billet. The investigation findings at the time indicated that the argon remelting process had created a tendency for Type II segregation anomalies to occur in the top portion of the billet.

Based on these findings, the FAA and the US Air Force mandated that for future critical rotating parts, the use of double-vacuum-melted material would be the minimum standard. Stocks of material initially melted under vacuum and remelted under argon could be utilized, provided that the top 7 percent of the top billet of such material was discarded or used for nonrotor applications.

GEAE complied with the November and December 1970 FAA instructions, immediately required double-vacuum-melted material as the minimum standard, and notified suppliers of this requirement. The fan disk from the UAL accident airplane was produced after the requirement became effective.

During the investigation, the Safety Board was advised by TIMET that the material contained in the accident disk may not have been produced at the TIMET facility. TIMET contended that certain trace elements, which should have been present in any material of TIMET manufacture, were not detected in sufficient quantity to identify TIMET as the producer. As a result, under the direction of the Safety Board, four independent chemical analyses were undertaken by TIMET, GEAE, ALCOA and RMI. All four companies forwarded submissions on this subject to the Safety Board. TIMET's submission stated that some of the disks (including the separated disk S/N MPO 00385) have sulfur and phosphorous levels below the range expected for titanium material produced by TIMET during the 1969-1971 timeframe. TIMET'S and GEAE'S submissions stated that disks S/N's MPO 00382, MPO 00385, MPO 00386, and MPO 00388 were not produced by TIMET. However, RMI's submission stated that all seven disks could be from the same heat and that the variations in chemical elements could be the result of normal variability of chemical element concentrations within a heat. Further, RMI stated that heat 704233 was made from only 100 percent RMI titanium sponge and master alloys with no scrap added and therefore that this heat could not have been used to produce the separated disk or other disks that contained phosphosulfide inclusions. ALCOA's analysis stated that the disks appear to separate into two groups based on the variations in the trace chemical elements; however, ALCOA added that there is insufficient data to determine the causes of the differences.

#### 1.17.4 Inspections During Disk Manufacture

During the manufacturing process for the separated fan disk, the disk material or disk part underwent four nondestructive inspections. The purpose of these inspections was to detect the presence of anomalies, both internally and on the surface.

The first inspection was performed by TIMET in 1970. This inspection was a contact-ultrasonic inspection of the 16-inch diameter billet from heat K8283. The purpose of this inspection was to detect subsurface (internal) flaws. Currently manufactured titanium alloy billets for disk usage are subjected to an immersion-ultrasonic inspection that has a greater sensitivity to detect internal flaws.

ALCOA was not required to inspect the forgings for internal defects; however, it did perform material specification tests to verify the integrity of the forging.

GEAE performed the second inspection, an immersion-ultrasonic inspection of the disk forging after it had been machined to the rectilinear machine forged shape (RMF). In 1971, when the accident disk was processed through GEAE, the testing equipment was calibrated to a standard, with the output from the calibration maximized to 80-percent full-scale height (FSH) on the readout equipment. An additional +12 decibels (dB) of gain was then added to the output signal during the inspection, increasing the sensitivity by a factor of 4 above the standard calibration. Reject level was set at 60-percent FSH, and all signals above 30 percent were evaluated.

The immersion-ultrasonic inspection specified for currently produced disks requires a 6 dB gain for the output signal, rather than the 12 dB gain used in 1971. For most of the ultrasonic scan modes (angle of the probe) in the current inspection (taking into account their specified evaluation and rejection criteria), this change results in an average drop in sensitivity of about 50 percent. The average drop in sensitivity cannot be stated more accurately because of changes in the evaluation and rejection limits, the addition of automatic depth compensating features, and more scan modes. Further, the current inspection utilizes strip chart recorders, which do not require continuous monitoring. Thus, an indication above the evaluation or rejection limit is more likely to be perceived by the human operator during the current inspection. Since 1971, GEAE has also made improvements in the transducers that impart the sonic waves into the material, in the inspection systems that control movement of the transducers, and in the instrumentation that receives, amplifies, and displays the reflected signal.

GEAE also performed a macroetch inspection on the rectilinear machine forged shape. This inspection highlights microstructural changes or anomalies on the surface. In the early 1970's, only a nitric hydrofluoric acid mixture was used by GEAE in the macroetch procedure. The current GEAE macroetch requirement is for a two-step etching process. The first step uses a nitric hydrofluoric acid mixture identical to that used in 1971. The second step of the current two-step process involves immersion in an ammonium bifluoride solution. The second step enhances the contrast developed by the nitric hydrofluoric acid step and provides somewhat better definition of any material anomaly present on the surface.

The final nondestructive inspection performed on the accident disk before it entered service was a fluorescent penetrant inspection (FPI), accomplished by GEAE on December 9, 1971, with no anomalies found. Currently

manufactured disks also receive an FPI inspection that incorporates improvements in the inspection products and techniques that have evolved since 1971.

#### 1.17.5 Responsibility for Continuing Airworthiness

The investigation revealed that the GEAE design and service life of the CF6-6 stage 1 fan disk were based on the assumption that the titanium alloy material that passed GEAE's in-house quality assurance tests and inspections during manufacture was free of defects. GEAE did not depend on the supplier for in-depth inspections but relied on its own immersion-ultrasonic inspection, macroetch and FPI inspection to provide quality assurance during disk manufacture.

During certification, GEAE presented low-cycle fatigue analyses and calculations to the FAA indicating that a defect-free part would not initiate a fatigue crack for a predicted service life of at least 54,000 cycles. The FAA applied a 1/3 safety factor multiplier to the prediction to arrive at a safe life limit of 18,000 cycles. A number of CF6-6 disks have nearly attained the 18,000 cycles and have been retired as uneconomical to reassemble in an engine. Many of them were stored by the operators in anticipation of an FAA-approved service life extension. In fact, GEAE had submitted an application for life extension to 20,000 cycles shortly before the UA 232 accident. Historically, there had not been a reported cracking problem with a CF6-6 stage 1 fan disk.

The GEAE CF6-6 shop manual has always called for FPI of the fan disk each time it is separated from the fan module (at piece part exposure), and this requirement was incorporated in the UAL inspection program approved by the FAA. Additional field inspections of the CF6-6 stage 1 fan disks were based on service history of the fleet and were incorporated into the shop manual and GEAE service letters.

Commercial air carriers operate in the US per the Code of Federal Regulations defined in Title 14 - Aeronautics and Space, Chapter I, Subchapter G, Part 121. The basic maintenance regulations are contained in Part 121, Subpart L - Maintenance, Prevention Maintenance and Alterations. Key ingredients are trained personnel, proper instructions, and the required tooling and facilities.

FAR 121.363(a)(2) states "Each certificate holder is primarily responsible for the performance of the maintenance, preventive maintenance and alteration of its aircraft, including airframes, aircraft engines, propellers, appliances, emergency equipment, and parts thereof, in accordance with its manual and the regulations of this chapter."

FAR 121.365 defines the organization required, FAR 121.367 defines the programs required, FAR 121.369 defines the manual requirements, FAR 121.271 defines the inspection personnel, and FAR 121.373 defines a continuing analysis and surveillance program.

The requirements specify that each certificate holder shall have an inspection program manned by trained, certified "personnel located in an organization separate from the other maintenance, preventive maintenance or alteration functions." The airline maintenance manual defines "the method of performing required inspections and a designation by occupational title of personnel authorized to perform each required inspection." The manual must include "procedures, standards and limits necessary for required inspections and acceptance or rejection of the items required to be inspected and for periodic inspection and calibration of precision tools, measuring devices, and test equipment."

UAL's Maintenance Program Logical, Information Based on Reliability Analysis (LIBRA), under which the CF6-6 engines installed on the accident aircraft were maintained has features common to the primary maintenance processes, (Hard Time, On Condition, Function Verification and Condition Monitoring). The LIBRA concept is based on the theory that "an efficient maintenance program is one that schedules only those tasks necessary to meet the stated objectives," including safety of flight, as well as those tasks that "should be accomplished concurrently in the interests of economy."

Each aircraft part or system is analyzed by UAL's Maintenance Department in accordance with a decision tree. The key questions on the decision tree are:

- 1) is there a reduction in failure resistance detectability by either flightcrew monitoring or by in situ maintenance and unit testing.
- 2) does the failure mode have a direct adverse effect on operating safety,
- 3) is the function visible to the flightcrew,
- 4) is there an adverse relationship between part or system age and reliability.

Each part or system is then assigned one or more types of primary maintenance processes.

UAL's CF6-6 engine maintenance program specified condition-monitoring maintenance modified by hard-time limits, and on-condition tasks modified by soft-time limits. The stage 1 fan disk had an on-condition soft-time (nonmandatory) inspection limit per the GEAE shop manual and an inspection threshold of 14,000 hours as a UAL limit. Thus, the engine theoretically could have been installed in a UAL airplane and, if there were no conditions that required the engine's removal and module disassembly, the stage 1 fan disk would not have been inspected until it reached the inspection threshold limit. Thereafter, theoretically if there were no on-condition removals, the engine could remain in operation until the fan disk reached the life limit. In practice, GEAE statistical data indicate that the fan module is disassembled, as a fleet average, about every 2,500 cycles.

The six inspections of the accident fan disk, including the inspection 760 cycles before the accident, were performed in accordance with UAL document 72-21-03. UAL NDT<sup>10</sup> inspection requirements included FPI of the disk and ultrasonic inspection of the dovetails. FPI requirements were found in document UAL GN-3-0-0-18, Process 58.

A review and comparison of GEAE's Standard Practices Manual (SPM) and UAL FPI Procedures Operation sheets were performed. Both documents specify that the CF6-6 fan disk receive a steam cleaning per UAL GN-4-0-30-20 Process 2H and an alkaline cleaning for titanium per GN-4-0-3-20 Process 2B. After cleaning, the remaining molydag (molybdenum disulphide) coating may be removed as required, using glass bead blast per GN-4-0-0-6 Process E-25.

UAL used Magnaflux products for FPI Process 58. These products consisted of:

Penetrant ZL30A  
 Remover ZR10A at nominal 20 percent concentration  
 Dry developer ZP4A  
 Nonaqueous wet developer (NAWD) ZP9

These products were all approved per the Standard Practice Manual 70-32-02 for Class G FPI. The UAL procedure GN-3-0-0-18 Process 58 allowed ZL37 penetrant as an alternate. ZL37 was one of the newer approved Magnaflux penetrants that replaced ZL30A; the latter is no longer manufactured by Magnaflux. Airlines were permitted to use existing supplies of ZL30A penetrant. The application of the penetrant remover and developer per UAL procedure involved typical industry practice. The UAL procedure allowed for the use of the self-filtered 125-watt ultraviolet lamps for inspection.

The UAL procedure warned inspectors that titanium parts resist the capillary action of the penetrant and that "complete penetrant coverage is required for these materials." Also, the procedure cautioned not to overwash the parts or the penetrant might be flushed out of true indications. The disk bore is mentioned as a critical area for inspection, along with other areas.

At UAL's maintenance facility, a disk was hung from a steel wire covered with a sheath. This hanging device was routed through the bore. The suspension device obscures both the application of penetrant and developer which is applied with a hand-held wand. Inspection personnel had to pause during application to lift up sharply (jerk) on the disk to rotate it. With disk rotation, the previously masked area was exposed and the FPI material was applied to the area with the wand.

---

<sup>10</sup> NDT, Nondestructive testing refers to inspection methods, such as fluorescent penetrant, magnetic particle, radiographic, ultrasonic, and eddy current inspections that do not damage or significantly alter the component during the inspections.

The Safety Board staff visited another operator's disk inspection facility and found a different suspension system in use. The disk was mounted through the bore on a teflon spindle with a small retaining lip. The spindle also precluded full coverage of part of the disk by the penetrant and developer. This operator used automated application, but rotation by hand was still required to get coverage of the masked area of the bore.

#### 1. 17. 6 Certification Requirements

##### 1. 17. 6. 1 Certification Requirements - Aircraft

Certification requirements for the DC-10-10 were specified in the 14 CFR; Part 25 Airworthiness Standards: Transport Category Airplanes dated February 1, 1965, with Amendments 1 through 22 and Special Condition 25-18-WE-7, dated January 7, 1970. Part 25, paragraph 25.903(d) governed turbine powerplant installations. This paragraph stated that:

*"Unless the engine type certification specifies that the engine rotor cases can contain damage resulting from rotor blade failure, turbine engine powerplant installations must have a protection means so that rotor blade failure in any engine will not affect the operation of remaining engines or jeopardize continued safety. In addition, design precautions must be taken to minimize the probability of jeopardizing safety if an engine turbine rotor fails unless:*

*(1) The engine type certificate specifies that the turbine rotor can withstand damage-inducing factors (such as those that might result from abnormal rotor speed, temperature or vibration); and (2) The powerplant systems associated with engine devices, systems and instrumentation give reasonable assurance that those engine operating limitations that adversely affect turbine rotor structural integrity will not be exceeded."*

Special Condition 25-18-WE-7 stated that, "In lieu of the requirement of (paragraph) 25.903(d)(1), the airplane must incorporate design features to minimize hazardous damage to the airplane in the event of an engine rotor failure or of a fire which burns through the engine case as a result of an internal engine failure."

Special Condition 25-18-WE-7 was imposed by the FAA as part of certification of the DC-10-10 because FAR 25.903(d) was in the process of being revised and the applicable airworthiness requirement did not contain adequate or appropriate safety standards for the DC-10. In response to the special condition requirements, on July 1, 1970, Douglas responded by supplying information to the FAA that indicated the powerplants and associated systems were isolated and arranged so that the probability of the failure of any one engine or system adversely affecting the operations of the other engines or systems was "extremely remote." The response also noted that hydraulic system design considerations demonstrated compliance with the

special conditions. The FAA responded on July 17, 1970, that the review of Douglas' compliance was complete and that the requirements of the applicable regulations and special conditions were satisfied. Amendment 23 was adopted after DC-10 certification and included the revised FAR 25.903(d). FAR 25.903(d)(1) mandated "incorporation of design features to minimize the hazards to the airplane in the event of a rotor (disk) failure."

FAA Order No. 8110.11 dated November 19, 1975 entitled "Design Considerations for Minimizing Damage Caused by Uncontained Aircraft Turbine Engine Rotor Failures" was distributed internally to various FAA offices.

Specific FAA-prepared advisory methods for compliance with 25.903(d) were not published until March 3, 1988, following a Safety Board recommendation on uncontained rotor separation events. Advisory Circular (AC) 20-128 entitled "Design Considerations for Minimizing Hazards Caused by Uncontained Turbine Engine and Auxiliary Power Unit Rotor and Fan Blade Failure" set forth suggested methods for compliance with the FAR. In this AC, the FAA defines potential fragment spread angles that should be considered in the design of the aircraft to minimize the hazards associated with uncontained rotor failures. Predicted piece size and energy levels are discussed. Further, this AC proposed that critical components, such as critical control systems and hydraulic systems, be located outside the area of debris impact, as determined by the spread angle and fragment energy levels. If this is not possible, shields or deflectors should be considered to minimize the hazard of the uncontained debris.

FAA Order 8110.11 contained much of the same information as contained in AC 20-128, including fragment spread angles and the suggested use of shields or deflectors. Neither FAA Order 8110.11 nor AC 20-128 were effective at the time of certification of the DC-10-10.

#### 1.17.6.2 Certification Requirements - Engine

The containment requirements for compressor and turbine rotor blades and turbine rotors were specified in the US Code of Federal Regulations, Title 14 Part 33-Airworthiness Standards; Aircraft Engines, dated February 1, 1965. No special conditions were imposed with respect to containment for the CF6-6 engine.

Rotor blade failure was addressed in paragraph 33.19, "Durability," and stated: "Engine design and construction must minimize the development of an unsafe condition of the engine between overhaul periods. The design of the compressor and turbine rotor cases must provide for the containment of damage from rotor blade failure.

To supplement this requirement, FAA Advisory Circular 33-1A, paragraph 10 and 11, provided guidelines and acceptable means for testing to demonstrate substantiation of the requirement, and such testing was accomplished.

Turbine rotor failure was addressed in paragraph 33.27 of FAR Title 14, Part 33, as follows: "To minimize the probability of failure of turbine rotors, (a) Turbine rotors must be demonstrated to be of enough strength to withstand damage-inducing factors, such as those that might result from abnormal rotor speeds, temperatures or vibration; and (b) The design and functioning of control devices, systems and instrumentation must give reasonable assurance that those engine operating limitations that affect turbine rotor structural integrity will not be exceeded in service."

FAA Advisory Circular 33-3 addressed guidance and acceptable means for complying with the turbine and compressor rotor requirements of FAR Part 33. Paragraph 5, Scope, stated that, for the rotors, "their design and construction must provide structural integrity of sufficient strength to withstand specified overspeeds and overtemperatures without failure unless rotor bursts are demonstrated to be contained within their respective housings.

Neither the FAR nor the AC required containment of a fractured fan disk. At the time of CF6-6 engine certification, the certification approval required containment of one released fan blade and any resultant damage.

The design and testing program for the fan rotor disk was selected to comply with the requirements of FAR 33 paragraphs 33.19, 33.27, 33.63 and 33.65. The Summary of Analysis and Testing Methods proposed to demonstrate compliance of the CF6-6 with these and all applicable requirements of FAR 33 and was submitted to the FAA for approval at the Preliminary Type Board meeting on January 22, 1969. Approval of this report was received in January 1970. During the design of the fan rotor, structural integrity analyses for durability and fatigue life were performed and component tests were conducted.

The durability of the fan disk was demonstrated by these analyses and by a fan rotor overspeed durability test per the approved program and the guidelines of FAA Advisory Circular 33-3.

#### 1.17.7 Field Inspection Programs

The GE CF6-6 Shop Manual specified a fluorescent penetrant inspection of the fan disk each time the disk is separated from the fan module for any reason. Further field inspections of the CF6-6 stage 1 fan disk were defined by the Shop Manual and by Commercial Engine Service Memorandum (CESM) Numbers 95 and 96.

CESM 95, issued in November 1987, described a hand-held ultrasonic inspection of the fan disk dovetail posts to be performed at every engine shop visit. It was also incorporated into the GE CF6-6 Shop Manual in November 1987. This inspection was introduced to the CF6-6 fleet after a crack was discovered in a CF6-50 fan disk dovetail post during a normal shop inspection. CESM 96 was issued in June 1988 to define a population of CF6-6 stage 1 fan disks for accelerated inspection to assist in the investigation of fan disk dovetail post cracking. The population was selected for investigative purposes only and was not a suspect population. As of



June 1990, no cracks had been discovered on the CF6-6 fan disks inspected by this method.

CF6-6 CESM No. 98 was issued as a result of this accident on August 25, 1989. It introduced an immersion-ultrasonic procedure for the complete CF6-6 fan disk. Shortly after CESM 98 was issued, a contact-ultrasonic inspection method was developed for stage 1 fan disks installed in engines or fan modules and was approved by GEAE for field use. Working with the FAA and CF6-6 airline operators, an inspection program, including time compliance requirements, was established for prioritized categories of CF6-6 fan disks. CF6-6 Service Bulletin 72-947 introduced the program to the operators.

GEAE CF6-6 Service Bulletin 72-947 was issued on September 15, 1989. The Service Bulletin recommended hand-held contact-ultrasonic inspection by a specified date, of all CF6-6 stage 1 fan disks affected by the Service Bulletin, depending on the category. It also recommended that all affected CF6-6 fan disks be immersion-ultrasonic inspected by a specified date for each category. The ultrasonic inspections recommended by SB 72-947 were in addition to the inspection requirements defined by the CF6-6 Shop Manual and CESM's No. 95 and No. 96.

CF6-6 SB 72-947 defines inspections for three prioritized categories of fan disks as follows:

Category I. -- (six sister disks) Fan disks removed from service and submitted to GEAE for evaluation by September 15, 1989. ALCOA records state that these fan disks were produced from the same billet of material as fan disk S/N MPO 00385 in the accident aircraft 451-243.

Category II. -- (total 52) Fan disks were inspected by either contact or immersion-ultrasonic inspection methods by November 21, 1989. These fan disks were limited to one contact-ultrasonic inspection and then immersion-ultrasonic inspection, or were to be removed from service by April 1, 1990. Category II disks include all disks believed to have been manufactured from the same raw materials feedstock as those used to manufacture the billet used for disk S/N MPO 00385 and the Category I disks.

Category III. -- (total 213) Fan disks were inspected by either contact or immersion-ultrasonic inspection methods by February 4, 1990. Contact-ultrasonic inspection on installed engines is required at intervals not to exceed 500 flight cycles or until the fan disk is immersion-ultrasonic inspected. These fan disks are to be immersion-ultrasonic inspected or removed from service by December 31, 1990. Category III disks include all disks believed to have been manufactured by the same process as S/N MPO 00385 (double-vacuum melt process).

The FAA issued Airworthiness Directive (AD) No. 89-20-01 as a final rule on September 21, 1989. The compliance requirements for the AD are the same as CF6-6 Service Bulletin 72-947.

All 37 Category II disks still in service were either contact or immersion-ultrasonic inspected by November 21, 1989. All Category II stage 1 fan disks inspected passed the inspection requirements.

All Category III disks were inspected by February 4, 1990, using one of the two inspection methods. Four Category III disks were returned to GE-Evendale for further inspection and evaluation; verifiable anomalies were discovered in two of the disks.

GEAE has undertaken a replacement program for all fan disks identified by CF6-6 SB 72-947 and AD 89-20-01 as Category I, II, and III. The program is administered by the GEAE Manager of Customer Service. Replacement disks were immediately made available for the Category I disks that were recalled. Category II and III disks were more numerous and were more difficult to replace. As newly manufactured spares become available in the GEAE inventory, the spares are being exchanged for disks that were removed from engines that were disassembled for either AD compliance inspections or other maintenance activity. GEAE has stated that it intends to remove from service all Category II and III disks prior to accumulation of 1,500 cycles after the immersion-ultrasonic inspection.

The Safety Board was informed that the replacement program was undertaken for commercial reasons but also because of a limitation in the immersion-ultrasonic inspection process. GEAE determined that the detectable defect size in the most critical area (bore forward corner) is a 0.1-inch radius crack. This results in a predicted residual life by GEAE calculations of 1,500 cycles. That is, a crack less than the detectable size of 0.1-inch would not propagate to failure in 1,500 cycles.

GEAE also released SB 72-962, dated July 2, 1990, which directed contact and immersion inspections of all disks forged by ALCOA. The inspections are to be conducted in a manner similar to those mandated by CF6-6 Service Bulletin 72-947 for Category I, II, and III disks--contact ultrasonic interval, not to exceed 500 cycles until a once-through-the-fleet immersion-ultrasonic inspected can be accomplished. GEAE informally stated that this inspection was initiated to verify the quality of any ALCOA disks that may have been affected by recordkeeping anomalies during manufacture.

#### 1.17.8 Hydraulic System Enhancement

On September 15, 1989, Douglas Aircraft Company announced development of design enhancements to the DC-10's hydraulic system that would preserve adequate flight control if a catastrophic in-flight event in the empennage of the airplane damages all three hydraulic systems. The enhancements consist of three separate installations: (1) an electrically operated shutoff valve in the supply line and a check valve in the return line of the No. 3 hydraulic system, (2) a sensor switch in the No. 3

hydraulic reservoir, and (3) an annunciator light in the cockpit to alert the crew to the activation of the shutoff valve.

The shutoff valve is located in the empennage forward of the horizontal stabilizer. Normally open, the valve will close automatically if the sensor switch detects hydraulic fluid dropping below a preset level in the No. 3 reservoir. The switch will also illuminate the alert light in the cockpit. If severe damage results in a breach of the No. 3 hydraulic system anywhere in the aircraft, the shutoff valve will stop fluid flow through the No. 3 hydraulic system routed through the tail. The hydraulic system enhancement is intended to provide the crew with longitudinal control by stabilizer trim input at one-half rate and lateral control through right inboard, right outboard, and left inboard aileron deflection, and with slats (but no flaps) in the event that an aircraft sustains damage similar to the damage sustained by flight 232. In addition, fluid for operation of the spoiler panels, brakes, nose wheel steering, landing gear, and lower rudder is preserved. The enhancement was mandated by FAA AD 90-13-07 effective July 20, 1990. The AD requires incorporation of the hydraulic system enhancement in all DC-10 airplanes on or before July 20, 1991.

In addition to the previously discussed shutoff valve system, Douglas also offered a system that incorporated flow-limiting fuses in the No. 3 hydraulic system. Service bulletins were issued by Douglas to cover the installation of either system. AD-90-13-07 required that CF6-6-equipped DC-10 airplanes (DC-10-10 and DC-10-10F) have either the shutoff valve or flow-limiting fuses installed within 6 months of the AD issue date. All other models of the DC-10 were required to be modified with the shutoff valve within 12 months. The AD also required that if flow-limiting fuses were installed, the airplane must also have the shutoff valve installed within 12 months. The operators had the option of leaving the fuses in the system if they had been installed.

Douglas has incorporated the enhanced hydraulic system in the MD-11. All MD-11 airplanes will be manufactured with the shutoff valve system installed.

#### 1.17.9 Historical Review

The investigation included a review of NTSB Aircraft Accident Reports 73-2, 79-17, 82-3 and relevant cases of loss of hydraulic flight controls in wide-body transport airplanes:

July 30, 1971  
San Francisco, CA

A Boeing 747 departed on a limited-length runway with incorrect takeoff reference speeds and struck an approach lighting structure, disabling 3 of the 4 hydraulic systems for flight controls. The airplane landed safely on the remaining system.

December 8, 1985  
Mt. Ogura, Japan

An improper aft pressure bulkhead structural repair on a Boeing 747 resulted in an explosive decompression that caused damage to all four hydraulic systems available for flight control. The flightcrew attempted to control the airplane with differential power. The airplane crashed, fatally injuring more than 500 passengers.

September 22, 1981  
Colts Neck, NJ

Bearing failure within the No. 2 tail-mounted engine on an L-1011 allowed the fan assembly to escape, disabling three of the four hydraulic systems available for flight control. The airplane landed safely on the remaining system.

The investigation also included a review of incident/accident records for uncontained engine failures and damage as a result of released rotating parts. NTSB Special Study, "Turbine Engine Rotor Disk Failures, NTSB-AAS-74-4" formed a basis for the review. Two FAA-sponsored industry-published statistical reports were included. They are SAE Report AIR 1537, events through 1975, and SAE Report AIR 4003, events 1976 through 1983. The review considered only commercial transport aircraft engine operating experience. The information on non-containment events was derived primarily from engine manufacturers and operators data since they have the most comprehensive records and knowledge of such events. The FAA Technical Center also produces an Annual Statistical Report of Aircraft Gas Turbine Engine Rotor Failures in U. S. Commercial Aviation, derived from data reported through the Service Difficulty Report (SDR) system. This data includes only events reported by U. S. operators, and therefore does not reflect the total engine fleet experience. Presently, there is no central repository or reporting and collecting program for acquiring and recording such data.

For the 1976-1983 period, 203 non-containment events were identified as relevant involving four transport aircraft engine types: turboprop, turbojet, low bypass ratio turbofan and high bypass ratio turbofan. Of these, five involved fan disks or disk fragments, two of which resulted in airframe damage categorized as significant or severe. There were 52 total disk failures in the 201 events. Of these, 15, or 29 percent, resulted in significant or severe aircraft damage. Of all noncontained events, 12.3 percent resulted in significant or severe aircraft damage.

For the period 1962 to 1975, high bypass ratio engine hours of operation were 5 percent of the total reported. For the period 1976-1983 they represent 23 percent of the total operating hours reported. The non-containment rate per million operating hours in the 1976-1983 period is about 2.5 times that of low bypass ratio engines, and if fan-blade-only events are excluded, the rate is 1.3 times the low bypass ratio engine rate. FAA-sponsored work will soon be undertaken by SAE on a third report, events 1984 through 1989. Selected cases are cited below.

|                                        |                      |                                                                                                                                                                                                                          |
|----------------------------------------|----------------------|--------------------------------------------------------------------------------------------------------------------------------------------------------------------------------------------------------------------------|
| April 19, 1970<br>Rome, Italy          | DC-8<br>JT-3D        | A fan disk ruptured on takeoff and the takeoff was refused. The aircraft was destroyed by fire. A hard alpha inclusion was discovered in the titanium engine fan disk (argon cap melt).                                  |
| May 2, 1972<br>Tucson, AZ              | DC-10<br>CF-6-6, #2  | The low-pressure turbine assembly separated from the engine and fell to the ground.                                                                                                                                      |
| December 28, 1972<br>Atlantic City, NJ | L-1011<br>RB211, #3  | The fan disk ruptured at 335 cycles due to an inappropriate titanium alloy selection.                                                                                                                                    |
| January 10, 1973<br>Grand Junction, CO | L-1011<br>RB211, #1  | The fan disk ruptured at 274 cycles due to an inappropriate titanium alloy selection.                                                                                                                                    |
| November 3, 1973<br>Albuquerque, NM    | DC-10<br>CF-6-6      | Part of the fan assembly disintegrated during an overspeed and parts struck a cabin window. A passenger was ejected from the cabin during a subsequent decompression. The cause of the fan overspeed was not determined. |
| May 25, 1981<br>Jamaica, NY            | L-1011<br>RB211, #3  | The stage 1 fan assembly escaped during climb because of a thrust-bearing failure.                                                                                                                                       |
| September 22, 1981<br>Colts Neck, NJ   | L-1011<br>RB-211, #2 | Event similar to that described above.                                                                                                                                                                                   |
| March 16, 1979<br>Okinawa, R. I.       | DC-10<br>CF6-50, #3  | The stage 3 disk of the high-pressure compressor failed on takeoff. A hard alpha inclusion was discovered.                                                                                                               |

|                                       |                     |                                                                                                                                                                                                                       |
|---------------------------------------|---------------------|-----------------------------------------------------------------------------------------------------------------------------------------------------------------------------------------------------------------------|
| September 22, 1981<br>Miami, FL       | DC-10<br>CF6-50, #3 | The low-pressure turbine disk ruptured because of an object that was left in the engine during assembly after maintenance.                                                                                            |
| March 17, 1982<br>Sanaa, N. Yemen     | A300B<br>CF6-50, #2 | The high-pressure turbine stage 11 disk ruptured from low-cycle fatigue around an embossment. The airplane was destroyed by fire following an aborted takeoff.                                                        |
| June 25, 1983<br>Manila, R. P.        | 8747<br>CF6-50, #4  | The high-pressure compressor stage 9 disk ruptured during climb. Low-cycle fatigue from a hard alpha inclusion was the cause. Debris punctured the stabilizer.                                                        |
| July 5, 1983<br>Chicago, IL           | DC-8<br>CFM56, #1   | Stage 1 high-pressure compressor disk separated during takeoff. The disk had 256 cycles since new. A hard alpha inclusion was discovered in the disk fracture area, which was manufactured from triple melt material. |
| January 19, 1985<br>Brazaville, Congo | 8747<br>CF6-50, #4  | The high-pressure turbine stage 1 disk ruptured in cruise due to loss of cooling air. A fuel tank was punctured.                                                                                                      |
| April 6, 1985<br>Dakar, Senegal       | DC-10<br>CF6-50, #2 | The high-pressure compressor stage 9 disk ruptured during climb. Fatigue was indicated on one recovered piece. The evidence of the fatigue source has not been located.                                               |

## 1. 17. 10 Airplane Flight Characteristics with Immovable Control Surfaces

### 1. 17. 10. 1 General Characteristics

Steady cruise level flight is attained when the forces acting on the airplane are in a state of equilibrium; that is, thrust equals drag and the airplane's weight is balanced by the lift forces produced by the airplane's wing and horizontal stabilizer. Since the lift forces produced by the wing and stabilizer and the airplane's drag vary with airspeed, the equilibrium condition is unique for a particular combination of weight, thrust, and airspeed. The airspeed at which the lift and weight forces are

balanced is in turn dependent on the angle between the relative wind and the chord line of the wing and stabilizer aerodynamic surfaces (angle of attack).

The DC-10 airplane is trimmed for the desired steady flight condition by moving the horizontal stabilizer (relative to the wing) to the position at which the normal forces are balanced without the need for the pilot or autopilot to hold constant forces on the airplanes' flight controls. Transient changes from the steady cruise condition are achieved by manipulating the controls to move the airplane's elevator, ailerons/spoilers, and rudder. The deflection of the elevator momentarily changes the lift produced by the horizontal stabilizer to cause a change in the airplane's attitude, angle of attack, and airspeed. When the deflection is removed from the elevator, the airplane will return to its original trim airspeed so that the lift and weight forces will again be balanced.

In routine flight, the pilot will change both thrust and elevator or horizontal stabilizer trim position to attain a new steady flight path; that is, to change airspeed and/or rate of climb or descent. An inability to reposition the horizontal stabilizer or move the elevator severely restricts the pilot's control over such flightpath changes by eliminating the essential means of changing the normal force balance. Under such conditions, the airplane will continuously seek the airspeed and flightpath at which the forces balance for the existing stabilizer trim position and the existing thrust level. This motion is called the phugoid.

A small change in power would typically result in a slight change in speed followed by the appropriate climb or descent and a return to approximately the same trim speed. For UAL 232, the trim speed was set by the airplane configuration and the damage resulting from engine failure and could not be reduced for landing as is normally the case.

Stimuli, such as gusts or power changes, may initiate the airplane phugoid. The phugoid produces a long period of pitch oscillation and may produce speed variations about the trim speed. If the speed varies from the trim speed, the airplane will change pitch and either climb or descend to recover to the trim speed. For example, if the speed falls below the trim speed while the airplane is in level flight, the lift produced by the wing is not sufficient to maintain altitude. The airplane will start to descend and pick up speed. Normally, the airspeed will increase beyond the trim speed and the airplane lift will become greater than required, resulting in an increase in vertical velocity and subsequent climb. During the climb, the airspeed will fall toward the trim speed. The time to complete one oscillation is called the period of the phugoid and may be as long as several minutes on some airplanes. The period of the phugoid for typical large jet transports is about 1 minute. When elevator control is present, the phugoid is easily damped and is not noticeable to the pilot.

In a situation such as UAL 232, the elevator and trim positions were constant; therefore the trim speed was set and direct control over the phugoid was not available. Variations in net power produced climbs or descents as expected. The resulting phugoid led to variations about the trim speed, as well as long-term oscillations in pitch attitude and vertical

velocity. The phugoid could be damped with properly timed small changes in thrust.

Lateral airplane control is normally achieved by using the ailerons to produce a roll angle that will result in a turn or change in the direction of flight. Since the ailerons were inoperative during the descent of UAL 232, lateral control was maintained by using differential thrust on the airplane. Differential thrust produces a yawing moment and a yaw angle where the airplane is pointed in a direction slightly left or right of the flight path. Because of the wing sweep and dihedral, a yaw angle produces a rolling moment and a roll angle. The roll angle produces the turn to a new heading.

For a landing, the elevator and ailerons may produce the required maneuvers in several seconds which allows for a precise approach to touchdown. For UAL 232, pilot-induced thrust variations were required to control the phugoid and the asymmetric rolling moments attributed to airframe damage, in addition to the maneuvers required for landing. The required maneuvers could be implemented, via thrust variations, with a delay of as much as 20 to 40 seconds. Thus, any thrust changes required for landing would have to be anticipated at least 20 to 40 seconds prior to touchdown, and any required changes within 20 to 40 seconds of landing could not be fully implemented.

#### 1. 17. 10. 2 Flight Simulator Studies

As a result of the accident, the Safety Board directed a simulator reenactment of the events leading to the crash. The purpose of this effort was to replicate the accident airplane dynamics to determine if DC-10 flightcrews could be taught to control the airplane and land safely with no hydraulic power available to actuate the flight controls. The simulator exercise was based only on the situation that existed in the Sioux City accident--the failure of the No. 2 (center) engine and the loss of fluid for all three hydraulic systems.

The DC-10 simulator used in the study was programmed with the aerodynamic characteristics of the accident airplane that were validated by comparison with the actual flight recorder data. DC-10 rated pilots, consisting of line captains, training clerk airmen, and production test pilots were then asked to fly the accident airplane profile. Their comments, observations, and performance were recorded and analyzed. The only means of control for the flightcrew was from the operating wing engines. The application of asymmetric power to the wing engines changed the roll attitude, hence the heading. Increasing and decreasing power had a limited effect on the pitch attitude. The airplane tended to oscillate about the center of gravity (CG) in the pitch axis. It was not possible to control the pitch oscillations with any measure of precision. Moreover, because airspeed is primarily determined by pitch trim configuration, there was no direct control of airspeed. Consequently, landing at a predetermined point and airspeed on a runway was a highly random event.



Overall, the results of this study showed that such a maneuver involved many unknown variables and was not trainable, and the degree of controllability during the approach and landing rendered a simulator training exercise virtually impossible. However, the results of these simulator studies did provide some advice that may be helpful to flightcrews in the extremely unlikely event they are faced with a similar situation. This information has been presented to the industry by the Douglas Aircraft Company in the form of an "All DC-10 Operators Letter." In addition to discussing flight control with total hydraulic failure, the letter describes a hydraulic system enhancement mandated by an FAA Airworthiness Directive, (See appendix D).

## 1.18 Useful Investigative Techniques

### 1.18.1 Special Investigative Techniques - Photograph Image Analysis

Color photographs of the accident aircraft were taken by a resident who lived on the approach path to Sioux Gateway Airport. The photographs, taken after the engine failure, depicted the damage to the right side and empennage of the aircraft. The photograph with the sharpest image was selected for further analysis. The boundaries and locations of the holes were calculated so that the locations of the holes could be incorporated into a three-dimensional scale drawing of the horizontal stabilizer. Three areas on the photograph contained four holes, which were selected for analysis: the hole on the leading edge of the right horizontal stabilizer; two holes slightly inboard and in the middle of the right horizontal stabilizer; and a hole on the right inboard elevator. The holes were defined as those areas where light could be observed penetrating areas of the stabilizer. They were transformed to the stabilizer coordinate system and input into the computer-aided design (CAD) system to generate a drawing of the horizontal stabilizer depicting the in-flight damage.

## 2. ANALYSIS

### 2.1 General

The flightcrew of UA 232 were trained and qualified in accordance with applicable Federal regulations and UAL company standards and requirements. The airplane was certificated, equipped, and operated according to applicable regulations. Meteorological conditions and navigation and communication facilities did not contribute to the accident. ATC services and controller performance were reasonable, proper, and supportive of the flightcrew and were not factors in the accident.

The Safety Board determined that the accident sequence was initiated by a catastrophic separation of the stage 1 fan disk from the No. 2 engine during cruise flight. The separation, fragmentation, and forceful discharge of uncontained stage 1 fan rotor assembly parts from the No. 2 engine led to the loss of the three hydraulic systems that powered the airplane's flight controls. The flightcrew experienced severe difficulties controlling the airplane and used differential power from the remaining two engines for partial control. The airplane subsequently crashed during an

attempted emergency landing at Sioux Gateway Airport. Upon ground contact, the airplane broke apart and portions of it were consumed by fire.

The Safety Board's analysis of this accident included an evaluation of:

- 0 the structural and metallurgical evidence to determine the initial failure origin within the engine;
- 0 the manner in which uncontained parts separated from the engine;
- 0 the failure of the hydraulic systems that power the flight control systems;
- 0 the capability of the flightcrew to control the airplane on its flightpath;
- 0 the effectiveness of the GEAE CF6-6 engine manufacturing, recordkeeping, and quality assurance programs;
- 0 the effectiveness of UAL's CF6-6 engine fan section maintenance and inspection practices;
- 0 the effectiveness of the FAA's oversight of the design, certification, manufacture, recordkeeping, and continuing airworthiness of the CF6-6 engine;
- 0 the effectiveness of nondestructive inspection (NDI) programs for the inspection of rotating engine parts;
- 0 the human factors aspects of airline maintenance NDI programs;
- 0 the design and certification of wide-bodied aircraft and jet engines to minimize damage from uncontained, rotating engine parts;
- 0 the effectiveness of the manufacturing process for rotating engine parts made of titanium;
- 0 cabin survivability issues, including child (infant) seat restraints; and,
- 0 rescue and firefighting services.

## 2.2 Accident Sequence

Photographs of the airplane taken during the approach to Sioux City by witnesses on the ground indicated **inflight** damage in the area of the No. 2 engine and tail section of the airplane. The location of parts of the No. 2 engine and empennage structure near Alta, Iowa, together with the

documentation and analysis of the No. 2 engine components and surrounding structure, led the Safety Board to conclude that the No. 2 engine stage 1 fan disk fracture and separation was the initial event that led to the liberation of engine rotating parts with sufficient energy to penetrate the airplane's structure.

Shortly after the engine failure, the crew noted that the hydraulic fluid pressure and quantity had fallen to zero in the three systems. Approximately 1 minute after the engine failure, the FDR recorded no further powered movement of the flight control surfaces. Consequently, the No. 2 engine failure precipitated severe damage that breached the three hydraulic systems, leaving the flight control systems inoperative.

Titanium alloy was found on the fracture surfaces of severed lines of hydraulic systems No. 1 and No. 3 located in the right horizontal stabilizer. Several of the major components of the engine, including the stage 1 fan blades and fan disk, were made from titanium alloy and no other components of the surrounding airframe were made from such material. These factors led the Safety Board to conclude that the systems' No. 1 and No. 3 hydraulic lines were severed by fragments released during the failure sequence of the No. 2 engine.

The loss of hydraulic system No. 2 required further analysis. The engine-driven No. 2 hydraulic pumps were attached to and received power from the No. 2 engine accessory section. This unit was mounted to the engine directly below the fan section of the engine. Portions of the No. 2 engine accessory section and associated No. 2 hydraulic system components, including hydraulic supply hoses, were found in the Alta, Iowa, area. Therefore, portions of the No. 2 hydraulic system and supply hoses mounted on, or adjacent to, the No. 2 engine accessory section were damaged and separated by the forces and disruption of the engine fan section during the engine failure. The investigation disclosed no evidence of other system anomalies that would have contributed to the hydraulic system or flight control difficulties experienced in the accident.

### 2.3 Performance of UAL 232 Flightcrew

Because of the loss of the three hydraulic systems, the flightcrew was confronted with a unique situation that left them with very limited control of the airplane. The only means available to fly the airplane was through manipulation of thrust available from the No. 1 and No. 3 engines. The primary task confronting the flightcrew was controlling the airplane on its flightpath during the long period (about 60 seconds) of the "phugoid" or pitch oscillation. This task was extremely difficult to accomplish because of the additional need to use the No. 1 and No. 3 power levers asymmetrically to maintain lateral (roll) control coupled with the need to use increases and decreases in thrust to maintain pitch control. The flightcrew found that despite their best efforts, the airplane would not maintain a stabilized flight condition.

Douglas Aircraft Company, the FAA, and UAL considered the total loss of hydraulic-powered flight controls so remote as to negate any requirement for an appropriate procedure to counter such a situation. The most comparable maneuver that the flightcrew was required to accomplish satisfactorily in a DC-10 simulator was the procedure for managing the failure of two of the three hydraulic systems; however, during this training, the remaining system was available for movement of the flight controls.

The CVR recorded the flightcrew's discussion of procedures, possible solutions, and courses of action in dealing with the loss of hydraulic system flight controls, as well as the methods of attempting an emergency landing. The captain's acceptance of the check airman to assist in the cockpit was positive and appropriate. The Safety Board views the interaction of the pilots, including the check airman, during the emergency as indicative of the value of cockpit resource management training, which has been in existence at UAL for a decade.

The loss of the normal manner of flight control, combined with an airframe vibration and the visual assessment of the damage by crewmembers, led the flightcrew to conclude that the structural integrity of the airplane was in jeopardy and that it was necessary to expedite an emergency landing. Interaction between the flightcrew and the UAL system aircraft maintenance network (SAM) did not lead to beneficial guidance. UAL flight operations attempted to ask the flightcrew to consider diverting to Lincoln, Nebraska. However, the information was sent through flight dispatch and did not reach the flightcrew in time to have altered their decision to land at the Sioux Gateway Airport.

The simulator reenactment of the events leading to the crash landing revealed that line flightcrews could not be taught to control the airplane and land safely without hydraulic power available to operate the flight controls. The results of the simulator experiments showed that a landing attempt under these conditions involves many variables that affect the extent of controllability during the approach and landing. In general, the simulator reenactments indicated that landing parameters, such as speed, touchdown point, direction, attitude, or vertical velocity could be controlled separately, but it was virtually impossible to control all parameters simultaneously.

After carefully observing the performance of a control group of DC-10-qualified pilots in the simulator, it became apparent that training for an attempted landing, comparable to that experienced by UA 232, would not help the crew in successfully handling this problem. Therefore, the Safety Board concludes that the damaged DC-10 airplane, although flyable, could not have been successfully landed on a runway with the loss of all hydraulic flight controls. The Safety Board believes that under the circumstances the UAL flightcrew performance was highly commendable and greatly exceeded reasonable expectations.

## 2.4 Analysis of Fan Disk Fracture

### 2.4.1 Separation of Fan Disk

Examination of the fracture surfaces of the fan disk disclosed that the near-radial, bore-to-rim fracture was the primary fracture. The fracture initiated from a fatigue region on the inside diameter of the bore. The remaining portions of the disk fractures were typical of overstress separations resulting from the fatigue failure.

Because of the geometry of the fan disk and the load paths within the disk, the near-radial fracture created a bending moment in the disk arm and web that overstressed the disk, leading to rupture and release of a segment. As soon as the segment of the disk was released, the remainder of the disk was immediately out of balance. Sufficient evidence in the form of witness marks<sup>11</sup> on the containment ring indicates that the segment of the disk with its blade roots still attached exited the engine around the 7:30 position. Additional evidence from the bearing housings and compressor section indicates that the remainder of the disk with attached blade roots immediately exited the engine from about the 1:00 position. Blade fragments, separately and in groups, were primarily liberated toward the right horizontal stabilizer and the aft lower fuselage area. The investigation disclosed that the liberated pieces of the engine banjo frame contained transferred titanium. However, the Safety Board could not determine which of the titanium engine parts struck the frame.

### 2.4.2 Initiation and Propagation of Fatigue Crack

Metallurgical examination showed that the fatigue crack initiated in a nitrogen-stabilized type I hard alpha defect at the inside surface of the bore. The hard alpha defect was formed during manufacture of the material and remained undetected through ultrasonic, macroetch, and FPI inspections performed during manufacture of the part.

Fracture mechanics evaluations performed by GEAE showed that at the time of the disk separation, the fatigue crack was of a magnitude that would cause fracture and resulting separation of the disk fan under normal loads. The number of major striations on the fatigue region was nearly equal to the total number of takeoff/landing cycles on the disk (15,503), indicating that the fatigue crack initiated very early in the life of the disk.

The results of the GEAE fracture mechanics analysis were also consistent with fatigue initiation on the first application of stress from a defect slightly larger than the size of the cavity found at the fatigue origin. The Safety Board concludes that the hard alpha defect area cracked with the application of stress during the disk's initial exposures to full thrust engine power conditions and that the crack grew until it entered

---

<sup>11</sup> Witness marks are areas of mechanical damage or transferred material whose shape, orientation, and composition can indicate what component created the damage.

thrust engine power conditions and that the crack grew until it entered material unaffected by the hard alpha defect. From that point, the crack followed established fracture mechanics predictions for Ti-6Al-4V alloy.

The Safety Board also attempted to determine the size of the fatigue crack at the time of UAL's FPI inspection of the disk 760 cycles prior to the accident. One possibility was that the discolored portion of the fatigue crack was created during the alkaline cleaning of the disk in preparation for the inspection. The fractographic examination of the fatigue region disclosed no topographic reason for the discoloration. In addition, the Safety Board is aware of no operational environment or conditions that would cause such discoloration. For these reasons, the Safety Board concludes that the discoloration on the surface of the fatigue crack was created during some step in the FPI process performed by UAL 760 cycles prior to the accident, and that the discolored area marks the size of the crack at the time of this inspection. The actual surface length of the discolored area is 0.476 inch.

The GEAE fracture mechanics analysis also was used to estimate the size of the fatigue crack at the time of the inspection. The analysis estimated that the surface length of the crack was 0.498 inch long at the last inspection.

An independent fracture mechanics analysis performed by UAL estimated a smaller crack size at 760 cycles prior to failure. However, this analysis used material properties, surface correction factors, and a load spectrum that the Safety Board believes are unrealistic.

#### 2.4.3 Source of Hard Alpha Defect

The hard alpha defect was caused by excessive amounts of nitrogen locally situated in the material. Titanium will absorb such amounts of nitrogen only when it is in its molten state.

The vacuum-melt process has not been adequate to produce a defect-free product. Increasing the number of vacuum melts from two to three has been shown to be effective in reducing the number of defects, the source of which can be the raw material, the sponge reactor, or welded material on the electrode. However, there is always the possibility that a defect can be introduced into each melt by foreign material remaining in a furnace. Since 1971, there have been improvements in furnace cleaning requirements that are intended to reduce this problem. Tighter controls have also been placed on the raw materials for premium-grade stock (that would be made into rotating parts for aerospace uses) in an effort to ensure a higher quality product.

The current technology for quality control of titanium manufacturing has progressed to the point where critical defects are rare. Additional reductions in the number and size of defects are unlikely to occur without changing to a new production process, such as hearth melting. Major efforts associated with such a changeover are currently being evaluated to determine if hearth melting can be introduced into industrial production.

Quality assurance measures to ensure that the interior of titanium parts are defect-free are based largely on ultrasonic inspections. Such inspections have been shown to be less than 100 percent effective in detecting anomalies because detectable anomalies must be associated with cracks and voids. This accident demonstrates the difficulty of inspection. Therefore, to some extent, the engine manufacturers rely upon the billet fabrication procedures for their overall quality assurance of disk material. Although the billet producers have been constantly striving to upgrade the quality of their product, defects do occur in both double- and triple-melted material. The rupture in 1983 of a GEAE CFM-56 triple-melted stage 1 high-pressure compressor rotor disk having only 256 cycles, caused by an undetected hard alpha defect, illustrates this problem.

#### 2.4.4 Formation of Cavity

The Safety Board believes that at the time of manufacture of the disk, the cavity at the fatigue origin point was originally filled, or nearly filled, with hard alpha material, making the defect more difficult to detect through ultrasonic means at the time of GEAE's ultrasonic inspection of the rectilinear machine forging (RMF) shape during the manufacturing process. The Safety Board also believes that the cavity was most likely created during the final machining and/or shot peening processes and that the shot peening probably created the microcracking parallel to and just below the cavity surface. Moreover, the shot peening quite likely created the mechanical deformation on portions of the cavity bottom. This mechanical deformation was inconsistent with damage that could occur during the accident sequence.

The Safety Board examined and rejected other theories concerning the formation of the cavity, including the following:

- a. The cavity was originally filled with hard alpha material that fell out during or shortly after the disk separation as a result of "ringing" (severe vibrations) or damage that occurred as the disk exited the airplane. The lack of a fresh fracture appearance in portions of the cavity and the location and orientation of the microcracks beneath the cavity surface do not support this possibility.
- b. The hard alpha material in the cavity was dislodged during the life of the disk, as repeated cycles of stress caused increasingly extensive cracking in the material that originally filled the cavity. However, the orientation of the microcracks beneath the surface of the cavity is more consistent with their formation by shot peening, rather than by operating stresses.
- c. The cavity was never filled with hard alpha material but was part of a large void associated with the hard alpha defect. In this case, the microcracks and mechanical damage would still be produced by the shot peening, without significant enlargement of the size of the

cavity. However, the hard alpha defect found in fan disk S/N MPO 00388 was approximately the same size as the defect area in the separated disk, and the two defects may have arisen from similar sources. Since the defect in S/N 388 contained no large voids, it is reasonable to conclude that the defect in the accident disk did not contain a void. Also, a void the size of the cavity should have been detected by the ultrasonic inspection of the RMF shape.

Therefore, the Safety Board concludes that the cavity was created during the final machining and/or shot peening at the time of GEAE's manufacture of the disk, after GEAE's ultrasonic and macroetch manufacturing inspections. The cavity and surrounding hard alpha material provided a stress raiser from which the fatigue crack initiated.

## 2.5 Origin of Accident Fan Disk MPO 00385

GEAE maintains a computerized listing of all critical rotating engine parts by part number and serial number, together with the titanium supplier's heat number, for traceability purposes. When the data for disk part number 9010M27P10 was recalled, serial number MPO 00385 was listed twice, once with heat number K8283 and once with heat number 704233. The first listing is the TIMET heat as shown on ALCOA records, and the second is a Reactive Metals Incorporated (RMI) heat number, which appeared in GEAE records only in the critical rotating parts list. ALCOA records show that RMI heat 704233 was received at ALCOA in October 1970, and remained in inventory until first cut in March 1972, 2 months after disk MPO 00385 was shipped from GEAE in an engine. The ALCOA records indicate that none of the forgings made from heat 704233 were delivered to GEAE.

Because of the discovery of contradictory records, chemical analyses were performed on the separated disk material in an attempt to verify its technical specifications and to relate the manufactured part to its basic source material. Multiple samples were removed from the bore and from the rim of each of the seven disks that records indicate were from TIMET heat K8283. In order to ensure unbiased analyses, the samples were coded before being distributed to GEAE, ALCOA, TIMET, and RMI for analysis. Results of the chemical analyses were gathered, the sample identifications were decoded, and the results distributed among the parties. In general, the chemical analyses showed that the material complied with the composition limits set forth in the applicable GEAE materials specification.

Statistical analysis of the trace element data from the chemical analyses performed by the four companies shows significant variations in some of the trace elements between the seven disks. At least two groups of disks are suggested by these analyses, and comparisons of the mean values for several elements tend to group disks MPO 00383, MPO 00384 and MPO 00387 in one cluster and disks MPO 00382, MPO 00385, MPO 00386 and MPO 00388 in another. These statistical analyses do not identify the origin of either cluster of disks, and the Safety Board cannot determine if the seven disks came from the same heat or from different heats.



However, if these disks were not produced from the same heat, the records on a large number of GEAE disks are suspect. It also means that any AD action that is based on the serial number of a disk may fail to have its intended effect because suspect disks could remain in service. For example, the AD 89-20-01 target population includes the Category I, II, and III disks, based on serial number. Because of doubts about the records, the FAA would be unable to determine whether all disks made from the billet that produced the accident disk (Category I disks) have been removed from service. Also, the priority of inspections of Category II and III disks may be inappropriate in some cases if the records do not accurately reflect the heat information, and there may be double-vacuum melted disks identified as triple-vacuum melted disks.

During the investigation, Safety Board investigators visited the ALCOA facility, inspected all available records, and viewed the forging processes in the production area. They compared stock undergoing successive forging operations and heat treatments and the records accompanying the items. They also observed heating and blocking (striking) and final forging operations in which parts were unmarked and arranged in groups on pallets. At times, they could only be identified by the accompanying "shop traveller" paperwork, which, by necessity, was separated from the parts and pallet. Because of the nature of the industrial operations conducted, identification data could be exchanged between parts in process. However, no evidence other than the chemical variances was found to indicate that any such misidentification occurred in the case of disk MPO 00385.

ALCOA keeps bulk materials in inventory at its forging facilities in order to fill customer orders more efficiently. Inventory records indicate that during the time of the manufacture of disk MPO 00385, ALCOA had argon remelted titanium billet material in stock. Its production records indicate that this material was never manufactured into GEAE parts, nor was it shipped to the GEAE facilities. Nevertheless, a stock number from some of this material (RMI heat 704233) appears in GEAE records as a source for one of the disks identified with S/N MPO 00385. No other records exist to corroborate or resolve this anomaly. In fact, all other GEAE and ALCOA records show that MPO 00385 was fabricated from TIMET heat K8283.

On July 2, 1990, GEAE issued SB 72-962, which directed a fleet campaign to verify the quality of 119 additional CF6-6 fan disks forged by ALCOA. The Safety Board has been informed that the FAA intends to issue an AD to mandate compliance with the intent of GEAE Service Bulletin 72-962. Until such time as an AD is issued, the Safety Board remains on record as recommending that the FAA mandate compliance with the Service Bulletin.

Not all records associated with the manufacture of fan rotor disks relevant to this accident were available from GEAE. The TIMET and ALCOA records indicate that the billet and forgings were manufactured and certified in accordance with the then-current GEAE specification for titanium used in rotating parts. However, several anomalies appear in the GEAE records, which call into question the reliability or accuracy of all the disk records from the same period. For instance, there were no records found indicating receipt of the fan disk forgings by the GEAE plant.

Chronologically, the first appearance of a GEAE part number 9010M27P10 for fan disk S/N MPO 00385 was on an ultrasonic inspection log sheet dated June 7, 1971, which indicates that a disk with S/N MPO 00385 was rejected and marked, "hold for investigation." There was no dispatch order card found dated in June 1971 for this serial number. Although a stock inventory card indicated that in August 1971 a CF6-6 stage 1 fan disk in the RMF shape was located in the materials lab for ultrasonic investigation, this card did not indicate a serial number. Nevertheless, a dispatch order card from GEAE records indicates that a disk with S/N MPO 00385 entered the manufacturing process on September 3, 1971, as a forging, and it passed ultrasonic inspection on September 29, 1971. This disk had a traceable record history leading to engine S/N 451-243, the No. 2 engine in the accident airplane.

A billet map prepared by ALCOA indicates that eight disk forgings, S/N MPO 00381 through MPO 00388, were made from a TIMET-supplied billet, heat number K8283. However, there were no GEAE records of any kind for a S/N MPO 00381 disk. Instead, there were two disks having S/N MPO 00385. Serialization of the disks was initiated by the forger, in this case ALCOA, from blocks of serial numbers provided by GEAE. There was no evidence at Alcoa to indicate that the company shipped two disks having S/N MPO 00385.

Additionally, GEAE and vendor correspondence records indicate that a S/N MPO 00385 disk was tested by an outside laboratory in January 1972 and that an indication of an anomaly was confirmed ultrasonically. The indication was not in the area of the bore where the defect existed on the accident disk. The disk with the ultrasonic indication was reportedly cut up by GEAE in an attempt to identify the source of the indication; no metallurgical anomalies were found. The Safety Board concludes that the outside laboratory had possession of the disk with the ultrasonic indication (as confirmed by the outside laboratory) at the time that the disk that eventually separated was receiving its final processing through GEAE. Therefore, the Safety Board believes that the two S/N MPO 00385 disks were not switched at GEAE.

The results of the chemical analyses show that disks S/N MPO 00382 through S/N MPO 00388 could have been forged from two or more billets. However, no further records were found either at GEAE or Alcoa that could confirm the origin of the material. Only limited, uncorroborated evidence suggests that the failed disk was produced from titanium not intended for use in rotating engine parts. However, if such a situation had existed, it could have contributed to the accident.

A primary purpose for lengthy retention of manufacturing and maintenance records, in addition to the certification of materials and procedures, is traceability in the event of in-service difficulties or failures. However, the records are only as useful as the thoroughness and accuracy of the persons initiating them and the system used for auditing, handling, and storing them. It appears that in the early 1970's, much of the data entry and transferral was accomplished by hand and that GEAE did not adequately audit critical parts records for accuracy. Consequently, the Safety Board concludes that the recordkeeping portion of GEAE's quality

assurance program on the manufacture of CF6-6 fan disks in the early 1970's was deficient.

The Safety Board is concerned that adequate manufacturers' recordkeeping provisions may not currently be in effect. Consequently, the Safety Board recommends that the FAA conduct a comprehensive evaluation of manufacturing recordkeeping and audit procedures to ensure that adequate quality assurance and traceability of critical airplane parts can be accomplished at all manufacturing facilities.

#### 2.5.1 Quality Assurance During Manufacturing Process

Ultrasonic and macroetch inspections were performed during the manufacturing process in 1971. The Safety Board tried to determine whether some GEAE inspection process could have or should have detected the hard alpha defect that served as the initiation point for the fatigue crack.

In the area of the bore surface of the disk, only about 0.15 inch is removed from the rectilinear machine forging shape during machining to the final shape. Since it is known that the altered microstructure surrounding the core of the hard alpha defect in the disk bore extended at least 0.273 inch aft of the center of the cavity, and for a smaller distance forward, the altered microstructure may have extended through most or all of the material removed during final machining. However, there are two reasons why the altered microstructure may not have been detectable on the rectilinear machine forged shape.

First, the material grain flow is largely parallel to the bore surface at this location. Therefore, the material segregation area would have a distinct tendency to be elongated in the direction of the grain flow, that is, in the axial direction. Because of this tendency, the radial width of the segregation area may have been much smaller than its axial length and therefore may not have extended to the surface of the rectilinear machine forged shape.

Second, some form of altered microstructure may have been detected during the inspection of the rectilinear shape, and the microstructure may have been evaluated and found acceptable, but no record of such an inspection evaluation has been found. This possibility is plausible since most of the area outside the core of the hard alpha defect contained a microstructure that, while obviously different from the matrix microstructure, was acceptable per the material specifications.

The ultrasonic inspection that was conducted on the rectilinear shape of the separated disk by GEAE in 1971 could have detected the hard alpha area only if there had been cracking or voids associated with the defect. The defect was far enough below the rectilinear shape surface that the "noise" associated with entry of the ultrasonic beam into the part would not have affected the response from the hard alpha area. Therefore, it is possible that either the hard alpha area did not have voids or cracks associated with it at that time or the inspection was performed incorrectly or inadequately.

Information available from the titanium industry indicates that virtually all the hard alpha defects that have been detected ultrasonically are associated with relatively large voids. This information is reasonable, since the presence of large voids makes detection of the hard alpha much easier by ultrasonic inspection. However, certain hard alpha defects may not be associated with large voids. This condition was demonstrated by the hard alpha defect areas found within the web of one of the sister disks, S/N MPO 00388. Detection of defects of this type would be difficult using ultrasonic inspection methods, since the change in ultrasonic attenuation at the boundary between the parent metal and the hard alpha is neither abrupt nor large.

During the metallographic evaluation of the ultrasonically located defect in disk S/N MPO 00388, significant amounts of microcracks were found associated with areas of hard alpha. It is these cracks that led to the detection of the defect areas through ultrasonic inspections conducted after the accident. Disk S/N MPO 00388 was also ultrasonically inspected during 1971, while it was in the rectilinear shape, and no indications above the rejectable limits were reported. This fact suggests that if a proper manufacturing inspection was performed, the microcracking associated with the defects in MPO 00388 was introduced into the disk after the 1971 ultrasonic inspection of the rectilinear shape. However, the ultrasonic indications generated from the recent postaccident inspection were only at the rejectable limit, and differences in the 1971 rectilinear shape inspection and the recent inspection on the final part shape make the two inspections not identical because of both procedural inspection changes over time and the alterations by final machining.

During 1971, GEAE manufacturing specifications required the disks to be macroetched in order to inspect for material segregation and other material-related defects. The etchant used by GEAE was a mixture of hydrofluoric and nitric acids in water. The disks were etched while in the rectilinear shape. Representatives of GEAE stated that the final shape of the disk was not macroetch inspected for a variety of reasons, including concern that the etching procedure would remove too much of the surface material. GEAE's current etching practice for disks is nearly identical to the practice in 1971, with the exception that a second, contrast-enhancing step has been added to the etching procedure.

Although GEAE vendors used final shape etching on fan blades, the process was not intended to detect microstructural anomalies. The Safety Board was informed during the investigation that the final shape etching process was intended to enhance the subsequent in-process inspections.

By contrast, other major turbine engine manufacturers have used a final shape etching procedure for many years. It is called blue etch anodizing (BEA), and it is used to macroetch titanium parts, including fan blades and disks. During the investigation, the Safety Board employed the BEA procedure on the pieces of the separated disk, as well as on the sister disks (the disks reportedly from the same heat as the separated disk). A comparison between the BEA procedure and the GEAE macroetching procedure showed that they were approximately equal in their capability to detect

material segregation, such as was found on disk S/N MPO 00388. However, neither BEA nor an acid etch would detect a subsurface defect.

The UA 232 accident occurred because an undetected hard alpha inclusion on the surface of the disk caused initiation of a fatigue crack that eventually grew to a critical size, producing catastrophic separation of the disk. The initial hard alpha inclusion may not have been detectable using the 1971 or current ultrasonic inspection methods. In addition, the macroetching procedure that GEAE performed during the manufacturing process may not have been capable of detecting the flaw because the macroetch was performed on the rectilinear machine forged shape instead of on the final part shape. Based on the Safety Board's conclusion that the cavity was most likely created during the final machining and/or shot peening process, the Safety Board further concluded that the flaw would have been apparent if the part had been macroetched in its final part shape. The Safety Board addressed this issue in its safety recommendation A-90-91 issued June 18, 1990. (See section 4).

## 2.6 Operator Inspection Program and Methods

Maintenance records indicated that the stage 1 fan disk, the fan booster disk, the fan shaft, and the No. 1 bearing had been inspected in accordance with the UAL maintenance program and the GEAE CF6-6 shop manual. The records search also showed that none of the engines in which the fan disk had been installed had experienced an overspeed or bird strike. There were no items in the prior 3 months' flight records relating to the fan components.

The stage 1 fan disk records indicated that the disk had been through six detailed part inspections in its lifetime, each of which included FPI of the entire disk. All of them had been stamped and accepted by the inspectors with no crack indications observed. The last inspection was about 1 year prior to the accident. All the records examined, as well as the life history and tracking methods, appeared to be in accordance with the FAA-approved UAL maintenance program.

Based on the evaluations and contributions from GEAE, UAL, and FAA, the Safety Board believes that the GEAE predictions of crack size more closely represent actual conditions. That is, GEAE fracture mechanics predictions indicate that, at the time of the last inspection, the length of the crack was almost 1/2 inch along the bore surface.

The portion of the fatigue crack around the origin that was discolored was slightly less than 1/2-inch long along the bore surface. This size corresponds reasonably well to the size of the crack predicted by the GEAE fracture mechanics evaluation. Therefore, the Safety Board concludes that the discolored area marks the size of the crack at the time of the last inspection and that processing steps during the inspection created the discoloration.

During FPI inspection, a crack the size of the discolored region should have a high probability of detection, presuming that a proper inspection was conducted. At the time of the inspections prior to the most recent inspection in April 1988, the crack in the disk would have been much smaller. However, the GEAE fracture mechanics evaluation indicated that the surface length of the crack during several of the inspections prior to April 1988 was such that the crack would normally have been detectable by FPI. The Safety Board recognizes, however, that the unique metallurgical properties of the origin area may have altered the detectability of the crack during these inspections.

One factor that might "close" a crack and make detection more difficult is the presence of residual bulk compressive stresses. These stresses can be generated when a part is loaded so heavily that the yield stress is exceeded in local areas, resulting in permanent elongation of the metal in the stressed area. When the stress is removed, the unyielded material tries to force the yielded material to return to its original condition, resulting in a residual compressive stress on the yielded area and a residual tensile stress on the adjacent unyielded material.

Measurements on one of the sister disks revealed virtually no bulk residual stresses. Also, there is no reason to expect that the disk normally would have operated under conditions allowing stresses as high as the yield stress to be generated on the disk. Therefore, the Safety Board discounted the residual stress theory as a reason for UAL's not detecting the crack at its inspection.

UAL has asserted that it is possible for the compressive layer associated with shot peening to "close" a crack in shot peened titanium alloy, thereby preventing entry of the FPI fluid into the crack. The Safety Board is aware that shot peening or other types of mechanical work performed on the surface, if done immediately prior to inspection, may reduce or even eliminate the FPI indication. However, discussions with the FAA National Resource Specialists (for Fracture Mechanics and Metallurgy and for Nondestructive Evaluation) and other industry experts have indicated that shot peening, performed prior to cracking, has only a minimal effect on the probability of detection of a given sized flaw. In support of this contention, UAL attempted to obtain shot peened titanium engine components with large cracks that could not be detected using FPI. However, UAL personnel stated that the only components available up to the date of this report contained small cracks that, while they could be detected using eddy current inspection, were below the detectable limits of the FPI process. Further, the Safety Board possesses data indicating that FPI has long been a proven inspection method for detecting cracks on other shot peened parts. Therefore, the Safety Board concludes that the presence of shot peening on the fan disk should not have prevented the detection of the nearly 1/2-inch long crack in the disk bore at the last inspection.

Analytical procedures performed on the fracture face of the segment of the rotor disk and water washings from this surface showed the presence of di and triphenyl phosphates, compounds present in FPI fluid similar to that used to inspect the disk prior to the failure. This unique combination of

*chemicals shows that the crack existed at the time of this inspection and that the crack was sufficiently open so that the FPI fluid entered the crack. Based on this finding and the conclusion from metallurgical analysis that the crack was approximately 0.5 inch long on the surface of the bore of the rotor disk at the time of last inspection, the Safety Board concludes that the crack was detectable at the time of last inspection with FPI fluid. However, the crack was not detected and consequently the rotor disk was considered to be free of flaws and was accepted as a serviceable part.*

*A review of the inspection process suggests several explanations for the inspector's failure to detect the crack. It is possible that the inspector did not adequately prepare the part for inspection or that he did not rotate the disk, as it was suspended by a cable, to enable both proper preparation and subsequent viewing of all portions of the disk bore, particularly the area hidden by the suspension cable/hose. It is also possible that loose developer powder, which could have dropped from the suspension cable, obscured the crack sufficiently to prevent its recognition as a flaw. Finally, inspection experience indicates that certain areas of CF-6 disks, because of their geometry, frequently show large FPI indications and that other areas rarely do so. One such area of frequent indications is around the perimeter of the disk near the dovetail posts. By contrast, the central bore area apparently has rarely produced FPI indications. Thus, it is possible that the inspector did not consider the bore area a critical area for inspection, as stated in UAL's inspection directives, and that he gave the bore area only cursory attention, thereby reducing the likelihood that a crack would be detected. Any of these possibilities, or some combination of them, could have contributed to nondetection of the crack in this case.*

*The UAL maintenance program is comprehensive and based on industry standards. The company's inspection requirements for the CF6-6 stage 1 fan disk are generally consistent with other airline practices and comply with Federal regulations. Further, UAL's procedures for selecting, training, and qualifying NDI personnel are also consistent with industry practices. However, it is clear that the adequacy of the inspections is dependent upon the performance of the inspector. That is, there are human factors associated with NDI processes that can significantly degrade inspector performance. Specifically, NDI inspectors generally work independently and receive very little supervision. Moreover, there is minimum redundancy built into the aviation industry's FPI process to prevent human error or other task or workplace factors that can adversely affect inspector performance. Because of these and other similar factors, the Safety Board is concerned that NDI inspections in general, and FPI in particular, may not be given the detailed attention that such a critical process warrants.*

*The Safety Board addressed the issue of human factors in NDI inspector reliability following the Aloha Airlines B-737 accident near Maui, Hawaii, in April 1988. As a result of its investigation of the Aloha accident, the Safety Board issued two recommendations to the FAA that are relevant to the maintenance and inspection issues identified in this case.*

A-89-56

*Require formal certification and recurrent training of aviation maintenance inspectors performing nondestructive inspection functions. Formal training should include apprenticeship and periodic skill demonstration.*

A-89-57

*Require operators to provide specific training programs for maintenance and inspection personnel about the conditions under which visual inspections must be conducted. Require operators to periodically test personnel on their ability to detect the defined defects.*

*In its response to these recommendations, the FAA acknowledged that its Aging Fleet Evaluation Program has highlighted some of the same deficiencies outlined by the Safety Board and that it is addressing these issues as part of regulatory reviews of 14 CFR Parts 65 and 147. The FAA also indicated that the utilization of inspector personnel, and the human factors aspects of such utilization, are also being examined. Based on the FAA's response, these recommendations have been classified as "Open-Acceptable Action."*

*The Safety Board also believes that the manual inspection systems used to inspect the vast majority of aircraft structural and engine components are inherently susceptible to human factors problems that can significantly reduce the probability of detecting a given defect. Automation of NDI is already available with current technology. Automated eddy current, ultrasonic, and FPI equipment can be employed by airline maintenance centers. The Safety Board believes that the FAA should follow through with a research program to identify emerging technologies for NDI that simplify or automate the inspection processes, provide funding to initiate demonstration programs, and encourage operators and others that perform inspections to adopt superior techniques and equipment. The FAA should also encourage the development and implementation of redundant ("second set of eyes") inspection oversight for critical part inspections, such as for rotating engine parts.*

*Subsequent to the Aloha Airlines accident and several other mishaps in which structural problems in high-time air carrier airplanes were identified, it became increasingly evident that the quality of maintenance ultimately depends directly on the performance of line maintenance and inspection personnel. Accordingly, the FAA has initiated a continuing series of government/industry meetings to address "Human Factors Issues in Aircraft Maintenance and Inspection."*

*The first of these E-day meetings was held in October 1988, and the second was held in December 1988. The first meeting identified communication, in all its forms, as being of considerable importance in aviation maintenance and as a matter in need of attention. The second meeting focused further on issues of "information exchange and communications." A number of recommendations to the FAA resulted from these*



meetings in the areas of communications, training, management regulatory review, and research and development. A third meeting was held in June 1990 that focused on training issues, and additional meetings are planned by the FAA to address other aspects of the maintenance and inspection problem. FAA representatives have indicated that the results of these meetings will serve as prospective contributions to its Human Factors Research and Development program and to its regulatory review activities.

The Safety Board is encouraged by these developments and urges the FAA to continue these worthwhile efforts on an expedited basis with a view toward establishing a constructive dialogue with the key elements of the aviation maintenance community.

## 2.7 Philosophy of Engine/Airframe Design

### 2.7.1 Hydraulic Systems/Flight Control Design Concept and Certification

The three hydraulic systems installed on the DC-10 are physically separated in a manner that is intended to protect the integrity of the systems in a single-event-failure. Hydraulic fluid is isolated between the three independent systems and alternate motive systems and auxiliary systems are provided.

During the investigation of this accident, the Safety Board reviewed alternative flight control system design concepts for wide-body airplanes. The concept of three independent hydraulic systems, as installed on the DC-10, is not unique. Boeing and Airbus have three such systems on some of their most recently certified models. Lockheed and Boeing have also provided four independent systems on some of their wide-body airplanes. The Safety Board can find no inherent safety advantage to the installation of additional independent hydraulic systems for flight controls beyond those currently operating in today's fleet. However, the Safety Board believes that backup systems to the primary hydraulic systems should be developed and included in the initial design for certification. Such backup systems are particularly important for the coming generation of wide-body airplanes. Manual reversion flight control systems are quite likely impractical because of the power requirements to deflect large control surfaces that are heavily loaded. Therefore, the Safety Board recommends that the FAA encourage continued research and development into backup flight control systems that employ an alternative source of motive power.

Additional design precautions could have been taken by Douglas if the potential effect of the distribution pattern and fragment energy levels had been predicted. Engine manufacturers should provide such data to the airframe manufacturers who can then incorporate measures to counter the effects into the airframe design. The problem is complicated by many factors, including the interaction of the nacelle design, engine pylon design, and supporting airframe structure.

During the UA 232 accident sequence, once the fan disk failed and the pieces began to escape the confines of the containment ring, the dispersion of rotor disk and fan blade fragments was altered by contact with

both engine components and the airplane structure. The Safety Board did not attempt to determine the specific origin or trajectory of each fragment that damaged the airplane in flight. For accident prevention purposes and in the course of making safety recommendations, it was sufficient to recognize that catastrophic damage from the failure of rotating parts can originate from any fragment source with sufficient energy to penetrate the airplane's structure.

The Safety Board considers in retrospect that the potential for hydraulic system damage as a result of the effect of random engine debris should have been given more consideration in the original design and certification requirements of the DC-10 and that Douglas should have better protected the critical hydraulic system(s) from such potential effects. As a result of lessons learned from this accident, the hydraulic system enhancement mandated by AD-90-13-07 should serve to preclude loss of flight control as a result of a No. 2 engine failure. Nonetheless, the Safety Board is concerned that other aircraft may have been given similar insufficient consideration in the design for redundancy of the motive power source for flight control systems or for protecting the electronic flight and engine controls of new generation aircraft. Therefore, the Safety Board recommends that the FAA conduct system safety reviews of currently certificated aircraft in light of the lessons learned in this accident to give all possible consideration to the redundancy and protection of power sources for flight and engine controls.

#### 2.7.2 Future Certification Concepts

On March 9, 1988, the FAA issued AC 20-128, in part as the result of a Safety Board recommendation made in 1982. The AC provides for a method of compliance with FARs that require design precautions to be taken to minimize the hazards to an airplane in the event of an uncontained engine or auxiliary power unit failure. The AC defines dispersion angles for fragments that may be released during a fan blade or rotor failure. These angles define impact areas relative to the engine installation based on recorded observations of the results of failures both in service and in tests. The AC also provides a listing of design considerations to minimize damage to critical structural elements and systems in the airplane, and defines the fragment energy levels that can be expected from the failure of a fan blade or predicted pieces of a rotor.

The Safety Board notes that the AC provides the engine/airframe designer with information that had previously been left to the interpretation of the designer. The Safety Board also notes that the initial operational capability of the high-bypass-ratio turbofan engines began in the early 1970's. For almost 20 years, and obviously during the development period of the majority of the wide-body fleet, a recognized interpretation of the regulations concerning hazards related to uncontained engine failures was not published by the FAA. The Safety Board believes that improved industry and FAA research and development programs in the area of uncontained engine failures and their effects will significantly improve the safety of the aviation fleet.

The Safety Board believes that the engine manufacturer should provide accurate data for future designs that would allow for a total safety assessment of the airplane as a whole. It is possible that in the interest of marketing a new engine to an airframe manufacturer, the engine manufacturer may underestimate the potential for failure and resultant damage. Similarly, the airframe manufacturer may not possess the data necessary to estimate the total interactive effect of the powerplant installation on the airframe.

14 CFR 25.901 paragraph (c) states: "for each powerplant and auxiliary power unit installation, it must be established that no single failure or malfunction or probable combination of failures will jeopardize the safe operation of the airplane, except that the failure of structural elements need not be considered, if the probability of each failure is extremely remote". 14 CFR 25.903 paragraph (d) (1) states: "for turbine engine installation design precautions must be taken to minimize the hazards to the airplane in the event of an engine rotor failure or of a fire originating within the engine which burns through the engine case."

14 CFR 25.901 and 25.903 are intended to bridge the gap between Part 25 and Part 33 regulations. An engine manufacturer can meet the requirements of Part 33 for an engine without regard to the airframe requirements of Part 25. The expense involved in designing, certifying, and manufacturing turbine engines requires that engine manufacturers produce engines that may be installed on several different model airplanes. Consequently, the same basic engine is usually installed on airplanes manufactured by several different companies. Each installation has its own inherent safety considerations. The differences between wing-mounted, fuselage-mounted, and tail-mounted installations, and the number of engines present, require specific system safety assessments that are not, currently explicitly required.

Although AC 20-128 provides the airframe manufacturer with a method for compliance with 14 CFR 25.903, it implies that the manufacturer should consider fragment energy levels that only the engine manufacturer can provide, and that compressor and turbine disk segment noncontainment should be considered. However, the AC does not specifically address large fan disk segments. Further, the AC is predicated on a three-piece disk rupture with only 1/3 of the disk penetrating the airplane. The Safety Board believes that in future aircraft certifications, the FAA, when assessing compliance by the airframe manufacturer with 14 CFR 25.903, should require that the engine manufacturer provide, and the airframe manufacturer consider, fragment sizes and energies such as those encountered in this accident.

In addition, in the case of large fragments, such as the fan disc segments, the spread angle or dispersion area as defined in AC 20-128 may be inadequate. This accident demonstrated inconsistencies between the predictions of AC 20-128 and the realities of the actual damage to the airframe in this accident. Also, the fact that there was titanium alloy transferred to the No. 4 banjo frame may mean that the banjo piece moved into the dispersion path. However, it may also mean that the frame was struck by the uncontained fragment of the rotor disk assembly when the fragment was

oriented out of its plane of rotation by unbalanced forces during the separation sequence. If the uncontained fragment is displaced out of plane, the spread angle is then a function of the disk fragment dimensions and should be considered when showing compliance with 25.903. Therefore, the Safety Board recommends that the FAA analyze the dispersion pattern, fragment size, and energy level of released engine rotating parts in this accident and include the results of this analysis, and any other peripheral data available, in a revision of AC 20-128 for future aircraft certification.

Following this accident, the Safety Board attempted to obtain historical data and recent operating experience regarding engine rotating part failures and noncontainment events. The most recent information readily available were the two SAE reports that provided data only through 1983. The Safety Board is concerned that there may not be a central repository for a current and complete data base for engine rotating part noncontainment events. The Safety Board believes that the FAA should review the current reporting requirements for manufacturers and operators to establish a centrally available data base of these events based on operator and engine manufacturer knowledge and inservice experience.

The Safety Board recommends that the FAA establish a system to monitor the engine rotary parts failure history of turbine engines and to support a data base sufficient for design assessment, comparative safety analysis among manufacturers, and more importantly, to establish a verifiable background for the FAA to research during certification review. This system should collect worldwide data by means of the reporting requirements for manufacturers contained in 14 CFR Part 21.3.

## 2.8 Survival Aspects

Prelanding preparation improved the prospects of survivability for those occupants seated in areas where the fuselage remained intact. Passengers were in protective brace positions, seatbelts were tightly fastened, and the cabin was properly secured.

With the exception of two elderly passengers who died of asphyxia from smoke inhalation, all of the occupants in rows 9-21 were able to evacuate in spite of smoke from the postcrash fire. Although most passengers were able to escape without assistance, several passengers stated that they were assisted by other passengers.

The ceiling structure collapsed throughout the fuselage; however, the greatest amount of collapse was found in the area near the left wingbox. Consequently, passengers in that section of the fuselage had less space available in which to extricate themselves from their seats and escape. Thirty three passengers in this section died of smoke inhalation: twelve of those 33 passengers had blunt trauma injuries that may have incapacitated them or slowed their escape; the other 21 persons did not sustain blunt trauma injuries. Escape for those passengers seated on the left side of cabin in rows 22-30 was hampered by the hazardous combination of fuselage crush and immediate exposure to the smoke entering the fuselage. Most passengers on

the right side of the cabin in rows 22-30 were able to escape because there was less crushing in that area.

The other fatalities resulted from blunt force impact injuries. These passengers were located in areas where the structural integrity of the airplane was destroyed during the impact sequence.

Current FAA regulations allow occupants who have not reached their second birthday to be held in the lap of an adult. The Safety Board believes that this regulation does not adequately protect occupants under age 2 and urged the FAA to require that infants and small children be restrained in child safety seats appropriate to their height and weight. The Safety Board believes that time consuming flight attendant duties, such as providing special brace-for-impact instructions for unrestrained infants, answering questions about those instructions, and distributing pillows in an effort to enhance the effectiveness of adult lap belts on small children, could be reduced if child restraint was mandatory. Thus, flight attendants could devote more time to other important duties while they prepare the cabin for an emergency landing. The Safety Board issued Recommendations A-90-78 and A-90-79 to address the child restraint issue on May 30, 1990. (See section 4).

When the engine failure occurred, the flight attendants were conducting a meal service. The captain contacted the senior flight attendant and instructed her to prepare the cabin for an emergency landing.

There were two types of cabin preparation contained in UAL's Land Evacuation Checklist: Full Cabin Preparation (over 10 minutes) and Short Notice Emergency Landing Preparation (under 10 minutes). Both types of preparation required the senior flight attendant to determine how much time was available prior to landing. The senior flight attendant determined to keep things "normal" in the cabin and delayed the emergency cabin preparations. Although the delay did not affect the eventual safety of passengers, the Safety Board believes that the senior flight attendant's primary goals should have been to ensure that there was adequate time to complete a full cabin preparation in the face of an obviously severe emergency. The Safety Board recommends that time management of emergency cabin preparations be reiterated in flight attendant emergency training.

## 2.9 Emergency Management

Overall, the established airport/county emergency plan, the recent full-scale disaster drill in 1987, and the nearly 1/2-hour of warning time facilitated the management of the emergency response. The emergency responders arrived at the scene expeditiously, established control, conducted fire suppression, and transported the injured.

The amount of agent used was appreciably more than the FAA index "B" requirements. A DC-10 routinely requires an index "D" airport under Part 139, which requires more than twice the quantity of firefighting extinguishing agents and vehicles required of an index "B" airport. Because of the large fire, the extinguishing agent was expended and the firefighters

were unable to control the fire surrounding the center section of the fuselage. The Safety Board believes that the initial mass application of foam to the cabin section of the inverted fuselage facilitated evacuation of the ambulatory survivors. The Safety Board was unable to determine whether attempts by firefighters to rescue potential survivors would have been successful after the crash because of the rapidly deteriorating survival conditions.

There were several problems with the ability of the ARFF service to control the postcrash fire at the airplane's right wing root because the cornstalks and the wind direction limited the access of ARFF vehicles only to the east side of the inverted cabin. The height and density of the cornstalks also interfered with the firefighters' ability to see debris and passengers. Some of the passengers were on the ground and others were walking between the cornstalks trying to find a path leading away from the burning cabin.

Furthermore, The FAA has no guidance for ARFF operations in unique terrain, where crops can limit visibility and mobility. Considering the visibility constraints on emergency responders and terrain limitations, the FAA should reassess its policy that allows crops to be cultivated on certificated airports. The Safety Board believes that the FAA should ensure that surface obstructions, including certain agricultural crops should not be present where they might interfere with rescue and firefighting activities. A Safety Board recommendation to that effect has been addressed to the FAA. (See section 4).

When the P-18 vehicle's water pump failed during the resupply attempts, no extinguishing agent was applied to the fuselage for about 10 minutes. During this period, the fire at the airplane's right wing root intensified. Soon thereafter, the fire penetrated the cabin and resulted in deep-seated fires within the cabin that could not be reached by an exterior firefighting attack. Despite attempts to advance hand lines to the interior of the airplane, the magnitude of the fire intensified inside the cabin and burned out of control for approximately 2 1/2 hours.

The results of the examination of the P-18 pump revealed a problem with the design of the suction hose assembly. The defect caused the suction hose to collapse, blocking the flow of the water.

Tyndall Air Force Base personnel had detected the same problem in February, 1989. However, the U. S. Air Force did not take immediate action to correct this problem until after the UA 232 accident, 5 months later. There is further concern that all in-service Kovatch P-18 vehicles may not have been properly modified. Even though the Air Force is attempting to distribute modification kits for the P-18 internal hoses, there is no assurance, without an inspection and test of all units, that all the P-18's have been properly modified with the replacement hose assembly.

Of further concern is the absence of requirements for 14 CFR 139 operators to test routinely all fire-service equipment at their full-rated discharge capacity. In the absence of full-capacity testing, deficiencies in

the operation of key fire/service equipment may go undetected until emergency conditions occur.

As vividly demonstrated by the UA 232 accident, all fire-service equipment should be tested at full-rated capacity prior to acceptance by the ARFF service and tested periodically thereafter. This practice would allow routine training opportunities for ARFF personnel and the opportunity to identify equipment deficiencies. Safety Board recommendations regarding emergency equipment management have been addressed to both the FAA and the Department of the Air Force. (See section 4).

## 2.10 Adequacy of Actions Taken Since the Accident

### 2.10.1 CF6-6 Fan Disk Inspection Programs

As a result of the accident, GEAE developed an ultrasonic inspection program to reverify the airworthiness of the CF6-6 engine fan disks. This inspection program was initially issued in SB 72-947 on September 15, 1989. Two revisions of SB 72-947 were issued, one in October 1989, and one in November 1989. The changes in the revisions were to expand the subject population and add disk serial numbers to the list of disks to be inspected.

SB 72-947 defined three categories of disks. Category I disks were from the heat that produced the separated disk; Category II disks were disks from heats with raw material in common with the heat that produced the separated disk (including some heats made with the triple vacuum-melting process); Category III disks were all remaining disks from heats made with the double vacuum-melting process.

Even before the pieces of separated disk were discovered in October 1989, it was believed probable that the fan disk separated as a result of material anomalies. Because material anomalies can be shared throughout a particular heat, soon after the accident GEAE began working with operators to remove from service the six remaining disks from the heat that produced the separated disk. Therefore, by the time SB 72-947 was issued, all Category I disks had been permanently removed from service.

SB-72-947 recommended that Category II disks receive an installed-engine contact-ultrasonic inspection by November 21, 1989, and an immersion-ultrasonic inspection no later than April 1, 1990. It also recommended that Category III disks receive an installed-engine ultrasonic inspection by February 4, 1990, and at intervals of 500 cycles or less, thereafter, and an immersion-ultrasonic inspection no later than December 31, 1990. On September 21, 1989, 6 days after SB 72-947 was issued, the FAA issued AD 89-20-01. In effect, this AD made SB 72-947 mandatory.

The installed-engine contact-ultrasonic inspection (per the AD and SB) is performed on the disk with only minor disassembly of engine components. This inspection is designed to be easily performed and to provide a margin of safety until the more detailed immersion-ultrasonic inspection can be performed. After a disk has been immersion-ultrasonic

inspected, which requires complete disassembly of the disk from the engine, the provisions of AD 89-20-01 and SB 72-947 are met and no further ultrasonic inspections are required for the life of the disk. To amplify, GEAE stated that after the disks were immersion-inspected, the parts were considered to be equivalent to nonaffected parts.

One of the inspection modes used during the contact-ultrasonic inspection is specifically designed to detect a radial/axial crack located on the surface of the bore. This is the orientation and location of the crack that led to the separation of the accident disk. However, neither the contact nor the immersion-ultrasonic inspection mode can detect small cracks in the corner between the inside diameter of the bore and the front face of the bore. A combination of the following three factors makes this location a particularly critical one on the disk:

1. Ultrasonic inspections, by their nature, are not capable of inspecting a volume of material near the entry point of the beam.
2. The presence of the corner radius between the inside diameter of the bore and the front face of the bore makes it difficult to bring an ultrasonic probe close to this corner.
3. The area of highest stress on the disk is the forward corner of the surface of the bore. Therefore, the critical crack size is smallest at this location.

GEAE engineers have demonstrated that, using the contact-ultrasonic inspection, an axial/radial corner slot with a 0.2-inch radius (extending radially and axially a distance of 0.2 inch) generates an indication that is slightly above the rejection limit. The engineers estimated that a crack the size of the slot would grow to failure in about 650 takeoff/landing cycles. Upon initial inquiry, GEAE was unable to demonstrate how large a crack in the forward corner of the bore could be detected using the various inspection modes in the immersion-ultrasonic inspection.

Because the Safety Board was concerned that the ultrasonic inspections alone were insufficient to ensure the long-term airworthiness of the CF6-6 engine fan disks, the Safety Board issued Safety Recommendation A-90-88 to the FAA on June 18, 1990. This recommendation suggested that the FAA develop, with the assistance of GEAE, an alternate inspection method for the bore of the disks and that the FAA require that this alternate inspection be repeated at specified intervals to ensure that developing cracks are detected. (See section 4).

During meetings on September 13, 1990, GEAE demonstrated that a 0.1-inch radius crack in the forward corner of the bore could be detected using one of the inspection modes in the immersion-ultrasonic inspection. GEAE estimated that a crack of this size would grow to a critical size in 1,500 cycles. GEAE stated that all Category II and III disks will be removed from service and replaced with new disks prior to the accumulation of



1,500 cycles after immersion inspection. The replacement program was initiated by the Manager of Customer Service through letter exchanges with user airlines. The Safety Board recommends that the FAA issue an AD to mandate further service limits or methods of inspection to extend residual life on disks inspected per AD-89-20-01.

Also related to CF6-6 fan disk inspections, on June 14, 1990, a few days before the Safety Board issued Safety Recommendation A-90-88, GEAE issued a revision to the CF6-6 engine shop manual, inserting provisions for an eddy current inspection of the bore area of the fan disk. Because the shop manual is a mandatory part of operators' FAA-approved maintenance programs, the eddy current inspection of the bore is required, along with an FPI of the entire disk, every time the disk is separated from the fan module.

The Safety Board believes that the eddy current inspection can detect a much smaller surface crack in the forward corner of the bore of the disk than the ultrasonic inspections. Even though the eddy current inspection is not required at specific cyclic intervals, as suggested in recommendation A-90-88, a typical disk would be expected to become a piece part and to be inspected a least several times before reaching its life limit of 18,000 cycles. Therefore, the Safety Board believes that the inclusion of the eddy current inspection in the CF6-6 engine shop manual satisfies the intent of recommendation A-90-88.

#### 2.10.2 Hydraulic System Enhancement

The Safety Board recognizes the value of the hydraulic system enhancements for the DC-10 in the unlikely event that another DC-10 experiences similar damage to the horizontal stabilizer as a result of a No. 2 engine failure. The isolation of hydraulic system No. 3 forward of the empennage has been demonstrated through simulator testing and during actual flight tests at a safe altitude to provide acceptable limited airplane controllability. However, it must be pointed out that a leaking system No. 3 hydraulic line or component could cause the system to shut off system No. 3's hydraulic power to the empennage while system No. 1 and system No. 2 may be functioning normally. The enhancement is designed to alert the flightcrew to any isolation of system 3 if such a situation occurs.

The Safety Board notes that the incorporation of the flow rate sensing fuses on some DC-10 airplanes may provide an interim measure of safety until the installation of the electrically operated shutoff valve can be completed. Again, the Board notes that in the unlikely event of a No. 2 engine failure similar to the UA 232 accident, the fuses may provide for limited additional controllability. The design of the fuse system enhancement requires that the flow through the fuses be in excess of 15 gallons per minute. The fuses do not function at lower flow rates, and therefore the fuses will not guarantee protection against an open or breached hydraulic line if the flow is less than 15 gpm as might occur if a broken line is pinched.

In summary, the hydraulic system enhancements provided by Douglas and mandated by the FAA appear to protect the airplane in the unlikely event

of a similar No. 2 engine catastrophic failure. In other failures involving the hydraulic systems and the No. 1 and No. 3 engines, the enhancements do not provide any additional margin of safety. The vulnerability of the DC-10 or other wide-bodied airplanes in the event of such failures is not known.

### 2. 10. 3 Industry Task Group Efforts

The Systems Review Task Force (SRTF) originated after the UA 232 accident. The charter of the group, as noted from an Air Transport Association memorandum to the Transport Aircraft Safety Subcommittee and FAA Research and Development Advisory Committee in December 8, 1989, stated in part: "... The charter of the SRTF is to: determine possible design concepts that will provide alternative means of control of flight critical functions in the event of total loss of all (normal) redundant systems which provide that control regardless of the probability of such loss." In addition, the SRTF was asked to consider the need for improved engine particle containment. "Where applicable, the concepts developed by the SRTF should be considered for retrofit of current fleet aircraft."

Boeing, Douglas, Airbus, Lockheed, General Electric, Pratt and Whitney, and Rolls Royce are among the airframe/engine manufacturers represented in the SRTF. Initial reports from the executive steering committee indicate that progress is continuing in all the working groups and that a final report will be available near year's end. The Safety Board supports this effort and is optimistic that the FAA will take an active role in using the committee effort to upgrade design and certification requirements.

As part of the SRTF, an Engine Containment Working Group (ECWG) is also functioning. Of interest is the group's categorization of parts that may not be contained in the event of failure. This concept states that there are parts that cannot be contained by any known means. The group's approach to this problem is to identify the potential parts in this group, to characterize their damage potential to the airplanes, and to pay special attention to them during design, in-service inspection, and repair. The group is also studying the incorporation of improved containment designs and concepts.

The ECWG is also studying inspection reliability. There are currently proposals for a joint industry/regulatory agency program to generate the probability of detection statistics for current inspection techniques and a symposium of manufacturers to address advances in containment technology.

The Safety Board has a vital interest in the work of the SRTF industry group. As evident from the UA 232 accident, inadequate predictions of secondary damage in the area of flight control redundancy have resulted in both this accident and the crash of a B-747 in Japan. There are many other wide-body-type airplanes in the world transport fleet that may benefit from a systems safety review, such as that desired by the FAA Administrator in the charter to the SRTF group. The Safety Board recommends to the FAA that the

*SRTF activities receive maximum encouragement and support to attain the stated objectives.*

#### *2.10.4 Damage Tolerance for Commercial Transport Engines*

*In addition to the separation of the fan disk involved in the UA 232 accident, there have been many examples of life-limited engine components failing before they reached their life limit. The Safety Board believes that this fact demonstrates the need for a revision of the certification, design, and maintenance philosophies for turbine engines. Currently, the certification process for rotating parts in engines assumes that the materials used are free of defects. Thus, manufacturers are not required to assume that undetectable defects are present in the material when the life of the part is calculated and demonstrated. In the case of the fan disk on the CF6-6 engine, GEAE tests conducted at the time of certification demonstrated that a defect-free disk could withstand 54,000 takeoff/landing cycles with no sign of crack initiation. This 54,000-cycle life was reduced to an FAA-approved life of 18,000 cycles.*

*The total number of cycles that a part experiences before failure can be divided into the number of cycles needed to initiate a crack and the cycles needed to propagate the crack to failure. For most defect-free parts, the majority of the parts' total life is in the initiation of a crack, and only a minor amount in the crack propagation phase. However, the presence of a preexisting defect in the material can effectively eliminate the initiation phase of the growth of a crack, leaving only the propagation phase to failure as residual life. This type of preexisting defect was in the fan disk involved in the UAL 232 accident. The hard alpha inclusion became a crack-like defect very early in the operation of the disk. As cycles accumulated, the crack grew larger until failure occurred before the life limit was reached.*

*Because of these concerns, the Safety Board, on June 18, 1990, issued recommendations A-90-89 and A-90-90 to the FAA. They recommended that the FAA require operators to incorporate a damage tolerance philosophy into the maintenance of engine components that, if the components fracture and separate, could pose a significant threat to the structure or systems of airplanes on which they are or could be installed. (See section 4).*

*Under a damage tolerance philosophy, it is assumed that the component material in critically stressed areas contains flaws of a size just below the flaw size detectable during manufacturing inspections. Inspection methods and intervals are thus determined by the detectable crack size per a given inspection method, the stress level at various positions within the component, and the crack propagation characteristics of the component material.*

*A damage tolerance philosophy has been used during the design phase for the structure of airplanes certificated after 1978. Also, older airplane models have an equivalent analysis incorporated into the maintenance of the structure through the Supplemental Structural Inspection Program, compliance with which has been made mandatory through AD's. The Safety Board believes*

that the FAA should begin an effort to incorporate a damage tolerance philosophy into the maintenance of certain critical components in turbine engines for commercial jet transports by investigating and defining the technological areas that need to be advanced. At the very least, the technological advances in damage tolerance assessment, nondestructive inspection, and probability calculations associated with such programs should be emphasized for use in commercial aircraft maintenance programs.

The Safety Board therefore emphasizes the need for action by the FAA and industry on recommendations A-90-89 and A-90-90.

### 3. CONCLUSIONS

#### 3.1 Findings

1. The flightcrew was certificated and qualified for the flight and the airplane was dispatched in accordance with company procedures and Federal regulations.
2. Weather was not a factor in this accident.
3. Air Traffic Control services were supportive of the flightcrew and were not a factor in the accident.
4. The airplane experienced an uncontained failure of the No. 2 engine stage 1 fan rotor disk assembly.
5. No. 2 engine fragments severed the No. 1 and No. 3 hydraulic system lines, and the forces of the engine failure fractured the No. 2 hydraulic system, rendering the airplane's three hydraulic-powered flight control systems inoperative. Typical of all wide-body design transport airplanes, there are no alternative power sources for the flight control systems.
6. The airplane was marginally flyable using asymmetrical thrust from engines No. 1 and 3 after the loss of all conventional flight control systems; however, a safe landing was virtually impossible.
7. The airport emergency response was timely and initially effective; however, cornstalks on the airfield and the failure of the Kovatch P-18 water supply vehicle adversely affected firefighting operations.
8. The FAA has not adequately addressed the issue of infant occupant protection. The FAA has permitted small children and infants to be held or restrained by use of seatbelts during turbulence, landing, and takeoff, posing a danger to themselves and others.

9. Separation of the titanium alloy stage 1 fan rotor disk was the result of a fatigue crack that initiated from a type 1 hard alpha metallurgical defect on the surface of the disk bore.
10. The hard alpha metallurgical defect was formed in the titanium alloy material during manufacture of the ingot from which the disk was forged.
11. The hard alpha metallurgical defect was not detected by ultrasonic and macroetch inspections performed by General Electric Aircraft Engines during the manufacturing process of the disk.
12. The metallurgical flaw that formed during initial manufacture of the titanium alloy would have been apparent if the part had been macroetch inspected in its final part shape.
13. The cavity associated with the hard alpha metallurgical defect was created during the final machining and/or shot peening at the time of GEAE's manufacture of the disk, after GEAE's ultrasonic and macroetch manufacturing inspections.
14. The hard alpha defect area cracked with the application of stress during the disk's initial exposures to full thrust engine power conditions and the crack grew until it entered material unaffected by the hard alpha defect.
15. General Electric Aircraft Engines material and production records relevant to CF6-6 stage 1 fan disk S/N MPO 00385, which was the failed disk, were incomplete.
16. Regarding the existence at General Electric Aircraft Engines of two S/N MPO 00385 disks, an outside laboratory had possession of the disk, which was rejected for an ultrasonic indication at the time that the disk that eventually separated was receiving its final processing on the production line. Therefore, the two S/N MPO 00385 disks were not switched at the manufacturing facility.
17. General Electric Aircraft Engines disk manufacturing records and associated vendor-supplied documents, together with the system for maintaining and auditing them, did not assure accurate traceability of turbine engine rotating components.
18. United Airlines fan disk maintenance records indicated that maintenance, inspection, and repair of the CF6-6 fan disk was in accordance with the Federal Aviation Administration-approved United Airlines' maintenance program and the General Electric Aircraft Engines' shop manual.

19. A detectable fatigue crack about 0.5 inch long at the surface of the stage 1 fan disk bore of the No. 2 engine existed at the time of the most recent United Airlines inspection in April 1988 but was not detected before the accident.
20. The discoloration noted on the surface of the fatigue crack was created during the FPI process performed by UAL 760 cycles prior to the accident, and the discolored area marks the size of the crack at the time of this inspection.
21. The inspection parameters established in the United Airlines maintenance program, the United Airlines Engineering Inspection Document, and the General Electric Aircraft Engines shop manual inspection procedures, if properly followed at the maintenance facility, are adequate to identify unserviceable rotating parts prior to an in-service failure.

### 3.2 Probable Cause

The National Transportation Safety Board determines that the probable cause of this accident was the inadequate consideration given to human factors limitations in the inspection and quality control procedures used by United Airlines' engine overhaul facility which resulted in the failure to detect a fatigue crack originating from a previously undetected metallurgical defect located in a critical area of the stage 1 fan disk that was manufactured by General Electric Aircraft Engines. The subsequent catastrophic disintegration of the disk resulted in the liberation of debris in a pattern of distribution and with energy levels that exceeded the level of protection provided by design features of the hydraulic systems that operate the DC-10's flight controls.

## 4. RECOMMENDATIONS

As a result of its investigation of this accident, the National Transportation Safety Board makes the following additional recommendations:

--to the Federal Aviation Administration:

Intensify research in the nondestructive inspection field to identify emerging technologies that can serve to simplify automate, or otherwise improve the reliability of the inspection process. Such research should encourage the development and implementation of redundant ("second set of eyes") inspection oversight for critical part inspections, such as for engine rotating components. (Class II, Priority Action) (A-90-167)

Encourage research and development of backup flight control systems for newly certificated wide-body airplanes that utilize an alternative source of motive power separate from that source used for the conventional control system. (Class II, Priority Action) (A-90-168)

*Conduct system safety reviews of currently certificated aircraft as a result of the lessons learned from the July 19, 1989, Sioux City, Iowa, DC-10 accident to give all possible consideration to the redundancy of, and protection for, power sources for flight and engine controls. (Class II, Priority Action) (A-90-169)*

*Analyze the dispersion pattern, fragment size and energy level of released engine rotating parts from the July 19, 1989, Sioux City, Iowa, DC-10 accident and include the results of this analysis, and any other peripheral data available, in a revision of AC 20-128 for future aircraft certification. (Class II, Priority Action) (A-90-170)*

*Conduct a comprehensive evaluation of aircraft and engine manufacturers' recordkeeping and internal audit procedures to evaluate the need to keep long-term records and to ensure that quality assurance verification and traceability of critical airplane parts can be accomplished when necessary at all manufacturing facilities. (Class II, Priority Action) (A-90-171)*

*Create the mechanism to support a historical data base of worldwide engine rotary part failures to facilitate design assessments and comparative safety analysis during certification reviews and other FAA research. (Class II, Priority Action) (A-90-172)*

*Issue an Air Carrier Operations Bulletin for all air carrier flightcrew training departments to review this accident scenario and reiterate the importance of time management in the preparation of the cabin for an impending emergency landing. (Class II, Priority Action) (A-90-173)*

*Issue an Airworthiness Directive to mandate service life limits or recurrent inspection requirements on GEAE CF6-6 engine stage 1 fan disks inspected in accordance with AD-89-20-01. (Class II, Priority Action) (A-90-174)*

*Issue an Airworthiness Directive based on the GEAE CF6-6 Engine Service Bulletin 72-962, pertaining to 119 stage 1 fan disks made from ALCOA forgings, to mandate compliance with the intent of the service bulletin by all operators. (Class II, Priority Action) (A-90-175)*

--to the Air Transport Association:

*Encourage member operators to incorporate specific maintenance inspection techniques in their maintenance manuals and maintenance contracts that simplify, automate, and provide redundant ("second set of eyes") inspection oversight for critical part inspection, such as for rotating engine parts. (Class II, Priority Action) (A-90-176)*

--to the Aerospace Industries Association of America, Inc.

*Encourage members to incorporate specific maintenance inspection techniques and inspection equipment in their service manuals that simplify, automate, and provide redundant ("second set of eyes") inspection oversight for critical part inspection, such as for rotating engine parts. (Class II, Priority Action) (A-90-177)*

Also, during the course of this investigation, the National Transportation Safety Board issued the following safety recommendations to the Federal Aviation Administration:

On August 17, 1989

Conduct a directed safety investigation (DSI) of the General Electric CF6-6 turbine engine to establish a cyclic threshold at which the fan shaft and the fan disks should be separated and inspected for defects in the components. The DSI should include a review and analysis of:

- (a) the certification, testing and stress analysis data that were used to establish the life limits of the fan disks and fan shaft components and the recommended inspection frequencies for these components;
- (b) the manufacturing processes associated with the production of the fan assembly and fan forward shaft;
- (c) metallurgical analysis of the front flange of the fan forward shaft in which cracks were recently discovered;
- (d) the maintenance practices involved in the assembly and disassembly of the fan disks and the fan forward shaft for the potential to damage the components during these processes;



- (e) *nondestructive inspection of spare fan disks and fan forward shafts beginning with those components with the highest number of cycles in service; and*
- (f) *nondestructive inspections of fan disks on installed engines that may be performed by an approved inspection procedure. (Class I, Urgent Action) (A-89-95)*

*Following completion of the directed safety investigation of the General Electric CF6-6 turbine engine discussed in A-89-95, issue an airworthiness directive to require appropriate inspections of the fan disks and the fan forward shaft at appropriate cyclic intervals. (Class I, Urgent Action) (A-89-96)*

*Evaluate, because of similarities in design, manufacture, and maintenance, the need for a directed safety investigation of all General Electric CF6-series turbine engines with the objectives of verifying the established life limits for rotating parts of the fan modules and establishing appropriate cyclic inspection requirements for these parts. (Class II, Priority Action) (A-89-97)*

*These recommendations were classified as "Closed-Superseded" by other recommendations issued on June 18, 1990.*

*On May 30, 1990*

*Revise 14 CFR 91,121 and 135 to require that all occupants be restrained during takeoff, landing, and turbulent conditions, and that all infants and small children below the weight of 40 pounds and under the height of 40 inches to be restrained in an approved child restraint system appropriate to their height and weight. (Class II, Priority Action) (A-90-78)*

*Conduct research to determine the adequacy of aircraft seatbelts to restrain children too large to use child safety seats and to develop some suitable means of providing adequate restraint for such children. (Class II, Priority Action) (A-90-79)*

*The FAA Administrator responded to Safety Recommendations A-90-78 and -79 on August 6, 1990. Regarding A-90-78, the FAA issued a Notice of Proposed Rulemaking (NPRM) on February 22, 1990, for child restraint system provisions. The Safety Board is evaluating the response.*

On June 18, 1990

- 1) Develop, with the assistance of General Electric Aircraft Engines, an alternate method of inspecting the bore area of the CF6-6 engine fan Stage I rotor disks for the presence of surface cracks; issue an Airworthiness Directive to require that these disks be inspected with this method on an expedited basis, that disks found to have cracks be removed from service, and that the inspection be repeated at a cyclic interval based upon the crack size detectable by the inspection method, the stress level in the applicable area of the disk, and the crack propagation characteristics of the disk material. (Class I, Urgent Action) (A-90-88)
- 2) Evaluate currently certificated turbine engines to identify those engine components that, if they fracture and separate, could pose a significant threat to the structure or systems of the airplanes on which the engines are installed; and perform a damage tolerance evaluation of these engine components. Based on this evaluation, issue an Airworthiness Directive to require inspections of the critical components at intervals based upon by the crack size detectable by the approved inspection method used, the stress level at various locations in the component, and the crack propagation characteristic of the component material. (Class III, Longer Term Action) (A-90-89)
- 3) Amend 14 CFR part 33 to require that turbine engines certificated under this rule are evaluated to identify those engine components that, if they should fracture and separate, could pose a significant threat to the structure or systems of an airplane; and require that a damage tolerance evaluation of these components be performed. Based on this evaluation, require that the maintenance programs for these engines include inspection of the critical components at intervals based upon the crack size detectable by the inspection method used, the stress level at various locations in the component, and the crack propagation characteristics of the component material. (Class III Longer Term Action) (A-90-90)
- 4) Require turbine engine manufacturers to perform a surface macroetch inspection of the final part shape of critical titanium alloy rotating components during the manufacturing process. (Class II, Priority) (A-90-91)

The FAA Administrator responded to these recommendations in a letter dated July 31, 1990. The Safety Board is in the process of evaluating the response.

On October 19, 1990

Direct Airport Certification Inspectors to require 14 CFR 139 certificate holders to inspect the suction hoses on Kovatch A/S32P-18 water supply vehicles to verify that they incorporate the modifications described in Kovatch Technical Service Bulletin 86-KFTS-P-18-5 and to immediately remove from service A/S32P-18 vehicles that have not been so modified. (Class II, Priority Action) (A-90-151)

Amend 14 CFR 139 to require airport operators to perform maximum capacity discharge tests of all emergency response fire fighting and water supply vehicles before the vehicles are accepted for service and on a regularly scheduled basis thereafter. (Class II, Priority action) (A-90-152)

Make available to all 14 CFR 139 certificated airports an account of the circumstances of the accident described in Safety Recommendation letter A-90-147 through -155 as they relate to the deficiencies identified with the Kovatch A/S32P-18 water supply vehicle. (Class II, Priority Action) (A-90-153)

Develop guidance for airport operators for acceptable responses by aircraft rescue and fire fighting equipment to accidents in crop environments on airport property. (Class II, Priority Action) (A-90-154)

Require annual airport certification inspections to include examinations of airfield terrain to ensure, where practicable, that surface obstructions, including agricultural crops, do not interfere with rescue and fire fighting activities. (Class II, Priority Action) (A-90-155)

The National Transportation Safety Board issued the following recommendations to the U. S. Department of the Air Force:

On October 19, 1990

Require that Kovatch A/S32P-18 vehicles comply with Kovatch Technical Service Bulletin 86-KFTS-P-18-5 and expedite the distribution of modification kits that will permit compliance with the service bulletin. (Class II, Priority Action) (A-90-147)

Immediately remove from service all Kovatch A/S32P-18 vehicles until they have been so modified. (Class II, Priority Action) (A-90-148)

Require maximum capacity discharge tests of all emergency response fire service vehicles before the vehicles are accepted for service and on an established regular schedule thereafter. (Class II, Priority Action) (A-90-149)

Make available to all operators of Department of the Air Force air bases an account for the circumstances of the accident described in Safety Recommendation letter A-90-147 through -150 as they relate to the deficiencies in the Kovatch A/S32P-18 water supply vehicle. (Class II, Priority Action) (A-90-150)

BY THE NATIONAL TRANSPORTATION SAFETY BOARD

/s/ James L. Kolstad  
Chairman

/s/ Susan Coughlin  
Vice Chairman

/s/ Jim Burnett  
Member

/s/ John K. Lauber  
Member

/s/ Christopher A. Hart  
Member

Jim Burnett, Member, filed the following dissenting statement on the probable cause:

I believe that the probable cause of the accident was:

(1) the manufacture by General Electric Aircraft Engines (GEAE) of a metallurgically defective titanium alloy first stage fan disk mounted on the aircraft's No. 2 engine and the failure to detect or correct the condition;

(2) the failure of United Airlines to detect a fatigue crack which developed from the defect and ultimately led to a rupture of the disk and fragmentation damage that disabled the airplane's hydraulically powered flight control systems; and

(3) the failure of the Douglas Aircraft Company's (Douglas) design of the airframe to account for the possibility of a random release and dispersion of engine fragments following a catastrophic failure of the No. 2 engine.

Contributing to the cause of the accident was the failure of the Federal Aviation Administration's (FAA) certification process to require the DC-10 design to account for the possibility of a random release and dispersion of engine fragments following an uncontained failure of the No. 2 engine.

GEAE did not use premium grade triple-melt titanium in the manufacture of the accident disk. GEAE was at that time in the process of switching to premium grade triple-melt titanium for quality control reasons. Nevertheless, GEAE missed an opportunity to detect the hard-alpha inclusion in the accident disk when it conducted a macroetch test on metal that was to be machined away rather than on the finished fan disk.

The DC-10 was certificated in 1971. In January 1970, the FAA imposed the following Propulsion Special Condition for the DC-10:

*In lieu of the requirements of Section 25.903(d)(1), the airplane must incorporate design features to minimize hazardous damage to the airplane in the event of an engine rotor failure...*

For compliance, on July 1, 1970, Douglas Aircraft answered, in part, as follows:

*The power plants and associated systems are isolated and arranged in such a manner that the probability of the failure of one engine or system adversely affecting the operation of the other engine or systems is extremely remote.*

The FAA responded that the information which Douglas provided concerning protective design features for the DC-10 satisfied the Propulsion Special Condition.

I think that the event which resulted in this accident was foreseeable, even though remote, and that neither Douglas nor the FAA was entitled to dismiss a possible rotor failure as remote when reasonable and feasible steps could have been taken to "minimize" damage in the event of engine rotor failure. That additional steps could have been taken is evidenced by the corrections readily made, even as retrofits, subsequent to the occurrence of the "remote" event.

November 1, 1990



## 5. APPENDIXES

### APPENDIX A

#### INVESTIGATION AND HEARING

##### 1. Investigation

The Washington Headquarters of the National Transportation Safety Board was notified of the United Airline's flight 232 **inflight** emergency within minutes of its occurrence. An investigation team was standing by when notification of the crash was received. The full team departed Washington, D. C. at 2100 hours and arrived in Sioux City at **0100** hours central daylight time the following morning. The team was composed of the following investigative groups: Operations, Human Performance, Systems, Structures, Powerplants, Maintenance Records, Air Traffic Control, Survival Factors, and Aircraft Performance.

In addition, specialist reports were prepared to summarize findings relevant to the CVR, FDR, Metallurgical Subgroup, and chemical residue search.

Parties to the field investigation were the FAA, United Airlines, Douglas Aircraft Company, General Electric Aircraft Engines, the Airline Pilots Association, the International Association of Machinists, and the Association of Flight Attendants.

##### 2. Public Hearing

A 4-day public hearing was held in Sioux City, Iowa, beginning on October 31, **1989**. Parties represented at the hearing were the FAA, United Airlines, Douglas Aircraft Company, General Electric Aircraft Engines, the Airline Pilots Association, the International Association of Machinists, the Association of Flight Attendants, Titanium Metals, Inc., and Aluminum Corporation of America.

## APPENDIX B

## PERSONNEL INFORMATION

Captain Alfred C. Haynes

Captain Haynes, 57, was hired by United Airlines on February 23, 1956. He has 29,967 hours of total flight time with United Airlines, of which 7,190 is in the DC-10. He holds Airline Transport Pilot Certificate No. 1337052, latest issue September 21, 1985, with type ratings in the DC-10 and B727. His most recent first class medical certificate, dated March 8, 1989, contained the limitation, "Shall possess glasses for near vision while exercising the privileges of his airman certificate."

His initial training in the DC-10 was as a first officer and was completed on February 26, 1976. He was type rated in the DC-10 on May 11, 1983. On April 6, 1987, he was requalified as a DC-10 captain after having served as a B-727 captain since September 1985. His most recent proficiency check in the DC-10 was completed on April 26, 1989.

Captain Haynes' flight and duty time the previous 24 hour period was 2 hours 01 minute and 2 hours 30 minutes, respectively; for the previous 72 hours it was 10 hours 39 minutes and 14 hours 9 minutes, respectively. Flight times covering the previous 30, 60, and 90 day periods are: Last 30: 73:45, Last 60: 147:39, Last 90: 212:50.

First Officer William R. Records

First Officer Records, 48, was hired by National Airlines on August 25, 1969. He subsequently worked for Pan American World Airways. His first pilot activity at United Airlines was completion of the United Airlines indoctrination course (PAA Pilots to UAL) on December 26, 1985. He estimated that he had accumulated approximately 20,000 hours of total flight time. United's records indicate that he has accrued 665 hours of flight time as a DC-10 first officer. He holds Airline Transport Pilot Certificate No. 1559572, latest issue July 10, 1984, with type ratings in the L-1011 and DC-10. His most recent first class medical certificate, dated June 14, 1989, was issued with the limitation, "Holder shall possess glasses which correct for near vision while exercising the privileges of his airman certificate."

First Officer Records completed United's DC-10 transition course on August 8, 1988. This was also the date of his last proficiency check.

First Officer Records' flight and duty time the previous 24 hour period was 2 hours 01 minute and 2 hours and 30 minutes, respectively; for the previous 72 hours it was 10 hours and 39 minutes and 14 hours and 9 minutes, respectively. Flight time covering the previous 30, 60, and 90 day periods are: Last 30: 83:13, Last 60: 146:50, Last 90: 211:27.



*Second Officer Dudley J. Dvorak*

*Second Officer Dudley J. Dvorak, 51, was hired by United Airlines on May 19, 1986. He estimated that he had approximately 15,000 hours of total flying time. United's records indicate that he has accumulated 1,903 hours as a second officer in the B-727 and 33 hours as a second officer in the DC-10.*

*Second Officer Dvorak holds Flight Engineer Certificate No. 340306866, dated August 7, 1985, for turbojet. His most recent second class medical certificate was issued on August 22, 1988, with the limitation, "Holder shall possess correcting glasses for near vision while exercising the privileges of his airman certificate.*

*Second Officer Dvorak completed DC-10 transition training on June 8, 1989. This is also the date of his last check ride.*

*Second Officer Dvorak's flight and duty time the previous 24 hour period was 2 hours 01 minute and 2 hours 30 minutes, respectively; for the previous 72 hours it was 10 hours 9 minutes and 14 hours 9 minutes, respectively. His flight times covering the previous 30, 60, and 90 day periods are: Last 30: 46:00, Last 60: 54:11, Last 90: 78:42.*

*Training Check Airman Captain Dennis E. Fitch*

*Training Check Airman Captain Dennis E. Fitch, 46, was hired by United Airlines on January 2, 1968. He estimated that prior to his employment with United he had accrued between 1,400 and 1,500 hours of flight time with the Air National Guard. His total DC-10 time with United is 2,987 hours, of which 1,943 hours were accrued as a second officer, 965 hours as a first officer, and 79 hours as a captain.*

*Captain Fitch holds Airline Transport Pilot Certificate No. 1723162, last issued on April 25, 1989, with a type rating in the DC-10. His most recent first class medical certificate, dated February 10, 1989, was issued with the limitation, "Holder shall possess correcting glasses for near vision while exercising the privileges of his airman certificate."*

*Captain Fitch completed DC-10 second officer training on April 2, 1978. On February 2, 1988, he completed first officer transition training on the DC-10. He completed captain transition training on the DC-10 on April 25, 1989. He was assigned as a DC-10 training check airman (TCA) at United's Training Center in Denver, Colorado.*

*First Flight Attendant Janice T. Brown*

*First Flight Attendant Janice T. Brown, completed initial training in April 1977, and the most recent recurrent emergency procedures training on February 17, 1989.*

*Flight Attendant Barbara A. Gillaspie*

*Flight Attendant Barbara A. Gillaspie, completed initial training in February 1988, and the most recent recurrent emergency procedures training on January 26, 1989.*

*Flight Attendant Timothy B. Owens*

*Flight Attendant Timothy B. Owens, completed initial training in June 1989.*

*Flight Attendant Georgeann Delcastillo*

*Flight Attendant Georgeann Delcastillo, completed initial training in October 1987, and the most recent recurrent emergency procedures training on October 6, 1988.*

*Flight Attendant Susan White*

*Flight Attendant Susan White, completed initial training in May 1986, and the most recent recurrent emergency procedures training on May 24, 1989.*

*Flight Attendant Donna S. **McGrady***

*Flight. Attendant Donna S. McGrady, completed initial training in September 1979, and the most recent recurrent emergency procedures training on September 13, 1989.*

*Flight Attendant Virginia A. Murray*

*Flight Attendant Virginia A. Murray, completed initial training in May 1978, and the most recent recurrent emergency procedures training on January 11, 1989.*

*Flight Attendant Rene L. Lebeau*

*Flight Attendant Rene L. Lebeau, completed initial training in November 1988.*

# HORIZONTAL STABILIZER DAMAGE DIAGRAM

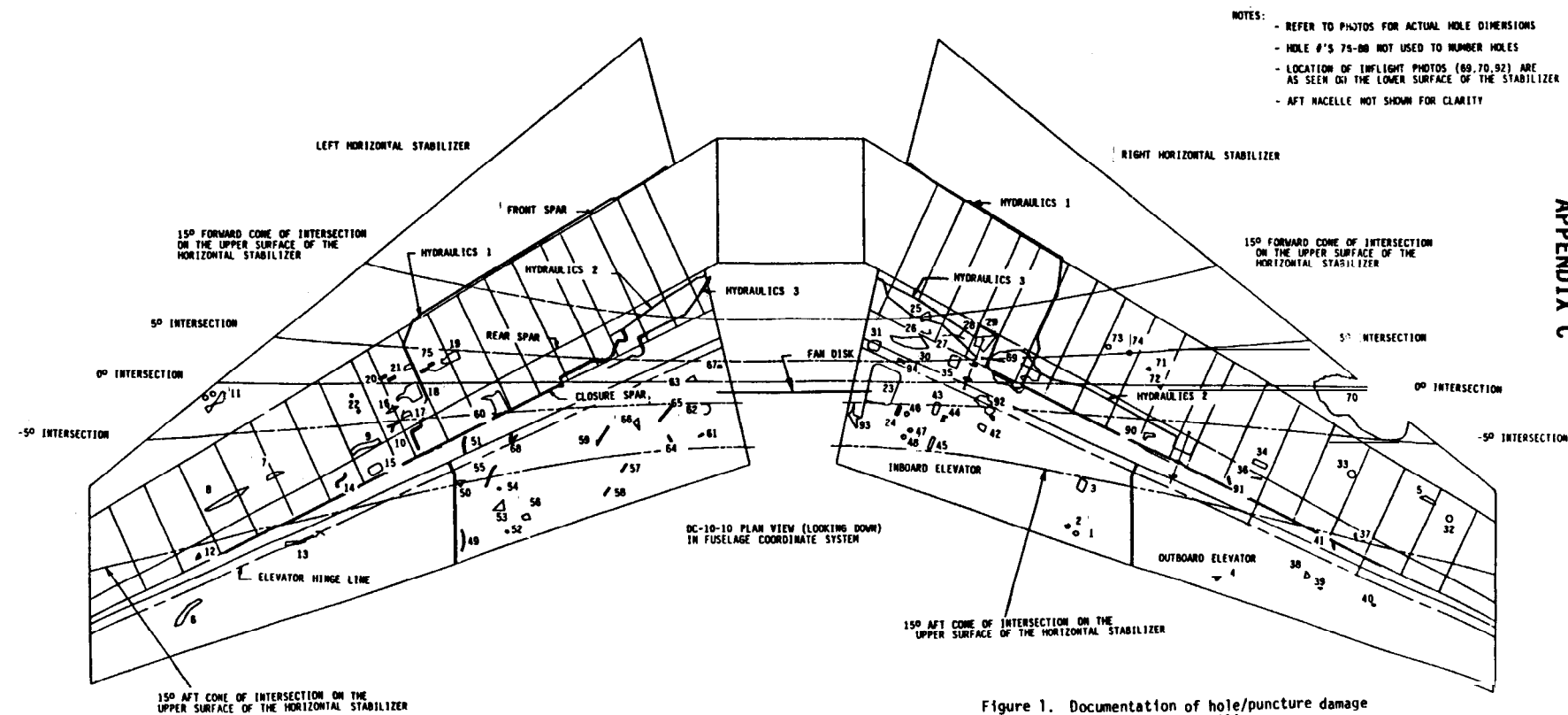

## APPENDIX D

*DOUGLAS AIRCRAFT COMPANY LETTER  
CONTROLLABILITY WITH ALL HYDRAULIC FAILURE***MCDONNELL DOUGLAS**

Douglas Aircraft Company  
3855 Lakewood Boulevard, Long Beach, California 90846-0001

**DALE S. WARREN**

Vice President-Deputy General Manager  
Strategic Business and Technology Development

April 6th, 1990  
CI-JLA-DSW-90-L121

**TO: All DC-10 Operators**

**SUBJECT: Controllability with All Hydraulic Failure**

**Applicable to: All DC-10/KC-10 Aircraft**

After the DC-10 accident at Sioux City, Iowa on 19 July 1989, the U.S. National Transportation Safety Board directed a simulator reenactment of the events leading up to the crash. Flight recorder data was used to replicate the accident aircraft dynamics resulting from the uncontained failure of the aircraft's number 2 engine and damaged occasioned by the explosion, including the loss of fluid in all three hydraulic systems. The purpose of this simulator study was to determine if DC-10 flight crews could be taught to control the airplane and land safely with no hydraulic power available to actuate the flight controls. The result of this study showed that such a maneuver involved many unknown variables, and the degree of uncontrollability during the approach and landing rendered a simulator training exercise virtually impossible. However, the results of these simulator studies did provide some advice which may be helpful to flight crews in the extremely unlikely event they are faced with a similar situation.

Douglas recently offered enhancements for DC-10 hydraulic systems which will preserve some longitudinal and lateral control even with catastrophic in-flight damage to all three hydraulic systems in the tail area such as occurred to the Sioux City accident aircraft. (See DC-10 Service Bulletin 29-128, "Install Hydraulic System 3 Shutoff Valve", dated February 22, 1990). The enhancements consist of three separate installations—an electrically operated shutoff valve in the supply line and a check valve in the return line of the number three hydraulic system, a sensor switch in the number three hydraulic reservoir and the addition of an annunciator light in the cockpit to alert the crew if the shutoff valve has been activated. Hydraulic pressure in system no. 3 will be preserved forward of the valve to provide the crew with longitudinal control by stabilizer trim input at half rate; with lateral control through right inboard, right outboard and left inboard aileron input coupled with some spoiler deflection; with nose wheel steering; and with slats but no flaps. Simulator tests of the Sioux City accident configuration and flight tests of a DC-10 powered only with hydraulic system no. 3 forward of the shutoff valve have enabled Douglas to develop procedures and suggested techniques for flying the aircraft with the enhancement.

Section 1 of this letter discusses the techniques and suggestions developed for use with a complete hydraulic power loss such as occurred near Sioux City. Section

April 6th, 1990  
Page 1 of 8

CI - JLA-DSU-90-L121

2 of this letter discusses the specific suggestions which apply to flying the aircraft with the enhancement operative.

### **1.0 Aircraft Control with Complete Hydraulic Power Loss**

Without hydraulic power, the ailerons will tend to float trailing edge up over a period of time, but there is little observable float on the elevators and spoilers, and none on the rudder. The only remaining means of control to the crew is from the operating wing engines. The application of **asymmetric** power to the wing engines-changes the heading, hence roll angle, and increasing or decreasing power equally on both wing engines has a limited effect on the pitch attitude. It is important to note that the pilot has no direct control of airspeed because airspeed is primarily determined by pitch trim configuration. With this very limited means of control available, the following techniques and suggestions are offered for the specific case of a number 2 engine failure and loss of all hydraulic power:

**1.1 Regain level flight.** Immediately after the failure is apparent, attempt to keep or regain control of the aircraft by conventional control inputs for as long as the hydraulic power lasts. The autopilot and autothrottles should be disconnected and every effort made to level the wings and maintain pitch for level flight.

**1.2 Assess** the aircraft damage by whatever means possible. Weather and other operational considerations permitting, such as day VFR conditions, consider calling for a chase aircraft to advise of the extent of damage. Visual examination from the inside of the aircraft may afford some degree of damage assessment.

**1.3 Use of asymmetric thrust to maintain directional control.** The aircraft may have a tendency to roll in one direction due to damage in the tail area as in the Sioux City accident. Higher thrust on the right wing engine will roll the aircraft to the left and vice versa. To maintain wings level in the accident simulations the right throttle had to be maintained considerably ahead of the left. It was discovered that to minimize the rate of descent, the high throttle must be kept at or near Maximum Continuous Thrust (MCT) and the low throttle must be maintained as high as possible without causing undesired pitch or roll.

**1.4 Phugoid mode.** With no pitch control, the aircraft will naturally tend to oscillate in the pitch axis. The nature of the pitch oscillations must be understood before discussing aircraft control. If the pitch attitude is upset with the aircraft stable in roll and yaw, the airspeed will change depending on the direction of the pitch change. As the aircraft pitch attitude increases (aircraft nose up) the airspeed will decrease, resulting in less lift on the wing and horizontal stabilizer. At the point where there is insufficient lift on the wing/stabilizer combination to maintain the pitch attitude, the nose begins to fall. As it does, the airspeed increases causing lift to increase, to the point where the pitch begins to increase again. This cycle repeats itself over a period of time. This long period pitch oscillation is called the "phugoid mode", a characteristic inherent in all aircraft designs. The degree of "damping", or the time it takes for the pitch oscillations to subside, varies with aircraft design. On the DC-10, this pitch oscillation is eventually damped to low amplitude due to the inherent stability of the aircraft.

## APPENDIX D

C1-JLA-DSW-90-L121

**1.5 Use of thrust for pitch control.** Because the wing engines are mounted below the center of gravity of the aircraft, a net increase in thrust will tend to pitch the nose up and a decrease in thrust will pitch the nose down. Consequently, to control pitch oscillations with wing engine thrust changes, it is necessary to apply power just as the nose is coming down, and to retard power as soon as the nose is rising. (If asymmetric thrust is necessary to maintain wings level, power changes must be made while maintaining the power asymmetry). Judicious and aggressive use of power changes (i.e. jam accelerations followed by rapid throttle chops) are instrumental in helping to dampen the phugoid oscillations. However, care must be taken to avoid aggravating the situation by applying power out-of-phase thereby increasing the amplitude of the pitch oscillations.

**1.6 Choice of Landing Site.** As the aircraft returns to some degree of control using the above techniques, consideration should be given to a landing site. Many factors need to be taken into consideration, such as runway length and width, navigation aids, meteorological conditions, terrain, populated areas, crash-fire-rescue capabilities, and most important, the degree of aircraft control. Given some confidence in the structural integrity of the aircraft and the degree of aircraft control, consideration should be given to remaining airborne to reach a more desirable landing site versus a hasty landing in the immediate vicinity. If a distant landing site is selected, determine the aircraft's capability to maintain altitude enroute to the landing area. Use discretion before extending the landing gear because of the irreversible effect on increased airplane drag, hence decreased range. In addition, consider the fuel remaining and its distribution before dumping fuel to reduce the gross weight.

**1.7 Fuel Transfer.** The fuel distribution may enable the transfer of fuel both fore and aft for C.G. control and laterally for roll control. Lateral fuel transfer to level the wings is desirable because it allows both wing engines to be at the same throttle setting if asymmetric power was required to maintain constant heading. Matched throttles allow full concentration on pitch and facilitates heading changes simply by changing the left and right engine power simultaneously with one hand on both throttles. Longitudinal fuel transfer from the number 2 tank (or aux tanks) to tanks 1 and 3 moves the center of gravity aft, which effectively reduces the trim speed without changing the configuration. A reduction in trim speed is very important because it tends to reduce the landing speed thus enhancing stopping capability.

**1.6 Assessment of Aircraft Control.** Continually assess the controllability of the aircraft and remain alert for any further degradation of control. Attempt small turns and climb or descend to learn the aircraft response to power inputs. Consider attempting a practice landing approach at a lower altitude by maneuvering to a predetermined heading at a specific altitude.

**1.9 Landing Gear Extension.** Gear extension will cause a nose up pitching tendency, thus upsetting the airplane in the pitch axis and changing the natural phugoid oscillation. Consequently, when the landing site has been determined, and before lowering the gear, allow sufficient time for the pitch recovery. Once the initial pitch upset is controlled, the aircraft will tend to be more stable due to the increased drag from the gear. Use the alternate gear extension lever to free-fall the nose and main gears for all DC-10 models. Give consideration to extending the center gear on aircraft so equipped. The extension of the center gear is optional when below the weight limit

C1-JLA-DSW-90-L121

for landing with the center gear retracted. However, use of the center gear may provide some additional braking during the landing roll, and absorb some energy on impact.

**1.10 Approach.** When preparing for the approach note the capability to maintain altitude during the initial approach. To maintain as low a rate of descent as possible, plan for a long flat approach. The initial part of the approach should incorporate the use of all approach aids available at the landing site, as well as heavy reliance on visual cues. If the runway has no ILS, the VOR or ADF guidance may aid in alignment at the initial stage of the approach. Radar vectors may also be helpful at the early stage, particularly in cases of reduced visibility. Attempt to reach the vicinity of the outer marker (or 5 to 7 miles from touchdown) at approach altitude with the gear extended, aligned with the runway, and with the pitch controlled as well as possible. Keep in mind that there is more thrust available at lower altitudes. Jam accelerations followed by rapid throttle chops may be necessary to control pitch without generating additional pitch oscillations as a sustained thrust input would do. If asymmetric thrust is required to keep the wings level, a rolling tendency will occur if both throttles are retarded to idle without maintaining the thrust asymmetry. Also be aware of any tendency for the engines to accelerate asymmetrically. This is more likely to occur when the throttles are moved from idle than from approach power settings.

The final phase of the approach from the outer marker (or equivalent distance) to the runway should be accomplished mainly with visual cues, supported by instrument indications as a reference. If an ILS is available, the raw data may be used to determine the start of descent and to compare altitude to the glide slope. The approach descent profile should be slightly below the glide slope (approximately 1/2 dot) but no higher than 2 1/2 to 3 degrees. A higher glide path means higher descent close to the runway, which will be difficult to arrest. An approach slightly below the glide path should reduce the sink rate and will also require higher approach thrust, which places the engine power in a range to provide quicker response to power changes.

The use of the Flight Director (FD) commands while far out on the approach may be helpful to determine direction and relative magnitude of control (power) input, but insufficient control exists to fly the FD commands at lower altitudes. Consequently, it may be beneficial to bias the command bars from view to facilitate reference to the attitude data on the FD.

**1.11 Ground Effect.** Before discussing the landing, a review of the phenomenon known as "ground effect" will be useful. As an aircraft comes in close proximity to the ground, a slight increase in lift and decrease in drag occurs at an altitude beginning about 1/2 the wing span. Another tendency in ground effect, generally not as obvious, may be a nose down pitch moment as the aircraft enters ground effect, which is a function of sink rate and configuration. The DC-10 begins to enter ground effect at about 100 feet A.G.L. and the effect increases exponentially as altitude decreases. Without elevators, the only means of controlling the ground effect pitch change is with a sharp power advance followed by a throttle retard. This is a matter of judgement and is mentioned as a necessary step in reducing what could be an excessively high sink rate at touchdown. Obviously, an approach above the

## APPENDIX D

C1-JLA-DSW-90-L121

glideslope with a rapid sink rate coupled with ground effect could result in a very hard touch down.

**1.12 Final Approach.** If the final approach is stable from about 500 feet A.G.L., a landing should be attempted, but extreme vigilance is required from all crew members. The pilot may find it useful for the pilot not flying to call radio altitude, sink rate, and sink rate increasing or decreasing trends from the outer marker (or equivalent distance) inbound. As the aircraft nears the runway, sink rate and sink rate trend are sufficient, and in ground effect sink rate trend only. The pilot not flying and the second officer are in a good position to judge pitching tendencies by watching the horizon in relation to the glare shield. This can be critical information when approaching touchdown.

Because the ground effect may increase the rate of descent near the ground, it is apparent that the touch down aiming point must be moved to compensate for this tendency. Simulator trials have shown that if the aiming point is moved toward the far end of the runway the touch down will have a better chance of occurring in the normal first third of the runway.

In an unstable approach when the aircraft is in a phugoid oscillation, three things can happen: (a) the aircraft can touch down on the pitch down phase of the phugoid, which means a hard impact when coupled with a possible pitch down due to ground effect; (b) the aircraft can enter the pitch up phase of the phugoid during final approach and not touch down at all (in which case a go-around should be attempted); or, (c) it can touch down somewhere in between the two extremes. The likelihood of touching down smoothly is highly unlikely. Consequently, it is recommended to attempt only to reduce the rate of descent before touch down as much as possible.

**1.13 Go-Around Capability.** If the final approach is not stable nearing touchdown, a go-around may be attempted by advancing the power and allowing the aircraft to pitch up. Remember that the power is not controlling speed, so only enough thrust should be used to initiate a climb at moderate pitch attitude. Too much pitch could cause the stick shaker to activate and/or the aircraft may stall. Keep in mind that adding power if a power differential was required to keep the wings level, will necessitate that the power differential be maintained to avoid the initiation of roll or a heading change during the go-around. Attempt to level off at a safe altitude and reinitiate the approach as before. If the approach is unstable and insufficient fuel exists for another attempted landing, or for other operational reasons a landing is necessary, it may be advisable to continue the approach and trade the original aiming point on the runway for a more stable and controlled touchdown in close proximity to the runway. In this sense it is possible to choose the landing site, or maintain a controlled stable descent and touch down, but it is extremely difficult to successfully accomplish both simultaneously.

**1.14 Landing.** When entering ground effect with the intention of landing, be aware of, and be quick to respond to, the necessity to add power to keep the nose from falling. Remember that the speed at touchdown will be a function of the phase of the phugoid oscillation, and could be well over 200 knots. It is most important to increase thrust, to raise the nose if necessary thereby decreasing the sink rate--even



C1-JLA-DSW-90-L121

if this results in an increase in touch down speed. Maneuver the power as necessary up to maximum thrust to reduce the sink rate to an acceptable value.

If the final approach has been stable and the sink rate has been slowed, the aircraft will touch down at a pitch attitude approaching 10 degrees. If the aircraft skips back into the air, attempt to ride out the skip or apply power for a go-around, depending on the degree and duration of the skip. If there is no skip or the aircraft returns to the runway immediately, apply full antiskid braking to forcefully bring the nose down. (Brake accumulators will allow full braking even with the loss of all hydraulic fluid.) The wing engines should be placed in maximum reverse immediately after nose wheel touch down while maintaining full braking. Manually modulate the brakes only as necessary for steering, but do not pump the brakes under any circumstances as this will deplete the brake accumulators more rapidly. Steering will not be available from the normal means, but only as a last resort, asymmetric reverse thrust could be used.

Adherence to these recommendations and techniques is by no means a guarantee of a successful landing. However, these suggestions represent the best information available from the studies and empirical simulator results into the nature of flight without hydraulic pressure powering the flight controls.

## **2.0 Aircraft Control with Hydraulic System Enhancement**

When the hydraulic shut off valve closes in response to a hydraulic quantity loss in system 3, hydraulic fluid is preserved for aileron controls using system 3 forward of, but not including the elevators. This provides longitudinal control by means of stabilizer trim with one trim motor (half rate) and lateral control by the inboard ailerons as well as aileron trim. Crew action in response to the illumination of the HYD SYS 3 ELEV OFF light accompanied (or not) by loss of hydraulic quantity is addressed in a recent interim change to the DC-10 Flight Crew Operating Manual (FCOM). The following will address the flyability of the DC-10 with the enhanced hydraulic system, and provide flight crews with the recommendations, techniques, and advice gleaned from simulator and actual flight test evaluations of the enhancement.

The information presented in sections 1.0 through 1.14 above regarding the flight characteristics of the DC-10 without hydraulic control, and the recommendations and techniques for flying and landing in this condition remains valid and is basically applicable to flying the aircraft with the enhanced hydraulic system, with the exception of the control that the enhancement provides in the pitch and roll axis. (If the ailerons were not trimmed and the stabilizer was not used to control pitch, the condition would be identical to the Sioux City aircraft.) It is this control that will be discussed below:

**2.1 Regain Aircraft Control.** If damage similar to the Sioux City accident ever occurs again, attempt to gain/recover aircraft control using conventional aileron input for lateral control, and a combination of power and stabilizer trim for pitch control. It is recommended that the autopilot and autothrottles be disengaged and a wings level attitude held with aileron control. Aileron trim may now be used to trim out the aileron control wheel forces due to the rolling moment (if any) due to aircraft damage. It should be noted that without rudder control (i.e., no fluid in hydraulic

## APPENDIX D

C1-JLA-DSW-90-L121

system 2 for the 3-2 nonreversible motor pump) there will be a slight unbalanced side force that may be easily controlled by a very small bank angle.

The relative ease of establishing roll control, and the use of symmetric throttles now allows full attention to pitch control. As in the case with no hydraulics, the throttles are used in the same manner to control pitch (that is an aggressive advance just as the nose is coming down, or a rapid retard just as the nose begins to rise). But now there is additional pitch control available through the horizontal stabilizer. Even at half rate (about 1/4 degree/second) sufficient trim exists to bring the aircraft under control with the use of a combination of thrust and pitch trim. The most important aspect of the stabilizer trim is the reduction in trim speed down to and including approach speed. Controlling the speed is the most significant factor in accomplishing a successful landing.

**2.2 Stabilizer Trim.** When trimming the stabilizer to make pitch changes, either the wheel trim switches or the suitcase handles may be used. The wheel trim switches must be held momentarily to assure stabilizer movement in either direction. When approaching the desired pitch attitude, it may be necessary to reverse the trim input to stop the motion at the required level. After the first few attempts at trimming it becomes apparent that some anticipation and input reversal is required. The suitcase handles may also be used to trim the stabilizer by placing both handles firmly to at least the first soft detent position (or beyond if necessary). However, this may be distracting because it requires the pilot to alternate his right hand between the throttle and the suitcase handles.

**2.3 Slat Extension.** The initial approach should be flown to the vicinity of the outer marker (or 5-7 miles out) in the same manner as previously discussed. During maneuvering in the terminal area the slats may be extended to allow a reduction in airspeed. Slat extension may require airspeed to be reduced because the slats are now powered by a single hydraulic system. The airspeed should be reduced to the O/RET Minimum Maneuvering speed and the slat handle placed to O/EXT. If the slats do not extend in the normal time of about 10 seconds, it will be necessary to follow published procedures and slow to the 1.3Vs speed for O/RET. Slowly decelerate to the 1.3Vs speed and observe slat extension. There will be a slight nose down pitching moment as the slats extend which is easily controllable by stabilizer trim. The speed may be reduced to the O/EXT maneuvering speed once the slats are extended.

**2.4 Landing Gear Extension.** When approaching the outer marker (or equivalent distance) the landing gear should be extended. Allow sufficient time to accomplish the procedure as outlined in the dual hydraulic failure-system 1 and 2. The alternate gear extension lever should be raised and the gear monitored for normal free fall indications for all model DC-10 aircraft. Free fall of the center gear, on DC-10 aircraft so equipped, should be accomplished if the gross weight requires extension. Observe the normal extension time of about 13 seconds for the main gear and 10 seconds for the center gear. There will be a pitch up tendency as the gear extends and a noticeable drag increase. The nose up pitching moment is easily controlled by the stabilizer trim, and the drag increases are controlled by thrust application. When all required gear have been extended, the normal landing gear lever should be placed down and the alternate gear handle stowed.

C1-JLA-DSW-90-L121

**2.5 Approach Speed and Descent.** Once in the vicinity of the outer marker with the slats extended and the landing gear down, the speed should be reduced from maneuvering speed 0/EXT to an approach speed of 1.3Vs 0/EXT. Speed reduction should be accomplished with a throttle retard and stabilizer trim used to maintain the flight path angle. Passing the outer marker (or equivalent) the flight path angle may be adjusted to establish an approach path on or slightly below a normal glideslope. As previously discussed in section 1.10, a low rate of descent will make the final approach and landing more manageable. The pitch attitude on final will be about 10 degrees ANU and the descent rate about 500 feet per minute.

**2.6 Preparation for Touchdown.** Adjust the touchdown aim point toward the far end of the runway as before, and continue to fly the thrust for speed control and stabilizer trim to maintain the desired pitch attitude/flight path angle. Smooth deliberate throttle adjustments for speed control while far out on the approach will make the task of trimming the stabilizer easier due to the slower than normal rate of trim. Begin the transition from stabilizer trim to thrust for flight path angle control on the final part of the approach (about 500 feet AGL). Aggressive power application (ie rapid accelerations followed by immediate throttle chops) will allow the small changes in pitch attitude necessary to maintain the touchdown aiming point without significantly changing the speed, assuming the approach is stable in the pitch axis. Throttle adjustments may need to be more aggressive as the airplane enters ground effect. Once again, there should be no attempt to accomplish a smooth landing, but simply reduce the sink rate as much as practical without ballooning or skipping.

**2.7 Stopping.** Upon touchdown apply full brake pedal deflection and, as the nose comes to the runway, initiate reverse thrust on the wing engines. Continue to hold full brake deflection and monitor brake system #2 pressure (powered by hydraulic system #3) noting antiskid operation. With the enhanced hydraulics, spoiler panels 3 on each wing will be powered and should be deployed at main gear touchdown. Nose wheel steering is available and should be used for directional control until the aircraft slows to taxi speed.

The above recommendations represent our suggested means of accomplishing a controlled approach and safe landing and are based on the conditions that existed during the simulator and flight tests referenced above. Because of the multitude of unknown variables that could accompany any given set of actual conditions in any future incident, the above procedures may not be optimal for all conditions. However, they do provide a good foundation to use as guidance in a different set of circumstances.



Dale S. Warren  
Vice President-Deputy General Manager  
Strategic Business and Technology Development

srl/SRL

April 6th, 1990  
Page 8 of 8

