

THE 'SIX-PIPS' TIME SIGNAL

In early February, the BBC took over responsibility for the generation of the 'six-pips' time signal, which is broadcast at certain times by all four of our radio networks. The pips had previously been generated at fifteen-minute intervals by the Royal Greenwich Observatory (RGO) at Herstmonceux in East Sussex.

The new time signal equipment is located in Broadcasting House, London. In addition to the six-pips, it also generates EBU and BCD timecode, as well as various frequencies for use in digital audio. The system's main features are described on page 5.



Broadcasting House - the new home for the 'six-pips' time signal.

CONTENTS

BELFAST	
- Further Post Production facilities	19
BRISTOL	
- Design Award for ACED	20
BROADCASTING BILL	
- Additional Services	4
D&ED	
- Coded Equipment Register 1990	2
DIGITAL BROADCASTING (Part II)	
- Transmission Techniques and Standards	14
ENTERPRISES	
- New Transmission Area at Television Centre	II
FILM	
- A Medium or a Style?	8
HDTV	
- The future on display at Ally Pally	10
NETWORK RADIO	
New Time and Frequency distribution system	5
The Emsys computer system	6
NETWORK TELEVISION	
The Telfax display system	7
Transfer of tv facilities from BH to CAR	13
PATENT APPLICATION	
- Auto-tracking antenna system	2
PHILLIPS COMMITTEE REPORT	
- Funding the future	3
RESEARCH DEPARTMENT	
Computer simulation of Signal Processing	6
SAFETY	
- Noises At Work Regulations 1989	2
TRANSMITTER NEWS	2
WOOD NORTON	
The McCrirrick Conference Centre	12

ENG INF.

Edited, designed and typeset
by EIO, Room 707A, HWH.
Tel: LBH 4316

Printed by ETO, Woodnorton

* * * *

The closing date for material to
be published in our next issue is
25 May.

Mike Meyer

TRANSMITTER NEWS

The following services opened between
13 December, 1989, and 16 March:

Television

Nant-y-Moel	Mid Glamorgan
Ross-on-Wye	Heref. & Worc.

Additionally, the St Marks relay at
Tunbridge Wells, Kent, has been modi-
fied to improve the quality of the received
pictures.

FM Radio

Bow Brickhill	Milton Keynes
Buxton	Derbyshire
Chesterfield	Derbyshire
Cornholme	W. Yorkshire
Hebden Bridge	W. Yorkshire
Todmorden	W. Yorkshire

These all carry Radios 2, 3 and 4: the
Buxton FM relay also carries Radio 1.

Radio 1 FM

On 19 December, 1989, Radio 1 FM
services began from Blaenplwyf,
Sandale, Tacolneston and Wrotham (re-
placing the temporary service from
Crystal Palace). At the same time, the
Radio 1 services from Holme Moss,
Sutton Coldfield and Wenvoe stepped
up to full power on new frequencies.
Finally, the Radio 1 FM service from
North Hessary Tor began on 11 February
and, from Black Hill, on 27 February.

Radio 4 FM

The Radio 4 FM service from Blaen-
plwyf began on 19 December, 1989.

Local Radio

As featured in our previous issue, BBC
CWR opened on 17 January, with FM
transmitters at Lark Stoke and Meriden.

D&ED Coded Equipment Register 1990

The new edition of the Coded Equip-
ment Register (formerly 'Registered
Designs & Coded Equipment') is scheduled
for delivery around the end of March.

This book supplements the 1987 Register
(the 'silver book' which contains details
of equipment released during the period
1977 - 1987) and the 1988 Technical
Document Cross Reference (the 'yellow
book'). Both of these should be retained.
However, note that the 1990 book also
includes information previously published
in the 1988 edition of the Coded Equip-
ment Register which can now be discarded.

(The 1988 Register was actually pub-
lished in Spring 1989: it was so called
because it contained information

relating to equipment brought out dur-
ing 1988. It has now been decided that
the title of the Register should instead
reflect the year of publication, hence this
is the Coded Equipment Register 1990.
So don't be concerned that you haven't
seen a 1989 edition!)

Several areas receive their Registers
through departmental distribution
points, so you might need to allow some
time for your copy to reach you. If,
however, it has not arrived by the end of
April, then please contact me on AH 375
and I'll try to sort out the problem.

Peter Jefferson
D&ED Liaison Unit

PATENT APPLICATION

Auto-tracking Antenna System

Chris Gandy of Research Department
has invented an antenna system for
automatically tracking non-continuous
rf signals from a mobile source, such as a
television OB link from a helicopter. It
obviates the need for a separate tracking
link and avoids disturbing the active
picture.

The television signals are received by an
automatic tracking antenna, to main-
tain the strongest signal. During non-
active periods (eg, field blanking
intervals), the antenna beam is elec-
tronically offset in more than one direc-
tion in turn - to check whether antenna

movement is needed.

To avoid confusion due to multipath
problems from the helicopter blades -
these typically occur at frequencies com-
parable to the field rate - all required
offsets are accomplished in a single
interval (such as two line periods in each
of four directions in each field interval).

The invention has been filed as a UK
Patent (No 2 217 137) which was
published on 18th October, 1989. Methods
of offsetting the beam, regenerating the
syncs, and hunting after loss of signal,
are described.

SAFETY Noise at Work Regulations 1989

The Government has been talking about
the effects of noise on worker's hearing for
years. Suddenly, impelled by an EEC
Directive, they published regulations in
November 1989 to come into force on 1st
January 1990.

While the BBC has for a long time had
rules designed to protect people's hearing,
there have been a number of detailed
changes to the law. Within the timescale
imposed, Engineering Management Safety
Committee (EMSC) has only been able to
issue provisional guidance, in the form of
revised Codes of Practice - No 7: *The Use*
of Headphones in *the BBC* and
No 11: *High Sound Levels*.

The new regulations were written to
cover every industrial situation and were
not drafted with our sort of work in mind.
(When they say heavy metal, they mean
drop-forging rather than Iron Maiden or
Guns n' Roses!) In order to check that we
are following the new regulations
accurately, a Working Party has now been
set up within the Corporation to establish
consistent ways of measuring sound levels
in our particular circumstances. Among
the problems being faced is the question of
measuring sound levels at the ear when
headphones are worn.

Martin Nutt,
Sec to EMSC

FUNDING THE FUTURE

The Phillips Report on *Funding the Future* was discussed at a joint meeting of the Board of Management and the Board of Governors on 25th January. The meeting accepted recommendations which will yield savings of £75m per year. Here, Bill Dennay outlines the impact on Engineering directorate.

The excellence of engineering within the BBC has long been an important element in the Corporation's pedigree, matched by its excellence in programmes. However, even centres of excellence cannot escape the changes affecting the broadcasting scene in general and the BBC in particular.

As the result of the deliberations on the Phillips Report, all directorates of the BBC will have to release significant resources. Engineering Directorate has to meet two specific financial objectives: savings of £1.2m per year in Architectural and Civil Engineering Department and £3.3m per year in Transport.

ACED

The required savings in ACED represents about 25% of their current effort: this will have to be achieved by reducing the in-house resources to an absolute minimum, consistent with the demands of the customer directorates. ACED will remain as a central activity within Engineering directorate, providing expert advice and guidance to users throughout the BBC.

Transport

As we need to ensure that in-house services are efficient and economic, all Transport services (except rigger-driving in support of outside broadcasts) will become subject to competitive tendering from outside suppliers. The required level and quality of transport services will be carefully established in consultation with the customer departments, thus permitting a fair comparison between internal and external tenders. The overriding policy is that if the external service is acceptable and is cheaper, the internal service can be retained only on the basis of the strongest editorial or policy argument.

I must emphasise that the use of the word 'privatisation' in this context is inaccurate and misleading. Privatisation implies that a decision has been taken to use external contractors: no such decision has been taken. In fact, every effort will be made to ensure fair competition between internal and external tenderers.

It is worth emphasising that these savings cannot be achieved solely by higher productivity or efficiency: the customers of ACED and Transport will need to

reduce their requirements in these two areas.

Ware Stores

As the result of the closure of Ware stores, arrangements will be made for the purchase and delivery of goods from external suppliers, whilst retaining the financial benefits of our corporate purchasing power.

Research, Design and Equipment

As a matter of policy, Engineering directorate should not undertake any work that is either unnecessary or already being undertaken outside the BBC. It is necessary to scrutinise the activities of Engineering directorate with this policy in mind. In particular, in consultation with the customer directorates, the minimum level of resources required in Design & Equipment Department will be confirmed. The work being undertaken at Research Department will also be reviewed, taking full account of the needs of the BBC for strategic guidance on engineering matters.

Recruitment and Training

Last December, a Working Party on Engineering Recruitment and Training, led by John Elfes (Chief Engineer Regional Broadcasting Resources), produced an interim report which makes many important recommendations about modifying the roles of engineers and technicians in the BBC. When the individual directorates have analysed the effects of such changes on their working practices, the Working Party will prepare a final report which will include estimates of future training demands at Wood Norton.

In this context, the vocational emphasis of ETD's work must be stressed; we still look to the State to provide the necessary education. Having said that, we will examine whether universities and/or polytechnics can offer suitable alternative sources of training for our staff.

Transmission

Transmission is a notable exception from the review procedure: it is widely acknowledged that major savings have already been achieved in this area and that it would be unfair to demand further savings. One activity which Bert Gallon (Chief Engineer, Transmission) is leading is the review of telecommuni-

cations within the BBC, in both programme distribution and telephone traffic. A saving of £1m per year is required in this area.

The successful move of Transmission's HQ to Warwick has demonstrated the economic and social benefits resulting from relocating staff away from the south-east of England in a carefully planned way. The relocation of some other London-based activities across the Corporation is an issue that will be addressed.

Activity Reviews

The process of reviewing the activities of various departments will be onerous and time-consuming. Bernard Buist (Chief Accountant, Engineering) and I will progress all of the reviews, supported closely by the appropriate heads of departments. It is important that we arrive at the correct conclusions, but I also recognise that rapid conclusions are necessary to dispel any uncertainty amongst staff. I have therefore set a target date of June for completion of the review process, except for the reviews of Transport and ETD which will take longer.

☆ ☆ ☆

In introducing the outcome of the Phillips Report, the Director-General said:

"We *have to take* decisive action if we are to release money to:

be more competitive in *pay in the* expanding broadcasting market, *which* we wish to be;

train *staff* effectively, which we need to *do*; and

maintain *and* improve our programmes to *the* licence payers *who* support us, which we *have* to do if we are to be an effective cornerstone of British Broadcasting *and* win our *franchise* renewal in 1997."

Some difficult decisions will have to be made as a consequence of the Phillips Report, but I am sure that Engineering directorate will rise to the challenge, will maintain its outstanding record of excellence and will help to create a better BBC.

Bill Dennay
Director of Engineering

THE BROADCASTING BILL

The Broadcasting Bill is now wending its way through Parliament. Here, Phil Laven considers the Bill in its present state (in mid March) with particular reference to the provisions for 'Additional Services' :

The Broadcasting Bill is a weighty document: 159 pages with 166 clauses and 12 schedules. To make it thoroughly indigestible, the clauses are full of cross-references to other clauses and previous legislation. Since its publication last December, further clauses have been added. The amended Bill has more than two hundred pages and is now the largest piece of legislation ever generated by the Home Office. As such, I cannot recommend it as bedtime reading, except as a cure for insomnia!

Much of the Bill is concerned with setting up the new regulatory regime for commercial broadcasting. If you have relied on newspaper reports, you could be forgiven for thinking that the Bill is almost entirely about the auctioning process for the franchises for Channel 3 (the new name for ITV). In fact, many elements of the Bill are of direct concern to the BBC, such as Listed Events, the repeal of the 'must-carry' rules for cable services, the Broadcasting Standards Council, the extension of the Obscene Publications Act to broadcasting and the transfer to the BBC of responsibility for collection of the television licence fee. Some new clauses have just been published: privatisation of IBA transmission; copyright in programme listings, and quotas for independent production of BBC television programmes.

Additional Services

The Bill includes provisions for licensing of 'additional services', but even the media specialists have almost ignored this subject. An additional service is defined in the Bill as:

"any *telecommunications* service which is provided by *wireless telegraphy* by means of the use of spare *capacity* on the *signals* carrying any *television* or sound broadcasting service".

The Independent Television Commission (ITC) and the Radio Authority must ensure that spare capacity on broadcast services is used for additional services. Whilst most of this spare capacity is on television services to be regulated by the ITC, the Secretary of State can notify the ITC of spare capacity on BBC services: the ITC would

then offer such capacity to the highest bidder. The Bill contains no information about how the Secretary of State would define 'spare capacity' on BBC services but on 20 February, David Melior (Minister of State at the Home Office) made the following statement in the House of Commons:

"The Bill does not require the Secretary of State to notify to the ITC that BBC frequencies are available for allocation. It merely enables him to do so if he sees fit. The BBC will be allowed to retain sufficient spare capacity to continue to provide its Ceefax and Datacast services at current levels and to allow it to continue to provide subtitling for the deaf, to which I attach great importance. Although the BBC uses most of its spare capacity, there will be some additional capacity for allocation. The Bill therefore provides that capacity can be notified by the Secretary of State to the ITC for allocation."

In response to further questioning from the Opposition about the circumstances in which spare capacity on BBC services would be notified to the ITC, David Melior gave an undertaking that: *"There will be no question of notification of spare capacity to the ITC, save after full consultation with the BBC on all material"*. Such assurances are welcome, but a cynical view is that 'consultation' means different things to different people!

Impact on the BBC

At present, the BBC is permitted to use eleven lines per field for teletext. There is the possibility that two further lines could be made available for teletext, but only if the BBC spends money to develop and install single line ITS equipment throughout its distribution networks. These additional lines could be used to enhance Ceefax or to generate income via Datacast. As the Bill stands, the BBC could be informed that these lines have been declared to be 'spare capacity' for the ITC to sell to the highest bidder. The BBC could thus be put into the strange position of having to bid, in competition with commercial data services, for use of spare capacity on its own services.

BBC engineers have an enviable record of success in developing systems to exploit 'spare' capacity on broadcasting services. These include teletext, Datacast, RDS, NICAM-728 (Digital stereo sound for television), overnight subscription services and LF Teleswitching. The Broadcasting Bill removes the incentive for the BBC to develop further techniques to exploit spare capacity, either for enhancement of public service broadcasting or for commercial purposes.

There are similar provisions for the Radio Authority to license additional services on radio, including BBC transmissions, but it is important to note that RDS is exempt since it provides a service which is 'ancillary to programmes' in the form of tuning information.

Once the ITC or Radio Authority has been notified of spare capacity on BBC Services it would be impossible to reverse that decision, even if the BBC subsequently discovered an important use for that capacity.

Impact on ITV and C4

At present, the teletext services on ITV and Channel 4 are provided by Oracle Teletext, which is jointly owned by the ITV contractors (except TV-am). A subscription teletext service is also provided by Air Call Teletext Ltd., a joint venture of Oracle and Air Call plc.

According to the Bill, holders of licences from the ITC will not necessarily be responsible for the provision of teletext services. The licences for 'additional services' will be awarded to the highest bidder. Apart from subtitling and programme-related services, no mechanism is included in the Bill to ensure the continuation of the existing range of teletext services on ITV and Channel 4: the highest bidder might abandon teletext in favour of transmitting data to commercial users.

In response to concerns about the possible loss of the existing teletext services, David Melior defended the Bill by stating that maximum use of the spare capacity on Channels 3 and 4 would be ensured by proper tendering arrangements. He went on to admit

NETWORK RADIO

New Time and Frequency distribution system

that this procedure may not result in a teletext service on Channels 3 and 4, but he pointed out that, whatever happens, the BBC will be free to continue its Ceefax service.

Oracle launched a campaign against this aspect of the Bill, culminating in a petition from more than 100,000 people for retention of teletext on Channels 3 and 4. In the face of such determined opposition, David Melior announced on 15 March (the final day of the Standing Committee's deliberations):

"We are clear that it would not be sensible to earmark all the spare capacity on the Channel 3 and 4 signals for teletext and not permit it to be used for any other purpose. That would perpetuate the rigidity in the present law, which has frustrated a number of interesting developments. We accept, however, that there is a strong case for ensuring that there will continue to be a commercial teletext service throughout the country. I am glad to announce today that we accept that case."

"We have therefore decided that the ITC should be under a duty to advertise a teletext service using part of the spare capacity on the Channel 3 and 4 signals. The amount of spare capacity to be allocated to this service by the ITC would be subject to the approval of the Secretary of State. The exact amount to be so allocated will be a matter for further careful consideration and consultation."

The ITV companies have been successful in lobbying for continuation of a commercial teletext service, even if it will be restricted to, say, 50% of the current data capacity.

Conclusions

Although the Government has partially relented on the issue of commercial teletext services, there is no sign of any concession regarding spare capacity on BBC services being sold by the ITC or the Radio Authority to the highest bidder.

Phil Laven
Chief Engineer,
Information and Training

A new Time and Frequency distribution system entered service in Broadcasting House on the 5th of February. One of its main functions is to generate the six-pips time signal, previously generated by the Royal Greenwich Observatory (RGO).

Here, Jim McIlroy describes the facilities offered by the new system.

The Time Standard consists of three off-air radio receivers in a triple-redundancy configuration. Two of these are tuned to 1.542 GHz and receive UTC time and date information from the GPS (Global Positioning System) satellite. The third is tuned to 60 kHz and receives British Civil Time from MSF Rugby (or DCF Mannflingen, in West Germany, as a back-up).

The Frequency Standard has at its heart, two rubidium atomic oscillators in a dual-redundancy configuration. Each oscillator is located in a GPS receiver and any drift is automatically corrected by the received GPS signal. This avoids the need for regular calibration of these units. The resulting accuracy and stability is halfway between a conventional rubidium system and that of a caesium system. The system can thus act as the primary timing level in a digital transmission system.

System Facilities

Time signals are generated by the system in various electronic formats. One of these is the well-known Greenwich Time Signal (GTS) which has been broadcast by the BBC since 1924. The six pips are distributed to various areas in BH and other parts of the BBC. Other formats generated by the system are EBU timecode, BCD timecode and 24V

impulse. As EBU timecode is an audio signal, it can readily be networked within a broadcast centre. For example, in Broadcasting House it is used to drive display clocks, tape recorders, digital audio systems and other time-dependent equipment.

Frequency generators are incorporated within the system to provide specific frequencies for use in digital audio: 32,44.1 and 48 kHz, plus 1,2,048,5,8,448,10,12,288 and 16,384 MHz. These generators are locked to the frequency standard using phase-locked loop (PLL) techniques but, should a fault occur with the reference signal, each module is capable of stand-alone operation.

Remote Facilities

Customers at regional BBC sites may obtain time and date information from the system, using a 'dial-up' telephone-access facility. Access is via a Hayes compatible modem and a 300-baud dumb terminal, or a dedicated clock controller incorporating these facilities.

Anyone wanting further details on this system should contact me in Room 101 at Broadcasting House (Tel: LBH 4090).

Jim McIlroy
Radio Projects

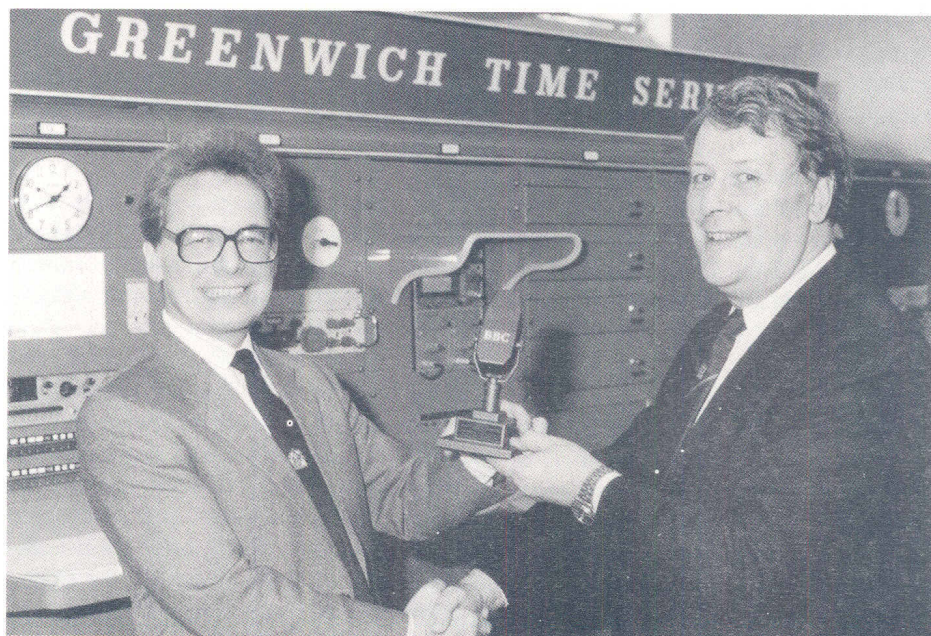

Dr John Pilkington (left) of the RGO receives a model BBC microphone from Duncan Thomas (Director of Resources, Radio), at a special hand-over ceremony at Herstmonceux on the 5th of February.

RESEARCH DEPT.

Computer simulation of Picture Processing

These days, when engineers at Research Department have an idea for a new way to process a television picture (eg, an improvement to a bit-rate reduction technique), they no longer need to build hardware to test it. Instead, they use computer simulation methods.

High-capacity semiconductor stores are deployed to grab a short sequence of real-time video, which is stored as data in computer files. This data is processed on a computer, using Fortran or Pascal, and the results stored in another file. The processed data is then returned to the semiconductor stores to be reconstituted as a video waveform, usually as a continuous repetition of the short sequence.

If the sequence is too short, it either doesn't show any useful movement or it becomes difficult to watch. If the sequence is too long, on the other hand, the amount of storage required becomes excessive and it takes too long to process the data. A comfortable length for subjective analysis is four seconds, or 100 frames. Using a MicroVax computer, it typically takes one hour to process each frame of a normal 625-line picture.

For our Eureka 95 HDTV work, we need to store and process wide-screen (16:9) 1250-line pictures, which contain five times as much data as 625-line pictures. We are therefore in the process of updating our computer picture-processing facilities, to cope with the additional storage and processing requirements.

Last November we acquired two DEC 3100 workstations. These desktop machines incorporate recently-available risc (reduced instruction set) processors, made by the Mips Corporation; each is about twelve times as powerful as a single Micro Vax.

A batch of 1 Mbit DRAMs has been ordered to extend the capacity of our three semiconductor sequence stores, from 120 to 400 Mbytes each. With the three stores multiplexed together, it will be possible to store just over seven seconds of interlaced HDTV pictures in rgb form, at a sample rate of 72 MHz (the highest fidelity standard we use at present).

We are also awaiting delivery of two Solbourne desk-side machines, each of which contains four series-five processors. These are risc processors made by Cypress, of the type used in the Sun Sparc workstation but clocked at 25 MHz. With all four processors in use, the throughput of each machine should be equivalent to around sixty-five Micro-Vaxes. The machine we have borrowed for acceptance trials has been able to reduce a 50-hour Micro Vax job to just over one hour.

Twelve 2 Gbyte Winchester disc drives (totalling 20 Gbyte, when formatted) are being provided for file storage, shared between the two Solbourne machines.

The new disc capacity is five times the total that is currently shared between the three existing Vax machines.

In less than six months, we will have increased the computing power available for picture processing work from: a fairly major share in the use of one Vax 11/750 and two Micro Vaxes, to the equivalent of about 150 Micro Vaxes. So how long will it be before our work expands to fully use the new capacity? The answer is probably not very long, in view of our research programme on enhanced PAL as well as HDTV, and not forgetting Parkinson's Law!

Derek Wright
Data Systems Section, Research Dept.

NETWORK RADIO

The EMSYS computer system

Engineering Operations Radio, based in BH London, is currently responsible for some 30,000 separate items of equipment, used at 3,000 locations. Looking after such a large inventory of equipment has presented three main difficulties:

keeping track of the equipment

determining the relative costs of maintaining the equipment

ensuring that all outstanding maintenance jobs are passed on to the next shift

The Emsys computer system has now solved these problems. It is a database system, written in Informix 4GL, running on a Unix-based computer with twenty terminals. The computer is an Altos 386/2020 with 12 Mbytes of ram, 600 Mbytes of hard disc, a 150 Mbyte tape streamer and a 1.6Mbyte floppy disk. In addition, the system was supplied with the Uniplex suite of word processing, spreadsheet, database and electronic mail programs. These offer total compatibility with the Informix database, enabling easy interchange of data.

Emsys is powered by an Uninterrupted Power Supply (UPS) and has now been

running for a year without any significant problems. Over this period, the system has recorded some 24,000 jobs with 56,000 actions taken. The stored records enable costs to be accumulated by assets and locations. Hence, the system can provide early warning of uneconomic or unreliable assets or locations.

A major additional facility has just been ordered from The Accounting House Group, of Camberley, who installed the system. It will allow the loaning of portable facilities to become a chargeable activity. All equipment in the Facilities Centre will be bar-coded and the computer will administer the booking, issuing and returning of equipment and consumables (batteries, tapes, etc). User departments in Radio will thus become fully accountable for their use of portable facilities!

Summing up, Emsys has turned out to be a very successful system which has enabled the department to keep a much tighter rein on maintenance activities.

Peter Guest, ESM
Network and Basement Studios
Engineering Operations Radio

NETWORK TELEVISION

The Telfax Information Service

Telfax is a new electronic information service for staff in Network Television. It became operational on the 5th of February and uses vision circuits to distribute pictures (with accompanying sound) and a full teletext service to Network Television premises in west London.

The service is currently available to staff in Television Centre, Woodlands, Centre House, Lime Grove, Kensington House/Grove, Union/Threshold Houses and the Television Theatre. There is also a feed to News and Current Affairs staff in the TC Spur.

While the main information is provided via teletext, the system also carries selected teletext pages 'in-vision', in the same manner as Ceefax-in-Vision and Pages from Ceefax on BBC1. At other times, the base band video channel carries VHS/ S-VHS recordings of programme Previews, Press Launches, and occasional management speeches (or interviews) for the benefit of staff.

The main originating equipment is sited in the Press and Publicity Office at Television Centre. It consists of a computer trolley which holds the SofTel InText 125-page text system, along with various pieces of ancillary equipment. A colour ink-jet printer provides hard copy of the teletext pages, for record purposes.

The area has two incoming audio and video programme circuits from the Central Apparatus Room (CAR) plus a Black and Burst reference feed. Outgoing, there is an audio-video feed to CAR, plus a data output feed. Two Philips tv receivers act as audio-video monitors while an audio cassette machine enables staff announcements to be relayed.

The output signals are equalised in CAR and distributed to London Television premises in several ways, according to location. Methods

include: straightforward baseband distribution; modulation onto local rf cable systems and, later this year, mono sound-in-sync distribution via fibre optic channels to Sulgrave House, North Acton Centre, Kendall Avenue/Park Western, TFS and Windmill Road.

The next stage of development is the feed to Elstree Centre, for which equipment is being manufactured at present. Due to the distance from TC, it was decided that only a data feed of teletext be sent, using a DataCast channel (encrypted) over BBC1 or 2. The received data will be loaded automatically into a similar terminal to that in the Press and Publicity Office at Television Centre. Press Office staff at Elstree will be able to supplement the incoming Telfax pages with additional pages, composed locally. They will have local control over which in-vision teletext pages are distributed around Elstree Centre, and will also

have facilities to play back Telfax videos.

At all sites in west London with existing rf distribution systems, considerable additional outlets have been provided so that tv sets can be situated in public as well as work areas. Up-to-date items of BBC information, both 'serious' and 'light', will be communicated to staff by means of the in-vision headlines on public-area tv sets. At or near work points, staff will have access to full teletext receivers, thus enabling them to obtain the rest of the information provided.

Telfax co-ordinator, Frances Owen (who used to work on Ariel), would be pleased to hear from anyone with suggestions that will enhance the system to the benefit of all. She can be contacted on TC 3367.

M A Lyons, Project Leader
Central Systems Group, P&ID Tel



Frances Owen at the Telfax terminal.

FILM - a Medium or a Style?

Film Production Resources held Open Days in mid December to commemorate forty-plus years of film-making in the London Borough of Ealing. Over three thousand people attended this very interesting exhibition which gave a glimpse into the history of 'film-making' in television. Exhibits included Dr Who rubber monsters, colourful period costumes and a huge range of camera equipment and accessories - from vintage to ultra-modern.

Here, Wait Denning describes the equipment used by Film department over the years and gives us an insight into the direction which the technology is moving.

The Ealing Film Studios have never been opened to the public since the BBC bought them in 1956 and, I must admit, it was really pressure from Ealing Borough Council which made this event possible. However, the collection of old and new equipment along with faces past and present, makes me stop and ponder what the future of Ealing's operations will be and indeed, to review the progress that has been made in the last forty-odd years.

When the BBC moved in, much of the Ealing Studios equipment was taken over as a part of the deal. Original camera and lighting equipment still exists, some hidden in dark corners of the studio site and some on permanent loan to the National Museum of Film,

Photography and Television in Bradford. A 35mm Mitchell Camera made the journey down the M1 especially for the Open Days and, just for comparison, Technicolor kindly agreed to display their 3-strip features camera which was in use until recently.

Of course, forty years ago, all of the BBC Film Unit's output was 35mm black and white. 16mm was only in use by amateurs and was technically substandard. (Few would describe it as substandard today!). The cameras were very bulky and a trip to location required a large truck.

16mm Film

The turning point, I suppose, was the introduction of a high quality 16mm

lightweight mechanism, which was quiet enough for sound recording, and quick release magazines so that no time was lost in lacing the camera.

The Arri SR11 and Aaton XTR cameras in use today can trace their ancestry to the Arri BL and Eclair NPR but they are much more sophisticated tools with many more electronic controls and accessories. Both are essentially documentary cameras which may be 'dressed up' to become features cameras with the additions of matte boxes, follow focus units, time-code marking and so on.

At the heart of the film camera is, of course, the film stock. Unlike video cameras, a film camera can be updated simply by a development in the film



The display of costumes at Ealing's Open Days.

emulsion and the latest colour stocks are a far cry from those in use when the television service introduced colour in the late 1960s. In recent times new 16mm film stocks - balanced for daylight and artificial light - have been introduced to dispel the myth that little improvement was possible in sharpness and granularity. More dramatic improvements are promised!

Video Cameras

On the video side of the film operation, things have moved at a much greater pace. Portable single cameras (psc) were introduced in 1983 with separate camera and recorder systems based on U-matic technology. These were replaced in 1985 with standard Betacam with 3-tube saticon camcorders which, in turn, were replaced last year with Betacam SP and ccd camcorders. Film Production Resources currently has some twenty of these units and psc represents about a third of our operation. We have just taken delivery of the Sony BVW300 camera, which is the video equivalent of the Arri SR in terms of size and performance.

The Ealing Power Supplies

Any visit to Ealing Studios is incomplete without a look at the magnificent 1930 vintage Ruston diesels which drive the d.c. power supply for the Stages. These engines have put in sterling work but old age, increased demand from long day working on the Stages, and modifications to the cooling systems as a precaution against legionella, have resulted in their being derated to the point where their capacity to generate power is far below current demands.

A new high voltage a.c. power feed is currently being installed, which will more than fulfill the lighting requirements on the Stages; the changeover to a.c. will hopefully be achieved by May. This development will enable the use of a.c. arc lighting (H.M.I., C.I.D.) and dimming equipment, which hitherto has not been possible without the hire of generators.

Film Sound

On the sound side, the days of the 'mag van' which housed a mobile magnetic film recorder were short lived, after the introduction of synchronised Yrinch tape recorders such as the EMI L2. The Nagra, which is still the industry standard, was introduced to Film Department in the mid sixties and is still, in modern form, the backbone of our operation. Recently, R-DA T has made an appearance and looks promising as a

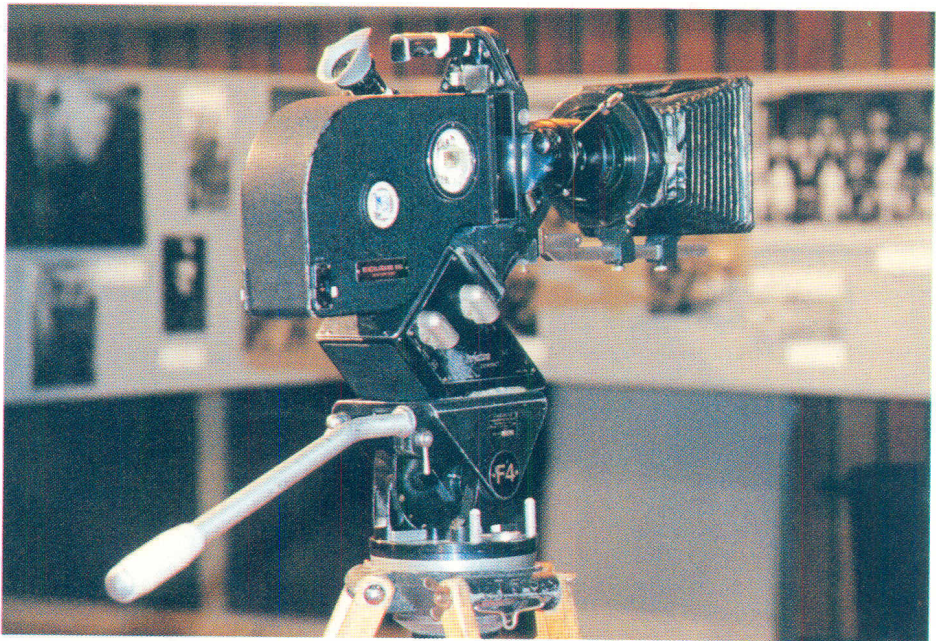

The Eclair NPR 16mm camera.

future format, particularly since there will be less need to rely on synchronising equipment.

The Future

So what of the future? Like other BBC Resource Departments, the scale of the film operation is being reduced as a response to more programmes being made by independent production. However, demand for the use of film crews continues high and the crews themselves have adapted well to the introduction of video technology, such that many are equally at home on either medium. We stand poised to cope with location work on film or video and stage work on film

or single camera video. We have already shot four 35mm feature films - 35mm has returned to Ealing! We believe that film is now a description of a style of working rather than 'silver halide coated triacetate with sprocket holes'!

I hope that those of you who managed to visit our Open Days enjoyed the experience and went away with a little insight into our operation. I suspect that, in view of the success of the public event, we will be repeating the process -perhaps on a more regular basis.

Walt Denning
Head of Film Prod. Resources

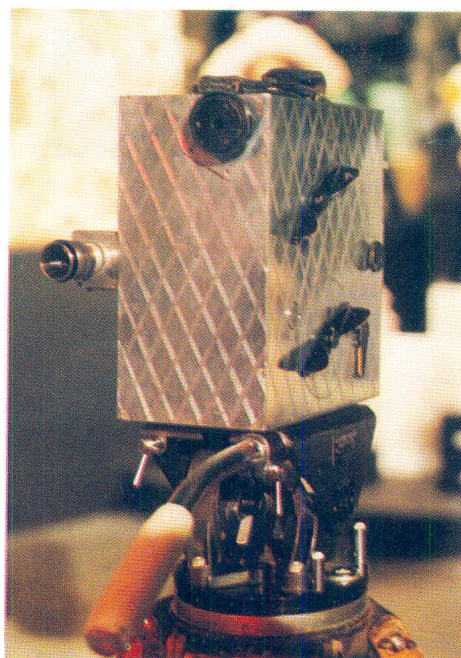

A Sinclair clockwork-driven 35mm camera.

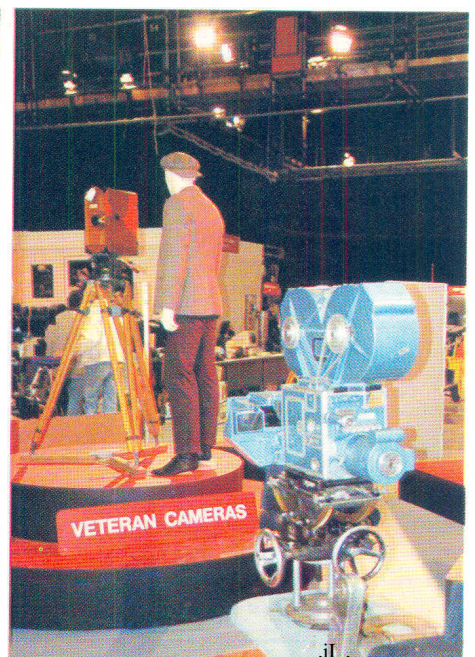

The Technicolor 3-strip camera (foreground).

HDTV The Future on Display at Ally Pally

Research Department has teamed up with the BBC's Open University Production department to produce a new HDTV 1250-line recording entitled *We Return You to the Studio*. It is a short drama, involving three characters, which will be used to help the development of single camera and editing techniques for HDTV, and to provide good experience of surround sound.

This new drama will supplement RD's small but growing catalogue of HDTV promotional material which includes highlights of Wembley football and Wimbledon tennis as well as Tina Turner on Top of the Pops and the Changing of the Guards at Buckingham Palace. More recent HDTV recordings (yet to be edited) include excerpts from Blue Peter, French and Saunders and a special Workshop at Television Centre, as well as the Viennese Night at last year's Proms.

We Return You to the Studio was shot at Alexandra Palace, North London, in late February. The blue plaque outside the main entrance commemorates the "World's first regular electronic High Definition Television Service". It of course refers to the 405-line service which officially started from Ally Pally in November 1936 and which, at the time, was a huge improvement on Baird's original 30-line Nipkow disc system.

Ally Pally remained the BBC1 405-line transmitting site for London until the service moved to Crystal Palace in March 1956. It saw a return to use as a transmitting site in November 1982, when 625-line colour transmissions for the Hornsey area of North London began.

Alexandra Palace was also the home of BBC Television in its formative years. In 1960, the service moved to its new headquarters at Television Centre in West London, followed by Television News in 1969. The last BBC Television residents left Ally Pally about nine years ago - BBC Open University Productions who moved to their new centre in Milton Keynes. The shooting of *We Return You to the Studio* was thus a nostalgic return to Alexandra Palace for the OU production team.



HDTV returns to Ally Pally.

There was of course another reason for their return to Ally Pally - to shoot a programme called *The Future on Display*. This is the eighth programme of an OU course Materials in Action, which will be screened by BBC2 on the 9th of September. It looks at the history of television, from the original 405-line system through to the Eureka 95 High Definition Television system of 1250 lines.

In the future, the choice for manufacturers will lie between Liquid Crystal Displays (LCDs), Projection TVs and

the familiar Cathode Ray Tube (CRT): how do these line up for wide screen home use? The OU programme will show simulative effects that result from deficiencies of display technology, offering viewers an insight into the choices now being examined by manufacturers.

The HDTV Drama

We Return You To The Studio shows what might have happened in the grounds of Alexandra Palace, when kid sister Katy gets bored. She'd turned up as 'Photographer's Assistant' to brother John - but he's now getting too absorbed

in his photo session with girlfriend, Jenny. For young Katy, the scenic attractions of the rose gardens are limited, when compared to what's going on at the end of a trail of tv cables ...

In the historic surroundings of Ally Pally's Studio A, Katy finds a 1930's scenic set with Emitron cameras, and HDTV too. Through the HDTV viewer she sees what might have been, or what might yet be! The story ends with a poignant twist in its tail.

The programme was designed to provide a variety of set-ups for HDTV - exteriors and studio sets, landscapes and close-ups as well as costume and make-up trials.

In a unique partnership with Research Department, both the OD programme and the HDTV drama were directed by OD Producer, Philip Ashby, who in 1988 wrote and directed *The Complete Picture* - the first Eureka HDTV programme ever made. The return to Ally Pally was marked by a special ceremony on the Tuesday, to which selected members of staff and the daily, Sunday and Technical press were invited. In front of around 40 people, the lights of Studio A were ceremoniously switched on again by Tony Bridgewater, who joined Baird's company in 1928 and later became Chief Engineer, Television, in the BBC. He was accompanied by Dallas Bower, producer of some of the first television programmes ever, and Frank Cresswell who was one of the first cameramen.

The HDTV programme is expected to be edited in good time for IBC 90 at Brighton in September.



Tony Bridgewater at the Studio A ceremony, watched by Philip Ashby.



HDTV looks in on the 1930's set.

ENTERPRISES

New Transmission Area at Television Centre

The Enterprises Transmission Area came into operation at Television Centre on 16 January. It comprises two Network Control Systems which provide a service on Intelsat V for BBC TV Europe (transferred from Woodlands) and for *The Enterprise Channel* on the recently-launched Olympus 1 satellite (described in Eng Inf No 38).

This new facility is located next to the Central Apparatus Room (CAR), using space previously deployed as a maintenance workshop. Each transmission system has two bays containing four Ampex Beta SP machines, with the ability to record programmes for time-shifting as well as replaying prerecorded tapes. Captions are provided by Ryley equipment and a VG Genus teletext processor enables in-vision Ceefax to be provided.

At the heart of the system are twin Grass Valley Master 21 presentation switchers. These have sixteen sound and vision channels, each with four audio inputs and four downstream key video inputs.

Each has a comprehensive tape pre-roll facility, which ensures that a preselected vt machine is run up to speed before the vision transition takes place. The Master 21 also provides displays of time, transition status and other system details. Record selection and monitoring are provided on Probel and Broadcast Technology matrices.

Off-Air monitoring facilities have been provided at Woodlands and Television Centre - both in PAL (BBC TV Europe) and D-MAC (Olympus).

Dennis Noble, who had recently retired from Central Systems Group, was re-engaged to specify and manage the installation. The selected contractor, Television Systems Ltd, worked closely with Dennis to design and install the system in the limited time and space available. The project was completed in four months from scheme approval to service date.

Peter Weitzel
Central Systems Group, P&ID Tel

WOOD NORTON

The McCrerrick Conference Centre

At a short ceremony on the 4th of January, former DE -Dr Bryce McCrerrick -opened the new conference centre named after him at Wood Norton. Among the guests were the present DE (Bill Denny), CEIT (Phil Laven) and HACED (Derek Metcalf). ETD is keen to promote its Conference facilities, both within and external to the BBC. Here, Brian Wilkinson describes the facilities and attractions on offer.

A beautiful woodland setting with excellent facilities make Wood Norton the ideal location for your conference. The Hall and Wooded Estate are situated in the Heart of England with panoramic views of the Vale of Evesham and the River Avon winding past the southern edge of the Estate, which is steeped in history.

Between 1898 and 1912, Wood Norton Hall was the prime residence of the French King in exile. A Royal Wedding between the King's younger sister and Prince Charles of Bourbon-Sicily took place here in 1907 at which all the royal families of Europe were represented. The 'golden gates' mimic those of the Versailles Palace and Coats of Arms abound.

The BBC bought the Hall and estate in 1939 and used it as a radio production centre in the early years. In 1946, it became (and still is) the BBC's technical training centre.

General Conference Facilities

We now have a choice of six meeting rooms. Three large rooms can each seat

up to seventy delegates, and all are equipped with audiovisual aids. For smaller, more intimate, meetings we have three seminar rooms. The conference equipment includes video cassette recorders with large screen monitors, 35mm projectors, magnetic white boards, flip charts and 16mm film projectors.

Other equipment can be supplied on request.

Accommodation

We can provide accommodation for up to a hundred delegates, fifty-two in the McCrerrick executive suites, described below, and a further forty-eight in simpler bedrooms with shared bathrooms. The rooms are housed in five modern red brick residences which join to form a series of courtyards and covered walkways. The courtyards and driveways have been landscaped to retain the character of the estate.

Catering

The full spectrum of catering is on offer. We can arrange for you to enjoy a silver service five-course banquet with wine or

you may wish for something simpler from the budget-priced self-service restaurant or a waitress-served buffet in a nearby lounge.

Morning coffee and afternoon tea are served to all delegates.

Sport and Leisure

There is a Sports and Leisure complex which has squash and badminton courts, a multi-gym, table tennis, snooker tables and a lounge bar. For those with outdoor tastes, we can offer a choice of woodland trails through our 170 acres of privately-owned estate, coarse fishing on the banks of the Avon, a swim in our outdoor pool or use of our playing fields and tennis courts.

Transport

Transport to and from the nearest town (Evesham, which is 2Y2 miles away) can be arranged to meet delegates arriving by train. (The 125 Intercity service from London-Paddington takes about one hour and 50 minutes). Also, Birmingham Air Terminal is only 35 miles away and transport can be arranged to meet delegates there too.

The McCrerrick Conference Centre

The building which houses the new centre was originally built in 1957 in one of the most delightful parts of Wood Norton Estate. It has exceptional views of fields and woodland, creating an atmosphere of peace and tranquillity.

When the original construction was designed, shared bedroom accommodation was in vogue. These 52 rooms have recently been gutted and completely refurbished as single-bedded rooms with en-suite facilities, to 3-star hotel standards.

Tea and coffee, etc, is served in a relaxing lounge area, with easy access through patio doors to the outside (patio and adjoining rockery walks yet to be constructed). Buffet meals can be waitress-served in a nearby lounge although a more comprehensive service is



Bryce McCrerrick opens the new Conference Centre, watched by Bill Denny.

available in the Wood Norton Restaurant further up the estate. Groups of up to forty people will be able to use the recently refurbished, wood panelled, Conference Dining Room with the adjacent sherry and coffee lounge - often used by after dinner speakers.

Prices vary according to whether the facilities are to be used by BBC staff or external delegates. For BBC staff, the current daily rate is £27.50 per person, which includes full board and use of the conference facilities.

Other prices are available on request. Whether you have only budget funds available or wish to spend a little more, I am sure we can accommodate you at a price which you will find very competitive.

Even if you don't have a conference to organise, why not come for a weekend in the lovely Cotswolds! Bed & breakfast is only £ 15 per person.

Brian Wilkinson
E.T.Ex.
Wood Norton



Course participants relaxing in the residential area at Wood Norton.

NETWORK TELEVISION

Transfer of TV facilities from BH to CAR

Over the years, most of the audio circuits for use by the Television Service have been routed via Broadcasting House (BH) in London. They were handled at a television control position in what was the London Control Room (LCR), now the Engineering Operations Centre (EOC). Equalisers were set in LCR, according to the results of tests carried out by Transmission operational staff in BH, and the circuits then handed onto Television. Recently, it was decided that Television should take over the operation of their own audio circuits and that this function should be transferred to the Central Apparatus Room (CAR) at Television Centre.

Ordering new BT circuits direct to CAR would have been expensive and may have led to delays. So, instead, around

150 existing circuits have been permanently connected at Broadcasting House; these are used in conjunction with existing BBC circuits between BH and TC. The apparatus for the new permanent circuits is located away from the EOC. Local staff will now only check them if there is a problem, so that the faulty portion of the circuit can be identified and notified to BT if necessary.

At Television Centre, about fifty new circuits have been added to the system. One of the existing uniselector systems in CAR has been rewired and expanded for use solely with outgoing circuits. However, incoming circuits required new equipment and a router, with remote-controlled equalisers, was purchased from NIP. A solid-state record and replay unit (MASS) has also been in-

stalled, to repeat ident messages on outgoing lines which are left 'set up' between periods of use.

Testing of lines is by means of audio sweep-frequency signals, displayed on an oscilloscope, rather than spot frequency tests plotted on graphs and compared with equaliser curves.

The installation was complicated by the need to cooperate with circuit booking departments, so that sufficient circuits were always available to cover the programme schedules. The work in BH was carried out by Richard Eliot, Ted Edwards and Simon Isles Buck and at TC, by Neil Studley and Peter Home.

Keith Sudul, Project Leader
Central System Group, P&ID Tel

DIGITAL BROADCASTING (PART 11)

Transmission Techniques and Standards

In the last issue of Eng Inf we looked at the origination and routing of digital audio and video signals. This time, Rhys Lewis of Design Group, D&ED, takes a look at the transmission of digital data and concludes with a brief examination of a current digital broadcasting system -the Radio Data System (RDS).

In general, the digital signals generated within a studio are not entirely suitable for transmission over anything other than relatively short distances. Generating a more suitable signal from the original data may be viewed as two processes, coding and modulating.

Coding is the process of modifying the structure of the original data in some beneficial way. The process of representing the original signal by a stream of digital data is itself a form of coding. Modulating is the process of modifying a carrier signal in such a way that the changes can be recognised, and the data recovered, at the receiver.

Before we go too much further, it might be as well to restate the principal advantages of digital transmission - so that we can all agree on why it's such a good thing!

Since an audio bit is indistinguishable from a video bit or any other sort of bit (other than by its duration perhaps), then the structure of the transmission system can be independent of the type of signal being carried. This compatibility allows complex transmission structures to be shared by a wide variety of users.

Digital bits are easily regenerated to provide an exact equivalent of the transmitted data. Contrast this with analogue transmission where circuit distortions and noise lead to cumulative signal degradation.

Digital techniques lend themselves to large-scale integration methods, which makes equipment cheap to manufacture.

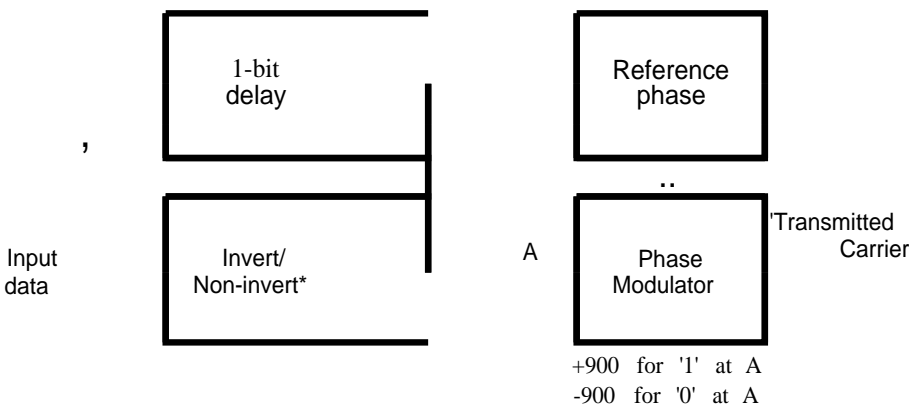

* Previous value of A is inverted when input data is '1', resulting in a phase change at the output. For an input of '0', no inversion takes place and the previous value of A is held, i.e. no phase change.

Figure 2a - Differential coding

- (a) Coding at the transmitter
- (b) Correct demodulation of the transmitted '1'
- (c) Incorrect demodulation results in data inversion

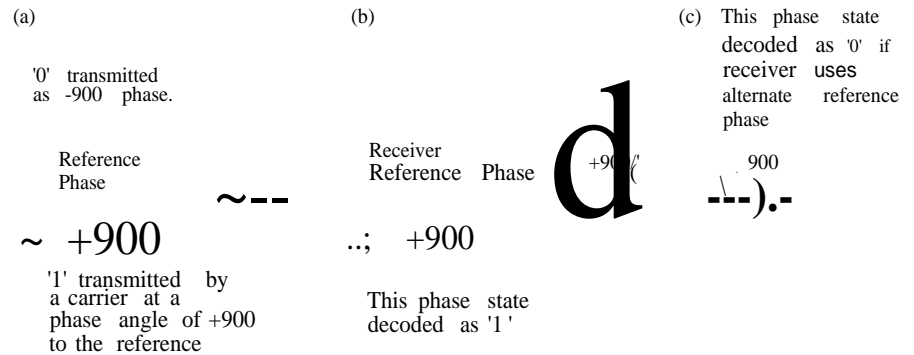

Figure 1 - Effect of reference phase ambiguity in the receiver.

CODING OF DIGITAL DATA

Coding is the process of altering the characteristics of the data to be transmitted in such a way as to impart some desirable trait (or remove some undesirable ones). A change in bit-rate may be involved. Some examples of typical coding processes and the reasons for them are given below.

Parallel-to-serial conversion.
For transmission over long distances, a single path between source and receiver is the most economical method. If the data is not already in serial form then it must be converted. This usually requires the addition of some extra data bits so that the original

parallel data format can be reconstructed by the recipient. This could take the form of specific framing words, inserted at regular intervals into the data stream. The receiver's task is then to lock a 'flywheel' to the repeated frame words in much the same way as a television set locks onto tv syncs.

An alternative approach is to add additional bits to each data word. The bits are chosen so that the new, longer, words obey some rule that can be applied in the receiver. To take a trivial example we could add the two bits '11' to every data word before converting to serial form. The receiver's rule would then be - every word ends in '11'. The receiver could then look for a way of converting the data-stream back to parallel data which satisfied this rule.

Spectral shaping
It is usually necessary to process the raw data in some way such as to modify the distribution of the signal's energy across the frequency spectrum. There are a number of reasons for doing this:

to spread the energy distribution evenly across the transmitted spectrum, in order to minimise potential interference to other users of the transmission channel. The typical output data from an analogue-to-digital converter contains frequent repetition of some words and few occurrences of others. This leads to a rather peaky energy distribution which is generally undesirable.

to guarantee that edges occur with reasonable frequency. This assists the receiver in

DIGITAL BROADCASTING (PART 11)

reconstructing the data clock which it will need to clock out the received data.

to minimise the energy in some parts of the frequency band. Transmission links are usually poor at handling low-frequency information for instance.

The most common form of spectral shaping is usually referred to as scrambling (see 'Energy Dispersal' on page 16). It should not be confused with scrambling used in the sense of secrecy or controlling access to certain data.

Differential coding

Differential Coding is required to sort out a problem with demodulation. We shall see later that one effective modulation method is to vary the phase of a carrier in sympathy with the data. The receiver must recover a reference carrier phase and can then decode the data by comparing the reference phase with the actual carrier phase. Unfortunately, it is very often difficult to establish the reference phase without ambiguity. Let us examine a specific case.

Assume that data is coded as follows - '1' as a phase of +90 with respect to a reference carrier and '0' as a phase of -90 (Fig 1a). All is well if the receiver establishes the correct reference phase (Fig 1b). The data is correctly decoded. However, for an equal number of '1s' and '0s' the receiver can equally well choose the alternative reference phase position shown dotted in Fig 1b. Fig 1c shows that the data is now inverted by the receiver - not an ideal state of affairs.

Differential coding offers a solution (Fig 2a). The coding rule is modified as follows - '1' is coded as a change of phase (from +90 to -90 or vice versa), '0' is coded as no change in phase. Two strategies are possible. The current carrier phase state can be compared against the previous phase state (Fig 2b). This is known as *differential demodulation* and it altogether avoids the need to establish a reference carrier phase. Alternatively, the carrier phase can be compared to a reference phase and successive bit values compared

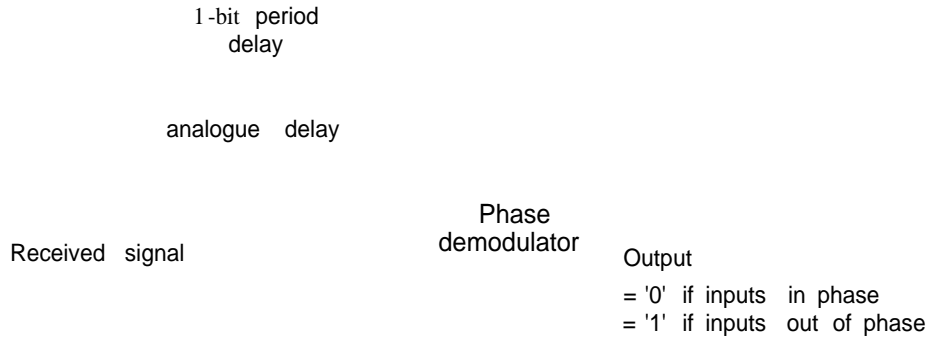

Figure 2b - *Differential demodulation*

(Fig 2c). Two similar bits correspond with no change in carrier phase and hence may be decoded as a data '0'; two dissimilar bits may be decoded as data '1'. This is *differential* decoding and decoded values depend only on the comparison of two bit values and not on the bit polarity.

If all this seems too good to be true, there is of course a price to be paid. Both differential decoding and differential demodulation have poorer performance in the presence of noise at the receiver input.

Error coding.

One of the powerful features of digital transmission is the possibility of adding additional data as a means of detecting and even correcting transmission errors. A simple example of this, *parity checking*, should be familiar to most people. An extra bit is added to each transmitted word so as to keep an even number of '1s' in each word (even parity). Any received words which contain an odd number of '1s' must have at least one error and appropriate action can be taken to deal with the errored word. However, any received word with an even number of '1s' is not necessarily error free. Double errors in a

word would still maintain even parity. Try it as an exercise!

In the case of simple parity checking, it is not possible to determine the location of the error and hence correct it. But it is possible to extend the idea of parity to allow correction (see 'A single-error correcting code' on page 16).

In recent years there have been considerable developments in error correcting codes. The trend is towards the integration of the coding and modulating processes and some very powerful error correcting strategies have been developed. These will be discussed at greater length in Part III.

Security coding.

Digital signals may be relatively easily protected against unauthorised access. The basic technique is very similar to the scrambling used for energy dispersal. The difference being that the scrambling algorithm is known only to those who have a right use it (which usually means those who have paid for it!)

DIGITAL MODULATION

Having coded our data signal, we now need to modulate a carrier in such a way as to allow the receiver to demodulate and recover the coded data efficiently. Efficient modulation makes minimum use of bandwidth while maximising the accuracy of data recovery in the presence of noise and interference.

The basic parameters of the carrier which may be modified are (i) its *amplitude* and (ii) its *phase angle*, in relation to a 'reference' unmodulated carrier. It may sometimes be more convenient to describe the carrier's phase changes as frequency *modulation* or as *phase modulation*. Remember that the two are inextricably linked since frequency is the rate of change of phase. Most modulation stems tend to be a mix of amplitude and phase angle modulation.

Amplitude modulation is a 'linear' process where the bandwidth of the modulating

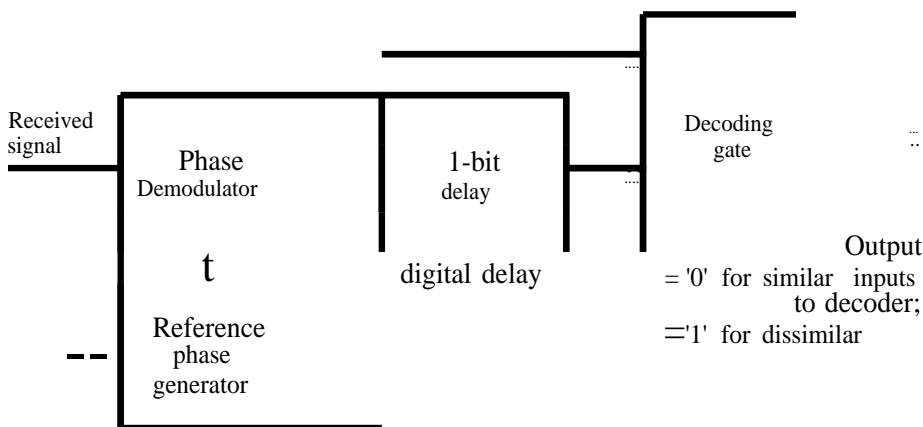

Figure 2c - *Differential decoding*

Continued on page 17

DIGITAL BROADCASTING (PART 11)

ENERGY DISPERSAL

A common requirement for digital transmission systems is to ensure that the signal energy is evenly spread over the transmitted bandwidth. This amounts to removing any strong repeating patterns from the incoming data. A self-synchronising scrambler is a very common technique for achieving this. At the transmitting end, an exclusive-or gate is used to selectively invert the incoming data. The decision to invert is dependent upon previously-transmitted data values. This information is also available at the receiving end and a similar decision can be taken as to whether the received data needs to be inverted or not.

In the example shown, the third and fifth previously-transmitted data values are used to control the inverting process. In a typical situation, a delay of sixteen or more data samples would be used. The result of the scrambling is that the transmitted data contains 'random' inversions of the input data and any strong patterns tend to get broken up.

The disadvantage of this system is that each bit in the received sequence is used a number of times to generate the output data (three times in the example). A single error in the received sequence produces a number of errors in the decoded output.

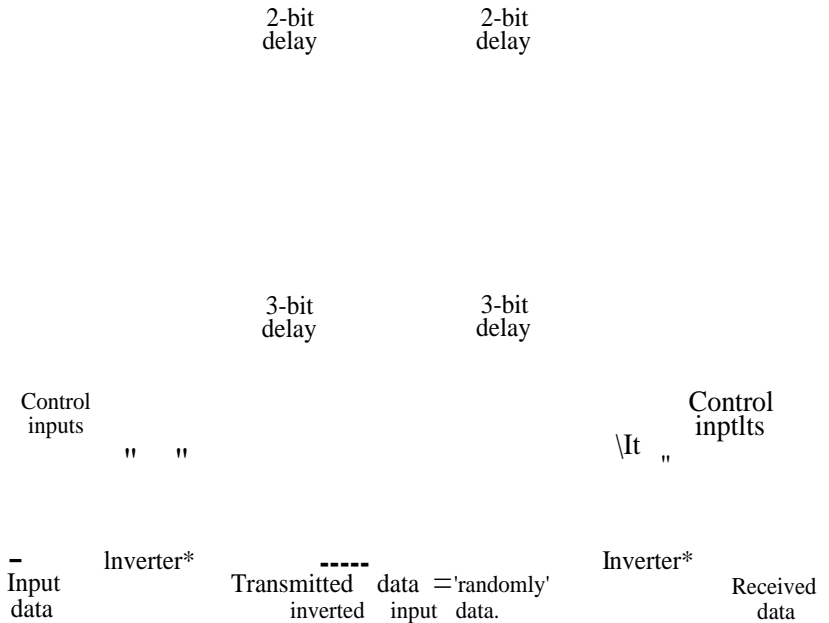

* Data is inverted only if both control inputs are the same logic polarity.

A SINGLE-ERROR CORRECTING CODE

The principle of parity checking to detect errors may be extended to allow errors to be corrected. If a number of parity checks are made but with each check covering different combinations of the data word, then cross-checking of the different parity bits would allow the error to be located. If we know where the error is, we can correct it simply by inverting the data bit.

As an example, let us assume that we are transmitting data in 7-bit words. There are seven different ways in which a single error can affect the data word (first bit errored, second bit errored, etc.). If we add to this the error-free condition, which certainly needs to be recognised, then there are eight different possibilities. We then need to allocate at least three of our data bits to carry check information (as three bits have eight unique combinations and hence could identify the eight unique possibilities). We can choose our check bits so that three different conditions are satisfied by all transmitted words:

- 1) There are an even number of ones in bits 1, 3, 5 and 7.
- 2) There are an even number of ones in bits 2, 3, 6 and 7.
- 3) There are an even number of ones in bits 4,5,6 and 7.

The receiver tests the three conditions described above with the answer '0' for a successful test (an even number of ones in the checked bits) and the answer '1' for a failed test. A number can be formed from the answers which is a binary number pointing to the

errored bit (000 is the non-errored condition). An example is shown below:

Bit number:	7654321	
	1100---	message bits.
	110	check bits.
	1 100 1 10	complete message (check bits on the right)
	1 1 0 1 1 1 0	received message (bit 4 errored).
	1 - 0 - 1 - 0	test 1, there are an even number of bits so the answer is 0.
	1 1 - - 1 1 -	test 2, again the answer is 0.
	1101---	test 3, this time there are an odd number of bits giving an answer 1.

If we now take the results of the three tests and form them into a binary number (with test 3 as the most significant) then we have 100 (or binary 4) which points to the errored bit. If we invert that bit, we then get the correct result. This particular code is known as a Hamming (7,4) single-error correcting code. The term (7,4) indicates that there are seven bits in each transmitted word of which four are message bits and the rest are check bits.

DIGITAL BROADCASTING (PART 11)

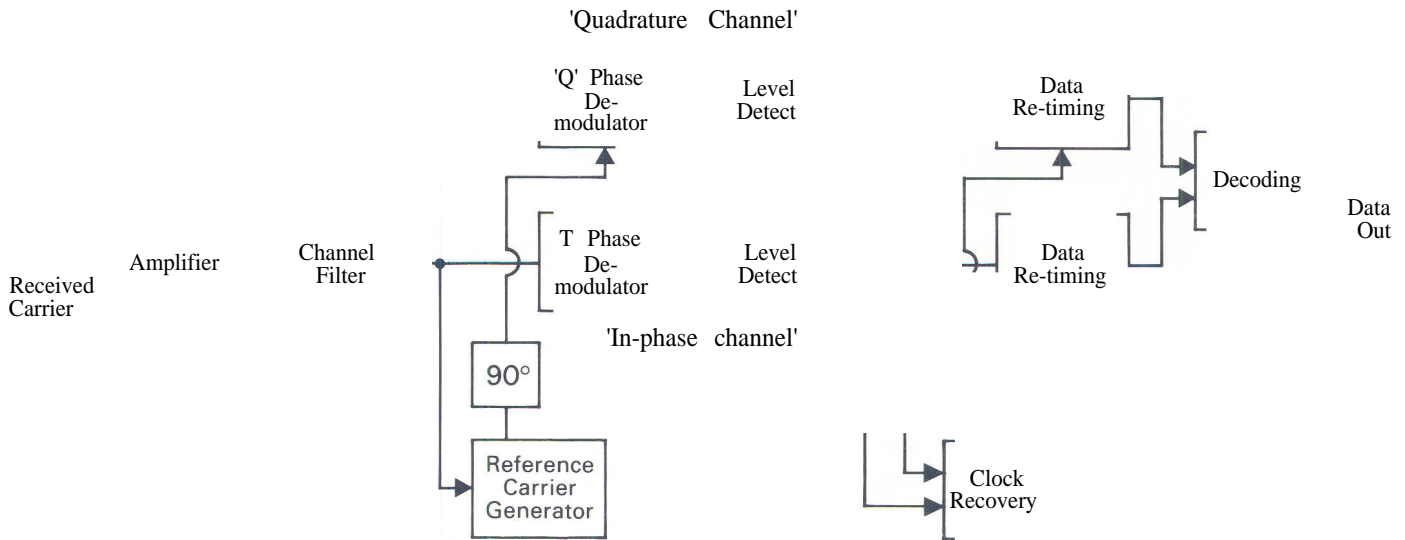

Figure 3 - Idealised digital receiver

signal is transferred directly to the carrier. It tends to result in efficient use of bandwidth but suffers a number of disadvantages. The main one is a requirement for linear power amplifiers in the transmitter.

Unlike amplitude modulation, phase modulation results in a spreading-out of the frequency spectrum of the modulating signal. In theory, at least, the energy is spread out over a significant bandwidth either side of the carrier. Filtering may be used to remove some of this energy but at the expense of introducing some amplitude modulation.

Some of the most popular modulation schemes are listed below with a brief description.

Amplitude-shift keying

This involves changing the amplitude of the carrier to carry the data. For example, a simple system could use no carrier to represent binary '0's and 100% carrier for binary '1's'. Note that the term 'keying' is commonly used to represent changes between carrier states. This is something of a misnomer since the carrier is usually moved gradually from one state to the next. Abrupt carrier-state changes imply excessive bandwidth.

Phase-shift keying (PSK)

The simplest of these systems is the one described earlier, where the carrier phase is switched between two states, separated by 180 degrees. This is binary phase-shift keying (BPSK). It has the merit of relative simplicity but is not particularly efficient in its use of bandwidth.

The carrier phase may be switched between a larger number of phase states to reduce bandwidth requirements. If, for example, we transmit two bits per carrier-phase state, then we need four states (90 degrees apart) to cope with the four possible combinations

'00', '01', '10' and '11'. This is called quaternary phase-shift keying or QPSK.

Simple QPSK signals produce large amounts of amplitude modulation after filtering: various derivatives of QPSK have been developed which produce lower amounts of a.m. for a given amount of filtering. However, more complex systems - based on more carrier phase states - are now coming into use; for example, 8-PSK and 16-PSK with three and four bits per phase state. These minimise bandwidth at the expense of more susceptibility to noise. This can be overcome either by raising the transmitted power level, which may not always be possible, or through the use of error-correcting codes to recover some of the lost performance.

Frequency-shift keying (FSK)

In this case the frequency of the carrier is switched between two or more discrete frequencies. The most popular form of this is minimum-shift keying (MSK), which is sometimes called fast frequency-shift keying (FFSK). Here, the carrier is switched between two frequencies chosen so that the carrier phase advances (or retards) by 90 degrees over a bit period.

RECEPTION OF DIGITAL TRANSMISSIONS

The digital receiver must recover the original data from the modulated signal. The received signal will be at a relatively low signal level and will be degraded by unwanted signals and other degradations introduced by the transmission path. The principal unwanted signal is usually thermal noise, introduced at the receiver's front-end, but there may also be others such as interference from other signals. The transmission channel may also distort the signal, due to frequency response impairments or non-linear impairments such

as amplitude-to-frequency conversion. All these deficiencies tend to lead to a loss of the original ideal phase or amplitude states.

After amplification and filtering (which removes any unwanted signals that are outside the bandwidth needed to accommodate the wanted signal), the incoming signal is demodulated. This is usually achieved by demodulating the data into two quadrature components of the modulated signal. These are called the I (in-phase) and Q (quadrature) signals. Two phases of 'reference' carrier need to be regenerated in order to achieve this - see Figure 3.

The I and Q signals are an analogue representation of the carrier phase. They may be

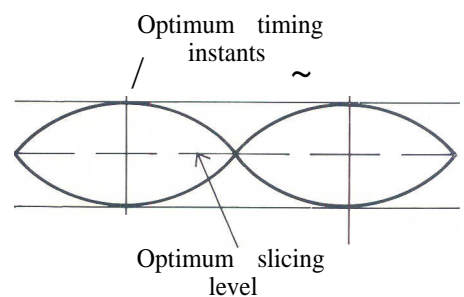

Figure 4a - 'Ideal' data eye

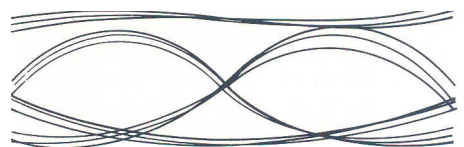

Figure 4b - Received eye degraded by transmission pull distortions.

DIGITAL BROADCASTING (PART 11)

examined and compared with 'ideal' I and Q signals to provide a measure of the quality of the received signal. These are generally referred to as 'eye' diagrams. Figure 4a shows an ideal eye with optimum sampling points for level and timing indicated. The sampling is the process by which the binary data is generated from the demodulated signal. Figure 4b shows a distorted eye showing that the operating margin of the system has been degraded by transmission path distortions.

SOME DISADVANTAGES

It would not be right to leave the topic of digital transmission pretending that it is the universal panacea. Some of its disadvantages must also be pointed out.

Digital systems are characterised by a very rapid onset of failure. Provided that the system's degradations are below a certain threshold, then all is well and the data is perfectly recovered. However if the noise increases above this threshold, then performance degrades rapidly.

Uncorrected errors in digital audio systems tend to produce objectionable clicks and pops. More severe errors can cause loss of synchronism in the receiver at which point the system is liable to produce something in the nature of a loud raspberry.

Another disadvantage is the delay which may be introduced by the coding system. In general, the more complex the system the greater the delay. Delays of tens of milliseconds and more are fairly easily accumulated. However, the delay may not always be perceived as a disadvantage. One senior IBM executive, when contemplating the transfer of their inter-office telephone system to a satellite with about a quarter second delay, is known to have considered that this would lead to politer telephone conversations between IBM staff!

AN EXAMPLE OF A DIGITAL BROADCASTING SYSTEM

To illustrate some of the points made above, I shall use the RDS system. For those who do not know it, this is a sub-carrier at 57kHz added to FM transmissions. The nature of the data is not relevant to this article. Suffice to say that it is intended to assist with receiver tuning.

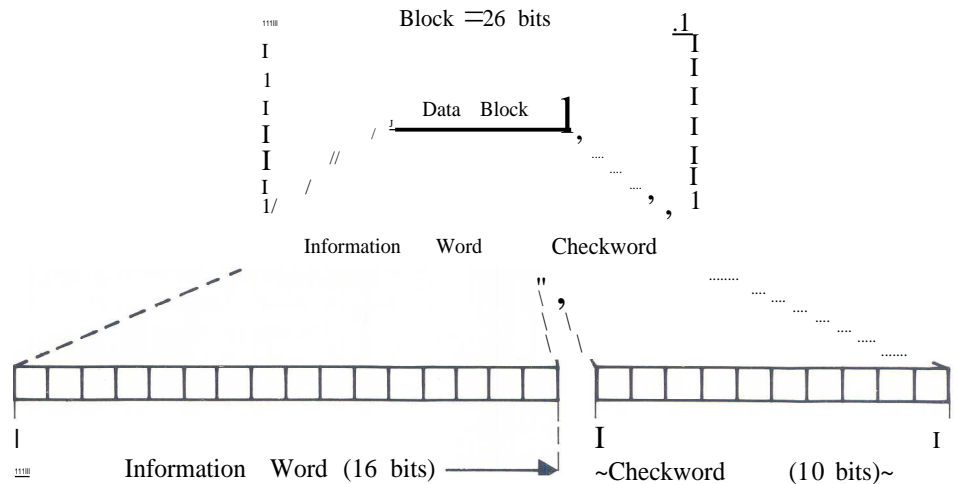

Figure 5a - RDS Data Block structure

RDS information is packaged into 16-bit words. Ten check digits are added to each 16-bit word to form a 26-bit block (Fig 5a). In each block, the check digits allow for:

- Detection of all single and double bit errors.
- Detection of all bursts of errors of 10 bits or less.
- Correction of all bursts of errors of 5 bits or less.
- A high probability of detection of error bursts longer than 10 bits.

The check digits also serve to provide block synchronisation in the receiver. The check digits are chosen so that, when the receiver is out of synchronisation, there is a high probability of receiving 26-bit blocks which are not normally transmitted, ie invalid combinations of information and check digits. In normal synchronism, of course, there should be a high probability of receiving the correct combinations. Adequate energy dispersal is provided by the rather versatile check digits and no additional energy dispersal is provided. Differential decoding is included to prevent the problem of data inversion, discussed earlier.

The RDS system uses a 57kHz sub-carrier but has to co-exist with another system which also uses a 57kHz sub-carrier (the German ARI system). There must be little or no energy at the carrier frequency to avoid mutual interference. This is achieved using suppressed carrier amplitude modulation for

the data. Some pre-coding is also used to minimise the low-frequency energy in the data. Each bit from the differential decoder is coded into two bits (at twice the bit-rate). A '0' is coded as '01' and a '1' as '10'. This has the effect of re-distributing the energy in the datastream from low to high frequencies (long strings of '0's' or '1's' cannot occur) and is known as bi-phase signalling. Figure 5b is a block diagram of an RDS coder and modulator.

At the RDS receiver (Fig 6), the data channel is filtered to remove out-of-band signals and the RDS carrier is synchronously demodulated using a locally regenerated carrier. After further filtering, the data is sliced and latched by a locally-generated clock to re-establish binary data. This is followed by a differential decoder and some data processing which establishes block synchronism by searching for a high incidence of correct 26-bit combinations. After correcting errors and discarding the check digits, the received 16-bit information words are available for processing by the receiver.

Rhys Lewis
Design Group, D&ED

In the concluding part of this series, Tim Shelton of Research Department will look at recent practice in improving error handling and minimising bandwidth requirements. He will also be looking at what the future of digital broadcasting holds.

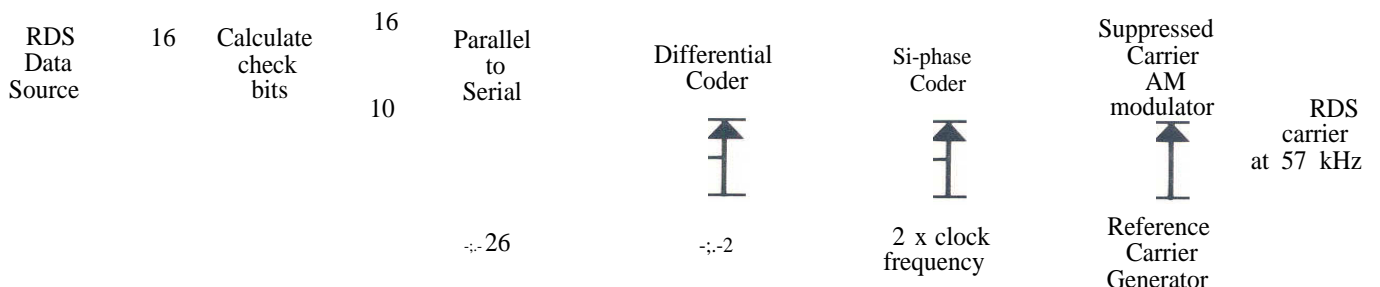

Figure 5b - RDS carrier generator (simplified)

DIGITAL BROADCASTING (PART 11)

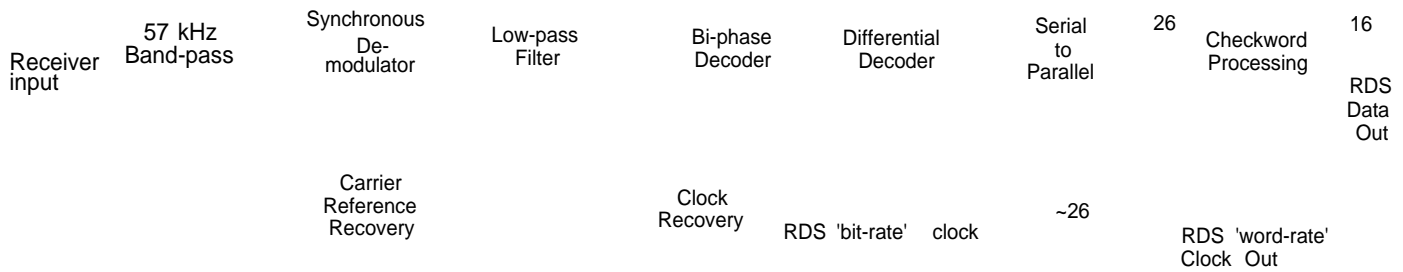

Figure 6 - RDS Receiver (simplified)

FURTHER READING

'Basics of Communications and Coding', William G Chambers, Oxford Science Publications.

'Specifications of the Radio Data System RDS for VHF /FM Sound Broadcasting', EBU Document 3244-E.

'Digital Communications by Satellite', Bhargava et al, Wiley.

In the concluding part of this series, Tim Shelton of Research Department will look at recent practice in improving error handling and minimising bandwidth requirements. He will also be looking at what the future of digital broadcasting holds.

BELFAST Further Post Production Facilities

The second phase in the development of Post Production facilities at Belfast BH has now been completed. The old first floor Newsroom, ST2 area, has been developed into a multistandard Dubbing Suite which can, for the purposes of description, be divided into four parts:

1. Sound Dubbing Theatre Control Room
2. Sound Studio
3. Preparation Room, with 12-channel Amek BC 11 desk
4. Transfer, Apparatus and Machine Room, with Amek transfer desk

The spacious dubbing theatre is equipped with a 28-channel fully-modified and automated Calrec mixing desk, an Amek BC 11 12-channel effects desk and the usual complement of grams, tapes and COs. An important additional facility is an 8-input/8-output AMS Audiophile, which can easily be moved and utilised in other parts of the suite. The small sound studio is accessed from this theatre.

The core of this dubbing facility consists of four Albrecht Sepmags and a 16mm



The Apparatus and Transfer area.

projector driven by the Albrecht Universal Control System. The latter can also be used to synchronise other equipment including Betacam SP vt machines and 24-track Otari audio machines. With a Quantel Paintbox recently installed in the Graphics Area, the NI Region can now be boastful of its excellent Post Production facilities.

FWO Bauch was the main contractor in this latest phase of development and, as for Phase I (the three machine VT Edit and Graphics Suite described in Eng Inf No 35), the P&ID Tel project leader was Keith Spooner.

Fred Wylie
MCES, Belfast

BRISTOL Design Award for ACED

The new Post-Production building at Bristol has been commended by the Stone Federation in its 1989 Design Awards for Natural Stone. The building was designed 'in-house' by the Architectural and Civil Engineering Department (ACED). It consists of some 6500 sq. metres of floor area and accommodates cutting, editing and video-tape suites, offices, a restaurant and a reception area, occupying a total of four floors.

Planning the new development was influenced by three main concerns:-

1. The domestic scale of the Victorian Venetian-style villas which made up the main accommodation at the Bristol Network Production Centre.
2. The need to respond to the tradition of stone building in the surrounding areas of Bristol.
3. The problem of expressing a high-tech function, using traditional forms and materials.

Overall, the new building is much larger than its neighbours but the scale has been controlled by breaking the development down into three 'villas' which reflect the scale and form of the neighbouring pairs of Victorian semi-D's. The use of pitched roofs allows an extra floor of accommodation without the associated bulk.

As with the houses in the street, each villa is slightly different from its neighbour. In the BBC's case, the three blocks develop from full stone facades to fully-glazed facades as you progress around the site. This progression, or metamorphosis, peels away the traditional facade to reveal a more appropriate high-tech feel at the back of the site, responding to its broadcasting function.

The entrance portico, placed between the two front villas, began as a canopy leading to a doorway through a rusticated stone wall. This has been developed into its present form of open stone banding between Doric columns,

allowing light into the entrance area. The first floor colonnade creates a visual screen to the glazed areas behind and adds presence to what is now the main front door to the site.

The careful detailing and the use of natural materials (for the main facades and the details) ensures a comfortable relationship with the street and should ensure that the building weathers and ages gracefully.

The construction is a reinforced concrete frame. It is clad on the front elevation with a cavity wall of lightweight blockwork, mineral wool cavity fill and an outer skin of Bath stone panels with Portland stone plasters, parapets and details. The rear elevation is a proprietary window-wall system with natural stone, reconstituted stone and aluminium margins.

Alan James
Associate Architect, ACED



The two front villas and the entrance portico.