

Appendix B
Solar Stirling Engine

TABLE OF CONTENTS

APPENDIX B SOLAR STIRLING ENGINE		Page
1.0	HISTORY OF THE STIRLING ENGINE.....	B-1
2.0	TODAY	B-2
3.0	SOLAR STIRLING ENGINE	B-4
4.0	HEAT AND MASS BALANCE.....	B-10

LIST OF TABLES & FIGURES

Figure B-1 Original Engine Developed In 1816.....	B-1
Figure B-2 Automotive Stirling Engine.....	B-2
Figure B-3 Solar Stirling Engine	B-5
Figure B-4 Photograph of the Solar Receiver.....	B-6
Figure B-5A Power Conversion Unit (PCU) View A	B-7
Figure B-5B Power Conversion Unit (PCU) View B.....	B-8
Figure B-5C Power Conversion Unit (PCU) View C.....	B-9
Figure B-6 Schematic of SunCatcher In Operation	B-11
Figure B-7 SunCatcher Comparison To Other Renewable Technology	B-12

1.0 HISTORY OF THE STIRLING ENGINE

On September 27, 1816, Robert Stirling applied for a patent for his Economizer at the Chancery in Edinburgh, Scotland. By trade, Robert Stirling was actually a minister in the Church of Scotland and he continued to give services until he was eighty-six years old. But, in his spare time, he built heat engines in his home workshop. Lord Kelvin, who is best known for his work in the field of electricity, especially submarine telegraphy, used one of the working models during some of his university classes.

In 1850, Professor McQuorne Rankine first explained the simple and elegant dynamics of the engine. Approximately one hundred years later, Rolf Meijer coined the term “Stirling engine” in order to describe all types of closed cycle regenerative gas engines.

**FIGURE B-1
ORIGINAL ENGINE DEVELOPED IN 1816**

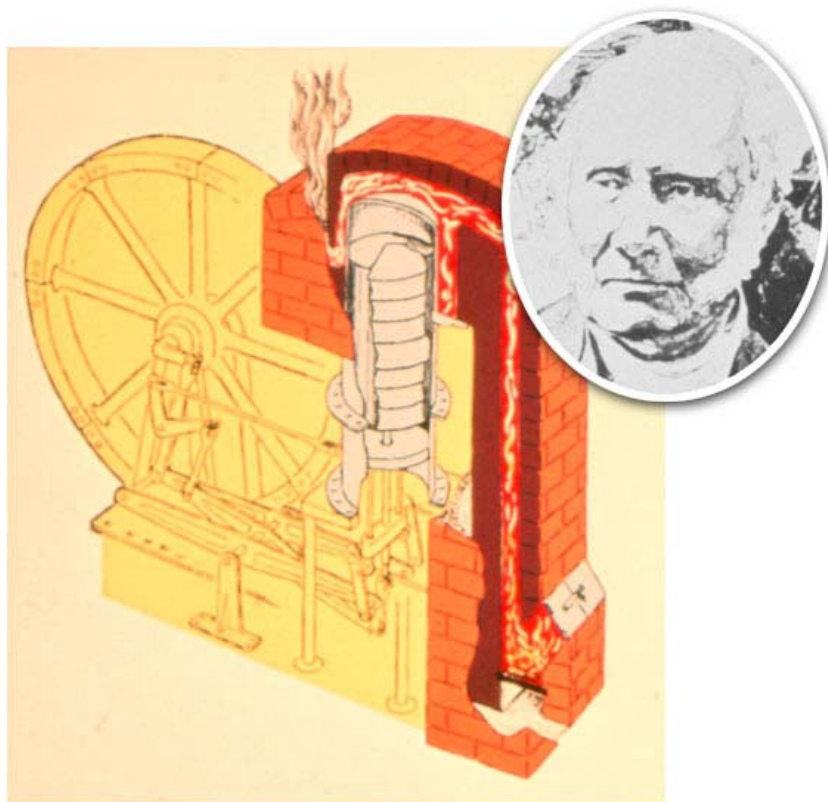

2.0 TODAY

Today, Stirling engines are used in some very specialized applications, like in submarines or auxiliary power generators, where quiet operation is important. Stirling engines are unique heat engines because their theoretical efficiency is nearly equal to their theoretical maximum efficiency, known as the Carnot Cycle efficiency. Stirling engines are powered by the expansion of a gas when heated, followed by the compression of the gas when cooled. The Stirling engine contains a fixed amount of gas that is transferred back and forth between a "cold" end and a "hot" end. The "displacer piston" moves the gas between the two ends and the "power piston" is driven due to the change in the internal volume as the gas expands and contracts. A typical automotive application of the Stirling engine is illustrated in Figure B-2.

FIGURE B-2
AUTOMOTIVE STIRLING ENGINE

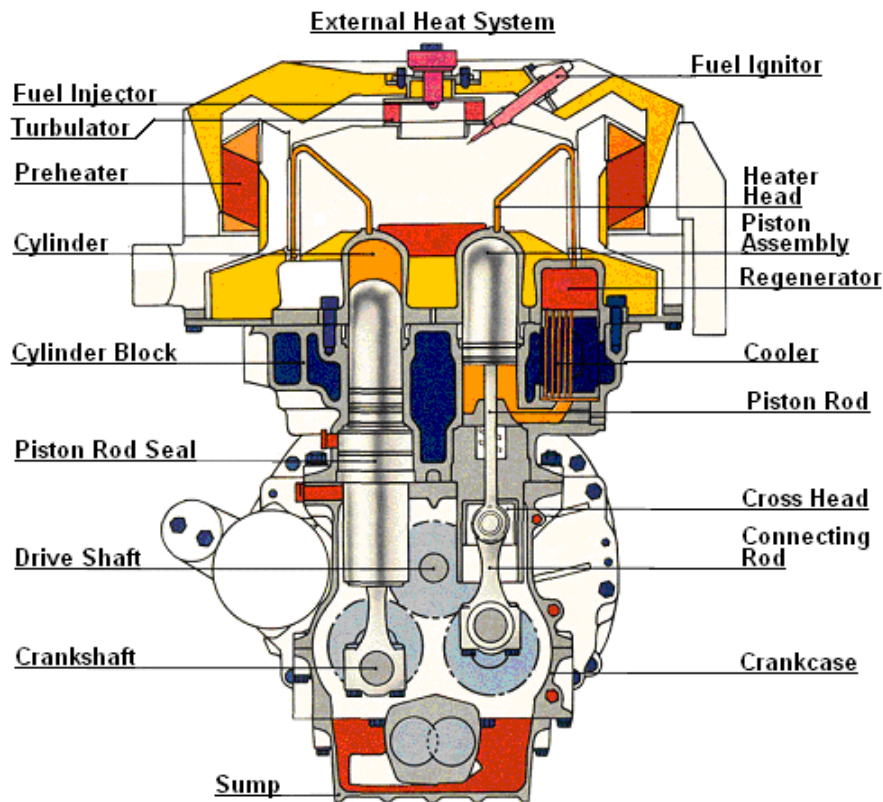

The gases used inside a Stirling engine never leaves the engine. There are no exhaust valves in Stirling engines. There are no explosions or combustion. Because of this, Stirling engines are very quiet.

The Stirling cycle uses an external heat source, which could be anything from gasoline solar energy or the heat produced by decaying plants. No combustion takes place inside the cylinders of the engine.

3.0 SOLAR STIRLING ENGINE

The SunCatcher Stirling technology is well beyond the research and development stage with more than 20 years of recorded operating history. The equipment has more than 25,000 hours of on-sun time. Since 1984, the Company's solar dish Stirling equipment has held the world's efficiency record for converting solar energy into grid-quality electricity. SES continues to work with the U.S. Department of Energy and Sun-Labs (NREL and Sandia National Laboratories) to endurance test and commercializes the SES SunCatcher system.

The SunCatcher Power Conversion Unit (PCU) uses a Kockums kinematics Stirling engine design. Kockums is the world's leader in kinematics Stirling engines. Kockums has invested significant development into the design, efficiency and reliability of this type of Stirling engine since purchasing the technology in 1970. The Kockums kinematics Stirling engine is a 380 cubic centimeters displacement, four-cylinder reciprocating engine receiving compressed and heated hydrogen gas from the Solar Receiver to drive the Stirling cycle.

The Stirling engine's cylinder block, as shown in the Figure B-3, Stirling Engine Internal Components, incorporates four sealed cylinder assemblies (pistons, piston rod and connecting rods) along with coolers, regenerators and heater heads.

FIGURE B-3
SOLAR STIRLING ENGINE

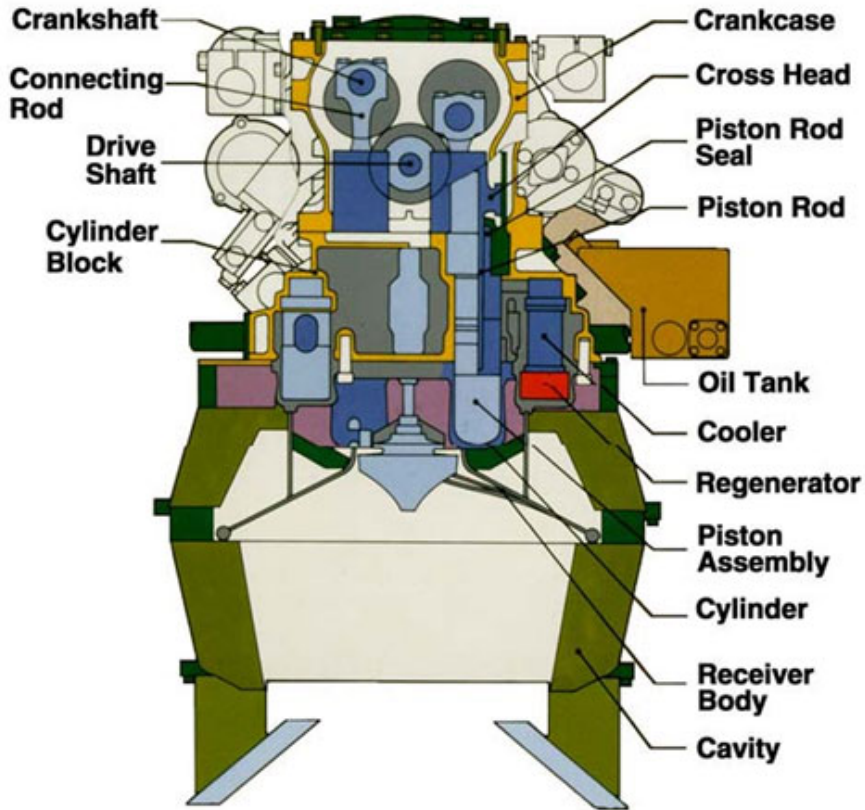

Changes to the SunCatcher Stirling engine have been primarily with the addition of the Solar Receiver. The receiver consists of an insulated cavity with an aperture to allow the concentrated sunlight to enter. Within the cavity are four heater heads. Each heater head is a tube network for one quadrant of the engine. The metal tubes along with the engine form a closed system that contains the working fluid, hydrogen gas. Figure B-4 is a photograph of the Solar Receiver.

**FIGURE B-4
PHOTOGRAPH OF THE SOLAR RECEIVER**

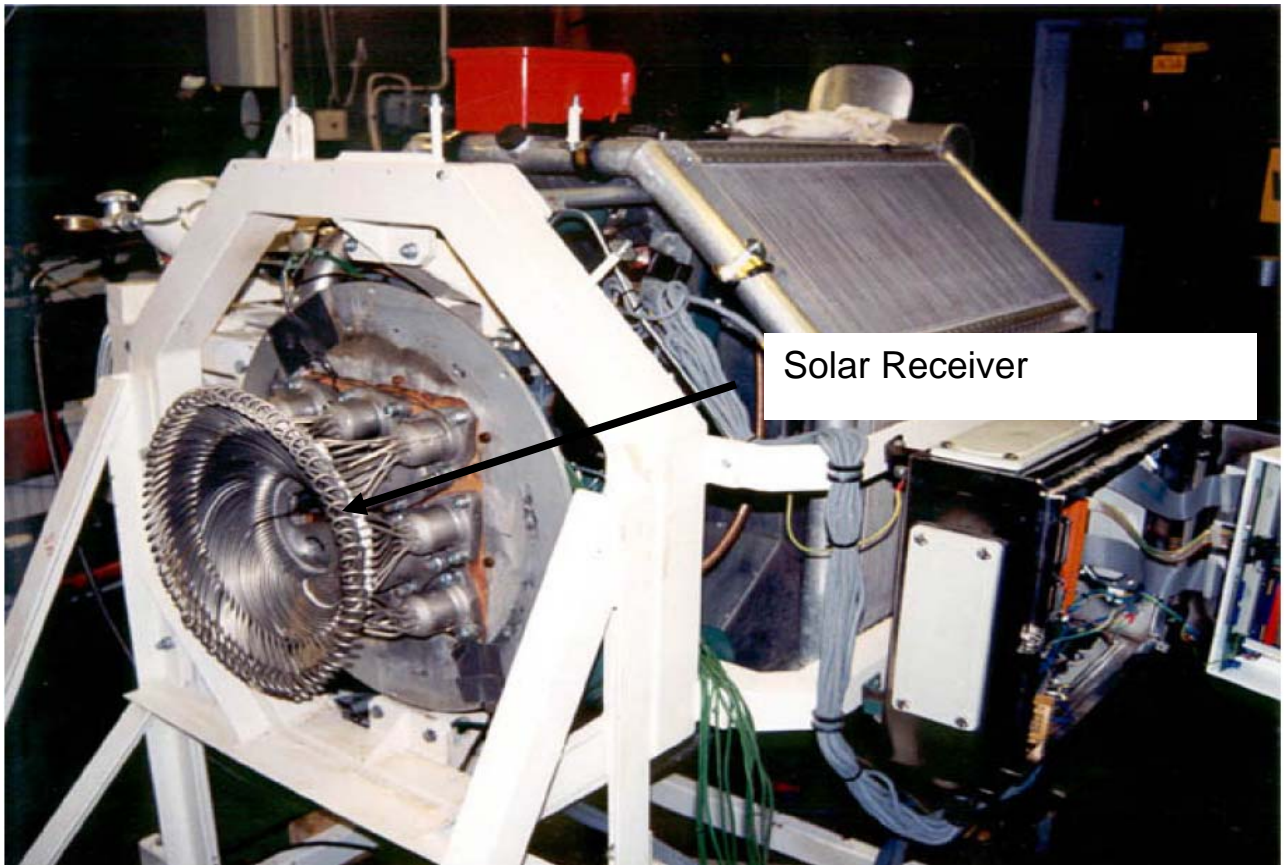

Concentrated solar energy enters an aperture in the slew shield that protects the PCU from focused solar energy and focuses on the Solar Receiver. The solar energy heats the hydrogen gas contained in the heater heads to a maximum temperature of approximately 600C. The location of the Solar Receiver is illustrated in the block diagram in the Figure B-5A.

FIGURE B-5A
POWER CONVERSION UNIT (PCU) VIEW A

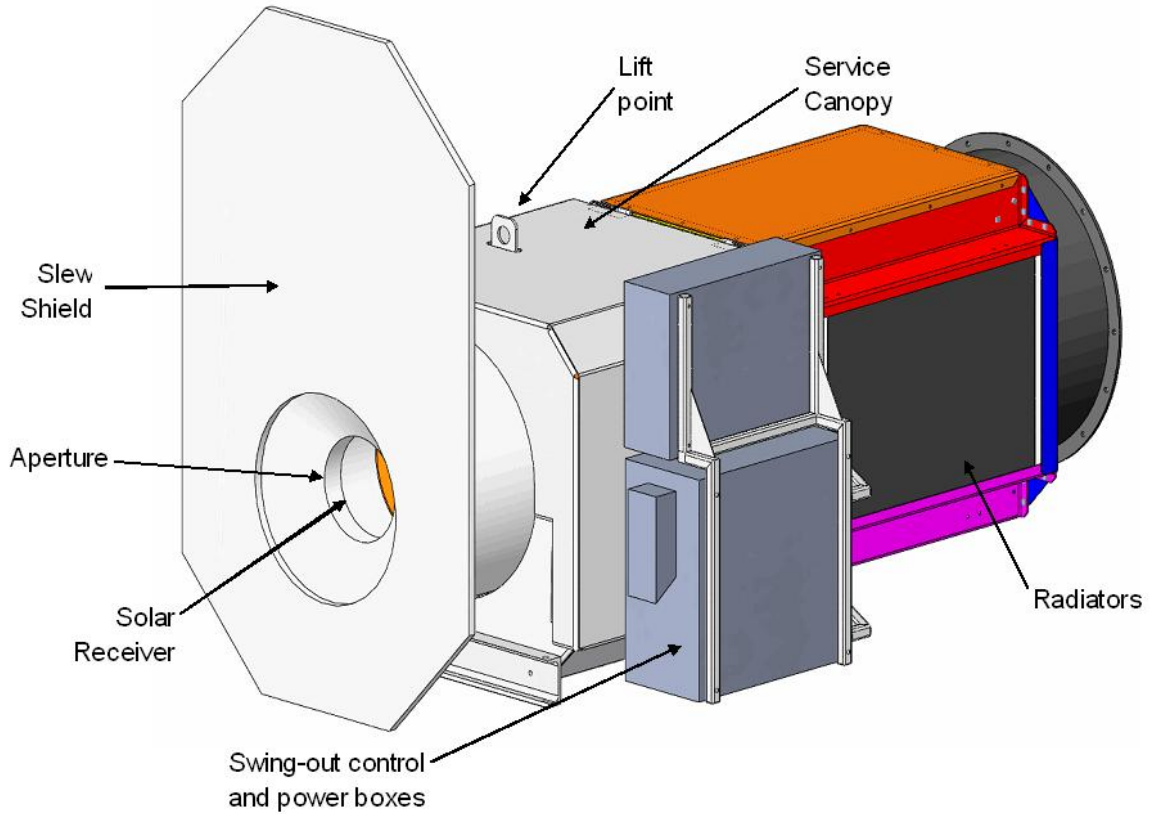

Inside the Stirling engine's cylinders, the pressure from the expansion pushes the piston assembly toward the crankshaft while at the same time gas from an adjacent chamber that has been cooled by a radiator system is compressed for another cycle of the Stirling cycle. The difference between work supplied (expansion) and work performed (compression) provides for a net output that is converted to mechanical motion. This mechanical motion produces an efficient rpm that drives an electrical generator. Figure B-5B and Figure B-5C illustrate the location of the Stirling engine and the induction motor generator in the PCU arrangement.

FIGURE B-5B
POWER CONVERSION UNIT (PCU) VIEW B

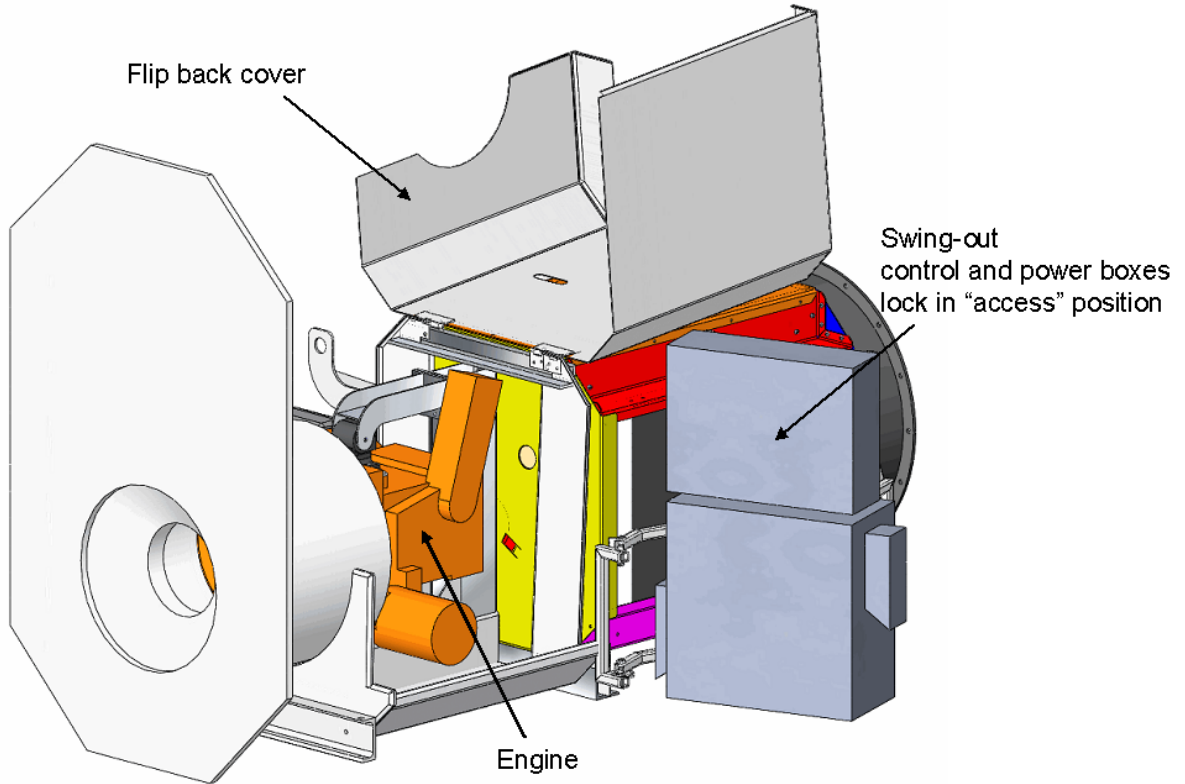
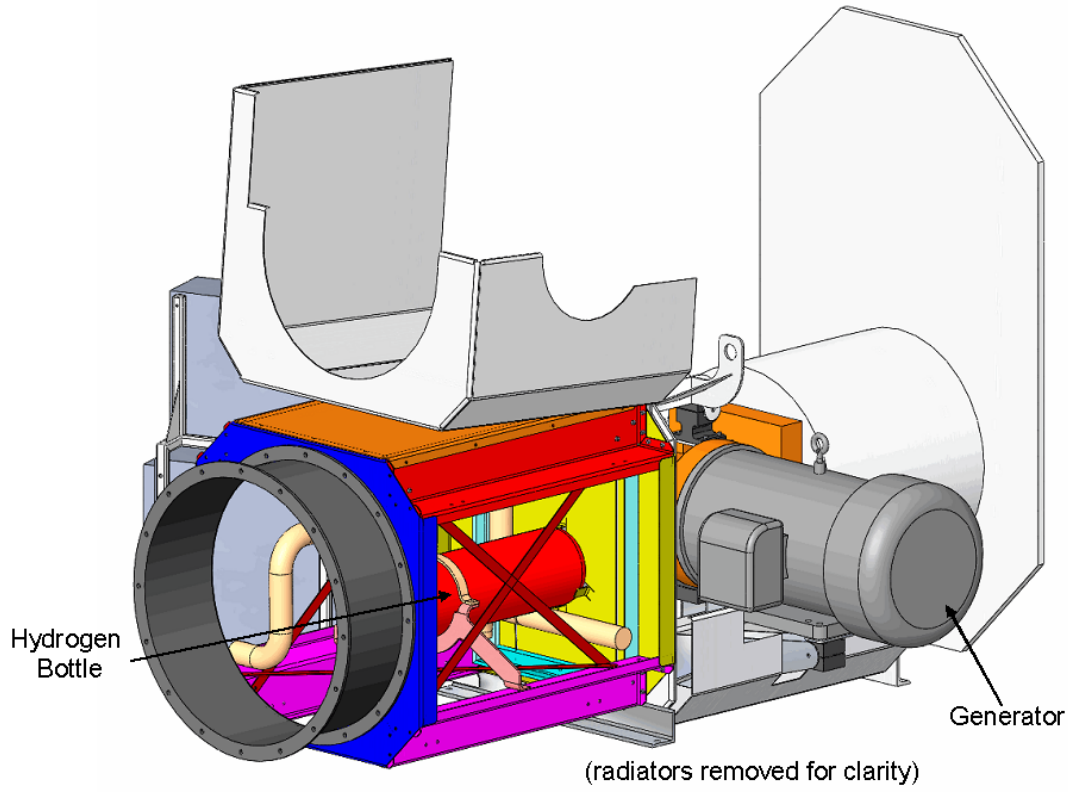

FIGURE B-5C
POWER CONVERSION UNIT (PCU) VIEW C



4.0 HEAT AND MASS BALANCE

The SunCatcher produces no combustion products or air emissions since the Stirling engine operates with solar energy heat input via the external heat exchanger, the Solar Receiver. This system is a closed-loop cycle using hydrogen as the working fluid inside the engine. A small amount of the hydrogen working fluid does leak by the rod seals and is lost to the atmosphere. This poses no health, safety, or environmental effects.

The hydrogen gas is cooled by a standard glycol-water radiator system similar to an automobile's radiator system. In addition, the hydrogen gas is continually recycled within the engine during the power cycle. The conversion process does not consume water as is required by most thermal powered generating systems. The only water consumed by the SunCatcher is for washing of the mirrors to remove accumulated dust. As a result, the SunCatcher generating system consumes neither water nor fuel in the generation of electricity.

Figure B-6 illustrates the conversion process of solar energy into electricity by the SunCatcher generating system. At peak operating conditions, the SunCatcher receives solar isolation at approximately 1,000 watts per square meter and converts this solar energy into 25kW at 575VAC 60Hz of grid-quality electricity when operating with full solar input. This solar energy would normally fall on the site. A portion of the solar energy is extracted by the SunCatcher to generate electrical power and the remainder is radiated or absorbed into the local environment.

The SunCatcher is supported by a glass mirror facet. Provide approximately 90 to 100 square meters of this mirror set reflects solar energy and focuses the beam of light in to the Solar Receiver area. The mirrors concentrate solar energy onto the external solar receiver of the PCU heating contained hydrogen gas. As the gases are heated up, this causes the gas to expand into the cylinders which powers the Stirling cycle engine. A Dish Positioning Control System controls azimuth and elevation drives motors for tracking the sun to optimize the focus of the solar energy onto the Solar Receiver.

Nominal Stirling engine outlet temperature from the cooling radiator is just above ambient temperature. The logic of the radiator fan is based upon the coolant temperature on the hot side of the engine. Fan low speed comes on when the engine outlet temperature gets above ambient. Fan high speed comes on when the engine outlet temperature reaches twice ambient. Upon any fault, the dish control system takes the SunCatcher off sun thus shutting down the PCU and automatically moves off sun.

Solar energy is focused on the Solar Receiver that is converted to 25kW of electricity for a peak conversion efficiency of approximately 31.25 percent. SES holds the world record of

31.25% efficiency for solar insolation to grid commercial power. This is illustrated in the Figure B-7.

The remaining solar energy is lost through:

- Mirror reflection losses radiated to atmosphere.
- Absorption losses from the Solar Receiver radiated back to atmosphere.
- Radiated heat loss to atmosphere from the PCU radiator heat discharge due to hydrogen gas cooling required for the Stirling cycle.

These losses would be absorbed by the area occupied by SunCatcher. This solar energy would normally be absorbed naturally without the SunCatcher installations. In essence, the SunCatcher is converting a portion of solar energy into electricity, which would otherwise being absorbed in the area. The net effect is a small reduction in the transfer of heat from the sun to the local environment into electricity.

FIGURE B-6
SCHEMATIC OF SUNCATCHER IN OPERATION

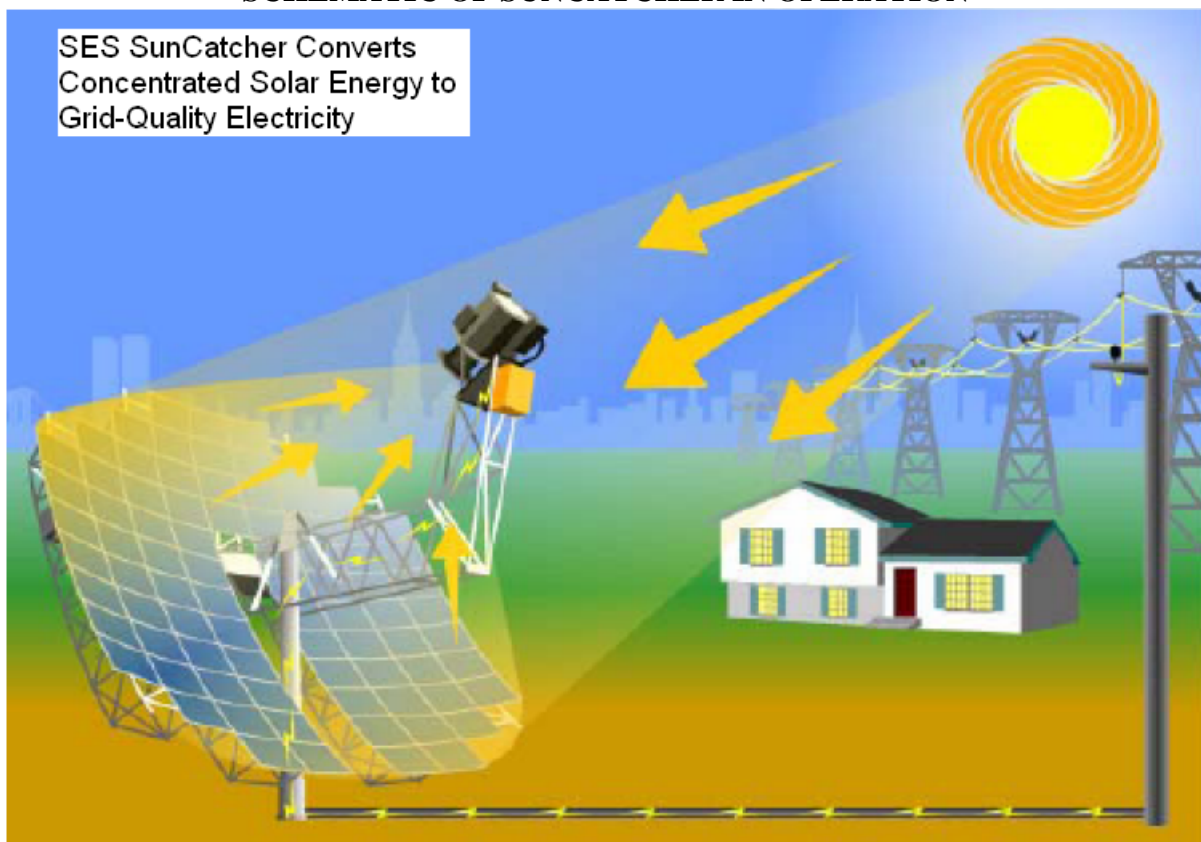

FIGURE B-7
SUNCATCHER COMPARISON TO OTHER RENEWABLE TECHNOLOGY
SunCatcher - The Next Generation in Renewable Energy

Attribute ¹	Solar Technologies				Other Renewables	
	SunCatcher	Rooftop PV	Parabolic Trough	Power Tower	Wind	Geothermal
Time of Day Production	Peak	Peak	Peak	Peak	Variable	Baseload
Fuel Needs	None	None	Natural Gas	None	None	None
Resource Abundance ²	Good	Good	Good	Good	Fair	Not Common
Predictability	Good	Good	Good	Good	Intermittent	Good
Reliability	Good	Good	Good	Fair	Good	Good
Peak Efficiency ³	29.4%	9 - 13%	15%	13 - 22%	N/A	N/A
Annual Efficiency ⁴	22 - 24%	< 10%	10.6 - 14%	7.6 - 13.7%	N/A	N/A

¹ SES resource assessments

² Resource abundance characterizations based on Southwest U.S.

³ SES management assessments.

⁴ Ren21 Renewables 2006 Global Status Report

SunCatcher is the best solution for utility-scale, peak renewable power