

TOPOGRAPHICAL BIBLIOGRAPHY OF
ANCIENT EGYPTIAN HIEROGLYPHIC
TEXTS, RELIEFS, AND PAINTINGS

III² MEMPHIS

Part 2. Şaqqâra to Dahshûr

BY

THE LATE BERTHA PORTER

AND

ROSALIND L. B. MOSS

B.Sc. and Hon. D.Litt. (Oxon.), F.S.A.

Assisted by

ETHEL W. BURNEY

SECOND EDITION

REVISED AND AUGMENTED

BY

PHDR. JAROMÍR MÁLEK

GRIFFITH INSTITUTE
ASHMOLEAN MUSEUM, OXFORD

1981

© *Griffith Institute, Ashmolean Museum, Oxford, 1981*

Part II ISBN 0 9000416 238

*Printed in Great Britain
at the University Press, Oxford
by Eric Buckley
Printer to the University*

CONTENTS

| | |
|--|-------|
| Introduction | ix |
| List of Plans | xiii |
| List of Sources of Plans | xv |
| List of Abbreviations. I. Publications | xvii |
| II. Unpublished sources | xxxii |
| Note to Readers | xxxv |

PYRAMID-FIELD OF ŞAQQĀRA

I. PYRAMIDS

| | |
|---|-----|
| A. Pyramid-complex of Teti | 393 |
| Pyramid-enclosure of Iput I | 396 |
| Pyramid-enclosure of Khuit | 397 |
| B. Pyramid-complex of Userkaf | 397 |
| C. Step pyramid enclosure of Neterikhet (Zoser) | 399 |
| D. Step pyramid enclosure of Sekhemkhet | 415 |
| E. 'Great Enclosure' | 417 |
| F. Pyramid-complex of Unis | 417 |
| G. Pyramid-complex of Pepy I | 422 |
| H. Pyramid-complex of Isesi | 424 |
| Pyramid-enclosure probably of wife of Isesi | 424 |
| I. Pyramid-complex of Merenrē' I | 425 |
| J. Pyramid of K̄akarē' Ibi | 425 |
| K. Pyramid-complex of Pepy II | 425 |
| Pyramid-enclosure of Neit | 431 |
| Pyramid-enclosure of Iput II | 432 |
| Pyramid-enclosure of Wezebtan | 432 |
| L. Burial-complex of Shepseskaf | 433 |
| M. Pyramid-enclosure of Userkarē' Khenzer | 434 |
| N. Pyramid-enclosure of Dynasty XIII | 435 |

II. NECROPOLIS

| | |
|--|-----|
| A. North of the Step Pyramid | |
| Early Dynastic cemetery west of village of Abûşîr | 435 |
| Early Dynastic cemetery north and north-west of the Serapeum | 436 |
| Early Dynastic and Old Kingdom tombs S 2146-3518 | 436 |
| Old Kingdom tombs Nos. 1-88 of Mariette | 448 |
| Other numbered Old Kingdom tombs | 490 |

| | |
|---|-----|
| Unnumbered Early Dynastic and Old Kingdom tombs | 499 |
| Late Period, Ptolemaic and Roman tombs | 503 |
| Finds | 505 |
| B. Around Teti Pyramid | |
| North | 508 |
| East and South-east | 558 |
| West and South-west | 565 |
| Firth Excavation | 566 |
| C. East of the Step Pyramid | 575 |
| D. In the Step Pyramid enclosure | 592 |
| E. West of the Step Pyramid | 593 |
| F. Around the pyramid-complex of Unis | 613 |
| G. Between the Monastery of Apa Jeremias and the enclosure of Sekhemkhet | 653 |
| H. Around pyramids of Pepy I, Merenrē' I, and Isesi | 671 |
| I. Around pyramids of Ibi and Pepy II, and Maṣṣabet Fara'ûn | 674 |
| J. Tombs of position unknown | |
| Old Kingdom | 689 |
| Middle Kingdom | 700 |
| New Kingdom | 701 |
| Late and Ptolemaic Periods | 718 |
| K. Objects from tombs | 720 |
| III. SACRED ANIMAL COMPLEXES | |
| A. Eastern Group | 777 |
| B. Western Group with the Serapeum | 778 |
| C. Northern Group | 820 |
| IV. MISCELLANEOUS | 827 |
| EL-'AZÎZÎYA | 830 |
| MÎT RAHÎNA | |
| NORTHERN ENCLOSURE | 830 |
| PTAḤ ENCLOSURE WITH DEPENDENCIES | |
| Temple of Ptaḥ | 831 |
| Subsidiary buildings and monuments | |
| A. Chapel of Amenophis III | 840 |
| B. Chapel of Amasis | 840 |
| C. Colossus of Ramesses II | 840 |
| D. Stela of Apries | 840 |

CONTENTS

vii

| | |
|---|-----|
| E. Colossal Alabaster Sphinx | 841 |
| F. Hathor-column capital | 841 |
| G. Embalming House of Apis-bulls | 841 |
| H. Chapel of Sabacon | 842 |
| I. Temple of Tuthmosis IV | 842 |
| J. Chapel of Sethos I | 843 |
| K. Temple of Ramesses II | 843 |
| L. Temple of Ramesses II | 845 |
| M. Tombs of High Priests of Memphis of Dynasty XXII | 846 |
| Finds from Ptaḥ Enclosure and Dependencies | 847 |
| KÔM EL-NAWA | 851 |
| KÔM EL-ARBA'ÎN | 851 |
| KÔM EL-FAKHRY | 852 |
| KÔM EL-RABÎ'A | 852 |
| KÔM EL-QAL'A | 854 |
| MISCELLANEOUS FROM MÎT RAHÎNA | 863 |

EL-BADRASHEIN

875

PYRAMID-FIELD OF DAHSHÛR

| | |
|---|-----|
| I. PYRAMIDS | |
| A. Northern pyramid-complex of Snefru | 876 |
| B. Southern pyramid-complex of Snefru | 877 |
| C. Pyramid-complex of Sesostris III | 882 |
| D. Pyramid-complex of Amenemḥēt II | 885 |
| E. Pyramid-enclosure probably of Dynasty XIII | 887 |
| F. Pyramid-complex of Amenemḥēt III | 887 |
| Tomb of King Awibrē' I Ḥor | 888 |
| Tomb of Nubḥetepti-khred | 889 |
| G and H. Pyramids probably of Dynasty XIII | 890 |
| I. Pyramid of Ameny-Ḳemau | 890 |
| II. NECROPOLIS | |
| A. East of the northern pyramid of Snefru | 890 |
| B. East of the southern pyramid of Snefru | 894 |
| C. North of the enclosure of Sesostris III | 896 |
| D. South of the enclosure of Amenemḥēt II | 898 |

| | |
|--------------------|-----|
| III. MISCELLANEOUS | 898 |
|--------------------|-----|

| | |
|---------|-----|
| ADDENDA | 901 |
|---------|-----|

APPENDIXES

| | |
|---|-----|
| A. Selected scenes in Old Kingdom tombs | 903 |
| B. Selected Old Kingdom texts | 907 |
| C. Pyramids | 909 |
| D. Numbered Şaqqâra tombs | 910 |
| E. Viziers | 914 |
| F. High Priests of Memphis | 916 |
| G. Old Kingdom and First Intermediate Period titles | 918 |
| H. Apis-bulls | 940 |
| I. Apis-stelae in the Louvre | 941 |

INDEXES

| | |
|-----------------------|-----|
| 1. Kings | 949 |
| 2. Private names | 953 |
| 3. Divinities | 990 |
| 4. Geographical | 992 |
| 5. Objects in museums | 992 |

INTRODUCTION

THE first part of the revised edition of Volume III of this work, published in 1974, recorded a more than fourfold increase in the number of pages required for the same section of the Memphite necropolis in the first edition, and soon it became clear that a similar ratio was to be expected for the second part of the volume. This was one of the reasons why we decided to depart from tradition and publish the remaining text in the form of three fascicles, thus spreading over a longer period the considerable printing costs, as well as the time needed for seeing the book through the press. Perhaps even more importantly, the new method of publication enabled us to give Egyptologists at least parts of the work several years earlier than would otherwise have been possible, even though the unavoidable lack of indexes in the first two fascicles made their use somewhat more difficult.

This part of Volume III of the *Topographical Bibliography* deals with the southern half of the Memphite necropolis and the structures at Mît Rahîna. The dividing line between Abûšîr and Şaqqâra is, admittedly, rather tenuous and may become even more so when the area has been more thoroughly excavated. Şaqqâra is by far the most important necropolis here, merging almost imperceptibly into Dahshûr in the south, while Mît Rahîna, in the cultivation zone to the east, nearer the river, is a temple and town site.

The pyramid-field of Şaqqâra has been dealt with using the pattern established in the first edition. Although numerous pyramids of the Old Kingdom and Dynasty XIII at Şaqqâra have never ceased to attract the attention of scholars, much work still remains to be done. The publication of the mortuary temple of Unis was in the press while this book was being prepared, and we are grateful to Professor Leclant for allowing us to see it in proof and so at least partly to complete our documentation. The important reliefs which once adorned the causeway leading to the pyramid have not yet been systematically published, but we have been very fortunate to have at our disposal copies of texts of inscribed blocks made by Professor Černý. In a similar way, we have been able to use Professor Gunn's unpublished descriptions and copies of texts in the mortuary temple of Khuit, one of the Queens of Teti.

For the northern part of the extensive necropolis of Şaqqâra we have used the Step Pyramid enclosure of Neterikhet (Zoser) as our area of reference and divided the private tombs into those situated north, east, and west of it (this is somewhat different from the system employed in the first edition). The width of the Step Pyramid enclosure has also provided the convenient dimension on which to base our grid on maps XLV, XLVI, LI, LVIII, LXIX, and LXX, which is also used in Appendix D and occasionally in the text to indicate the position of tombs. Concentrations of tombs near pyramid-complexes suggested further divisions, with the large area, as yet little explored, between the Monastery of Apa Jeremias and the enclosure of Sekhemkhet in the west being treated as on a par with them. In the case of the tombs near the pyramid of Teti, we have been able to quote extensively from Professor Gunn's copies of monuments excavated by Cecil M. Firth almost sixty years ago. These, as well as the other manuscript sources mentioned above, are kept in the archives of the Griffith Institute.

There is no agreed system of numbering Şaqqâra tombs. The position of many of them can only be derived from old maps, without the possibility of verifying their accuracy and, in view of the lack of a modern survey of the area, it seemed unwise to try to introduce a uniform numbering system, ill-equipped as we are for such a step at present. Each section of the necropolis has, therefore, been treated on its own, usually by dealing with tombs belonging to different numbering schemes in turn or by dividing them according to their relative position and date. The list of contents, Appendix D, and the appropriate maps at the end are designed to help in case of difficulty.

The very substantial sections entitled Tombs of Position Unknown and Objects from Tombs conclude the Şaqqâra necropolis. The number of monuments where a Şaqqâra origin might be suggested could, no doubt, be increased even further, but it has been our policy to err on the side of caution. Our next project, Volume VIII (Objects of Unknown Provenance), will give us an opportunity to include all such pieces and, if desirable, mention a suggested provenance.

It now seems clear that the Serapeum with the tombs of Apis-bulls is only part of a large complex of galleries with burials of sacred animals which, together with temples and shrines, grew up in the northern part of Şaqqâra from the XVIIIth Dynasty and were particularly prominent during the Late and Ptolemaic Periods. Our section called Sacred Animal Complexes has been divided into the Eastern Group, where so far only a few monuments covered by this work have been found, the Western Group, containing the Serapeum with a large number of votive Apis-stelae, and the interesting Northern Group, with the temple of Nektanebos II, the burial place of the Isis Mother-of-Apis cows, and the galleries of mummified ibises, hawks, and baboons. The amount of quoted material, mostly stelae, found by A. Mariette at the site of the Serapeum in the middle of the last century has been greatly increased, and here we owe a great debt of gratitude to Professor Posener who allowed us to consult and use some of the unpublished transcriptions of the texts of Apis-stelae in the Louvre prepared by him, J. Vercoutter and the late M. Malinine.

Although the importance of Mît Rahîna as part of ancient Memphis is not in doubt, only small sections of the site have been systematically explored. We have followed the natural disposition of the remaining structures, as it appears on available maps, thus dividing the area into the Northern Enclosure with the palace of Apries, the large Ptaḥ Enclosure with subsidiary buildings and monuments inside or outside its walls, and the series of *kôms* encircling the enclosures. Compared with the first edition, the most obvious new features are some of the smaller structures near the Enclosure of Ptaḥ, such as the embalming house of Apis-bulls of Sesonchis I, the chapel of Sethos I, the two small temples of Ramesses II, and the tombs of High Priests of Memphis of Dynasty XXII. The last is, with the exception of some First Intermediate Period or Middle Kingdom tombs at Kôm el-Fakhry, the only evidence for burials at Mît Rahîna and corresponds to similar cases of Third Intermediate Period tombs inside or near temple enclosures elsewhere. A temple of Ḥathor built by Ramesses II has been partly excavated at Kôm el-Rabî'a. A temple of Mernepṭaḥ, explored by C. S. Fisher at Kôm el-Qal'a between 1915 and 1920, has not yet been published, but we are able to quote the most important objects thanks to the help of various Egyptologists, in particular the late Professor J. Černý and the staff of the University Museum in Philadelphia, who have provided us with copies of the texts and answered our queries over many years.

The excavation of the lower temple of the southern pyramid-complex of Snefru by A. Fakhry and the work currently carried out on the Middle Kingdom pyramids by German Egyptologists have been the main new developments at Dahshūr. The material has been re-arranged to conform to the other sites in the volume.

The work on the *Topographical Bibliography* would not be possible without the active participation and interest of many other scholars. This not only applies to the period during which the manuscript of a particular volume is being prepared, but is true all the time. To acknowledge this help fully would be an impossible task and the list would have to contain the names of most of those who actively contribute to the progress of the discipline. However, in addition to those already mentioned above, we have to thank specifically at least D. Abou-Ghazi, H. Altenmüller, Dieter Arnold, H. G. Fischer, T. G. H. James, G. T. Martin, H. De Meulenaere, A. M. Moussa, and W. K. Simpson.

Much of the material used in this volume was collected by the previous Editors, Dr. R. L. B. Moss and Mrs. E. W. Burney. Few of us can ever aspire to contributing to Egyptology to the extent they have done by their foresight, sheer hard work and, above all, unflinching optimism.

Although their names do not appear on the title-page of this publication, it owes much to the work done by the other members of the *Topographical Bibliography* team at the Griffith Institute. Miss Helen Murray and Miss Kathleen Lorimer have been involved in the preparation of the whole volume, while Mrs. V. Raisman, Mrs. A. G. Hobby, Miss S. McLachlan and Mrs. J. Wiggin have helped with parts of it. I am also grateful to Mrs. C. Dupuis for her work on our main royal index, to Mrs. E. Hine for typing the manuscript, and to Mrs. M. E. Cox for drawing the maps and plans. The combination of the Ashmolean Library and the Griffith Institute archives has provided an ideal setting for this type of work. My thanks are also due to the Oxford University Press for their competent handling of the complicated printing.

The British Academy has very generously contributed towards the printing costs for each fascicle.

The completion of the Memphite volume marks a point of departure for the whole project. Our next volume, VIII (Objects of Unknown Provenance), will appear in a new form, and the presentation of material will be very different. The main reasons for this are the need for more frequent revisions of the existing volumes, the ever increasing amount of material for inclusion, and the constantly rising printing costs. The new scheme will be computer-based and should enable us to catch up with the technological advances we are witnessing elsewhere.

J. MÁLEK

Oxford, January 1981

LIST OF PLANS

Key-map. The south part of the Memphite Necropolis dealt with in this volume

ṢAQQÂRA

- XL I. Pyramids
- XL II. Necropolis
- XL III [1 and 2]. Pyramid-enclosures of Iput I and Khuit
- XL III [3]. Step Pyramid enclosure of Neterikhet (Zoser)
- XL IV. Pyramid-complex of Pepy II
- XL V. North of the Step Pyramid (north section)
- XL VI. North of the Step Pyramid (south section)
- XL VII. Plans of tombs
- XL VIII. Plan of tomb No. 60 [D 22], Ty
- XL IX-L. Plans of tombs
 - LI. Around Teti pyramid
 - LII. North of Teti pyramid
 - LIII. Plan of the tomb of Khentka Ikhekhi
- LIV-LV. Plans of tombs
 - LVI. Plan of the tomb of Mereruka Meri
 - LVII. Plans of tombs
 - LVIII. East and west of the Step Pyramid
 - LIX. Plans of tombs
 - LX. A group of tombs west of the Step Pyramid
 - LXI. Around the pyramid-complex of Unis and between the Monastery and Sekhemkhet's enclosure (west section)
 - LXII. Around the pyramid-complex of Unis and between the Monastery and Sekhemkhet's enclosure (east section)
- LXIII-LXVI. Plans of tombs
- LXVII [1]. Around pyramids of Pepy I, Merenrē' I, and Isesi
- LXVII [2]. North-east and east of pyramid of Pepy II
- LXVIII. Sacred animal complexes. Western Group with the Serapeum
- LXIX. Sacred animal complexes (west section)
- LXX. Sacred animal complexes (east section)

LIST OF PLANS

MÎT RAHÎNA

- LXXI. General map
- LXXII. Kôm el-Qal'a with palace of Merneptah

DAHSHÛR

- LXXIII. General map (south section)
- LXXIV. General map (north section)
- LXXV. Pyramid-complex of Sesostri III and Middle Kingdom tombs north of the enclosure

LIST OF MAIN SOURCES OF MAPS AND PLANS

All adapted. Full references and sources of plans of individual tombs in the letterpress

| | |
|--|---|
| de Morgan, <i>Carte de la Nécropole Memphite</i> | XLI, XLII, XLV, XLVI, LI, LVIII, LXI, LXII, LXIX, LXX, LXXIII, LXXIV |
| Maragioglio and Rinaldi, <i>Notizie</i> | XLIII [1, 2] |
| Lauer, <i>Pyr. à deg.</i> ii | XLIII [3] |
| Jéquier, <i>Le Monument funéraire de Pepi II</i> , iii | XLIV |
| Smith (W. S.) in Reisner, <i>Tomb Development</i> | XLV, XLVI |
| Quibell, <i>Saqqara (1905-1906)</i> | LI |
| id. (1906-1907) | LI |
| id. (1912-1914) | XLV |
| Emery, <i>Great Tombs</i> , i | XLV |
| id. in <i>J.E.A.</i> 52 (1966) | XLV |
| Firth and Gunn, <i>Teti Pyr. Cem.</i> ii | LII |
| Hassan, <i>Mastabas of Princess Hemet-R' and Others</i> | LX |
| id. <i>The Mastaba of Neb-Kaw-Her</i> | LXI, LXII |
| Barsanti in <i>Ann. Serv.</i> ii (1901) | LXI |
| Zayed in <i>ib.</i> lv (1958) | LXII |
| Moussa and Altenmüller, <i>Das Grab des Nianchchnum und Chnum-hotep</i> | LXII |
| Maspero, <i>Trois années de fouilles</i> [etc.] in <i>Mém. Miss.</i> i | LXVII [1] |
| Jéquier, <i>Tombeaux de particuliers</i> | LXVII [2] |
| Mariette, <i>Sérapéum, Texte</i> | LXVIII [1] |
| Lauer and Picard, <i>Les Statues ptolémaïques du Sarapieion de Memphis</i> | LXVIII [2] |
| Malinine [etc.], <i>Cat.</i> i | LXVIII [3] |
| Martin, <i>Hetepka</i> | LXIX |
| Rhoné, <i>L'Égypte à petites journées</i> (1877) | LXIX |
| Smith (H. S.) and Jeffreys in <i>J.E.A.</i> 64 (1978) | LXX |
| Dimick (J.) in Anthes, <i>Mit Rahineh 1955</i> | LXXI |
| El-Sayed Mahmud, <i>A New Temple for Hathor at Memphis</i> | LXXI |
| Anthes, <i>Mit Rahineh 1956</i> | LXXII [1] |
| C. S. F[isher] in <i>Penn. Mus. Journ.</i> viii (1917) | LXXII [2] |
| Fakhry, <i>Sneferu</i> , i | LXXIII, LXXIV |
| Arnold and Stadelmann in <i>Mit. Kairo</i> , 31 (1975) | LXXIII |
| de Morgan, <i>Dahchour</i> , i | LXXV |
| id. <i>ib.</i> ii | LXXIV, LXXV |

LIST OF ABBREVIATIONS

I. *Publications*

- | | |
|--|--|
| <i>A. J. A.</i> | American Journal of Archaeology. |
| <i>A. J. S. L.</i> | American Journal of Semitic Languages and Literatures, 1895-1941, superseded by Journal of Near Eastern Studies. Chicago. |
| <i>Ä. Z.</i> | Zeitschrift für Ägyptische Sprache und Alterthumskunde. Berlin. |
| <i>Aeg. Inschr.</i> | Ägyptische Inschriften aus den königlichen Museen zu Berlin. Edited by G. Roeder. 2 vols. 1901-24. |
| <i>Aeg. und Vorderasiat. Alterthümer</i> | Ägyptische und Vorderasiatische Alterthümer aus den königlichen Museen zu Berlin. 1895-7. |
| <i>Äg. Sammlung (1966)</i> | Munich. Die ägyptische Sammlung des bayerischen Staates. Ausstellung . . . 21. Juli bis 5. Oktober, 1966. |
| ALDRED, <i>Egypt</i> | ALDRED (C.), Egypt to the end of the Old Kingdom. London, 1965. |
| ALDRED, <i>M.K. Art</i> | ALDRED (C.), Middle Kingdom Art in Ancient Egypt. London, 1950. |
| ALDRED, <i>N.K. Art</i> | ALDRED (C.), New Kingdom Art in Ancient Egypt. London, 1951, 1961. |
| ALDRED, <i>O.K. Art</i> | ALDRED (C.), Old Kingdom Art in Ancient Egypt. London, 1949. |
| AMÉLINEAU, <i>Hist. sépulture</i> | AMÉLINEAU (E.), Histoire de la sépulture et des funérailles dans l'ancienne Égypte, in Annales du Musée Guimet, xxviii, xxix (1896). 2 vols. |
| Amsterdam, <i>5000 jaar</i> | 5000 jaar kunst uit Egypte uit de musea van Kaïro, Alexandrië en Leiden. Rijksmuseum, Amsterdam, 26 okt.-31 dec. 1960. |
| <i>Anc. Eg.</i> | Ancient Egypt, 1914-32, continued as Ancient Egypt and the East, 1933-35. London, etc. |
| ANGIOLETTI and BIGONGIARI, <i>Testimone</i> | ANGIOLETTI (G. B.) and BIGONGIARI (P.), Testimone in Egitto, 2nd ed. Florence, 1969. |
| <i>Ann. Serv.</i> | Annales du Service des Antiquités de l'Égypte. Cairo. |
| ANTHES, <i>Aeg. Plastik</i> | ANTHES (R.), Ägyptische Plastik in Meisterwerken. Stuttgart, 1954. |
| ANTHES, <i>Meisterwerke</i> | ANTHES (R.), Meisterwerke ägyptischer Plastik. [1947]. |
| <i>Archiv aeg. Arch.</i> | Archiv für ägyptische Archaeologie. 1. Jahrgang. Vienna, 1938. |
| <i>Artefact</i> | Leyden. Artefact. 150 jaar Rijksmuseum van Oudheden 1818-1968. |
| ATHANASI, <i>A Brief Account</i> | D'ATHANASI (G.), A Brief Account of the Researches and Discoveries in Upper Egypt, made under the Direction of |

- Henry Salt, Esq., to which is added a Detailed Catalogue of Mr. Salt's Collection of Egyptian Antiquities. London, 1836.
- Ausf. Verz.* Königliche Museen zu Berlin. Ausführliches Verzeichnis der aegyptischen Alterthümer und Gipsabgüsse. 1899.
- B.I.F.A.O.* Bulletin de l'Institut français d'archéologie orientale du Caire. Cairo.
- BAIKIE, Eg. Antiq.* BAIKIE (J.), Egyptian Antiquities in the Nile Valley. London, 1932.
- BAKER, Furniture* BAKER (H. S.), Furniture in the Ancient World. London, 1966.
- BEREND, Principaux monuments* BEREND (W. B.), Principaux monuments du Musée égyptien de Florence. Paris, 1882.
- Bibl. Ég.* Bibliothèque Égyptologique contenant les Œuvres des Égyptologues français . . . publiée sous la direction de G. Maspero. Paris, 1893-1918.
- VON BISSING, Äg. Kunstgeschichte* BISSING (FREIHERR VON), Ägyptische Kunstgeschichte von den ältesten Zeiten bis auf die Eroberung durch die Araber. 2 vols. and plates. Berlin, 1934.
- VON BISSING, Denkmäler* BISSING (FREIHERR VON), Denkmäler ägyptischer Sculptur. Munich, 1914.
- BOESER, Beschreibung* BOESER (P.), Beschreibung der ägyptischen Sammlung des niederländischen Reichsmuseums der Altertümer in Leiden. 12 vols. (Vol. 1 with A. E. J. and J. H. Holwerda). 1905-25.
- BOESER, Cat. (1907)* BOESER (P.), Catalogus van het Rijksmuseum van Oudheden te Leiden. 1907.
- BONOMI, Cat. Colln. Abbott* BONOMI (J.), Catalogue of a Collection of Egyptian Antiquities, the Property of Henry Abbott, Esq., M.D. Cairo, 1846.
- [BONOMI], Cat. . . . Hartwell House* [BONOMI (J.)], Catalogue of the Egyptian Antiquities in the Museum of Hartwell House. 1858.
- BORCHARDT, Denkmäler* BORCHARDT (L.), Denkmäler des alten Reiches. Cat. Caire. 2 vols. 1937-64.
- BORCHARDT, Statuen* BORCHARDT (L.), Statuen und Statuetten von Königen und Privatleuten. Cat. Caire. 5 vols. 1911-36.
- BORCHARDT, Works of Art* BORCHARDT (L.), Works of Art from the Egyptian Museum at Cairo.
- BOREUX, L'Art ég.* BOREUX (C.), L'Art égyptien. 1926.
- BOREUX, Guide* BOREUX (C.), Musée du Louvre. Département des antiquités égyptiennes. Guide-catalogue sommaire. 2 vols. 1932.
- BOREUX, Sculpture* BOREUX (C.), La Sculpture égyptienne au Musée du Louvre. Paris.
- BOTHMER, Eg. Sculp.* BOTHMER (B.), Egyptian Sculpture of the Late Period, 700 B.C. to A.D. 100. The Brooklyn Museum, 1960.
- BREASTED, History* BREASTED (J. H.), A History of Egypt. 1st ed. New York, 1905; 2nd ed. London, 1921.

- BREASTED (Jr.), *Eg. Servant Statues*
- BREASTED (J. H. Jr.), Egyptian Servant Statues. 1948.
- BREMMER, *Eg. kunst Brief Guide*
- BREMMER (H. P.), Egyptische kunst uit het Museum te Leiden. [1924].
- BOTHMER (B. V.) and KEITH (J. L.), Brief Guide to the Department of Ancient Art, 1970, and Brief Guide to the Department of Egyptian and Classical Art, 1974. The Brooklyn Museum.
- Brit. Mus. Quarterly*
- The British Museum Quarterly. London. 1926-73.
- Brooklyn Mus. Ann. Rep.*
- The Brooklyn Museum Annual Report. From 1955-6 to 1958-9 incorporated in The Brooklyn Museum Bulletin and from 1959-60 in The Brooklyn Museum Annual.
- Brooklyn Mus. Bull.*
- The Brooklyn Museum Bulletin, 1939-1960, superseded by The Brooklyn Museum Annual.
- BRUGSCH, *Recueil*
- BRUGSCH (H.), Recueil de monuments égyptiens, 1st part. 1862.
- BRUGSCH, *Reiseberichte*
- BRUGSCH (H.), Reiseberichte aus Aegypten. Leipzig, 1855.
- BRUGSCH, *Thes.*
- BRUGSCH (H.), Thesaurus Inscriptionum Aegyptiacarum. Leipzig, 1883-91.
- Brussels, *5000 ans*
- 5000 ans d'art égyptien. Palais des Beaux-Arts, Bruxelles, Mars-Juin, 1960.
- DE BUCK, *Coffin Texts*
- DE BUCK (A.), The Egyptian Coffin Texts. Edited by A. de Buck and Sir Alan H. Gardiner. 7 vols. Chicago, 1935-61.
- BUHL, *Sarcophagi*
- BUHL (M.-L.), The Late Egyptian Anthropoid Stone Sarcophagi. Nationalmuseets Skrifter, Arkæologisk-Historisk Række, vi. Copenhagen, 1959.
- Bull. Antieke Beschaving*
- Bulletin van de Vereeniging tot Bevordering der Kennis van de Antieke Beschaving, 1926-69, continued as Bulletin Antieke Beschaving.
- Bull. Inst. Ég.*
- Bulletin de l'Institut Égyptien, 1859-1918, continued as Bulletin de l'Institut d'Égypte. Cairo.
- Bull. Mus. Roy.*
- Bulletin des Musées Royaux d'art et d'histoire. Brussels.
- Bull. Soc. fr. d'Ég.*
- Bulletin de la Société française d'égyptologie. Paris.
- Burlington Fine Arts Club*
(1895)
- Burlington Fine Arts Club. Catalogue of an exhibition of ancient Egyptian art, 1895.
- BURTON, *Excerpta hiero.*
- BURTON (J.), Excerpta hieroglyphica. 1825.
- BYVANCK, *De Kunst*
- BYVANCK (A. W.), De Kunst der Oudheid, i. 2nd ed. Leyden, 1947.
- Cahiers d'Hist. Ég.*
- Cahiers d'Histoire Égyptienne. Cairo.
- CAPART, *L'Art ég.*
- CAPART (J.), L'Art égyptien. i, L'Architecture, 1922. ii, La Statuaire, 1942. iii, Les Arts graphiques, 1942. iv, Les Arts mineurs, 1947.
- CAPART, *L'Art ég.* (1909)
and (1911)
- CAPART (J.), L'Art égyptien: choix de documents accompagnés d'indications bibliographiques. 2 Sér. 1909 and 1911.
- CAPART, *Documents*
- CAPART (J.), Documents pour servir à l'étude de l'art égyptien. 2 vols. Paris, 1927-31.
- CAPART, *Limites*
- CAPART (J.), Les Limites de l'Art Égyptien, in Bulletin de

- l'Office International des Instituts d'Archéologie et d'Art, iii [7], 1936.
- CAPART, *Memphis* CAPART (J.) and WERBROUCK (M.), *Memphis à l'ombre des pyramides*. Brussels, 1930.
- CAPART, *Paysage* CAPART (J.), *Le Paysage et les scènes de genre dans l'art égyptien*. Brussels.
- CAPART, *Propos* CAPART (J.), *Propos sur l'art égyptien*. Brussels, 1931.
- CAPART, *Recueil* CAPART (J.), *Recueil de Monuments Égyptiens*. 2 ser. Brussels, 1902-5.
- CAPART, *Rue de Tombeaux* CAPART (J.), *Une Rue de Tombeaux à Saqqarah*. Texte, Planches. Brussels, 1907.
- Capolavori* Capolavori nei Secoli. Enciclopedia universale di tutte le Arti figurative, i [9-12], 1963. Milan. (English ed., *Discovering Art*, i, 1964. London.)
- CAROTTI, *L'Arte* CAROTTI (G.), *L'Arte dell'Antico Egitto*, edited by E. TEA. Milan, 1937.
- Cat. Caire* Catalogue général des antiquités égyptiennes du Musée du Caire.
- CHAMP., *Mon. and Not. descr.* CHAMPOLLION (J.), *Monuments de l'Égypte et de la Nubie*, 4 vols. Paris, 1835-45. *Notices descriptives*, 2 vols. Paris, 1844-89.
- Chron. d'Ég.* Chronique d'Égypte. Brussels.
- Cleveland Mus. Bull.* The Bulletin of The Cleveland Museum of Art.
- Comptes rendus* Académie des Inscriptions et Belles-Lettres. *Comptes rendus*. Paris.
- CURTO, *L'Egitto antico* (1961) CURTO (S.), *L'Egitto antico nelle collezioni dell'Italia settentrionale*. Museo Civico, Bologna. 31 October-3 December 1961. 2nd ed.
- DARESSY, *Statues* DARESSY (G.), *Statues de divinités*. *Cat. Caire*. 1903-6.
- DAUMAS, *Civ. de l'Ég.* DAUMAS (F.), *La Civilisation de l'Égypte pharaonique*. Paris, 1965.
- Descr. Ant.* Description de l'Égypte ou Recueil des observations et des recherches qui ont été faites en Égypte pendant l'expédition de l'armée française. *Antiquités (Planches)*. 5 vols. 1809-22.
- Descr. somm.* Cairo Museum. *Description sommaire des principaux monuments*. 1956.
- DESROCHES-NOBLECOURT, *L'Art ég.* DESROCHES-NOBLECOURT (C.), *L'Art égyptien*. Paris, 1961.
- DONADONI ROVERI, *Sarcofagi egizi* DONADONI ROVERI (A. M.), *I sarcofagi egizi dalle origini alla fine dell'Antico Regno*. Rome, 1969.
- DRIOTON and DU BOURGUET, *Pharaons* DRIOTON (É.) and DU BOURGUET (P.), *Les Pharaons à la conquête de l'art*. 1965.
- DRIOTON and LAUER, *Sakkarah* DRIOTON (É.) and LAUER (J.-P.), *Sakkarah. The Monuments of Zoser*. Cairo, 1939 and 1951. LAUER (J.-P.), *Les pyramides de Sakkarah*. Cairo, 1972.
- DRIOTON and SVED, *Art ég.* DRIOTON (É.) and SVED (É.), *Art égyptien*. Paris, 1950.
- DUCATI, *Guida* DUCATI (P.), *Guida del Museo Civico di Bologna*. 1923.

- DÜMICHEN, *Flotte* DÜMICHEN (J.), Die Flotte einer aegyptischen Koenigin. Leipzig, 1868.
- DÜMICHEN, *Grabpalast* DÜMICHEN (J.), Der Grabpalast des Patuamenap in der Thebanischen Nekropolis. Leipzig, 1884-94.
- DÜMICHEN, *Photo. Result.* DÜMICHEN (J.), Photographische Resultate einer nach Aegypten entsendeten archäologischen Expedition. Berlin, 1871.
- DÜMICHEN, *Resultate* DÜMICHEN (J.), Resultate der 1868 nach Aegypten entsendeten archäologisch-photographischen Expedition. Berlin, 1869.
- EBERS, *Aegypten* EBERS (G.), Aegypten in Bild und Wort. 2 vols. 1879, 1880. (English ed., Egypt: Descriptive, Historical, and Picturesque. 1887.)
- EDWARDS, *Pyramids* (1947), EDWARDS (I. E. S.), The Pyramids of Egypt, 1947 and 1961. (1961)
- Eg. Art . . . Brooklyn* Egyptian Art in the Brooklyn Museum Collection. 1952.
- Egypt Trav. Mag.* Egypt Travel Magazine, Cairo.
- EMERY, *Great Tombs* EMERY (W. B.), Excavations at Saqqara. Great Tombs of the First Dynasty. 3 vols. 1949-58.
- Encycl. phot. Caire* Encyclopédie photographique de l'art. Le Musée du Caire. 1949.
- Encycl. phot. Louvre* Encyclopédie photographique de l'art. Les Antiquités égyptiennes du Musée du Louvre. 1935.
- ENGELBACH, *Introduction* ENGELBACH (R.), Introduction to Egyptian Archaeology with special reference to the Egyptian Museum, Cairo. Cairo, 1st ed. 1946, 2nd ed. 1961.
- ERMAN, *Reden, Rufe und Lieder* ERMAN (A.), Reden, Rufe und Lieder auf Gräberbildern des Alten Reiches. Berlin. Abhandlungen der Preussischen Akademie der Wissenschaften, Phil.-Hist. Klasse, 15, 1918.
- Essen. *5000 Jahre* 5000 Jahre aegyptische Kunst. Villa Hügel, Essen, 15. Mai-27. Aug. 1961.
- FABRETTI, etc., *R. Mus. di Torino* FABRETTI (A.), ROSSI (F.), and LANZONE (R. V.), Regio Museo di Torino. Antichità egizie. 2 vols. 1882, 1888.
- FAKHRY, *Sneferu* FAKHRY (A.), The Monuments of Sneferu at Dahshur. Vol. i: The Bent Pyramid. Vol. ii (in 2 parts): The Valley Temple. Cairo, 1959-61.
- FAVRE, *L'Arte* FAVRE (S.), L'Arte e lo sport nell'Antico Egitto. 1965.
- FAZZINI, *Images for Eternity* FAZZINI (R.), Images for Eternity. Egyptian Art from Berkeley and Brooklyn. San Francisco, M. H. de Young Memorial Museum, July 26-October 18, 1975.
- FECHHEIMER, *Plastik* FECHHEIMER (H.), Die Plastik der Ägypter. Berlin, 1914 and 1923.
- FIRTH [etc.], *Step Pyr.* FIRTH (C. M.), QUIBELL (J. E.), and LAUER (J.-P.), Excavations at Saqqara. The Step Pyramid. 2 vols. Cairo, 1935.
- FIRTH and GUNN, *Teti Pyr. Cem.* FIRTH (C. M.) and GUNN (B.), Excavations at Saqqara. Teti Pyramid Cemeteries. 2 vols. Cairo, 1926.
- FORMAN (W. and B.) and VILÍMKOVÁ, *Eg. Art* FORMAN (W. and B.) and VILÍMKOVÁ (M.), Egyptian Art. London, 1962.

- Führer* (1961)
 GABUS, 175 ans
 GALASSI, *Tehenu*
 GAUTHIER, *Livre des Rois*
 GHALIOUNGUI, *Magic and Medical Science*
Gids
 GOEDICKE, *Rechtsinschriften*
 GORDON, *Twenty-five Plates*
Great Museums
 GRINSELL, *Eg. Pyramids Guide, Eg. Collns.*
Guide, 1st to 3rd
Guide, 3rd and 4th
Guide, 4th to 6th
Guide (Sculpture)
 HAMANN, *Äg. Kunst*
 HARI, *Horemheb*
 HASSAN, *Giza*
 HAYES, *Scepter*
- Führer durch das Berliner Ägyptische Museum. 1961.
 GABUS (J.), 175 ans d'ethnographie à Neuchâtel. Musée d'ethnographie de Neuchâtel du 18 juin au 31 décembre 1967.
 GALASSI (G.), *Tehenu e le origini mediterranee della civiltà egizia*. Rome, 1942.
 GAUTHIER (H.), *Le Livre des Rois d'Égypte*. Mémoires . . . de l'Institut Français d'Archéologie Orientale du Caire. xvii-xxi. 1907-17.
 GHALIOUNGUI (P.), *Magic and Medical Science in Ancient Egypt*. 1963. 2nd ed. *The House of Life Per Ankh*. Magic and Medical Science in Ancient Egypt. Amsterdam, 1973.
 Rijksmuseum van Oudheden te Leiden. *Gids voor de Egyptische Afdeeling*. *Egyptische Kunst en Beschaving* . . . Museum van Oudheden. 1926, 1928, 1937. *Gids voor de verzameling van Egyptische beeldhouwwerken*. 1953.
 GOEDICKE (H.), *Die privaten Rechtsinschriften aus dem Alten Reich*. Vienna, 1970.
 GORDON (A.), *Twenty-five Plates of all the Egyptian Mummies, and other Egyptian Antiquities in England*, London, 1737-9. Sometimes found with *An Essay Towards Explaining the Hieroglyphical Figures, on the Coffin of the Ancient Mummy belonging to Capt. William Lethieulier, and An Essay Towards Explaining the Antient Hieroglyphical Figures, on the Egyptian Mummy, in the Museum of Doctor Mead [etc.]*, London, 1737.
 The Great Museums of the World, Vol. 12. *Egyptian Museum, Cairo, etc.* In Japanese. 1970.
 GRINSELL (L.), *Egyptian Pyramids*. Gloucester, 1947. British Museum. *A Guide to the Egyptian Collections*. 1909, 1930, 1964.
 British Museum. *A Guide to the First, Second and Third Egyptian Rooms*. 1924.
 British Museum. *A Guide to the Third and Fourth Egyptian Rooms*. 1922.
 British Museum. *A Guide to the Fourth, Fifth and Sixth Egyptian Rooms*. 1922.
 British Museum. *A Guide to the Egyptian Galleries (Sculpture)*. 1909.
 HAMANN (R.), *Ägyptische Kunst, Wesen und Geschichte*. Berlin, 1944.
 HARI (R.), *Horemheb et la Reine Moutnedjemet ou La Fin d'une Dynastie*. Geneva, 1964.
 HASSAN (S.), *Excavations at Giza*, 10 vols. 1932-60.
 HAYES (W. C.), *The Scepter of Egypt. A Background for the Study of the Egyptian Antiquities in The Metropolitan Museum of Art*. 2 vols. 1953 and 1959.

- HELCK, *Historisch-biographische Texte*
HELCK, *Urk.* iv
- HICKMANN, *Ägypten*
HICKMANN, *45 Siècles*
Hiero. Texts
HORNEMANN, *Types*
I.L.N.
J.A.O.S.
J.A.R.C.E.
J.E.A.
J.N.E.S.
JACQUET-GORDON, *Domaines*
JAMES, *Corpus*, i
JÉQUIER, *L'Architecture*
JÉQUIER, *Douze ans*
JÉQUIER, *Hist. civ.*
JÉQUIER, *Tombeaux de particuliers*
KAISER, *Äg. Mus. Berlin* (1967)
KAPLONY, *Inschriften*
KAPLONY, *Kleine Beiträge*
KITCHEN, *Ram. Inscr.*
KLEBS, *Reliefs . . . a. R.*
KLEBS, *Reliefs . . . m. R.*
KOEFOED-PETERSEN, *Ægyptisk Billedhuggerkunst*
KOEFOED-PETERSEN, *Cat. des bas-reliefs*
KOEFOED-PETERSEN, *Cat. des statues*
- HELCK (W.), *Historisch-biographische Texte der 2. Zwischenzeit und neue Texte der 18. Dynastie*. Wiesbaden, 1975.
HELCK (W.), continuation of SETHE, *Urkunden der 18. Dynastie*. Berlin, 1955-8, with Übersetzung, 1961.
HICKMANN (H.), *Ägypten*. BESSELER and SCHNEIDER, *Musikgeschichte in Bildern*, ii [1]. Leipzig, 1961.
HICKMANN (H.), *45 Siècles de musique dans l'Égypte ancienne*. Paris, 1956.
Hieroglyphic Texts from Egyptian Stelae, etc., in the British Museum. 9 parts. (Parts 9 and 1² by T. G. H. James.)
HORNEMANN (B.), *Types of Ancient Egyptian Statuary*. 7 parts. 1951-69.
Illustrated London News.
Journal of the American Oriental Society.
Journal of the American Research Center in Egypt.
Journal of Egyptian Archaeology. London.
Journal of Near Eastern Studies. Chicago.
JACQUET-GORDON (H. K.), *Les Noms des domaines funéraires sous l'Ancien Empire égyptien*. Cairo, 1962.
JAMES (T. G. H.), *Corpus of Hieroglyphic Inscriptions in The Brooklyn Museum*. i, From Dynasty I to the end of Dynasty XVIII. Brooklyn, 1974.
JÉQUIER (G.), *L'Architecture et la décoration dans l'ancienne Égypte*. 3 vols. Paris, 1920-4.
JÉQUIER (G.), *Douze ans de fouilles dans la nécropole memphite 1924-1936*. Neuchâtel, 1940.
JÉQUIER (G.), *Histoire de la civilisation égyptienne*. Paris, 1913.
JÉQUIER (G.), *Fouilles à Saqqarah. Tombeaux de particuliers contemporains de Pepi II*. Cairo, 1929.
KAISER (W.), *Ägyptisches Museum Berlin*. Berlin, 1967.
KAPLONY (P.), *Die Inschriften der ägyptischen Frühzeit*. 3 vols. and Supplement. Wiesbaden, 1963-4.
KAPLONY (P.), *Kleine Beiträge zu den Inschriften der ägyptischen Frühzeit*. Wiesbaden, 1966.
KITCHEN (K. A.), *Ramesside Inscriptions Historical and Biographical*. Oxford, 1969- .
KLEBS (L.), *Die Reliefs des alten Reiches*. Heidelberg, 1915.
KLEBS (L.), *Die Reliefs und Malereien des mittleren Reiches*. Heidelberg, 1922.
KOEFOED-PETERSEN (O.), *Ægyptisk Billedhuggerkunst i Ny Carlsberg Glyptotek*. Copenhagen, 1951.
KOEFOED-PETERSEN (O.), *Catalogue des bas-reliefs et peintures égyptiens*. Copenhagen, 1956.
KOEFOED-PETERSEN (O.), *Catalogue des statues et statuettes égyptiennes*. Copenhagen, 1950.

- KOEFOED-PETERSEN, *Eg. Sculpture*
 KOEFOED-PETERSEN, *Rec. inscr.*
 L. D. and *Text*
 L. D. *Ergänz.*
 LACAU, *Sarcophages*
 LACAU, *Stèles*
 LACAU and LAUER, *Pyr. à deg.*
 LANGE, *Äg. Kunst*
 LANGE, *Ägypten. Landschaft*
 LANGE, *Lebensbilder*
 LANGE and HIRMER, *Ägypten. Architektur*
 LANZONE, *Diz.*
 LAUER, *Hist. mon.* i
 LAUER, *Mystère*
 LAUER, *Problème*
 LAUER, *Pyr. à deg.*
 LECA, *Médecine*
 LEEMANS, *Aeg. Mon.*
 LEEMANS, *Descr. rais.*
 LEGRAIN, *Répertoire*
 LEIBOVITCH, *Anc. Eg.*
 LEPSIUS, *Auswahl*
 LIEBLEIN, *Dict.*
- KOEFOED-PETERSEN (O.), *Egyptian Sculpture in the Ny Carlsberg Glyptothek*. Copenhagen, 1962.
 KOEFOED-PETERSEN (OTTO), *Recueil des inscriptions hiéroglyphiques de la Glyptothèque Ny Carlsberg*. Bibliotheca Aegyptiaca, vi. Brussels, 1936.
 LEPSIUS (RICHARD), *Denkmäler aus Aegypten und Aethiopien*. 12 vols. Berlin, 1849-59. Text, 5 vols. Leipzig, 1897-1913.
 LEPSIUS (R.), *Denkmäler aus Aegypten und Aethiopien. Ergänzungsband*. Leipzig, 1913.
 LACAU (P.), *Sarcophages antérieurs au Nouvel Empire*. Cat. Caire. 2 vols. 1904-6.
 LACAU (P.), *Stèles du Nouvel Empire*, i, 1909. Cat. Caire.
 See LAUER, *Pyr. à deg.*
 LANGE (K.), *Ägyptische Kunst*. 1939.
 LANGE (K.), *Ägypten. Landschaft und Kunst*. Berlin, 1943.
 LANGE (K.), *Lebensbilder aus der Pharaonenzeit*. Berlin, 1952.
 LANGE (K.) and HIRMER (M.), *Aegypten. Architektur, Plastik, Malerei, in drei Jahrtausenden*. Munich, 1955, 1957, 1967.
 LANZONE (R.), *Dizionario di mitologia egizia*. 4 vols. Turin, 1881-5, and Amsterdam, 1975.
 LAUER (J.-P.), *Histoire monumentale des Pyramides d'Égypte*. i, *Les Pyramides à Degrés*. Cairo, 1962.
 LAUER (J.-P.), *Le Mystère des pyramides*. Paris, 1974.
 LAUER (J.-P.), *Le Problème des pyramides d'Égypte*. Paris, 1948.
 LAUER (J.-P.), *La Pyramide à degrés*. i. *L'Architecture: Texte*. ii. *L'Architecture: Planches*. iii. *Compléments*. iv. *Inscriptions gravées sur les vases: 1. Planches, 2. Texte*. v. *Inscriptions à l'encre sur les vases*. 5 vols. (Vols. iv and v by LACAU and LAUER). Cairo, 1936-65.
 LECA (A.-P.), *La Médecine égyptienne au temps des Pharaons*. Paris, 1971.
 LEEMANS (CONRADUS), *Aegyptische Monumenten van het Nederlandsche Museum van Oudheden te Leyden*. 3 vols. (Vol. iii, LEEMANS and PLEYTE), 1842-96.
 LEEMANS (CONRADUS), *Description raisonnée des monumens égyptiens du Musée d'antiquités des Pays-Bas, à Leide*. 1840.
 LEGRAIN (G.), *Répertoire généalogique et onomastique du Musée du Caire*. 1908.
 LEIBOVITCH (J.), *Ancient Egypt*. Cairo, 1938.
 LEPSIUS (R.), *Auswahl der wichtigsten Urkunden des aegyptischen Alterthums*. Leipzig, 1842.
 LIEBLEIN (J.), *Dictionnaire de noms hiéroglyphiques en ordre généalogique et alphabétique*, 1871, and *Supplément*, 1892.

- London. *5000 Years* 5000 Years of Egyptian Art. The Diploma Galleries, Royal Academy of Art, London, 22 June to 12 August 1962.
- Louisiana. *5000 års* 5000 års ægyptisk kunst. Louisiana, 1. April–27. Maj 1962.
- LUGN, *Konst* LUGN (PEHR), *Konst och Konsthantverk i Egypten*. Stockholm, 1927.
- M.M.A. Bull.* Bulletin of the Metropolitan Museum of Art, New York.
- MALININE [etc.], *Cat. i* MALININE (M.), POSENER (G.) and VERCOUTTER (J.), *Catalogue des stèles du Sérapéum de Memphis*. Vol. i (in 2 parts). Paris, 1968.
- MARAGIOGLIO and RINALDI, *L'Architettura* MARAGIOGLIO (V.) and RINALDI (C. A.), *L'Architettura delle Piramidi Menfite*, ii–vii. Turin, 1963–70.
- MARAGIOGLIO and RINALDI, *Notizie* MARAGIOGLIO (V.) and RINALDI (C.), *Notizie sulle Piramidi di Zedefrà, Zedkarà Isesi, Teti*. Turin, 1962.
- MARIETTE, *Choix de monuments* MARIETTE (A.), *Choix de monuments et de dessins découverts ou exécutés pendant le déblaiement du Sérapéum de Memphis*. Paris, 1856.
- MARIETTE, *Mastabas* MARIETTE (A.), *Les Mastabas de l'Ancien Empire*. Edited by G. Maspero. Paris, 1882–9.
- MARIETTE, *Mon. div.* MARIETTE (A.), *Monuments divers recueillis en Égypte et en Nubie*. Paris, 1872.
- MARIETTE, *Renseignements* MARIETTE (A.), *Renseignements sur les soixante-quatre Apis trouvés dans les souterrains du Sérapéum*, in *Bulletin archéologique de l'Athenæum français*, 1855–6.
- MARIETTE, *Sérapéum* MARIETTE (A.), *Le Sérapéum de Memphis*. Paris, 1857.
- MARIETTE, *Sérapeum, Texte* MARIETTE (A.), *Le Sérapeum de Memphis, publié d'après le manuscrit de l'auteur par G. Maspero*. Tome i. Paris, 1882.
- MARIETTE, *Voyage* MARIETTE (A.), *Voyage dans la Haute Égypte*. 2 vols. 1893.
- MARTIN, *Hetepka* MARTIN (G. T.), *The Tomb of Hetepka and Other Reliefs and Inscriptions from the Sacred Animal Necropolis North Saqqâra 1964–1973*. In the press (1977).
- MASPERO, *L'Arch. ég.* MASPERO (G.), *L'Archéologie égyptienne*. Paris, 1887 and 1907.
- MASPERO, *Eg. Art* MASPERO (G.), *Egyptian Art*. 1913.
- MASPERO, *Essais* MASPERO (G.), *Essais sur l'Art Égyptien*. Paris, 1912.
- MASPERO, *Guide* MASPERO (G.), *Guide du visiteur au Musée du Caire*. 1915.
- MASPERO, *Hist. anc.* MASPERO (G.), *Histoire ancienne des peuples de l'Orient classique*. i, *Les origines*. ii, *Les premières mêlées*. iii, *Les empires*. Paris, 1895–9.
- MASPERO, *Inscr.* MASPERO (G.), *Les inscriptions des pyramides de Saqqarah*. Paris, 1894. Reprinted from *Rec. Trav.* iii–v (1882–4), vii–xii (1886–92), xiv (1893).
- MASPERO, *Sarcophages* MASPERO (G.), *Sarcophages des époques persane et ptolémaïque*. *Cat. Caire*. 2 vols. (vol. ii with H. GAUTHIER). 1914, 1939.
- MASPERO and GAUTHIER, *Sarcophages* See MASPERO, *Sarcophages*

- MASPERO and ROEDER, *Führer*
MAZAR, *Views*
Mém. Miss.
MEYER, *Fremdvölker*
- MICHALOWSKI, *Art*
MIGLIARINI, *Indication*
MITRY, *Illus. Cat.*
Mitt. D.O.-G.
Mitt. Kairo
MOGENSEN, *Coll. ég.*
Mon. Piot
MONTET, *Scènes*
MORET, *Le Nil*
- DE MORGAN, *Dahchour*, i
and ii
DE MORGAN, *Recherches*
MÜLLER, *Äg. Kunst*
Münchner Jahrb.
MURRAY, *Sculpture*
MURRAY, *Splendour*
N.Y.H.S. Cat.
Nachr. Göttingen
O.L.Z.
P.S.B.A.
PARIBENI, *Architettura*
- MASPERO (G.) and ROEDER (G.), *Führer durch das Ägyptische Museum zu Kairo*. 1912.
MAZAR, and others. *Views of the Biblical World*. 5 vols. 1959-61.
Mémoires publiés par les membres de la Mission archéologique française au Caire.
Photographs described in MEYER (E.), *Bericht über eine Expedition nach Ägypten zur Erforschung der Darstellungen der Fremdvölker*. Sitzungsberichte der königlich preussischen Akademie der Wissenschaften, Berlin, 1913, pp. 769-801. (References in *Bibl.* are to the photographs, not to pages of the Bericht.)
MICHALOWSKI (K.), *The Art of Ancient Egypt*. London, 1969.
MIGLIARINI (A. M.), *Indication succincte des monuments égyptiens du Musée de Florence*. 1859.
MITRY (P.), *Cairo. Illustrated Catalogue of the Egyptian Museum*.
Mitteilungen der Deutschen Orient-Gesellschaft zu Berlin.
Mitteilungen des Deutschen Instituts für Ägyptische Altertumskunde in Kairo.
MOGENSEN (M.), *La Glyptothèque Ny Carlsberg. La collection égyptienne*. In 2 parts. Copenhagen, 1930.
Fondation Piot. *Monuments et mémoires publiés par l'Académie des Inscriptions et Belles-Lettres*. Paris.
MONTET (P.), *Les scènes de la vie privée dans les tombeaux égyptiens de l'Ancien Empire*. 1925.
MORET (A.), *Le Nil et la civilisation égyptienne*. Paris, 1937. (English edition, *The Nile and Egyptian Civilization*, London, 1972.)
DE MORGAN (JACQUES), *Fouilles à Dahchour*. Vol. i, Mars-Juin, 1894; vol. ii, 1894-5. Vienna, 1895, 1903.
DE MORGAN (J.), *Recherches sur les origines de l'Égypte*. 2 vols. Paris, 1896-7.
MÜLLER (H.-W.), *Ägyptische Kunst*. Frankfurt, 1970.
Münchner Jahrbuch der bildenden Kunst.
MURRAY (M. A.), *Egyptian Sculpture*. London, 1930.
MURRAY (M.), *The Splendour that was Egypt*. London, 1949.
Catalogue of the Egyptian Antiquities of the New York Historical Society. 1915.
Nachrichten der Akademie der Wissenschaften in Göttingen, i, Philologisch-historische Klasse.
Orientalistische Literaturzeitung.
Proceedings of the Society of Biblical Archaeology. London, 1878-1918.
PARIBENI (R.), *Architettura dell'Oriente antico. Storia dell'architettura*, 2. Bergamo, 1937.

- PASSALACQUA, *Cat. raisonné* PASSALACQUA (JOSEPH), Catalogue raisonné et historique des antiquités découvertes en Égypte. Paris, 1826.
- Penn. Mus. Bull.* Pennsylvania. University Museum Bulletin.
- Penn. Mus. Journ.* University of Pennsylvania. The Museum Journal.
- PERRING, *Pyramids* PERRING (J. E.), The Pyramids of Gizeh, etc. 3 Parts. London, 1839-42.
- PERROT and CHIPIEZ, *Hist. de l'Art*, i PERROT (G.) and CHIPIEZ (C.), Histoire de l'Art dans l'Antiquité. i, L'Égypte. Paris, 1882.
- PETRIE, *Arts and Crafts* PETRIE (W. M. FLINDERS), The Arts and Crafts of Ancient Egypt. London, 1909.
- PETRIE, *History* PETRIE (W. M. FLINDERS), A History of Egypt. 3 vols. London, 1905-24.
- PIEHL, *Inscr. hiéro.* PIEHL (K.), Inscriptions hiéroglyphiques en Europe et en Égypte. 3 series. Leipzig, 1886-95.
- PIERRET, *Cat.* PIERRET (P.), Louvre. Catalogue de la Salle Historique de la galerie Égyptienne. Paris, 1882.
- PIERRET, *Rec. inscr.* PIERRET (P.), Recueil d'inscriptions inédites du Musée égyptien du Louvre. Études égyptologiques, ii, 1874, and viii, 1878.
- PIRENNE, *Hist. civ.* PIRENNE (J.), Histoire de la civilisation de l'Égypte ancienne. 3 vols. 1961-3.
- POSENER, SAUNERON and YOYOTTE, *Dict. civ.* POSENER (G.), SAUNERON (S.) and YOYOTTE (J.), Dictionnaire de la civilisation égyptienne. Paris, 1959.
- POULSEN, *Äg. Kunst. A. und M.* POULSEN (V.), Ägyptische Kunst. Altes und Mittleres Reich. 1968.
- PRISSE, *L'art ég.* PRISSE D'AVENNES (A.), Histoire de l'art égyptien d'après les monuments. Paris, 1878-9.
- PRISSE, *Mon.* PRISSE D'AVENNES (A.), Monuments égyptiens. Paris, 1847.
- PRITCHARD, *Anc. Near East* PRITCHARD (J.), The Ancient Near East in Pictures, relating to the Old Testament. Princeton, 1954.
- QUIBELL, *Saqqara* QUIBELL (J. E.), Excavations at Saqqara. i, 1905-1906. ii, 1906-1907. iii, 1907-1908. iv, 1908-9, 1909-10. v, 1911-12 (The Tomb of Hesy). vi, 1912-1914. Cairo, 1907-23.
- R.E.A.* Revue de l'Égypte Ancienne, 1927-31, continued as Revue d'Égyptologie. Paris.
- DE RACHEWILTZ, *L'Arte* DE RACHEWILTZ (B.), Incontro con l'arte egiziana. Milan, 1958.
- RAGAI, *L'Art* RAGAI (D.), L'Art pour l'Art dans l'Égypte Antique. Paris, 1940.
- RANKE, *Meisterwerke* RANKE (H.), Meisterwerke der ägyptischen Kunst. Basel, 1948.
- Rec. Trav.* Recueil de Travaux relatifs à la philologie et à l'archéologie égyptiennes et assyriennes. Paris, 1870-1923.
- REINISCH, *Miramar* REINISCH (S.), Die aegyptischen Denkmäler in Miramar. Vienna, 1865.
- REISNER, *Canopics* REISNER (G. A.), Canopics. Cat. Caire. 1967.
- REISNER, *Tomb Development* REISNER (G. A.), The Development of the Egyptian Tomb down to the Accession of Cheops. 1936.

- Rev. Arch.*
Rev. d'Ég.
 REVILLOUT, *Cat.*
 RICHER, *Le Nu*
 RIESTERER, *Kunstschätze*
 . . . *Kairo*
 ROSELLINI, *Mon. Civ.*
 ROSELLINI, *Mon. Stor.*
 ROSS, *The Art of Egypt*
 DE ROUGÉ, *Album photo.*
 DE ROUGÉ, *Inscr. hiéro.*
 DE ROUGÉ, *Notice des*
monuments (1883)
 DE ROUGÉ, *Notice sommaire*
 (1876)
 SAINTE FARE GARNOT,
L'Égypte
 SAMEH, *Daily Life*
 SCHÄFER, *Äg. Kunst*
 SCHÄFER, *Von äg. Kunst*
 SCHÄFER and ANDRAE, *Kunst*
 SCHIAPARELLI, *Mus. Arch.*
Firenze
 SCHMIDT, *Choix* (1910)
 SCHMIDT, *Den Æg. Sam.*
 (1899) and (1908)
 SCHMIDT, *Levende og Døde*
 Revue Archéologique. Paris.
 Revue d'Égyptologie. Publiée par la Société française
 d'Égyptologie. Paris.
 REVILLOUT (E.), Musée du Louvre. Catalogue de sculpture
 égyptienne. Paris.
 RICHER (P.), *Le Nu dans l'Art. Les Arts de l'Orient clas-*
sique, Égypte-Chaldée-Assyrie. Paris, 1925.
 RIESTERER (P.), *Das Ägyptische Museum Kairo. i, Aus-*
gewählte Kostbarkeiten (Kunstschätze aus dem Ägyptischen
Museum, Kairo). 1963, 1976 (latter with K. Lambelet).
 ROSELLINI (I.), *I Monumenti dell'Egitto e della Nubia. ii,*
Monumenti Civili. Pisa, 1834.
 ROSELLINI (I.), *I Monumenti dell'Egitto e della Nubia. iii,*
Monumenti Storici. Pisa, 1832.
 The Art of Egypt through the Ages, edited by E. D. Ross.
 London, 1931.
 DE ROUGÉ (E.), *Album photographique de la Mission*
remplie en Égypte, 1863, 1864.
 DE ROUGÉ (J.), *Inscriptions hiéroglyphiques copiées en*
Égypte pendant la mission scientifique de M. le Vicomte
Emmanuel de Rougé. 4 vols. Paris, 1877-9.
 DE ROUGÉ (E.), *Notice des monuments exposés dans la*
galerie d'Antiquités égyptiennes . . . au Musée du Louvre.
 Paris, 1883.
 DE ROUGÉ (E.), *Notice sommaire des monuments égyptiens*
exposés dans les galeries du Musée du Louvre. Paris,
 1876.
 SAINTE FARE GARNOT (J.), *L'Égypte. Histoire générale de*
l'art. 1950.
 SAMEH (W.), *Daily Life in Ancient Egypt.* 1964.
 SCHÄFER (H.), *Ägyptische Kunst. In Kunstgeschichte in*
Bildern, i. Leipzig, 1913.
 SCHÄFER (H.), *Von ägyptischer Kunst.* 1919 (2 vols.), 1922,
 1930, 1963.
 SCHÄFER (H.) and ANDRAE (W.), *Die Kunst des Alten Orients.*
Propyläen-Kunstgeschichte, 2. Berlin, 1925, 1930, 1942.
 SCHIAPARELLI (E.), *Museo Archeologico di Firenze. Anti-*
chità egizie. Pt. 1, 1887.
 SCHMIDT (V.), *Glyptothèque Ny-Carlsberg. Choix de*
Monuments Égyptiens. Sér. 2. Brussels, 1910.
 SCHMIDT (V.), *Ny Carlsberg Glyptothek. Den Ægyptiske*
Samling. Copenhagen, 1899 and 1908.
 SCHMIDT (V.), *Levende og Døde i det gamle Ægypten.*
Album til Ordning af Sarkofager, Mumiekister, Mumie-
hylstre O. Lign. (References to Sarkofager, Mumiekister
og Mumiehylstre i det Gamle Ægypten. Typologisk Atlas,
 1919, quoted in the earlier volumes of the *Bibl.*, are valid
 for this publication as well.)

- Sculptures et textes* Sculptures et textes poétiques de l'Égypte, in Cahiers d'Art, xxii (1947).
- SÉE, *Grandes villes* SÉE (G.), Grandes villes de l'Égypte antique. Ivry, 1974.
- SÉE, *Naissance* SÉE (G.), Naissance de l'urbanisme dans la vallée du Nil. 1973.
- SETHE, *Pyramidentexte* SETHE (K.), Die altaegyptischen Pyramidentexte nach den Papierabdrücken und Photographien des Berliner Museums. 2 vols. Leipzig, 1908-10.
- SETHE, *Urk. i* SETHE (K.), Urkunden des Alten Reichs. Leipzig, 1932-3.
- SHARPE, *Eg. Antiq.* SHARPE (S.), Egyptian Antiquities in the British Museum. 1862.
- SHARPE, *Eg. Inscr.* SHARPE (S.), Egyptian Inscriptions from the British Museum and other sources. 2 series. 1837-55.
- SHOUKRY, *Privatgrabstatue* SHOUKRY (M. A.), Die Privatgrabstatue im Alten Reich. Supplément aux Annales du Service des Antiquités, Cahier No. 15. Cairo, 1951.
- Sitzungsb. Berlin* Sitzungsberichte der (königlich) preussischen Akademie der Wissenschaften. Philosophisch-historische Klasse. Berlin.
- Sitzungsb. Wien* Österreichische (kaiserliche) Akademie der Wissenschaften. Philosophisch-historische Klasse. Sitzungsberichte. Vienna.
- SMITH, *Anc. Eg.* SMITH (W. S.), Ancient Egypt as represented in the Museum of Fine Arts, Boston. 1942, 1952, 1960.
- SMITH, *Art . . . Anc. Eg.* SMITH (W. S.), The Art and Architecture of Ancient Egypt. 1958.
- SMITH, *Country Life* SMITH (W. S.), Country Life in Ancient Egypt. Museum of Fine Arts, Boston.
- SMITH, *Hist. Eg. Sculp.* SMITH (W. S.), A History of Egyptian Sculpture and Painting in the Old Kingdom. 1946.
- SOGA, *The Nile* SOGA (T.), The Nile in Ancient Egypt. Tourisme historique, 1. Tokyo, 1968. In Japanese.
- SPELEERS, *Rec. inscr.* SPELEERS (L.), Recueil des inscriptions égyptiennes des Musées Royaux du Cinquantenaire à Bruxelles. 1923.
- SPIEGEL, *Hochkultur* SPIEGEL (J.), Das Werden der altägyptischen Hochkultur. Heidelberg, 1953.
- SPIEGELBERG, *Die demotischen Inschriften* SPIEGELBERG (W.), Die demotischen Denkmäler, i. Die demotischen Inschriften. Cat. Caire. 1904.
- SPIEGELBERG, *Geschichte* SPIEGELBERG (W.), Geschichte der ägyptischen Kunst bis zum Hellenismus. Der Alte Orient, Ergänzungsband, 1. 1903.
- Staatl. Sammlung* Munich. Staatliche Sammlung Ägyptischer Kunst. 1972, 1976.
- STAEHELIN, *Tracht* STAEHELIN (E.), Untersuchungen zur ägyptischen Tracht im Alten Reich. Münchner Ägyptologische Studien, 8. Berlin, 1966.
- STEINDORFF, *Cat.* STEINDORFF (G.), Catalogue of the Egyptian Sculpture in the Walters Art Gallery. Baltimore, 1946.

- STEINDORFF, *Kunst* STEINDORFF (G.), Die Kunst der Ägypter. Bauten, Plastik, Kunstgewerbe. Leipzig, 1928.
- STEINDORFF, *A Royal Head* STEINDORFF (G.), A Royal Head from Ancient Egypt. Freer Gallery of Art Occasional Papers, i [5]. Washington, 1951.
- STEWART, *Eg. Stelae*, i STEWART (H. M.), Egyptian Stelae, Reliefs and Paintings from the Petrie Collection. i. The New Kingdom. Warminster, England, 1976.
- Stockholm. 5000 år 5000 år egyptisk konst. Nationalmuseum Stockholm, 16 Sept.–19 Nov. 1961.
- Studi Rosellini* Studi in memoria di Ippolito Rosellini nel primo centenario della morte. 2 vols. Pisa, 1949–55.
- TARCHI, *L'Architettura* TARCHI (U.), L'Architettura e l'arte nell'antico Egitto. Turin.
- TERRACE and FISCHER, TERRACE (E. L. B.) and FISCHER (H. G.), Treasures of the *Treasures* Cairo Museum. London, 1970.
- TOUNY and WENIG, *Sport* TOUNY (A. D.) and WENIG (S.), Der Sport im alten Ägypten. Leipzig, 1969.
- Uebersicht* (1895) and (1923) Uebersicht der kunsthistorischen Sammlungen des Allerhöchsten Kaiserhauses. Vienna, 1895. Übersicht der kunsthistorischen Sammlungen, II. Teil. Vienna, 1923.
- VANDIER, *Eg. Sculpture* VANDIER (J.), Egyptian Sculpture. 1951.
- VANDIER, *Guide* VANDIER (J.), Musée du Louvre. Le Département des Antiquités Égyptiennes. Guide sommaire. 1948, 1952, 1973.
- VANDIER, *Manuel* VANDIER (J.), Manuel d'archéologie égyptienne. 5 vols. Paris, 1952–69.
- VERCOUTTER, *Textes* VERCOUTTER (J.), Textes biographiques du Sérapéum de Memphis. Paris, 1962.
- Vienna. 5000 Jahre 5000 Jahre aegyptische Kunst. Künstlerhaus, Wien, 15. Dez. 1961–15. Feb. 1962.
- VILÍMKOVÁ, *Chefs-d'œuvre* VILÍMKOVÁ (M.), Chefs-d'œuvre de l'art égyptien. 1969.
- Vingt ans* Vingt ans d'acquisitions au Musée du Louvre 1947–1967. Orangerie des Tuileries, Paris, 16 décembre 1967–mars 1968.
- VYSE, *Operations* VYSE (H.), Operations carried on at the Pyramids of Gizeh in 1837. 3 vols. London, 1840–2.
- W.Z.K.M. Wiener Zeitschrift für die Kunde des Morgenlandes.
- WEIGALL, *Anc. Eg. . . . Art* WEIGALL (A.), Ancient Egyptian Works of Art. London. 1924.
- WEILL, *La II^e et la III^e dynasties* WEILL (R.), Les Origines de l'Égypte pharaonique. 1, La II^e et la III^e dynasties. Ann. Mus. Guimet, xxv, 1908.
- WENIG, *Die Frau* WENIG (S.), Die Frau im Alten Ägypten. Leipzig, 1967.
- WERBROUCK, *Pleureuses* WERBROUCK (M.), Les Pleureuses dans l'Égypte ancienne. Brussels, 1938.
- VAN WIJNGAARDEN, VAN WIJNGAARDEN (W. D.), Meesterwerken der Egyptische *Meesterwerken* Kunst te Leiden. 1938.
- WILDUNG, *Die Rolle äg. Könige* WILDUNG (D.), Die Rolle ägyptischer Könige im Bewusstsein ihrer Nachwelt. 1. Münchner ägyptologische Studien, 17. Berlin, 1969.

- WILKINSON, *M. and C.* WILKINSON (J.), *The Manners and Customs of the Ancient Egyptians*. 3 vols. 1837. 2nd series, 2 vols. and vol. of plates, 1841. New edition (Birch), 3 vols. 1878. All London.
- WOLDERING, *Götter* WOLDERING (I.), *Götter und Pharaonen*. Munich, 1967. Eng. ed., *Gods, Men and Pharaohs*, [1967].
- WOLF, *Hochkulturen* WOLF (W.), *Frühe Hochkulturen. Ägypten, Mesopotamien, Ägäis*. Stuttgart, 1969.
- WOLF, *Kunst* WOLF (W.), *Die Kunst Aegyptens: Gestalt und Geschichte*. Stuttgart, 1957.
- WOLTERS, *Führer* WOLTERS (P.), *Führer durch die Glyptothek König Ludwig's I. zu München*. 1928.
- WOLTERS, *Illus. Kat.* WOLTERS (P.), *Illustrierter Katalog der K. Glyptothek zu München*. 1912.
- WRESZ., *Atlas* WRESZINSKI (W.), *Atlas zur altägyptischen Kulturgeschichte*. 3 vols. Leipzig, 1923-42.
- WRESZ., *Bericht* WRESZINSKI (W.), *Bericht über die photographische Expedition von Kairo bis Wadi Halfa zwecks Abschluss der Materialsammlung für meinen Atlas zur altägyptischen Kulturgeschichte*. (Schriften der Königsberger gelehrten Gesellschaft, 4. Jahr, Geisteswissenschaftliche Klasse, Heft 2.) 1927.
- YOUNG, *Hieroglyphics* YOUNG (T.), *Hieroglyphics collected by the Egyptian Society*. 2 vols. 1823-8.
- YOYOTTE, *Treasures Z.D.M.G.* YOYOTTE (J.), *Treasures of the Pharaohs*. Geneva, 1968. *Zeitschrift der Deutschen Morgenländischen Gesellschaft*. Wiesbaden.
- Zürich, *5000 Jahre* 5000 Jahre aegyptische Kunst. Kunsthau Zürich, 11. Feb.-16. April, 1961.

II. *Unpublished Sources*

- ALINARI photos. Taken by Fratelli Alinari, Florence. Egyptian objects in Italian Museums.
- ARCH. LACAU Photographs and papers of Pierre Lacau, in Paris, Centre Documentaire d'Histoire des Religions, 19 avenue d'Iéna.
- ARCHIVES phot. Archives photographiques, Palais Royal, Paris.
- BURTON MSS. In the British Museum, Add. MSS. 25613-75. James Burton was in Egypt and Nubia between 1820 and 1839.
- CAIRO, CENTRE OF DOCUMENTATION photos. Photographs at the Centre of Documentation, 4 Avenue Rameses, Cairo.
- ČERNÝ MSS. and Notebooks* Notebooks and other papers of Jaroslav Černý, with photographs from various sources (1898-1970).
- CRONSTRAND drawings In Stockholm, National Museum. Baltzar Cronstrand was in Egypt in 1836-8.

* Property of the Griffith Institute, Ashmolean Museum, Oxford.

- DARESSY MSS.** In Paris, Collège de France. Notebooks of Georges Daressy (1887-1923).
DAVIES MSS.* Notebooks, etc., of Norman de Garis Davies (1865-1941).
DEVÉRIA squeezes In the Louvre. Made by Théodule Devéria in Egypt between 1858 and 1866.
F.E.R.E. photos. In Brussels, Fondation égyptologique Reine Élisabeth. Photographs from various sources.
GARDINER MSS. and Notebooks* Notebooks and other papers of Sir Alan Gardiner, with photographs from various sources (1879-1963).
GELL MSS.* Papers of Sir William Gell (1777-1836).
GOODWIN MSS. In the British Museum, Add. MSS. 31268-92. Papers of Charles Wycliffe Goodwin (1817-78).
GRDSELOFF MSS.* Papers and photographs of Bernhard Grdseloff (1915-50).
GRIFFITH INST. photos.* Photographs from various sources, now in the Archives of the Griffith Institute.
GUNN MSS. and Notebooks* Notebooks and other papers of Battiscombe Gunn, with photographs from various sources (1883-1950).
HAY MSS. In the British Museum, Add. MSS. 29812-60, 31054. Robert Hay of Linplum and his artists were in Egypt and Nubia between 1824 and 1838.
HOREAU MSS.* Watercolours painted by H. Horeau in 1838.
HOSKINS MSS.* George Alexander Hoskins was in Egypt and Nubia in 1832-3 and 1860-1.
LANE MSS. In the British Museum, Add. MSS. 34080-8. Edward William Lane was in Egypt and Nubia in 1825-8 and 1833-5.
LIEDER squeezes* Made by Rudolph Theophilus Lieder and Alice Lieder in Egypt in 1850-3.
LUMLEY MSS. In the possession of Mrs. Hayne, Spring Bottom, Osmington, Weymouth. J. S. Lumley was in Egypt in 1839 and 1840.
MARBURG INST. photos. In Marburg Institute, Hessen, Germany.
MILNE Photo. Albums* Two albums of photographs taken in Egypt between 1895 and 1906, formerly belonging to J. Grafton Milne.
NESTOR L'HÔTE MSS. In Paris, Bibliothèque Nationale, Nouvelles Acquisitions françaises, 20394-415, and 2 volumes in the Louvre, E. 25423, a, b. Nestor l'Hôte was in Egypt 1828-9 and 1838-9.
NEWBERRY MSS.* Papers of Percy Edward Newberry, with photographs from various sources (1869-1949).
PETRIE GÍZA photos. Taken by Flinders Petrie in the Bulaq (Gíza) Museum. The negatives are kept at University College, London. Prints are at the Griffith Institute. Numbers continue those of PETRIE ITAL. photos.
PETRIE ITAL. photos. Taken by Flinders Petrie in Florence, Turin, and Bologna Museums. The negatives are kept at University College, London. Prints are at the Griffith Institute.

* Property of the Griffith Institute, Ashmolean Museum, Oxford.

- PETRIE in SAYCE MSS.* Notes made by Flinders Petrie in 1880-2, among the papers of the Rev. Archibald Henry Sayce.
- PHILAD. photos. In Philadelphia, University Museum. Taken by the Egyptian Expedition.
- DE RICCI MSS. In Paris, Collège de France. Papers of Seymour de Ricci (1881-1942).
- ST. FERRIOL Diary Diary of Count Louis de Saint Ferriol, who was in Egypt and Nubia between 1839 and 1843. In the possession of the heirs of his son, the late Count Gabriel de Saint Ferriol.
- SAYCE MSS. See PETRIE in SAYCE MSS.
- SEBAH photos. Numbers quoted are those of *Catalogue des Vues d'Égypte, Nubie, Athènes, Constantinople et Brousse* (1875), unless given as part of another reference.
- SEYFFARTH MSS. In Brooklyn Museum. Tracings, squeezes, etc., of objects in museums, made by Gustav Seyffarth (1796-1855).
- VASSALLI MSS. At Castello Sforzesco, Milan. Papers of Luigi Vassalli who was the conservator of the Bulaq Museum and assistant to Mariette, 1859-84. (Numbers quoted are those of Professor Curto's photographs and photocopies in Topographical Bibliography records.)
- WILBOUR MSS. In Brooklyn Museum. Charles Edwin Wilbour was in Egypt in 1880-91.
- WILKINSON MSS.† Lent by Mrs. Godfrey Mosley. Sir J. Gardner Wilkinson was in Egypt and Nubia between 1821 and 1856.
- WILLIAMS rubbings* Rubbings from objects in the British Museum, etc., made by John Williams between 1830 and 1840.

* Property of the Griffith Institute, Ashmolean Museum, Oxford.

† On loan to the Griffith Institute, Ashmolean Museum, Oxford.

NOTE TO READERS

Registers are counted from the top and numbered in Roman figures, heavy type; scenes in registers are described starting with the one nearest to the large figure of deceased unless otherwise stated.

Destroyed scenes or details are indicated by square brackets.

Numbers in round brackets at the beginning of a paragraph refer to position on plans.

When authors are quoted without the title of the book, the full reference will be found at the beginning of the section.

Original copies and publications only are usually included, though secondary ones are given in special cases. For some very extensively published objects, scenes, or views, only selected references are given (indicated by footnotes); however, all important publications have been included.

Tombs shown in heavier outline on the plans of cemeteries are those mentioned in the letterpress.

PYRAMID-FIELD OF ŞAQQÂRA

Maps XLI, XLII

Plan, POCOCKE, *A Description of the East*, i (1743), on pl. xviii facing p. 49; PERRING, *Pyramids*, iii, pl. vii; VYSE, *Operations*, iii, pl. facing p. 37; *L. D.* i. 33-4 [right]; DE MORGAN, *Carte de la Nécropole Memphite*, 5-10; of north part, MARIETTE, *Choix de monuments*, pls. i, ii, pp. 5-7 (repr. in *Bibl. Ég.* xviii, pls. i, ii, pp. 312-13); LAUER, *Saqqara*, on pp. 8-9. Aerial view of north part, CAPART, *Memphis*, pl. on p. xiv; EMERY in *J.E.A.* 51 (1965), pl. ii [1] facing p. 4; id. in *I.L.N.* March 6, 1965, fig. 1 on p. 20; SMITH (H. S.), *A Visit to Ancient Egypt*, frontispiece. View, HOREAU MSS. 4 [1].

I. Pyramids

A. PYRAMID-COMPLEX OF TETI.



MARAGIOGLIO and RINALDI, *Notizie*, pp. 44-54, with plans and sections, Tav. 7-9, 10 [1, 2]. Aerial view, GUNN MSS. xvii. 1 (photo.). See FIRTH and GUNN, *Teti Pyr. Cem.* i, pp. 7-10.

MORTUARY TEMPLE.

LAUER and LECLANT, *Le Temple haut du complexe funéraire du roi Têti*; QUIBELL, *Saqqara (1907-1908)*, pp. 19-22; FIRTH and GUNN, *Teti Pyr. Cem.* i, pp. 7-8. Plan, LAUER in *Bull. Soc. fr. d'Ég.* No. 47 (Dec. 1966), pl. iii, pp. 20, 26-32; id. in *Comptes rendus* (1966), fig. 2, pp. 461-7; id. *Mystère*, fig. 44; LECLANT in *Orientalia*, n.s. 37 (1968), pl. xvii [15] (by Lauer), pp. 104-5; LAUER and LECLANT, pl. xxxv, with sections, pls. xxxvii, xxxviii; QUIBELL, fig. 4. View, id. ib. pl. liii, p. 112; CAPART, *Memphis*, fig. 104; LAUER and LECLANT, pls. ii, iii, xviii [A]; LAUER, *Saqqara*, pls. 151-2.

Masons' graffiti and marks. Name and titles of Pthahshepses, Count, etc., GUNN MSS. R.11.5; Notebook, 20, p. 49 [6]. Others, id. ib. p. 49 [1-5]; R.11.3.

Granite blocks, mostly with names of the King. From jambs, (a) LAUER and LECLANT, pl. xii [A], fig. 6, p. 19; GUNN MSS. R.8.21; Notebook, 20, p. 45 [1, B]; text, QUIBELL, p. 20 [upper]; (b) LAUER and LECLANT, pl. xii [B], p. 19; perhaps same, GUNN MSS. R.8.6; Notebook, 20, p. 45 [2]; (c) LAUER and LECLANT, pl. xii [D], fig. 10, p. 25; text, GUNN Notebook, 20, p. 45 [1, A]; (d) LAUER and LECLANT, pls. xiv [B, C], p. 29. From framing of niches, (e) id. ib. pl. xii [C], p. 27; GUNN MSS. R.8.20; Notebook, 20, p. 46.

Sandstone block with name of the King. Id. ib. p. 47.

Altar, personifications led by Nile-gods, fragments, alabaster. GUNN MSS. R.10.1-4, R.11.1 (repr. LAUER and LECLANT, pl. xxxiv, pp. 19, 87-8 [1], cf. pl. vii [A]); Notebook, 20, p. 48.

Relief-fragments. Numbers are those of Cairo Museum.

A god, and Souls of Nekhen, JE 40028. QUIBELL, pl. liv [1], p. 112; LAUER and LECLANT, pl. xxxiii [C], pp. 93-4 [4].

Head of Sēth, JE 39861. QUIBELL, pl. liv [2], p. 112; LAUER and LECLANT, pl. xxxiii [D], pp. 92-3 [2].

Upper part of the King in *heb-sed* scene, JE 39924. QUIBELL, pl. liv [3], p. 112; LAUER and LECLANT, pl. xxxiii [A], p. 92 [1]; head, STEINDORFF, *A Royal Head*, pl. 28, p. 21.

Upper part of woman Seshseshet , JE 39922. QUIBELL, pl. liv [4], p. 112; LAUER and LECLANT, pl. xxxiii [G], pp. 95-6 [7]; SMITH, *Hist. Eg. Sculp.* pl. 54 [a] (from QUIBELL), p. 202.

Imiut-fetish and shrine, JE 39863. QUIBELL, pl. liv [5], p. 112; LAUER and LECLANT, pl. xxxiii [F], p. 95 [6].

Remains of text, JE 39923. QUIBELL, pl. liv [6], p. 112; LAUER and LECLANT, pl. xxxiii [E], pp. 94-5 [5].



Middle part of the King followed by Isesikhat[ef] , Greatest of the seers, etc., JE 39862. QUIBELL, pl. liv [7], p. 112; LAUER and LECLANT, pl. xxxiii [B], p. 93 [3].

Head of Buto and text. Id. ib. pl. xxiv [D], fig. 23, pp. 65-6; GUNN MSS. R.13.6; xiv. 2 (photos.); R.8.19; Notebook, 20, p. 7 [4]; sketch, ČERNÝ Notebook, 120, p. 100 verso. Two joining blocks from tympanum, (a) text, (b) Nekhbet and Sēth (headless); LAUER and LECLANT, pls. xxii, xxiii [A], figs. 15a, 15b, pp. 60-2 [1]; (b) LECLANT in *Orientalia*, N.S. 36 (1967), pl. xxv [4] (incomplete), p. 188 [b, α]; GUNN MSS. xiv. 1 [3] (photo., reversed); R.8.2 and 18; Notebook, 20, p. 7 [1]. Vulture and text of Sēth; LAUER and LECLANT, pl. xxvii [C], fig. 34, p. 72 [19]; GUNN MSS. R.13.5; xiv. 1 [1] (photos.); R.8.8; Notebook, 20, p. 7 [3]. King's *ka* and two men; LAUER and LECLANT, pl. xxv [A], figs. 24-5, pp. 66-7 [10]. Various, with names of the King, divinities, officials, offering-bringers, etc. LAUER and LECLANT, pls. xxiii [B-D], xxiv [A-C], xxv [B], xxvi, xxvii [A, B], xxviii-xxx, figs. 16-22, 26-33, 35-70, pp. 62-5 [2-8], 68-71 [11-18], 73-83 [20-60]; GUNN MSS. R.8.1, 3-5, 7, 9-14, 16, 17; Notebook, 20, pp. 9-36 [5-110], 41-3 [111-20], and uninscribed, see pp. 37-9 (some repr. in LAUER and LECLANT, figs. 79-89, pp. 88-91 [2-12]). See QUIBELL, p. 20.

Lintel re-used in the Temple of Ptaḥ at Mît Rahîna, see *infra*.

Statues.

Captives, Dyn. VI. (a) Head, in Cairo Mus. JE 40047; QUIBELL, *Saqqara (1907-1908)*, pl. lvi, pp. 20, 113; *I.L.N.* July 7, 1962, fig. on p. 34 [middle left]; Louisiana. 5000 *års*, No. 67 with fig.; Brussels. 5000 *ans*, fig. 16, p. 23 [18]; Essen. 5000 *jahre*, No. 40 with Abb.; LAUER and LECLANT, *Le Temple haut* [etc.], pl. xxxii [B], pp. 98-9 [16]. (b) Fragment; LAUER and LECLANT, op. cit. fig. 73, p. 84 [64].

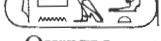
Tetiemsaf  Teti, Chief lector-priest in the Pyramid of Teti, etc., son of Henu  (mother), headless block-stature, with text mentioning appointment by Amenemḥet-ankh  to functions in temples, temp. Sesostri I, in Cairo Mus. JE 40032. QUIBELL, op. cit. pl. lvii [1-3], pp. 113-14, see BOTHMER in *Brooklyn Museum Annual*, ii-iii (1960-2), p. 30 [xii] (as sandstone).

Khnemḥotp, torso, date uncertain. Name, QUIBELL, *Saqqara (1906-1907)*, p. 4.

Alabaster vessels of Teti. Some only probably from here.

(a) Jar, in Brit. Mus. 29204; *Guide, Eg. Colln.* (1930), on fig. 160, p. 300; *Guide, 4th to 6th*, on pl. ii, p. 15 [6]; BUDGE, *The Mummy* (1925), on pl. xxvii [lower]; text, GAUTHIER, *Livre des Rois*, i, p. 148 [v]. (b) Lid-fragment, in Brit. Mus. 22961; PETRIE, *History*, i (1923), fig. 64, p. 100; text, GAUTHIER, op. cit. p. 147 [iv]; see *Guide, 4th to 6th*, p. 15 [7]. (c) Lid-fragment, in Cairo Mus. JE 47038; KAPLONY in *Mitt. Kairo*, 20 (1965), Taf. viii, Abb. 89,

p. 36 [89]. (d) Lid-fragment; LAUER and LECLANT, *Le Temple haut* [etc.], fig. 75, p. 85 [66].
 (e) Lid-fragment; text, QUIBELL, *Saqqara (1906-1907)*, p. 4.

Plaques.

(a) In shape of *hes*-vase of Pepy I, wood, in Cairo Mus. JE 39148; id. ib. (1906-1907), pl. v [4], pp. 4, 72. (b) With name of Pepy II in ink, faience fragment; see id. ib. p. 4 [near top]. (c) Pepy II receiving life from Buto, wood with plaster and gilt; id. ib. pl. v [2], pp. 4 [top], 72; see SMITH, *Hist. Eg. Sculp.* p. 205.

Various.

Death-mask, perhaps of Teti, plaster mould, in Cairo Mus. QUIBELL, *Saqqara (1907-1908)*, pl. lv [1], pp. 20, 112-13, cf. pl. lv [2, 3] (cast); VON BISSING, *Äg. Kunstgeschichte*, Taf. lxvi [402] (from QUIBELL), *Text*, i, p. 90. Cast, BORCHARDT in *Mitt. D.O.-G.* No. 52 (Oct. 1913), Abb. 13, p. 35; ELLIOT SMITH in *Bulletin of the John Rylands Library Manchester*, 4 (1917-18), fig. 3, p. 207; WEIGALL, *Anc. Eg. . . . Art*, 65 (from QUIBELL); PETRIE, *The Making of Egypt*, pl. lxi [1] (from QUIBELL); PIJOÁN, *Summa Artis*, iii (1945), fig. 213; MURRAY, *Splendour*, pl. liv [5]; DAUMAS, *Amour de la vie et sens du divin* [etc.] in *Études Carmélitaines* (1952), pl. facing p. 113; PIRENNE, *Hist. civ.* i, pl. 86 between pp. 268-9. See MASPERO, *Guide*, p. 51 [97 B].

Mace-heads of Teti. Three and fragment, in Cairo Mus. JE 49372-3, 39163, 47225. Two (JE 49372-3), QUIBELL, *Saqqara (1906-1907)*, pl. v [3], p. 72; another two, GUNN MSS. xiv. 1 [2] (photo.), xiv. 1A (texts of three); texts of two, QUIBELL, op. cit. (1907-1908), p. 20 [middle].

Fragment of royal decree, probably Dyn. VI. LAUER and LECLANT, *Le Temple haut* [etc.], pl. xxxi [C], fig. 72, p. 84 [63].

New Kingdom votive stelae. Numbers are those of Cairo Museum.

Mer(y)ptah $\square \text{X} \text{N}$ and son Dḥutmosi, with cartouches of Teti, Dyn. XIX, CG 34188. LACAU, *Stèles*, pl. lxxi, pp. 234-5. Text, BARSANTI in *Ann. Serv.* xiii (1914), pp. 255-6.

Nebnakht offering to Ptah, Rēc-Ḥarakhti, and King Teti, Dyn. XIX, JE 36855.

Userḥēt, Fan-bearer, before Ptah, JE 36854.

Two, deceased adoring [King Teti seated], with three kneeling men below, and King Teti seated, with three people below, Dyn. XIX, latter probably Temp. No. 9.2.15.1. QUIBELL, *Saqqara (1907-1908)*, pl. lvii [4], p. 114.

PYRAMID. Lepsius, XXX; Perring and Vyse, 1.

VYSE, *Operations*, iii, p. 39; L. D. *Text*, i, pp. 188-9. Section, PERRING, *Pyramids*, iii, pl. viii [1]. View, WARD (J.), *Pyramids and Progress*, fig. on p. 49 [lower]; LAUER and LECLANT, *Le Temple haut* [etc.], pl. i [B]. Plan, section and views of North Chapel, id. ib. pls. xxi, xxxvi, pp. 43-4; plan, LAUER, *Mystère*, fig. 20; see FIRTH and GUNN, *Teti Pyr. Cem.* i, pp. 8 [bottom]-9, cf. fig. 2. Plan and sections of interior, MASPERO in *Rec. Trav.* v (1884), pl. i facing p. 2 (repr. *Inscr.* pl. i facing p. 88); LAUER, *Mystère*, fig. 32. Section of Burial Chamber, id. in *Bull. Soc. fr. d'Ég.* No. 47 (Dec. 1966), fig. 2, p. 27; view, No. 22 (Nov. 1956), fig. 3, pp. 59-60; with sarcophagus, LECLANT in *Orientalia*, n.s. 27 (1958), pl. xi [15], p. 85 [e]; id. in *Bull. Inst. Ég.* xlvii (1965-6), 1st pl. after p. 64, cf. pp. 53-63; SAINTE FARE GARNOT in *B.I.F.A.O.* lvii (1958), pl. iv, p. 169. View of Antechamber, LAUER and SAINTE FARE GARNOT in *Ann. Serv.* lv (1958), pl. i, p. 256.

Pyramid-texts.

SETHE, *Pyramidentexte*, i, lines T; iii, pp. 120-4, with plan and disposition on walls; MASPERO in *Rec. Trav.* v (1884), pp. 3-59 (repr. *Inscr.* pp. 89-145); cf. LANGE (H. O.) in *Ä.Z.* xxxiv (1896), pp. 143-4.

Fragments found by Sainte Fare Garnot and Lauer in 1951, 1955-6; some, SAINTE FARE GARNOT in *Mélanges Mariette* (1961), pls. i-vi [Nos. 1-34], pp. 169-71; id. in *B.I.F.A.O.* lvii (1958), pls. i-iii, pp. 165-72; LAUER and SAINTE FARE GARNOT in *Ann. Serv.* lv (1958), pl. ii, pp. 253-61; LECLANT in *Orientalia*, n.s. 27 (1958), pl. x, p. 85 [e]; see SAINTE FARE GARNOT in *Comptes rendus* (1956), pp. 257-62. Fragments found by Lauer and Leclant in 1964-6; some, LECLANT in *Orientalia*, n.s. 35 (1966), pls. viii-x [13-18], p. 137; id. in *Bull. Soc. fr. d'Ég.* No. 46 (July 1966), pl. ii, pp. 11-13; id. in *Bull. Inst. Ég.* xlvii (1965-6), 2nd pl. after p. 64, cf. pp. 53-63; BIETAK in *Archiv für Orientforschung*, xxiii (1970), Abb. 37, pp. 206-7. Thirty-three fragments, in Şaqqâra magazine in 1927; GUNN MSS. xv. 1 (squeezes). Fragment from west wall of Entrance Passage, in London, Univ. Coll. 14539; text, SETHE, *Pyramidentexte*, iii, p. 124 [xiii].

SUBSIDIARY PYRAMID.

FIRTH and GUNN, *Teti Pyr. Cem.* i, p. 8 [lower]; QUIBELL, *Saqqara (1906-1907)*, pp. 1-2 (as Neferkarē), with views, plan and section, pls. i-iv, p. 71; LAUER and LECLANT, *Le Temple haut* [etc.], pp. 37-40, with views, plan and section, pls. xviii [B], xix, fig. 12.

PYRAMID-ENCLOSURE OF IPUT¹ I \square 𓆎 𓆏 . Dyn. VI

LORET in *Bull. Inst. Ég.* iii Sér. 10 (1899), pp. 89-90, 92-3; FIRTH and GUNN, *Teti Pyr. Cem.* i, pp. 11-14. Plans and section, id. ib. figs. 3, 4; MARAGIOGLIO and RINALDI, *Notizie*, Tav. 10 [4-7] (from FIRTH and GUNN), pp. 57-60. Plan, LORET, op. cit. on plan facing p. 100. Titles, FIRTH and GUNN, op. cit. pp. 89-90.

MORTUARY TEMPLE. Plan XLIII [1].

Loose blocks with remains of texts and scenes, id. ib. ii, pls. 56-7; i, pp. 91-2 [10-25].

Room I. Firth and Gunn IV.

(1) Men running. Title and name of one, id. ib. p. 91 [9].

Room II. Firth and Gunn III.

- (2) Offering-bringers. Texts, id. ib. p. 91 [7].
- (3) Man leading ox. See id. ib. p. 91 [8].
- (4) Men bringing haunches. Texts, id. ib. p. 91 [6].

Rooms IV and V. Firth and Gunn II and I.

- (5) Bottom register, offering-bringers. Texts, id. ib. p. 90 [4].
- (6) and (7) Remains of deceased, with name and titles. GUNN MSS. xviii. 54 (photos.). Texts, FIRTH and GUNN, op. cit. i, p. 90 [5].
- (8) Bottom register, men presenting birds. Texts, id. ib. p. 90 [3].
- (9) Offering-table, granite. Id. ib. ii, pl. 55 [2]; i, pp. 14, 90 [2].

¹ [King's daughter of his] body, King's wife (of Teti), King's mother (of Pepy I).

PYRAMID.

False-door, granite, in middle of north face. Id. ib. ii, pl. 55 [1]; i, pp. 14, 90 [2].

Shaft with burial chamber.

Plan and section, id. ib. i, fig. 4, p. 12; MARAGIOGLIO and RINALDI, *Notizie*, Tav. 10 [8-10].

Inscribed objects, in Cairo Mus. Two model cups and two vases, copper, JE 48885-6, 63237-8; FIRTH and GUNN, op. cit. i, fig. 7 (texts), p. 12 [iii]; texts of cups, GAUTHIER in *Ann. Serv.* xxiv (1924), p. 198. Two ointment-slabs, alabaster, JE 59153-4; FIRTH and GUNN, op. cit. ii, pl. 13 [C]; i, p. 12 [iv].

PYRAMID-ENCLOSURE OF KHUIT¹  Dyn. VI

LORET in *Bull. Inst. Ég.* iii Sér. 10 (1899), p. 94, and plan facing p. 100; cf. id. in *A.Z.* xxxix (1901), p. 1; MARAGIOGLIO and RINALDI, *Notizie*, pp. 55-6, and plan, Tav. 10 [3].



MORTUARY TEMPLE. Plan XLIII [2].

GUNN Notebook, 8, pages at end, with plan.

Room I.

(1) Remains of deceased with small naked boy. (2) Butchers.

Room III.

(3) and (4) Remains of offering-bringers. (5) Remains of deceased, son and daughter, with offering-bringers and attendants. (6) Remains of [deceased], with *Ḳar*  , Sole companion.

Sanctuary IV.

(7) and (8) Bottom register on thicknesses of doorways, three offering-bringers. (9) Seven offering-bringers. (10) Offering-bringers before [deceased at table].

Various.

Block, names of deceased and Teti. Text, GAUTHIER, *Livre des Rois*, i, p. 150 [xviii].

Fragment of false-door, perhaps from here. Text, GUNN Notebook, 10, No. 55, and MSS. on xv. 35a.

B. PYRAMID-COMPLEX OF USERKAF.  Dyn. V

MORTUARY TEMPLE. South of the Pyramid.

FIRTH in *Ann. Serv.* xxix (1929), pp. 64-7; LAUER in *Bull. Soc. fr. d'Ég.* No. 12 (Feb. 1953), pp. 32-3; No. 15 (Feb. 1954), pp. 8-13; id. in *Ann. Serv.* liii (1956), pp. 119-33. Plan, FIRTH, op. cit. fig. on p. 66; LAUER in *Ann. Serv.* xlvi (1947), fig. 20, p. 249; id. *Problème*, fig. 20; id. *Mystère*, fig. 41; id. in *Bull. Soc. fr. d'Ég.* No. 15 (Feb. 1954), fig. 1, p. 9; id. in *Ann. Serv.* liii (1956), pls. ii, iii, pp. 120, 122; id. *Les Pyramides de Sakkarah* (1972), fig. 75, p. 22. Plan and sections, MARAGIOGLIO and RINALDI, *L'Architettura*, vii, on Tav. 1, 2, pp. 16-21, cf. 34-9 notes 15-21. View of court of subsidiary pyramid, LAUER in *Ann. Serv.* liii (1956), pl. iv.

Head² of colossal royal statue, probably of Userkaf, wearing *nemes*, granite, in Cairo Mus.

¹ King's wife (of Teti).

² Selected references.

JE 52501. FIRTH in *Ann. Serv.* xxix (1929), pl. i, p. 65; BAIKIE, *Eg. Antiq.* pl. iii [left]; VON BISSING, *Äg. Kunstgeschichte*, Taf. lxvi [404a, 404b], *Text*, i, p. 84; PETRIE, *The Making of Egypt*, pl. lvii [I]; LANGE, *Äg. Kunst*, pl. 20; id. and HIRMER, *Aegypten. Architektur* (1955 and 1957), pls. 50-1; (1967), pls. 46-7; CAPART, *L'Art ég.* ii, pl. 222; GALASSI, *Tehenu*, fig. 96; SMITH, *Hist. Eg. Sculp.* pl. 17 [a], p. 46; MITRY, *Illus. Cat.* No. 6051; LAUER, *Problème*, pl. xii [I]; id. *Mystère*, pl. 2 [b]; id. *Saqqara*, pl. 120; ALDRED, *O.K. Art*, pl. 33; DRIOTON and SVED, *Art ég.* figs. 20-1; *Encycl. phot. Caire*, pl. 22; STEINDORFF, *A Royal Head*, pl. 14 [right], p. 13 [27]; VANDIER, *Eg. Sculpture*, pl. 16; DONADONI, *Arte Egizia*, fig. 31; id. *Egyptian Museum Cairo*, pl. on p. 37; *Descr. somm.* No. 6051 with pl. facing p. 128; SMITH (J. L.), *Tombs, Temples, and Ancient Art*, pl. facing p. 176 [right]; MÜLLER (H. W.) in *Pantheon*, xviii (1960), figs. on p. 110; id. *Äg. Kunst*, Abb. 32; EDWARDS, *Pyramids* (1961), pl. 22; PIRENNE, *Hist. civ.* i, pl. 85 facing p. 268; FAKHRY, *The Pyramids*, fig. 95; FORMAN (W. and B.) and VILÍMKOVÁ, *Eg. Art*, pl. 24 (incomplete); RIESTERER, *Kunstschätze . . . Kairo*, pl. 9; MONTET, *Eternal Egypt*, pl. 26; DRIOTON and DU BOURGUET, *Pharaons*, pl. 23 [upper]; WESTENDORF, *Das Alte Ägypten*, fig. on p. 50; MICHALOWSKI, *Art*, fig. 214; *Great Museums*, pl. 38; ANGIOLETTI and BIGONGIARI, *Testimone*, Tav. 10.

Relief-fragments.

Birds in papyrus thicket, in Cairo Mus. FIRTH in *Ann. Serv.* xxix (1929), pl. ii, p. 66 [III]; WERBROUCK in *Bull. Mus. Roy.* 3 Sér. x (1938), fig. 13, p. 139; CAPART, *Paysage*, fig. 14, p. 15; SMITH, *Hist. Eg. Sculp.* pl. 52 [b], p. 178; id. *Art . . . Anc. Eg.* pl. 47, p. 68; ALDRED in PIGGOTT, *The Dawn of Civilization*, pl. on p. 117 [44]; DRIOTON and DU BOURGUET, *Pharaons*, pl. 14 [upper]; EKSCHMITT, *Das Gedächtnis der Völker*, Abb. on p. 99.

Orchard-scene, with net and birds, fragments. Reconstruction, SMITH, *Art . . . Anc. Eg.* fig. 31, p. 68; id. *Interconnections in the Ancient Near East*, fig. 181; two fragments, fig. 182 [a]. Two birds pecking each other, in Cairo Mus. Temp. No. 6.9.32.1; WRESZ., *Atlas*, iii. 105 [B]; GILBERT in *Chron. d'Ég.* xxxv (1960), fig. 38, pp. 153-5; Stockholm. 5000 år, No. 45 with fig.; Louisiana. 5000 års, No. 71 with fig.; Brussels. 5000 ans, fig. 11, p. 22 [10]; Zürich. 5000 Jahre, Abb. 36, p. 60 [127]; Vienna. 5000 Jahre, No. 22 with Abb.; London. 5000 Years, pl. v [lower], p. 15 [34]; Essen. 5000 Jahre, No. 48 with Abb.; TERRACE and FISCHER, *Treasures*, pp. 49-51 with pls.; LAUER, *Saqqara*, pl. 119; see FIRTH in *Ann. Serv.* xxix (1929), p. 66 [I].

Head of King wearing plumed head-dress, in Cairo Mus. SMITH, *Hist. Eg. Sculp.* pl. 52 [a], p. 178.

Men in boat, and marching crew, fragments; reconstruction, SMITH, *Art . . . Anc. Eg.* fig. 32, p. 69. Upper and Lower Egyptian estates; names, JACQUET-GORDON, *Domaines*, pp. 140-3 [IR5]; Nos. 10 and 17 (of JACQUET-GORDON), ČERNÝ Notebook, 118, on p. 101. Nikatankh and Khnemhotp (tomb D 49) squatting; see SMITH (W. S.) in REISNER, *Tomb Development*, p. 393. Offering-bringers and papyrus-boat building; remains of texts and sketch, ČERNÝ Notebook, 118, on p. 101. King harpooning and butchers, see FIRTH in *Ann. Serv.* xxix (1929), p. 66 [II, IV].

Two blocks of Kha'emwaset (son of Ramesses II), intrusive. GOMAA, *Chaemwese* [etc.], Taf. ii, p. 77 [10, 11].

PYRAMID. Lepsius, XXXI; Perring and Vyse, 2; el-Haram el-Makharbish.

L. D. Text, i, p. 189. Plans and sections, MARAGIOGLIO and RINALDI, *L'Architettura*, vii, on Tav. 1-3, pp. 10-17, cf. 26-35 notes 1-14; PERRING, *Pyramids*, iii, pl. ix [1-4]; VYSE, *Operations*, iii, pl. facing p. 39, cf. pp. 39-41; BURTON MSS. 25620, 126.

C. STEP PYRAMID ENCLOSURE OF NETERIKHET 
(Zoser ). Dyn. III

Plan XLIII [3]

FIRTH [etc.], *Step Pyr.* i, ii; LAUER, *Pyr. à deg.* i-iii; LACAU and LAUER, *ib.* iv and v (vesels); LAUER, *Hist. mon.* i, pp. 65-176; DRIOTON and LAUER, *Sakkarah*; WEILL in *Rev. d'Ég.* iii (1938), pp. 115-27; BURTON MSS. 25618, 62.

Plan,¹ FIRTH [etc.], *Step Pyr.* ii, pl. i; *id.* in *Ann. Serv.* xxviii (1928), pl. iii, pp. 81-8; *id.* in *R.E.A.* iii (1931), pl. i, pp. 4-5; LAUER, *Pyr. à deg.* i, fig. 5; ii, pl. iii; *id.* in *Ann. Serv.* xxix (1929), pl. i, p. 97; xxx (1930), pl. i, pp. 137-40; xxxi (1931), plan, pp. 49-58; *id.* in *B.I.F.A.O.* xxx (1930), pl. i, pp. 333-60; *id.* *Études complémentaires* [etc.] in *Ann. Serv. Cahier*, No. 9 (1948), fig. 5; *id.* TÄCKHOLM and ÅBERG in *Bull. Inst. Ég.* xxxii (1949-50), pl. i, pp. 121-6. Plans and sections, LAUER, *Pyr. à deg.* iii, pl. xxi [4]; *id.* *Hist. mon.* i, plans 13-15. Sections, LAUER, *Pyr. à deg.* i, fig. 218. Reconstructions,¹ some on model, LAUER, *Pyr. à deg.* ii, pls. iv, v; *id.* *Hist. mon.* i, plans 16, 17; *id.* *Problème*, pl. x; *id.* *Mystère*, pl. 5; *id.* *Études complémentaires* [etc.] in *Ann. Serv. Cahier*, No. 9 (1948), pls. ii-vi; *id.* in *I.L.N.* March 27, 1948, fig. 4, p. 360; *id.* in *Comptes rendus* (1956), pl. ii [2], p. 373; *id.* in *Archaeology*, 10 (1957), figs. 1, 2, pp. 274, 277; *id.* in *Bull. Inst. Ég.* xxxviii [1] (1955-6), pl. vi [1], pp. 20, 23; *id.* *Observations sur les pyramides*, pl. i [upper]; *id.* *Les Pyramides de Sakkarah* (1972), figs. 3-7; *id.* *Saqqara*, pls. 90-1; DRIOTON and LAUER, *Sakkarah* (1939), figs. 4, 5; (1951), figs. 2-4, 6, 7; *I.L.N.* June 7, 1952, fig. 1, p. 980.

Vertical aerial view, LAUER, *Pyr. à deg.* ii, pl. ii [1]; FIRTH in *Antiquity*, ii (1928), pl. i, p. 462 (plan); GRINSELL, *Eg. Pyramids*, pl. x facing p. 136; see also views of the Step Pyramid enclosure of Sekhemkhet, *infra*. Aerial view, FIRTH [etc.], *Step Pyr.* ii, pls. 6, 7; *id.* in *Ann. Serv.* xxv (1925), pl. i [1], p. 149; LAUER, *Pyr. à deg.* ii, pl. ii [2]; *id.* *Les Pyramides de Sakkarah* (1972), fig. 2; DRIOTON and LAUER, *Sakkarah* (1939), figs. 2, 3; (1951), fig. 1; *I.L.N.* Jan. 30, 1926, fig. on p. 179 [upper]; GUNN MSS. xii. 19-22 (photos.). Views from top of Step Pyramid, FIRTH [etc.], *Step Pyr.* ii, pls. 4, 5; CAPART in *Chron. d'Ég.* ii (1926-7), fig. on p. 123; *id.* *Memphis*, figs. 86-7.

Masons' graffiti. GUNN MSS. B.3.3; some, LAUER, *Pyr. à deg.* i, figs. 239-47, pp. 242-55; iii, figs. 92-4, p. 77.

STEP PYRAMID. Lepsius, XXXII; Perring and Vyse, 3; el-Haram el-Mudarrag.

FIRTH [etc.], *Step Pyr.* i, pp. 2-7, 25-48 with figs., 51-3, 86-93; LAUER, *Pyr. à deg.* i, pp. 10-67 with figs.; iii, pp. 1-41, 46-8 with figs.; *id.* *Hist. mon.* i, pp. 69-98 with figs.; *L. D. Text*, i, pp. 189-95.

Plans, sections, and view, VALERIANI and SEGATO, *Atlante Monumentale* [etc.], i (1837), pls. 37A, 37B, 37C; VON MINUTOLI, *Reise zum Tempel des Jupiter Ammon* [etc.] (1824), pls. xxvi, xxvii, xxviii [1-3] (by Segato); PERRING, *Pyramids*, iii, pls. ix [6]-xii [1-4]. Plan, sections, and elevations, BORCHARDT, *Entstehung der Pyramide* [etc.], Taf. 6, 7 (repr. in *Beiträge zur äg. Bauforschung und Altertumskunde*, 1). Plans, mostly with sections, *L. D. Text*, i, figs. on pp. 191-2; VYSE, *Operations*, iii, pls. A, D [1-4], B, facing pp. 42, 44, 47, cf. pp. 41-50; FIRTH [etc.], *Step Pyr.* ii, pls. 20-3; LAUER, *Pyr. à deg.* i, fig. 13; ii, pls. ix, xv-xvii, xix, xx; iii, pls. i-iii, xxi [1-3], cf. xxii; *id.* *Hist. mon.* i, plans 7-12; *id.* in *Ann. Serv.* xxix (1929), pl. viii, pp. 126-9; xxxiii (1933), fig. 1, pp. 155-66; xxxiv (1934), pl. i, pp. 54-69; xxxv (1935), pl. i, pp. 66-75; *id.* *Les Pyramides de Sakkarah* (1972), fig. 14;

¹ Selected references.

DRIOTON and LAUER, *Sakkarah* (1939), fig. 7; (1951), fig. 14; BORCHARDT in *Ä.Z.* xxx (1892), Bl. 1, 2, pp. 87-94; BURTON MSS. 25618, 33-4, cf. 35. Description, plan, and sketches, NESTOR L'HÔTE MSS. 20396, 324, 324 verso. Plan, HAY MSS. 29812, 83; BURTON MSS. 25620, 121, 124-5; LANE MSS. 34088, 44. Section, BORCHARDT in *Ä.Z.* 73 (1937), Abb. on p. 114; LAUER in *Rev. Arch.* 6 Sér. xlvii (1956), fig. 5, pp. 8-9.

Views,¹ some with details, L. D. i. 36; VYSE, *Operations*, iii, pl. facing p. 41; MARIETTE, *Voyage*, i, pl. 3, p. 33; SEBAH photo. 49; BÉCHARD and PALMIERI, *L'Égypte et la Nubie* (1887), pl. liv (reversed); FIRTH [etc.], *Step Pyr.* ii, pls. 2, 3, cf. 8, 9, 108; LAUER, *Pyr. à deg.* ii, pls. i, vii, xiv, c, ci, cf. xi-xiii, lxxxvii, cii-civ; id. *Les Pyramides de Sakkarah* (1972), figs. 13, 24; MIETHE, *Unter der Sonne Oberägyptens*, fig. on p. 251; *J.L.N.* Oct. 18, 1924, fig. 2, p. 727; CAPART, *Memphis*, fig. 82; RANKE, *The Art of Ancient Egypt*, and BREASTED, *Geschichte Aegyptens* (1936), 1; PARIBENI, *Architettura*, fig. 20; DRIOTON and LAUER, *Sakkarah* (1939), figs. 1, 6, 39; (1951), figs. 13, 38; VIOLLET and DORESSE, *Egypt*, pls. 40-1; VANDERSLEYEN, *Das Alte Ägypten*, Abb. 13; YOYOTTE, *Treasures*, pl. on p. 11; *Great Museums*, pl. 146; HOSKINS MSS. i. 124. Two stelae, against east face, LAUER in *Ann. Serv.* xxxiv (1934), pl. iii, pp. 65, 67; see id. *Pyr. à deg.* i, p. 190 with fig. North entrance, central shaft with roof blocks, and Saite gallery, FIRTH [etc.], *Step Pyr.* ii, pls. 10-12; LAUER, *Pyr. à deg.* ii, pl. xviii; id. *Les Pyramides de Sakkarah* (1972), figs. 40-2, pp. 4, 12; DRIOTON and LAUER, *Sakkarah* (1939), figs. 38, 48-50; (1951), figs. 49-51. Shaft with roof blocks, LAUER in *Ann. Serv.* liii (1956), fig. 7, p. 165; id. *Mystère*, pl. 6 [a]; id. *Saqqara*, pl. 98; MENDELSSOHN, *The Riddle of the Pyramids*, pl. 8.

Restoration-text of Kha'emwaset (son of Ramesses II), fragments. Text, LAUER, *Pyr. à deg.* iii, p. 52; id. in *Ann. Serv.* xxxix (1939), p. 449. See *Chron. d'Ég.* xv (1940), p. 67.

Granite burial chamber.

Masons' graffiti, incised. GUNN in *Ann. Serv.* xxxv (1935), pls. i-iii, pp. 62-5.

Tiled rooms I and II.

Plan, L. D. *Text*, i, fig. on p. 194. Description, ST. FERRIOL Diary, June 12, 1842.

Lintel and jambs of tiled doorway, with names of the King, in Berlin (East) Mus. 1185. VON MINUTOLI, *Reise zum Tempel des Jupiter Ammon* [etc.] (1824), pl. xxviii [4 a] (by Segato); VALERIANI and SEGATO, *Atlante Monumentale* [etc.], i (1837), pl. 37D; BURTON, *Excerpta hiero.* pl. xxvii [6]; PERRING, *Pyramids*, iii, pl. xii [6]; VYSE, *Operations*, iii, pl. C [upper] facing p. 46; L. D. ii. 2 [f], *Text*, i, p. 194; LEPSIUS, *Auswahl*, vii [middle bottom]; *Aeg. und Vorderasiat. Alterthümer*, Taf. 95; *Aeg. Inschr.* i, p. 1; STUART, *The Funeral Tent* [etc.], pl. 4 facing p. 9; id. *Egypt after the War*, pl. 4 after p. 192; BORCHARDT in *Ä.Z.* xxx (1892), on Bl. 1, pp. 83-7; SCHÄFER and ANDRAE, *Kunst* (1925), 203; STRÖMBOM, *Egyptens Konst*, fig. 31; NEUBURGER, *The Technical Arts and Sciences of the Ancients*, fig. 202; SCHÄFER in *Mitt. Kairo*, iv (1933), Taf. i [a], ii [b], Abb. 1, pp. 1-17; RANKE, *The Art of Ancient Egypt*, and BREASTED, *Geschichte Aegyptens* (1936), 3; BYVANCK, *De Kunst*, pl. xx [73]; LANE MSS. 34088, 17; GUNN MSS. xii. 16 (photo.). Text, WILKINSON, *Modern Egypt and Thebes*, i, p. 368; BURTON MSS. 25621, 136 [6]. *Serekh*, CAPART, *Memphis*, fig. 138. See *Ausf. Verz.* p. 43. Hieroglyphic signs on back of faience tiles lining chambers, some in Berlin (West) Mus. 1239; PERRING, *Pyramids*, iii, pl. xii [10]; VYSE, *Operations*, iii, pl. C [E] facing p. 46; BORCHARDT in *Ä.Z.* xxx (1892), on Bl. 1, pp. 86-7.

¹ Selected references.

Tiled rooms III and IV. Unfinished.

Views, FIRTH [etc.], *Step Pyr.* ii, pls. 13, 14; LAUER, *Hist. mon.* i, pl. viii [1, 2]; id. in *Ann. Serv.* xxxviii (1938), pl. c, pp. 551, 556; id. *Les Pyramides de Sakkarah* (1972), figs. 43-4, p. 4; DRIOTON and LAUER, *Sakkarah* (1939), figs. 51-2; (1951), figs. 52-3; VANDER-SLEYEN, *Das Alte Ägypten*, Abb. 20.

Room III with stelae.

LAUER in *Mon. Piot*, xlix (1957), pp. 1-15. Texts, FIRTH in *Ann. Serv.* xxviii (1928), p. 87.

South stela, King (head destroyed) running. FIRTH [etc.], *Step Pyr.* ii, pl. 15; LAUER in *Mon. Piot*, xlix (1957), pl. i [2], pp. 1-8. Lintel with names, id. ib. fig. 8, p. 11.

Central stela, King in White Crown running. FIRTH [etc.], *Step Pyr.* ii, pls. 16 (with frame of niche), 44 [1]; id. in *Ann. Serv.* xxviii (1928), pl. ii, p. 84; LAUER, *Hist. mon.* i, pls. ix [1], xxviii [3]; id. in *Mon. Piot*, xlix (1957), pl. ii [2], pp. 8-9; id. *Les Pyramides de Sakkarah* (1972), fig. 47, p. 13; DRIOTON and LAUER, *Sakkarah* (1939), figs. 55, 58; (1951), figs. 56, 59; SMITH, *Hist. Eg. Sculp.* pl. 31 [a], pp. 132-3; LICHTENBERGER in *Egypt Trav. Mag.* No. 25 (August 1956), fig. on p. 7 [left]; GONEIM, *The Buried Pyramid*, fig. 5; DE RACHEWILTZ, *L'Arte*, Tav. 9, p. 11; EDWARDS, *Pyramids* (1961), pl. 3 [b]. Baboon, VIKENTIEV in *Bull. Inst. Ég.* xxxii (1949-50), fig. 13, p. 205; xxxvii [1] (1954-5), fig. 6, pp. 140-2; LAUER in *Mon. Piot*, xlix (1957), fig. 7, p. 9. Lintel with names, id. ib. fig. 5, pp. 7, 11.

North stela, King in White Crown. FIRTH [etc.], *Step Pyr.* ii, pl. 17; LAUER, *Hist. mon.* i, pl. ix [2], fig. 54 [A], pp. 166-8; id. in *Mon. Piot*, xlix (1957), fig. 2, p. 8, and fig. 10, p. 13. Shrine, LAUER, *Pyr. à deg.* ii, pl. xxxvii [1]; GALASSI, *Tehenu*, fig. 20. See GARDINER in *J.E.A.* 30 (1944), p. 32, cf. pl. iii [4] (from FIRTH).

Room IV with zad-panels.

Serekh on jamb of doorway. LAUER in *Mon. Piot*, xlix (1957), fig. 6, p. 7.

Spare panel, in Cairo Mus. JE 68921. Id. in *Ann. Serv.* xxxviii (1938), pl. ci, pp. 551-65 with figs. 74-7; id. *Les Pyramides de Sakkarah* (1972), fig. 45, p. 4; id. *Saqqara*, pl. 102; DRIOTON and LAUER, *Sakkarah* (1939), fig. 53; (1951), fig. 54; GALASSI, *Tehenu*, fig. 53; ENGELBACH, *Introduction*, pl. xxv [1]; id. in GLANVILLE, *The Legacy of Egypt*, pl. 17 [5]; part, *Great Museums*, pl. 32; see *Descr. somm.* No. 6278.

Robbers' passage. North-west of Granite Chamber.

Fragments of wooden box with name of Neterikhet, in Cairo Mus. JE 69498-501. FIRTH [etc.], *Step Pyr.* ii, pl. 109 [1, 2, cf. 3, 4]; i, p. 139.

Galleries beneath east part of the Pyramid (I-XI).

Plan of Galleries V-XI, LAUER in *Ann. Serv.* xxxvi (1936), fig. 5, pp. 20-8; xxxvii (1937), fig. 1, pp. 103-7.

Galleries I-V. Tombs of members of the royal family.

I. Sarcophagus, alabaster, fragments; id. ib. xxxv (1935), pp. 68-70 with figs.; id. *Problème*, fig. 21; id. *Mystère*, fig. 24.

II. Pedestals and fragments of two sarcophagi, alabaster; id. in *Ann. Serv.* xxxv (1935), pl. ii [2], pp. 66-7.

III. Sealing of a Treasurer of the King of Lower Egypt, etc., with name of Neterikhet, *in situ* on wall; FIRTH [etc.], *Step Pyr.* ii, pl. 18 [3]; i, pp. 37 [27], 105; LAUER in *Ann. Serv.* xxxiii (1933), pl. i [1], pp. 159-60; text, id. *Pyr. à deg.* i, p. 53.

IV. Pedestal of sarcophagus; see id. in *Ann. Serv.* xxxiii (1933), p. 158 with fig. 2.

V. Two alabaster sarcophagi and remains of wooden gold-encased coffin; FIRTH [etc.], *Step. Pyr.* ii, pls. 18 [4, 5], 19 [1, 2]; LAUER, *Hist. mon.* i, pl. x [1]; id. in *Ann. Serv.* xxxiii (1933), pls. i [3], ii, pp. 162-5 with figs. 4, 5; id. *Les Pyramides de Sakkarah* (1972), fig. 46, p. 4; DRIOTON and LAUER, *Sakkarah* (1939), fig. 54; (1951), fig. 55.

Galleries VI (H) and VII (B). Magazines of stone vessels.

Views, LAUER, *Pyr. à deg.* iii, pls. iv-xiii [1], xiv; id. in *Ann. Serv.* xxxiv (1934), pl. ii, pp. 54-62; xxxv (1935), pl. ii [1], pp. 72-3; xxxvi (1936), pl. ii, pp. 20-5; id. *Saqqara*, pl. 103; id. *Les Pyramides de Sakkarah* (1972), fig. 50, p. 4; id. *Mystère*, pl. 6 [b]; DRIOTON and LAUER, *Sakkarah* (1939), fig. 60; (1951), fig. 61.

Sealings, from VII. Kha'sekhemui, LAUER, *Pyr. à deg.* iii, pl. xix [7, 8], pp. 21, 74; LACAU and LAUER, *ib.* v, figs. 176-7, p. 93. Royal chamberlain of Neterikhet, etc., LAUER, *ib.* iii, pl. xix [9], fig. 91, pp. 18, 35, 74; LACAU and LAUER, *ib.* v, fig. 178, p. 94.

Vessels with incised texts. Numbers are those of Cairo Museum

Mostly fragments and from Galleries VI (H) and VII (B).

LACAU and LAUER, *Pyr. à deg.* iv [1] (plates), iv [2] (text); FIRTH [etc.], *Step. Pyr.* ii, pls. 88-91, 105; i, pp. 119-23, 136-7; LAUER, *Pyr. à deg.* iii, pl. xix [1-4], p. 74; GUNN in *Ann. Serv.* xxviii (1928), pls. i-iii, figs. 1-7, pp. 155-66; MACRAMALLAH in *ib.* xxxvi (1936), pl. ii, pp. 29-32.

(a) With royal names. Dyn. I-II.

LACAU and LAUER, Nos. 1-108, with pls. and figs.

Na'r (Na'rmer). 1, porphyry, JE 88406; MACRAMALLAH, pl. ii [4], pp. 30, 32; name, LAUER, pl. xix [1], pp. 20, 74.

Zer. 4, porphyry, JE 88309. 14, diorite, JE 88284.

Zet. 17, with name of Neith, alabaster; FIRTH [etc.], ii, pl. 105 [5]; i, p. 137.

Kha'sekhem. 18, porphyry; MACRAMALLAH, pl. ii [2], p. 32; see LAUER, p. 22, cf. fig. 43 B.

Khasty (Den), Merpaba (Azab), Irynüter (Semerkhet), and Ka'a. 19, schist, JE 55254-5 (adjoining); FIRTH [etc.], ii, pl. 88 [1]; i, pp. 119-20; GUNN, pl. i [1, 2], fig. 1, pp. 156-7 [A.1], 158 [A.6]. 20, schist; one fragment, FIRTH [etc.], ii, pl. 105 [3]; i, p. 136. 21, schist, JE 88345; LAUER, pl. xix [2], pp. 20, 74.

Khasty (Den). 22, with cords in relief, and name of Iynikhnum  in ink, alabaster, JE 88421; LAUER, pl. xvi [5], p. 72.

Azab. 23, alabaster, JE 88235. 28, with stepped monument, name missing, alabaster, JE 55202; FIRTH [etc.], ii, pl. 91 [8]; i, p. 123; GUNN MSS. xii. 27 [right] (photo.); text, NEWBERRY MSS. ii. E.I. 23b, on 29. With statue of King, 30, name of Smahetepkhnun  in ink on inside, alabaster; FIRTH [etc.], ii, pl. 105 [1]; i, p. 136; 31, schist, JE 55256; FIRTH [etc.], ii, pl. 88 [2]; i, p. 120; GUNN, pl. i [3], pp. 157-8 [A.2]; 34, schist, JE 55259, FIRTH [etc.], ii, pl. 88 [7]; i, p. 120; GUNN, pl. i [6], p. 158 [A.3]. 35, with stepped monument, mentioning *heb-sed*, alabaster; FIRTH [etc.], ii, pl. 105 [7-9]; i, p. 137.

Semerkhet and Ka'a. 38, Semerkhet, schist, JE 55258, joined by two fragments with name of Ka'a; Cairo fragment, FIRTH [etc.], ii, pl. 88 [6]; i, p. 120; GUNN, pl. i [5], p. 158 [A.5]; text, NEWBERRY MSS. ii. E.I. 24. 39, schist, JE 88344; see LAUER, p. 20 [top], cf. fig. 36.

Ḳava. **42**, diorite, JE 55257; FIRTH [etc.], ii, pl. 88 [3]; i, p. 120; GUNN, pl. i [4], p. 159 [A.8]. **43**, schist, JE 55261; FIRTH [etc.], ii, pl. 88 [8]; i, p. 120; GUNN, pl. i [8], pp. 157-8 [A.7]. **46**, schist; see LAUER, p. 22, cf. fig. 50.

Ḥetepsekhemui. **49**, alabaster, JE 88224. **50-1**, alabaster, JE 88223, 88225. **52**, diorite, JE 64891. **58**, with name of Raʿneb (added later), figure of Bubastis, diorite, JE 65413.

Ninüter. **65**, limestone; FIRTH [etc.], ii, pl. 105 [2]; i, p. 136. **67**, diorite, JE 55265; FIRTH [etc.], ii, pl. 89 [5]; i, p. 121; GUNN, pl. ii [4], p. 159 [A.10]. **70**, crystal; FIRTH [etc.], ii, pl. 105 [4]; i, p. 136. **71**, diorite, JE 88374. **72**, diorite, JE 55283; FIRTH [etc.], ii, pl. 89 [9] (reversed); i, p. 121 (as porphyry); GUNN MSS. xii. 26 [bottom right] (photo.); text, NEWBERRY MSS. ii. E.I. on 2. **74**, Ḥetepsekhemui replaced by Ninüter, schist; see LAUER, p. 16. **77**, with figure of Neith, diorite, JE 88418. **78**, diorite, JE 88322.

Ḥetep (Ḥetepsekhemui). **79**, diorite, JE 55262; FIRTH [etc.], ii, pl. 89 [1]; i, p. 120 (as granite); GUNN, pl. ii [1], p. 159 [A.9]. **80**, diorite, JE 59151; FIRTH [etc.], ii, pl. 89 [2]; i, p. 120 (as granite).

Sneferka. **86**, replacing erased name, schist; EMERY, *Great Tombs*, iii, pl. 28 [b], p. 31 with note 12; SWELIM, *Horus Seneferka* [etc.] in *Archaeological and Historical Studies* (Publications of the Archaeological Society of Alexandria), 5 (1974), pl. 1 [a], pp. 72, 74-5.

Sekhemib Perennaʿet. **87-91**, **93**, diorite, JE 55287, 55267, 55263, 59143, 55284, 55266; FIRTH [etc.], ii, pls. 88 [5], 89 [4], 88 [4], 89 [3], 88 [9], 89 [6]; i, pp. 120-1 (JE 55263 as porphyry); JE 55287, GUNN MSS. xii. 26 [top left] (photo.); text, NEWBERRY MSS. ii. E.I. on 2; JE 55267, 55263, 55266, GUNN, pl. ii [6, 2, 5], pp. 159-60 [A.14 with fig. 3, A.11, A.13 with fig. 2]; JE 55284, GUNN MSS. xii. 26 [top right] (photo.); text, NEWBERRY MSS. ii. E.I. on 2; JE 59143, text, id. ib. ii. E.I. 25. **92**, **94**, porphyry, JE 55288, 55264; FIRTH [etc.], ii, pl. 89 [7, 8]; i, p. 121; JE 55288, GUNN MSS. xii. 26 [middle right] (photo.); text, NEWBERRY MSS. ii. E.I. on 2. JE 55264, GUNN, pl. ii [3], p. 159 [A.12].

Ḳhaʿsekhemui Nebwyḥetepimef. **95**, diorite, JE 55293; FIRTH [etc.], ii, pl. 89 [16]; i, pp. 18, 121; see FIRTH in *Ann. Serv.* xxvii (1927), p. 108.

Nubnūfer (probably Raʿneb). **99**, **100**, schist, JE 55268, 55294; FIRTH [etc.], ii, pl. 89 [10, 11]; i, pp. 75, 121; GUNN, pl. ii [7, 8], pp. 153, 160-1 [A.15-16]; text of JE 55294, FIRTH in *Ann. Serv.* xxiv (1924), p. 126.







Weneg. **103**, schist, JE 88343. **104**, schist; LAUER, pl. xix [3], pp. 20, 74; text, GRDSELOFF in *Ann. Serv.* xlv (1944), fig. 30 [a], p. 290. **107**, with name of boat, schist; LAUER, pl. xix [4], p. 74; text, GRDSELOFF, op. cit. fig. 30 [b], p. 290.

Horus . **108**, schist; see QUIBELL in *Ann. Serv.* xxxiv (1934), p. 75; LAUER, p. 4.



Unnumbered. [Mer]pa[ba] (ʿAzab), diorite; GUNN, pl. i [7], p. 158 [A.4].

(b) Private names, titles, etc. Dyn. I-III.

LACAU and LAUER, Nos. **109-161**, with pls. and figs.

109, Waztifni , King's son, diorite, JE 55278; FIRTH [etc.], ii, pl. 90 [3]; i, p. 122; GUNN, pl. iii [4], pp. 162-3 [B.7]; text, NEWBERRY MSS. ii. E.I. on 12. **110**, Mesenka , King's son, diorite, JE 59142; FIRTH [etc.], ii, pl. 91 [1]; i, p. 123; text, NEWBERRY MSS. ii. E.I. 26. **111**, King's daughter, incised on inside, diorite, JE 59144; FIRTH [etc.], ii, pl. 91 [6]; i, p. 123. **113**, Imaseshet , Scribe of the divine writing, diorite, JE 88221; MACRAMALLAH, pl. ii [7], p. 32; see LAUER, p. 22. **118**, Ḥemsobk , Companion, diorite (?), JE 88397. **119**, Setka , Companion, schist, JE 64887. **122**, Pernikai , Prophet of Sopt, etc., schist; lower part, FIRTH [etc.], ii, pl. 105 [6]; i, p. 137. **124**, Hereditary prince, Greatest of the seers, etc., diorite, JE 88355; text, JAMES and APTED, *The Mastaba of Khentika Called Ikhehki*, p. 50 (by Edwards). Peḥentpah , Overseer (*mdḥ*) of sculptors, etc.,

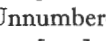





142, diorite, JE 55281, FIRTH [etc.], ii, pl. 90 [12]; i, pp. 122-3; GUNN, pl. iii [10], p. 165 [B.13]; text, NEWBERRY MSS. ii. E.I. on 12; **144**, diorite, in Kofler-Truniger Colln., MÜLLER (H. W.), *Ägyptische Kunstwerke, Kleinfunde und Glas in der Sammlung E. und M. Kofler-Truniger, Luzern*, pl. A81, p. 51; **147-9**, diorite, JE 55285, 59139, 59149; FIRTH [etc.], ii, pl. 90 [13, 11, 14]; i, pp. 122-3; JE 55285, GUNN MSS. xii. 26 [middle left] (photo.); text, NEWBERRY MSS. ii. E.I. on 2. **161**, Ru[ab]en , Overseer (*mdh*) of sculptors, etc., crystal; GUNN, fig. 7, p. 166 [B.14].









Unnumbered. Kanenebef , Servant of the Souls of Nekhen, diorite, JE 55280; FIRTH [etc.], ii, pl. 91 [3]; i, p. 123; GUNN, pl. iii [9], fig. 6, p. 164 [B.12]; text, NEWBERRY MSS. ii. E.I. on 12. Khuitptah , diorite, JE 59140; FIRTH [etc.], ii, pl. 90 [10]; i, p. 122; text, NEWBERRY MSS. ii. E.I. 27. Neferhôtepkhnum , diorite, (a) JE 55286, LACAU and LAUER, *Pyr. à deg.* v, fig. 49, p. 33; FIRTH [etc.], ii, pl. 91 [2]; i, p. 123; GUNN MSS. xii. 26 [top middle] (photo.); text, NEWBERRY MSS. ii. E.I. on 2, 5; (b) JE 55276, LACAU and LAUER, op. cit. fig. 50, p. 33; FIRTH [etc.], ii, pl. 90 [5]; i, p. 122; GUNN, pl. iii [3], p. 162 [B.6]; text, NEWBERRY MSS. ii. E.I. on 13. Diorite, JE 55271; FIRTH [etc.], ii, pl. 89 [13]; i, p. 121; GUNN, pl. ii [11], p. 161 [B.1]; text, NEWBERRY MSS. ii. E.I. 23a [right]. Diorite, JE 55273; FIRTH [etc.], ii, pl. 90 [1, 2]; i, p. 121; GUNN, pl. iii [1, 2], p. 162 [B.5]; text, NEWBERRY MSS. ii. E.I. on 5, on 13. Another, FIRTH [etc.], ii, pl. 90 [4]; i, p. 122 (as JE 59140). Diorite, JE 55279; id. ib. ii, pl. 90 [6]; i, p. 122; incomplete, GUNN, pl. iii [8], p. 164 [B.11]; text, NEWBERRY MSS. ii. E.I. on 12, 22. Diorite, JE 55275; FIRTH [etc.], ii, pl. 90 [7]; i, p. 122; incomplete, GUNN, pl. iii [5, 5a], fig. 4, p. 163 [B.8]; text, NEWBERRY MSS. ii. E.I. on 5, on 13. Diorite, JE 55277; FIRTH [etc.], ii, pl. 90 [8]; i, p. 122; GUNN, pl. iii [6], p. 164 [B.9]; text, NEWBERRY MSS. ii. E.I. on 5, 13, 29. Quartz, JE 55274; FIRTH [etc.], ii, pl. 90 [9]; i, p. 122; GUNN, pl. iii [7], fig. 5, p. 164 [B.10]; text, NEWBERRY MSS. ii. E.I. on 13. Diorite, JE 59145; FIRTH [etc.], ii, pl. 91 [5]; i, p. 123. Porphyry, JE 55289; id. ib. ii, pl. 91 [7]; i, p. 123; GUNN MSS. xii. 26 [middle] (photo.); text, NEWBERRY MSS. ii. E.I. on 2. Diorite, JE 59147; FIRTH [etc.], ii, pl. 91 [9]; i, p. 123. Diorite, JE 59148; id. ib. ii, pl. 91 [10]; i, p. 123. Diorite, JE 59146; id. ib. ii, pl. 91 [11]; i, p. 123. Diorite, JE 55282; id. ib. ii, pl. 91 [4]; i, p. 123; GUNN MSS. xii. 26 [bottom left] (photo.); text, NEWBERRY MSS. ii. E.I. on 2, on 29. Diorite, JE 55269, 55272; FIRTH [etc.], ii, pl. 89 [14, 15]; i, p. 121; GUNN, pl. ii [10, 12], p. 161 [B.2, 4]; text of JE 55269, NEWBERRY MSS. ii. E.I. 23a [left]. Figure of Ptah, LACAU and LAUER, *Pyr. à deg.* v, figs. 27-8, pp. 18-19 [25].



Vessels inscribed in ink. Dyn. I-III. Numbers are those of Cairo Museum

Mostly fragments and from Galleries (VI) H and VII (B).

LACAU and LAUER, *Pyr. à deg.* v, passim, Nos. **1-275** (each number represents one type of text) with pls. and figs.; FIRTH [etc.], *Step Pyr.* ii, pls. 106-7; i, pp. 137-8; GUNN in *Ann. Serv.* xxviii (1928), pl. iv, figs. 8-36, pp. 166-73; QUIBELL in ib. xxxiv (1934), pls. i-iv, pp. 70-5.

1, Menka , Chief Justice and Vizier; QUIBELL, pl. iii [lower middle left], p. 75. **2-8**, Iynikhnum ; FIRTH [etc.], ii, pl. 106 [1-4]; i, p. 137; QUIBELL, pl. iii [bottom left and lower middle right], pp. 73, 75; GUNN, pl. iv [4, 7], figs. 11, 15, pp. 168 [C.4], 170 [C.8]; LAUER, *Pyr. à deg.* iii, pl. xix [5], pp. 5, 74; GOEDICKE in *B.I.F.A.O.* lvi (1957), fig. 1, pp. 152-3. **11**, Nihetep , mentioning *heb-sed*, with title Assistant of Duau; FIRTH [etc.], ii, pl. 107 [2]; i, p. 137; GUNN, fig. 16, p. 170 [D.1]. **12**, Mamin , mentioning *heb-sed*; FIRTH [etc.], pl. 106 [7, 8]; i, p. 137. **16**, 'Aḥaka , mentioning *heb-sed*; FIRTH [etc.], ii, pl. 107 [1]; i, p. 137. **19**, Iufhes ; id. ib. ii, pl. 107 [6]; i, p. 138. **24**,

estate of Hemnūfer; QUIBELL, pl. iii [top left], p. 75; FIRTH [etc.], ii, pl. 107 [3]; i, p. 138. **34-9bis**, numerals, etc.; QUIBELL, pl. iii [upper middle left], p. 75; FIRTH [etc.], ii, pl. 107 [8]; i, p. 138. **69**, Peḥentah , mentioning *heb-sed*; LACAU and LAUER, *Pyr. à deg.* iv, pl. vii [8]. **80**, JE 55291; GUNN MSS. xii. 27 [left] (photo.); similar (name missing), GUNN, pl. iv [8], fig. 14, pp. 168, 170 [C.7]. **85**, Reditnef(?) ; QUIBELL, pl. iii [top right], p. 75. **88-9**, FIRTH [etc.], ii, pl. 106 [5]; i, p. 137. **89bis**, Hemzeser , Leader of the land of the Oryx-nome; another, id. ib. ii, pl. 106 [6]; i, p. 137. **95**, Khnemiotef ; QUIBELL, pl. iii [upper middle right], p. 75. **100**, 'Aḥa ; LAUER, *Pyr. à deg.* iii, pl. xix [6], p. 74. **111**, Khuwi-inpu , Chief of the Great Estate; FIRTH [etc.], ii, pl. 107 [5], p. 138; QUIBELL, pl. iii [bottom right], p. 75; **112**, Judge and Master of the largesse; FIRTH [etc.], ii, pl. 107 [4]; i, p. 138. **144**, Mereru , Scribe of the documents; another, GUNN, fig. 17, p. 170 [D.2]. **158**, Petekhtekh ; FIRTH [etc.], ii, pl. 107 [7]; i, p. 138. **169-70**, id. ib. ii, pl. 103 [on 1]; i, p. 134. **223-72**, hieroglyphic signs; GUNN, pl. iv [6], fig. 13, p. 168 [C.6]. **273**, date, handle bearing *heb-sed* motif, alabaster, JE 64872; FIRTH [etc.], ii, pl. 104 [1, 2]; i, fig. 16, p. 135; LAUER, *Pyr. à deg.* i, fig. 43, pp. 64-5; iii, pl. xvi [1, 2], p. 72; id. *Hist. mon.* i, pl. xii [1], p. 94; id. in *Ann. Serv.* xxxiv (1934), fig. 1, pp. 58-9; id. *Saqqara*, pl. 104; QUIBELL, pl. iv, p. 72; see *Descr. somm.* Nos. 6255-6.

Unnumbered. Rediptahka  , JE 66159; GUNN, pl. iv [1], fig. 8, p. 168 [C.1]. Semenibsheps(?), JE 59141, KAPLONY, *Inschriften, Suppl.* Taf. 30 [1089], p. 37. Texts giving contents, GUNN, figs. 24-36, pp. 172-3 [E.1-13]. Incomplete, GUNN, pl. iv [2, 3, 5], figs. 9, 10, 12, 18-23, pp. 168, 170, 172 [C.2, 3, 5, D.3-8].

MORTUARY TEMPLE.

FIRTH [etc.], *Step Pyr.* i, pp. 8-9, 48-50 with fig.; LAUER, *Pyr. à deg.* i, pp. 72-8 with figs.; id. *Hist. mon.* i, pp. 98-109 with figs. Plan, FIRTH [etc.], *Step Pyr.* ii, pl. 27; LAUER, *Pyr. à deg.* ii, pl. xxii; id. in *Ann. Serv.* xxix (1929), pl. v [upper], pp. 118-26; id. in *B.I.F.A.O.* xxx (1930), pl. ii, p. 337. Reconstruction of façade, FIRTH [etc.], *Step Pyr.* ii, pl. 26 [2]; LAUER, *Pyr. à deg.* ii, pl. xxv [2]; id. *Hist. mon.* i, plan 19 [b]; id. in *Ann. Serv.* xxix (1929), pl. vi [2], p. 121; id. *Saqqara*, pl. 83; with plan, DRIOTON and LAUER, *Sakkarah* (1951), figs. 44-5; LAUER, *Les Pyramides de Sakkarah* (1972), figs. 30-1, p. 11. Views, FIRTH [etc.], *Step Pyr.* ii, pls. 24 [1], 25, 26 [1]; LAUER, *Pyr. à deg.* ii, pls. xxi [1], xxiii [2], xxv [1]; id. *Hist. mon.* i, pl. xiv; *I.L.N.* Jan. 30, 1926, fig. on p. 179 [lower].

Sealings of a Lector-priest, [Prophet of] Neith, with name of Sanakht. FIRTH [etc.], *Step Pyr.* i, fig. 18, p. 141 [a]; LAUER, *Pyr. à deg.* i, fig. 3, p. 5 note 5.

ENCLOSURE WALL AND ENTRANCE COMPLEX.

View of enclosure showing wall, COTTRELL, *The Lost Pharaohs*, pl. 13; LANGE and HIRMER, *Aegypten. Architektur* (1955 and 1957), pl. 7; (1967), pl. 8; GONEIM, *The Buried Pyramid*, fig. 3; DANIEL, *The First Civilizations*, pl. 15; MÜLLER (H. W.) in *Encyclopedia of World Art*, iv, pl. 329 [upper].

Reconstructions, sections and details of wall, LAUER, *Pyr. à deg.* ii, pls. xxviii, xxix; id. in *Ann. Serv.* xxvii (1927), pls. v-vii, figs. 23-9, pp. 126-33. Reconstructions, FIRTH [etc.], *Step Pyr.* ii, pls. 34, 49 [1]; LAUER in *R.E.A.* iii (1931), pl. ix, p. 15; *I.L.N.* Jan. 7, 1928, fig. 3, p. 8. See FIRTH [etc.], *Step Pyr.* i, pp. 9-10, 53-4; LAUER, *Pyr. à deg.* i, pp. 82-94 with figs.; id. *Hist. mon.* i, p. 110.

View of wall,¹ FIRTH [etc.], *Step Pyr.* ii, pls. 32-3; id. in *R.E.A.* iii (1931), fig. 1, p. 4;

¹ Selected references. See also views of superstructure of South Tomb, *infra*.

LAUER, *Pyr. à deg.* ii, pls. xxvi, xxx [upper], xcii [4]; id. *Hist. mon.* i, pl. xxxvii [1], cf. reconstruction, on plan 23 [a]; id. in *I.L.N.* March 27, 1948, fig. 6, p. 360; June 7, 1952, fig. 3, p. 980; id. *Les Pyramides de Sakkarah* (1972), figs. 64-5, p. 15; id. *Saqqara*, pl. 96; SCHÄFER and ANDRAE, *Kunst* (1930), 209 [upper]; CLARKE and ENGELBACH, *Ancient Egyptian Masonry*, fig. 91; CAPART, *Memphis*, fig. 93; ROBICHON and VARILLE, *En Égypte* (1937), pl. 37; (1955), fig. 35; PARIBENI, *Architettura*, figs. 28-30; SMITH (E. B.), *Egyptian Architecture as Cultural Expression*, pl. xiv [2]; BORCHARDT and RICKE, *Egypt*, pl. 92; DRIOTON and LAUER, *Sakkarah*, figs. 28-9; GALASSI, *Tehenu*, fig. 34; LANGE, *Ägypten. Landschaft*, pl. 37; BADAWY, *A History of Egyptian Architecture*, i, pl. iii [b]; VIOLLET and DORESSE, *Egypt*, pl. 42; MICHAŁOWSKI, *Piramidy i mastaby*, pl. 10.

View¹ of entrance. Before restoration, LAUER in *I.L.N.* March 27, 1948, fig. 9, p. 361; before and after restoration, id. in *Ann. Serv.* xlvi (1948), pls. i-iii, p. 355; id. *Hist. mon.* i, pls. xvi, xvii; id. in *Bull. Inst. Ég.* xlvi (1965-6), pl. i, pp. 33-6; after restoration, PERKINS in *A. J. A.* liii (1949), pl. vii [B], pp. 40-1; LAUER in *Bull. Soc. fr. d'Ég.* No. 5 (Dec. 1950), pl. iv, pp. 87-8; id. in *Comptes rendus* (1950), fig. on p. 311; (1956), pl. ii [1], p. 373; id. in *Bull. Inst. Ég.* xxxviii [1] (1955-6), pl. vi [2], p. 23; id. in *Archaeology*, 10 (1957), fig. 3, p. 278; id. in *Ann. Serv.* liii (1956), pls. i, ii, pp. 153-5; liv (1957), pl. i, p. 104 [A], and pp. 109-10 with pls. i, ii (with reconstruction), cf. iii; LECLANT in *Orientalia*, n.s. 19 (1950), pl. liv [3], p. 491 [7, a]; 22 (1953), pl. xv [29], p. 93 [c]; 27 (1958), pls. viii-ix [9-11], p. 84 [b]; id. and RACCAH, *Dans les pas des Pharaons*, pl. 7; DRIOTON and LAUER, *Sakkarah* (1951), fig. 5; VIOLLET and DORESSE, *Egypt*, pl. 43; BADAWY, *A History of Egyptian Architecture*, i, pl. iii [a]; LANGE and HIRMER, *Ägypten. Architektur*, pl. 9; MÜLLER, *Äg. Kunst*, Abb. 16; GONEIM, *The Buried Pyramid*, fig. 2; EDWARDS, *Pyramids* (1961), pl. 5 [b]; GIEDION, *The Eternal Present*, ii, pls. ii, iii; DE CENIVAL, *Living Architecture: Egyptian*, pls. 21, 22-3 [left], 24; POULSEN, *Äg. Kunst. A. und M.* pls. on pp. 1, 35; MICHAŁOWSKI, *Piramidy i mastaby*, pl. 3; VANDERSLEYEN, *Das Alte Ägypten*, Abb. 10.

Plan of colonnade, FIRTH in *Ann. Serv.* xxvi (1926), before pl. i, pp. 97-101; LAUER in *ib.* xxix (1929), pl. ii, pp. 98-102. Plan and reconstructed sections, FIRTH [etc.], *Step Pyr.* ii, pls. 54-5; LAUER, *Pyr. à deg.* ii, pls. xxxviii, xli-xliv; id. in *Ann. Serv.* xxvii (1927), pls. iii, iv, pp. 121-6 with figs.; xxxii (1932), pls. i-iii, pp. 81-92 with figs.; sections, id. *Hist. mon.* i, plan 19 [a]; id. in *R.E.A.* iii (1931), pl. viii, p. 15; *I.L.N.* Jan. 7, 1928, figs. 4, 5, p. 8; reconstruction, LAUER, *Pyr. à deg.* ii, pl. xlv; id. *Les Pyramides de Sakkarah* (1972), fig. 12, p. 6; DRIOTON and LAUER, *Sakkarah* (1939), fig. 14; (1951), fig. 10. See FIRTH [etc.], *Step Pyr.* i, pp. 13-15, 64-7; LAUER, *Pyr. à deg.* i, pp. 113-29 with figs.; id. *Hist. mon.* i, pp. 110-15 with figs.; id. in *Ann. Serv.* xxxix (1939), pp. 472-7 with fig. 46.

View¹ of colonnade, FIRTH [etc.], *Step. Pyr.* ii, pls. 50-3; id. in *Ann. Serv.* xxvi (1926), pls. ii, iii, pp. 97-101; id. in *Antiquity*, ii (1928), pl. ii, p. 461; id. in *R.E.A.* iii (1931), pl. ii, p. 5; LAUER, *Pyr. à deg.* i, frontispiece; ii, pls. xxxix, xl, xlvi-xlviii; id. *Hist. mon.* i, pls. xviii, xix, cf. reconstruction, plan 18; id. in *Ann. Serv.* xxx (1930), pl. i, pp. 129-33 with figs.; xxxi (1931), pl. ii, pp. 65-9; xxxiii (1933), pp. 146-52 with pl., cf. fig. on p. 149; id. in *Mélanges Maspero*, i [2], pp. 413-21 with figs. and pl.; id. in *I.L.N.* March 27, 1948, fig. 7, p. 361; id. in *Bull. Inst. Ég.* xxxviii [1] (1955-6), pl. i, p. 22; id. in *Archaeology*, 10 (1957), fig. 5, p. 278; id. *Les Pyramides de Sakkarah* (1972), figs. 8-11, pp. 6-7; id. *Saqqara*, pls. 86-8; CAPART in *Chron. d'Ég.* ii (1926-7), fig. on p. 125; id. *Memphis*, fig. 91; STEINDORFF, *Kunst*, 109; CLARKE and ENGELBACH, *Ancient Egyptian Masonry*, figs. 3, 4; POULSEN (F.), *Ägyptens Kunst* (1933), fig. 17; VON BISSING, *Äg. Kunstgeschichte*, Taf. xxix [234], *Text*, i, pp. 52-3; RANKE, *The Art of Ancient Egypt*, and BREASTED, *Geschichte Aegyptens* (1936), 8;

¹ Selected references.

PARIBENI, *Architettura*, figs. 31, 33, cf. 32; MURRAY, *Egyptian Temples*, pl. vii [2]; SCHARFF in OTTO, *Handbuch der Archäologie*, i, Taf. 59 [3], p. 467; LANGE and HIRMER, *Aegypten. Architektur*, pls. 10, 11; DRIOTON and LAUER, *Sakkarah* (1939), figs. 8-13; (1951), figs. 8, 9, 11, 12; GALASSI, *Tehenu*, figs. 31, 33; HAMANN, *Äg. Kunst*, Abb. 110-11; PIJOÁN, *Summa Artis*, iii (1945), figs. 94-5; DRIOTON and SVED, *Art ég.* figs. 2, 3; VIOLETT and DORESSE, *Egypt*, pls. 44-5; GIEDION, *The Eternal Present*, ii, pl. iv; DE CENIVAL, *Living Architecture: Egyptian*, pl. 26; VANDERSLEYEN, *Das Alte Ägypten*, Abb. 11, 12.

Found in colonnade and near by.

Base and fragments of statue of Neterikhet standing on *rekhyt*-birds and bows, with name and titles of Imḥōtep, in Cairo Mus. JE 49889, 49889a-g (another fragment of base, LAUER in *Ann. Serv.* xxxix (1939), fig. 36, p. 448). GUNN in *Ann. Serv.* xxvi (1926), pp. 177-96 with figs.; FIRTH in *ib.* pl. i, pp. 99-100; *id.* [etc.], *Step Pyr.* ii, pl. 58; i, pp. 65-6; CAPART, *Memphis*, fig. 140; *id.* *Documents*, ii, pl. 32 [B]; SMITH, *Hist. Eg. Sculp.* pl. 31 [c], p. 138; FRANKFORT, *Ancient Egyptian Religion*, pl. 18; LAUER, *Hist. mon.* i, pl. xxxv [3]; *id.* *Les Pyramides de Sakkarah* (1972), fig. 55, p. 3; *id.* *Saqqara*, pl. 89. Text, SETHE, *Urk.* i. 153 [I (92)]. Name and titles of Imḥōtep, JUNKER, *Giza*, xii, Abb. 7, p. 101. See *Descr. somm.* No. 6009.



Torso of royal statue, in Cairo Mus. JE 60487. FIRTH [etc.], *Step Pyr.* ii, pl. 59; i, p. 66.

Group of two heads of captives, granite, Dyn. III, in Cairo Mus. JE 49613. *Id.* *ib.* ii, pl. 57 [1]; i, pp. 66-7; *id.* in *Ann. Serv.* xxvi (1926), pl. iv [B], p. 99; *Chron. d'Ég.* i (1925-6), fig. on p. 82; ii (1926-7), fig. on p. 67 [lower]; EVERS, *Staat aus dem Stein*, ii, Taf. v [46], pp. 91-3 [617-27]; WERBROUCK in *Bull. Mus. Roy.* 3 Sér. iii (1931), fig. 3, p. 155; CAPART, *L'Art ég.* ii (1942), pl. 207; *Encycl. phot. Caire*, pl. 66; DRIOTON and SVED, *Art ég.* fig. 7; HORNEMANN, *Types*, iv, pl. 1138a (as diorite). See *Descr. somm.* No. 6050.

Base or altar with lions' heads, in Cairo Mus. JE 52519. FIRTH [etc.], *Step Pyr.* ii, pls. 56, cf. 51 [1]; i, p. 66; *id.* in *Ann. Serv.* xxvi (1926), fig. 2, p. 100; PIJOÁN, *Summa Artis*, iii (1945), figs. 100-1; HORNEMANN, *Types*, vii, pl. 1907. Details, CAPART, *Documents*, ii, pl. 37. See *Descr. somm.* No. 6143.

GREAT SOUTH COURT.

FIRTH [etc.], *Step Pyr.* i, pp. 70-1; LAUER, *Pyr. à deg.* i, pp. 178-9 with figs.; *id.* *Hist. mon.* i, pp. 115-17. Views of B-shaped buildings and altar, FIRTH [etc.], *Step Pyr.* ii, pls. 72 [upper], 73; LAUER, *Pyr. à deg.* ii, pls. 1, liii [1]; *id.* in *Ann. Serv.* xxxix (1939), pls. lxvi, lxvii, pp. 448-52; of altar, *id.* *Hist. mon.* i, pl. liv [1]; HOFFMANN in *A. J. A.* 57 (1953), pl. 55 [2] (from FIRTH), p. 190.

Boundary-stelae with names of the King, Hetepḥernebti  and Intkaes , King's daughters, and *imiut*-fetish, in fragments (about 40 inscribed), re-used. Reconstruction, LAUER, *Pyr. à deg.* i, figs. 209, cf. 210, pp. 187-9 (texts). One, in Chicago, Or. Inst. 13652, FIRTH [etc.], *Step Pyr.* ii, pl. 87 [6]; GUNN MSS. xii. 12 [2] (photo.). Another, in Neuchâtel Mus. Eg. 324, FIRTH [etc.], *op. cit.* pl. 87 [5]; GUNN MSS. xii. 11 [2] (photo.). Two, in Cairo Mus. JE 52508-9, see GUNN in *Ann. Serv.* xxix (1929), p. 92; one, FIRTH [etc.], *op. cit.* pl. 87 [1]; *id.* in *Ann. Serv.* xxv (1925), pl. iv [2], p. 149; CAPART, *Memphis*, fig. 90. Some, in Cairo Mus. Temp. Nos. 31.3.33.40-3. Others, FIRTH [etc.], *op. cit.* ii, pl. 87 [2-4]; i, p. 119; GUNN MSS. xii. 11 [3, 4], 12 [1, 3, 4], 13, 14 (photos.); B.3.5, 6 (tracings).

SOUTH TOMB WITH CHAPEL.

FIRTH [etc.], *Step Pyr.* i, pp. 18–20, 54–64; LAUER, *Pyr. à deg.* i, pp. 94–112 with figs.; iii, pp. 46–8; id. *Hist. mon.* i, pp. 117–42 with figs.; id. in *B.I.F.A.O.* xxx (1930), pp. 357–8. Plans and sections, FIRTH [etc.], *Step Pyr.* ii, pls. 47–8; LAUER, *Pyr. à deg.* ii, pls. xxxi, xlix; id. *Hist. mon.* i, plan 20. Plan, id. in *Ann. Serv.* xxx (1930), pl. iii, pp. 143–6 with fig. 4. Reconstruction (model) and section, id. in *B.I.F.A.O.* lv (1955), pl. i, pp. 159, 165–6. Reconstruction, SMITH (E. B.), *Egyptian Architecture as Cultural Expression*, pl. xiv [5]. Views (some restored) of superstructure and chapel, some showing Enclosure Wall,¹ FIRTH [etc.], *Step Pyr.* ii, pls. 31, 72; id. in *Ann. Serv.* xxviii (1928), pl. i [1], pp. 85–7; LAUER, *Pyr. à deg.* ii, pls. 1 [1], li [1]; iii, pl. xxiv, p. 76; id. in *Ann. Serv.* xxxix (1939), pls. lxxii, lxxiii, pp. 470–2 with fig. 45; id. *Les Pyramides de Sakkarah* (1972), figs. 53–4, p. 13; *I.L.N.* Nov. 12, 1927, fig. on p. 861 [lower left]; DRIOTON and LAUER, *Sakkarah* (1939), figs. 16, 17; (1951), figs. 16, 17, on 13. Details, LAUER, *Pyr. à deg.* ii, pl. liv.

Reconstruction of east façade¹ with frieze with uraei, FIRTH [etc.], *Step Pyr.* ii, pl. 49 [2]; LAUER, *Pyr. à deg.* ii, pl. lii. View, id. *Hist. mon.* i, pl. xx; id. in *I.L.N.* March 27, 1948, fig. 10, p. 361; id. in *Bull. Inst. Ég.* xxxviii [1] (1955–6), pl. v, p. 23; id. in *Archaeology*, 10 (1957), fig. 8, p. 278; id. *Saqqara*, pl. 95; LANGE, *Ägypten. Landschaft*, pl. 39; id. and HIRMER, *Ägypten. Architektur* (1955 and 1957), pl. 12; (1967), pl. 14; DRIOTON and SVED, *Art ég.* figs. 4, 5; PANE in *Museum*, iii (1950), figs. 35, cf. 34, pp. 30–1; SAINTE FARE GARNOT, *L'Égypte*, fig. on p. 74 [left]; VIOLLET and DORESE, *Égypt*, pl. 48; BADAWY, *A History of Egyptian Architecture*, i, pl. iv [a]; WOLF, *Die Welt der Ägypter*, Taf. 6 [upper]; DE CENIVAL, *Living Architecture: Egyptian*, pl. 27; MICHAŁOWSKI, *Piramidy i mastaby*, pls. 6, 7.

Views of trench, central shaft, south magazine, etc., FIRTH [etc.], *Step Pyr.* ii, pls. 35–7, 46; LAUER, *Pyr. à deg.* ii, pls. xxxii, xxxiii; id. *Hist. mon.* i, pls. xxi, xxii; id. *Les Pyramides de Sakkarah* (1972), figs. 52, 56–7, pp. 13–14; id. *Mystère*, pl. 9 [b]; id. *Saqqara*, pl. 97; DRIOTON and LAUER, *Sakkarah*, figs. 15, 18–20; CAPART, *Memphis*, figs. 99, 101, 105.

Graffito on exterior wall, probably temp. Ramesses II. GUNN MSS. xii. 6 (photo.); B.3.1 (tracing); transcription, xv. 2.4; translation, FIRTH [etc.], *Step Pyr.* i, p. 85.

Vestibule. P of Lauer.

View of east wall with imitation of barred doors, LAUER, *Pyr. à deg.* ii, pl. xxxvii [4]; id. *Hist. mon.* i, pl. xxiii; id. in *Bull. Soc. fr. d'Ég.* No. 18 (July 1955), fig. 2, p. 35; id. in *Ann. Serv.* liv (1957), pl. iv, pp. 105–6 [C]; id. *Saqqara*, pl. 101.

Tiled rooms.

View, FIRTH [etc.], *Step Pyr.* ii, pls. 38–9, 45 [1, 2]; id. in *Ann. Serv.* xxvii (1927), pl. i, p. 108; LAUER, *Pyr. à deg.* ii, pl. xxxiv; id. *Hist. mon.* i, pl. xxiv; id. *Problème*, pl. xi [1]; id. *Mystère*, pl. 7; id. *Les Pyramides de Sakkarah* (1972), figs. 58–9, p. 14; id. *Saqqara*, pl. 99; *I.L.N.* Nov. 12, 1927, fig. on p. 861 [upper left]; CAPART, *Memphis*, fig. 102; PARIBENI, *Architettura*, fig. 43; DRIOTON and LAUER, *Sakkarah*, figs. 21–2; GALASSI, *Tehemu*, fig. 55; FAKHRY, *The Pyramids*, fig. 13; VANDERSLEYEN, *Das Alte Ägypten*, Abb. 21.

Room I with zad-panels.

Tiled doorway set in *zad*-panel. Reconstruction¹ (painting by Mrs. Firth), FIRTH [etc.], *Step Pyr.* i, frontispiece; id. in *Ann. Serv.* xxvii (1927), pl. ii, p. 109; *I.L.N.* Nov. 12, 1927, fig. on p. 861 [lower right]; Jan. 7, 1928, fig. on p. 9; SCHÄFER and ANDRAE, *Kunst* (1930 and 1942), 211; upper part, HERMANN in *Ä.Z.* 73 (1937), Taf. viii [b], p. 68.

¹ Selected references.

Room II with stelae.

LAUER in *Mon. Piot*, xlix (1957), pp. 1-15; texts, FIRTH in *Ann. Serv.* xxvii (1927), p. 109; xxviii (1928), p. 87.

South stela, King in White Crown. FIRTH [etc.], *Step Pyr.* ii, pls. 40, 44 [2]; LAUER, *Hist. mon.* i, pls. xxv [1], xxviii [1], fig. 54 [B]; id. in *Mon. Piot*, xlix (1957), fig. 3, p. 3; DRIOTON and LAUER, *Sakkarah* (1939), figs. 26, 57; (1951), figs. 26, 58. Head, LAUER, *Les Pyramides de Sakkarah* (1972), fig. 49, p. 14. Shrine, id. *Pyr. à deg.* ii, pl. xxxvii [2].

Central stela, King in Red Crown. FIRTH [etc.], *Step Pyr.* ii, pl. 41; LAUER, *Hist. mon.* i, pls. xxv [2], xxvii [1], fig. 54 [C]; id. in *Mon. Piot*, xlix (1957), pl. ii [1], fig. 11, pp. 1, 14; id. *Les Pyramides de Sakkarah* (1972), fig. 62, p. 14; *I.L.N.* Nov. 12, 1927, fig. on p. 861 [upper right]. Shrine, LAUER, *Pyr. à deg.* ii, pl. xxxvii [3]. See GARDINER in *J.E.A.* 30 (1944), p. 32, cf. pl. iii [3] (from FIRTH).

North stela, King in White Crown running. FIRTH [etc.], *Step Pyr.* ii, pls. 42, 44 [3]; id. in *Ann. Serv.* xxvii (1927), pl. iii, pp. 108-9; LAUER, *Pyr. à deg.* ii, pl. xxxv; id. *Hist. mon.* i, pls. xxvi [2], xxviii [2]; id. *Problème*, pl. xi [2]; id. *Mystère*, pl. 8; id. in *Mon. Piot*, xlix (1957), pl. i [1], cf. fig. 4, pp. 1-3, 14; id. *Les Pyramides de Sakkarah* (1972), figs. 48, 63, p. 14; id. *Saqqara*, pl. xii; DRIOTON and LAUER, *Sakkarah* (1939), figs. 27, 56; (1951), figs. 27, 57; GALASSI, *Tehenu*, fig. 87; id. *L'arte del più antico Egitto* [etc.] in *Rivista dell'Istituto Nazionale d'Archeologia* [etc.], n.s. iv (1955), fig. 77, p. 74; id. in *Critica d'Arte*, n.s. ii (1955), fig. 239, pp. 304, 309; BYVANCK, *De Kunst*, pl. xx [74]; LANGE and HIRMER, *Aegypten. Architektur* (1955 and 1957), pls. 14, 15; (1967), pl. 15; WOOD and DROWER, *Egypt in Colour*, pl. 7; FAVRE, *L'Arte*, fig. on p. 69; SOGA, *The Nile*, fig. on p. 56 [left]; POULSEN, *Åg. Kunst. A. und M.* pl. on p. 37; TOUNY and WENIG, *Sport*, Taf. 62; GROENEWEGEN-FRANKFORT and ASHMOLE, *Art of the Ancient World*, fig. 14; MÜLLER (H. W.) in *Encyclopedia of World Art*, iv, pl. 334 [left]; VANDERSLEYEN, *Das Alte Ägypten*, Abb. 240. Upper part, MENDELSSOHN, *The Riddle of the Pyramids*, pl. 46. Head, BORCHARDT in *Ann. Serv.* xxviii (1928), Bl. 3 [3], p. 49. Lintel and jambs with names, FIRTH [etc.], *Step Pyr.* ii, pl. 43; LAUER, *Pyr. à deg.* ii, pl. xxxvi; id. *Hist. mon.* i, pls. xxvii [2, 3], cf. xxvi [1]; id. in *Mon. Piot*, xlix (1957), figs. 1, 9, pp. 3, 11; id. *Les Pyramides de Sakkarah* (1972), figs. 60-1, p. 14; id. *Saqqara*, pl. 100; DRIOTON and LAUER, *Sakkarah*, figs. 23-5; FAKHRY, *The Pyramids*, fig. 14.

WEST MOUND WITH GALLERIES.

FIRTH [etc.], *Step Pyr.* i, pp. 17, 71-2; LAUER, *Pyr. à deg.* i, pp. 180-3, with plan of galleries, fig. 206; id. *Hist. mon.* i, pp. 142-4. View, FIRTH [etc.], *Step Pyr.* ii, pl. 92 [1].

HEB-SED COMPLEX.**Court.**

FIRTH [etc.], *Step Pyr.* i, pp. 10-13, 67-9; LAUER, *Pyr. à deg.* i, pp. 130-45 with figs.; id. *Hist. mon.* i, pp. 144-8; id. in *B.I.F.A.O.* xxx (1930), pp. 346-9. Plan, id. in *Ann. Serv.* xxviii (1928), pl. i, pp. 95-112. Plan, sections, and reconstruction of chapels, id. *Pyr. à deg.* ii, pls. lv, lvii-lix. Plan, and reconstruction of chapels, FIRTH [etc.], *Step Pyr.* ii, pls. 67-8. Plan of chapel, id. in *Ann. Serv.* xxv (1925), fig. 1, p. 155; reconstruction of chapels, LAUER in *Ann. Serv.* xxviii (1928), pls. iv, v, pp. 96-8; id. in *R.E.A.* iii (1931), pl. vi, p. 13; SCHÄFER and ANDRAE, *Kunst* (1942), 209 [upper]; DRIOTON and LAUER, *Sakkarah*, fig. 37; LAUER, *Les Pyramides de Sakkarah* (1972), fig. 18, p. 8.

Views¹ of court, FIRTH [etc.], *Step Pyr.* ii, pls. 60-1, 62 [1, 2]; id. in *Ann. Serv.* xxv (1925), pls. i [2], ii [1], pp. 155-7; id. in *R.E.A.* iii (1931), pl. iii, p. 6; LAUER, *Pyr. à deg.* ii, pls. lvi, lxii, lxiii [1], lxiv, lxv [1, 2], lxvi, lxvii, xcii (with details); id. *Hist. mon.* i, pls. xxix, xxx, plans 22, 23 [b], figs. 37-8 (with details and reconstructions); id. *Les Pyramides de Sakkarah* (1972), fig. 17, pp. 8-9; id. *Mystère*, pl. iv [a]; id. *Saqqara*, pls. 110-11; BAIKIE, *Eg. Antiq.* pl. iv [upper]; PARIBENI, *Architettura*, fig. 27; BORCHARDT and RICKE, *Egypt*, pl. 93; DRIOTON and LAUER, *Sakkarah*, fig. 36; HAMANN, *Äg. Kunst*, Abb. 108-9; GIEDION, *The Eternal Present*, ii, pl. vi; DRIOTON and DU BOURGUET, *Pharaons*, pl. 9; VERCOUTTER, in *Die Alt-orientalischen Reiche*, i (*Fischer Weltgeschichte*, 2), Abb. 28 on p. 253; VANDERSLEYEN, *Das Alte Ägypten*, Abb. i; LECLANT in *Orientalia*, n.s. 43 (1974), pls. ix-x [12, 13], pp. 180-1 [d]; 44 (1975), pl. xii [2], p. 205 [d].

Imitation in stone of elements of chapels, LAUER, *Pyr. à deg.* ii, pls. lx, lxi, lxiii [2, 3], lxv [3], xcvi [1]; DRIOTON and LAUER, *Sakkarah*, figs. 33-5; LAUER, *Les Pyramides de Sakkarah* (1972), figs. 21-3, p. 8. Open door, MURRAY, *Egyptian Temples*, pl. iv [2]; GIEDION, op. cit. fig. 166. Stake fence, FIRTH [etc.], *Step Pyr.* ii, pl. 62 [3]; i, p. 67; id. in *Ann. Serv.* xxv (1925), pl. iv [3], p. 156; CAPART, *Memphis*, fig. 97; SCHÄFER and ANDRAE, *Kunst* (1930), 210 [lower]; VON BISSING, *Äg. Kunstgeschichte*, Taf. xxix [233, 235], *Text*, i, pp. 53-4; GIEDION, op. cit. fig. 164; SÉE, *Naissance*, fig. on p. 141. Capitals composed of pendant leaves, FIRTH [etc.], *Step Pyr.* ii, pls. 64-5; id. in *Ann. Serv.* xxv (1925), pl. v [1, 2], p. 156; CAPART, *Memphis*, fig. 92; CLARKE and ENGELBACH, *Ancient Egyptian Masonry*, figs. 5, 6; PIJOÁN, *Summa Artis*, iii (1945), fig. 97; LAUER, *Saqqara*, pl. 92.

Pavilion.

Views, LAUER in *Comptes rendus* (1963), p. 303 with fig. 1; (1966), pl. ii [a], p. 454; (1969), pl. i, p. 460; (1970), pl. i [a] facing p. 484; id. in *Bull. Soc. fr. d'Ég.* No. 40 (July 1964), pls. ii, iii, pp. 15-16 [3]; No. 47 (Dec. 1966), pl. i, pp. 21-2; No. 52 (July 1968), pl. iii [A], pp. 16-17; No. 56 (Nov. 1969), pl. i [A], pp. 11-12; id. in *Bull. Inst. Ég.* xlvii (1965-6), pl. iii [a], pp. 33-6; id. in *Ann. Serv.* lxi (1973), pls. viii-xi, xii [b, background], xiii [a], pp. 132-3 [b], 134-5 [b], 136 [b], 137 [a], 138-9 [a], 139-40 [a]; id. *Les Pyramides de Sakkarah* (1972), fig. 19, p. 8; id. *Saqqara*, pl. xiv; LECLANT in *Orientalia*, n.s. 34 (1965), pl. xxix [7], pp. 182-3 [13, a]; 36 (1967), pl. xxv [3], p. 189 [γ]; 37 (1968), pl. xvii [14], p. 105 [β]; 38 (1969), pl. xx [22], p. 255 [β]; 39 (1970), pl. xxvi [18, 19], pp. 331-2 [b]; MICHAŁOWSKI, *Piramidy i mastaby*, pl. 9.

West chapels.

View of Nos. 1-3, LAUER in *Comptes rendus* (1970), pl. i [b], pp. 484, 486; (1972), pl. i [a], pp. 577-8 [1]; id. in *Bull. Soc. fr. d'Ég.* No. 62 (Oct. 1971), fig. on p. 33, cf. pp. 31-4; LECLANT in *Orientalia*, n.s. 40 (1971), pl. xxv [13], p. 232 [f]; of Nos. 2-4, n.s. 42 (1973), pl. ix [10], p. 401 [c]; of No. 2, LAUER in *Ann. Serv.* lxi (1973), pl. xiii [b], pp. 140-1 [b], 142-3 [a]; of No. 4, id. in *Comptes rendus* (1963), figs. 2, 4, 5, cf. 3, pp. 303-8; (1966), pl. i, p. 454; id. in *Bull. Soc. fr. d'Ég.* Nos. 37-8 (Dec. 1963), pl. iv, pp. 35-8; No. 40 (July 1964), pl. i, pp. 14-15 [2]; id. in *Bull. Inst. Ég.* xlvii (1965-6), pls. ii [a], iii [b], pp. 33-6; id. *Les Pyramides de Sakkarah* (1972), fig. 20, pl. 8; id. *Saqqara*, pl. xiii; id. in *Ann. Serv.* lxi (1973), pls. i-vii, pp. 126-32, 133-4 [a], 135 [a]; LECLANT in *Orientalia*, n.s. 32 (1963), pl. viii [3], pp. 86-7 [14, a]; 33 (1964), pl. xxvii [7, 8], pp. 343-4 [14, a]; 34 (1965), pl. xxix [6], p. 182 [13, a]; ALDRED, *Egypt*, fig. 64; WOLDERING, *Götter*, Abb. 14; MÜLLER, *Äg. Kunst*, Abb. 17;

¹ Selected references.

MICHAŁOWSKI, *Piramidy i mastaby*, pl. 2. Detail, GILBERT in *Chron. d'Ég.* xvii (1942), fig. 4, p. 85 [bottom].

Chapel P (of Lauer).

Blocks from colossal royal statue (?). See FIRTH [etc.], *Step Pyr.* i, pp. 68, 130, cf. ii, pl. 95 [17]; SMITH, *Hist. Eg. Sculp.* p. 15 [top].

North pavilion.

Feet of four statues, probably the King, a Queen or god, and two princesses (or Queens). FIRTH [etc.], *Step Pyr.* ii, pl. 63 [2]; i, p. 68; CAPART, *Memphis*, fig. 96; GIEDION, *The Eternal Present*, ii, fig. 168; ANGIOLETTI and BIGONGIARI, *Testimone*, Tav. 27.

East chapels.

One, LAUER in *Comptes rendus* (1970), pl. ii [b], pp. 486, 488 [3]; (1972), pl. i [b], pp. 578-9 [2]; id. in *Bull. Soc. fr. d'Ég.* No. 62 (Oct. 1971), fig. on p. 35, cf. pp. 34-5; id. in *Ann. Serv.* lxi (1973), pls. xiv, xv, pp. 141-2 [d], 143-4 [c]; LECLANT, *Orientalia*, n.s. 40 (1971), pl. xxiv [12], p. 232 [f]; 41 (1972), pl. xvi [15], p. 256 [e]; 42 (1973), pl. x [11], p. 401 [c]; two, LAUER in *Comptes rendus* (1973), pl. ii [b], p. 325.

Osiride caryatids (unfinished). FIRTH [etc.], *Step Pyr.* ii, pl. 66; i, pp. 12, 69; LAUER, *Pyr. à deg.* ii, pl. xcix; i, pp. 144-5, 237 [3]; id. in *Comptes rendus* (1973), pl. ii [a], pp. 324-5; LECLANT in *Orientalia*, n.s. 43 (1974), pl. xi [14], p. 181 [top]; VANDERSLEYEN, *Das Alte Ägypten*, Abb. 16 [a]; GUNN MSS. xii. 17, 18 (photos.); one, ALDRED, *Egypt*, fig. 63.

Ḥeb-sed pavilion.

View, FIRTH [etc.], *Step Pyr.* ii, pl. 63 [1]; i, p. 69; LAUER in *Comptes rendus* (1970), pl. ii [a], p. 486 [2]; (1973), pl. i [a] on p. 333; id. in *Ann. Serv.* lxi (1973), pl. xii [a, b foreground], p. 143 [b]. See id. *Pyr. à deg.* i, p. 145 [C] with plan; BORCHARDT, *Ägyptische Tempel mit Umgang in Beiträge zur ägyptischen Bauforschung und Altertumskunde*, 2, pp. 57-8 with Abb. 20 (from LAUER).

Building with three fluted columns.

FIRTH [etc.], *Step Pyr.* i, pp. 69-70; LAUER, *Pyr. à deg.* i, pp. 145-52 with figs.; id. *Hist. mon.* i, pp. 148-52 with figs.

Plan, FIRTH [etc.], *Step Pyr.* ii, on pl. 67; i, on fig. 9; LAUER, *Études complémentaires* [etc.] in *Ann. Serv. Cahier*, No. 9 (1948), fig. 10, pp. 56-63. Plan, section, and elevation, id. *Pyr. à deg.* ii, on pls. lv, lxx; id. in *Ann. Serv.* xxviii (1928), on pls. i-iii, pp. 90-5. Section, id. in *R.E.A.* iii (1931), pl. vii, p. 14. Section, elevation, and view, id. *Hist. mon.* i, pl. xxxi, plan 24. Reconstruction, id. *Pyr. à deg.* iii, frontispiece; DRIOTON and LAUER, *Sakkarah*, fig. 32.

View,¹ FIRTH [etc.], *Step Pyr.* ii, pls. 69-71; id. in *Ann. Serv.* xxv (1925), pl. ii [2], pp. 157-8; LAUER, *Pyr. à deg.* ii, pls. lxxviii, lxxix, xcii [3]; id. in *Ann. Serv.* xxx (1930), pl. ii, pp. 133-6; xxxi (1931), pl. i, p. 65; id. in *I.L.N.* March 27, 1948, fig. 5, p. 360; id. in *Bull. Inst. Ég.* xxxviii [1] (1955-6), pl. ii, p. 22; id. in *Archaeology*, 10 (1957), fig. 4, p. 278; id. *Les Pyramides de Sakkarah* (1972), figs. 15, 16, pp. 7, 8; id. in *Comptes rendus* (1973), pl. i [b], pp. 325-6; id. *Saqqara*, pls. 84-5; SCHÄFER and ANDRAE, *Kunst* (1930), 210 [upper]; CLARKE and ENGELBACH, *Ancient Egyptian Masonry*, fig. 2; PARIBENI, *Architettura*, figs.

¹ Selected references.

34, 36; DRIOTON and LAUER, *Sakkarah*, figs. 30-1; LANGE, *Äg. Kunst*, pl. 6; id. *Ägypten. Landschaft*, pl. 36; id. and HIRMER, *Aegypten. Architektur*, pl. 13; GALASSI, *Tehenu*, fig. 37; HOYNINGEN-HUENE and STEINDORFF, *Egypt* (1943), fig. on p. 29; (1945), fig. on p. 16; HAMANN, *Äg. Kunst*, Abb. 112; ALDRED, *O.K. Art*, pl. 7; id. *The Egyptians*, pl. 6; DRIOTON and SVED, *Art ég.* fig. 1; PANE in *Museum*, iii (1950), figs. 36-7, p. 32; VANDIER, *Egypt. Paintings from Tombs and Temples*, pl. facing p. 10; SMITH (J. L.), *Tombs, Temples, and Ancient Art*, pl. facing p. 177; LLOYD, *The Art of the Ancient Near East*, fig. 225; DESROCHES-NOBLECOURT, *Egyptian Wall-Paintings from Tombs and Temples*, fig. on p. 11; id. in *L'Amour de l'art*, xxviii, fig. on p. 206; GIEDION, *The Eternal Present*, ii, pl. v; DE CENIVAL, *Living Architecture: Egyptian*, pls. 25, 28 [left]; ANGIOLETTI and BIGONGIARI, *Testimone*, Tav. 30.

Lintel with *zad*-decoration, FIRTH [etc.], *Step Pyr.* ii, pl. 71 [3]; id. in *Ann. Serv.* xxv (1925), pl. v [3], p. 158; LAUER, *Pyr. à deg.* ii, pl. lxxv [4]; GALASSI, *Tehenu*, fig. 56.





SOUTH AND NORTH BUILDINGS. Lepsius, 'Pyramids' XXXIV, XXXIII.

FIRTH [etc.], *Step Pyr.* i, pp. 15-17, 72-6; LAUER, *Pyr. à deg.* i, pp. 154-77 with figs.; id. *Hist. mon.* i, pp. 154-69 with figs.; id. in *B.I.F.A.O.* xxx (1930), pp. 338-46, cf. figs. 3-5. Preliminary plan, FIRTH in *Ann. Serv.* xxiv (1924), fig. 1, p. 122.

Reconstruction of Hathor-capital, BORCHARDT, *Ägyptische Tempel mit Umgang in Beiträge zur ägyptischen Bauforschung und Altertumskunde*, 2, Abb. 8, p. 27.

South Building. 'Maison du Sud'.

Plan, FIRTH [etc.], *Step Pyr.* ii, pl. 82; LAUER, *Pyr. à deg.* ii, pl. lxxi; id. in *Ann. Serv.* xxvii (1927), fig. 1 [lower], pp. 113-21; xxix (1929), pl. iii, pp. 104-8, cf. figs. 10-18. Reconstruction, FIRTH [etc.], *Step Pyr.* ii, pl. 79 A; LAUER, *Pyr. à deg.* ii, pl. lxxiii; iii, pl. xx [2], p. 45; id. *Hist. mon.* i, plan 25 [b]; id. in *Ann. Serv.* xxvii (1927), pl. ii, pp. 113-21; id. in *R.E.A.* iii (1931), pl. v, p. 12; id. *Les Pyramides de Sakkarah* (1972), fig. 29, p. 9; id. *Saqqara*, pl. 93; *I.L.N.* Jan. 7, 1928, fig. 1, p. 8; DRIOTON and LAUER, *Sakkarah* (1939), fig. 44; (1951), fig. 43; SCHÄFER and ANDRAE, *Kunst* (1942), 209 [lower]. Views, FIRTH [etc.], *Step Pyr.* ii, pls. 79-81; id. in *Ann. Serv.* xxiv (1924), pls. ii [2], iii [2], cf. i, pp. 122-7; LAUER, *Pyr. à deg.* ii, pls. lxxii, lxxv [2, 3], lxxvi, lxxvii; id. *Hist. mon.* i, pl. xxxii [1], xxxiii [1]; id. in *Ann. Serv.* xxxvii (1937), pl. iii, pp. 99-100; liv (1957), pls. ii, iii, pp. 104-5 [B]; id. in *I.L.N.* March 27, 1948, figs. 2, 3, p. 360; id. *Les Pyramides de Sakkarah* (1972), figs. 25-7, pp. 9-10; id. *Saqqara*, pl. 94; DRIOTON and LAUER, *Sakkarah* (1939), figs. 40-2; (1951), figs. 39-41; LANGE, *Ägypten. Landschaft*, pl. 38; VIOLETT and DORESSE, *Egypt*, pl. 47.

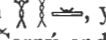
Visitors' graffiti, hieratic, temp. Amenophis I to Ramesside. Hadnakht  Scribe of the Treasury, son of Sunero , with brother Panakht  Scribe of the Vizier, year 47 of Ramesses II; FIRTH [etc.], *Step Pyr.* ii, pl. 83 [2, 3]; i, pp. 82-3 [S] (by Černý and Gunn); DRIOTON and LAUER, *Sakkarah* (1939), fig. 43; (1951), fig. 42; LAUER, *Les Pyramides de Sakkarah* (1972), fig. 28, pp. 9-10; id. *Saqqara*, pl. 79; GUNN MSS. xii. 1-4 [upper] (photos.); B.2.S; transcription, ČERNÝ Notebook, 13, p. 6; GUNN MSS. xiii. 4. 12 [upper]. Son of Hori, and Thay  son of Wah , year 48 of Ramesses II; FIRTH [etc.], *Step Pyr.* ii, pl. 83 [1]; i, pp. 83-4 [T] (by Černý and Gunn); GUNN MSS. xii. 4 [lower]-5 (photos.); B.2.T; transcription, ČERNÝ Notebook, 13, pp. 3, 7; GUNN MSS. xiii. 4. 11 [upper], 13 [upper right]. Amenemhët, Dyn. XVIII (?); GUNN MSS. B.2.N; transcription and translation by Černý and Gunn, FIRTH [etc.], *Step Pyr.* i, pp. 81-2 [N]; transcription, ČERNÝ Notebook, 13, p. 4 [upper]; GUNN MSS. xiii. 4. 8 [top]. Others, GUNN MSS. B.2 (without I, L, M, O of FIRTH), Notebook, 31, pp. 45-50, 72-9 (with sketch-plan); some, xii. 7-8 (photos.); translations,

FIRTH [etc.], *Step Pyr.* i, pp. 79–85 (Gunn); transcriptions, GUNN MSS. xiii. 4 (without B, O, R, X); of Q, KITCHEN, *Ram. Inscr.* i. 237 [106, i] (from GUNN MSS.); V, ČERNÝ Notebook, 13, p. 4 [lower]; F (first three lines), p. 5.

North Building. 'Maison du Nord'.

Plan, FIRTH [etc.], *Step Pyr.* ii, pl. 78; LAUER, *Pyr. à deg.* ii, pl. lxxviii; id. in *Ann. Serv.* xxvii (1927), fig. 1 [upper], pp. 113–21; xxix (1929), pl. iv, pp. 108–18, cf. figs. 19–27. Reconstruction, FIRTH [etc.], *Step Pyr.* ii, pl. 77; LAUER, *Pyr. à deg.* ii, pl. lxxxi; iii, pl. xx [1], pp. 43–5 with figs.; id. *Hist. mon.* i, plan 25 [a], fig. 49; id. in *Ann. Serv.* xxvii (1927), pl. i, pp. 113–21; xxviii (1928), pl. vi, p. 113; id. *Les Pyramides de Sakkarah* (1972), fig. 37, p. 11; *I.L.N.* Jan. 7, 1928, fig. 2, p. 8; DRIOTON and LAUER, *Sakkarah* (1939), fig. 64; (1951), fig. 65; SCHOTT in *Göttingische gelehrte Anzeigen*, 218 (1966), Abb. 4 (by Ricke), p. 301.

View from the Pyramid, LAUER, *Pyr. à deg.* ii, pl. lxxxiv; id. *Hist. mon.* i, pl. xxxiv [1]; *I.L.N.* Oct. 4, 1924, fig. on p. 631; Oct. 18, 1924, figs. 1, 3–5, cf. 6, pp. 726–7; CAPART in *Chron. d'Ég.* ii (1926–7), fig. on p. 124; PARIBENI, *Architettura*, fig. 13. Views,¹ FIRTH [etc.], *Step Pyr.* ii, pls. 74–6; id. in *Ann. Serv.* xxiv (1924), pls. ii [1], iii [1], cf. i, pp. 122–7; id. in *Antiquity*, ii (1928), pl. iii (entrance), p. 461; id. in *R.E.A.* iii (1931), pl. iv, fig. 2, p. 8; LAUER, *Pyr. à deg.* ii, pls. lxxv [1], lxxix, lxxx, lxxxv, lxxxvi, cf. pls. lxxxviii [2], xcii [1]; id. *Hist. mon.* i, pl. xxxii [2], cf. pl. xxxiv [2]; id. in *Ann. Serv.* xxxvii [1937], pl. i, pp. 97–9; id. in *Bull. Inst. Ég.* xxxviii [1] (1955–6), pl. iii, p. 22; id. in *Archaeology*, 10 (1957), fig. 7, pp. 278–9; id. *Les Pyramides de Sakkarah* (1972), figs. 35–6, 38, p. 11; id. *Saqqara*, pl. 78; STEINDORFF, *Kunst*, 108; CLARKE and ENGELBACH, *Ancient Egyptian Masonry*, fig. 1; CAPART, *Memphis*, figs. 88–9; id. *Propos*, fig. 7; SCHÄFER and ANDRAE, *Kunst* (1930), 209 [lower]; BAIKIE, *Eg. Antiq.* pl. iv [lower]; PARIBENI, *Architettura*, fig. 38; BORCHARDT and RICKE, *Egypt*, pl. 91; SCHARFF in OTTO, *Handbuch der Archäologie*, i, Taf. 59 [2], p. 467; DRIOTON and LAUER, *Sakkarah* (1939), figs. 62–3, 65; (1951), figs. 63–4, 66; LANGE, *Äg. Kunst*, pl. 9; GALASSI, *Tehenu*, fig. 39; GILBERT, *Le Classicisme de l'architecture égyptienne*, fig. 2; HAMANN, *Äg. Kunst*, Abb. 113; PIJOÁN, *Summa Artis*, iii (1945), fig. 96.

Engaged papyrus columns,¹ in east wall of court. Reconstruction, LAUER, *Pyr. à deg.* ii, pl. lxxxiii; id. in *Ann. Serv.* xxix (1929), pl. vi [1], p. 110. Views, id. *Pyr. à deg.* ii, pls. lxxxii, cf. lxxxviii [1]; id. ib. iii, pl. xxiii; id. *Hist. mon.* i, pl. xxxiii [2]; id. in *Ann. Serv.* xxxvii (1937), pl. ii, pp. 97–9; id. in *I.L.N.* March 27, 1948, fig. 8, p. 361; id. in *Bull. Inst. Ég.* xxxviii [1] (1955–6), pl. iv, p. 22; id. in *Archaeology*, 10 (1957), fig. 6, p. 278; id. *Les Pyramides de Sakkarah* (1972), fig. 39, p. 12; DRIOTON and LAUER, *Sakkarah* (1939), fig. 66; (1951), fig. 67; LANGE, *Äg. Kunst*, pl. 7; id. and HIRMER, *Aegypten. Architektur* (1955 and 1957), pl. 8; (1967), pl. 12; DRIOTON and SVED, *Art ég.* fig. 6; VIOLLET and DORESSE, *Égypt*, pl. 46; EDWARDS, *Pyramids* (1961), pl. 5 [a]; DE CENIVAL, *Living Architecture: Egyptian*, pl. 29; MONTET, *Lives of the Pharaohs*, fig. on p. 12 [left]; POULSEN, *Äg. Kunst. A. und M.* pl. on p. 34; WOLF, *Hochkulturen*, Abb. 3. One, HOYNINGEN-HUENE and STEINDORFF, *Egypt* (1943), fig. on p. 7; (1945), fig. on p. 19; CLARKE and ENGELBACH, *Ancient Egyptian Masonry*, fig. 7; GIEDION, *The Eternal Present*, ii, pl. i.

Visitors' graffiti, hieratic and hieroglyphic, Dyn. XVIII to Necho II. Setemḥab , Scribe of the school, and 'Aḥmosi, Dyn. XVIII; GUNN MSS. B.1.A; xii. 23 [upper], 25 (photos.); transcription and translation, FIRTH [etc.], *Step Pyr.* i, p. 78 [A] (by Černý and Gunn); transcription, ČERNÝ Notebook, 13, p. 1; GUNN MSS. xiii. 5. 2 [lower]. Others, GUNN MSS. B.1.B–H; xii. 23 [lower] (possibly), 24 (B and D of Firth) (photos.);

¹ Selected references.

Notebook, 31, pp. 51-4; translations, FIRTH [etc.], *Step Pyr.* i, pp. 78-9 (Gunn); transcription of B, Thay, temp. Tutankhamûn, ČERNÝ Notebook, 13, p. 2; of B, C, D, H, GUNN MSS. xiii. 5. 1, 2 [upper].

SERDAB COURT.

FIRTH [etc.], *Step Pyramid* i, pp. 9, 50-1; LAUER, *Pyr. à deg.* i, pp. 78-9; id. *Hist. mon.* i, pp. 169-71. Plan, FIRTH [etc.], *Step Pyr.* ii, on pl. 27; LAUER, *Pyr. à deg.* ii, on pl. xxii; id. in *Ann. Serv.* xxix (1929), on pl. v [lower], pp. 119-20; id. in *B.I.F.A.O.* xxx (1930), on pl. ii, p. 356; of north part, id. in *Ann. Serv.* xxx (1930), pl. ii, pp. 140-3.

Views of serdab, some with statue *in situ*, FIRTH [etc.], *Step Pyr.* ii, pls. 24 [2], 28; LAUER, *Pyr. à deg.* ii, pls. xxi [2], xxiii [1], cf. xcii [2]; id. *Hist. mon.* i, pl. xiii; id. *Les Pyramides de Sakkarah* (1972), fig. 32, p. 11; id. *Saqqara*, pls. 81-2; *I.L.N.* Feb. 28, 1925, fig. on p. 337 [lower]; CAPART, *Memphis*, fig. 98; SMITH (E. B.), *Egyptian Architecture as Cultural Expression*, pl. xix [3, 4]; DRIOTON and LAUER, *Sakkarah* (1939), fig. 45; (1951), fig. 46; SHOUKRY, *Privatgrabstatue*, Abb. 41; MENDELSSOHN, *The Riddle of the Pyramids*, pl. 10.

Statue¹ of Neterikhet (Zoser) seated, in Cairo Mus. JE 49158. FIRTH [etc.], *Step Pyr.* ii, pls. 29, 30; i, pp. 9, 51; id. in *Ann. Serv.* xxv (1925), pls. iv [1], cf. iii, pp. 149-50; LAUER, *Pyr. à deg.* ii, pl. xxiv; id. *Hist. mon.* i, pl. xxviii [lower right], xxxv [1, 2]; id. *Les Pyramides de Sakkarah* (1972), figs. 33-4, p. 11; id. *Mystère*, pl. 9 [a]; id. *Saqqara*, pl. 80; STEINDORFF, *Kunst*, 173; SCHÄFER and ANDRAE, *Kunst* (1930 and 1942), 228-9; ROSS, *The Art of Egypt*, pl. on p. 99 [3]; VON BISSING, *Äg. Kunstgeschichte*, Taf. 1, *Text*, i, pp. 40, 185; ii, p. 140 note 6; SCHÄFER, *Das altägyptische Bildnis*, Taf. 2; DRIOTON and LAUER, *Sakkarah* (1939), figs. 46-7, 59; (1951), figs. 47-8, 60; LEBOVITCH, *Anc. Eg.* fig. 54; CAPART, *L'Art ég.* ii, pls. 208-9; HAMANN, *Äg. Kunst*, Abb. 114, 114a; PIJOÁN, *Summa Artis*, iii (1945), figs. 102-4; SMITH, *Hist. Eg. Sculp.* pl. 2 [c], pp. 13-14; id. *Art . . . Anc. Eg.* pl. 15 [A], p. 30; MITRY, *Illus. Cat.* No. 6008; EDWARDS, *Pyramids* (1947), pl. 3b; (1961), pl. 4; ALDRED, *O.K. Art.* pl. 6; LANGE and HIRMER, *Aegypten. Architektur*, pls. 16, 17; DONADONI, *Arte Egizia*, figs. 12, 13; RIAD, *La Médecine au temps des pharaons*, fig. 27; HORNEMANN, *Types*, iii, pls. 752-3; WOLF, *Kunst*, Abb. 88; PIRENNE, *Hist. civ.* i, pls. 14, 15 between pp. 60-1; FAKHRY, *The Pyramids*, fig. 16; WOLDERING, *Götter*, Abb. 15; WESTENDORF, *Das Alte Ägypten*, fig. on p. 30; MICHALOWSKI, *Art*, figs. 39, 184; *Great Museums*, pl. 5, fig. on p. 43. Upper part, CAPART, *Memphis*, fig. 131; id. *Documents*, ii, pls. 6, 32 [A] (base); LANGE, *Äg. Kunst*, pl. 10; ANTHES, *Meisterwerke*, Taf. xxx; id. *Aeg. Plastik*, Taf. 36; STEINDORFF, *A Royal Head*, pl. 6, p. 8 [17]; PRITCHARD, *Anc. Near East*, fig. 376; MÜLLER, *Äg. Kunst*, Abb. 15. See *Descr. somm.* No. 6008.

Boundary-stelae with names of the King, Hetephernebti and Intkaes, and *imiut*-fetish, about 60 fragments, re-used. FIRTH [etc.], *Step Pyr.* ii, pl. 86; i, p. 119; LAUER, *Pyr. à deg.* i, pp. 189-90 with fig. 211; GUNN MSS. xii. 11 [1] (photo).

AREA BETWEEN MORTUARY TEMPLE AND NORTH ENCLOSURE WALL.

FIRTH [etc.], *Step Pyr.* i, pp. 8, 77; id. in *Ann. Serv.* xxvii (1927), pp. 107-8; LAUER, *Pyr. à deg.* i, pp. 175-7, 183-6; id. *Hist. mon.* i, pp. 105-9. View of magazines against north wall, FIRTH [etc.], *Step Pyr.* ii, pl. 85; LAUER, *Hist. mon.* i, pl. xv [2].

Altar. FIRTH [etc.], *Step Pyr.* ii, pl. 84; LAUER, *Pyr. à deg.* ii, pl. lxxxvi [2]; id. *Hist. mon.* i, pl. xv [1]; HOFFMANN in *A.Ĵ.A.* 57 (1953), pl. 55 [3, 3a], p. 190.

¹ Selected references.

Galleries along north enclosure wall.

Plan, LAUER, *Pyr. à deg.* i, fig. 208; id. *Hist. mon.* i, fig. 32; id., TÄCKHOLM and ÅBERG in *Bull. Inst. Ég.* xxxii (1949-50), fig. 1, p. 123.

Sealings of Kha-sekhemui and Neterikhet. LACAU and LAUER, *Pyr. à deg.* v, figs. 179-86, p. 98; FIRTH [etc.], *Step Pyr.* i, figs. 19-22, pp. 141-2; cf. LAUER, *Hist. mon.* i, p. 107 note 2.

Galleries of Mariette. 'Tomb' No. 86 [A 4], in north-west corner.

MARIETTE, *Mastabas*, pp. 83-6, with plans and sketches.

Two lion embalming-tables, alabaster, probably Late Period, in Cairo Mus. CG 1321-2. BORCHARDT, *Denkmäler*, Bl. 3, pp. 9-10; see MASPERO, *Guide*, p. 59 [119]. CG 1321, VON BISSING, *Denkmäler, Text*, fig. on p. vii [left]; id. *Äg. Kunstgeschichte*, Taf. lxxvii [406a, b], *Text*, i, p. 41; DE ROUGÉ, *Album photo.* 99; SCHARFF in OTTO, *Handbuch der Archäologie*, i, Taf. 75 [5], p. 521; CAPART, *L'Art ég.* iv, pl. 610; *Encycl. phot. Caire*, pl. 4; VANDIER, *Manuel*, ii, fig. 308 [bottom right], p. 524; *Great Museums*, fig. on p. 229 [2]. CG 1322, BORCHARDT in *Ä.Z.* xxxvi (1898), Abb. 3, p. 6; TARCHI, *L'Architettura*, Tav. 8 [right lower]; PIJOÁN, *Summa Artis*, iii (1945), fig. 74 (probably this); Stockholm. 5000 år, No. 18 with fig.; Amsterdam. 5000 jaar, frontispiece i [6]; Louisiana. 5000 års, No. 52 with fig.; Brussels. 5000 ans, fig. 6, p. 21 [3]; Zürich. 5000 Jahre, Abb. 29, p. 57 [104]; Vienna. 5000 Jahre, No. 10 with Abb.; Essen. 5000 Jahre, No. 22 with Abb.; London. 5000 Years, pl. iv [lower], p. 13 [16]; HORNE-MANN, *Types*, vii, pl. 1748; DE MEULENAERE, *Het leven na de dood in het Oude Egypte* (Tentoonstelling van 21 juni tot 28 september 1969. Provinciaal Gallo-Romeins Museum—Tongeren), No. 26 with pl. 9.

Various finds from the Step Pyramid enclosure

Fragments of statues, including some from statue similar to one in serdab, possibly from another serdab. FIRTH [etc.], *Step Pyr.* ii, pl. 95; i, pp. 9, 51, 129-30.

Two heads of captives, now separate, schist, Dyn. III, in Cairo Mus. Temp. No. 18.2.26.5. Id. ib. ii, pl. 57 [2, 3]; i, pp. 75, 113; one, *Chron. d'Ég.* i (1925-6), fig. on p. 81; ENGELBACH in *Ann. Serv.* xxviii (1928), pl. i [2], p. 16. See *Descr. somm.* No. 6050.

D. STEP PYRAMID ENCLOSURE OF SEKHEMKHET

𓆎. Dyn. III

GONEIM, *Horus Sekhem-khet*, i (hereafter GONEIM); id. *The Buried Pyramid*; id. in *Bull. Inst. Ég.* xxxvi (1953-4), pp. 559-81 with figs.; id. in *La Revue du Caire*, xxxiii, No. 175 (1955), pp. 18-31 with figs.; LAUER, *Hist. mon.* i, pp. 179-206 with plates, plan, and figs.; id. in *Bull. Inst. Ég.* xxxvi (1953-4), pp. 357-64; id. in *Bull. Soc. fr. d'Ég.* No. 18 (July 1955), pp. 27-34; No. 22 (Nov. 1956), pp. 53-6; MARAGIOGLIO and RINALDI, *L'Architettura*, ii, pp. 11-39, cf. 51-2, with Tav.; H. BR[UNNER] in *Archiv für Orientforschung*, xvii (1954-6), pp. 474-5.

Position, GONEIM, pl. ii; see also plans showing position of Royal Tombs of Dyn. II, *infra*. Plans, sections, reconstructions, id. ib. pls. iii-v; MARAGIOGLIO and RINALDI, *L'Architettura*, ii, Tav. 2-5. Plan, GONEIM, *The Buried Pyramid*, fig. on p. 103; cf. id. in *Bull. Inst. Ég.* xxxvi (1953-4), fig. 2 on p. 561; and section of Pyramid, LAUER, *Mystère*, figs. 27-8.

Vertical aerial view, GONEIM, on pl. i; id. *The Buried Pyramid*, on fig. 10; id. in *Bull. Inst. Ég.* xxxvi (1953-4), on fig. 1 on p. 560; LAUER, *Hist. mon.* i, on pl. xxxvi. View of foundation platform, GONEIM, pl. vii; LAUER in *Bull. Soc. fr. d'Ég.* No. 40 (July 1964), pl. iv, p. 17.

STEP PYRAMID. Unfinished.

Plan, LAUER, *Observations sur les pyramides*, fig. 18, pp. 76–80; id. in *Bull. Soc. fr. d'Ég.* No. 18 (July 1955), fig. 1, pp. 27–34; id. in *Rev. Arch.* 6 Sér. xlvii (1956), fig. 8, pp. 10–14; plan and section, id. *Hist. mon.* i, plan 26; id. *Les pyramides de Sakkarah* (1972), figs. 72–3, pp. 15–16.

Exterior. GONEIM, pp. 6, 8–11.

Views, mainly of corners, id. ib. pls. xiv–xix, fig. 25; id. in *Bull. Inst. Ég.* xxxvi (1953–4), figs. 4, 5 on pp. 566, 568; id. in *La Revue du Caire*, xxxiii, No. 175 (1955), fig. 21; LECLANT in *Orientalia*, n.s. 25 (1956), pl. xl [9], pp. 256–7 [B, b]; LAUER in *Rev. Arch.* 6 Sér. xlvii (1956), fig. 6, p. 10; id. *Saqqara*, pl. 113; MENDELSSOHN, *The Riddle of the Pyramids*, pl. 12.

Boundary-stela of Neterikhet, re-used. GONEIM, fig. 26, p. 8; see LECLANT in *Orientalia*, n.s. 23 (1954), p. 69 [a].

Interior. GONEIM, pp. 11–22.

Views of open trench with descending corridor and vertical shaft, id. ib. pls. xix bis–xxiii, xxvii–xxviii bis, xlix, l, lxi–lxiv; id. *The Buried Pyramid*, figs. 27–34, 44–6; id. in *Bull. Inst. Ég.* xxxvi (1953–4), figs. 6–8 on pp. 569, 570, 572; id. in *La Revue du Caire*, xxxiii, No. 175 (1955), figs. 22–3; *Egypt Trav. Mag.* (Special Issue 1954), fig. on p. 64 [upper]; DESROCHES NOBLECOURT in *La Revue des Arts*, v (1955), fig. 1, p. 254; LECLANT in *Orientalia*, n.s. 24 (1955), pl. xxvi [17], p. 305; 25 (1956), pl. xli [10], pp. 256–7 [B, b]; LAUER, *Hist. mon.* i, pls. xli–xliii; FAKHRY, *The Pyramids*, figs. 20–1. View of East Gallery, GONEIM, pl. xxx. View of stone vessels *in situ* in Side Passage, id. ib. pl. xxix; *I.L.N.* June 19, 1954, fig. on p. 1044 [lower left]; LECLANT in *Orientalia*, n.s. 24 (1955), pl. xxvii [18], p. 305.

Burial chamber.

View¹ with uninscribed alabaster sarcophagus, GONEIM, pls. li–liv, lvi–lx; id. *The Buried Pyramid*, figs. 40–3; id. in *Bull. Inst. Ég.* xxxvi (1953–4), figs. 12–14 on pp. 576, 579, 580; id. in *La Revue du Caire*, xxxiii, No. 175 (1955), fig. 26; LAUER, *Hist. mon.* i, pls. xlv, xlvi, fig. 56, pp. 194–6; id. *Les Pyramides de Sakkarah* (1972), fig. 67, p. 16; id. *Mystère*, pl. 10 [a, b]; id. *Saqqara*, pl. 116; LECLANT in *Orientalia*, n.s. 24 (1955), pls. xxviii–xxix [19, 20], pp. 303–6; 25 (1956), pls. xlii–xliii [11, 12], pp. 256–7 [B, b]; id. and RACCAH, *Dans les pas des Pharaons*, pl. 6; *I.L.N.* June 19, 1954, figs. on p. 1044 [upper and lower right]; *Egypt Trav. Mag.* (Special Issue 1954), fig. on p. 64 [lower]; SAINTE FARE GARNOT in *Bull. Soc. fr. d'Ég.* No. 17 (Feb. 1955), fig. 1, pp. 8, 10; ZIOCK, *Ägypten (Kurt Schroeders Reiseführer)*, pl. facing page 144 [left]; DESROCHES NOBLECOURT in *La Revue des Arts*, v (1955), fig. 2, p. 254; FAKHRY, *The Pyramids*, figs. 23–4; ALDRED, *Egypt*, fig. 70.

Finds, Dyn. III. From Main Corridor.

Stone vessels. View, GONEIM, pls. xxxiv [B], xxxv, xxxvi [A]; id. in *Bull. Inst. Ég.* xxxvi (1953–4), fig. 9 on p. 574. Vessel with name of Iynikhnum in ink, mentioning *heb-sed*, alabaster, fragments, GONEIM, pl. lxx [A], p. 21 [top].

Six sealings of an official, with name of Sekhemkhet. Id. ib. pl. xxxvii [B], figs. 27–31, pp. 14–15.

Plaque of 'Ankhnebtyseserty  f, with linen-list, ivory, in Cairo Mus. JE 92679. Id. ib. pls. lxx [B], lxxvi, pp. 21–2; id. *The Buried Pyramid*, fig. 47; HELCK in

¹ Selected references.

W.Z.K.M. 54 (1957), pp. 72–6 with fig.; LAUER, *Hist. mon.* i, fig. 57, pp. 201–3. Name, see id. in *B.I.F.A.O.* lxi (1962), pp. 25–8. See id. in *Ann. Serv.* liv (1957), p. 113; LECLANT in *Orientalia*, n.s. 25 (1956), p. 257 [top]; H. BR[UNNER] in *Archiv für Orientforschung*, xvii (1954–6), p. 474.

NORTH ENCLOSURE WALL.

GONEIM, pp. 1–6. Views, id. *ib.* pls. ix, x, cf. vii bis, viii; id. *The Buried Pyramid*, figs. 13, 14; id. in *Bull. Inst. Ég.* xxxvi (1953–4), fig. 3 on p. 562; id. in *La Revue du Caire*, xxxiii, No. 175 (1955), fig. 20; LAUER in *Bull. Soc. fr. d'Ég.* No. 12 (Feb. 1953), fig. 2, pp. 27–8; id. *Hist. mon.* i, pls. xxxvii [2], xxxviii; id. *Les Pyramides de Sakkarah* (1972), fig. 66, p. 15; id. *Mystère*, pl. 10 [c]; id. *Saqqara*, pl. 114; *I.L.N.* June 7, 1952, figs. 5–7, p. 981; *Chron. d'Ég.* xxvii (1952), fig. 25, pp. 351–4; LECLANT in *Orientalia*, n.s. 22 (1953), pl. xiv [27–8], pp. 92–3 [b]; 25 (1956), pl. xlv [13], pp. 256–7 [B, b]; id. and RACCAH, *Dans les pas des Pharaons*, pl. 5; FAKHRY, *The Pyramids*, fig. 18; JAMES, *The Archaeology of Ancient Egypt*, fig. on p. 31.

Masons' marks and graffiti, including name of Imhōtep. GONEIM, pls. xi–xiii, figs. 1–24, pp. 1–4.

SOUTH TOMB.

Description, with views and plans (some showing position only), LAUER in *Bull. Soc. fr. d'Ég.* No. 40 (July 1964), pp. 16–20, with plan; No. 47 (Dec. 1966), pl. ii, fig. 1, pp. 23–6; No. 52 (July 1968), pl. iii [B], fig. 1, pp. 18–23; No. 56 (Nov. 1969), fig. 1, pp. 14–15; id. in *Ann. Serv.* lix (1966), pls. i–x, pp. 53–61; id. in *Comptes rendus* (1966), pl. ii [b], fig. 1, pp. 456–60; (1967), pls. ii, iii, figs. 1, 2, pp. 496–508; (1969), fig. 1, pp. 463–5; (1972), pp. 579–81 with pl. ii, fig. 1; id. in *Rev. d'Ég.* xx (1968), pl. 5, figs. 1, 2, 4, pp. 100–7; id. in *Bull. Inst. Ég.* xlvi–xlix (1966–8), pls. i, ii, fig. 2, pp. 121–31; id. *Saqqara*, pl. 117, fig. 9, pp. 138–40; with view, LECLANT in *Orientalia*, n.s. 37 (1968), pl. xx [19], pp. 105–6 [7]; 43 (1974), pl. xii [15], p. 182 [i]; 44 (1975), pl. xi [1], p. 207 [h].

Remains of wooden coffin and fragments of gold leaf. LAUER in *Comptes rendus* (1967), pl. iv, fig. 3, pp. 502–5; id. in *Rev. d'Ég.* xx (1968), pl. 6, pp. 101–3; id. in *Bull. Inst. Ég.* xlvi–xlix (1966–8), pls. iii [B], iv [A], pp. 126–8; coffin, id. *Saqqara*, pl. 118; LECLANT in *Orientalia*, n.s. 37 (1968), pl. xx [20–1].

E. 'GREAT ENCLOSURE'. Probably Dyn. III

MARAGIOGLIO and RINALDI, *L'Architettura*, ii, p. 53 with position on Tav. 7; SPENCER in *Orientalia*, n.s. 43 (1974), p. 3 [upper]. See vertical aerial views of Step Pyramid enclosure of Sekhemkhet, *supra*.

F. PYRAMID-COMPLEX OF UNIS  Dyn. V

VALLEY TEMPLE.

HASSAN in *Ann. Serv.* xxxviii (1938), pp. 520–1; *Chron. d'Ég.* xiii (1938), p. 283 [iii]; *Archiv aeg. Arch.* 1 (1938), p. 182. Plan, section, and views, HUSSEIN in *Ann. Serv.* xliii (1943), pls. xxix [B], xxx, xxxii, pp. 441–2. Views, RASLAN in *ib.* lxi (1973), figs. 1, 10 [a–f], p. 152 [3]; of granite palm-column, BINDER-HAGELSTANGE, *Ägypten. Ein Reiseführer* (1966), fig. on p. 322; of quay, DRIOTON in *Bull. Inst. Ég.* xxvi (1943–4), fig. 2, p. 81; BRUNTON in *I.L.N.* Feb. 26, 1944, fig. on p. 247 [top].

CAUSEWAY.

Plans and sections, HUSSEIN in *Ann. Serv.* xliii (1943), pls. xxxi, cf. xxviii, xxix [A] (views), pp. 439-41; DRIOTON in *Bull. Inst. Ég.* xxvi (1943-4), fig. 1, pp. 80-1; with views and reconstruction, RASLAN, op. cit. figs. 2, 3 [a], 4 [a], 5-9, 11, 14 [a, b], pp. 153-68. Reconstruction, LAUER in *Bull. Soc. fr. d'Ég.* No. 33 (March 1962), figs. 1, 2, pp. 13-14. View, HASSAN in *Ann. Serv.* xxxviii (1938), pl. xciv, p. 519; id. in *Ā.Z.* 80 (1955), Taf. xii [1], pp. 136-7; LEIBOVITCH, *Anc. Eg.* fig. 157, p. 270; LAUER, *Problème*, pl. xiii [3]; id. *Mystère*, pl. 13 [b]; id. *Les Pyramides de Sakkarah* (1972), fig. 69, pp. 19-20; id. *Saqqara*, pl. xvi; SÉE, *Naissance*, fig. on pp. 206-7; DE RACHEWILTZ in *Archivio Internazionale di Etnografia e Preistoria*, ii (1959), Tav. vi [14, 15], p. 42.

Block with sketch to be re-used for making statue, id. ib. Tav. v [8], p. 41.

Blocks with reliefs.

Description of some, HASSAN in *Ann. Serv.* xxxviii (1938), pp. 519-20 [A-F]; id. in *Ā.Z.* 80 (1955), pp. 137-9; *Chron. d'Ég.* xiii (1938), p. 282 [a-f]; *Archiv aeg. Arch.* 1 (1938), pp. 180-2 [a-f]; SMITH, *Hist. Eg. Sculp.* pp. 181-2. List and texts, ČERNÝ Notebook, 120, pp. 56-78 [Nos. 1-120], and copies of some by Grdseloff, pp. 103-4. See also DE RACHEWILTZ, op. cit. pp. 38-42, cf. Tav. iii [1], iv [6, 7].

Transport of columns, architraves, etc.

Registers, I (bottom only), boat, II, transport of two granite palm-columns by boat, and stern of another boat, III (top only), text. [ČERNÝ, No. 25.] HASSAN in *Ā.Z.* 80 (1955), fig. 1, pp. 137-8; *Archiv aeg. Arch.* 1 (1938), Taf. xiv [a], p. 180 [a]; GOYON (G.) in *B.I.F.A.O.* 69 (1970), pl. iii, pp. 11-36. II, LAUER, *Problème*, pl. xiii [2]; text, HASSAN in *Ann. Serv.* xxxviii (1938), p. 519 (modified).

Two adjoining blocks, boat carrying two columns, and another boat with cornices. [ČERNÝ, No. 24.] GOYON (G.), op. cit. pls. iv, v, pp. 11-36 (with text); block on left, LAUER, *Saqqara*, pl. 125; DE RACHEWILTZ, op. cit. Tav. iii [2], pp. 38-9.

Boats. [ČERNÝ, Nos. 14, 26-7.]

Text. [ČERNÝ, No. 30.] Part, FISCHER in *Ĵ.E.A.* 61 (1975), p. 33.

Battle-scenes and transport of prisoners. [Also ČERNÝ, Nos. 116-18.]

Three blocks, including one showing man wielding battle-axe. DE RACHEWILTZ, op. cit. Tav. v [10], vi [12, 13], p. 42.

Registers, I, fight between Egyptians and Bedouins, II, remains of text. [ČERNÝ, No. 32.] HASSAN in *Ann. Serv.* xxxviii (1938), pl. xcv, p. 520 [B]; SCHWEITZER in *Orientalia*, n.s. 17 (1948), pl. xxiii [8], p. 267; DE RACHEWILTZ, *L'Arte*, Tav. 15 [lower], pp. 19-20; id. in *Archivio* [etc.], ii (1959), Tav. iv [4], p. 39.









Legs of men. Id. ib. Tav. v [11], p. 42; id. *L'Arte*, Tav. 15 [upper], pp. 19-20.

Transport of Asiatics by sea-going ships. [ČERNÝ, No. 22.] HASSAN in *Ā.Z.* 80 (1955), fig. 2, p. 138; *Archiv aeg. Arch.* 1 (1938), Taf. xiv [b], p. 180 [b].

King, divinities, courtiers, estates, etc.

Twenty-seven blocks with estates. [ČERNÝ, Nos. 63, 87, 90-5, 97, 99, 100, 103-10 (without Nos. 16-20, 23-7 of JACQUET-GORDON).] Names, JACQUET-GORDON, *Domaines*, pp. 168-82 [7R5], cf. fig. 8.

King on throne, with wife, carried in palanquin, divinities (including Anubis, Duamutf, Horus Behdetite, Inmutf, Mest $\left\{ \begin{array}{l} \overline{\Delta} \\ \Delta \end{array} \right.$, Nile-gods, Sepa, Sokari, Sopt, Thoth), crews of

Unis, officials (including Hemkhnum , Idu, Irenptah , Isesikhaef , Iykau , Kanufer, Kar , Khuenkhnum , Neferseshemptah, Neferseshemshet , Nitankh-khnum, Nitankhmin, Nikauisesi , Embalmer of Anubis, Ptahhotp, Ptahshepses, Isesizedef , and offering-bringers. [ČERNÝ, Nos. 1, 2, 4-10, 12, 13, 15-18, 20, 23, 28, 31, 33-43, 45-6, 52-4, 57, 62, 67-9, 77, 80, 82, 88, 96, 98, 101-2, 111-15.]

Registers, **I**, legs of divinities, **II**, 'followers' with staffs, **III**, remains of text. [ČERNÝ, No. 65.] DE RACHEWILTZ in *Archivio* [etc.], Tav. v [9], p. 41.

Remains of text. [ČERNÝ, Nos. 81, 83, 85-6, 89, 120.]

Seasons.

Reconstruction of part, SMITH, *Interconnections in the Ancient Near East*, fig. 179, p. 145.

Two adjoining blocks. [ČERNÝ, No. 60.] (a) Registers, **I**, mullet, **II**, two sub-registers of animals, **III**, lion attacking bull, birds hovering. **II-III**, SCHWEITZER in *Orientalia*, n.s. 17 (1948), pl. xxii [7], p. 267. (b) Registers, **I**, mullet, **II**, hunting with lasso in desert, with two sub-registers of animals, **III**, birds hovering, dragon-fly and butterfly, two sub-registers, left, reaping corn in both, right, picking figs, and rams mounting sheep. HASSAN in *Ä.Z.* 80 (1955), Taf. xii [2], p. 138; text of birds on eggs, EDEL, *Zu den Inschriften auf den Jahreszeitenreliefs der Weltkammer* [etc.] in *Nachr. Göttingen* (1961), No. 8, p. 233.

Registers, **I**, vintage, **II**, mullet, **III**, remains of animals and trees. [ČERNÝ, No. 61.] **II**, KEIMER in *Bull. Inst. Ég.* xxi (1938-9), pl. iv [2], p. 219.

Several adjoining blocks, netting fowl, with birds hovering, mice breeding, man driving cattle, and sealing jars with honey. [ČERNÝ, No. 58.] Text, EDEL, op. cit. p. 225 [7].

Adjoining blocks (one re-used in sarcophagus of Late Period), registers, **I**, gazelles, oryxes mating, and hunting with lasso, **II**, giraffe, hare, etc. [ČERNÝ, No. 70.] SCHWEITZER in *Orientalia*, n.s. 17 (1948), pl. xxi [6], p. 267; left part, HASSAN in *Ä.Z.* 80 (1955), Taf. xiii [1], p. 138.

Registers, **I**, feet of man with dogs and desert animals, **II**, antelopes giving birth, dog attacking gazelle, oryxes and ibexes, **III**, remains of animals. HASSAN in *Ann. Serv.* xxxviii (1938), pl. xcvi [A], p. 520 [F]; *I.L.N.* June 4, 1938, fig. 1, p. 1000; *Archiv aeg. Arch.* 1 (1938), fig. 2, p. 182 [f]; KEIMER in *Bull. Inst. Ég.* xxv (1942-3), figs. 1, 2, pp. 101-21; CAPART, *L'Art ég.* iii, pl. 436 [lower]; right part, PIRENNE, *Hist. civ.* i, back inside cover; **II**, LAUER, *Saqqara*, pl. 127.

Registers, **I**, lion, lioness, and gazelles, **II**, remains of antelope, etc. CAPART, op. cit. pl. 436 [upper]; LAUER, *Problème*, pl. xiii [1].

Libyan zorils. KEIMER, *Études d'Égyptologie*, iv (1942), figs. 12, 13, pp. 19-20.

Two registers of animals and men. [ČERNÝ, No. 76.] Hieroglyph of *neh*-bird, id. in *Ann. Serv.* xli (1942), figs. 64-5, pp. 328-9.

Wild dog. KEIMER in *B.I.F.A.O.* lv (1955), fig. 5, pp. 12-13 [C].

Various scenes with animals (including hunting with throw-stick and lasso). [ČERNÝ, Nos. 3, 44, 47-51, 55-6, 59, 64, 66, 71-5, 78-9, 84, 119 (possibly).]

Trades and market.

Bottom register *in situ*, goldsmiths, silversmiths and metal-workers, men with baskets of fish and vegetables, man and boy with baboons. [ČERNÝ, No. 21.] HASSAN in *Ann. Serv.*

xxxviii (1938), pl. xcvi, p. 520 [E]; LAUER, *Saqqara*, pls. 128–30; man with vegetables, and men with baboons, HASSAN in *Ä.Z.* 80 (1955), pl. xiii [2], p. 139.

Sandal-maker. [ČERNÝ, No. 19.]

Famine-scenes.

Registers, I–II, famine-stricken peasants, III, remains of titles. [ČERNÝ, No. 11.] DRIOTON in *Bull. Inst. Ég.* xxv (1942–3), figs. 3, cf. 4–8, pp. 48–52; id. in *Rev. Arch.* 6 Sér. xxvii (1947), fig. 1, pp. 101–2; BRUNTON in *I.L.N.* Feb. 26, 1944, fig. on p. 249 [upper]; SCHWEITZER in *Orientalia*, n.s. 17 (1948), pl. xxiv [9] (from DRIOTON), p. 267; PRITCHARD, *Anc. Near East*, fig. 102; DE RACHEWILTZ, *L'Arte*, Tav. 14, p. 19; MAZAR, *Views*, i, pl. 108; ALDRED, *The Egyptians*, pl. 17; SCHOTT in *Rev. d'Ég.* 17 (1965), pls. 1–4 [A], pp. 7–12; LAUER, *Saqqara*, pl. 126; RASLAN in *Ann. Serv.* lxi (1973), fig. 3 [b], p. 154 [a]; II, four men on left, SÄVE-SÖDERBERGH, *Egyptisk Egenart*, fig. 41, p. 111; man on left, DE RACHEWILTZ in *Archivio* [etc.], ii (1959), Tav. iv [5], p. 39.

Two registers, famine-stricken peasant in each, in Louvre, E.17381. VANDIER in *Bulletin des Musées de France* (March 1950), fig. 4, pp. 27–8 (as E.17376); FISCHER in *Artibus Asiae*, xxii (1959), fig. 13, p. 251; *Vingt ans*, p. 20 [Cat. 72] with pl.; DESROCHES-NOBLECOURT, *L'Art ég.* fig. 23; SCHOTT in *Rev. d'Ég.* 17 (1965), pl. 4 [B] (as E.17376), pp. 12–13; LECA, *Médecine*, fig. 101 (as E.17376); BRUNNER-TRAUT, *Die Alten Ägypter*, Taf. 54. See VANDIER, *Guide* (1973), p. 12.

BOAT-PITS. Two, south of Causeway.

Plans, with section of north boat-pit, GOYON (G.) in *B.I.F.A.O.* 69 (1970), pl. ii, pp. 36–7. View of both, SCHWEITZER, *Forschungsergebnisse in Ägypten in den Nachkriegsjahren*, Abb. 5, p. 9; id. in *Orientalia*, n.s. 19 (1950), pl. i [2], p. 120; LAUER, *Saqqara*, pl. xvii. Plan, sections, and views of north boat-pit, HASSAN, *Giza*, vi [1], fig. 35, pls. ii, iii, p. 82; view, LAUER, *Problème*, pl. xiv; id. *Les Pyramides de Sakkarah* (1972), fig. 70, p. 20; id. *Mystère*, pl. xii [a]; SAMIVEL and AUDRAIN, *The Glory of Egypt*, pl. 14; VANDERSLEYEN, *Das Alte Ägypten*, Abb. 37; see HASSAN in *Ann. Serv.* xxxviii (1938), p. 520.

MORTUARY TEMPLE.¹

LABROUSSE, LAUER and LECLANT, *Le Temple haut du complexe funéraire du roi Ounas* (in press); FIRTH in *Ann. Serv.* xxx (1930), pp. 186–7 with plan (by LAUER). Plan, LAUER, *Problème*, fig. 31; id. *Mystère*, fig. 43; id. *Les Pyramides de Sakkarah* (1972), fig. 74, p. 17; FAKHRY, *The Pyramids*, fig. 103 (from LAUER), p. 183. View, MORET, *Au temps des Pharaons*, pl. ix [2]; id. *In the Time of the Pharaohs*, pl. ix [2]; COTTRELL, *Egypt*, fig. 35; of north-east magazines, LAUER in *Ann. Serv.* xxxvii (1937), pp. 112–13 with plate.

Palm-columns with names of the King (those in museums are of red granite). Texts of two, BARSANTI in *Ann. Serv.* ii (1901), p. 254. (a) and (b) In Cairo Mus. JE 35131; MASPERO, *Égypte*, fig. 89; id. and ROEDER, *Führer*, Taf. 1, 12 [right], p. 25 [71–2]; MASPERO, *Guide*, fig. 15, p. 59 [132–3]; one, JÉQUIER, *L'Architecture*, i, pl. 6 [1]; PETRIE, *Arts and Crafts*, fig. 84; MURRAY, *Egyptian Temples*, pl. iii [2]; VON BISSING, *Äg. Kunstgeschichte*, Taf. xxxiii [258], *Text*, i, p. 74; capital, DESROCHES-NOBLECOURT, *L'Art ég.* fig. 6; of the other one, VON BISSING, op. cit. Taf. xxxiii [262]; BORCHARDT, *Works of Art*, pl. 47 [right]; SPIEGELBERG, *Geschichte*, Abb. 41. (c) Louvre, E.10959; GOYON (G.) in *B.I.F.A.O.* 69 (1970), pl. i, p. 12; BOREUX in *Bulletin des Musées de France*, 1 (1929), fig. on p. 4, cf. p. 2; see id. *Guide*, i, pp. 232–3; VANDIER, *Guide* (1948 and 1952), p. 9; (1973), p. 14. (d) Brit. Mus. 1385; see *Guide (Sculpture)*, p. 18 [50]; *Guide, Eg. Collns.* (1930), p. 298; (1964), pp. 33–4. (e) New

¹ See Addenda.

York, M.M.A. 07.229.2; *M.M.A. Bull.* n.s. xxxiii (Summer 1975), fig. on p. 111 [right]; see ib. ii (1907), p. 206.

Architrave with name of the King. Text, BARSANTI in *Ann. Serv.* ii (1901), p. 255.

Relief-fragments. LABROUSSE, LAUER and LECLANT, op. cit. pls. xxviii-xxxvii, figs. 44-144, pp. 77-123 [19-119]; some, ARCH. LACAU phot. F. iii. (a) King suckled by goddess, in Cairo Mus. JE 39133; SMITH, *Hist. Eg. Sculp.* pl. 54 [b], pp. 177, 281; MÜLLER, *Äg. Kunst*, Abb. 33; see MASPERO, *Guide*, p. 57 [F]. (b) Souls of Nekhen, in Cairo Mus. CG 57119; see SMITH, op. cit. p. 183; BARSANTI, op. cit. p. 255. (c) King, in Cairo Mus. JE 45249. (d) Royal names, in Cairo Mus. JE 40029.

Fragments of statues of kneeling bound captives. See JÉQUIER, *Le Monument funéraire de Pepi II*, iii, p. 28 note 2.

Cylindrical vase of Unis, alabaster, possibly from here, formerly in Abbott and N.Y. Hist. Soc. Collns., now in Brooklyn Mus. 37.76E. PRISSE, *Mon.* xlix [6]; id. in *Rev. Arch.* ii (1845-6), fig. on p. 734 [top]; *N.Y.H.S. Cat.* p. 44 [700] with fig.; RIEFSTAHL, *Toilet Articles from Ancient Egypt*, pl. 3 [lower right]; WILKINSON MSS. xx.A.11 [middle left]; NESTOR L'HÔTE MSS. 20396, 205; text, L. *D. Text*, i, p. 7 [4]; GAUTHIER, *Livre des Rois*, i, p. 140 [vii]; JAMES, *Corpus*, i, pl. xxiii [53], pp. 20-1.

PYRAMID. Lepsius, XXXV; Perring and Vyse, 4.

BARSANTI in *Ann. Serv.* ii (1901), pp. 244-57, plan, p. 246 (with Mortuary Temple).

Exterior. See VYSE, *Operations*, iii, p. 51

Section, PERRING, *Pyramids*, iii, pl. viii [2]. Views, PIANKOFF, *The Pyramid of Unas*, pls. i, ii; BREASTED, *History*, fig. 73.

Masons' marks, PETRIE in SAYCE MSS. 14c [near bottom].

South face.

Restoration-text of Kha'emwëset (son of Ramesses II). LAUER in *Ann. Serv.* liv (1957), fig. 3, pp. 114-16; GOMAA, *Chaemwese* [etc.], Abb. 2, 5-6, p. 77 [7]; incomplete, DRIOTON and LAUER in ib. xxxvii (1937), pls. i, ii, pp. 201-11 [Text A]; GRINSELL, *Barrow, Pyramid and Tomb*, fig. 58.

Re-used blocks from Mortuary Temple of Isesi, and palace-façade stela on south-west corner. See LAUER in *Ann. Serv.* xxxix (1939), pp. 453-4; *Chron. d'Ég.* xv (1940), pp. 68, 70.

Interior



Plan and section, MASPERO in *Rec. Trav.* iii (1882), pl. facing p. 177 [lower]; id. *Inscr.* pl. facing p. 2 [lower]; PIANKOFF, *The Pyramid of Unas*, plan B. Plan, FAKHRY, *The Pyramids*, fig. 104. View of entrance, MASPERO, *Hist. anc.* i, fig. on p. 439; PIANKOFF, op. cit. pl. iii.

Pyramid-texts.

PIANKOFF, *The Pyramid of Unas* (in photographs); SETHE, *Pyramidentexte*, i, lines W; iii, pp. 116-20 (with plan and disposition on walls); iv, on pl. at end; MASPERO in *Rec. Trav.* iii (1882), pp. 179-224; iv (1883), pp. 41-78 (repr. *Inscr.* pp. 3-86); cf. LANGE (H. O.) in *Ä.Z.* xxxiv (1896), pp. 139-43. Names of Ennead, BRUGSCH, *Thes.* 725 [9]. Offering-list, DÜMICHEN, *Grabpalast*, i, Taf. xviii-xxvi [g].

Views of texts in Burial Chamber, SOGA, *The Nile*, fig. on p. 73 [right] (reversed); EDWARDS, *Pyramids* (1961), pl. 23; BINDER-HAGELSTANGE, *Ägypten. Ein Reiseführer* (1966), fig. on p. 345; ALDRED, *Egypt*, figs. 94-5; CAPART, *Rue de Tombeaux*, pl. v; MERTZ, *Temples*,

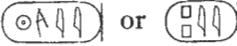
Tombs and Hieroglyphs, pl. facing p. 96; SPIEGEL in *Ann. Serv.* liii (1956), pls. i, ii, pp. 339–439; LAUER, *Saqqara*, pl. xv; showing sarcophagus, id. ib. pl. i; MASPERO, *Hist. anc.* i, fig. on p. 437; SCHÄFER and ANDRAE, *Kunst* (1925), 206; (1930 and 1942), 214; GRINSELL, *Eg. Pyramids*, pl. xi facing p. 137; DE CENIVAL, *Living Architecture: Egyptian*, pl. 44. Views of texts in Antechamber, SPIEGEL, op. cit. pls. iii, iv; CAPART, *Rue de Tombeaux*, pl. iv; id. *L'Art ég.* (1909), pl. 6; id. *L'Art ég.* i, pl. 42; id. *Memphis*, figs. 206–7; LAGIER, *L'Égypte monumentale et pittoresque*, pl. 13; DAUMAS, *Civ. de l'Ég.* pl. 146; SOGA, op. cit. fig. on p. 73 [left]; MASPERO, *Égypte*, fig. 77; DUNCAN in ROBINSON, *From the Pyramids to Paul*, pl. facing p. 28; LAUER, *Problème*, pl. xvi; id. *Mystère*, pl. 15 [a]; id. *Les Pyramides de Sakkarah* (1972), fig. 68, p. 18; id. *Saqqara*, pl. 60; SANDER-HANSEN, *De Gammelægyptiske Pyramide-tekster* [etc.], fig. 10; WESTENDORF, *Das Alte Ägypten*, fig. on p. 56 [lower]; MICHAŁOWSKI, *Piramidy i mastaby*, pl. 74; GARDINER MSS. photo. 28.1058.

G. PYRAMID-COMPLEX OF PEPY I.  or .
Dyn. VI

MORTUARY TEMPLE.

Plan, LAUER in *Comptes rendus* (1970), fig. 3, pp. 491–503. Views, LECLANT in *Orientalia*, n.s. 43 (1974), pls. xiii–xvi [16–20], xvii [23–4], pp. 182–3 [j]; 44 (1975), pls. xii [3], xiv [5], p. 207 [i]; of magazines, 39 (1970), pl. xxxii [26–7], p. 333; 40 (1971), pl. xxxii [25], p. 233; LAUER in *Bull. Soc. fr. d'Ég.* No. 56 (Nov. 1969), fig. 2, p. 17; id. in *Comptes rendus* (1969), pl. iii, p. 468; (1970), pls. iv [b], vi, viii [a]; id. in *Bull. Inst. Ég.* li (1969–70), pl. i, p. 38; id. *Saqqara*, pl. 158; id. and LECLANT in *Rev. d'Ég.* 21 (1969), fig. 1 on p. 56.

Heads and fragments of statues of kneeling bound captives. Id. ib. pls. 8–10, figs. 2–6, pp. 55–62. Some, LECLANT in *Orientalia*, n.s. 39 (1970), pls. xxvii–xxxii [20–5], xxxiii [28–30], p. 333; 40 (1971), pl. xxxiii [26], p. 233; 43 (1974), pl. xvi [21–2], p. 184 [top]; LAUER in *Bull. Soc. fr. d'Ég.* No. 56 (Nov. 1969), pls. ii, iii, fig. 3, pp. 18–24; No. 62 (Oct. 1971), fig. on p. 45 [left]; id. in *Comptes rendus* (1969), pls. iii–vi, fig. 2, pp. 468–78; (1970), pls. viii [b], ix [a, b], p. 498; (1973), pl. v [a, b], p. 328; id. in *Bull. Inst. Ég.* li (1969–70), pls. ii, iii, pp. 38–43; id. *Mystère*, pls. xiv [a, b], 16; BIETAK in *Archiv für Orientforschung*, xxiii (1970), Abb. 35, p. 208.

Male head, fragmentary, sandstone. LAUER in *Comptes rendus* (1972), fig. 3 on p. 585; id. in *Bull. Soc. fr. d'Ég.* No. 62 (Oct. 1971), fig. on p. 45 [right], cf. p. 46.

Blocks mentioning King's mother, re-used. (a) Id. ib. No. 52 (July 1968), fig. 3, p. 27. (b) With names of Teti, inscribed on two faces, id. in *Comptes rendus* (1970), pl. ix [c], pp. 498, 501; LECLANT in *Orientalia*, n.s. 40 (1971), pl. xxxi [23], p. 233; 43 (1974), pl. xviii [25], p. 183.

Blocks. Upper part of Horus Behdetite; id. ib. pl. xviii [27], pp. 183–4; LAUER in *Comptes rendus* (1973), pl. v [c], p. 329. Offering-bringers, LECLANT in *Orientalia*, n.s. 43 (1974), pl. xviii [26], p. 183.

Block-statue of Smenkhuptah , Inspector of prophets of the Pyramid of Pepy I, etc., Middle Kingdom. LECLANT in *Orientalia Lovaniensia Periodica*, 6/7 (1975–6), pls. xii, xiii, figs. 2, 3, cf. 1, pp. 355–9; id. in *Orientalia*, n.s. 44 (1975), pl. xiii [4], p. 207.

Two other Middle Kingdom statues, inscribed, id. ib. pls. xv–xvii [6–9], p. 207.

Alabaster vessels of Pepy I. Possibly from here.

Cylindrical vases. (a) With inscribed lid, in Brit. Mus. 22559; *Guide, Eg. Collns.* (1930), on fig. 160, p. 301; *Guide, 4th to 6th*, on pl. ii, p. 15 [9]; *Guide, 3rd and 4th*, on pl. vii, p. 248 [62]; BUDGE, *A History of Egypt*, ii, figs. on pp. 96, 104; id. *The Mummy* (1925),

on pl. xxvii [lower]; ROSS, *The Art of Egypt*, pl. on p. 118 [2, right]. (b) Brit. Mus. 38074; see *Guide, Eg. Collns.* (1930), p. 301; *Guide, 4th to 6th*, p. 15 [8]; *Guide, 3rd and 4th*, p. 249 [63]. (c) With inscribed lid, formerly in Abbott and N.Y. Hist. Soc. Collns., now in Brooklyn Mus. 37.70E; PRISSE, *Mon.* xlix [7]; id. in *Rev. Arch.* ii (1845-6), fig. on p. 734 [lower right]; *N.Y.H.S. Cat.* p. 44 [702] (as Thebes) with fig. (marked 705); RIEFSTAHL, *Toilet Articles from Ancient Egypt*, pl. 3 [lower, middle right]; *Eg. Art . . . Brooklyn*, fig. 23 [right]; WILKINSON MSS. xx. A. 11 [middle right]; text, *L. D. Text*, i, p. 7 [2]; JAMES, *Corpus*, i, pl. xxiv [61], pp. 24-5; see BONOMI, *Cat. Colln. Abbott*, pp. 18-19 [135]. (d) Formerly in Abbott and N.Y. Hist. Soc. Collns., now in Brooklyn Mus. 37.61E; RIEFSTAHL, op. cit. pl. 3 [lower left]; text, *L. D. Text*, i, p. 7 [3]; JAMES, op. cit. pl. xxiii [60], p. 24; see *N.Y.H.S. Cat.* p. 44 [703]. (e) Formerly in Meux Colln. 1391 and Hearst Colln.; *Sotheby Sale Cat.* (HEARST), July 11-12, 1939, on pl. vi, No. 86; text, BUDGE, *Some Account of the Collection of Egyptian Antiquities in the Possession of Lady Meux* (1896), p. 360 [1391].

Jar, text mentioning 1st *heb-sed*, alabaster, in Berlin (East) Mus. 7715. SCHÄFER and ANDRAE, *Kunst* (1925), 258 [left]; (1930 and 1942), 272 [left]; Muzeul de artă, Bucharest. *Egiptul antic* [etc.] (1975), No. 102 with fig. on p. 56 [left lower]. Text, *Aeg. Inscr.* i, p. 5; SETHE, *Urk.* i. 97 [15, C]. See *Ausf. Verz.* p. 44; *Führer* (1961), p. 49.

PYRAMID. Lepsius, XXXVI; Perring and Vyse, 5.

L. D. Text, i, pp. 196-8, with plan and section. Section, PERRING, *Pyramids*, iii, pl. viii [3]; see VYSE, *Operations*, iii, p. 51. Plan and section of interior, MASPERO in *Rec. Trav.* v (1884), pl. facing p. 158 (repr. *Inscr.* pl. facing p. 148). Views of interior, PETRIE, *History*, i (1923), fig. 66; LAUER in *Bull. Soc. fr. d'Ég.* No. 46 (July 1966), pl. iv, p. 16; No. 52 (July 1968), pl. iv [B], pp. 23-7; id. in *Comptes rendus* (1969), pl. ii, p. 466; (1972), pl. iii, p. 583; id. *Mystère*, pl. xiii; id. *Saqqara*, pl. 154; LECLANT in *Orientalia*, n.s. 36 (1967), pls. xxx-xxxii [15-18], p. 189 [β]; 37 (1968), pl. xxi [22-3], pp. 106-7 [δ]; 38 (1969), pl. xxiv [28], p. 256; 40 (1971), pl. xxvii [16], p. 232; 41 (1972), pls. x-xi [5-7], pp. 256-7 [g].

Pyramid-texts.

SETHE, *Pyramidentexte*, i, ii, lines P; iii, pp. 125-35 (with plan and disposition on walls); iv, on pl. at end; MASPERO in *Rec. Trav.* v (1884), pp. 159-98; vii (1886), pp. 145-76; viii (1886), pp. 87-120 (repr. *Inscr.* pp. 149-254); cf. LANGE (H. O.) in *Ä.Z.* xxxiv (1896), pp. 144-6. Parts, BRUGSCH in *ib.* xix (1881), p. 12; BIRCH in *P.S.B.A.* iii (1881), pls. between pp. 116-17 (copied by Petrie); VON BISSING and BORCHARDT in *Ä.Z.* xxxvii (1899), pp. 105-22, cf. 103-4.

Views showing Pyramid-texts, LECLANT in *Orientalia*, n.s. 38 (1969), pl. xxiv [29], p. 256; 39 (1970), pl. xxxv [33], p. 332 [bottom]; 40 (1971), pl. xxvii [17], p. 232; 43 (1974), pl. xix [28], p. 184; 44 (1975), pl. xviii [10, 11], p. 207 [i]; id. in *Bull. Soc. fr. d'Ég.* No. 58 (June 1970), fig. on p. 11; id. in *Rev. d'Ég.* 27 (1975), figs. 1, 2, pp. 135-49; LAUER in *Bull. Soc. fr. d'Ég.* No. 52 (July 1968), pl. iv [A], p. 24; No. 56 (Nov. 1969), pl. i [B], pp. 16-17; No. 62 (Oct. 1971), figs. on pp. 42-3, cf. pp. 38, 40; id. in *Comptes rendus* (1970), pl. iv [a], p. 491; id. *Saqqara*, pls. 156-7.

Fragments. Brussels, Mus. Roy. E.2383 (8 fragments); SPELEERS, *Rec. inscr.* p. 7 [52]; see SETHE, op. cit. iii, pp. 133-4. Cairo Mus. CG 1704-5 (5 fragments); texts, id. *ib.* pp. 136 [B, C], 137 [E, F, G]; BORCHARDT, *Denkmäler*, ii, p. 145. Cambridge, Fitzwilliam Mus. E.SS.2, 6, 7, 11. Chicago, Or. Inst. 14049; see ALLEN, *Occurrences of Pyramid Texts* [etc.], p. 50 [etc.]. Leningrad, State Hermitage Mus. 18143 (formerly Likhachev Colln.); TURAEV, *Egiptologicheskaya zametki in Izvestiya Imperatorskoi Akademii Nauk* (1915), pp. 606-7

[ii]. London, Univ. Coll. 2371-2, 14540; No. 14540, SETHE, op. cit. pp. 136-7 [D]. Moscow Mus. I.1.b.317 (formerly Golenishchev Colln. 4061); id. ib. pp. 135-6 [A]. Uppsala, Victoriamus. 21; id. ib. p. 138 [M], cf. 126; LUGN, *Ausgewählte Denkmäler aus ägyptischen Sammlungen in Schweden*, Taf. x [13], pp. 12-13. Three fragments, formerly in Gardiner Colln.; texts, GARDINER MSS. 29.60C; see SETHE, op. cit. iii, pp. 132-4.

Fragments found by Lauer and Leclant, LECLANT in *Orientalia*, n.s. 37 (1968), pls. xxii-xxiv [24-7], pp. 106-7 [δ]; 38 (1969), pls. xxii-xxiii [25-7], xxv [30-1], p. 256 [δ]; 39 (1970), pls. xxxiv [31-2], xxxvi-xxxvii [34-6], p. 332 [d]; 40 (1971), pls. xxviii-xxx [18-22], xxxi [24], p. 232 [h]; 41 (1972), pls. xii-xiv [8-12], pp. 256-7 [g]; id. in *Bull. Soc. fr. d'Ég.* No. 58 (June 1970), figs. on pp. 12-16; BIETAK in *Archiv für Orientforschung*, xxiii (1970), Abb. 34, 36, pp. 206-8; LAUER, *Saqqara*, pl. 155.



Finds

Linen with name of the King, in Cairo Mus. Text, BRUGSCH, *Thes.* 1212 [bottom right]; SETHE, *Urk.* i. 97 [16]. See MASPERO, *Guide to the Cairo Museum* (1903), p. 472 [57]; GAUTHIER, *Livre des Rois*, i, p. 155 [xxi] (as Abydos).

H. PYRAMID-COMPLEX OF ISESI.  or . Dyn. V

MARAGIOGLIO and RINALDI, *Notizie*, pp. 21-37, with plans and sections, Tav. 4-6.

MORTUARY TEMPLE. See LECLANT in *Orientalia*, n.s. 23 (1954), p. 68.

Graffiti, Dyn. VI. Sefekhptah  Neby  Overseer of commissions of tenants of the Pyramid of Isesi, etc.; FISCHER in *Orientalia*, n.s. 30 (1961), pl. xxv [i], fig. 1, pp. 170-3. [Me]ru  Overseer of commissions of the Pyramid of Isesi; see id. ib. p. 173 [top].

Statues, kneeling bound (a) Asiatic, (b) Libyan, probably from here, in New York, M.M.A. 47.2 and 64.260. *Guide to the Collections. Egyptian Art* (1962), fig. 12. (a) LANSING in *M.M.A. Bull.* n.s. v (Feb. 1947), pp. 149-52 with figs.; *M.M.A. Bull.* n.s. viii (June 1950), on fig. on p. 313; HAYES, *Scepter*, i, fig. 67, p. 115; HORNEMANN, *Types*, iii, pl. 579; POULSEN, *Åg. Kunst. A. und M.* pl. on p. 68; MICHALOWSKI, *Art*, fig. 255; SÉE, *Naissance*, fig. on p. 183. (b) FISCHER in *M.M.A. Bull.* n.s. xxiv (Oct. 1965), fig. on p. 53.

Relief-fragments. King with divinities, including Hathor Mistress of the Sycamore, Sêth and Buto, GOYON (G.) in *B.I.F.A.O.* lxxvii (1969), pl. xxxix, p. 156 [13] with note 2. Processions of estates; names, JACQUET-GORDON, *Domaines*, pp. 160-7 [6R5].

PYRAMID. Lepsius, XXXVII; Perring and Vyse, 6; Haram el-Shawwâf.

VYSE, *Operations*, iii, pp. 51-2. View, FAKHRY, *The Pyramids*, fig. 102, pp. 180-1.

Fragment of canopic-jar of the King, see BATRAWI in *Ann. Serv.* xlvi (1947), p. 100.

PYRAMID-ENCLOSURE PROBABLY OF WIFE OF ISESI. Dyn. V

MORTUARY TEMPLE.

FAKHRY, *Sneferu*, i, p. 31; LECLANT in *Orientalia*, n.s. 23 (1954), p. 69; MARAGIOGLIO and RINALDI, *Notizie*, pp. 38-43, with plan, Tav. 5 [3].

PYRAMID. Lepsius, XXVIII; Perring and Vyse, 7.

VYSE, *Operations*, iii, p. 52; L. D. *Text*, i, p. 198.

I. PYRAMID-COMPLEX OF MERENRĒ I. 

Dyn. VI

MORTUARY TEMPLE.

Views, LAUER, *Mystère*, pl. xv; id. in *Comptes rendus* (1972), pls. vii [b], viii, p. 591.

Vase of the King, possibly from here, in Brit. Mus. 4493. *Guide*, 3rd and 4th, on pl. vii, p. 249 [64]; *Guide*, 4th to 6th, on pl. ii, p. 15 [10]; *Guide*, *Eg. Collns.* (1930), fig. 160 (called 4492 on pls. of *Guides*), p. 302; ROSS, *The Art of Egypt*, pl. on p. 118 [3]; BUDGE, *A History of Egypt*, ii, fig. on p. 111.

PYRAMID. Lepsius, XXXIX; Perring and Vyse, 8.

L. D. Text, i, p. 198. Section, PERRING, *Pyramids*, iii, pl. viii [6]; see VYSE, *Operations*, iii, p. 52. View of blocked entrance passage, LAUER, *Mystère*, pl. xiv [c]; id. in *Comptes rendus* (1972), pl. iv [b], p. 586. Plan and section of interior, MASPERO in *Rec. Trav.* ix (1887), fig. on p. 179 (repr. *Inscr.* fig. on p. 257).

Pyramid-texts.

SETHE, *Pyramidentexte*, i, ii, lines M; iii, pp. 139-45, with plan and disposition on walls; iv, on pl. at end; MASPERO in *Rec. Trav.* ix (1887), pp. 179-91; x (1888), pp. 1-29; xi (1889), pp. 1-31 (repr. *Inscr.* pp. 257-327); BRUGSCH in *Ä.Z.* xix (1881), Taf. ii-ivb, pp. 3-10; cf. LANGE (H. O.) in ib. xxxiv (1896), pp. 146-9; see P.S.B.A. iii (1881), pp. 111-12. Views, LAUER in *Comptes rendus* (1972), pls. v [b], vi, vii [a], pp. 587-8; (1973), pl. vii [b] (caption interchanged with a), p. 331; id. *Mystère*, pl. xvi; LECLANT in *Orientalia*, n.s. 42 (1973), pls. xi-xii [12-14], pp. 402-3 [i]; 43 (1974), pl. xx [29-30], p. 184.

Fragments found by Lauer and Leclant, LAUER in *Comptes rendus* (1972), figs. 5, 6, p. 589; (1973), fig. 1, p. 332; LECLANT in *Orientalia*, n.s. 42 (1973), pls. xiii-xv [15-22], pp. 402-3 [i].

J. PYRAMID OF KAKARĒ IBI  Dyn. VIII

Lepsius, XL.

L. D. Text, i, pp. 198-9; JÉQUIER, *La Pyramide d'Aba*; id. in *Ann. Serv.* xxx (1930), pp. 112-14; id. *Douze ans*, pp. 96-100. Plans and views, id. *La Pyramide d'Aba*, pls. i, ii.

Masons' graffiti, id. ib. fig. 3, p. 4.

Pyramid-texts. Id. ib. pls. iii-xvi, figs. 4-6, pp. 4-20; Introduction to Chapter 99 of Book of the Dead, see KEES, *Göttinger Totenbuchstudien* [etc.] in *Miscellanea Academica Berolinensia*, ii [2] (1950), pp. 77-96.

K. PYRAMID-COMPLEX OF PEPY II.  or  

Dyn. VI

Plan XLIV

JÉQUIER, *Le Monument funéraire de Pepi II* (hereafter JÉQUIER), i, ii, iii; id. *Douze ans*, pp. 30-75. Plan, JÉQUIER, iii, pl. 1.

VALLEY TEMPLE.

JÉQUIER, iii, pp. 1-8; id. *Douze ans*, pp. 69-72; id. in *Ann. Serv.* xxvi (1926), pp. 61-2; xxvii (1927), p. 54; xxviii (1928), pp. 56-7; xxxvi (1936), pp. 16-17. Plan, JÉQUIER, iii,

pls. 2, 10; id. *Douze ans*, fig. 21. Reconstruction, JÉQUIER, iii, fig. 5; id. *Douze ans*, fig. 22; LAUER, *Problème*, fig. 19; id. *Mystère*, fig. 21. View, JÉQUIER, iii, pls. 3, 11, fig. 1.

Fragments of reliefs, including King hunting in marshes, divinities, and officials, id. ib. pls. 4-9; of painted scenes, figs. 2-4.

Two panels, [King] crowned by Horus and Sêth, and cartouche upheld by two Horus Bêhdetite hawks, gold-cased wood, probably from box, in Cairo Mus. JE 52021, 52343. Id. ib. figs. 27-8, p. 39 [7, 8]; id. in *Ann. Serv.* xxviii (1928), pl. iv, p. 57.

CAUSEWAY. All scenes much destroyed.

JÉQUIER, iii, pp. 8-17; id. in *Ann. Serv.* xxvii (1927), pp. 54-5. View, JÉQUIER, iii, figs. 6, 7.

(1) and (2) Registers, I, III, divinities, II, IV, bound captives.

Reconstruction, JÉQUIER, iii, pl. 12; fragments, pls. 13, 14 (including remains of adjoining recording of booty), p. 10.

(3) and (4) King as sphinx and as griffin trampling on enemies (at least four times).

Reconstruction, JÉQUIER, iii, pls. 15, 16; fragments, pls. 17, 18, pp. 11-12.

(5) and (6) King on throne decorated with Nile-gods, followed by *ka*, and before him, four registers of divinities, estates, and offering-bringers, and behind him, four registers of officials.

Reconstruction, JÉQUIER, iii, pls. 19, 24; fragments, pls. 20-3, 25-8, pp. 14-16. Names of estates, JACQUET-GORDON, *Domaines*, pp. 183-99 [1R6], cf. fig. 9.

MORTUARY TEMPLE. All scenes much destroyed.

JÉQUIER, ii, passim; iii, pp. 17-26; id. in *Ann. Serv.* xxvii (1927), pp. 55-9; xxviii (1928), pp. 57-9; xxix (1929), pp. 150-2; xxxiv (1934), pp. 79-81. Plan, JÉQUIER, ii, pl. 1 (west part); iii, pl. 29; id. *Douze ans*, fig. 16; id. in *Ann. Serv.* xxvii (1927), pl. ii; xxviii (1928), pl. i; LAUER, *Problème*, fig. 32. View, JÉQUIER, ii, pl. 2; iii, pls. 44, 46; id. *Douze ans*, fig. 9; id. in *Ann. Serv.* xxviii (1928), pl. ii; CAPART, *Memphis*, figs. 106, 108.

I. Passage with Transverse Corridor.

(7) and (8) King embraced by two divinities.

Fragments, JÉQUIER, iii, pl. 38, p. 22 (as pl. 37).

(9) and (10) King, followed by *ka*, slaying captives.

Reconstruction of one scene, id. ib. pl. 36; fragments, pl. 37, p. 22 (as pls. 38-9).

II. Vestibule to Court. Fragments, id. ib. pls. 39-43.

(11) and (12) Either side of doorway, probably King and goddess. See id. ib. p. 21.

(13) Remains of scenes, including one with goddess and fowling-scene with two Queens. Fragments, id. ib. on pls. 41, 43, p. 21 (as pl. 42 in note 2).

(14) King, 1, followed by *ka*, with Pepysonb, Pepy^cankh, Assistant of Duau, and Pepy-nakht, 2, in boat, followed by *ka*, spearing hippopotamus, with another dragged on sledge, and sons and officials.

1, reconstruction, id. ib. pl. 30; fragments, pl. 31, p. 20. 2, reconstruction, id. ib. pl. 32; fragments, pls. 33-5, pp. 20-1.

(15) and (16) Registers of divinities. See id. ib. p. 21.

III. Pillared Court. View, id. ib. pl. 44.

(17) Pillar, quartzite, with scenes on two faces, King embraced by (a) Rēc-Haremakhet, (b) god (head destroyed). Id. ib. pl. 45, fig. 9, pp. 23-4; id. in *Ann. Serv.* xxvii (1927), pl. iii, p. 56. (a) ROBICHON and VARILLE, *En Égypte* (1937), pl. 36.

IV. Central Transverse Corridor. View, JÉQUIER, ii, fig. 1.

Fragments, id. ib. pls. 22-9, 32 [left], pp. 22-4.

(18) (right to left) King, 1, followed by *ka* and officials (including Neni-pepy ) Hereditary prince, Embalmer of Anubis), slaying Libyan captive, with booty, and Khutiotes, Wesa, and Weni supplicating,¹ 2 and 6, running towards Upper Egyptian Mert in *heb-sed* scene, 3, embraced by Hathor, 4, watching erecting of *sehent*-pole with climbing Libyans, and officials and gods (including Min), 5, embraced by goddess, 7, before Nekhbet.

1-3, reconstruction, id. ib. pl. 8; fragments, pls. 9-11, pp. 13-17. Libyans supplicating in 1, HÖLSCHER (W.), *Libyer und Ägypter*, Abb. 1. Reconstruction of 4-7, JÉQUIER, ii, pl. 12; of 4, id. *Douze ans*, fig. 15; fragments of 4-7, JÉQUIER, ii, pls. 13-17, pp. 17-21; of 4, id. in *Ann. Serv.* xxvii (1927), pl. iv, pp. 56-7.

(19) (left to right) King, 1, possibly running (fragmentary), 2, embraced by god, 3, running in *heb-sed* scene, 4, before Buto.

Fragments of 1, JÉQUIER, ii, pl. 21, p. 22. Reconstruction of 2-4, id. ib. pl. 18; fragments, pls. 19, 20, p. 21.

V. Staircase Niche. View, id. ib. fig. 2.

(20) and (21) Young King, supported by god, suckled by goddess in presence of another god.

Reconstruction, id. ib. pls. 30, 32; fragments, pls. 31, 33, p. 24.

VI. Hall with Niches. View, id. ib. pl. 34.

(22) and (23) King slaying captive. Fragments, id. ib. pl. 35, p. 25.

(24) (a)-(e) Niches. Names on granite lining of one, id. ib. p. 25.

VII. Vestibule.

(25) Left thickness of doorway. Remains of two registers, Khenu , Chief Justice [and Vizier], and Pepyankh, Chief lector-priest. Id. ib. pl. 45 [right], p. 31.

(26) Fowling scene. Fragments, id. ib. pl. 107, fig. 6, pp. 32-3.

(27) King, followed by *ka* and goddess, slays antelope before god, with animals in desert. Reconstruction, id. ib. pl. 41; fragments, pls. 42-3, cf. 108 [lower], pp. 31-2.

(28) (from left to right) King, 1 (above doorway), double-scene, with Buto, and with Nekhbet, 2, slays captives, followed by *ka*, with small scenes on right, captives brought by god, with others supplicating, Seshet writing, and goats, donkeys, and sheep, 3, with Buto receives life from Nekhbet.



Reconstruction, id. ib. pl. 36; of 2, id. *Douze ans*, fig. 17; fragments, JÉQUIER, ii, pls. 37-40, figs. 3-5, pp. 26-31.

(29) Granite doorway with names on jambs (lintel missing), and right of it, three registers, each with Anubis.

Reconstruction, id. ib. pl. 44; fragments, pl. 45 [left], pp. 33-4.

¹ For parallel scenes in Mortuary Temple of Sahurēc at Abūšīr and Temple T of Taharqa at Kawa, see *Bibl.* iii² Pt. 1, p. 329 note 1.



VIII. Antechamber. Names, SMITH (W. S.) in REISNER, *Tomb Development*, pp. 395-6.

(30) Registers before King followed by attendants, **I**, Upper Egyptian gods (Sêth, Khnum, and Monthu remain), **II-IV** (lost), **V**, officials (including Idi , Chief Justice and Vizier, etc., Khui , Overseer of Upper Egypt, etc., Impy (Gîza tb. G 2381A), Imapepy .

Reconstruction, JÉQUIER, ii, pl. 46; fragments, pls. 47-9, pp. 35-9. Antef, Imapepy, and Khuenptah in **V**, id. *Douze ans*, fig. 18.

(31) Registers before King, **I-III**, Upper Egyptian gods (including Nekhbet, Sêth, Min, and Souls of Nekhen), **IV**, butchers, **V**, officials.

Reconstruction, JÉQUIER, ii, pl. 50; fragments, pls. 51-3, pp. 39-45. Baboons and goddess in **I**, id. in *Egyptian Religion*, ii (1934), fig. on p. 83.

(32) Registers, **I-II**, Lower Egyptian gods (including Duawêr, Hêķes, and Hêp̄ep  , **III** (destroyed), **IV**, butchers, **V**, officials.

Reconstruction, JÉQUIER, ii, pl. 58; fragments, pls. 59, 60, pp. 49-53. Divinities in **II**, see KEES in *A.Z.* 77 (1941), p. 25; GARDINER in *J.E.A.* 30 (1944), p. 29 note 4.

(33) Above doorway, King followed by Anubis receives life from Nekhbet, granite jambs with names, and right of doorway, registers, **I** (destroyed), **II-III**, Lower Egyptian gods (including Souls of Horus and Souls of Sêth), **IV**, butchers, **V**, officials (including Ihykhent , Chief Justice and Vizier, Neheri, and Khnemhotp).

Reconstruction, JÉQUIER, ii, pl. 54; fragments, pls. 55-7, pp. 45-9.

IX. Sanctuary.

(34) Registers, **I-IV**, offerings, **V-VII**, butchers.

Reconstruction, id. ib. pl. 97; fragments, pls. 98-104, pp. 64-5. Butcher (= pl. 98 [top right]), in Bay Colln.; see Zürich. *5000 Jahre*, p. 62 [134] (incorrectly as Geneva, Musée d'Art et d'Histoire).

(35) and (36) King, followed by *ka*, at table, with offering-list, and registers, **I-IV**, offerings, **V-VI**, offering-bringers, and in **VII** under whole scene, Nile-gods binding *sma*-symbol (on pedestal of throne), personifications, and offering-bringers.

(35) Reconstruction, JÉQUIER, ii, pls. 61-2; fragments, pls. 63-80, pp. 56-64. Block with head, probably from here, in Cambridge, Fitzwilliam Mus. E.182.1939. (36) Reconstruction, id. ib. pls. 81-2; fragments, pls. 83-96. Offering-bringers (= on pl. 90), in Cairo Mus.; id. in *Ann. Serv.* xxviii (1928), pl. iii, p. 58; SMITH, *Hist. Eg. Sculp.* pl. 54 [c], p. 204; id. *Art . . . Anc. Eg.* pl. 50 [B], p. 76; heads, ALDRED, *O.K. Art*, pl. 64; id. *Egypt*, fig. 97.

Various relief-fragments. Original position unknown.

JÉQUIER, ii, pls. 105-9; fragments with solar barks (= on pl. 105), HASSAN, *Gîza*, vi [1], fig. 37, pp. 86-7.

Hieratic graffiti of visitors.

Year of 31st census [of Pepy II], JÉQUIER, ii, fig. 9, p. 69. Two, Amenemhab, Craftsman, and adoration of Hap̄i, both Dyn. XVIII, id. ib. fig. 7, p. 66. Year 37 [of Ramesses II], id. ib. fig. 8, p. 66. On loose block, New Kingdom, JÉQUIER, iii, fig. 33, p. 43.

Statues and statuettes.

Kneeling bound captives; JÉQUIER, iii, pls. 47-8, pp. 27-9. Statue (= pl. 47 [right]) in Cairo Mus. JE 51729; JÉQUIER, *Douze ans*, fig. 20; CAPART, *Documents*, ii, pl. 22; id.



L'Art ég. ii, pl. 265; VON BISSING, *Äg. Kunstgeschichte*, Taf. lxx [395], *Text*, ii, p. 57; HORNE-MANN, *Types*, iii, pl. 578. Statue (= pl. 47 [left]) in Cairo Mus. JE 53670. Two heads, in Cairo Mus. CG 51730-1. Head (not published by Jéquier), in Los Angeles County Mus. 47.12; BREASTED (Jr.) in *Bulletin. Art Division. Los Angeles County Mus.* i [2] (1947), fig. 4, p. 7; *Illustrated Handbook of the Los Angeles County Museum of Art* (1965), fig. in p. 18.

Pepy II as squatting naked child, alabaster, in Cairo Mus. JE 50616. JÉQUIER, iii, pl. 49, pp. 30-1 [1]; id. *Douze ans*, fig. 19, p. 63; id. in *Ann. Serv.* xxvii (1927), pl. v, p. 60; CAPART, *Memphis*, fig. 168; VON BISSING, *Äg. Kunstgeschichte*, Taf. lxx [399]; SCHARFF in *J.E.A.* 26 (1940), pl. ix [4], p. 49; EDWARDS, *Pyramids* (1947), pl. 13 [a]; (1961), pl. 24; STEINDORFF, *A Royal Head*, pl. 29, p. 24 with note 28; TZARA and SVED, *L'Égypte face à face*, pl. on p. 78; HORNE-MANN, *Types*, ii, pl. 500; PIRENNE, *Hist. civ.* i, pl. 88 facing p. 269. See *Descr. somm.* No. 6000.

Cache of statuettes. Middle Kingdom unless otherwise stated.

Ameny , Overseer of the Temple of the Pyramid of Pepy II, etc., block-stature, quartzite, in Cairo Mus. JE 51481. JÉQUIER, iii, pl. 50 [left], fig. 13, pp. 32-3 [4]; HORNE-MANN, *Types*, ii, pl. 442; BOTHMER in *Brooklyn Museum Annual*, ii-iii (1960-2), fig. 12, p. 30 [xvi].

Merenrē , Honoured by Neferkarē (Pepy II), son of Sit-ḥaṭhor (mother), in Cairo Mus. JE 51170. JÉQUIER, iii, pl. 50 [right], fig. 12, pp. 31-2 [3]; HORNE-MANN, *Types*, i, pl. 139.

Zauemnakht  (headless), son of Sitenkaupth  (woman), and Sit-ḥaṭhor (woman), seated, double-stature, sandstone, in Cairo Mus. JE 51480. JÉQUIER, iii, pl. 50 [middle], fig. 11, p. 31 [2]; HORNE-MANN, *Types*, v, pl. 1194.

Three female statuettes, texts effaced, wood, in Neuchâtel Mus. Eg. 325-7. JÉQUIER, iii, pl. 51, pp. 33-4 [5-7]. Eg. 326-7 (Nos. 5 and 7 of Jéquier), GABUS, *175 ans*, Pt. 2, pls. 8, 9 on pp. 168-9, cf. Pt. 1, p. 55 [18, 19]. Eg. 325 (No. 6), id. *La Collection égyptologique* [etc.] in *Formes et couleurs*, xi [1] (1949), 1st fig.

Female statuette, wood, late Dyn. VI or Middle Kingdom, in Cairo Mus. JE 51482. JÉQUIER, iii, fig. 14, p. 34 [8].

Two male statuettes (one of Neferkarē) and one female, wood, late Dyn. VI or Middle Kingdom. See id. *ib.* pp. 34-5 [9-11] with fig. 15.

PYRAMID. Lepsius, XLI; Perring and Vyse, 9.

Exterior

VYSE, *Operations*, iii, pp. 52-3; *L. D. Text*, i, p. 199; JÉQUIER, i, *passim*. Section, PERRING, *Pyramids*, iii, pl. viii [7]. Views, JÉQUIER, ii, pls. 3, 4; id. *Douze ans*, fig. 10.

North chapel. See JÉQUIER, i, pp. 2-3.

Remains of [offering-bringers before King seated, with *ka* behind], with two Nile-gods binding *sma*-symbol and personifications (including Nepri and Zefa) at bottom, re-used. Id. *ib.* fig. 1, pp. 3-4; id. in *Ann. Serv.* xxxiii (1933), pl. i, pp. 141-2; id. *Douze ans*, fig. 13.

Remains of offerings and head of Soul of Pe. JÉQUIER, i, figs. 2-4, p. 4.

Interior

Plan and section, id. *ib.* fig. 5; id. *Douze ans*, fig. 11; MASPERO in *Rec. Trav.* xii (1892), fig. on p. 55 (repr. *Inscr.* fig. on p. 331). Views of burial chamber, JÉQUIER, i, pl. xxv; id.

Douze ans, fig. 12; PIRENNE, *Hist. civ.* i, pl. 91 between pp. 292-3; MEKHITARIAN, *L'Égypte*, fig. on p. 11; ISKANDER in *Ann. Serv.* liv (1957), pls. i, ii, p. 41; LAUER, *Saqqara*, pl. 150; of Level Passage, GRINSELL, *Eg. Pyramids*, pl. v [a]. See JÉQUIER in *Ann. Serv.* xxxiv (1934), pp. 81-2.

Pyramid-texts.

SETHE, *Pyramidentexte*, i, ii, lines N; iii, pp. 146-63, with plan, disposition on walls, and reconstruction; iv, on pl. at end; MASPERO in *Rec. Trav.* xii (1892), pp. 56 [lower]-77, 93-5, 136-95, pls. i-vi; xiv (1893), pp. 125-52 (repr. *Inscr.* pp. 332 [lower]-458, pls. i-vi); JÉQUIER, i, pls. i-xxviii, figs. 9-15, pp. 15-32.

Sarcophagus, granite. Text, MASPERO in *Rec. Trav.* xii (1892), p. 56 [top] (repr. *Inscr.* p. 332 [top]); WILBOUR MSS. 2 B, 183. See JÉQUIER, i, pp. 11-12, cf. fig. 8.

Fragments of Pyramid-texts. Berlin (East) Mus. 14667; text, *Aeg. Inscr.* i, p. 4. Cairo Mus. CG 1706, 1-10; texts, BORCHARDT, *Denkmäler*, ii, pp. 146-7; of CG 1706, 4, 6, 7, 9, 10, SETHE, *Pyramidentexte*, iii, pp. 161-3. Another (JÉQUIER, i, pl. xiii [lower left]), *Werke ägyptischer Kunst [etc.] (Münzen und Medaillen A.G., Auktion 49, Basel, June 27, 1974)*, No. 17 with fig.

Stone vessels. Fragments and alabaster unless stated otherwise.

JÉQUIER, i, fig. 6, pp. 6, 8; id. in *Ann. Serv.* xxxiv (1934), pp. 97-105 with figs.

Unis. Diorite; id. ib. fig. 12, pp. 103-4 [13].

Pepy I. (a) Mentioning 1st *heb-sed*, in Cairo Mus. JE 65337; id. ib. figs. 3, 4, p. 98 [2]. (b) Mentioning pyramid, fragments found by Maspero in 1881, in Cairo Mus. CG 5021-2, and by Jéquier, in Cairo Mus. JE 65339; complete text, id. ib. xxxv (1935), p. 160; CG 5021, PETRIE Giza photo. 517 [left]; JE 65339, JÉQUIER in *Ann. Serv.* xxxiv (1934), figs. 11, 13, pp. 102-3 [12] (as fig. 12 in text); texts of CG 5021-2, REISNER, *Canopics*, pp. 399-400; GAUTHIER, *Livre des Rois*, i, p. 155 [xx]; see MASPERO, *Guide to the Cairo Museum* (1903), p. 472 [58].

Merenrē I. (a) Mentioning pyramid, fragments found in 1881 (Maspero) and 1898, in Cairo Mus. CG 5020, and by Jéquier, in Cairo Mus. JE 65341; text, JÉQUIER in *Ann. Serv.* xxxv (1935), p. 160; of JE 65341, id. ib. xxxiv (1934), pp. 99-100 [5], cf. fig. 8; of CG 5020, REISNER, *Canopics*, p. 399; id. in *Ä.Z.* xxxvii (1899), p. 61 (both inaccurate); GAUTHIER, op. cit. p. 166 [xiii] with note 1. (b) Cairo Mus. JE 65344; JÉQUIER in *Ann. Serv.* xxxiv (1934), fig. 10, p. 101 [7].

Pepy II. Mentioning pyramid, in Cairo Mus. JE 65338; id. ib. figs. 1, 2, pp. 97-8 [1]. (b) Cairo Mus. JE 65343; see id. ib. p. 102 [9]. (c) Cairo Mus. JE 62955.

Jar with text giving contents, in Cairo Mus. JE 65340, completed by fragment found by Maspero in 1881, in Cairo Mus. CG 5019. Id. ib. figs. 6, 7, p. 99 [4]; text, LUCAS and ROWE in *Ann. Serv.* xl (1940), pp. 86 [5], 78 [v] with note 1. CG 5019, see REISNER, *Canopics*, p. 399 (as canopic-jar).

Jar with *serekh*, in Cairo Mus. JE 65342; JÉQUIER in *Ann. Serv.* xxxiv (1934), fig. 9, p. 100 [6].

Possibly from here:

Cylindrical vases of Pepy II, alabaster. (a) With lid, in Brit. Mus. 4492; BUDGE, *A History of Egypt*, ii, fig. on p. 116; RANKE, *The Art of Ancient Egypt*, and BREASTED, *Geschichte Aegyptens* (1936), 281 [middle]; HAY MSS. 29816, 207 [upper]; see *Guide, 4th to 6th*, p. 15 [11] (No. 4492 on pl. ii is really No. 4493). (b) Formerly in Bankes Colln., now in Brit.

Mus. 22817; *Guide, 4th to 6th*, on pl. ii, p. 15 [12]; *Guide, Eg. Collns.* (1930), on fig. 160, p. 302; HALL, *Egypt in Encyclopaedia Britannica*, 14th ed. (1929), pl. iv [4]; WILKINSON MSS. xxiii. 152 [top]; HAY MSS. 29816, 207 [upper]. (c) With lid, formerly in Abbott and N.Y. Hist. Soc. Collns., now in Brooklyn Mus. 37.69E; PRISSE, *Mon.* xlix [5]; id. in *Rev. Arch.* ii (1845-6), fig. on p. 734 [lower left]; *L. D. Text*, i, fig. on p. 6 [1]; *N.Y.H.S. Cat.* (1915), No. 705 with fig. (marked 702); RIEFSTAHL, *Toilet Articles from Ancient Egypt*, pl. 3 [lower, middle left and left]; *Eg. Art . . . Brooklyn*, fig. 23 [left]; NESTOR L'HÔTE MSS. 20396, 205; WILKINSON MSS. xx. A. 11 [top]; text, GAUTHIER, *Livre des Rois*, i, p. 173 [xv] (as Brit. Mus.); JAMES, *Corpus*, i, pl. xxvi [69], p. 29. (d) Formerly Pier Collection; see PIER, *The Garrett Chatfield Pier Collection* [etc.], Sale Cat. (1936), p. 16 [66, 2nd item].

SUBSIDIARY PYRAMID.

View, JÉQUIER, ii, pls. 5, 6, p. 8; id. *Douze ans*, fig. 14; LAUER, *Saqqara*, pl. 149. See JÉQUIER in *Ann. Serv.* xxvii (1927), p. 59.

PYRAMID-ENCLOSURE OF NEIT¹ Dyn. VI













JÉQUIER, *Les Pyramides des reines Neit et Apouit* (hereafter JÉQUIER), pp. 3-40, with plans, pl. i [lower], ii; id. in *Ann. Serv.* xxxi (1931), pp. 36-42, with plan, fig. 2; id. *Douze ans*, pp. 76-83, with plan, fig. 23 [lower]. View, JÉQUIER, pl. iii. Plan of priests' dwellings, id. in *Ann. Serv.* xxxvi (1936), figs. on p. 18, cf. p. 19.

MORTUARY TEMPLE. View of Sanctuary, JÉQUIER, pl. vi [upper], pp. 9-10.

Entrance doorway.

Two obelisks (one incomplete) with titles, mentioning pyramids of Pepy I, Merenrē I, Pepy II. Id. ib. fig. 1, p. 4; text, id. in *Studies presented to F. Ll. Griffith*, p. 10.

Jamb with remains of figure of deceased. See JÉQUIER, pp. 3-4.

Protective decree for priests of Neit and 'Ankhnemeryrē            , year of the 'Union of the Two Lands', end of Dyn. VI, in Cairo Mus. JE 56370. Id. ib. fig. 2, p. 5; id. in *Ann. Serv.* xxxi (1931), fig. 3, pp. 38-9; GOEDICKE, *Königliche Dokumente aus dem Alten Reich*, Abb. 15, pp. 158-62; text, SETHE, *Urk.* i. 307 [38 (178)].

'Salle des Lions'.

Remains of scene (repeated three times), male and female attendants in front of [deceased and goddess] on dais with lions and *sma*-symbol. JÉQUIER, pls. iv [upper], v [middle and bottom], pp. 6-7.

Blocks with head of deceased and titles. Id. ib. pls. iv [bottom], v [top], p. 7; NEWBERRY in *J.E.A.* 29 (1943), pp. 53-4 with fig. (from JÉQUIER).

Pillared Court.

Remains of scenes with deceased offering. JÉQUIER, fig. 3, p. 8.

PYRAMID.

Views of burial chamber, id. in *Ann. Serv.* xxxi (1931), pl. i, pp. 41-2; id. *Douze ans*, fig. 24.

Pyramid-texts. JÉQUIER, pls. vii-xxxii, figs. 6-8 (disposition on walls), pp. 12-28.

Jar of Pepy I, alabaster, fragments, in Cairo Mus. JE 57424. Id. ib. fig. 15, pp. 31-2.

¹ King's daughter (of Pepy I), King's wife (of Merenrē I and Pepy II), etc.

Disks of Pepy II, schist and alabaster, in Cairo Mus. JE 58342-5, and cups of deceased, diorite (one, mentioning *heb-sed*, JE 58346). Id. ib. fig. 12, p. 31.

SUBSIDIARY PYRAMID. View, id. ib. pl. vi [lower], pp. 10-11.

Cup with offering-text, alabaster, in Cairo Mus. JE 58347. Id. ib. fig. 4, p. 10; text, id. in *Ann. Serv.* xxxiv (1934), p. 108.

Sixteen model boats with accessories, wood, in Cairo Mus. JE 56386-97. JÉQUIER, pls. xxxiii-xxxv, figs. 17-21, pp. 33-40, 11; POUJADE, *Trois flottilles de la vi^{ème} Dynastie des Pharaons*, pls. i-iv, figs. 1-12, pp. 7-23.

PYRAMID-ENCLOSURE OF IPUT II¹ . Dyn. VI

JÉQUIER, *Les Pyramides des reines Neit et Apouit* (hereafter JÉQUIER), pp. 41-8, with plans, pls. i [upper], xxxvi; id. in *Ann. Serv.* xxxi (1931), pp. 42-3; id. *Douze ans*, pp. 83-7, plan, fig. 23 [upper]. View, JÉQUIER, pl. xxxvii.

MORTUARY TEMPLE.

Entrance doorway.

View, id. in *Ann. Serv.* xxxi (1931), pl. ii, pp. 42-3; id. *Douze ans*, fig. 25; LACOUTURE in *Egypt Trav. Mag.* No. 20 (March 1956), figs. on p. 23.

Two obelisks (one incomplete), with name of Pyramid of Pepy II and titles. JÉQUIER, fig. 24, p. 43; cf. id. in *Studies presented to F. Ll. Griffith*, p. 11.

Lintel with dedication of Pepy II, jambs with titles, granite. JÉQUIER, figs. 22, cf. 23, pp. 41-3; text of lintel, id. in *Studies presented to F. Ll. Griffith*, p. 11; SETHE, *Urk.* i. 271-2 [26 (166), A].

North Chapel.

Block with offerings, JÉQUIER, fig. 25, p. 47.

Hieratic graffito. Id. ib. fig. 26.

PYRAMID.

Thirty-one fragments of Pyramid-texts, id. ib. pls. xxxviii, xxxix, p. 47.





Sarcophagus, granite, fragments. Name, id. ib. p. 46.

PYRAMID-ENCLOSURE OF WEZEBTEN² . Dyn. VI

JÉQUIER, *La Pyramide d'Oudjebten* (hereafter JÉQUIER); id. *Douze ans*, pp. 87-92; id. in *Ann. Serv.* xxvi (1926), pp. 48-55. Plan, JÉQUIER, pl. i. View, id. ib. pls. ii, v; id. *Douze ans*, fig. 26; id. in *Ann. Serv.* xxvi (1926), on pl. i.

VESTIBULE.

Entrance doorway. Lintel with titles, mentioning Pyramid of Pepy II, found in Mortuary Temple of Pepy II, in Cairo Mus. JE 51732. JÉQUIER, fig. 26, p. 21.

South-east doorway. Lintel with titles and name, jambs and right thickness with names of Inspectors of prophets of her (i.e. Wezeten's) funerary estate, Ikhi , his two sons S^cankhenptah  and Hem^cankh  Hemi , and Ikri , son of Hem^cankh, temp. Pepy II, in Cairo Mus. JE 49681. Id. ib. figs. 27-8, pp. 22-3; id. in *Ann. Serv.* xxvi (1926), fig. 1, p. 54; text, SETHE, *Urk.* i. 272-3 [27 (167), A].

¹ King's daughter, King's wife (of Pepy II), etc.

² King's wife (of Pepy II), etc.

ENCLOSURE.

Doorway in north wall. Lower part of jambs with name and titles, sandstone, JÉQUIER, pl. xiii [1], figs. 3, cf. 4, pp. 9-10.

MORTUARY TEMPLE.

Relief-fragments, including double-scene with deceased before god and goddess, female attendants, lions on dais of throne, etc. Id. ib. figs. 8-13, pp. 15-16.

Sanctuary.

Fragment of jambs of false-door (right part now in Cincinnati (Ohio), Art Mus. 1974.413; *Bulletin*, 10 [4] (June 1976), fig. on p. 26). Id. ib. fig. 6, p. 13.

Altar, alabaster. Id. ib. pl. xiii [2], fig. 7, pp. 14-15; id. in *Ann. Serv.* xxvi (1926), pl. v, p. 51.

Block with two groups of butchers. JÉQUIER, fig. 14, p. 16.

PYRAMID. Lepsius, XLII.

See *L. D. Text*, i, p. 199. Section and reconstruction (with Mortuary Temple), JÉQUIER, figs. 1, 5. Views of interior, id. ib. pls. iii, iv; id. in *Ann. Serv.* xxvi (1926), pls. iii, iv, pp. 49-50.

Pyramid-texts. JÉQUIER, pls. vi-xii, pp. 5-8; id. *La Pyramide d'Aba*, pls. xxiii-xxix, pp. 36-8.

Finds from Pyramid-enclosure

Protective decree of Pepy II for Wezebtan, year of 33rd census, naming priests (including Ikri), six fragments. JÉQUIER, fig. 17, p. 18; GOEDICKE, *Königliche Dokumente aus dem Alten Reich*, Abb. 13 (from JÉQUIER), p. 155.

Fragments of text mentioning pyramidion, of jamb with text of building of temple by deceased, and of inscribed stone coffer. JÉQUIER, figs. 15, 16, 18, 19, pp. 16, 18-19; texts, SETHE, *Urk.* i. 272 [26 (166), B].



Fragment of vase with name of Pyramid of Pepy II, alabaster, in Cairo Mus. JE 49838. JÉQUIER, fig. 25 [right], p. 20 with note 3.

Fragments of cup with mention of 1st *heb-sed*, diorite, in Cairo Mus. JE 49841. Id. ib. fig. 25 [left], p. 20 with note 4.

SUBSIDIARY BUILDINGS. Late Old Kingdom.

Fragments of jambs of Ameny , Overseer of the store-room. Id. ib. fig. 29, pp. 23-4; text, SETHE, *Urk.* i. 273 [27 (167), B].

Fragment of left jamb of Rud , with son Ikri, Scribe of a phyle, and two women. JÉQUIER, fig. 30, p. 24; text, SETHE, *Urk.* i. 273-4 [27 (167), C].

L. BURIAL-COMPLEX OF SHEPSESRAF.  .

Dyn. IV

JÉQUIER, *Le Mastabat Faraoun* (hereafter JÉQUIER); id. *Douze ans*, pp. 13-25; id. in *Ann. Serv.* xxv (1925), pp. 61-71; xxvi (1926), pp. 44-8; *L. D. Text*, i, pp. 199-201. Plan, JÉQUIER, frontispiece; id. in *Ann. Serv.* xxv (1925), fig. 4 on p. 68. Reconstruction, JÉQUIER, fig. 2; id. *Douze ans*, fig. 7.

CAUSEWAY. View, id. ib. fig. 8; JÉQUIER, pl. x.

MORTUARY TEMPLE.

Plan, id. ib. pl. vi, fig. 8; id. in *Ann. Serv.* xxv (1925), fig. 3, pp. 65-6. View, JÉQUIER, pls. vii [1], viii, cf. ix. Description, BURTON MSS. 25618, 27.

Fragments of inscribed seat of statue of deceased, dolerite, in Cairo Mus. JE 52160-2. JÉQUIER, fig. 12, p. 21; see GUNN in *Ann. Serv.* xxix (1929), p. 92.

SARCOPHAGUS-SHAPED TOMB. Lepsius, XLIII; Mariette, D 66; Maştabet Faraʿûn.

Plans and sections, MARIETTE, *Mastabas*, figs. on pp. 361-5; JÉQUIER, pl. ii, fig. 3; id. *Douze ans*, fig. 5. Section, id. in *Ann. Serv.* xxv (1925), fig. 2, pp. 63-4; PERRING, *Pyramids*, iii, pl. viii [8].

Views, L. D. i. 37; MARIETTE, *Voyage*, i, pl. 4, pp. 33-4; PERROT and CHIPIEZ, *Hist. de l'Art*, i, fig. 109; MASPERO, *Hist. anc.* i, fig. on p. 417; id. *L'Arch. ég.* (1887), fig. 137; (1907), fig. 143; CAPART, *L'Art ég.* (1911), pl. 105; id. *L'Art ég.* i, pl. 43; id. *Memphis*, fig. 109; HALL, *The Ancient History of the Near East*, pl. viii [3]; JÉQUIER, fig. 1, cf. pls. v, vii [2], xi; id. *Douze ans*, figs. 3, cf. 4; id. in *Ann. Serv.* xxvi (1926), pls. ii, cf. i; VON BISSING, *Äg. Kunstgeschichte*, Taf. xxv [214]; HELCK, *Geschichte des alten Ägypten*, Taf. ii [6]; LAUER, *Saqqara*, pl. 147; of interior, id. ib. pl. 148; JÉQUIER, pls. iii, iv; id. *Douze ans*, fig. 6.

Five fragments of restoration-text of Kha'emwëset (son of Ramesses II). JÉQUIER, fig. 7, p. 13; text, DRIOTON in *Ann. Serv.* xxxvii (1937), pp. 205-10 [B]; GOMAA, *Chaemwese* [etc.], Abb. 4, 5-6, p. 77 [12]; see JÉQUIER in ib. xxvi (1926), p. 45.

Masons' graffiti. BORCHARDT in *O.L.Z.* xxxiv (1931), cols. 401-2 with pl.; see xxxii (1929), col. 73; JÉQUIER, p. 5.

M. PYRAMID-ENCLOSURE OF USERKARĒ KHENZER



JÉQUIER, *Deux pyramides du Moyen Empire* (hereafter JÉQUIER), pp. 1-38; id. *Douze ans*, pp. 140-9; id. in *Ann. Serv.* xxix (1929), pp. 153-6; xxx (1930), pp. 105-7; xxxi (1931), pp. 32-5; L. D. Text, i, p. 202 [XLIV]. Plan, JÉQUIER, pls. i [upper], ii; id. *Douze ans*, fig. 40. View of structures inside enclosure, JÉQUIER, pls. iv, ix [b].

MORTUARY TEMPLE. Destroyed.

View with fragment of inscribed granite jamb; id. ib. pl. iii [upper], p. 3.

Relief-fragments, with upper part of god, and royal names and titles; id. ib. figs. 1-4, pp. 3-5.

Fragments of columns with cartouches, in Cairo Mus. JE 56371-5; one, id. ib. fig. 5, pp. 5-6.

Hieratic graffiti. Years 1, 3, and 4 (of Khenzer); id. ib. figs. 8-11, pp. 10-14; transcription of some, HELCK, *Historisch-biographische Texte*, p. 6 [11]. Nashwuy Scribe, mentioning Pyramids of Teti and Zoser, year 34 (of Ramesses II); JÉQUIER, fig. 12, pp. 14-15 (transcription by Černý). Another, id. ib. fig. 13, p. 15.

PYRAMID. Lepsius, XLIV.

Views, id. ib. pls. iii [lower], vii; plans and sections, pl. viii; id. in *Ann. Serv.* xxix (1929), pl. i, p. 154.

Brick with painted date of year 1 (of Khenzer); JÉQUIER, figs. 22-3, p. 29.

Pyramidion, inscribed, with Rē-Ḥarakhti, Atum, and solar-barks on east face, granite,

Pyramid-enclosure of Userkarē Khenzer

restored, in Cairo Mus. JE 53045. Id. ib. pl. vi, figs. 16–20, pp. 19–26; id. *Douze ans*, fig. 41; id. in *Ann. Serv.* xxx (1930), pl. ii, pp. 105–6; ARCH. LACAU phot. O. i, 1; barks, HASSAN, *Gîza*, vi [1], fig. 66 (from JÉQUIER), pp. 147–8; see *Descr. somm.* No. 6175.

Fragment of canopic-jar of Seneb[hena's] , King's wife (possibly of Khenzer), alabaster, found south of Pyramid, in Cairo Mus. JE 54498. JÉQUIER, fig. 21, p. 28.

NORTH CHAPEL. Destroyed. View, id. ib. pl. v [a].

Fragments of quartzite false-door and remains of offering-list, offering-bringers, and names; id. ib. figs. 14, 15, pp. 15–18.

Bust of statuette (of Khenzer), granite, in Cairo Mus. JE 53668; id. ib. pl. v [b, c], pp. 18–19; id. *Douze ans*, fig. 42; HORNEMANN, *Types*, iii, pl. 733 (as basalt); EDWARDS, *Pyramids* (1961), pl. 30 [b]; see JÉQUIER in *Ann. Serv.* xxx (1930), pp. 106–7 (as diorite); *Descr. somm.* No. 6176 (as basalt).

SUBSIDIARY PYRAMID. View of entrance, JÉQUIER, pl. ix [a].

Plan and sections of interior, id. ib. figs. 26–8; id. in *Ann. Serv.* xxxi (1931), fig. 1, pp. 33–5.

N. PYRAMID-ENCLOSURE OF DYNASTY XIII

JÉQUIER, *Deux pyramides du Moyen Empire* (hereafter JÉQUIER), pp. 55–68; id. *Douze ans*, pp. 149–55; id. in *Ann. Serv.* xxx (1930), pp. 107–11. Plan, JÉQUIER, pls. i [lower], xiii; id. *Douze ans*, fig. 43. Views of brick-built undulating enclosure wall, JÉQUIER, pl. xv; id. *Douze ans*, fig. 45; id. in *Ann. Serv.* xxx (1930), pl. iii [upper].

PYRAMID. Lepsius, XLVI.

Views, JÉQUIER, pls. xiv, xix, xx, cf. fig. 43; id. *Douze ans*, fig. 44; GRINSELL, *Eg. Pyramids*, pl. xii. Plans and sections of interior, JÉQUIER, pls. xvii, xviii; id. in *Ann. Serv.* xxx (1930), pl. i, pp. 109–10; LAUER, *Mystère*, fig. 34.

Two pyramidia, uninscribed, unfinished, granite, in Cairo Mus. JE 54855–6; JÉQUIER, pl. xvi, fig. 42, pp. 58–60; id. in *Ann. Serv.* xxx (1930), pl. iii [lower], p. 109.

Hieratic graffiti. JÉQUIER, figs. 46–7, p. 63. Transcription of some, HELCK, *Historisch-biographische Texte*, pp. 9–10 [14].

II. Necropolis

Plans, DE MORGAN, *Carte de la Nécropole Memphite*, 5–10; L. D. i. on 32–3; of north part, SMITH (W. S.) in REISNER, *Tomb Development*, 2nd map at end; SPENCER in *Orientalia*, n.s. 43 (1974), pl. i facing p. 4; of Early Dynastic tombs, KEMP in *Antiquity*, xli (1967), fig. 4, p. 31. Early Dynastic tombs, see REISNER, op. cit. pp. 383–9; Old Kingdom tombs, see SMITH (W. S.) in ib. pp. 390–411.

A. NORTH OF THE STEP PYRAMID

Maps XLV, XLVI

EARLY DYNASTIC CEMETERY WEST OF VILLAGE OF ABÛŞÏR

BONNET, *Ein frühgeschichtliches Gräberfeld bei Abusir*, with plan, Taf. 1.

10B-2/3. Early Dynastic.

Id. ib. p. 53, with plan and section, on Taf. 2.

Cylinder-seal mentioning Neith, ivory, in Leipzig, *Äg. Mus. Inv.* 2657. Id. ib. Taf. 31 [3, right lower], Abb. 17, p. 47; see KRAUSPE, *Ägyptisches Museum der Karl-Marx-Universität Leipzig* (1976), p. 15 [8/19].



Jar of Tet , *sem*-priest of Neith, schist, in Leipzig, *Äg. Mus. Inv.* 3277. BONNET, op. cit. Abb. 12, cf. Taf. 12 [104], p. 19; MÜLLER (Dieter) and ETZOLDT, *Ägypten*, Taf. 9; KRAUSPE, op. cit. Taf. iv [10/7], p. 17.



EARLY DYNASTIC CEMETERY NORTH AND NORTH-WEST OF THE SERAPEUM

MACRAMALLAH, *Un cimetière archaïque de la classe moyenne du peuple à Saqqarah*, with plans, pls. i, ii, and views, pls. iii, iv.

Sealings of Den. Id. ib. pl. xlvii [1-3], p. 21 [3].

Two pottery vases of Den. Id. ib. pl. xlvii [4], figs. 23-4, pp. 21-2 [4, 5].

Vase of Denes(?)  , Dyn. I. Id. ib. fig. 21, p. 21 [1].

Four ivory labels of Ipka  , Dyn. I, in Cairo Mus. JE 86172-5. Id. ib. pl. xlvi [1], fig. 17, pp. 16-18 [7] with note 4; JE 86174, LACAU and LAUER, *Pyr. à deg.* v, fig. 74 on p. 50.

EARLY DYNASTIC AND OLD KINGDOM TOMBS S 2146-3518

Plan of groups 2100 and 2300, QUIBELL, *Saqqara (1912-1914)*, pl. i, p. 3; view, pl. iii, p. 4; plan of group 2400, pl. ii, p. 4; of tombs along east slope, EMERY, *Great Tombs*, i, pl. 1; ii, fig. 1; iii, pl. 1; LAUER in *B.I.F.A.O.* lv (1955), fig. 1, pp. 156-7.



S 2146E. SEHEFNER  , King's daughter. Dyn. II.

Niche-stela, in Cairo Mus. JE 44135. QUIBELL, *Saqqara (1912-1914)*, pls. xxvi, xxvii, pp. 10, 22; HASSAN, *Giza*, v, fig. 15 (from QUIBELL), pp. 92-7; deceased, BAKER, *Furniture*, fig. 24.

S 2171. Temp. Ninüter or later. Above S 2171H.

QUIBELL, *Saqqara (1912-1914)*, pp. 23-4, with plan of substructure, on pl. xxx, and views, pl. xv [1, 2, 4].

Jar-sealing of Ninüter, in Cairo Mus. Temp. No. 24.12.23.5. Id. ib. pl. xv [3], p. 7; text, NEWBERRY MSS. vi. E.C. 6, 7.

Coffin and cartonnage mask of Pekmes-sethet   , Ptolemaic, intrusive. See QUIBELL, op. cit. p. 24 [top].

S 2171H. Temp. Zer. Covered by S 2171.

QUIBELL, *Saqqara (1912-1914)*, pp. 16-17.

Label with text of Zer, wood, in Cairo Mus. JE 63346. Id. ib. pl. xi [5], pp. 6, 16 [10]; KAPLONY, *Inscripfen, Suppl.* Taf. v [1064], p. 32 (called JE 45024).

Label with text of Zer, ivory, probably in Cairo Mus. QUIBELL, op. cit. pl. xi [2, 3], pp. 6, 16 [1]; VIKENTIEV in *Bull. Inst. Ég.* xxxvi (1953-4), pl. ii [B], figs. 9, 10, pp. 310-13.

S 2185. Temp. Zer or later.

QUIBELL, *Saqqara (1912-1914)*, pp. 15-16, with plan, pl. v, views, pls. vi, vii, and finds, pls. viii-x.

Sealing of Zer. Id. ib. pls. viii [5], ix [top], p. 6.

S 2302. Temp. Ninüter or later.

QUIBELL, *Saqqara (1912-1914)*, pp. 29-30, with plan of substructure, on pl. xxx, and views, pls. xvii [1, 2], xxxi [1, 3].

Stone vessels of Ruaben , Overseer (*mdh*) of sculptors, etc., fragmentary, in Cairo Mus. Two, greywacke, JE 45324-5, id. ib. pl. xvii [4], pp. 8, 30; LACAU and LAUER, *Pyr. à deg.* iv [1], pl. vi [5, 6], p. 6. Limestone, JE 45179, KAPLONY, *Inschriften, Suppl.* Taf. 29 [1076], pp. 34-5.

Sealings of Ninüter, in Cairo Mus. (a) JE 44378, QUIBELL, op. cit. pl. xvii [3], pp. 8, 30 [top]; KAPLONY in *A.Z.* 88 (1963), Abb. 22, pp. 14, 16; NEWBERRY MSS. vi. F.A. 13.1 [middle]. (b) Temp. No. 24.12.23.4, QUIBELL, op. cit. p. 30 [middle]; NEWBERRY MSS. vi. F.A. 13.1 [upper].

S 2305. Temp. Neterikhet (Zoser) or later.

Sealing of Neterikhet, in Cairo Mus. JE 44372 (probably). Name, QUIBELL, op. cit. pp. 3, 30; NEWBERRY MSS. vi. E.C. 8 [left upper].

S 2322. Dyn. II-III.

QUIBELL, *Saqqara (1912-1914)*, p. 34, with plan of substructure, on pl. xxx, and views, pl. xx.

Texts of three sealings, id. ib. p. 34.

S 2331. Dyn. II-III.

Niche-stela, much damaged. Id. ib. pl. xxviii [2], pp. 10, 35.

S 2347. Temp. Userkaf or later.

Offering-basin with text with cartouche of Userkaf, in Cairo Mus. JE 44128. Id. ib. pl. xxviii [3], pp. 11, 36.

S 2400. PTAḤSABU . Dyn. II-III.

Name on jamb of doorway, id. ib. p. 38.

S 2401.

Offering-basin of Ny , Overseer (*mdh*) of sculptors, etc., Dyn. II-III, in Cairo Mus. JE 44131. Id. ib. pl. xxviii [4], pp. 11, 38.

S 2405 [A3]. ḤESYRĒ , Overseer (*mdh*) of the royal scribes, Greatest of physicians and of dentists, Greatest of the Ten of Upper Egypt, etc. Early Dyn. III.

QUIBELL, *The Tomb of Hesy. Excavations at Saqqara (1911-12)*, with plan, pl. i, and views, pls. iii, iv [3], xxiv.

Outer corridor.

West wall. Remains of painted scenes, men with cattle, and crocodile. Crocodile, now in Cairo Mus., id. ib. pl. vii [2], pp. 4, 16.

Limestone hawk, headless, probably from over one of niches on either side of doorway. See id. ib. pp. 4, 9.

Inner corridor. View, id. ib. pl. iv [1].

Doorway. Remains of painted vases and text, id. ib. pl. xxii [upper], p. 36.

East wall (painted). Two registers, **I** (mostly destroyed), magazines with oils, **II**, funerary equipment, including games, tools, weights and measures, furniture, toilet articles, etc.; id. ib. pls. vi, vii [1], x-xv, xvi [right], xvii-xxi, xxii [lower], xxiii, figs. 2-18, pp. 2-3, 5-9, 16-36; snake-game, RANKE, *Das altägyptische Schlangenspiel in Sitzungsberichte der Heidelberger Akademie der Wissenschaften*, Phil.-hist. Kl. 1920 [4], Abb. 1, 2 (from QUIBELL), pp. 3-5.

North wall (painted). Representations of two pottery and two alabaster stands; QUIBELL, pl. xvi [left], p. 18.

West wall with eleven painted niches with stelae. Plan of niche and decoration, id. ib. pls. viii, ix, pp. 4-5, 16-17; view, pl. iv [2].

Six wooden niche-stelae with deceased. In Cairo Museum.

CG 1426-30, from south niches, removed by Mariette, another, from northernmost niche, removed by Quibell. CG 1426-30, BORCHARDT, *Denkmäler*, i, Bl. 25-7, pp. 108-11; QUIBELL, pls. xxix-xxxii, p. 40 (left on pl. xxix called CG 1426); WEILL, *La II^e et la III^e Dynasties*, pl. iii facing p. 231; see MASPERO, *Guide*, p. 48 [88 A-E] with fig. 11 (CG 1426). CG 1426-8, MARIETTE, *Album du Musée de Boulaq* (1872), pl. 12; id. *Mastabas*, figs. on pp. 80-2; PERROT and CHIPIEZ, *Hist. de l'Art*, i, figs. 431, 429, 430; BULLE, *Der schöne Mensch im Altertum* (1898), Taf. 1; MASPERO, *Égypte*, figs. 102, 101; BOREUX, *L'Art ég.* pl. xxviii [a]; PIJOAN, *History of Art*, i, fig. 85; VON BISSING, *Äg. Kunstgeschichte*, Taf. lviii [364], *Text*, i, p. 41; deceased, id. *Denkmäler*, *Text* to Taf. 102 [figs.]; WEIGALL, *Anc. Eg. . . . Art*, 19.

CG 1426, seated at table.¹ KLEBS, *Reliefs . . . a. R.* Abb. 4, p. 7; BREASTED in *A. J. S. L.* xxxii (July 1916), fig. 5, p. 236; FECHHEIMER, *Plastik* (1914), pl. 101 [left]; (1923), pl. 111 [left]; STEINDORFF, *Kunst*, 195 [left]; POULSEN (F.), *Ägyptens Kunst* (1933), fig. 41; CAPART, *L'Art ég.* iii, pl. 408; VANDIER, *Eg. Sculpture*, pl. 2; *Encycl. phot. Caire*, pl. 5; LANGE and HIRMER, *Aegypten. Architektur*, pls. 18 [left], 19; FORMAN (W. and B.) and VILÍMKOVÁ, *Eg. Art*, pls. 2, 3; WOLDERING, *Götter*, Abb. 18; WESTENDORF, *Das Alte Ägypten*, fig. on p. 32; MICHALOWSKI, *Art*, fig. 188; GROENEWEGEN-FRANKFORT and ASHMOLE, *Art of the Ancient World*, fig. 23. Deceased, LANGE, *Äg. Kunst*, pl. 11; id. *Pyramiden, Sphinxe, Pharaonen*, pl. 73 facing p. 184; SMITH, *Hist. Eg. Sculp.* pl. 31 [b], pp. 18, 139-40, 150, 273, 290, 303; HAMANN, *Äg. Kunst*, Abb. 116; ANTHES, *Meisterwerke*, Taf. xxxv; id. *Aeg. Plastik*, Taf. 43; BAKER, *Furniture*, fig. 26, p. 34; HUSSEIN, *Vom Papyrus zum Codex*, pl. on p. 25; BRUNNER-TRAUT, *Die Alten Ägypter*, Taf. 23; VANDERSLEYEN, *Das Alte Ägypten*, Abb. 241. *Text*, CAPART, *Memphis*, fig. 260; id. *Documents*, ii, pl. 33; JONCKHEERE, *Les Médecins de l'Égypte pharaonique*, fig. 21, p. 63; BEEKMAN, *Hout in alle Tijden*, fig. 7.58, p. 504.

CG 1427, standing with *sekhem*-sceptre, and scribe's equipment and staff.¹ FECHHEIMER, *Plastik* (1914), pls. 101 [right], 102; (1923), pls. 111 [right], 112; BREASTED in *A. J. S. L.* xxxii (July 1916), fig. 6, p. 237; STEINDORFF, *Kunst*, 195 [right]; POULSEN (F.), *Ägyptens Kunst* (1933), fig. 40; SCHÄFER, *Von äg. Kunst* (1919), Taf. 1 (frontispiece), 10; (1922 and

¹ Selected references.

1930), Taf. 1, 8; (1963), Taf. 1, 9 [2]; Eng. ed. *Principles of Egyptian Art*, pls. 1, 15; HAMANN, *Äg. Kunst*, Abb. 115, 115a, 187; RANKE, *The Art of Ancient Egypt*, and BREASTED, *Geschichte Aegyptens* (1936), 183; CAPART, *L'Art ég.* iii, pls. 410-11; *Encycl. phot. Caire*, pl. 6; LANGE and HIRMER, *Aegypten. Architektur*, pl. 18 [right]; YOYOTTE, *Treasures*, pl. on p. 15; GILBERT, *Méditerranée antique* [etc.], fig. 13; MICHALOWSKI, *Art*, figs. 67, 186; TERRACE and FISCHER, *Treasures*, pp. 33-6 with pls.; DONADONI, *Egyptian Museum Cairo*, pl. on p. 54; GROENEWEGEN-FRANKFORT and ASHMOLE, *Art of the Ancient World*, fig. 24. Deceased, MITRY, *Illus. Cat.* No. 88; ALDRED, *O.K. Art*, pl. 9; upper part, MEYER, *Aegypten zur Zeit der Pyramidenerbauer*, Taf. 8; BORCHARDT, *Works of Art*, pl. 20; MASPERO and ROEDER, *Führer*, Taf. 9, p. 19 [154]; SCHÄFER and ANDRAE, *Kunst* (1925), 236; (1930 and 1942), 246; CAPART, *Memphis*, fig. 231; COTTEVILLE-GIRAUDET in *B.I.F.A.O.* xxxiii (1933), pl. xvi, p. 152; PIJOÁN, *Summa Artis*, iii (1945), fig. 108; FORMAN (W. and B.) and VILÍMKOVÁ, *Eg. Art*, pl. 1; head, POULSEN, *Äg. Kunst. A. und M.* pl. on p. 36 [upper]. Text, HUSSEIN, *Vom Papyrus zum Codex*, pl. on p. 29 [lower].

CG 1428, standing with scribe's equipment on shoulder. Head or upper part, CAPART, *Les Débuts de l'art en Égypte*, fig. 3; id. *Primitive Art in Egypt*, fig. 3; FORMAN (W. and B.) and VILÍMKOVÁ, *Eg. Art*, pl. 7; *Capolavori*, i, No. 9 (1963), fig. on p. 149 [lower right]; Eng. ed. fig. on p. 141 [lower right]; POULSEN, op. cit. pl. on p. 36 [lower].

CG 1429, standing with *sekhem*-sceptre, scribe's equipment on shoulder, and staff. CAPART, *L'Art ég.* iii, pl. 409. Upper part, *Anc. Eg.* (1915), 1st pl. after p. 48; *Encycl. phot. Caire*, pl. 7; SÉE, *Naissance*, fig. on p. 55. Deceased, SCHÄFER, *Von äg. Kunst* (1963), Taf. 9 [1]; Eng. ed. *Principles of Egyptian Art*, pl. 14; id. in *Ä.Z.* 74 (1938), Abb. 6, p. 29; PIJOÁN, *Summa Artis*, iii (1945), fig. 109.

CG 1430, standing holding staff in front of his chest, with scribe's equipment on shoulder. CAPART, *L'Art ég.* iii, pl. 407. Deceased, PIJOÁN, *Summa Artis*, iii (1945), fig. 110; FORMAN (W. and B.) and VILÍMKOVÁ, *Eg. Art*, pl. 6; upper part, ROSS, *The Art of Egypt*, pl. on p. 113 [right].

Stela removed by Quibell, standing with *hes*-vase. QUIBELL, pl. vii [3], cf. v, p. 16. See MASPERO, *Guide*, p. 48 [88F]; FISCHER in *Metropolitan Museum Journal*, 5 (1972), pp. 17-19, cf. figs. 11, 25.



Substructure.

QUIBELL, pp. 4, 11-13, 37; plan and section, pl. ii; views, pl. xxv.

Two fragments of sealing of Neterikhet. One, in Cairo Mus. JE 44373, id. ib. pl. xxviii [23], pp. 3, 12, 39; text, NEWBERRY MSS. vi. E.C. 8 [left lower].

Handle with name and titles, bone, QUIBELL, pl. xxviii [8, 9], p. 38; another inscribed bone fragment, pl. xxviii [12], p. 38.

S 2407. Dyn. III.

Fragments of stone vessels. (a) Ḥesyrēc , Scribe, diorite, in Cairo Mus. JE 44367, KAPLONY, *Inschriften, Suppl.* Taf. 29 [1081], pp. 35-6 (as S 2405); i, p. 582 (as Step Pyramid); CAIRO, CENTRE OF DOCUMENTATION photo. S.A., 2287; text, NEWBERRY MSS. ii. E.I. on 29; QUIBELL, *Saqqara (1912-1914)*, p. 39. (b) 'Ankhzefes  (woman), diorite, and (c) another, alabaster, see id. ib. pp. 38-9.



S 2427. SEḤOTPU , Overseer of the Nubian troops. Dyn. VI.

Wife, Nefertni .

South false-door, and inscribed slab and offering-basin. CAIRO, CENTRE OF DOCUMENTATION photos. S.A., 1928, 1931-2; see QUIBELL, *Saqqara (1912-1914)*, pp. 39-40.

S 2429. Dyn. II–III.

Id. ib. p. 40, with view, pl. xxiii [1].

Alabaster vessels of Iynikhnum , Royal chamberlain, Weḥat , etc. Id. ib. pl. xxiii [3, 4, cf. 2], pp. 9, 40.

S 2437. SEBKEMKHENT . Probably late Old Kingdom or 1st Int. Period.

Fragments of false-door. See id. ib. p. 40 [bottom].

S 2446. Dyn. I.

Fragment of vessel with text mentioning 1st *heb-sed* of 'Azab, schist, in Cairo Mus. JE 45170. Id. ib. pl. xxxiii [5], pp. 13, 41; LACAU and LAUER, *Pyr. à deg.* iv [1], pl. iii [4] (from QUIBELL), iv [2], p. 20; text, NEWBERRY MSS. ii. E.I. on 3.

S 2452. Old Kingdom.

Remains of female statue, and offering-basin of Nūfer, Royal acquaintance. See QUIBELL, *Saqqara (1912–1914)*, pp. 41–2.

S 2466. Old Kingdom.

Offering-basin of Mertmin , Royal acquaintance (woman), in Cairo Mus. JE 44147. See id. ib. p. 43.

S 2498. Probably temp. Ninūter or later.

Id. ib. pp. 44–6, with views, pls. xxiv, xxv, p. 10.

Four sealings, one of them probably of Ninūter. Text, id. ib. p. 45 [top].

S 3009. Dyn. III. See REISNER, *Tomb Development*, pp. 168 [3], 255 [44].

Two alabaster vessels of Iynikhnum , mentioning *heb-sed*. Texts, LACAU and LAUER, *Pyr. à deg.* v, figs. 10, 11, p. 5. See SMITH (W. S.) in REISNER, op. cit. p. 397.

S 3014.

Schist bowl of King Weneg. KAPLONY in *Ä.Z.* 88 (1963), Abb. 6 on p. 7, cf. pp. 8, 16 (from sketch by W. S. Smith).

S 3017. See REISNER, *Tomb Development*, pp. 165 [near bottom], 253 [28].

Stone jar-stand of Tety, Old Kingdom. See SMITH (W. S.) in ib. p. 397.

S 3035. ḤEMAKA , Boundary official, Treasurer of the King of Lower Egypt, etc. Temp. Den.

EMERY, *The Tomb of Hemaka* (hereafter EMERY); id. *Archaic Egypt*, pp. 75–6. Plan and sections, EMERY, pls. 1, 2; id. *Archaic Egypt*, figs. 38–9; plan, REISNER, *Tomb Development*, fig. 46 (by Firth), pp. 64–5. Views, EMERY, pls. 3–7; *I.L.N.* April 25, 1936, fig. on p. 722 [top left]; *Archiv aeg. Arch.* 1 (1938), Taf. i [upper]; LEIBOVITCH, *Anc. Eg.* fig. 162. Wooden palace-façade coffin, from subsidiary burial, found by Zaki Saad, *Archiv aeg. Arch.* 1 (1938), Taf. i [lower], p. 21.

Magazines.

C-F. Views, EMERY, pl. 10, pp. 10-11; of C, id. *Archaic Egypt*, pl. 20; *I.L.N.* April 25, 1936, fig. on p. 722 [middle right].

Jar-sealings of Den, Hemaka, and Ankhka, in Cairo Mus. EMERY, figs. 19-25, pp. 62-4.

Y. Views, id. ib. pl. 9 [D, E], p. 13.

Pottery vessels with names of contents, in Cairo Mus. Texts, SAAD in ib. pp. 51-2 [Nos. 1246-54] with fig. 16, cf. pl. 24 [upper].

Z. Views, EMERY, pl. 8, pp. 13-14.

Label with scenes and text of Zer, ebony, in Cairo Mus. JE 70114. Id. ib. pls. 17 [A], 18 [A], fig. 8, pp. 35-9 [No. 411] (as No. 408 on p. 13); GRDSELOFF in *Ann. Serv.* xlii (1943), fig. 17, p. 112-14; VIKENTIEV in *Bull. Inst. Ég.* xxxii (1949-50), pl. i [b], fig. 7, p. 189; GAMER-WALLERT, *Fische und Fischkulte im Alten Ägypten*, Taf. xiii [2] (as ivory), p. 118; MICHALOWSKI, *Art*, fig. 21 (as Zet, ivory, Abydos); top register, VIKENTIEV in *Ann. Serv.* liv (1957), pp. 295-8 with fig.; see *Descr. somm.* No. 6277B.

Two labels of Hemaka, ivory, in Cairo Mus. JE 70115-16. EMERY, pls. 17 [B, C], 18 [B, C], p. 39 [Nos. 412-13] (as Nos. 406-7 on p. 13); see *Descr. somm.* No. 6277A.

Box, wood inlaid with ivory, much damaged, containing disks (see below), in Cairo Mus. EMERY, fig. 11, p. 41 [No. 433] (as No. 423 on p. 14).

Gaming disks, originally in box (see above), in Cairo Mus. Id. ib. pls. 12-14, figs. 6, 7, pp. 28-32 [Nos. 306-50] (as Nos. 306-40 on p. 14). With hunting scene, steatite, JE 70164 (No. 307 of Emery, pl. 12 [B], frontispiece), and with two owls with outstretched wings, limestone, JE 70160 (No. 309 of Emery, pl. 12 [C, left]); *I.L.N.* April 25, 1936, figs. on p. 722 [bottom left]; DITTMANN in *Mitt. Kairo*, 6 (1936), Taf. 27 [a] (from *I.L.N.*), pp. 159-60; LEBOVITCH, *Anc. Eg.* figs. 144-5, p. 232; DE RACHEWILTZ, *L'Arte*, Tav. A, B; JE 70164, DRIOTON, *Le Musée Égyptien* (1939), pl. iii; id. and DU BOURGUET, *Pharaons*, pl. 6 [lower left]; ENGELBACH, *Introduction*, pl. i [1]; DONADONI, *Arte Egizia*, fig. 9; MÜLLER (H. W.), *Alt-Ägyptische Malerei*, Taf. 4 [a]; id. *Äg. Kunst*, Abb. 12 [lower]; id. in *Encyclopedia of World Art*, iv, pl. 335 [upper left]; DAUMAS, *Civ. de l'Ég.* pl. 23; LANGE and HIRMER, *Ägypten. Architektur* (1967), pl. i; EMERY, *Archaic Egypt*, pl. 46 [b]; MICHALOWSKI, *Art*, fig. 766; *Great Museums*, pl. 11; JE 70160, see KEIMER in *Annales de la Faculté de Lettres*, i (1951), pp. 82-3, cf. fig. 30 (from EMERY). With two cranes in clap-net, schist, JE 70165 (No. 310 of Emery, pl. 12 [C, right]); MÜLLER, *Äg. Kunst*, Abb. 12 [upper].

Sickle with names of Khasty (Den) and Hemaka, wood, in Cairo Mus. JE 70204. EMERY, pl. 15 [C], p. 33 [No. 393] (as No. 383 on p. 13); KAPLONY, *Inschriften, Suppl.* Taf. ix [1079], p. 35.

Fragment with painting of bull and monkey, limestone, in Cairo Mus. JE 70149. EMERY, pl. 19 [D], p. 40 [No. 431] (as No. 421 on p. 14); ENGELBACH, op. cit. pl. i [2].

AA. View, EMERY, pl. 9 [A], pp. 14-15.

Sealing of Den, on leather bag, in Cairo Mus. Id. ib. fig. 26, p. 64 [8], cf. pl. 9 [C], p. 41 [No. 434]; see BLACKMAN in *Studia Aegyptiaca*, i (1938), pp. 4-9 with fig.

Stone vessels.

Cup of Khasty (Den), crystal, fragment, in Cairo Mus. FIRTH in *Ann. Serv.* xxxi (1931), p. 47 with pl. [2]; EMERY, pl. 28 [bottom near left], pp. 1, 60 [No. 1717].

Three bowls, one of them of Khasty (Den), schist, in Cairo Mus. Texts, id. ib. fig. 18, p. 61 [Nos. 1719-21].

Bowl of Hēmakā, alabaster, possibly from here, in Michaelidis Colln. KAPLONY, *Inschriften*, *Suppl.* Taf. x [1080], p. 35.

Various.

Pot-mark with name of Semerkhet, on probably intrusive vessel. SAAD in EMERY, fig. 17, p. 54.

S 3036. Temp. Den.

EMERY, *Great Tombs*, i, pp. 71-81; plans and sections, pls. 14, 15, figs. 4, 4A, 35; REISNER, *Tomb Development*, fig. 47 (by Firth), p. 65; views, EMERY, op. cit. pls. 16, 17, 18 [B], of boat-grave, pl. 19 [A], p. 75.

Cylindrical jars, alabaster. Name of 'Aḥa in relief, (a) incomplete; FIRTH in *Ann. Serv.* xxxi (1931), p. 47 with pl. [1]; EMERY, op. cit. pl. 19 [B], fig. 38, pp. 75, 76 [No. 24]; (b) fragment; *serekh*, id. ib. fig. 39, p. 78 [No. 67]. With remains of text, id. ib. fig. 40, p. 78 [No. 68].

Jar-sealings of Den and 'Ankhka. Id. ib. fig. 37, p. 75.

S 3036X. IRISETHET , Companion of the house, Seal-bearer, etc. Dyn. III.

North-east of S 3036.

Niche-stela. KAPLONY, *Kleine Beiträge*, Taf. iv [833]; id. *Inschriften*, iii, Taf. 138 [833]; ii, p. 1194; i, pp. 232 [30], 429. See REISNER, *Tomb Development*, p. 296 [6]; SMITH, *Hist. Eg. Sculp.* pp. 142-3; id. in *Ä.Z.* 71 (1935), pp. 134 [5], 146.

S 3037 (or S 3038X). Dyn. III.

Niche-stela of Khuirēc . KAPLONY, *Inschriften*, iii, Taf. 139 [834] (sketch by W. S. Smith); ii, pp. 1194, 819 note 811; i, pp. 232 [31], 604; see REISNER, *Tomb Development*, p. 296 [11]; SMITH, *Hist. Eg. Sculp.* p. 143.

S 3038. Probably temp. 'Azab.

EMERY, *Great Tombs*, i, pp. 82-94; id. in *Ann. Serv.* xxxviii (1938), pp. 455-9; id. *Archaic Egypt*, pp. 82, 84. Plans, sections, etc., id. *Great Tombs*, i, pls. 21-6, figs. 6, 48-52A; id. in *Ann. Serv.* xxxviii (1938), pls. lxxviii-lxxxiii; id. *Archaic Egypt*, figs. 43-5. Views, id. *Great Tombs*, i, pls. 27-30 [A], 31-5; id. in *Ann. Serv.* xxxviii (1938), pls. lxxvi, lxxvii, lxxxiv, lxxxv; GALASSI, *Tehenu*, fig. 45; SMITH, *Art . . . Anc. Eg.* pl. 8; MICHAŁOWSKI, *Nie tylko piramidy . . .*, pl. 13; VANDERSLEYEN, *Das Alte Ägypten*, Abb. 6 [b].

Jar-sealings. Den, EMERY, *Great Tombs*, i, fig. 44, p. 82; 'Azab, fig. 45, p. 82; 'Ankhka, see p. 92.

Bag-sealings of Nebtka . One, in Toronto Mus. 969.137.8, NEEDLER in *Rotunda. The Bulletin of the Royal Ontario Museum*, 2 [4] (1969), fig. on p. 28 [top], cf. pp. 26-7. Another, EMERY, *Great Tombs*, i, pl. 30 [B], p. 82.

S 3073X.

Niche-stela of Tehenuka  (woman), Dyn. III. KAPLONY, *Kleine Beiträge*, Taf. iii [835]; id. *Inschriften*, iii, Taf. 139 [835]; ii, p. 1194; i, pp. 232 [32], 662; see REISNER,

Tomb Development, pp. 296 [5], 397; SMITH, *Hist. Eg. Sculp.* pp. 141, 143, 248; id. in *A.Z.* 71 (1935), pp. 134 [6], 145 [bottom].

S 3078. End of Dyn. III or early Dyn. IV.

See FIRTH in *Ann. Serv.* xxxi (1931), p. 48; REISNER, *Tomb Development*, pp. 169 [10], 204-5 [8], 261 [16], 266 [14], 280 [27], 364. Plan of chapel, JACQUET-GORDON, *Domaines*, fig. 117 (by W. S. Smith).

Right thickness of passage, remains of offering-bringers. SMITH, *Hist. Eg. Sculp.* pl. 34 [c], p. 151 with note 1; cf. id. *Art . . . Anc. Eg.* pl. 27 [B], p. 41.

Estates on side walls of chapel and thicknesses of niche. Names, JACQUET-GORDON, op. cit. pp. 331-2 [5S4] (copied by W. S. Smith), cf. figs. 117-18. One block in Boston Mus. 63.489, SMITH (W. S.) in *88th Annual Report 1963*, fig. on p. 58 [upper], cf. p. 61.

S 3080. Dyn. IV.

Marsh-scene with hippopotami, papyrus-harvest, men carrying various articles, and cooking, all in passage with painted decoration. Man with cages and three others, SMITH, *Hist. Eg. Sculp.* pl. 51 [a], p. 174; sleeping man and two cooks, figs. 181 [right], 182 [a], pp. 174, 315-16.

S 3111. Temp. Den or 'Azab.

EMERY, *Great Tombs*, i, pp. 95-106; id. in *I.L.N.* Feb. 27, 1937, pp. 348-9 with figs.; *Chron. d'Ég.* xii (1937), pp. 163-5. Plan and section, EMERY, *Great Tombs*, i, pl. 36, figs. 56, cf. 56A; views, pls. 37-42.



Jar-sealings of Den, 'Azab, and Sabu , Boundary official. Name and title of Sabu, id. ib. fig. 55, pp. 95, 98, 99.

S 3120. Temp. K̄a'a.

EMERY, *Great Tombs*, i, pp. 121-4; plan and section, pl. 53, fig. 67A; views, pl. 54. Jar-sealings of K̄a'a. One, id. ib. fig. 67B.

S 3121. Temp. K̄a'a.

EMERY, *Great Tombs*, i, pp. 116-20; plan and section, pl. 48, fig. 67; views, pl. 49. Remains of painted decoration from corridors; id. ib. pls. 50-2, p. 116. Fragments of jar-sealings of K̄a'a. See id. ib. p. 119.

S 3302. SHEPSI , Prophet of Horus *kms-c*, Overseer of the scribes of the land of  nome, etc. Probably late Dyn. IV.

False-door, in Cairo Mus. JE 68923. Text of lintel, GARDINER Notebook, 127, p. 51 verso [middle]. See SMITH, *Hist. Eg. Sculp.* p. 150 note 2; *Descr. somm.* No. 6283.

S 3357. Temp. 'Aḥa.

EMERY, *Hor-Aḥa* (hereafter EMERY); id. *Archaic Egypt*, pp. 54, 56; id. in *I.L.N.* Feb. 12, 1938, pp. 247-51; *Archiv aeg. Arch.* 1 (1938), pp. 50-2; *Chron. d'Ég.* xiii (1938), pp. 283-5. Plan and section, EMERY, pls. 1, 2; id. *Archaic Egypt*, figs. 15-16; id. in *I.L.N.*

Feb. 12, 1938, fig. 1 on p. 247; plan, LAUER in *Mitt. Kairo*, 15 (1957), Taf. xix [2], pp. 154-5. Views, EMERY, pls. 4-7; id. in *I.L.N.* Feb. 12, 1938, figs. 3, 5 on p. 248.

Sealings of 'Aḥa. EMERY, pls. 9-11, figs. 13-37, pp. 19-33; id. in *I.L.N.* Feb. 12, 1938, fig. 2 on p. 247.

Pottery vessels with texts giving contents and name of 'Aḥa. Some, SAAD in EMERY, pl. 16 [A]; texts, pls. 20-4, pp. 74-6; two jars, id. in *I.L.N.* Feb. 12, 1938, fig. 7 on p. 249; another two, ZAKY and ISKANDER in *Ann. Serv.* xli (1942), fig. 52, pp. 295, 313.

Model estate. EMERY, *Great Tombs*, ii, p. 171; plans, sections, and reconstructions, pls. lx, lxvi; views, pls. lvii-lix; id. *Archaic Egypt*, pl. 19; reconstruction, fig. 17.

Boat-grave. Plan and sections, EMERY, pl. 3. Views, id. ib. pl. 8; id. *Great Tombs*, ii, pl. lvii [upper]; id. *Archaic Egypt*, pl. 18; id. in *I.L.N.* Feb. 12, 1938, fig. 4 on p. 249.

S 3471. Temp. Zer.

EMERY, *Great Tombs*, i (hereafter EMERY, i), pp. 13-70; id. *Archaic Egypt*, p. 63; id. in *Ann. Serv.* xxxix (1939), pp. 427-37. Plan and section, EMERY, i, pl. 2, figs. 2, 10; id. *Archaic Egypt*, fig. 27. View, EMERY, i, pl. 3; id. in *Ann. Serv.* xxxix (1939), pl. lxii [A].

Jar-sealings of Zer. View of jars, EMERY, i, pl. 7 [B], p. 18; id. in *Ann. Serv.* xxxix (1939), pl. lxii [B], p. 437.

Palette, slate, re-used as trial-piece, King smiting captive. EMERY, i, fig. 31, p. 60 [565]; id. *Archaic Egypt*, fig. 23.

Copper implements, vessels, and plates, stone vessels and palettes, remains of furniture, etc., in Cairo Mus. EMERY, i, pls. 4-7 [A], 8-13, figs. 13-30, 32-3, pp. 20-70; id. in *Ann. Serv.* xxxix (1939), pls. lxiii-lxv, figs. 24-35, pp. 429-36; id. *Archaic Egypt*, pls. 41, 42 [a], 43-45 [a].

S 3477.

Niche-stela of a King's daughter, Dyn. II, found nearby. SMITH, *Art . . . Anc. Eg.* pl. 14, pp. 27-8; EMERY, *Archaic Egypt*, pl. 32 [a]; id. *A Funerary Repast* [etc.], pl. 3 [A], p. 2; VANDERSLEYEN, *Das Alte Ägypten*, Abb. 239. Deceased at table, BAKER, *Furniture*, fig. 20, p. 31. See KAPLONY, *Inschriften*, i, pp. 233 [35], 646-7; id. *Kleine Beiträge*, p. 104 [Sp. 35].

S 3500. Temp. Ḳa'a.

EMERY, *Great Tombs*, iii, pp. 98-109. Plan, sections, and reconstruction, id. ib. pls. 114-15; of subsidiary burial, pl. 116. Views, id. ib. pls. 117-22; GIEDION, *The Eternal Present*, ii, fig. 150.

Five types of sealings, some of Ḳa'a. EMERY, op. cit. pl. 124 [lower, 1-5], pp. 103, 109.

S 3503. Temp. Merytneit.

EMERY, *Great Tombs*, ii (hereafter EMERY, ii), pp. 128-70; id. *Archaic Egypt*, pp. 66-8. Plan, section, reconstructions, EMERY, ii, pls. xxxviii, xxxix, xlvi, figs. 201-2. Plan and section, id. *Archaic Egypt*, fig. 30; of subsidiary burials, EMERY, ii, figs. 207-21. Reconstruction, LAUER in *Comptes rendus* (1956), pl. i [2], p. 372; id. in *B.I.F.A.O.* lv (1955), pl. iv [B], p. 156; id. in *Mitt. Kairo*, 15 (1957), Taf. xviii [2], p. 154. Views, including finds and subsidiary burials, EMERY, ii, pls. xl-xliv [a], xlvii-liii; id. *Archaic Egypt*, pl. 5; GIEDION, *The Eternal Present*, ii, fig. 151.

Jar-sealings, some of Zer. EMERY, ii, pls. liv-lvi, figs. 225-32, pp. 168-70.

Burial chamber [L of Emery]. Id. ib. pp. 140-2; plan, fig. 204.

Stone vessels of Merytneit. Texts, id. ib. figs. 205-6, p. 141.

Boat-grave.

Id. ib. p. 138; plan and section, fig. 203; views, pls. xlv [b], xlv.

S 3504. Temp. Zet.

EMERY, *Great Tombs*, ii (hereafter EMERY, ii), pp. 5-127; id. *Archaic Egypt*, pp. 71, 73; id. in *I.L.N.* May 23, 1953, figs. 1-28, pp. 839-43. Plans, sections, and reconstruction, EMERY, ii, pls. i-v; plan, id. in *Archaeology*, 8 (1955), fig. on p. 2; LECLANT in *Orientalia*, N.S. 23 (1954), pl. xiii [8] (from EMERY), pp. 70-1; plan and section, EMERY, *Archaic Egypt*, figs. 34-5. Views, including subsidiary burials and finds, EMERY, ii, pls. viii-xxxiv; id. in *Archaeology*, 8 (1955), figs. on pp. 3, 5, 6 [middle and lower]; id. in *La Revue du Caire*, xxxiii, No. 175 (1955), fig. 16; of subsidiary burials, LAUER in *B.I.F.A.O.* lv (1955), pls. ii, iii [1], pp. 156-8, 166; of burial chamber, id. in *Mitt. Kairo*, 15 (1957), Taf. xix [3], p. 155. Detail of palace-façade decoration, id. ib. Taf. xvii [3], p. 153 note 3.

Bench with clay bull's heads, EMERY, ii, pls. vi, vii, p. 7; id. *Archaic Egypt*, pls. 8, 9; id. in *La Revue du Caire*, xxxiii, No. 175 (1955), fig. 17; id. in *Archaeology*, 8 (1955), figs. on p. 4, cf. p. 7; LECLANT, op. cit. pl. xiv [10], p. 70; LAUER in *Bull. Soc. fr. d'Ég.* No. 15 (Feb. 1954), figs. 2, 3, pp. 15-18; id. *Saqqara*, pl. 75; VIKENTIEV in *Bull. Inst. Ég.* xxxvi (1953-4), pl. i [A], pp. 298-9; EDWARDS, *Pyramids* (1961), pl. 1 [a]; MENDELSSOHN, *The Riddle of the Pyramids*, pl. 6; VANDERSLEYEN, *Das Alte Ägypten*, Abb. 2 [c].

Labels.

With names of Zet and Sekhemka-sez , ivory. EMERY, ii, pl. xxxv [b], fig. 105, pp. 16-17, 102-3 [1]; LECLANT in *Orientalia*, N.S. 23 (1954), pl. xiii [9], p. 71 [top]; VIKENTIEV in *Bull. Inst. Ég.* xxxvi (1953-4), pl. i [B], figs. 1, 7, 11, pp. 293-310; id. in *Ann. Serv.* lvi (1959), pl. ii, fig. 2, pp. 4, 30.

Another, similar to last, ivory, presumably from here, in Kofler-Truniger Colln. VIKENTIEV in *Ann. Serv.* lvi (1959), pls. i, iii, fig. 1, pp. 4-16, 29-30; MÜLLER (H. W.), *Ägyptische Kunstwerke, Kleinfunde und Glas in der Sammlung E. und M. Kofler-Truniger, Luzern*, pl. A79, pp. 50-1.

With texts carved or in ink, giving contents, many of Sekhemka-sez, wood. EMERY, ii, figs. 107-22, 124-5, pp. 104-7 [B. 1-16, 18, 19]; one, VIKENTIEV in *Ann. Serv.* lv (1958), fig. 1, pp. 25-33.

With text with name of Kāca, wood. EMERY, ii, fig. 123, pp. 23, 107 [17].

Other finds.

Wand of Zet and Sekhemka-sez, ivory, fragment. Id. ib. pl. xxxv [a], fig. 106, pp. 20 [394], 104 [2].

Set of twenty-six gaming-pieces (ten inscribed), ivory, with gaming-board, wood and ivory. Id. ib. pl. xxix [top left], pp. 59 [371-2], 104 [3]; id. in *Archaeology*, 8 (1955), fig. on p. 6 [upper].

Sealings of Zet, Den, Kāca, and Sekhemka-sez. EMERY, ii, pls. xxxvi, xxxvii, figs. 143-200, pp. 114-27, cf. 14-24.



Inscribed stone and pottery vessels. Texts, id. ib. figs. 126-42, pp. 108-14.

S 3505. Temp. Kaca.

EMERY, *Great Tombs*, iii (hereafter EMERY, iii), pp. 5–36; id. *Archaic Egypt*, pp. 88, 90; id. in *I.L.N.* May 15, 1954, pp. 803–5. Plans and sections, EMERY, iii, pls. 2–4; id. *Archaic Egypt*, fig. 53; plan, id. in *I.L.N.* May 15, 1954, fig. 1 on p. 803; id. in *La Revue du Caire*, xxxiii, No. 175 (1955), fig. on p. 14; id. in *Archaeology*, 8 (1955), fig. on p. 8 [upper]; LECLANT in *Orientalia*, n.s. 24 (1955), pl. xxxi [22] (by Emery), pp. 307–8; LAUER in *Bull. Soc. fr. d'Ég.* No. 18 (July 1955), fig. 3 (by Emery), pp. 37–9; id. in *Mitt. Kairo*, 15 (1957), Taf. xvii [2], pp. 152–3, 162, 164. Views, EMERY, iii, pls. 9–22, 26; id. in *I.L.N.* May 15, 1954, figs. 3, 4, 6–12 on pp. 804–5; id. in *La Revue du Caire*, xxxiii, No. 175 (1955), figs. 18–19; id. *Archaic Egypt*, pl. 7; id. in *Archaeology*, 8 (1955), figs. on pp. 8 [lower], 9, cf. p. 7; LECLANT, op. cit. pls. xxx [21], xxxii [23–4], xxxiii [25], pp. 307–8; VANDERSLEYEN, *Das Alte Ägypten*, Abb. 7 [b]; LAUER, *Saqqara*, pl. 76. Patterns of decoration, EMERY, iii, pls. 6–8.

Fragments of stone vessels. King Sneferka, schist; id. ib. pls. 28 [a], 38 [1], pp. 31–2 [B. 1]. Mery, three fragments, schist; id. ib. pl. 38 [7, 35, 43], p. 32. Titles; id. ib. pl. 38 [6, 8, 31, 59], p. 32.

Fragments of pottery vessels with texts in ink. Titles, id. ib. pl. 38, p. 32 [C].

Sealings, some of Kaca, Merka, Nefermerib , Kherepka, Setka , etc. Id. ib. pls. 37–8, 28 [c–h], pp. 32–6 [D].

Chapel on north side. Views, id. ib. pls. 24–5.

Remains of bases with feet of two male statues, wood. Id. ib. pl. 27, p. 13; id. in *I.L.N.* May 15, 1954, fig. 5 on p. 804; id. *Archaic Egypt*, pl. 27.

Subsidiary tomb against east face. Reconstruction, EMERY, iii, pl. 5.

Niche-stela of Merka , Count, *sma* and *sem*-priest, Prophet of Neith, etc., end of Dyn. I or later. Id. ib. pls. 23, 39, pp. 30–1; id. in *I.L.N.* May 15, 1954, fig. 2 on p. 803; id. *Archaic Egypt*, pl. 30 [a]; LECLANT, op. cit. pl. xxxiv [26], p. 308.

S 3506. Temp. Den.

EMERY, *Great Tombs*, iii (hereafter EMERY, iii), pp. 37–72; id. in *I.L.N.* March 19, 1955, pp. 500–3. Plan, sections, and reconstructions, EMERY, iii, pls. 40–3; plan, id. in *I.L.N.* March 19, 1955, fig. 1 [left] on p. 500. Views, id. ib. figs. 6–17 on pp. 502–3; EMERY, iii, pls. 50–65; id. *Archaic Egypt*, pls. 6, 17, 21; LAUER in *B.I.F.A.O.* lv (1955), pl. iii [2, 3], p. 156; id. in *Comptes rendus* (1956), pl. i [1], p. 372; GIEDION, *The Eternal Present*, ii, figs. 153, 155; VANDERSLEYEN, *Das Alte Ägypten*, Abb. 5, 6 [a].

Titles on lintel of doorway to burial chamber; EMERY, iii, pl. 83 [1], p. 60 [A].

One alabaster and one pottery vase with texts in ink giving contents. Texts, id. ib. pl. 83 [2, 3], p. 60 [B].

Fragments of schist vessels with titles and names. One, in Brit. Mus. 68229; text, id. ib. pl. 83 [10], p. 61; MARTIN, *Hetepka*, No. 2. Texts of two of Waznes , Greatest of the seers, EMERY, iii, pl. 83 [13, 14]; of others, pl. 83 [4–9, 10–12], pp. 60–1.

Sealings, altogether 186, of Zer, Den, Hemaka, Ankhka, Mezedka, Setka, and Kani . Id. ib. pls. 69, 78–82, pp. 61–72 [D].

Boat-grave.

Plan and sections, id. ib. pls. 40 [right], 44, pp. 42, 49; plan, id. in *I.L.N.* March 19, 1955, fig. 1 [right] on p. 500. Views, id. ib. figs. 2–5 on pp. 500–1; EMERY, iii, pls. 66–8.

S 3507. Temp. Den.

EMERY, *Great Tombs*, iii (hereafter EMERY, iii), pp. 73-97; id. in *I.L.N.* June 2, 1956, pp. 646-8; id. in *J.E.A.* 42 (1956), pp. 1-2. Plan, section, and reconstruction, EMERY, iii, pls. 85-6; id. in *I.L.N.* June 2, 1956, figs. 1, 2 on p. 646; KLASSENS in *Phoenix*, ii (1956), figs. 42, 48 (by Emery), pp. 71-8; views, EMERY, iii, pls. 87-96 [a]; id. in *I.L.N.* June 2, 1956, figs. 3, 4, 6 on p. 647, cf. figs. 7-11 on p. 648 (finds); id. *Archaic Egypt*, pl. 4; KLASSENS, op. cit. fig. 43, pp. 72-3, 76; NEEDLER in *Rotunda. The Bulletin of the Royal Ontario Museum*, 2 [4] (1969), fig. on p. 26; *Exhibition of Recent Discoveries in Egypt and the Sudan by the Egypt Exploration Society*. Brit. Mus. 16th Oct.-30th Nov. 1968, fig. on p. 10; VANDER-SLEYEN, *Das Alte Ägypten*, Abb. 7 [a].

Block, two figures of a King before baboon, Dyn. I, re-used, in Brit. Mus. 67153. EMERY, iii, pls. 97-8, p. 84 [1]; see *Brit. Mus. Quarterly*, xxxiv (1969-70), p. 186.

Lintel with lions, fragment, from roofing of burial chamber. EMERY, iii, pl. 96 [b], p. 84 [2]; id. in *I.L.N.* June 2, 1956, fig. 5 on p. 647; id. *Archaic Egypt*, pl. 32 [b]; KLASSENS, op. cit. fig. 44, p. 76.

Plaque, inscribed, ivory. EMERY, iii, pls. 102 [65], 107 [1], pp. 84 [65], 93 [A.18].



Toilet-vase with Queen's title, ivory. Id. ib. pls. 102 [72], 107 [2], pp. 83 [72], 93 [A.19].



Stone vessels with texts, fragments. Id. ib. pls. 105 [a], 107 [3-11], pp. 94-5 [B].



Pottery vessels with texts, fragments, some of Den. Id. ib. pls. 105 [b], 107 [12-23], p. 95 [C].





Sealings of Den, K̄a'a, and Sekhka . Id. ib. pls. 105 [c, d], 106, pp. 95-7 [D].

S 3508. Offering-basins, late Old Kingdom.

Seḥy   , Supervisor of magazines(?), etc., in Brit. Mus. 68231. MARTIN, *Ḥetepka*, No. 71.

Dedicated by father Thethi  , Inspector of magazines(?), etc. Id. ib. No. 72.



Nebishet   , Overseer of the store-room of the King's repast, in Oxford, Ashmolean Mus. 1969.477. Id. ib. No. 73.

S 3509. ḤETEPKA   or TEPKA  , Inspector of hairdressers of the Great House, Prophet of Saḥurēc and of the Pyramid of Neferirkarē, etc. Late Dyn. V or Dyn. VI.

Plan XLVII.

MARTIN, *Ḥetepka*; EMERY in *J.E.A.* 51 (1965), p. 4 [bottom]; LAUER in *Bull. Soc. fr. d'Ég.* No. 43 (July 1965), p. 21 [middle].

I. Vestibule.

(1) Doorway. (a) Deceased and eldest son Irenptaḥ   , with man censuring and attendant. (b) Bottom of similar scene. (c) Registers, I, butchers, II, statue dragged on sledge, with son Irenptaḥ. (d) Remains of bottom register, two men bringing bull.

(c) EMERY, op. cit. pl. iv [3]; id. in *I.L.N.* March 6, 1965, fig. 5 on p. 21.

(2) Two bottom registers of offering-bringers. (3) Remains of deceased, with three registers of attendants and dog behind him.

II. Corridor.

(4) Harvest scenes watched by deceased and son, including reaping corn, binding sheaves, and donkeys threshing. (5) Men bringing cattle and ibex. (6) Scribes and a man bringing

[cattle]. (7) Remains of butchers and fowl. (8) Remains of bottom register with offering-bringers.

III. Offering-room.

(9) and (10) Remains of two registers, butchers and offering-bringers.

(11) Remains of two bottom registers, offering-bringers and cooking. (12) Remains of bottom register with two groups of butchers. (13) Remains of deceased at table, and offering-bringers and butchers. (14) False-door (top lost).

(11)–(14) Id. in *J.E.A.* 51 (1965), on pl. iv [4]; id. in *I.L.N.* March 6, 1965, on fig. 6 on p. 22.

S 3510. Offering-basins, late Old Kingdom.

Two, Kanebef (or Kasinebef) $\overline{\text{𓂏}} \overline{\text{𓂏}}$, Overseer of the six and ten of the boat, Inspector of the boat, etc. MARTIN, *Hetepka*, Nos. 74–5.

Watnefert $\overline{\text{𓂏}} \overline{\text{𓂏}} \overline{\text{𓂏}} \overline{\text{𓂏}}$ (woman), in Cambridge, Fitzwilliam Mus. E.2. 1969. Id. ib. No. 76.

S 3511. KAIḤAP $\overline{\text{𓂏}} \overline{\text{𓂏}} \overline{\text{𓂏}}$, Inspector of $\overline{\text{𓂏}} \overline{\text{𓂏}}$, etc. Dyn. V.

Wife, Mertmin $\overline{\text{𓂏}}$, Prophetess of Ḥathor Mistress of the Sycamore.

False-door, in Brit. Mus. 1848. MARTIN, *Hetepka*, No. 14.

S 3513. ITISEN $\overline{\text{𓂏}} \overline{\text{𓂏}}$, Judge and Boundary official, *iun-kenmut* priest, etc. Dyn. V.

Offering-table, much effaced. MARTIN, *Hetepka*, No. 16.

Wooden statue, inscribed. Id. ib. No. 15.

S 3514.

Offering-basin of Khertnef $\overline{\text{𓂏}} \overline{\text{𓂏}}$, late Old Kingdom. Id. ib. No. 82.

S 3518.¹ Dyn. III.

EMERY in *J.E.A.* 56 (1970), p. 10; plan and sections, pls. xix, xx.

Jar-sealing of Neterikhet, in Cairo Mus. JE 91311. Id. ib. pl. xvii [1]; MARTIN, *Hetepka*, No. 5.

OLD KINGDOM TOMBS NOS. 1–88 OF MARIETTE

Maps XLV, XLVI

No. 1 [B 5]. RUZI $\overline{\text{𓂏}} \overline{\text{𓂏}}$, Inspector of treasurers of the temple. Probably Dyn. V.

MARIETTE, *Mastabas*, p. 96, with plan of chapel.

False-door. Name and titles, id. ib. p. 96.

¹ There are two tombs of this number. Position of the other (more correctly S 3516), EMERY in *J.E.A.* 55 (1969), on fig. 1 on p. 32.

No. 2 [B 10]. IFEFI  FEFI, Overseer of the royal granary, *warb*-priest the Pyramid of Userkaf, Prophet of Rēc in the Sun-temple of Userkaf, etc. Dyn. V or later.

Wife, Ḥemnefert  , Royal acquaintance.

MARIETTE, *Mastabas*, pp. 99-101, with plan of chapel.

False-door. Names and titles, id. ib. p. 100.

Offering-basin, in Cairo Mus. CG 1359. Text, BORCHARDT, *Denkmäler*, i, p. 27. See

MARIETTE, op. cit. p. 101 [2].

Statue, wood, in Cairo Mus. See id. ib. pp. 99, 100-1 [d, 1], with detail of collar.

No. 3 [B 6]. SETHU [I]  , Inspector of treasurers of the Temple. Probably Dyn. V.

Drum of doorway. Name and title, MARIETTE, *Mastabas*, p. 97.





False-door. Fragments of jambs, in Copenhagen, Ny Carlsberg Glypt. Æ.I.N.6, 7; SCHMIDT, *Choix* (1910), pl. ii [2], p. 12; id. *Den Æg. Sam.* (1908), pp. 53-4 [E.10, 11] with fig.; id. *Levende og Døde*, fig. 121; MOGENSEN, *Coll. ég.* pl. xcii [A 660-1], p. 88; KOEFOED-PETERSEN, *Cat. des bas-reliefs*, pl. xxi [14], pp. 22, 71; texts, id. *Rec. inscr.* p. 30 [6, 7].

No. 4 [B 11]. KHNEMHOTP  , King's *warb*-priest of the Great House, Dancer. Probably Dyn. V or later.

Mother, Nubhotp  , Royal acquaintance.

MARIETTE, *Mastabas*, p. 102, with plan of chapel.

Offering-table, in Cairo Mus. CG 1306. Id. ib. fig. on p. 435 [b]; BORCHARDT, *Denkmäler*, i, Bl. 2, p. 5. Names, LIEBLEIN, *Dict.* No. 1725.

No. 5 [A 2; S 3073]. KHAḤBAUSOKAR  HETHES  , Overseer (*mdh*) of Anubis foremost of the Sacred Land, Prophet of Seshet, etc., and wife NEFERHÖTER-ḤATHOR  TEPES  , Royal acquaintance. Middle Dyn. III to early Dyn. IV.

MARIETTE, *Mastabas*, pp. 71-9, with plans on p. 71; REISNER, *Tomb Development*, pp. 169 [6], 203 [3], 261 [12], 267-9 [2], 280 [34], with plans, figs. 158-63.

South chapel. KhaḤbausokar.

Thicknesses of doorway, painted offering-list, much damaged.

Niche, lintel, and drum with names and titles, back panel, deceased at table with offering-list below, thicknesses, standing with offering-list below, in Cairo Mus. CG 1385. BORCHARDT, *Denkmäler*, i, Bl. 10, pp. 44-7; MARIETTE, op. cit. figs. on pp. 74-5 [upper], 77-9; MURRAY, *Saqqara Mastabas*, i, pls. i, ii [top], p. 3; MASPERO, *Guide du Visiteur au Musée de Boulaq* (1883), pl. facing p. 31; VANDIER, *Manuel*, ii, fig. 272 [upper right], p. 392; TERRACE and FISCHER, *Treasures*, pp. 37-40 with pls. Deceased on panel, MÜLLER, *Äg. Kunst*, Abb. 18; upper part, ENGELBACH, *Introduction*, fig. 32; offering-list, see HASSAN, *Giza*, v, pp. 97-103 with fig. 16; linen-list, BRUGSCH, *Thes.* 1410-11. Deceased and titles on left thickness, SMITH, *Hist. Eg. Sculpt.* pl. 36 [a], pp. 149-50; deceased, STAEBELIN, *Tracht*, Taf. ix [14]; upper part, MURRAY, op. cit. ii, pl. i, pp. 1-2 [2]. Animal as determinative of name, KEIMER in *Mitt. Kairo*, 8 (1939), Taf. 17 [d], p. 40. Titles, SETHE in MURRAY, op. cit. ii, pp. 11-12 [13]. See MASPERO, *Guide*, p. 32 [63].

Lintel with name and titles, in Cairo Mus. JE 42002. WEILL in *Sphinx*, xv (1911-12), fig. on p. 2, cf. pp. 1-4.

North chapel.

Wife Neferhôtep-hathor.

Niche (upper part lost), back panel, wife at table with offering-list below, in Cairo Mus., thicknesses, standing with short offering-list below, in Cairo Mus. CG 1386 (left), 1387 (right). MURRAY, *Saqqara Mastabas*, i, pl. ii [without top], pp. 2-4; see MASPERO, *Guide*, p. 32 [64]. Thicknesses, BORCHARDT, *Denkmäler*, i, Bl. 11, p. 48; MARIETTE, *Mastabas*, figs. on pp. 75 [lower], 76. Wife on CG 1387 and head on CG 1386, VON BISSING, *Äg. Kunstgeschichte*, Taf. lxxix [413a, b], *Text*, i, pp. 42, 98; head on CG 1386, id. *Denkmäler*, Text to Taf. 5 [2nd fig.]. Upper part of wife on CG 1387, FECHHEIMER, *Plastik* (1914), Taf. 103; (1929), Taf. 113; head, CAPART, *L'Art ég.* (1911), pl. 124; id. *Documents*, i, pl. 14.

Lintels of wife. (a) Cairo Mus. CG 57129 (probably); see REISNER, *Tomb Development*, p. 203 [bottom, b]. (b) Fragment; MARTIN, *Hetepka*, No. 8.

Drums of wife. (a) Cairo Mus. CG 1737; text, BORCHARDT, *Denkmäler*, ii, p. 164; see REISNER, op. cit. p. 203 [bottom, a]. (b) MARTIN, *Hetepka*, No. 6.

Block with name of wife, see REISNER, op. cit. p. 203 [bottom].

No. 6 [C 15]. TṢ = $\text{𓏏} \text{𓏏}$, *warb*-priest of Rē^c in the Sun-temple of Saḥurē^c, Overseer of the fields and fowl-yard, etc. Temp. Saḥurē^c or later.

Wife, Semertmin = $\text{𓏏} \text{𓏏}$, Prophetess of Hathor and Neith North of the Wall, etc.

Usurped by woman ḤEM(T)RĒ^c = $\text{𓏏} \text{𓏏}$, Overseer of female singers, Overseer of ladies of the harīm, etc. Late Dyn. V or Dyn. VI.

MARIETTE, *Mastabas*, pp. 137-42, with plan of chapel.

Doorway. Jambs, left, Ḥem(t)rē^c with scribes watching registers of offering-bringers, bringing animals, and boat-scene, right, similar, deceased with daughter. Thicknesses, Ḥem(t)rē^c (superimposed on figure of Ty). Texts, id. ib. pp. 138-9; some blocks probably in Cairo Mus., see SMITH (W. S.) in REISNER, *Tomb Development*, p. 398.

False-door of Ty usurped by Ḥem(t)rē^c, in Cairo Mus. CG 1380. BORCHARDT, *Denkmäler*, i, Bl. 9, pp. 37-41; texts, MARIETTE, op. cit. pp. 140-2; offering-list, HASSAN, *Giza*, vi [2], pls. xli-xlvi [53], p. 127; see MASPERO, *Guide*, p. 32 [66].

Double-statue, headless, Ty, and wife seated, in Cairo Mus. CG 95. BORCHARDT, *Statuen*, i, Bl. 21, p. 75; WEIGALL, *Anc. Eg. . . . Art*, 53 [lower right]; HORNEMANN, *Types*, v, pl. 1176.

No. 7 [C 13]. ITI $\text{𓏏} \text{𓏏}$, Overseer of scribes of the land in the Two Houses, Prophet of Horus *km̄s-r*,¹ etc. Dyn. V.

Drum of doorway. Text, MARIETTE, *Mastabas*, p. 135.

Statue of deceased seated, in Cairo Mus. CG 26. BORCHARDT, *Statuen*, i, Bl. 7, p. 27; FECHHEIMER, *Plastik*, Taf. 30; upper part, PETRIE Giza photos. 531-2.

¹ On statue.

No. 8 [C 2]. HETEP $\frac{\text{H}}{\text{A}}\frac{\text{E}}{\text{P}}$, Overseer of the scribes of the land in the Two Houses of Upper and Lower Egypt, Director of scribes of petitions, etc. Middle Dyn. V or later.

MARIETTE, *Mastabas*, pp. 114-15, with plan of east face.

Texts of unfinished false-door, id. ib. p. 115.

No. 9 [B 4]. IPI $\text{I} \square \text{P}$, Greatest of the physicians of Lower Egypt, Prophet of Horus of Shenwet(?), and of Heka, etc. Middle Dyn. V or later.

MARIETTE, *Mastabas*, pp. 95-6, with plan of chapel.

Thicknesses, deceased and titles, in Ungar Collection. FISCHER in *Metropolitan Museum Journal*, 10 (1975), fig. 12-14, p. 16 with note 48; titles, MARIETTE, op. cit. p. 96.

No. 10 [C 14]. ANKHI $\text{A} \text{N} \text{K} \text{H} \text{I}$, Overseer of sculptors, etc. Probably Dyn. V.

MARIETTE, *Mastabas*, p. 136, with plan of chapel.

False-door. Panel, in Cairo Mus. CG 1729; BORCHARDT, *Denkmäler*, ii, Bl. 94, p. 159; texts, MARIETTE, op. cit. p. 136.

No. 11 [B 13]. SENEZEMIB $\text{S} \text{E} \text{N} \text{E} \text{Z} \text{E} \text{M} \text{I} \text{B}$ BEBIB $\text{B} \text{E} \text{B} \text{I} \text{B}$, Chief of the Great Estate, Judge and Master of the largesse, Overseer of works, etc. Probably middle Dyn. V.

Wife, Bebi $\text{B} \text{E} \text{B} \text{I}$, Royal acquaintance.

MARIETTE, *Mastabas*, pp. 104-6, with plan of chapel.

False-door (panel and right thickness in Cairo Mus. CG 1668, 1628). Texts, id. ib. p. 105. CG 1668 and 1628, see BORCHARDT, *Denkmäler*, ii, pp. 125-6, 98 (texts).

Statue-group, deceased and wife with [small son], in Cairo Mus. CG 151. Id. *Statuen*, i, Bl. 34, p. 110; SHOUKRY, *Privatgrabstatue*, Abb. 31; HORNEMANN, *Types*, v, pl. 1405. Texts, MARIETTE, op. cit. p. 106. See MASPERO, *Guide*, p. 67 [145].

No. 12 [B 12]. NEFERHÖTEP $\text{N} \text{E} \text{F} \text{E} \text{R} \text{H} \text{Ö} \text{T} \text{E} \text{P}$, Overseer of the scribes of the land, etc. Probably Dyn. V.

Wife, Thenteti $\text{T} \text{H} \text{E} \text{N} \text{T} \text{E} \text{T} \text{I}$, Prophetess of Hathor, etc.

MARIETTE, *Mastabas*, pp. 103-4, with plan of chapel.

Stela, deceased with son Neferherenptah, in Cairo Mus. CG 1528. BORCHARDT, *Denkmäler*, i, Bl. 46, pp. 227-8; KIELLAND, *Geometry in Egyptian Art*, fig. 54 on p. 187. See MARIETTE, op. cit. p. 103.

Double-statue of deceased and wife, in Cairo Mus. CG 89. BORCHARDT, *Statuen*, i, Bl. 20, pp. 70-1; PERROT and CHIPIEZ, *Hist. de l'Art*, i, fig. 443; MASPERO, *Égypte*, fig. 125; MEIER-GRAEFE, *Pyramide und Tempel*, Taf. 14; SHOUKRY, *Privatgrabstatue*, Abb. 18; DRIOTON and SVED, *Art ég.* fig. 24; FETT, *Mumier og sfinks*, pl. on p. 91; HORNEMANN, *Types*, v, pl. 1145. Texts, MARIETTE, op. cit. p. 104.

No. 13 [D 44]. NEMTINŪFER $\text{N} \text{E} \text{M} \text{T} \text{I} \text{N} \text{Ū} \text{F} \text{E} \text{R}$, Inspector of oils of King's adorners of the Great House, Adorner of Horus, etc. Dyn. V or later.

Wife, Hathorshepses $\text{H} \text{A} \text{T} \text{H} \text{O} \text{R} \text{S} \text{H} \text{E} \text{P} \text{S} \text{E} \text{S}$, Prophetess of Neith and Hathor Mistress of the Sycamore in all her places, etc.

MARIETTE, *Mastabas*, pp. 297-8, with plan of chapel.

Two false-doors, one of deceased and one of wife. Texts, id. ib. p. 298.

Double-statue, deceased seated and wife, in Cairo Mus. CG 123. BORCHARDT, *Statuen*, i, Bl. 27, pp. 93-4; MARIETTE, *Album du Musée de Boulaq* (1872), on pl. 20; JÉQUIER, *Hist. civ.* fig. 124; ALDRED, *O.K. Art.* pl. 51; HORNE-MANN, *Types*, v, pl. 1179.

No. 14 [D 43]. SMENKHUPTAḤ  ITWESH , *warb*-priest of the Pyramid of Isesi, Overseer of the Two Houses of Gold, Favourite metal-worker of the Great House, etc. Temp. Isesi.

Wife, Khenut .

MARIETTE, *Mastabas*, pp. 296-7, with plan of chapel; *Rev. Arch.* iii (1846-7), p. 116 (probably this).

In Brooklyn Museum. Formerly Abbott and N.Y. Hist. Soc. Collns.

Texts, JAMES, *Corpus*, i, pls. xix-xx [37-40], cf. iii, pp. 14-15; GARDINER Notebook, 126, pp. 24-5. See *N.Y.H.S. Cat.* p. 24 [375-6].

Block with head of statue, 37.25E. PETRIE in *Anc. Eg.* (1920), pl. on p. 19 [upper]; CAPART, *L'Art ég.* iii, pl. 454; FAZZINI, *Images for Eternity*, Cat. No. 20a; *Ägyptische Kunst aus dem Brooklyn Museum* (Berlin, Ägyptisches Museum, 4 Sept.-31. Okt. 1976), No. 15; SMITH, *Hist. Eg. Sculp.* pl. 48 [a], pp. 196, 304. Head, id. *Art . . . Anc. Eg.* pl. 52 [A], p. 76; RANSOM in *The New-York Historical Society Quarterly Bulletin*, ii [1] (April 1918), fig. 1, p. 14; JAMES (E. O.), *The Ancient Gods*, pl. 17; *Brooklyn Mus. Ann. Rep.* 1948-9, fig. on p. 42; COONEY in *Brooklyn Mus. Bull.* x [3] (Spring 1949), fig. on p. 18; *Eg. Art . . . Brooklyn*, fig. 14. Text, SETHE, *Urk.* i. 192 [31 (122), C]. See JUNKER in *Anzeiger, Wien*, 87 (1950), pp. 401-2, 403-4.

Blocks with biographical text. Nos. 37.27-8E, text, SETHE, op. cit. 192-3 [31 (122), D, E] (by Steindorff). No. 37.26E, J. C[APART] in *Chron. d'Ég.* xiv (1939), fig. on p. 339; hieroglyph of *nh*-bird, KEIMER in *Ann. Serv.* xli (1942), fig. 63, p. 326.

In Vienna, Kunsthistorisches Museum.

Panel, outer jambs, lintel, and drum, from false-door, Inv. 1841, 5817-20. Texts, REINISCH, *Miramar*, Taf. xl [2, 3], p. 257 [29, 30]; VON BERGMANN, *Hieroglyphische Inschriften* [etc.], Taf. i [upper]. See JUNKER, op. cit. p. 401; *Uebersicht* (1895), pp. 32-3 [1, 2]; (1923), p. 8 [1, 2].

Others.

Blocks. Two, with titles of deceased and son; texts, MARIETTE, op. cit. pp. 296 [bottom], 297 [middle left]; SETHE, *Urk.* i. 191-2 [31 (122), A, B] (without son). Another, with names and titles of wife and eldest son Mereruka , Metal-worker in the Two Houses, etc.; texts, MARIETTE, op. cit. p. 297 [top, and middle right].

No. 15 [B 16]. 'ANKHIRIS , Master of the largesse in the Mansion of Life of Seshet, Overseer of all works of the King, etc. Dyn. IV or later.

MARIETTE, *Mastabas*, pp. 109-10, with plan of chapel.

False-door, in Cairo Mus. JE 15139. Titles and offering-list, id. ib. pp. 109-10. Name and title, DE ROUGÉ, *Inscr. hiéro.* pl. lxxxix [middle].

No. 16 [E 4]. NEFERSEHEMPTAḤ , Overseer of craftsmen of *wacbt*, Prophet of Ptaḥ and Sokari. Dyn. VI.

Wife, Hēpu , Prophetess of Ḥathor in all her places, etc.

MARIETTE, *Mastabas*, pp. 391–2, with plan.

False-door of wife. Texts, id. ib. p. 392.

No. 18 [A 1; probably S 3076]. AKHTIḤOTP , Overseer of King's harīm, Prophet of Bubastis and Khnum, etc. Early Dyn. IV.

Plan XLVII.

MARIETTE, *Mastabas*, pp. 68–70, with plan of chapel; REISNER, *Tomb Development*, pp. 169 [9], 204 [6], 261 [15], 280 [26], 364.

Passage.

(1) (a) and (b) Double-scene, deceased with priests and offering-bringers.

Two groups of blocks, in Munich, Staatl. Sammlung, ÄS 4854–5. MÜLLER (H. W.) in *Münchner Jahrb.* 3 Ser. xiv (1963), Abb. 5, 6, pp. 214–15; *Äg. Sammlung* (1966), Abb. 18; *Staatl. Sammlung* (1972), pl. 13, pp. 35–6; (1976), p. 42 with fig. on p. 43 (ÄS 4854).

Offering-room.

(2) and (3) Deceased, in Toledo (Ohio) Mus. 59.40 and Brooklyn Mus. 57.178.

(2) *The Toledo Museum of Art. Museum News*, n.s. 14 [1] (Spring 1971), *The Art of Egypt*, 1, fig. 8. (3) Upper part, *Brooklyn Mus. Bull. (Annual Report 1957–8)*, xx [1] (Winter 1959), fig. on p. 34. Text, JAMES, *Corpus*, i, pls. xvi [28], cf. iii, pp. 9–10.

(4) and (5) Three registers of estates.

(4) Names, MARIETTE, op. cit. p. 70; JACQUET-GORDON, *Domaines*, pp. 324–5 [2S4].

(5) Remains of two lower registers, in New York, M.M.A. 58.44.2; SCOTT in *M.M.A. Bull.* n.s. xix (March 1961), fig. 2, pp. 195–6; names, JACQUET-GORDON, op. cit. pp. 326–7 [3S4], cf. figs. 113–14.

(6) False-door. (a)–(d) Deceased, with titles and name.

Two groups of titles and name, MARIETTE, op. cit. p. 70; one, DE ROUGÉ, *Inscr. hiéro.* pl. xcvi [right]; WEILL, *La II^e et la III^e dynasties*, p. 314 (from MARIETTE). (a)–(b) In New York, M.M.A. 58.123; REDMOND and RORIMER in *M.M.A. Bull.* n.s. xviii (Oct. 1959), fig. on p. 35; SCOTT, op. cit. fig. 1, pp. 194–5. (c) In Kofler-Truniger Colln.; Zürich. *5000 Jahre*, Abb. 25, p. 60 [126]; MÜLLER (H. W.), *Ägyptische Kunstwerke, Kleinfunde und Glas in der Sammlung E. und M. Kofler-Truniger, Luzern*, pl. A85, pp. 53–5; WOLDERING, *Götter*, fig. on p. 229 [Kat. 43]. (d) In Toledo (Ohio) Mus. 59.39; WITTMANN in *Apollo*, lxxxi (1965), fig. 1, p. 29; *The Toledo Museum of Art. Museum News*, n.s. 14 [1] (Spring 1971), *The Art of Egypt*, 1, fig. 7.

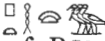
No. 19 [D 42]. KḤAḤBAUPTAḤ , Prophet of Saḥurēc, Neferirkarēc, Raḥneferēf, Neuserrēc, Prophet of Rēc and Ḥathor in the Sun-temple of Neferirkarēc, Overseer of manicurists and hairdressers of the Great House, etc. Temp. Neuserrēc or later.

MARIETTE, *Mastabas*, pp. 294–5, with plan.

Two pillars with architrave, in portico. Name and titles, id. ib. p. 294.

False-door. Lower part, id. ib. p. 295; text of lintel, DE ROUGÉ, *Inscr. hiéro.* pl. lxxxviii [top].

Two fragments of lintels with offering-text, in Chicago, Or. Inst. 10810, 10815.

No. 20 [D 41]. SEKHEM^cANKHPTAH , Overseer of the Two Granaries, Director of scribes, etc. Middle Dyn. V or later.

Plan XLVII.

SIMPSON, *The Offering Chapel of Sekhem-ankh-ptah in the Museum of Fine Arts, Boston*; MARIETTE, *Mastabas*, pp. 285–93, with plan of chapel on p. 285; L. E. R[OWE] in *Boston Mus. Bull.* viii (1910), p. 20. Titles, DE ROUGÉ, *Inscr. hiéro.* pl. lxxvii [bottom].

Offering-room. In Boston Mus. 04.1760, with additional block No. 1971.296.

(1) Remains of papyrus thicket, and registers, **I**, cow giving birth, **II**, bull mounting cow, **III**, bringing bull with calves, **IV**, servant giving drink to man in shelter, and milking cow, **V**, cattle, **VI**, butchers.

SIMPSON, op. cit. pls. C, vi–viii, fig. 4, pp. 8–10. **I–IV**, WRESZ., *Atlas*, iii. 85; see MARIETTE, op. cit. p. 290 [c] (texts of **II** and **IV**). **III** and **IV**, WHITEHILL, *Museum of Fine Arts Boston. A Centennial History*, i, fig. on p. 250. Calves in **III**, CAPART, *Documents*, ii, pl. 30 [A]; SMITH, *Hist. Eg. Sculp.* fig. 161 [top].

(2) Deceased, and registers, **I–V**, with scribe in each, **I**, bringing animals, **II**, boatmen jousting, men putting birds into cages, and netting, **III**, men sowing, driving rams treading grain, with shepherd's song, ploughing, **IV**, flax-harvest, and reaping corn, **V**, men driving [donkeys] to be loaded, and men with loaded donkeys, kiosk with food and drink, **VI** (left to right), heaping sheaves, threshing with donkeys, piling up, winnowing, and measuring corn.

SIMPSON, op. cit. pls. D, ix–xvi, figs. 5–10, pp. 10–16; WRESZ., *Atlas*, iii. 51; description and texts, MARIETTE, op. cit. pp. 287–9 [b]. Deceased, and right end of **III–VI**, FISCHER in *Bulletin of The Detroit Institute of Arts*, 51 (1972), fig. 7 on p. 78. Left part of **I–IV**, SMITH, *Hist. Eg. Sculp.* pl. 55 [a], p. 194. Bringing stag and hyena in **I**, left part of **III–V**, and two men and baby donkey in **VI**, id. *Country Life*, figs. 24, 31–2. Boatmen jousting in **II**, donkey-men and scribe in **V**, and two men and baby donkey in **VI**, D. D[UNHAM] in *Boston Mus. Bull.* xxvii (1929), figs. on pp. 35–6. Four boatmen in **II**, ALDRED, *Jewels of the Pharaohs*, pl. 17. **III**, men with rams, and shepherd's song, including new block, No. 1971.296 (from Michaelidis Colln.), SEIBERT, *Die Charakteristik* [etc.], i, Abb. 1, pp. 57–8 [1]; No. 1971.296, GOEDICKE in *W.Z.K.M.* 54 (1957), pp. 46–50 with pl.; SIMPSON in *Apollo*, xcvi (1973), fig. 1, p. 251; see id. in *96th Annual Report 1971–2*, p. 51; text of shepherd's song, KAPLONY in *Chron. d'Ég.* xlv (1969), pp. 30 [S], cf. 27–9; ALTENMÜLLER in ib. xlviii (1973), pp. 212 [3], cf. 211. Right half of **IV** and **V**, WHITEHILL, op. cit. fig. on p. 251. **VI**, two men and baby donkey, CAPART, *Memphis*, fig. 368; id. *Documents*, ii, pl. 32; SMITH, *Anc. Eg.* (1942), fig. 30; (1952), fig. 31; PIJOÁN, *Summa Artis*, iii (1945), fig. 201; PIRENNE, *Hist. civ.* i, pl. 79 [lower] facing p. 256; one man heaping sheaves and another piling up corn, GHALIOUNGUI in *Bull. Inst. Ég.* xlv (1962–3), pl. i, p. 41; man piling up corn, HOYNINGEN-HUENE and STEINDORFF, *Egypt* (1945), fig. on p. 22.

(3) [1st ed. 4] Deceased at table, offering-list, offerings, and three registers of offering-bringers and butchers.

SIMPSON, *The Offering Chapel* [etc.], pls. A, i–iii, fig. 2, pp. 4–6. Some offering-bringers and butchers, SMITH, *Anc. Eg.* (1942), fig. 31; (1952), fig. 32; (1960), fig. 34; WRESZ., *Atlas*, iii. 55 [C], 93 [B]; HOYNINGEN-HUENE and STEINDORFF, op. cit. fig. on p. 21; MAZAR,

Views, i, pl. 287. Butchers, EGGBRECHT, *Schlachtungsbräuche im Alten Ägypten* [etc.], Taf. iv, pp. 205-7 [c]; one with knife and bowl, FISCHER in *Artibus Asiae*, xxii (1959), fig. 14, p. 251. See MARIETTE, op. cit. pp. 286-7 [a] (texts).

(4) [1st ed. 3] False-door.

SIMPSON, *The Offering Chapel* [etc.], pls. B, iv, v, fig. 3, pp. 7-8; MARIETTE, op. cit. pp. 290-3 [d]; GARDINER MSS. photos. 28.394-5; incomplete, PIJOÁN, op. cit. fig. 190; panel, FISCHER in *J.A.R.C.E.* ii (1963), fig. 7, pp. 30-1; part of right inner jamb, CAPART, *Memphis*, fig. 178.

No. 21 [D 40]. $\text{ANKHMA}^{\text{RE}} \text{C}^{\text{RE}} \text{—} \text{—} \text{—} \text{—} \text{—}$, Supervisor of prophets of the Pyramids of Raⁿeferef and Menkauhor, Prophet of Rē^c in the Sun-temple of Menkauhor, Overseer of manicurists of the Great House, etc. Temp. Menkauhor or later.

MARIETTE, *Mastabas*, pp. 280-4, with plan of chapel on p. 280.

Offering-room. E of Mariette. Painted decoration.

North and south walls. Deceased seated, with offering-bringers and butchers; some texts, id. ib. pp. 281-2; text of offering-bringers with haunches, id. in *Rev. Arch.* n.s. xix (1869), pl. iv [c, top] facing p. 87.

West wall. False-door; id. *Mastabas*, pp. 282-4.

No. 22 [D 39]. $\text{KAPURÉ}^{\text{C}} \text{—} \text{—} \text{—} \text{—} \text{—}$, Prophet of the Pyramid of Isesi, Overseer of the Treasury of the Residence, etc. Temp. Isesi or later.

Plan XLVII.

MARIETTE, *Mastabas*, pp. 272-9, with plan of Chapel on p. 272.

Chapel. In Philadelphia Mus. E 15729.

View, *Penn. Mus. Journ.* xvii (1926), pl. on p. 117; DAM in ib. xviii (1927), pl. on p. 188. See RANKE in *Penn. Mus. Bull.* xv [2-3] (Nov. 1950), pp. 95-8.

(1) (a) Small boat, and three large rowing-boats below. (b) [1st ed. 1] One small and two large sailing-boats.

(a) P. M[ILLER] in ib. 7 [3] (April 1939), pl. xiv [lower], p. 29. (b) Two large boats, id. ib. pl. xiv [upper], pp. 26, 29; lower boat, BASS, *A History of Seafaring*, fig. 15 on p. 28. Texts, MARIETTE, op. cit. p. 272; part, ERMAN, *Reden, Rufe und Lieder*, p. 55.

(2) [1st ed. 4, incorrectly placed] Before deceased with son, I-II, estates and bringing animals, III, cranes, and below, two registers of offering-bringers and butchers, continued at (3)-(4).

Right part, DAM, op. cit. pl. on p. 192; two groups of butchers, P. M[ILLER], op. cit. fig. 5, p. 30. Texts, MARIETTE, op. cit. pp. 275-7 [e]; of watching estates, id. in *Rev. Arch.* n.s. xix (1869), pl. iii [b, 3rd col.] (probably) facing p. 82; names of estates, JACQUET-GORDON, *Domaines*, pp. 373-4 [20S5], cf. figs. 145-6.

(3)-(4) [1st ed. 2-3] (right to left) Deceased at table, with [offering-list], priests, and offerings, and two registers of offering-bringers below, continued from (2).

(3) DAM, op. cit. pls. on pp. 195, 198. Texts, MARIETTE, *Mastabas*, pp. 274-5 [d].

(5) False-door.

Id. ib. pp. 278-9; text of lintels (incomplete), DE ROUGÉ, *Inscr. hiéro.* pl. xc; of upper lintel, DUEMICHEN, *Altaegyptische Kalenderinschriften* [etc.], xli [a]; of lower lintel and inner jambs (reversed), id. *Resultate*, Taf. vii; of right inner jamb, SETHE, *Urk.* i. 177 [21 (112), B].



(6) Deceased at table, with offering-list, offerings, butchers, and offering-bringers.

Two groups of butchers, P. M[ILLER], op. cit. fig. 4, p. 29. Texts, MARIETTE, *Mastabas*, pp. 273-4 [c]; of butchers, id. in *Rev. Arch.* n.s. xix (1869), pl. iv [c, bottom] facing p. 87.

No. 23 [E 5]. KEDNAS , Judge and Overseer of scribes, etc. Dyn. VI.

MARIETTE, *Mastabas*, pp. 392-3, with plan of chapel on p. 392 [lower].

False-door. Id. ib. p. 393.

No. 24 [D 38]. WASHPTAḤ  ISI , Chief Justice and Vizier, etc. Temp. Neferirkarêc.

MARIETTE, *Mastabas*, pp. 267-71, with plan of chapel on p. 267 [lower].

False-door, in Copenhagen, Nationalmuseet, 5129 (additional fragment found by Edel in 1970), architrave (top line now lost) in Brit. Mus. 1278, and offering-list. Id. ib. pp. 267-71. Copenhagen 5129, MOGENSEN, *Inscriptions hiéroglyphiques du Musée National de Copenhague*, pls. x, xi [12], pp. 7-11; *Egypt and Western Asia* (1968), pl. on p. 21, cf. p. 19 [8]; titles from upper lintel and left inner jamb (reversed), DE ROUGÉ, *Inscr. hiéro.* pls. xcvi [upper], xcvi [upper]; see *Guide. Oriental and Classical Antiquity* (1950), p. 16 [8] (as Idy). Additional fragment, see LECLANT in *Orientalia*, n.s. 40 (1971), p. 231 [b]. Brit. Mus. 1278, *Hiero. Texts*, i, pl. 10 [66]; i², pl. xxi [2], pp. 20-1; see *Guide (Sculpture)*, p. 20 [66].

Jambs and thicknesses of doorway, deceased with sons, account of his death in presence of Neferirkarêc, and record of endowment; blocks, from left (C, D of Sethe), in Cairo Mus. CG 1570, 1673, 1702, JE 55937, and Aberdeen Mus. 1560 (formerly 1535), 1558c (formerly 1546), and from right (A, B of Sethe), in Cairo Mus. CG 1569, 1674, and Aberdeen Mus. 1558a, b (formerly 1526, 1529). From left, Cairo blocks, BORCHARDT, *Denkmäler*, ii, Bl. 70, pp. 42, 129, 144; jamb, GRDSELOFF in *Ann. Serv.* li (1951), pl. i, p. 129; from right, Cairo blocks, BORCHARDT, op. cit. Bl. 69, pp. 40-1, 129; parts of CG 1569, GRDSELOFF in *Ann. Serv.* xxxviii (1938), fig. 57, pp. 353-4. Texts, SETHE, *Urk.* i. 40-5 [27]. Aberdeen blocks, see REID, *Illustrated Catalogue* [etc.] (1912), p. 195.

No. 25 [C 3]. PTAḤUSER , Overseer of gold-workers of King's adorners, etc. Middle Dyn. V or later.

MARIETTE, *Mastabas*, pp. 115-17, with plan.

False-door. Texts, id. ib. p. 116.

No. 26 [D 37]. MANŪFER , Overseer of scribes of the royal documents, etc. Late Dyn. VI.

Parents, probably, Sekhemka and Iti (tomb No. 54 [C 19]).

MARIETTE, *Mastabas*, pp. 266-7, with plan.

False-door. Id. ib. p. 266.

Statues. Probably from here.

Deceased as scribe reading, granite, in Cairo Mus. CG 56. BORCHARDT, *Statuen*, i, Bl. 14, pp. 50-1; WEIGALL, *Anc. Eg. . . . Art*, 68 [upper right]; VON BISSING, *Äg. Kunstgeschichte*, Taf. lxx [397], *Text*, i, p. 81; id. *Einführung in die Geschichte der Ägyptischen Kunst* [etc.], Taf. iii [1]; HORNEMANN, *Types*, ii, pl. 408; PETRIE GIZA photos. 521-2.

Double-statue, deceased seated and wife, formerly in Caylus Colln., now in Paris, Bibliothèque Nationale. CAYLUS, *Recueil d'Antiquités Égyptiennes* [etc.], v (1762), pl. xx, pp. 57-61; CAPART, *Recueil*, i, pl. ix; SHOUKRY, *Privatgrabstatue*, Abb. 24.

No. 27 [D 36]. IYKAU , Overseer of scribes of the crews. Dyn. V.

Wife, Khenut , Royal acquaintance.

MARIETTE, *Mastabas*, pp. 264-5.

Upper part of false-door. Id. ib. p. 265 [lower].

Statues. In Cairo Museum.

Deceased seated, CG 27. BORCHARDT, *Statuen*, i, Bl. 7, pp. 27-8; HORNEMANN, *Types*, iii, pl. 702; MICHALOWSKI, *Art*, fig. 205; text, MARIETTE, op. cit. p. 265 [upper].

Statue-group, deceased, wife, and small son, with small daughter kneeling, CG 105. BORCHARDT, op. cit. Bl. 23, pp. 82-3.

Niche with deceased, CG 106. Id. ib. Bl. 23, pp. 83-4.

No. 28 [D 35]. RAḤOTPI , Inspector of scribes of the royal documents. Dyn. V.

MARIETTE, *Mastabas*, pp. 263-4, with plan of chapel.

Statue¹ of deceased, in Cairo Mus. CG 205. BORCHARDT, *Statuen*, i, Bl. 43, pp. 138-9. Name and title, MARIETTE, op. cit. p. 264. See MASPERO, *Guide*, p. 72 [159].

No. 29 [D 34]. PTAḤSHEPSES , Scribe of the royal documents. Dyn. V.

MARIETTE, *Mastabas*, p. 263.

Scribe-statue of deceased, granite, in Cairo Mus. CG 186. BORCHARDT, *Statuen*, i, Bl. 40, p. 128.

No. 30 [D 33]. SHEPSI , Judge and Elder of the Hall. Dyn. V.

Wife, Nikauḥathor , Prophetess of Neith, etc.

MARIETTE, *Mastabas*, p. 262, with plan of chapel.

Statue-group, deceased seated, with wife and small son Shepsipuzad-nezes (tomb No. 31 [D 32]), in Cairo Mus. CG 22. BORCHARDT, *Statuen*, i, Bl. 6, pp. 23-4; VON BISSING, *Äg. Kunstgeschichte*, Taf. lxxiii [385], *Text*, i, p. 87; HORNEMANN, *Types*, v, pl. 1411; PETRIE GIZA photo. 537. Text, MARIETTE, op. cit. p. 262 [bottom]; DE ROUGÉ, *Inscr. hiéro.* pl. liv [bottom].



¹ The statue might, however, come from tomb No. 66 [C 24], see LANSING in *M.M.A. Bull.* xxi (1926), pp. 41-2. There is no other evidence for ascribing the tomb.





No. 31 [D 32]. SHEPSIPUZAD , Judge and Elder of the Hall. Dyn. V.

Parents, Shepsi and Nikauhathor (tomb No. 30 [D 33]).

MARIETTE, *Mastabas*, pp. 261-2.

Statue of deceased, in Cairo Mus. CG 212. BORCHARDT, *Statuen*, i, Bl. 44, p. 142. Text, MARIETTE, op. cit. p. 262 [top]; DE ROUGÉ, *Inscr. hiéro.* pl. liv [near top].

No. 32 [D 31]. 'ANKH-KAKAI  , Official (*iry-ht*) of the Chamber of unguents of King's adorners, Inspector of officials (*srw*), etc. Advanced Dyn. V or later.

Wife, Nitankh-hathor    , Prophetess of Hathor.

MARIETTE, *Mastabas*, p. 261.



False-door, in Cairo Mus. CG 1424. Texts, BORCHARDT, *Denkmäler*, i, pp. 105-6. Names, DE ROUGÉ, *Inscr. hiéro.* pls. iv [top], lxii [top right].

Offering-basin, in Cairo Mus. CG 1326. BORCHARDT, op. cit. Bl. 4, p. 11.

No. 33 [D 30]. KHNEMHOTP  , Scribe of the granary. Probably Dyn. V.



MARIETTE, *Mastabas*, p. 260.

Statue of deceased, in Cairo Mus. CG 96. BORCHARDT, *Statuen*, i, Bl. 22, p. 76. Text, MARIETTE, op. cit. p. 260.

No. 34 [D 29]. RA'WĒR  , Steward. Dyn. V.

MARIETTE, *Mastabas*, p. 260.

Statue of deceased, in Cairo Mus. CG 29. BORCHARDT, *Statuen*, i, Bl. 8, p. 29; MASPERO, *Égypte*, fig. 26. Text, MARIETTE, op. cit. p. 260.

No. 35 [C 20]. KAI  , Judge and Boundary official. Early Dyn. V.

Mother, Mesehti  , Royal acquaintance.

MARIETTE, *Mastabas*, p. 151, with plan of chapel; id. *Sérapeum*, *Texte*, p. 11 with note 1; SMITH (W. S.) in REISNER, *Tomb Development*, p. 400.

Statues. In Louvre.

Deceased seated, A 106 [N.117; E.3024]. CAPART, *Recueil*, i, pls. vi, vii; id. in *J.E.A.* vii (1921), pl. xxxi [2], pp. 188-90; id. *L'Art ég.* ii, pl. 244; id. *Limites*, pl. iii [5], p. 44; RICHER, *Le Nu*, figs. 43 [right], 60; *Encycl. phot. Louvre*, i, pls. 32-3; PIJOÁN, *Summa Artis*, iii (1945), figs. 160-1; ARCHIVES phot. E. 64; WILKINSON MSS. xxiv. 10 [bottom left]. Upper part, BOREUX, *Sculpture*, pl. xi; VANDIER, *Manuel*, iii, pl. xix [6], p. 573. Head, PETRIE, *Egypt* in *Encyclopaedia Britannica* (1910), pl. iii [32] facing p. 66; MALRAUX, *Le Musée imaginaire de la sculpture mondiale*, pl. 37. See DE ROUGÉ, *Notice des monuments* (1883), p. 49; BOREUX, *Guide*, i, pp. 237-8; VANDIER, *Guide* (1948 and 1952), p. 9; (1973), p. 15.

Squatting scribe¹ writing, no name, 'Scribe du Louvre' or 'Scribe rouge', N.2290. MARIETTE, *Choix de monuments*, pl. x, pp. 11-12 (repr. in *Bibl. Ég.* xviii, pl. x, pp. 318-19); PERROT and CHIPIEZ, *Hist. de l'Art*, i, pl. x, p. 646; MASPERO, *Hist. anc.* i, pl. 3, pp. 408-9

¹ Selected references.

with note 1; id. *Essais*, pl. ii facing p. 54, cf. pp. 53-7; id. *Eg. Art*, pl. facing p. 60, cf. pp. 60-5; id. *Scribe accroupi* in RAYET, *Monuments de l'art antique*, i, Livraison II, pl. xiii; CAPART, *Memphis*, fig. 268; id. *L'Art ég.* ii, pls. 245-6; id. *Documents*, ii, pls. 13-15; id. in *J.E.A.* vii (1921), pl. xxxi [1], pp. 186, 190; VON BISSING, *Denkmäler*, i, Taf. 11B, *Text* to Taf. 11B [fig.]; id. *Äg. Kunstgeschichte*, Taf. lxx [394], *Text*, i, p. 81; WEIGALL, *Anc. Eg. . . . Art*, 48 [right]; ROSS, *The Art of Egypt*, pl. on p. 107; *Encycl. phot. Louvre*, i, pls. 29-31; POULSEN, *Äg. Kunst. A. und M.* pl. on p. 66; SCHÄFER and ANDRAE, *Kunst* (1925), 227; (1930), 237; (1942), 239; VANDIER, *Manuel*, iii, pl. xviii [4, 5], p. 573; id. *Guide* (1948 and 1952), pl. iii, p. 10; (1973), pl. iii, p. 16; RANKE, *The Art of Ancient Egypt*, and BREASTED, *Geschichte Aegyptens* (1936), 66-7; WOLF, *Kunst*, Abb. 127-8; SMITH, *Hist. Eg. Sculp.* pl. 18 [a], p. 47; ALDRED, *O.K. Art*, pl. 40; LANGE and HIRMER, *Aegypten. Architektur* (1955 and 1957), pl. 60; (1967), pls. 60-1; DESROCHES-NOBLECOURT, *L'Art ég.* fig. 21; BOREUX, *Guide*, ii, pl. lviii, pp. 443-4; YOYOTTE, *Treasures*, pl. on p. 31; MICHALOWSKI, *Art*, figs. 74, 211; DE ROUGÉ, *Notice sommaire* (1895), pl. on p. 82, cf. p. 80; see (1855), p. 66; HARRIS in *J.E.A.* 41 (1955), pp. 122-3.

No. 36 [C 8]. KA^cAPER $\text{K} \overline{\text{A}} \overline{\text{P}} \overline{\text{E}} \overline{\text{R}}$, Chief lector-priest. Late Dyn. IV or early Dyn. V.

MARIETTE, *Mastabas*, pp. 127-9, with plan on p. 127. Plan of chapel, MURRAY, *Saqqara Mastabas*, i, pl. xxxii [top right].

Chapel.

False-door, granite. Name and title, MARIETTE, op. cit. p. 128; MURRAY, op. cit. i, pl. iii [5]; SETHE in ib. ii, p. 13 [17].



Offering-table of Hetepherakhti, alabaster, originally probably from tomb D 60, in Cairo Mus. CG 1304. BORCHARDT, *Denkmäler*, i, Bl. 1, pp. 4-5; MARIETTE, op. cit. fig. on p. 348, cf. p. 129; MURRAY, op. cit. i, pl. iii [4], p. 4 [6]; text, SETHE in ib. ii, pp. 12-13 [16].

Statue¹ of man, 'Sheikh el-Beled', and upper part of statue¹ of woman, 'Wife of Sheikh el-Beled', both wood, in Cairo Mus. CG 34, 33. BORCHARDT, *Statuen*, i, Bl. 9, pp. 31-3; CAPART in *J.E.A.* vi (1920), pls. xxiii, xxvii [1, 2], pp. 227-33; id. *Memphis*, figs. 247-8, 328; id. *L'Art ég.* ii, pls. 250-1, 253; MASPERO, *L'Arch. ég.* (1887), figs. 183-5; (1907), figs. 194-6; id. *Égypte*, figs. 151-2, 154; VON BISSING, *Denkmäler*, i, Taf. 11, *Text* to Taf. 5 [1st fig.]; id. *Äg. Kunstgeschichte*, Taf. lii [346], liii [347], lvi [354], *Text*, i, p. 81; WEIGALL, *Anc. Eg. . . . Art*, 40-2; RANKE, *The Art of Ancient Egypt*, and BREASTED, *Geschichte Aegyptens* (1936), 69, 70, 72; PIJOAN, *Summa Artis*, iii (1945), figs. 150-1, 155; *Encycl. phot. Caire*, pls. 16-18, 32; WOLF, *Kunst*, Abb. 137, 139; MICHALOWSKI, *Art*, figs. 72, 216; DONADONI, *Egyptian Museum Cairo*, pls. on pp. 38, 39 [right]; *Great Museums*, pls. 18, 19, fig. on p. 47; heads, CAPART, *Documents*, i, pls. 6, 9; id. *L'Art ég.* (1911), pls. 112, 114; PETRIE, *Arts and Crafts*, figs. 25-6 facing p. 33; see MASPERO, *Guide*, pp. 55 [117], 64-6 [140] with fig. 17; *Descr. somm.* Nos. 117, 140, cf. pl. after p. 26 [140]. CG 34, PERROT and CHIPIEZ, *Hist. de l'Art*, i, fig. 7; MARIETTE, *Album du Musée de Boulaq* (1872), pls. 18, 19; MASPERO, *Hist. anc.* i, pl. 1 (frontispiece), fig. on p. 408 [left]; BOREUX, *L'Art ég.* pl. xxvii; SPIEGELBERG, *Geschichte*, i (1903), Abb. 31; STEINDORFF, *Kunst*, 187; SCHÄFER and ANDRAE, *Kunst* (1925), 229; (1930), 239; (1942), 237; ROSS, *The Art of Egypt*, pl. on p. 106 [1]; SMITH, *Hist. Eg. Sculp.* pl. 18 [c], pp. 48-9; LANGE and HIRMER, *Aegypten. Architektur* (1955 and 1957), pls. 54-5; (1967), pls. 58-9; ANGIOLETTI and BIGONGIARI, *Testimone*, Tav. 6; GROENEWEGEN-FRANKFORT and ASHMOLE, *Art of the Ancient World*, fig. 34; GRIFFITH INST. photo. 342

¹ Selected references.

(SEBAH, 121); upper part, BORCHARDT, *Works of Art*, pl. 2; see MURRAY, *Saqqara Mastabas*, i, p. 4 [6].

Nos. 37-8 [E 1, 2 and H 3].

SABU  IBEBI , Greatest of the Directors of craftsmen in the Two Houses on the day of the festival, Supervisor of prophets of the Pyramids of Unis and Teti, Prophet of Rē in the Sun-temples of Userkaf, Neferirkarē, Neuserre and Menkauhor, etc. Temp. Teti.

PTAḤSHEPSES [II] , Supervisor of prophets of the Pyramid of Teti, Prophet of the Pyramid of Unis, Greatest of the Directors of craftsmen in the Two Houses, etc. Temp. Teti or later.

Wife, Inti , Prophetess of Ḥathor and Neith, etc.

Plan XLVII.

MARIETTE, *Mastabas*, pp. 373-85, 386-8 [2, 3], 444, with plan on p. 374. Names, LIEBLEIN, *Dict.* No. 29.

South chapel. Sabu.

(1) Doorway. (a)-(b) [1st ed. 1-2] Architrave with [figures of deceased], lintel with offering-text, and jambs with titles; (c) and (d) thicknesses with deceased and family, and titles.

Texts, MARIETTE, op. cit. pp. 375-6, cf. fig. on p. 374 [bottom]; of jambs, SETHE, *Urk.* i. 81 [5, A, B]; some titles, DE ROUGÉ, *Inscr. hiéro.* pls. xciv [bottom, left and middle], xcvi [top right]; id. *Recherches sur les monuments* [etc.] (1866), p. 110 [upper] (repr. in *Bibl. Ég.* xxvi, p. 105 [upper]).

(2) [1st ed. 3] Deceased at table, with offering-list, priests and offerings, and below, two registers of offering-bringers, in Cairo Mus. CG 1418.

BORCHARDT, *Denkmäler*, i, Bl. 21, pp. 91-5. Offering-list, HASSAN, *Giza*, vi [2], pls. xcvi-cv [102], p. 141. Two bottom registers, MARIETTE, op. cit. fig. on p. 380 (reversed). See MASPERO, *Guide*, p. 26 [33 B].

(3) [1st ed. 5] Registers, I-II (upper part of I lost) deceased carried in palanquin, with attendants, including one with baboons, III, offering-bringers, IV, dragging a seated and a standing statue, V, estates, VI, butchers, VII, two boats, with men hoisting mast in one of them, VIII, deceased seated, with scribe counting cattle, in Cairo Mus. CG 1419.

BORCHARDT, *Denkmäler*, i, Bl. 21, pp. 96-101; MARIETTE, op. cit. figs. on pp. 381-4 (partly reversed). II-VIII, MASPERO, *Égypte*, fig. 109. IV-VIII, BORCHARDT, *Works of Art*, pl. 22. V-VI, and left boat in VII, ROSTOVZEFF, *A History of the Ancient World*, i, pl. xi [1, 2]. Two estates, JACQUET-GORDON, *Domaines*, pl. iii facing p. 416. Names of estates, id. ib. pp. 416-18 [37S6], cf. figs. 175-6; DE ROUGÉ, *Inscr. hiéro.* pl. xcvi [bottom right]. First group of butchers, CHASSINAT in *B.I.F.A.O.* iv (1905), fig. 1, p. 223. VII-VIII, CAPART, *Rue de Tombeaux*, pl. cvi. VII, WRESZ., *Atlas*, iii. 112. Left boat, CLARKE and ENGELBACH, *Ancient Egyptian Masonry*, fig. 44; part, BELGER in *Ä.Z.* xxxiii (1895), fig. 14, p. 31. Herdsman in VIII, BORCHARDT in ib. 44 (1907), Abb. 5, p. 79. See MASPERO, *Guide*, p. 26 [33C].

(4) False-door, in Cairo Mus. CG 1565.

BORCHARDT, *Denkmäler*, ii, Bl. 65, pp. 31-4; MARIETTE, *Mastabas*, figs. on pp. 412-15 (E 12 for E 1, 2), cf. p. 379. Texts from lintels and jambs, SETHE, *Urk.* i. 82-4 [5, C, D]

(copied by Erman), 177 [21 (112), C]; DE ROUGÉ, *Inscr. hiéro.* pls. xciii, xciv [top], xciv [left]. Two titles, id. *Recherches sur les monuments* [etc.] (1866), pp. 110 [lower]-113 (repr. in *Bibl. Ég.* xxvi, pp. 105 [lower]-109). See MASPERO, *Guide*, p. 26 [33A].

North chapel. Ptaḥshepses [II].

MURRAY, *Saqqara Mastabas*, i, pp. 26-8; plan, pl. xxxv [middle right]; texts, SETHE in *ib.* ii, pp. 21-3 [24].

(5) [1st ed. 1-4] Doorway. (a)-(b) Lintel with offering-text and drum with titles; (a) and (b) jambs, deceased and wife; (c) and (d) deceased with children, and offering-bringers below. Four blocks from lintel, drum, and block with deceased, son Ptaḥshepses, Supervisor of craftsmen, and a daughter, from (d), in Liverpool, Merseyside County Museums, 55.67.

(a)-(b) Text of lintel, MARIETTE, *op. cit.* p. 377 [B]; of lines 3-6, DE ROUGÉ, *Inscr. hiéro.* pl. xcii; of line 6, id. *Recherches sur les monuments* [etc.] (1866), p. 109 (repr. in *Bibl. Ég.* xxvi, p. 104); of drum, MARIETTE, *op. cit.* p. 378 [middle]. Left end of lintel, MURRAY, *op. cit.* i, pl. xxxi [4]. (a)-(d) Fragments of jambs and thicknesses, id. *ib.* pl. xxxi [1-3, 7]; texts, MARIETTE, *op. cit.* pp. 377-8 [C, C', D']; titles of wife, DE ROUGÉ, *Inscr. hiéro.* pl. xciv [bottom right]. Two unplaced fragments, MURRAY, *op. cit.* pl. xxxi [5, 6].

(6) and (7) [1st ed. 5, 7] Deceased at table, offering-list, and four registers of butchers, offerings, and offering-bringers.

Id. *ib.* pls. xxx, xxix; some names and titles at (7), MARIETTE, *op. cit.* pp. 378-9.

(8) [1st ed. 6] False-door. MURRAY, *op. cit.* i, pl. xxviii.

No. 39 [C 16]. SABU , *mḥnk* of the King. Dyn. V-VI.

Plan XLVII.

MARIETTE, *Mastabas*, pp. 142-7, with plans and details, pp. 143, 147. Plan and sections, PRISSE, *L'Art ég.* i, *Architecture*, 7th pl. 'Tombeaux . . . Memphis' [i], *Texte*, p. 352. View, PERROT and CHIPIEZ, *Hist. de l'Art*, i, fig. 106.

Chapel.

(1) Doorway. (a) Registers, I, deceased seated and son Ptaḥshepses, with scribes and defaulters, II-V, bringing cattle and fowl. (b) Deceased with small son, and registers, I, scribes, II-IV, offering-bringers. (c) and (d) Deceased with son.

(a), (b) DE ROUGÉ, *Album photo.* pls. 89, 90; MARIETTE, *Voyage*, i, pls. 5, 6, pp. 35-7; RHONÉ in *Gazette des Beaux-Arts*, 2 Pér. xxiv (1881), fig. on p. 253; texts, MARIETTE, *Mastabas*, pp. 144-6. (b) MORET, *Le Nil*, pl. vi [2]; EBERS, *Aegypten*, i, fig. on p. 182; Eng. ed. fig. on p. 159 (as Ty); man with gazelle in III, BULLE, *Der schöne Mensch im Altertum* (1898), Taf. 10; (1912), Taf. 20; CAROTTI, *L'Arte*, fig. 32. (c) and (d) See MARIETTE, *Mastabas*, p. 146 [bottom].

No. 40 [C 5]. RA^cNÜFER , Greatest of the Directors of craftsmen on the day of the festival, etc. Early Dyn. V.

Wife (probably), Heknu , Royal acquaintance.

MARIETTE, *Mastabas*, pp. 121-3, with plan showing relation to other tombs.

Statues. In Cairo Museum. Texts, id. ib. p. 123.

Two,¹ deceased with longer kilt, and with short kilt and wig, CG 18, 19. BORCHARDT, *Statuen*, i, Bl. 5, pp. 19–20; PERROT and CHIPIEZ, *Hist. de l'Art*, i, figs. 6, 49, 436–7 (CG 18 reversed); CAPART, *L'Art ég.* (1909), pl. 13 (CG 19); (1911), pls. 110–11 (head of CG 19, and CG 18); id. *L'Art ég.* ii, pls. 236–9; id. *Memphis*, figs. 324–5; id. in *J.E.A.* vi (1920), pl. xxvi, pp. 226–7; WEIGALL, *Anc. Eg. . . . Art*, 45–7; STEINDORFF, *Kunst*, 185–6; MASPERO, *Guide*, figs. 31–2, pp. 83–4 [224–5]; SPIEGELBERG in *A.Z.* 54 (1918), Taf. i, pp. 70–1; VON BISSING, *Äg. Kunstgeschichte*, Taf. lvi [355–6], *Text*, i, p. 84; HAMANN, *Äg. Kunst*, Abb. 133–5; PIJOÁN, *Summa Artis*, iii (1945), figs. 152–3; HORNEMANN, *Types*, i, pls. 119, 118; ANTHES, *Meisterwerke*, Taf. ix, x; id. *Aeg. Plastik*, Taf. 9, 10; WOLF, *Kunst*, Abb. 119–22; LANGE and HIRMER, *Aegypten. Architektur* (1955 and 1957), pls. 61–5; (1967), pls. 52–7; WOLDERING, *Götter*, Abb. 32–3 (only head of CG 18); SMITH, *Hist. Eg. Sculp.* pl. 18 [b, d] (only head of CG 18), p. 49; *Great Museums*, pl. 20, fig. on p. 215 [62]; DONADONI, *Egyptian Museum Cairo*, pls. on pp. 42 [left], 40–1 (numbers reversed); GROENEWEGEN-FRANKFORT and ASHMOLE, *Art of the Ancient World*, figs. 27–9; incomplete, LANGE, *Äg. Kunst*, pls. 24, 29; see ENGELBACH in *Mélanges Maspero*, i [1], pp. 101–3 with pl. CG 18, MEIER-GRAEFE, *Pyramide und Tempel*, Taf. 10. CG 19, PRISSE, *L'Art ég.* ii, *Sculpture*, 32nd pl. 'Chafré, écrivain', *Texte*, pp. 408–9; MASPERO, *Hist. anc.* i, fig. on p. 47; id. in *Gazette des Beaux-Arts*, 3 Pér. ix (1893) [1], fig. on p. 265; SPIEGELBERG, *Geschichte*, Abb. 26; ROSS, *The Art of Egypt*, pl. on p. 106 [2]; FECHHEIMER, *Plastik*, Taf. 32–3; RANKE, *The Art of Ancient Egypt*, and BREASTED, *Geschichte Aegyptens* (1936), 68; PETRIE, *Arts and Crafts*, fig. 31 facing p. 35; *Encycl. phot. Caire*, pls. 23–5; ALDRED, *O.K. Art*, pl. 35; TERRACE and FISCHER, *Treasures*, pp. 57–60 with pls.

Heknu seated, CG 53. BORCHARDT, *Statuen*, i, Bl. 14, pp. 46–7; CAPART, *L'Art ég.* (1911), pl. 115; id. *L'Art ég.* ii, pl. 235; HORNEMANN, *Types*, iv, pl. 1042; SHOUKRY, *Privatgrabstatue*, Abb. 16. See MASPERO, *Guide*, p. 67 [148].

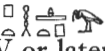
Nos. 41–2 [C 6 and 7 and probably F 4]. PTAḤḤOTP-DESHER  and PTAḤḤOTP, both Chief Justice and Vizier, etc. Middle Dyn. V or later.

Plan XLVII.

MARIETTE, *Mastabas*, pp. 123–6, with plan, fig. on p. 124; MURRAY, *Saqqara Mastabas*, i, pp. 5–7, with plan, pl. xxxv [top left]. Plan, MASPERO, *L'Arch. ég.* (1887), fig. 122; (1907), fig. 127. Titles, SETHE in MURRAY, op. cit. ii, p. 13 [18, 19].

I. Central Court.

(1) False-door of Ptaḥḥotp.

Panel, and lintel with offering-text, MURRAY, op. cit. i, pl. iv [upper].

II. South Chapel. Ptaḥḥotp-deshēr.

Two obelisks, Ptaḥḥotp-deshēr and woman 'Ankhkaus , probably from here, in Cairo Mus. CG 1308, 1312. BORCHARDT, *Denkmäler*, i, Bl. 2, pp. 6, 7; KUENTZ, *Obélisques (Cat. Caire)*, pl. i, pp. 1–2, 5–6; MARIETTE, op. cit. figs. on p. 434. CG 1308, MASPERO, *Égypte*, fig. 65 [right]; name of phyle, SETHE, *Urk.* i. 58 [41]; see MASPERO, *Guide*, p. 45 [83A].

(2) [1st ed. 4–6] Doorway. (a)–(b) Lintel with offering-text; (c) drum with name and titles.

MURRAY, op. cit. i, pl. vi [1, 3]; text, MARIETTE, op. cit. pp. 124 [bottom], 125 [top].

¹ Selected references.

(3) [1st ed. 7] Chair from painted scene, MURRAY, op. cit. i, pl. vi [2].

North Chapel. Ptahhotp.

III. Portico.

(4) and (5) [1st ed. 2, 3] Pillars with titles, probably in Cairo Mus. JE 15048.
Texts, id. ib. pl. iv [lower]; one, MARIETTE, op. cit. p. 125.

IV. Inner Room.

(6) False-door, in Cairo Mus. CG 1467.

BORCHARDT, *Denkmäler*, i, Bl. 38, pp. 156-7; MURRAY, op. cit. i, pl. v; texts, MARIETTE, op. cit. pp. 126, cf. 125; incomplete, VASSALLI MSS. 13; see MASPERO, *Guide*, p. 28 [39].

No. 43 [C 17]. INTI  , Real royal acquaintance (woman). Dyn. VI.

MARIETTE, *Mastabas*, p. 148, with plan.

Lower part of false-door. Name and title, id. ib. p. 148.

Left of false-door, Thety (tomb, probably, No. 47 [E 3]), in Munich, Staatl. Sammlung, Gl. 13. FURTWÄNGLER, *Ein hundert Tafeln nach den Bildwerken der Kgl. Glyptothek zu München* (1903), Taf. 6; *Äg. Sammlung* (1966), Abb. 13; *Staatl. Sammlung* (1976), pp. 44-5 with fig.; MARBURG INST. photo. 606948. See FURTWÄNGLER, *Beschreibung der Glyptothek Königs Ludwigs I zu München* (1916), pp. 32-3 [31]; WOLTERS, *Illus. Kat.* (1912), p. 12 [31]; id. *Führer* (1928), p. 9 [31]; *Staatl. Sammlung* (1972), p. 36.

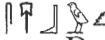
No. 44 [C 23]. SABU-KEM , Greatest of the Directors of craftsmen on the day of the festival, etc. Dyn. V.

MARIETTE, *Mastabas*, pp. 156-7, with plan of chapel.

False-door (fragments in Cairo Mus. JE 15046). Titles, id. ib. p. 157.

Statue of deceased as naked man, in Cairo Mus. CG 143. BORCHARDT, *Statuen*, i, Bl. 32, p. 105; HORNEMANN, *Types*, i, pl. 121.

No. 45 [C 21]. KAY  , King's *wac̄b*-priest, etc. Dyn. V-VI.





MARIETTE, *Mastabas*, p. 152.

False-door, unfinished, in Cairo Mus. JE 15045. Texts, id. ib. p. 152. Name and titles, DE ROUGÉ, *Inscr. hiéro.* pl. lxxxi [upper middle].

No. 46 [D 28]. SENEZEMIB , Prophet of Rē^c in the Sun-temples of Userkaf and Neferirkarē^c, Prophet of Neferirkarē^c and of the Pyramid of Neuserrē^c, etc. Temp. Neuserrē^c or later.

MARIETTE, *Mastabas*, pp. 258-9, with plan.

Doorway. Texts of drum and lintel, id. ib. p. 259; VASSALLI MSS. 11 [top].

No. 47 [E 3]. SABU   THETY  , Greatest of the Directors of craftsmen in the Two Houses on the day of the festival, etc. Temp. Pepy I or later.

MARIETTE, *Mastabas*, pp. 389-91, with plan of chapel on p. 391 [upper].

Lower part of right jambs of false-door, fragments, in Cairo Mus. CG 1709, 1756. Id. ib. fig. on p. 390; BORCHARDT, *Denkmäler*, ii, Bl. 100 (CG 1756), pp. 148, 177-8; autobiographical text, SETHE, *Urk.* i. 84-5 [6].

No. 48 [C 1 and H 14 (incorrectly)]. PTAḤSHEPSES , Greatest of the Directors of craftsmen in the Two Houses, Prophet of Rē̄c in the Sun-temples of Userkaf, Saḥurē̄c, Neferirkarē̄c, and Neuserrē̄c, etc. Temp. Neuserrē̄c.

Wife, Khaṣmaet , King's eldest daughter (probably of Userkaf).

MARIETTE, *Mastabas*, pp. 110-14, with plan on p. 111.

Lintel of doorway with offering-text, and false-door (top missing) with biographical text, offerings on sides, all in Brit. Mus. 682. *In situ*, DÜMICHEN, *Photo. Result.* ii; MILNE Photo. Album, 2. 12 [upper]. Brit. Mus. 682, *Hiero. Texts*, i², pl. xvii, p. 17; omitting offerings, ib. i, pls. 10 [32], 11-13 [32]; incomplete, BUDGE, *By Nile and Tigris*, ii, pl. facing p. 337; id. *The Mummy* (1925), pl. v facing p. 34. Some texts, DE ROUGÉ, *Inscr. hiéro.* pls. lxxix-lxxxii [top]. False-door, MARIETTE, *Mastabas*, pp. 112-13, 451-3, cf. 454; lower lintel, drum, and inner jambs, DÜMICHEN, *Resultate*, Taf. vi; parts of texts, DE ROUGÉ, *Recherches sur les monuments* [etc.] (1868), pp. 66-71 (repr. in *Bibl. Ég.* xxvi, pp. 64-9); biographical text, SETHE, *Urk.* i. 51-3 [32, A, B]. Names and titles, LIEBLEIN, *Dict.* No. 17. See *Guide, Eg. Collns.* (1964), p. 33.

No. 49 [C 10]. PTAḤSHEPSES , Judge and Inspector of book-keepers, Prophet of Ḥathor and Rē̄c, etc. Dyn. V.

MARIETTE, *Mastabas*, pp. 131-2, with plan.

Statues.¹ In Cairo Museum.

Deceased, three, CG 54, 77, 81, two seated, CG 28, 207, and scribe-statue, CG 83, all limestone. BORCHARDT, *Statuen*, i, Bl. 14, 17, 18, 7, 43, 19, pp. 47, 63, 65, 28-9, 139-40, 66-7. Texts of CG 54, 77, 81, 28, 207, MARIETTE, *op. cit.* p. 132 [5, 1, 3, 2, 4]. CG 28, head, PETRIE Gîza photo. 538; see MASPERO, *Guide*, p. 66 [143]. CG 83, WEIGALL, *Anc. Eg. . . . Art*, 34 [upper]; CAPART, *Memphis*, fig. 270; id. *L'Art ég.* ii, pl. 249; HORNE-MANN, *Types*, ii, pl. 409; SAMEH, *Daily Life*, fig. on p. 142.

Servant carrying sack and sandals, CG 111. BORCHARDT, *Statuen*, i, Bl. 24, pp. 86-7; id. in *Ä.Z.* xxxv (1897), fig. on p. 121 [left]; MARIETTE, *Album du Musée de Boulaq* (1872), pl. 20 [771]; PERROT and CHIPIEZ, *Hist. de l'Art*, i, figs. 47, 445; MASPERO, *Hist. anc.* i, fig. on p. 410; id. *Guide*, p. 75 [168] with fig. 23; DRIOTON and SVED, *Art ég.* fig. 29 [middle]; HORNE-MANN, *Types*, i, pl. 203; see BREASTED (Jr.), *Eg. Servant Statues*, pp. 57-8 [B, 1].

Man cleaning jar, CG 112. BORCHARDT, *Statuen*, i, Bl. 25, p. 87; PERROT and CHIPIEZ, *op. cit.* fig. 446; *Encycl. phot. Caire*, pl. 36; HORNE-MANN, *Types*, iii, pl. 655; SAMEH, *Daily Life*, fig. on p. 70; MICHALOWSKI, *Art*, fig. 225; DONADONI, *Egyptian Museum Cairo*, pl. on p. 49 [left]; *Great Museums*, fig. on p. 229 [4]. See MASPERO, *Guide*, p. 75 [170]; BREASTED (Jr.), *Eg. Servant Statues*, p. 46 [1].

No. 50 [C 9]. PTAḤSHEPSES , Greatest of the Directors of craftsmen in the Two Houses on the day of the festival, etc. Probably middle Dyn. V.

MARIETTE, *Mastabas*, pp. 129-30, with plan of chapel.

Lintel of doorway with offering-text (fragments in Aberdeen Mus. 1556). Text, id. ib. p. 130; VASSALLI MSS. 12 [middle], with sketch-plan. Aberdeen fragments, REID, *Illustrated Catalogue* [etc.] (1912), p. 194 with fig. on p. 195.



¹ It seems that the statues were also mentioned when Mariette was describing tomb D 54.



Two statues¹ of deceased seated, headless, in Cairo Mus. CG 93, 368. CG 93, BORCHARDT, *Statuen*, i, Bl. 21, p. 73; HORNEMANN, *Types*, iii, pl. 701. CG 368, see BORCHARDT, op. cit. pp. 193-4 (text); text, DE ROUGÉ, *Inscr. hiéro.* pl. vi [left].

No. 51 [C 22]. RĒ^cMERYPTAḤ , Inspector of singers to the flute, King's *wac*b-priest, etc. Dyn. V or later.

MARIETTE, *Mastabas*, pp. 152-6, with plan of chapel on p. 153 [upper].

False-door. Id. ib. figs. on pp. 154-5, cf. p. 153 [lower].



Statue-group, Washka , Overseer of young men, and wife 'Ankh-ḥas  seated, with small son Washka, in Cairo Mus. CG 100. BORCHARDT, *Statuen*, i, Bl. 22, pp. 78-9; MASPERO, *Égypte*, fig. 126; HORNEMANN, *Types*, v, pl. 1419. Text, MARIETTE, op. cit. p. 156; DE ROUGÉ, *Inscr. hiéro.* pl. xlviii [top].

No. 52 [D 26]. INY^cANKH  , Overseer of all craftsmen, etc. Late Dyn. V or later.

Father, Minnūfer , Overseer of the House of Weaving Women of the Residence. MARIETTE, *Mastabas*, pp. 254-5, with plan.



Remains of false-door. Name and titles, id. ib. p. 255 [middle].

Offering-basin, in Cairo Mus. CG 1336. BORCHARDT, *Denkmäler*, i, Bl. 6, p. 18; MARIETTE, op. cit. fig. on p. 255 [bottom]. Text, DE ROUGÉ, *Inscr. hiéro.* pl. iv [near bottom].

No. 53 [D 27]. 'ANKHMA^c  , Director of scribes of petitions, etc. Dyn. V-VI.

MARIETTE, *Mastabas*, pp. 256-8.

Lintel, panel, and drum with remains of jambs, all from false-door, in Cairo Mus. CG 1464-5, 1694. CG 1464-5, BORCHARDT, *Denkmäler*, i, Bl. 37, pp. 152-5. Texts (except linen-lists), MARIETTE, op. cit. pp. 256-8. Offering-list, HASSAN, *Giza*, vi [2], pls. xli-xlviii [54], p. 128. Linen-list left of panel, BRUGSCH, *Thes.* 1410 [top and middle]. CG 1694, BORCHARDT, op. cit. ii, Bl. 89, p. 139.

No. 54 [C 19]. SEKHEMKA   , Overseer of scribes of the land in the Two Houses, Director of scribes of the house of the master of the largesse, etc. End of Dyn. V or later.

Wife, Iti , Royal acquaintance.

MARIETTE, *Mastabas*, p. 150, with plan. Titles, DEVÉRIA squeezes, 6170B, 2.

False-door. Texts, MARIETTE, op. cit. p. 150.

Offering-basin of Peḥernūfer , Butcher of the slaughterhouse, etc., presumably from here, formerly in Amherst Colln., now in Copenhagen, Ny Carlsberg Glypt. Æ.I.N.1550. KOEFOED-PETERSEN, *Cat. des bas-reliefs*, pl. lxxxv [85], pp. 62, 76; FISCHER in *Orientalia*, n.s. 29 (1960), fig. 2, p. 169. Text, KOEFOED-PETERSEN, *Rec. inscr.* p. 75 [1550]; CRUM in GARDINER Notebook, 66, p. 14 [top]. See *Sotheby Sale Cat.* (AMHERST), June 13-17, 1921, No. 205 [2nd item] (called Nekht).

Statues. In Louvre.

See MARIETTE, *Sérapeum*, *Texte*, p. 11 with note 1; DE ROUGÉ, *Notice des monuments* (1883), pp. 48-9 [102-5], 50 [107]; CAPART in *J.E.A.* vii (1921), pp. 186-8.

¹ Possibly from tomb No. 48 [C 1].

Statue-group, deceased seated, with small figures of wife and son Kawehem  on sides, A 102 [N.116; E.3026]. BOREUX, *Guide*, i, pl. xxxii [left], pp. 243-4; MASPERO, *Sekhemka* [etc.] in RAYET, *Monuments de l'art antique*, i, Livraison IV, pl. xv; id. *Eg. Art*, pl. facing p. 56, cf. pp. 55-9; id. *Essais*, fig. 10, pp. 45-51; L. D. iii. 290 [13, 14]; PERROT and CHIPIEZ, *Hist. de l'Art*, i, fig. 89; SCHÄFER, *Äg. Kunst*, fig. on p. 24 [6]; RICHER, *Le Nu*, figs. 40, 42; *Encycl. phot. Louvre*, i, pls. 34-5; VANDIER, *Manuel*, iii, pl. xxxi [6], p. 573; SHOUKRY, *Privatgrabstatue*, Abb. 36; HORNEMANN, *Types*, v, pl. 1413; ARCHIVES phot. E.374; WILKINSON MSS. xxiv. 11 [middle left] (text), 38-9 (photos.). Wife and son, HEUZEY, *Histoire du costume. L'Orient*, pl. xix [1]. Wife, RIEFSTAHL, *Patterned Textiles in Pharaonic Egypt*, fig. 11. Text, CRUM in GARDINER Notebook, 67, p. 15 [upper]. See VANDIER, *Guide* (1948 and 1952), p. 9; (1973), p. 14.

Man, uninscribed, A 103 [N.115; E.3025]. *Encycl. phot. Louvre*, i, pl. 36 (called A 46); RICHER, *Le Nu*, fig. 38; VANDIER, *Manuel*, iii, pl. xlv [4], p. 573. Upper part, BOREUX, *Sculpture*, pl. x. See id. *Guide*, i, p. 241; VANDIER, *Guide* (1948 and 1952), p. 9; (1973), p. 14.

Deceased seated, dedicated by son Manüfer,¹ granite, A 104 [N.110; E.3021]. Id. *Manuel*, iii, pl. xlv [5], p. 573; ARCHIVES phot. E.537. See BOREUX, *Guide*, ii, p. 450; VANDIER, *Guide* (1973), p. 70 (as diorite).

Deceased seated, diorite, A 105 [N.111; E.3022]. Id. *Manuel*, iii, pl. xlvi [6], p. 573; REUTERSWÄRD, *Studien zur Polychromie der Plastik, i, Ägypten*, Taf. ii; MICHALOWSKI, *Art*, fig. 207. See BOREUX, *Guide*, ii, pp. 450-1; VANDIER, *Guide* (1948), p. 36 [middle]; (1952), pp. 36-7; (1973), p. 76 (as granite).

Peḥernüfer seated, A 107 [N.118]. BOREUX, *Guide*, i, pl. xxix [left], pp. 236-7; MASPERO, *Pehournowri* [etc.] in RAYET, *Monuments de l'art antique*, i, Livraison IV, pl. xiv; id. *Eg. Art*, pl. facing p. 80, cf. pp. 79-84; id. *Essais*, fig. 13, pp. 75-82; RICHER, *Le Nu*, fig. 43 [left] (called Hamset); VANDIER, *Manuel*, iii, pl. xlvi [4], p. 573; CRUM in GARDINER Notebook, 67, p. 14 (sketch); ARCHIVES phot. E.990. Upper part, BOREUX, *Sculpture*, pl. xii; GROUSSET, *The Civilizations of the East*, i, fig. 29. Text, FISCHER in *Orientalia*, n.s. 29 (1960), fig. 1, pp. 168-9; WILKINSON MSS. xxiv. 10 [bottom right], 11 [bottom left]; GARDINER Notebook, 58, p. 31. See VANDIER, *Guide* (1948), p. 9; (1952), pp. 9-10; (1973), p. 15.

No. 55 [D 25]. ZEFAU , Overseer of the Treasury, etc. Middle Dyn. V or later.

MARIETTE, *Mastabas*, pp. 251-4, with plan of chapel on p. 251 [upper]; PETRIE (H.) and MURRAY, *Seven Memphite Tomb Chapels*, pp. 13-14, 22 [97G], 23-4 [99], with plan of chapel,² etc., pl. xxiv.

Drum of doorway with name and title. Id. ib. pl. xi [bottom left].

False-door. Id. ib. pl. xiv; texts, MARIETTE, op. cit. pp. 251-4, 443 [H 5], cf. fig. on p. 252 [lower].

No. 56 [D 24]. NIMACETPTAḤ , Inspector of King's hairdressers, Supervisor of prophets (a) of Rēc in the Sun-temple of Neferirkarēc, (b) of the Pyramid of Neferirkarēc, etc. Temp. Neferirkarēc or later.

MARIETTE, *Mastabas*, p. 250, with plan.

Drum and lintel of doorway. Texts, id. ib. p. 250.

¹ Tomb, probably No. 26 [D 37].

² The position in PETRIE (H.) and MURRAY, *Seven Memphite Tomb Chapels*, pl. xxvii, is incorrect. The number of the tomb is misprinted as 59 in DE MORGAN, *Carte de la Nécropole Memphite*, 10.

No. 57 [D 23]. KAEMNEFERT , Prophet of Rē^c in the Sun-temples of Userkaf, Neferirkarē^c, and Neuserrē^c, Prophet of Khephren and Saḥurē^c, *wab*-priest of the Pyramids of Saḥurē^c and Neuserrē^c, etc. Temp. Neuserrē^c or later.

Plan XLVII.

MARIETTE, *Mastabas*, pp. 242-9, with plan of chapel on p. 242; L. E. R[OWE] in *Boston Mus. Bull.* viii (1910), pp. 19-20.

Chapel. Boston Mus. 07.1005 (lintel), 04.1761 (reliefs).

(1) Doorway. Lintel and drum with name and titles.

Texts, MARIETTE, *op. cit.* p. 243 [upper]; DE ROUGÉ, *Inscr. hiéro.* pl. lxxxvi [upper]. Lintel, GARDINER MSS. photo. 28.401 [lower]. View *in situ*, L. E. R[OWE], *op. cit.* fig. on p. 19 [upper].

(2) Deceased, and registers, **I-II**, lost, **III**, men binding bundles of flax, **IV**, reaping corn, **V**, transport of corn with donkeys, **VI**, bringing donkeys, **VII**, heaping corn, threshing with donkeys, and winnowing, **VIII**, chief of estate before scribes, and granaries, **IX-XI** (painted only), men bringing various articles and animals.

GARDINER MSS. photo. 28.398 [right]. Deceased, L. E. R[OWE], *op. cit.* fig. on p. 20. **III**, WRESZ., *Atlas*, iii. 55 [A]; 2nd man from right, SMITH, *Hist. Eg. Sculp.* fig. 199, p. 323; PIRENNE, *Hist. civ.* i, pl. 73 [lower] facing p. 220. Some texts, MARIETTE, *op. cit.* p. 246 [e].

(3) (much damaged) Deceased, and registers, **I-II**, scribes, **III-VII**, bringing animals, **VIII-X**, lost.

See *id. ib.* p. 245 [d] (some texts).

(4) Offerings.

(5) [1st ed. 4] False-door.

Id. ib. pp. 247-9. Lower part, GARDINER MSS. photo. 28.396-7, 399. Deceased at bottom, *Handbook* (1920), fig. on p. 34. Right jambs and some titles from left jambs, DE ROUGÉ, *Inscr. hiéro.* pl. lxxxvi [lower], lxxxvii [top and middle]. Name of the Sun-temple of Userkaf on right inner jamb, SMITH, *Country Life*, fig. 42.

(6) [1st ed. 5] Offering-list. MARIETTE, *op. cit.* pp. 244-5 [c].

(7) [1st ed. 6] Deceased fowling (with remains of original sketch), and five registers above, **I**, men bringing fish, **II**, pulling and carrying bundles of papyrus, **III**, two sub-registers, rope-making, **IV** and **V** (replaced by titles and two offering-bringers), making papyrus canoe and fishing with hand-nets, and three registers below, **VI-VIII** (painted only), men bringing various articles and animals.

DUNHAM in *A. J. A.* xxxix (1935), figs. 1-3, cf. 4-7, pp. 300-9. Birds, SMITH, *Country Life*, fig. 8; *id.* in *Boston Mus. Bull.* lxii (1964), fig. on p. 145. Deceased, and **I-V**, WRESZ., *Atlas*, iii. 41. **I-III**, L. E. R[OWE], *op. cit.* fig. on p. 19 [lower]; SMITH, *Country Life*, fig. 3; *id.* *Anc. Eg.* (1960), fig. 35, pp. 61, 63; *Handbook* (1920), fig. on p. 31; (1964), fig. on p. 183 [upper left]; (1976), fig. on p. 161 [upper left] (in last two called Sekhem^cankhptah); EK-SCHMITT, *Das Gedächtnis der Völker*, Abb. on p. 105 [upper]; SÉE, *Naissance*, fig. on p. 142. **II-III**, TERRACE in *The Connoisseur*, clxviii (1968), figs. 12, 13, p. 203. Man carrying bundle of papyrus in **II**, GHALIOUNGUI in *Bull. Inst. Ég.* xlv (1962-3), pl. ii, p. 41. **VII-VIII**, CAPART, *Memphis*, fig. 244. Offering-bringers with guiding lines in **VII**, SMITH, *Hist. Eg. Sculp.* fig. 95 [2], p. 247. See MARIETTE, *op. cit.* p. 244 [b].

(8) [1st ed. 7] Registers, **I-II** (now lost), bringing cattle and crossing canal, **III-IV**, boatmen jousting, **V**, herdsman tending cattle, including cow giving birth and bull mounting

cow, VI, netting fowl, VII, men bringing birds in cages, VIII, netting fish, IX, fowl, X, butchers, XI, bringing animals.

III-XI, GARDINER MSS. photo. 28.398 [left]. Some texts, MARIETTE, *op. cit.* pp. 243-4 [a].

Statues. In Cairo Museum. Probably from here.

Four, deceased seated, headless, and fragment, CG 61, 65, 66, 181, 377. See BORCHARDT, *Statuen*, i, pp. 53-4, 57, 125-6, 198-9 (texts); some texts of CG 61, DE ROUGÉ, *Inscr. hiéro.* pl. lii [bottom right].

No. 58 [E 6]. SNEFRUNŪFER [I]  †, Supervisor of prophets of the Pyramid of Zadkarē, Overseer of singers of the Great House, *warb*-priest of the Pyramid of Menkauhor. End of Dyn. V or Dyn. VI. A of de Morgan.

MARIETTE, *Mastabas*, pp. 394-5, with plan of chapel.

Walls. Deceased at table, with sons (including possibly Snefrunūfer [II], tomb No. 59 [E 7]), offering-bringers and butchers. Texts, *id. ib.* pp. 394-5; names of two sons, DE ROUGÉ, *Inscr. hiéro.* pl. lxxxviii [lower middle].

False-door, in Cairo Mus. JE 15050. Parts of text, *id. ib.* pl. lxxxviii [upper middle and bottom]; titles, MARIETTE, *op. cit.* p. 395 [bottom].

No. 59 [E 7]. SNEFRUNŪFER [II]  †, Supervisor of prophets of the Pyramid of Zadkarē, Overseer of singers of the Great House, etc. End of Dyn. V or later. B of de Morgan.

Father (possibly), Snefrunūfer [I] (tomb No. 58 [E 6]).

MARIETTE, *Mastabas*, pp. 396-8.

Lintel with offering-text, in Cairo Mus. CG 1421. BORCHARDT, *Denkmäler*, i, Bl. 22, p. 102; DEVÉRIA squeezes, 6170A, 4; part of text, DE ROUGÉ, *Inscr. hiéro.* pl. iii [lower middle]; SETHE, *Urk.* i. 178 [21 (112), D].

False-door, in Cairo Mus., upper lintel and panel, CG 1420, 1436, lower lintel and drum and parts of jambs, CG 1461. CG 1420, 1436, BORCHARDT, *op. cit.* Bl. 22, 31, pp. 101, 119-20; DEVÉRIA squeezes, 6170A, 10, 12; texts, MARIETTE, *op. cit.* p. 397. CG 1461, text, BORCHARDT, *op. cit.* pp. 149-50; DE ROUGÉ, *Inscr. hiéro.* pl. iv [lower middle]; titles on lintel, MARIETTE, *op. cit.* p. 398 [top]; address, on jambs, SETHE, *Urk.* i. 58 [40] (copy by Erman).

Offering-table, alabaster, in Cairo Mus. CG 1328. BORCHARDT, *op. cit.* Bl. 4, pp. 12-13; MARIETTE, *op. cit.* p. 396; DEVÉRIA squeezes, 6170A, 21; part of text, BRUGSCH, *Thes.* 1230 [upper middle]; two titles, DE ROUGÉ, *op. cit.* pl. iii [bottom]; see MASPERO, *Guide*, p. 62 [137].

No. 60 [D 22]. TY \Rightarrow , Overseer of the Pyramids of Neferirkarē and Neuserre, and of the Sun-temples of Saḥurē, Neferirkarē, Raṅneferēf, and Neuserre, etc. Temp. Neuserre to end of Dyn. V.

Plan XLVIII.

Wife, Neferhetpes , Prophetess of Neith North of the Wall and of Ḥaḥor Mistress of the Sycamore, etc.

Selected references for frequently reproduced scenes.

STEINDORFF, *Das Grab des Ti; Le Tombeau de Ti*, i by ÉPRON and DAUMAS (hereafter ÉPRON), ii, iii by WILD (hereafter WILD, ii, iii), iv by WILD in preparation. Plans, STEINDORFF, Bl. 1, 2; ÉPRON, pl. i; DÜMICHEN, *Resultate*, Taf. i; MARIETTE, *Mastabas*, figs. on pp. 331-4; BRUGSCH, *Die ägyptische Gräberwelt* (1868), Taf. vi [172]. Views, mainly showing Pillared Hall, DÜMICHEN, *Photo. Result.* iv; BÉCHARD and PALMIERI, *L'Égypte et la Nubie* (1887), pl. li (reversed); EBERS, *Aegypten*, i, fig. on p. 183; Eng. ed. fig. on p. 160; HICHENS, *Egypt and its Monuments*, pl. facing p. 35; JÉQUIER, *L'Architecture*, i, pl. 5 [1]; SCHÄFER and ANDRAE, *Kunst* (1925), 213; (1930 and 1942), 221; VON BISSING, *Äg. Kunstgeschichte*, Taf. xxxiii [256], *Text*, i, p. 69; HAMANN, *Äg. Kunst*, Abb. 142; ÉPRON, pl. ii [right]. Texts, ČERNÝ Notebook, 120, pp. 2-55. Collation of Steindorff's texts, GUNN Notebooks, 4, 5. Squeezes in Boston Museum, see DUNHAM in *J.A.O.S.* 56 (1936), p. 173. Hieroglyphic signs, MARIETTE, *Mastabas*, p. 241; MURRAY, *Saqqara Mastabas*, ii, pls. vi, vii, pp. 27-9 [29]. Some names, titles, and texts, DÜMICHEN, *Resultate*, Taf. iii [1-8]; BRUGSCH, *Die ägyptische Gräberwelt* (1868), Taf. i-v [1-169]; id. *Thes.* 1467-8 [139 a-p], 1470 [u]. Names, DE ROUGÉ, *Recherches sur les monuments* [etc.] (1866), pp. 93-7 (repr. in *Bibl. Ég.* xxvi, pp. 89-93); LIEBLEIN, *Dict.* No. 26, *Suppl.* p. 934. Name of sun-temple, WRESZ., *Atlas*, iii, Textabb. 58, I on p. 115.

I. Portico.

(1) (a) [1st ed. 1] Registers, I, [people before deceased seated], II-IV, estates. (b) At bottom, remains of estates. (c) [1st ed. 2] Deceased, with sons Ty and Demez  behind, and registers, I-III, tending animals, IV-V, poultry-yard. (d) [1st ed. 3] [Deceased, with son], and three registers of fishing, including fishing with baskets, and bringing fish. (e) [1st ed. 6] Address, and deceased. (f) [1st ed. 7] Remains of text, and [deceased].

(a) STEINDORFF, Taf. 3 [upper]; ÉPRON, pls. iv, v; DÜMICHEN, *Photo. Result.* v. 4th to 11th estates in II-III, MASPERO, *Hist. anc.* i, fig. on p. 254. Names of estates, JACQUET-GORDON, *Domaines*, pp. 357-60 [1785], Nos. 1-36, cf. figs. 138, 139 [a].

(b) STEINDORFF, Taf. 3 [lower]; ÉPRON, pl. x [3]. Names, JACQUET-GORDON, op. cit. pp. 357, 360-1 [1785], Nos. 37-72, cf. figs. 138, 139 [b].

(c) STEINDORFF, Taf. 4-6; ÉPRON, pls. vi-viii. Incomplete, REIL, *Wanderungen durch die Gräber des alten Reiches in Saccara in Westermann's Jahrbuch der Illustrierten Deutschen Monatsheften* (1878), vol. 43, p. 412. IV, 3rd and 4th scenes, PRISSE, *L'Art ég.* ii, *Sculpture*, 11th pl. [lower] 'Troupeaux de grues' [etc.], *Texte*, pp. 398-9; AMÉLINEAU, *Hist. sépulture*, ii, pl. xxxix [2nd row].

(d) STEINDORFF, Taf. 7; ÉPRON, pls. ix, x [1].

(e) STEINDORFF, Taf. 8; ÉPRON, pl. xi. Text, SETHE, *Urk.* i. 173-4 [19 (110), A]; WILD in *B.I.F.A.O.* lviii (1959), pp. 104-5, cf. 101-3, 106-13; EDEL in *Mitt. Kairo*, 13 (1944), pp. 59-61, 66-7, cf. 56-68; GARDINER MSS. 29.61 (1) (collated by Gunn); part, SAINTE FARE GARNOT, *L'Appel aux vivants*, pp. 5-6, cf. 7-11.

(f) STEINDORFF, Taf. 9; ÉPRON, pl. x [2]. Text, SETHE, *Urk.* i. 174 [19 (110), B]; GARDINER MSS. 29.61 (2) (copy by Gunn).

(2) and (3) [1st ed. 4, 5] Pillars. Deceased, with titles above.

STEINDORFF, Taf. 2; ÉPRON, pls. ii [left], iii; DÜMICHEN, *Photo. Result.* iii; JÉQUIER, *L'Architecture*, i, pl. 5 [2]; CAPART, *Memphis*, fig. 301. (2) ABBATE, *Arte egizia*, fig. 25; *Capolavori*, i, No. 10 (1963), fig. on p. 162 [lower right]; Eng. ed. fig. on p. 154 [lower right]. (3) *The Egyptian Education Bureau London. The Bulletin*, No. 58 (Sept. 1951), fig. on p. 16 [upper right].

II. Pillared Hall.

(4) [1st ed. 8, 9] Between deceased and Ka'aper $\text{𓆎} \text{𓆏} \text{𓆑}$, Overseer of *ka*-servants, etc., on left, and deceased and wife (lower parts only) on right, registers, **I** (lost) [offering-bringers] on left, **II**, two boats with statues (one now lost), **III**, overthrowing ox, and two groups of butchers.

Omitting deceased and wife, BÉCHARD and PALMIERI, *L'Égypte et la Nubie* (1887), pl. lii (reversed). Omitting deceased and wife and one group of butchers, GRIFFITH INST. photo. 315A (SEBAH, 180). Without one boat, STEINDORFF, Taf. 12-14 [except lower right]; ÉPRON, pls. xiii-xv [upper]; with boat reconstructed, JUNKER, *Gîsa*, xi, Abb. 88a (after STEINDORFF). Overthrowing ox, and one group of butchers in **III**, PERROT and CHPIEZ, *Hist. de l'Art*, i, fig. 125; overthrowing ox, DÜMICHEN, *Photo. Result.* vi. Texts relating to statues, WILD in *Mélanges Mariette*, pp. 181, 183.

(5) [1st ed. 10] On either side of aperture of serdab, offering-bringers.

STEINDORFF, Taf. 14 [lower right], 15 [upper]; ÉPRON, pl. xv [lower].

(6)-(7) [1st ed. 11, 12] (from left) Two registers, deceased carried in palanquin, with dwarf leading monkey and dog below, and deceased seated, and wife squatting (block now replaced), with [scribes writing and men], and Ka'aper and sons squatting, and attendants.

Without block with deceased and wife, STEINDORFF, Taf. 15 [lower], 16, 17; ÉPRON, pls. xvi, xvii, xviii [lower]. Ka'aper and sons, BRUGSCH, *Thes.* 1469 [t]. Men carrying chairs, WRESZ., *Atlas*, iii. 87 [A, B].

(8) [1st ed. 13] False-door of son Demez.

STEINDORFF, Taf. 18, 19; ÉPRON, pls. xviii [upper left], xix [upper left], xx.

(9) [1st ed. 14, 15] Deceased followed by officials, and **I-III** (left part of **I-II** lost), boats, each with sub-register of fowl, wild animals, or men tending cattle.

STEINDORFF, Taf. 20-2; ÉPRON, pls. xix [upper right], xxi-xxvi. **I-III**, WRESZ., *Atlas*, iii. 109 [B]. Two boats from **II** and **III** and pigeons and addaxes, MONTET, *Scènes*, fig. 27 on p. 134. Boat in **II** and fowl and animals below, DÜMICHEN, *Resultate*, Taf. iii [E]. Pigeons from **II**, LAUER, *Saqqara*, pl. 16. Two addaxes in **III**, CAPART, *Memphis*, fig. 237.

(10) [1st ed. 16, 17, part 18] Deceased, with wife squatting and two sons, and registers, **I-III**, officials, scribes, and poultry-yard.

STEINDORFF, Taf. 23, 24 [left]; ÉPRON, pls. xviii [upper right], xix [lower left], xxvii-xxx, xxxii [left]. **I-III** and poultry-yard, WRESZ., *Atlas*, iii. 82; MONTET, *Scènes*, pl. x facing p. 120, fig. 25, pp. 116-21. **II-III** and poultry-yard, AMÉLINEAU, *Hist. sépulture*, ii, pl. xxxix [3rd row]. Officials and scribes, MARIETTE, *Voyage*, i, pl. 10, p. 40. Two men with baskets, PIRENNE, *Hist. civ.* i, pl. 78 facing p. 249. Poultry-yard, REIL, op. cit. p. 413. Text in front of deceased, BRUGSCH, *Thes.* 1470 [w].

(11) [1st ed. 18, 19] Deceased with wife and two sons, and registers (each divided into two sub-registers), **I-II**, feeding geese, **III**, feeding cranes.

STEINDORFF, Taf. 24 [right], 25 [left]; ÉPRON, pls. xix [lower middle], xxxi, xxxii [right], xxxiii-xxxv [upper]. **I-III**, WRESZ., *Atlas*, iii. 83 [A]. **II-III**, MARIETTE, *Voyage*, i, pl. 9, pp. 38-40. **III**, group of cranes on right, SPIEGEL, *Hochkultur*, Taf. 57 [lower]; on left, MONTET, *Scènes*, pl. xi [2].

(12) [1st ed. 20] Deceased and wife (upper parts destroyed) with [son].

STEINDORFF, Taf. 25 [right]; ÉPRON, pls. xix [lower right], xxxv [lower].

(13), (14) [1st ed. 21-2], (15), (16) Pillars. Deceased.

Omitting (15), ÉPRON, pl. xii. (13) and (14) STEINDORFF, Taf. 11.

III. First Corridor.

- (17) [1st ed. 23-4] (a) and (b) Three figures of deceased, with titles.
STEINDORFF, Taf. 26-7; ÉPRON, pls. xxxvi, xxxvii.
- (18)-(19) [1st ed. 25-6] Six registers of offering-bringers.
STEINDORFF, Taf. 28-39; ÉPRON, pls. xli-xliii.
- (20) [1st. ed. 27] Four remaining registers of offering-bringers.
STEINDORFF, Taf. 53-4; ÉPRON, pl. xl.
- (21) [1st ed. 28] False-door of wife.
STEINDORFF, Taf. 45-52; ÉPRON, pl. xxxix. Panel, AMÉLINEAU, *Hist. sépulture*, ii, pl. xliii [top row right].
- (22) [1st ed. 29] Six registers of offering-bringers.
STEINDORFF, Taf. 40-4; ÉPRON, pl. xxxviii.

IV. Second Corridor.

(23) [1st ed. 30-2] Doorway. (a) Above doorway, deceased seated receives report from steward, with two registers of sons and officials below, and two registers with an offering-bringer in each on left jamb. (b) and (c) Two figures of deceased with sons Demez and Ty. (d) Above doorway, deceased with family pulling papyrus from canoe.

(a) STEINDORFF, Taf. 55-7; ÉPRON, pl. xliv.

(b) and (c) ÉPRON, pl. xlv. Deceased and son Demez at (b), AMÉLINEAU, *Hist. sépulture*, ii, pl. xl [middle right].

(d) STEINDORFF, Taf. 58; ÉPRON, pl. xlvi; CAPART, *Memphis*, fig. 356; WRESZ., *Atlas*, iii. 43; MONTET in *Kémi*, xiv (1957), fig. 1, p. 102 note 2; EKSCHMITT, *Das Gedächtnis der Völker*, Abb. on p. 105 [lower].

(24) [1st ed. 33] Four registers, **I, 1, 2**, men dragging statue on sledge, with two sub-registers of offerings, **II, 1, 2**, dragging seated statue, **III, 1, 2**, dragging statue, with men carrying vases and offering-stand behind **2**, and sub-registers of offerings, **IV, 1-4**, butchers.

STEINDORFF, Taf. 62-73; ÉPRON, pls. l-iv. **III**, MONTET, *Scènes*, figs. 47-8 on pp. 387-8. **III, 2** and **IV** (almost complete), HAMANN, *Äg. Kunst*, Abb. 146. **IV, 1**, BERGER, *Altägyptische Wandmalerei*, Abb. 4; MICHALOWSKI, *Art*, fig. 242; **2**, EGGBRECHT, *Schlachtungsbräuche im Alten Ägypten* [etc.], Taf. iii [B], pp. 199-201; **3**, MONTET, op. cit. fig. 29 on p. 165.

(25) [1st ed. 34] Above doorway, deceased seated, with wife squatting, text concerning statues (relating to (24)), and registers, **I**, musicians, **II-III**, female dancers and clappers. Jamb, texts relating to (24) and (26)-(27). Thicknesses of doorway, see (33).

STEINDORFF, Taf. 59-61; ÉPRON, pls. lvi, lvii. Text concerning statues before deceased, WILD in *Mélanges Mariette*, p. 184. **I-III**, MASPERO, *Hist. anc.* i, fig. on p. 279 (registers not in order); WRESZ., *Atlas*, iii. 30; REIL, op. cit. pp. 412-13; vol. 44, p. 621; WOLF, *Kunst*, Abb. 200; BRUNNER-TRAUT, *Der Tanz im alten Ägypten*, Abb. 3. **I**, HICKMANN, *45 Siècles*, pls. xvi [B], cvii [C]; id. in *Bull. Inst. Ég.* xxxiv (1951-2), fig. 10, p. 243; id. *Musicologie pharaonique*, fig. 10, p. 111; two singers and harpist, id. *Ägypten*, Abb. 53, 91; two singers, id. in *Orientalische Musik*, Taf. i [1]. Dancers in **III**, WOLDERING, *Götter*, fig. on p. 234 [Kat. 58] (reversed). Text on left jamb, WILD, op. cit. p. 183 [bottom]; on right jamb, BRUGSCH, *Thes.* 1468 [q].

(26)-(27) [1st ed. 35-6] Registers, **I**, [boat-building], **II-III**, three rowing-boats in each, **IV**, three sailing-boats, **V** (on either side of doorway), sailing-boat.

STEINDORFF, Taf. 74-81; ÉPRON, pls. xlvi-xlix. Boats on left in **II-III**, SCHÄFER and ANDRAE, *Kunst* (1925), 251; (1930 and 1942), 263. Four boats on left in **II-III**, and **V**,

DÜMICHEN, *Resultate*, Taf. iii [A-D], iv, v. Middle boats in **II** and **III**, KÖSTER, *Das antike Seewesen*, Taf. 6 between pp. 32-3; LANDSTRÖM, *Ships of the Pharaohs*, figs. 154, 163; in **III** and **IV**, RANKE, *The Art of Ancient Egypt*, and BREASTED, *Geschichte Aegyptens* (1936), 207-8; GALASSI in *Critica d'Arte*, n.s. ii (1955), figs. 257-8, p. 313. Middle boat in **IV**, WOLF, *Kunst*, Abb. 199; WRESZ., *Atlas*, iii. 110; CAPART, *Pour faire aimer l'art égyptien*, fig. 58. Boat on left in **V**, KÖSTER, op. cit. Taf. 2 facing p. 16; on right, SAINTE FARE GARNOT in *L'Amour de l'Art*, xxviii, fig. on p. 237; MONTET, *Scènes*, fig. 45 on p. 347.

V. Store-room.

(28) [1st ed. 37-8] Doorway. (a) and (b) Deceased.

STEINDORFF, Taf. 82; ÉPRON, pl. lviii [upper].

(29) [1st ed. 39-40] Above, and left of doorway, vases.

STEINDORFF, Taf. 87; ÉPRON, pl. lix. Some vases, PRISSE, *L'Art ég.* ii, *Art Industriel*, 72nd pl. [8, 9, 11-18] 'Choix de vases contemporains des pyramides', *Texte*, p. 430. Inscribed vases, MARIETTE, *Mastabas*, figs. on pp. 237-8.

(30) [1st ed. 41-2] and (31) [1st ed. 44-5] Deceased, with wife squatting, and two children, attendants behind, and offerings and four registers of offering-bringers.

(30) STEINDORFF, Taf. 94-104; ÉPRON, pls. lx-lxii. (31) STEINDORFF, Taf. 88-93; ÉPRON, pls. lxiii-lxv; deceased and family, KARNAGHAN in *Art and Archaeology*, xxxi [5] (May 1931), fig. on p. 259 [upper] (copy by J. L. Smith); part of first three registers of offering-bringers, MONTET, *Scènes*, pl. xxiv [1]; four offering-bringers in bottom register, MACKENZIE, *Egyptian Myth and Legend*, pl. facing p. 106.

(32) [1st ed. 43] Seven registers of pottery-making, baking and brewing, with scribes recording in bottom register.

STEINDORFF, Taf. 83-6; ÉPRON, pls. lxvi-lxxi; WRESZ., *Atlas*, iii. 70. **I-VI**, MONTET, *Scènes*, pls. xix, xx. **II-IV**, WILD in *B.I.F.A.O.* lxiv (1966), pl. ix (from WRESZ.), pp. 95-8, 113-15. **II-IV, VI**, LORET, *La Tombe d'un ancien Égyptien* in *Annales du Musée Guimet*, x (1886), pl. xxi [left, 2nd to 5th rows]. Two brewers in **II**, PRISSE, *L'Art ég.* ii, *Art Industriel*, 72nd pl. [22-7] 'Choix de vases contemporains des pyramides', *Texte*, p. 430. **V-VII**, CAPART, *Memphis*, fig. 367. **VII**, BRUGSCH, *Thes.* 1469 [r, s]; two scribes and book-keeper, SAMEH, *Daily Life*, fig. on p. 139 (as Mereruka); HUSSEIN, *Vom Papyrus zum Codex*, pl. on p. 35.

VI. Inner Hall. View, HAMANN, *Ag. Kunst*, Abb. 143.

(33) Doorway. (a) and (b) Deceased. Outer jambs and scenes above doorway, see (25).

ÉPRON, pl. lviii [lower].

(34) [1st ed. 46-7] Deceased seated, with wife squatting, and registers, **I-II**, flax-harvest, **III-V**, reaping corn, **VI, 1**, bringing donkeys, **2**, tying up sack with sheaves, **VII, 1** and **3**, transport of corn with donkeys, **2**, loading donkey, **4**, stubborn donkey, **VIII, 1** and **2**, piling up sheaves, **3**, emptying sack, **IX, 1**, officials, and threshing with **2**, donkeys, **3**, cattle, **X, 1**, attendants, **2** and **3**, filling granaries, **4**, winnowing.

STEINDORFF, Taf. 121-5; WILD, iii, pls. cxxxvi-cxxxix, cxlix-clv. Deceased and wife, PRISSE, *L'Art ég.* ii, *Peinture*, 46th pl. 'Groupe Iconique' [etc.], *Texte*, p. 419; with **IX, 1**, CAPART, *Memphis*, fig. 359. **I-VIII**, WRESZ., *Atlas*, iii. 48-9. **IV-VIII**, CAPART, *L'Art ég.* iii, pl. 446. **IV-X**, DÜMICHEN, *Photo. Result.* x. Flutist and singer in **IV**, HICKMANN, *45 Siècles*, pl. cxii [B]. Flutist, singer, and three reapers, in **IV-V**, CAPART, *Memphis*, fig. 361; and five reapers, MONTET, *Scènes*, pl. xvi. **V-VIII**, POULSEN (F.), *Aegyptens Kunst*

(1933), fig. 42. Singer in **V**, TZARA and SVED, *L'Égypte face à face*, fig. on p. 84. Right part of **V** and **VI**, **1**, GALASSI in *Critica d'Arte*, n.s. ii (1955), fig. 256, p. 313. **VI-X**, BAIKIE, *A History of Egypt*, i, pl. xi [lower]; GRIFFITH INST. photo. 315B (SEBAH, 179). **VI-VII**, MONTET, *Scènes*, pl. xvii. Right part of **VI-IX**, PEET in HAMMERTON, *Universal History of the World*, i, fig. on p. 487 [lower]. **VI**, **1** and **VII**, **2**, **3**, **4**, CAPART, *Paysage*, figs. 37-8; id. *Memphis*, figs. 362, 364. **VI**, **1**, **VII**, **3**, **4**, **VIII**, **2**, **3**, **IX**, **2**, **X**, **2**, RANKE, *The Art of Ancient Egypt*, and BREASTED, *Geschichte Aegyptens* (1936), 191, 196-7, 212-13. **VI**, **1** and **VII**, **1**, PERROT and CHIPIEZ, *Hist. de l'Art*, i, figs. 456-7. **VI**, **2** and **VII**, **4**, CAPART in GLANVILLE, *The Legacy of Egypt*, pl. 4 [5]. **VII-X** (omitting right end of **IX-X**), GARDINER MSS. photo. 28.1059 (from Quibell). **VII**, **1-3**, STUART, *Nile Gleanings*, pl. iv [upper] facing p. 62. **VII**, **1** and **2**, MICHALOWSKI, *Art*, fig. 241. **VII**, **1**, POSENER, SAUNERON and YOYOTTE, *Dict. civ.* fig. on p. 13 [upper]. **VII**, **3**, **4**, ROSS, *The Art of Egypt*, pl. on p. 115 [top]. **VII**, **3**, **4**, **VIII**, **2**, **IX**, **1**, **2**, WEIGALL, *Anc. Eg. . . . Art*, 50 [middle and bottom], 51 [middle lower]. **VII**, **3**, **4**, **VIII**, **2**, **3**, **IX**, **2**, **X**, **2**, BALODIS, *Ägypten. Pyramidernes og mysteriernes land*, fig. 11. Three men, from **VIII**, **1** and **2**, SAMEH, *Daily Life*, fig. on p. 35. **VIII-X**, MONTET, *Scènes*, pl. xviii, fig. 33; WRESZ., *Atlas*, iii. 50. **VIII**, **3**, MARIETTE, *Mastabas*, figs. on pp. 239-40. **IX**, **2** or part, PIJOÁN, *Summa Artis*, iii (1945), fig. 206; GALASSI in *Critica d'Arte*, n.s. ii (1955), fig. 260 on p. 329 [bottom], cf. p. 313; GIOSEFFI in ib. n.s. xviii (1971), fig. 3a, p. 8; LANGE and HIRMER, *Ägypten. Architektur* (1955 and 1957), pl. 70 [upper]; (1967), pl. 68 [upper]; MICHALOWSKI, *Art*, fig. 246; SAMEH, op. cit. fig. on pp. 36-7 [left]; ABBATE, *Arte egizia*, fig. 27. **IX**, **2** and **X**, **3**, **4**, CAPART, *Memphis*, fig. 365. Parts of **IX**, **2** and **X**, **3**, LANGE, *Äg. Kunst*, pl. 34. **IX**, **3**, EBERS, *Ägypten*, i, fig. on p. 187 [middle]; Eng. ed. fig. on p. 163 [middle].

(35) [1st ed. 48] Upper part, remains of scene with lion seizing gazelle, and hare in desert. Lower part, registers, **I**, [bringing sheep], **II-IV**, building boats.

Upper part. WILD, ii, pls. xcvi [A], cxxvii; SCHWEITZER, *Löwe und Sphinx im alten Ägypten*, Abb. 6, pp. 53-4.

Lower part. STEINDORFF, Taf. 119-20; WILD, ii, pls. xcvi [B], xcvi, xcvi, cxxviii, cxxix; DÜMICHEN, *Photo. Result.* xi; WOLF, *Kunst*, Abb. 196; WRESZ., *Atlas*, iii. 36, 86 [B]; GARDINER MSS. photos. 28.1060-1 (from Quibell). Left part of **II-III**, BASS, *A History of Seafaring*, fig. 21 on p. 31; of **II-IV**, MICHALOWSKI, *Art*, fig. 18. Workmen in **II**, WOLDERING, *Götter*, Abb. 31. **III-IV**, MEYER, *Geschichte des alten Ägyptens*, ii, fig. on p. 117; LANDSTRÖM, *Ships of the Pharaohs*, fig. 102. Group on right in **III**, EBERS, *Ägypten*, i, fig. on p. 186 [lower]; Eng. ed. fig. on p. 162 [lower]. Right part of **III-IV**, DE MONTGON, *L'Égypte*, fig. on p. 73; PEET in HAMMERTON, *Universal History of the World*, i, fig. on p. 501; CAPART, *Memphis*, fig. 197; CLARKE and ENGELBACH, *Ancient Egyptian Masonry*, fig. 38; MONTET, *Scènes*, pl. xxiii; RANKE, *The Art of Ancient Egypt*, and BREASTED, *Geschichte Aegyptens* (1936), 206; BYVANCK, *De Kunst*, pl. xxi [78]; CHAMPDOR, *L'Égypte des Pharaons*, pl. on p. 32; PIRENNE, *Hist. civ.* i, pl. 72 [upper] facing p. 213; DE RACHEWILTZ, *Vita nell'antico Egitto*, Tav. xv. **IV**, some workmen, SAMEH, *Daily Life*, figs. on pp. 44, 52; workmen on right, POSENER, SAUNERON and YOYOTTE, *Dict. civ.* fig. on p. 36; ROSS, *The Art of Egypt*, pl. on p. 115 [bottom]. Boat in **IV**, KÖSTER, *Das antike Seewesen*, Taf. 3 facing p. 17.

(36) [1st ed. 49] Upper part, deceased with wife and small son, and remains of registers, **I-II**, catching pigeons, **III-VI**, vintage. Lower part, deceased seated, with wife squatting, and registers, **I** (left part lost), metal-workers, **II** (left part lost), sculptors and vase-makers, **III**, carpenters, **IV**, officials, aperture of serdab with man censuring on either side, men bending poles, leather-workers, seal-maker and market-scenes.

STEINDORFF, Taf. 130-4; WILD, iii, pls. clxx-clxxiv, details, pls. cxxxiii, cxlv [B], cxlvi, cxlvii.

Upper part. Deceased and family, PERROT and CHIPIEZ, *Hist. de l'Art*, i, fig. 57; RANKE, *Meisterwerke*, Abb. 59b; SMITH (J. L.), *Tombs, Temples, and Ancient Art*, pl. facing p. 65 (painting). **III-VI**, MONTET, *Scènes*, pl. xxi.

Lower part. WRESZ., *Atlas*, iii, 35; GARDINER MSS. photos. 28.1062-4 (from Quibell). Deceased with wife and **II-IV**, WOLF, *Kunst*, Abb. 197-8. **I-II**, id. *Die Stellung der ägyptischen Kunst* [etc.], Taf. vi. **I-IV**, MONTET, *Scènes*, pl. xxii. Right group in **I**, CAPART, *Memphis*, fig. 345. **II-III**, RANKE, *The Art of Ancient Egypt*, and BREASTED, *Geschichte Aegyptens* (1936), 209. Sculptors in **II**, VANDIER, *Manuel*, iii, fig. 2 facing p. 12, cf. p. 8; making standing statues, WOLDERING, *Götter*, fig. on p. 233 [Kat. 56] (reversed); group on left, DAUMAS, *Civ. de l'Ég.* pl. 79; TZARA and SVED, *L'Égypte face à face*, pl. on p. 62. Right half of **III-IV**, SCHÄFER and ANDRAE, *Kunst* (1925), 248; (1930 and 1942), 260. Right half of **III**, RAGAI, *L'Art*, pl. 10 [23]. **III**, standing man sawing and two others, LANGE, *Lebensbilder*, Abb. 8; PRITCHARD, *Anc. Near East*, fig. 123; WOLDERING, *Götter*, fig. on p. 233 [Kat. 55]; kneeling man sawing, LANGE, *Äg. Kunst*, pl. 36; WOLF, *Die Stellung der ägyptischen Kunst* [etc.], Taf. i [a]; two men making bed, DAUMAS, *Civ. de l'Ég.* pl. 77; with man drilling, HAMANN, *Äg. Kunst*, Abb. 30; SAMEH, *Daily Life*, fig. on p. 53 [lower]; GOYON (G.) in *Jaarbericht Ex Oriente Lux*, No. 21 (1970), pl. xxii, p. 156; man drilling, TZARA and SVED, *L'Égypte face à face*, pl. on p. 56. Right half of **III-IV**, POULSEN (F.), *Ägyptens Kunst* (1933), fig. 43. **IV**, men censing, MORET, *Le Nil*, pl. v [2]; bending poles, and leather-worker, MONTET, *Scènes*, fig. 41 on p. 312; text of leather-worker, JUNKER, *Weta und das Lederkunsth Handwerk* [etc.] in *Sitzungsb. Wien*, 231 [1] (1957), Taf. i [b, left], Abb. 5, pp. 20-3; seal-maker, NEWBERRY in *P.S.B.A.* xxvii (1905), pl. facing p. 286; some texts, ČERNÝ Notebook, 118, p. 95 verso [top].

(37) [1st ed. 50] Deceased leaning on staff, with wife squatting, and registers **I-X**, men bringing animals and fowl, with chiefs rendering accounts and two sub-registers of scribes in **VII**.

STEINDORFF, Taf. 128-9; WILD, iii, pls. clxiv-clxix, details, pls. cxxxiv, cxlii-cxlv [A]. Omitting deceased, GARDINER MSS. photos 28.1065-7 (from Quibell). Deceased and wife, CAPART, *L'Art ég.* iii, pl. 445; LANGE and HIRMER, *Aegypten. Architektur* (1955 and 1957), pl. 69; (1967), pl. 67; PIRENNE, *Hist. civ.* i, pl. 84 facing p. 261; GROENEWEGEN-FRANKFORT and ASHMOLE, *Art of the Ancient World*, fig. 36. Deceased and wife, two herdsmen in **V**, and **VI-X**, CAPART, *Memphis*, figs. 222, 267, 360, 369-70. Deceased and wife and part of **III-X**, ELISOFON, *The Nile*, pl. 252; DÜMICHEN, *Photo. Result.* vii, viii. Man with oryx on right in **II**, PIRENNE, *Hist. civ.* i, pl. 82 between pp. 260-1. **III-VI**, MONTET, *Scènes*, pl. xii. Deceased and wife, and **V-X**, ASSELBERGHS, *Beeldende Kunst in Oud-Egypte*, fig. 16. **VII**, chiefs and scribes, BREASTED in *A. J. S. L.* xxxii (July 1916), fig. 3 on p. 234; EBERS, *Aegypten*, i, fig. on p. 186 [upper]; Eng. ed. fig. on p. 162 [upper]; chiefs, MEYER, *Geschichte des alten Aegyptens*, ii, fig. on p. 67; scribes, MONTET, *Scènes*, pl. xiii [1]. Middle part of **VIII**, DAUMAS, *Civ. de l'Ég.* pl. 67. Man with bullocks on left in **IX**, CAPART, *Documents*, i, pl. 21; one bullock, HAMANN, *Äg. Kunst*, Abb. 156. Bullock in **IX**, and ducks, geese, and cranes in **X**, MURRAY, *Saqqara Mastabas*, ii, pl. iv [12, 13], v [6-9], pp. 26-7. Cranes in **X**, PRISSE, *L'Art ég.* ii, *Sculpture*, 11th pl. [upper] 'Troupeau de grues' [etc.], *Texte*, pp. 398-9; CAPART, *Documents*, i, pl. 22; MURRAY, *Splendour*, pl. lxix [1]; SCHÜZ, *Über Stelzvögel* [etc.] in *Die Vogelwarte*, 23 (1966), Abb. 6 on p. 269; id. *Vögel der Pharaonen in Vogel-Kosmos*, Heft 11 (Nov. 1967), fig. on p. 374 [right lower]; COTTRELL, *Egypt*, fig. 1; MICHALOWSKI, *Art*, fig. 245.

(38) [1st ed. 51] Deceased at table, offering-list, six narrow registers of food-offerings, and **I-IV**, offering-bringers, with musicians on right in **III**, and **V-VI**, butchers.

STEINDORFF, Taf. 126-7; WILD, iii, pls. clvi-clxiii, details, pls. cxli, cxlii; GARDINER MSS. photos. 28.1068-71 (from Quibell). Offering-list, HASSAN, *Giza*, vi [2], pls. xxxiii-xl [37], p. 123. **I-VI**, DÜMICHEN, *Photo. Result.* ix. Group of butchers in **VI**, CAPART, *Memphis*, fig. 384.

(39) [1st ed. 52] Registers, **I-X**, two offering-bringers in each.

WILD, iii, pls. cxlviii [A], clxxx. **VIII-X**, STEINDORFF, Taf. 141.

(40) [1st ed. 53] False-door.

STEINDORFF, Taf. 139-40; WILD, iii, pls. clxxxiv, clxxxv, details, pl. clxxxvi [β , γ , ϵ]; CAPART, *Memphis*, fig. 302.

(41) [1st ed. 54] Narrow registers of food-offerings, and below, **I-II**, offering-bringers (facing partly left and partly right), **III**, butchers.

STEINDORFF, Taf. 137-8; WILD, iii, pls. clxxv-clxxix, detail, pl. cxlviii [B].

(42) [1st ed. 55] False-door.

STEINDORFF, Taf. 135 [left], 136 [left]; WILD, iii, pls. clxxxii, clxxxiii, details, pl. clxxxvi [α , δ].

(43) [1st ed. 56] Remains of ten registers, two offering-bringers in each.

STEINDORFF, Taf. 135 [right], 136 [right]; WILD, iii, pl. clxxx.

(44) [1st ed. 57-8] Deceased with wife and small son, and registers, **I**, men setting up clap-net, **II-III**, deceased directing fowling, with men waiting for birds to enter clap-net, and pulling rope, **IV**, men making net, and shed with men with fish and fowl, **V**, men cutting out roes, and netting fish, **VI**, scribes, and herdsmen tending cattle, **VII**, dwarf with monkey and man with dogs, attendants, mat-making, herdsmen in canoes and cattle crossing water, **VIII**, continued at (45) and (46), estates.

STEINDORFF, Taf. 115-18. Omitting deceased and family, **I**, and left ends of registers, GARDINER MSS. photos. on 28.1072-3 (from Quibell). **I-VII**, WILD, ii, pls. cxx-cxxvi, details, pls. lxxxvii-xciv. **I-III**, WOLF, *Kunst*, Abb. 189; WRESZ., *Atlas*, iii. 75; DUNHAM in *Boston Mus. Bull.* xxxv (1937), fig. on p. 51. **I**, MONTET, *Scènes*, fig. 9 on p. 43. Deceased and men pulling ropes in **II** and **III**, CAPART, *Memphis*, fig. 355. Deceased and clap-nets in **II** and **III**, MONTET, *Scènes*, pl. v. **IV-V**, WRESZ., *Atlas*, iii. 97 [C]. **IV**, men making net, and two men with fowl in shed, MONTET, *Scènes*, pls. vii [2], vi; shed with men, KEIMER in *Bull. Inst. Ég.* xxi (1938-9), pl. vi, p. 223; dried fish, roes, and fishing tackle hanging up in shed, MURRAY, *Saqqara Mastabas*, ii, pl. iv [1], p. 26; cf. KEIMER, op. cit. pp. 223-8 with fig. 5 (from MURRAY). Right part of **IV-VI**, CAPART, *L'Art ég.* iii, pl. 447. **V**, men cutting out roes, KEIMER, op. cit. pl. v, p. 222 [5]; EBERS, *Aegypten*, i, fig. on p. 188 [middle]; Eng. ed. fig. on p. 164 [middle]; netting fish, SCHÄFER and ANDRAE, *Kunst* (1925), 249 [upper]; (1930 and 1942), 261 [upper]; GAILLARD, *Recherches sur les poissons* [etc.], pl. i, fig. 1, fishes, figs. 8, 10, 13, 17, 19, 27, 32, 33, 37, 41, 43, 45, 51, 53, 55, 57, 58; fishermen on left, WEIGALL, *Anc. Eg. . . . Art*, 50 [top]; on right, DAUMAS in *B.I.F.A.O.* lxii (1964), fig. 11, pp. 80-1; MONTET, *Scènes*, pl. iv. Left part of **VI-VII**, id. ib. pl. xiii [2]. Middle part of **VI-VII**, CAPART, *Memphis*, fig. 223; ROSS, *The Art of Egypt*, pl. on p. 115 [middle]; LANGE, *Äg. Kunst*, pl. 33; id. *Lebensbilder*, Abb. 13; BYVANCK, *De Kunst*, pl. xxi [77]; PIJOÁN, *Summa Artis*, iii (1945), fig. 197. Right part of **VI-VIII**, WOLF, *Kunst*, Abb. 191; of **VI-VII**, WRESZ., *Atlas*, iii. 89; of **VI**, MONTET, *Scènes*, pl. viii; MICHALOWSKI, *Art*, fig. 240. Middle part of **VI**, RANKE, *The Art of Ancient Egypt*, and BREASTED, *Geschichte Aegyptens* (1936), 190. **VI**, men tending cattle on left, MONTET, *Scènes*, pl. ix [2]; WEIGALL, *Anc. Eg. . . . Art*, 51 [middle upper]; STEINDORFF, *Kunst*, 200 [lower]; milking, CAPART, *Documents*,

i, pl. 20; man tethering calves, ii, pl. 30 [B]; SAMEH, *Daily Life*, fig. on p. 13; tethered calf, KEIMER, *Bull. Inst. Ég.* xxxii (1949-50), fig. 26 on p. 99. **VII**, dwarf with monkey and man with dogs, SLOMANN in *Bulletins et Mémoires de la Société d'Anthropologie de Paris* (1927), pl. ii [4], p. 67; MURRAY, *Saqqara Mastabas*, ii, pl. iv [11], p. 26; mat-making, MONTET, *Scènes*, pl. vii [1]; cattle, GIEDION, *The Eternal Present*, ii, fig. 291; boat on right, MICHALOWSKI, *Art*, fig. 250. **VIII**, see *infra*, (44)-(46).

(45) [1st ed. 59] Deceased in canoe, with hippopotamus-hunt on right and man angling on left. Estates below, continued from (44) and at (46).

Omitting estates, STEINDORFF, Taf. 113, 114 [upper]; id. *Kunst*, 199; WILD, ii, pls. cxv-cxix, details, pls. lxxii, lxxiv [A], lxxxii-lxxxvi; DÜMICHEN, *Photo. Result.* xii [upper]; RANKE, *The Art of Ancient Egypt*, and BREASTED, *Geschichte Aegyptens* (1936), 186; SCHÄFER and ANDRAE, *Kunst* (1925), 247; (1930 and 1942), 259; CAPART, *L'Art ég.* iii, pls. 449-50; GALASSI in *Critica d'Arte*, n.s. ii (1955), fig. 262, pp. 313, 314; LANGE and HIRMER, *Aegypten. Architektur* (1955 and 1957), pl. 68; (1967), pl. 66; SCHÄFER, *Von äg. Kunst* (1963), Taf. 13; Eng. ed. *Principles of Egyptian Art*, pl. 22; WOLF, *Kunst*, Abb. 192; DE RACHEWILTZ, *L'Arte*, Tav. 43; WRESZ., *Atlas*, iii. 104 and Textabb. 104, 3 on p. 233; HAMANN, *Äg. Kunst*, Abb. 151, 151a; YOYOTTE, *Treasures*, pl. on p. 28; MICHALOWSKI, *Art*, fig. 76. Incomplete, REIL, *Wanderungen durch die Gräber in Saccara in Westermann's Jahrbuch der Illustrierten Deutschen Monatsheften* (1878), vol. 44, p. 629; BAIKIE, *A History of Egypt*, i, pl. xi [upper]; DE WIT, *Oud-Egyptische Kunst*, fig. 35; WOLDERING, *Götter*, Abb. 30; GARDINER MSS. photo. on 28.1074 (from Quibell). Upper part of deceased, LECLANT and RACCAH, *Dans les pas des Pharaons*, pl. 11. Hippopotamus-hunt, PRISSE, *L'Art ég.* ii, *Sculpture*, 10th pl. 'Chasse à l'hippopotame' [etc.], *Texte*, p. 398; CAPART, *Memphis*, fig. 353; LUGN, *Kunst*, fig. 41; LANGE, *Lebensbilder*, Abb. 12; TOUNY and WENIG, *Sport*, Taf. 57 (as Mereruka). Angling scene, GAILLARD, *Recherches sur les poissons* [etc.], pl. ii, fig. 2, with fishes, figs. 25, 47; SAMEH, *Daily Life*, fig. on p. 25 [upper]; DAUMAS in *B.I.F.A.O.* lxii (1964), fig. 2, p. 67. Pelican and goose, BOUSSAC in *Rec. Trav.* xxxiv (1912), fig. 1 on p. 164 and fig. 1 on p. 166. Ichneumons and birds, MONTET, *Scènes*, pl. i; CAPART, *Memphis*, fig. 381; id. *Paysage*, fig. 9 (by Daumas); MURRAY, *Saqqara Mastabas*, ii, pls. ii, iii [1], pp. 25-6. Fledgelings, CAPART in *Chron. d'Ég.* xvi (1941), fig. on p. 43. Estates, see *infra*, (44)-(46).

(46) [1st ed. 60-1] Registers (right part of **I-VI** above doorway), **I-II** (left part destroyed), men carrying bundles of papyrus, and building papyrus canoes, with deceased on right, **III**, boatmen jousting, **IV**, fishing with baskets from canoes, **V**, three groups ploughing, and milking cow on right, **VI**, sheep treading grain, shepherd's song above, and men hacking ground on right, **VII**, herdsmen with cattle fording canal, **VIII**, continued from (44) and (45), estates.

STEINDORFF, Taf. 110-12; WILD, ii, pls. cx-cxiv, details, pls. lxxv-lxxxi. **I-VII**, WRESZ., *Atlas*, iii. 39, 44; WOLF, *Kunst*, Abb. 193-5 (last from WRESZ.). **I**, CAPART, *Memphis*, fig. 371. **III-IV**, MONTET, *Scènes*, pl. iii. Two boats on right in **III**, MASPERO, *Hist. anc.* i, fig. on p. 70. **IV-VI**, SCHÄFER and ANDRAE, *Kunst* (1925), 250; (1930 and 1942), 262. **IV**, two boats, MASPERO, *Hist. anc.* i, fig. on p. 61 [lower]; left boat, GAILLARD, *Recherches sur les poissons* [etc.], pl. iii, fig. 3. **V-VII**, GARDINER MSS. photos. on 28.1076-8 (from Quibell). **V-VI**, MONTET, *Scènes*, pl. xv; MICHALOWSKI, *Art*, figs. 237-8; right part, CAPART, *Memphis*, fig. 373; RANKE, *Meisterwerke*, Abb. 42; LANGE, *Ägypten. Landschaft*, pl. 45. **V**, men ploughing, on left, MASPERO, *Hist. anc.* i, fig. on p. 67 [lower]; TZARA and SVED, *L'Égypte face à face*, pl. on p. 90; milking, PIJOÁN, *Summa Artis*, iii (1945), fig. 205. Sheep treading grain in **VI**, MASPERO, *Hist. anc.* i, fig. on p. 343; incomplete, WEIGALL, *Anc. Eg. . . . Art*,

51 [bottom]. Men with sheep in VI, and VII, LANGE and HIRMER, *Aegypten. Architektur* (1955 and 1957), pls. 70 [lower], 71; (1967), pls. 68 [lower], 69; *Great Museums*, fig. on p. 193 [22]; BRUNNER, *Hieroglyphische Chrestomathie*, Taf. 5. VI, sheep feeding from man's hand, PIJOÁN, op. cit. fig. 207; text of shepherd's song, KAPLONY in *Chron. d'Ég.* xlv (1969), pp. 30 [T], cf. 27-31; ALTENMÜLLER in ib. xlviii (1973), pp. 212 [1], cf. 211; men with hoes, MASPERO, op. cit. fig. on p. 67 [upper]; POSENER, SAUNERON and YOYOTTE, *Dict. civ.* fig. on p. 212. VII, EBERS, *Aegypten*, i, fig. on p. 187 [bottom]; Eng. ed. fig. on p. 163 [bottom]; SCHÄFER and ANDRAE, *Kunst* (1925), 249 [lower]; (1930 and 1942), 261 [lower]; MONTET, *Scènes*, pl. ix [1]; CAPART, *Memphis*, fig. 372; id. *L'Art ég.* iii, pl. 448 [upper]; id. *Paysage*, fig. 35; id. in GLANVILLE, *The Legacy of Egypt*, pl. 4 [4]; STEINDORFF, *Kunst*, 200 [upper]; GALASSI in *Critica d'Arte*, n.s. ii (1955), fig. 255, pp. 313, 349; MÜLLER (H. W.) in *Encyclopedia of World Art*, iv, pl. 335 [lower right]; right half, WEIGALL, *Anc. Eg. . . . Art*, 51 [top]; MURRAY, *Saqqara Mastabas*, ii, pl. iii [2], p. 26; MEKHITARIAN, *Egyptian Painting*, pl. on p. 11; PIRENNE, *Hist. civ.* i, pl. 72 [lower] facing p. 213; WOLF, *Hochkulturen*, Abb. 83; WESTENDORF, *Das Alte Ägypten*, fig. on p. 55; SAMEH, *Daily Life*, fig. on p. 148 [upper]; MICHALOWSKI, *Art*, fig. 239; man carrying calf, AVELINE and RACCAH, *Égypte*, pl. 33; DRIOTON and DU BOURGUET, *Pharaohs*, pl. 16 [upper]; ALDRED, *Egypt*, fig. 135; GROENEWEGEN-FRANKFORT and ASHMOLE, *Art of the Ancient World*, fig. 37; upper part of herdsman with stick over his shoulder, MONTET, *Scènes*, fig. 22 on p. 101. Left half, SCHÄFER, *Principles of Egyptian Art*, pl. 28. VIII, see below.

(44)-(46) [1st ed. 57-60] At bottom, estates. As register VIII of (44) and (46).

STEINDORFF, on Taf. 115, 118, 114, 112; WILD, ii, pls. cv-cix, details, pls. lxxiii, lxxiv [B]. Nos. 74-5 (of JACQUET-GORDON), AVELINE and RACCAH, *Égypte*, pl. 34. Nos. 74-6, MONTET, *Lives of the Pharaohs*, pl. on p. 45. Nos. 75, 81-3, LORET, *La Tombe d'un ancien Égyptien* in *Annales du Musée Guimet*, x (1886), pl. xxi [5th row right]. Nos. 76-9, *Chron. d'Ég.* iii (1927-8), pl. facing p. 150; CAPART, *Memphis*, fig. 188; MICHALOWSKI, *Art*, fig. 254. Nos. 77-9 and 88-90, CHAMPDOR, *L'Égypte des Pharaohs*, pls. on p. 30. Nos. 79-108, GARDINER MSS. photos. on 28.1073-7 (from Quibell). Nos. 86-8, MICHALOWSKI, *Piramidy i mastaby*, pl. 19. Nos. 88-9, KUSCH, *Ägypten im Bild*, Abb. 63. Nos. 88-91, DAUMAS, *Civ. de l'Ég.* pl. 66. Nos. 88-92, RANKE, *The Art of Ancient Egypt*, and BREASTED, *Geschichte Aegyptens* (1936), 202; DONADONI, *La Civiltà Egiziana*, fig. 13 facing p. 128. Nos. 89-92, LAURENT-TÄCKHOLM, *Faraos blomster*, pl. on p. 248. Nos. 92-9, STUART, *Nile Gleanings*, pl. iv facing p. 62 [lower]. Nos. 93-6, PERROT and CHIPIEZ, *Hist. de l'Art*, i, fig. 99. Nos. 93-102, DÜMICHEN, *Photo. Result.* xii [lower]. No. 97, SCHÄFER, *Principles of Egyptian Art*, pl. 26. Nos. 102-8, CAPART, *L'Art ég.* iii, pl. 448 [lower]. Text and names of estates, DÜMICHEN, *Resultate*, Taf. ii. Names, JACQUET-GORDON, *Domaines*, pp. 357, 363-5 [1785]. Nos. 73-108, cf. figs. 138, 140. Details, MURRAY, *Saqqara Mastabas*, ii, pls. iv [2-10], v [1-5], pp. 26, 27.

(47) and (48) [1st ed. 62-7] Pillars. Name and titles.

STEINDORFF, Taf. 105-8; WILD, ii, pls. xcvi-c.

(49)-(50), (51)-(52) Architraves with offering-texts.

Id. ib. pls. cii-civ. (49)-(50) STEINDORFF, Taf. 109.

Statues.

Deceased,¹ in Cairo Mus. CG 20. BORCHARDT, *Statuen*, i, Bl. 5, pp. 20-1; STEINDORFF, *Das Grab des Ti*, Taf. 1, 142-3; PERROT and CHIPIEZ, *Hist. de l'Art*, i, fig. 438; TARCHI, *L'Architettura*, Tav. 13 [upper left]; MASPERO, *Égypte*, fig. 122 (as Raḥnūfer); WEIGALL,

¹ Selected references.

Anc. Eg. . . . Art, 49; CAPART, *Memphis*, fig. 330; id. *L'Art ég.* (1909), pl. 14; *L'Art ég.* ii, pls. 241, 247; LANGE and HIRMER, *Aegypten. Architektur* (1955 and 1957), pls. 66-7; (1967), pls. 64-5; PIER, *Inscriptions of the Nile Monuments*, fig. 20 on p. 55; WRESZINSKI in *O.L.Z.* xix (1916), Taf. 3 [6], col. 12; DE WIT, *Oud-Egyptische Kunst*, fig. 22; MEIER-GRAEFE, *Pyramide und Tempel*, pl. 9; SMITH, *Hist. Eg. Sculp.* pl. 18 [e], p. 78; HORNEMANN, *Types*, i, pl. 120; DONADONI, *Egyptian Museum Cairo*, pls. on pp. 42 [right], 43; ANGIOLETTI and BIGONGIARI, *Testimone*, Tav. 7; upper part, MONTET, *Lives of the Pharaohs*, pl. on p. 37; ABBATE, *Arte egizia*, fig. 23; *Capolavori*, i, No. 10 (1963), fig. on p. 160 [left]; Eng. ed. fig. on p. 152 [left]; head, FECHHEIMER, *Plastik*, Taf. 34; LANGE, *Äg. Kunst*, pl. 27; id. *Ägyptische Bildnisse*, pl. 7; HUNGER and LAMER, *Altorientalische Kultur im Bilde*, Abb. 39; LEIBOVITCH, *Anc. Eg.* fig. 59; DRIOTON and DU BOURGUET, *Pharaohs*, pl. 28; GILBERT, *Méditerranée antique* [etc.], fig. 12; WESTENDORF, *Das Alte Ägypten*, fig. on p. 53; MÜLLER, *Äg. Kunst*, Abb. 39; see MASPERO, *Guide*, p. 84 [229].

Two statue-bases of son Demez, Overseer of the duck-pond and of the marsh-lands, etc., probably from here, in Cairo Mus. CG 305, 313. Texts, BORCHARDT, *Statuen*, i, pp. 182, 184.

No. 61 [D 21]. NEFERĤERENPTAĤ , Master of the largesse in the Mansion of Life, etc. Dyn. V or later.

MARIETTE, *Mastabas*, pp. 236-7, with plan.

Statue of deceased seated, in Cairo Mus. CG 76. BORCHARDT, *Statuen*, i, Bl. 17, pp. 62-3; texts, MARIETTE, op. cit. p. 237.

No. 62 [D 20]. WERIRNI , Overseer of the Treasury, Prophet of the Sun-temples of Userkaf and Neferirkarê, etc. Temp. Neferirkarê or later.

MARIETTE, *Mastabas*, pp. 231-5, with plan on p. 232.

Statues. All in Cairo Museum.

Deceased. Seated, CG 211; BORCHARDT, *Statuen*, i, Bl. 44, p. 142. Standing, CG 272; id. ib. Bl. 58, p. 172; text, MARIETTE, op. cit. pp. 233 [upper], 235.

Kaiemked¹ , ka-servant of the endowment of Werirni, kneeling, CG 119. BORCHARDT, *Statuen*, i, Bl. 26, p. 91; id. in *Ä.Z.* xxxv (1897), fig. on p. 119; MASPERO, *Hist. anc.* i, fig. on p. 408 [right]; id. *L'Arch. ég.* (1887), fig. 186; (1907), fig. 198; id. *Essais*, pl. iii facing p. 70, cf. pp. 68-73; id. *Eg. Art*, pl. facing p. 74, cf. pp. 74-8; id. *Égypte*, fig. 162; id. *Scribe agenouillé* in RAYET, *Monuments de l'art antique*, i, Livraison VI, pl. xv; id. *Guide*, pp. 69-70 [152] with fig. 22; PERROT and CHIPIEZ, *Hist. de l'Art*, i, fig. 440; WEIGALL, *Anc. Eg. . . . Art*, 43 [upper]; MARIETTE, *Album du Musée de Boulaq* (1872), pl. 20 [769]; JÉQUIER, *Hist. civ.* fig. 123; CAPART, *Memphis*, fig. 340; SPRINGER, *Die Kunst des Altertums* (1915), Abb. 64; (1923), Abb. 59; BOREUX, *L'Art ég.* pl. xxv; VON BISSING, *Äg. Kunstgeschichte*, Taf. lxx [398], *Text*, i, p. 156; *Encycl. phot. Caire*, pl. 33; LANGE (K.), *Ägyptische Bildnisse*, Taf. 10; SHOUKRY, *Privatgrabstatue*, Abb. 2; RIESTERER, *Kunstschätze . . . Kairo*, pl. 12; ALDRED, *O.K. Art*, pl. 44; JAMES, *Egyptian Sculptures*, pl. 3; SAMEH, *Daily Life*, fig. on p. 153; HORNEMANN, *Types*, iii, pl. 570; MALRAUX, *Le Musée imaginaire de la sculpture mondiale*, pl. 40; *Great Museums*, pl. 25; DONADONI, *Egyptian Museum Cairo*, pl. on p. 47.

Iti , woman, grinding corn, CG 110. BORCHARDT, *Statuen*, i, Bl. 24, p. 86; id. *Das Grabdenkmal des Königs Nefer-ir-ker-er*, Abb. 5; id. *Works of Art*, pl. 4; id. in *Ä.Z.* xxxv (1897), p. 122 with fig.; PERROT and CHIPIEZ, *Hist. de l'Art*, i, figs. 450-2; TARCHI,

¹ Selected references.

L'Architettura, Tav. 12 [right lower]; MASPERO and ROEDER, *Führer*, Taf. 7; WEIGALL, *Anc. Eg. . . . Art*, 54 [lower left]; CAPART, *L'Art ég.* ii, pl. 263; HORNE-MANN, *Types*, iv, pl. 1032; WHITE, *Everyday Life in Ancient Egypt*, fig. 106; *I.L.N.* July 7, 1962, fig. on p. 34 [bottom right]; Amsterdam. 5000 jaar, fig. 11 [29]; Brussels. 5000 ans, fig. 15, p. 23 [17]; Louisiana. 5000 års, No. 68 with fig.; Vienna. 5000 Jahre, No. 29 with Abb.; Essen. 5000 Jahre, No. 41 with Abb.; PERC, *Spomeniki starega Egipta* (1974), No. 12 with fig. See MASPERO, *Guide*, p. 75 [172] (as man); MARIETTE, *Mastabas*, pp. 233-4, with text; BREASTED (Jr.), *Eg. Servant Statues*, pp. 17-18 [Type 2, 1].

Ishat , woman, grinding corn, CG 114. BORCHARDT, *Statuen*, i, Bl. 25, pp. 88-9; MASPERO, *Hist. anc.* i, fig. on p. 320; id. *Égypte*, fig. 124; id. *Guide*, p. 75 [171] with fig. 25; PERROT and CHIPIEZ, *Hist. de l'Art*, i, figs. 48, 449; WEIGALL, *Anc. Eg. . . . Art*, 54 [lower right]; MARIETTE, *Album du Musée de Boulaq* (1872), pl. 20 [759]; CAPART, *Memphis*, fig. 343; HORNE-MANN, *Types*, iv, pl. 1034; DE WIT, *Oud-Egyptische Kunst*, fig. 40; DRIOTON and SVED, *Art ég.* fig. 29 (foreground); ALDRED, *O.K. Art*, pl. 54; LANGE and HIRMER, *Aegypten. Architektur* (1955 and 1957), pl. 56; DE RACHEWILTZ, *L'Arte*, Tav. 47; SAMEH, *Daily Life*, fig. on p. 40; *Great Museums*, pl. 23; WENIG, *Die Frau*, pl. 17 [lower]; DONADONI, *Egyptian Museum Cairo*, pl. on p. 48 (called CG 110); MENDELSSOHN, *The Riddle of the Pyramids*, pl. 4; FISCHER in *Metropolitan Museum Journal*, 8 (1973), fig. 10, p. 8. Text, MARIETTE, *Mastabas*, p. 234 [upper].

Wehemnefert , woman, straining beer, CG 118. BORCHARDT, *Statuen*, i, Bl. 26, pp. 90-1; MASPERO, *Hist. anc.* i, fig. on p. 407; id. *Guide*, p. 75 [169] with fig. 24; MARIETTE, *Album du Musée de Boulaq* (1872), pl. 20 [758]; PERROT and CHIPIEZ, *Hist. de l'Art*, i, fig. 448; HORNE-MANN, *Types*, iv, pl. 981. Text, MARIETTE, *Mastabas*, p. 234 [lower].

Man cleaning jar, CG 116. BORCHARDT, *Statuen*, i, Bl. 26, pp. 89-90. See BREASTED (Jr.), *Eg. Servant Statues*, p. 46 [lower, 3].

No. 63 [D 19]. KAI  , Chief Justice and Vizier, etc. Middle Dyn. V or later.

MARIETTE, *Mastabas*, pp. 226-31, with plan on p. 226.

Three offering-stands, in Cairo Mus. CG 1299, 1302-3. CG 1299, id. ib. p. 229 [middle]. CG 1302, id. *Album du Musée de Boulaq* (1872), pl. 11 [right]. Texts, BORCHARDT, *Denkmäler*, i, pp. 3, 4.

South Chapel.

North wall of Pillared Hall. False-door; texts, MARIETTE, op. cit. pp. 228, 229 [left, right]; names and titles of deceased and sons, DE ROUGÉ, *Inscr. hiéro.* pls. xcix [top], ciii [lower].



North Chapel.

False-door. Texts, MARIETTE, op. cit. pp. 230-1.

Possibly from here.

False-door, in Cairo Mus. JE 15159.

Block with name and titles, in Brit. Mus. 65952. *Hiero. Texts*, i², pl. xxi [5], p. 22.

No. 64 [D 18]. NUBNEBTI  , King's wife, etc. Dyn. V or later.

MARIETTE, *Mastabas*, pp. 225-6, with plan of chapel.

Doorway. Drum with name and titles and lintel with offering-text; id. ib. p. 225.

No. 65 [D 17]. NIMA^cETRĒ^c , *sem*-priest, Director of the kilt, etc. Middle Dyn. V or later.

MARIETTE, *Mastabas*, pp. 221-4, with plan on p. 222.

Statues. In Cairo Museum.

Deceased, CG 51. BORCHARDT, *Statuen*, i, Bl. 13, pp. 45-6; text, MARIETTE, *op. cit.* p. 224 [504].

Ptaḥshepes , Judge and Inspector of book-keepers. (a) CG 97; BORCHARDT, *op. cit.* Bl. 22, pp. 76-7; kilt, ENGELBACH, *Introduction*, fig. 30; text, MARIETTE, *op. cit.* p. 224 [497]. (b) Seated, CG 214; BORCHARDT, *op. cit.* Bl. 45, p. 143; text, MARIETTE, *op. cit.* p. 224 [496]. (c) Seated, granite, possibly from here, CG 164; BORCHARDT, *op. cit.* Bl. 36, p. 117.

No. 66 [C 24]. RA^cḤOTP , Inspector of scribes of the royal documents, etc. Dyn. V.

MARIETTE, *Mastabas*, pp. 157-9, with plan of chapel.

False-door. Name and title of son Akh(ti)ḥotp , Judge and Overseer of scribes, *id. ib.* p. 158.

Statues of deceased.

In Cairo Museum.¹

Double-stature, mother(?) seated and deceased, fragmentary, CG 107, 312. BORCHARDT, *Statuen*, i, Bl. 23, pp. 84, 184; CG 107, HORNEMANN, *Types*, v, pl. 1175.

Scribe-stature, alabaster, CG 127. BORCHARDT, *op. cit.* Bl. 28, p. 96; HORNEMANN, *op. cit.* ii, pl. 404.

Scribe-stature, granite, CG 163. BORCHARDT, *op. cit.* Bl. 36, pp. 116-17; VON BISSING, *Äg. Kunstgeschichte*, Taf. lxxv [396].

Standing, CG 130. BORCHARDT, *op. cit.* Bl. 29, p. 98; HORNEMANN, *op. cit.* i, pls. 122-3.

Standing, granite, CG 172. BORCHARDT, *op. cit.* Bl. 38, p. 121; HORNEMANN, *op. cit.* i, pl. 216.

Base, found at Abûsîr, CG 303. Text, BORCHARDT, *op. cit.* p. 181.

Seated, granite, CG 182-5, 187-8, 192, 194. *Id. ib.* Bl. 39 [185], 40 [187], pp. 126-7, 128-9, 131, 132; CG 185, see MASPERO, *Guide*, p. 71 [155].

In other museums.

Standing, in Aberdeen Mus. 1385. REID, *Illustrated Catalogue* [etc.] (1912), fig. on p. 179, *cf.* p. 178; ALDRED, *O.K. Art*, pl. 47; SWAN HALL in *Apollo*, lxxxvii (1968), fig. 15, p. 169.

Scribe-stature, granite, in Athens, Nat. Mus. 919. CAPART, *Recueil*, ii, pl. lii; text, MALLET in *Rec. Trav.* xviii (1896), p. 8 [919].

Scribe-stature, granite, in New York, M.M.A. 25.9. LANSING in *M.M.A. Bull.* xxi (1926), pp. 38-43 with figs.; HAYES, *Scepter*, i, fig. 61, pp. 109-10; WOLF, *Die Welt der Ägypter*, Taf. 26; ALDRED, *O.K. Art*, pl. 48.

¹ For another statue which might have come from here, see tomb No. 28 [D 35].

No. 67 [D 16]. $\text{ANKHMA}^{\text{C}}\text{KA} \text{𓆎} \text{𓆏} \text{𓆑}$, Prophet of Rē^c in the Sun-temples of Userkaf and Neferirkarē^c, Prophet of Saḥurē^c and of the Pyramid of Neuserrē^c, etc. Temp. Neuserrē^c or later.

Plan XLIX.

MARIETTE, *Mastabas*, pp. 213–20, with plan of niche on p. 213. Names and some titles, DE ROUGÉ, *Recherches sur les monuments* [etc.] (1866), p. 91 (repr. in *Bibl. Ég.* xxvi, pp. 87–8); LIEBLEIN, *Djct.* No. 25.

Niche. (a) and (b) Offering-bringers and butchers, (c) false-door, in Cairo Mus. CG 1485. (a) and (b) Texts, MARIETTE, op. cit. p. 213. (c) BORCHARDT, *Denkmäler*, i, Bl. 40, pp. 182–6; MARIETTE, op. cit. pp. 214–18; deceased and son, on right outer jamb, FECHHEIMER, *Plastik* (1914), Taf. 109; (1923), Taf. 119; son holding hoopoe, on left outer jamb, KEIMER in *B.I.F.A.O.* xxx (1931), pl. iii, p. 310 [g]; some texts, DE ROUGÉ, *Inscr. hiéro.* pls. lxxxiv [bottom], lxxxv [bottom]; see MASPERO, *Guide*, p. 28 [41].

Offering-table, in Cairo Mus. CG 1327. BORCHARDT, *Denkmäler*, i, Bl. 4, p. 12; VANDIER, *Manuel*, ii, fig. 308 [right near bottom], p. 528 (as 1329); MARIETTE, op. cit. p. 219–20.

No. 68 [C 4]. $\text{KHA}^{\text{C}}\text{MERERPTAḤ} \text{𓆑} \text{𓆒} \text{𓆓}$, Overseer of all works of the King, etc. Dyn. V.

MARIETTE, *Mastabas*, pp. 117–20, with plan of niche.

False-door, with sons (including Sopduhotp, tomb No. 69 [D 15]), in Cairo Mus. CG 57126. Id. ib. pp. 118–20; offering-list, HASSAN, *Giza*, vi [2], pls. lxxv–lxxii [75], p. 134; parts of text, DE ROUGÉ, *Inscr. hiéro.* pl. c; see MASPERO, *Guide*, p. 59 [131]; GRDSELOFF in *Ann. Serv.* xxxix (1939), p. 390–1.

No. 69 [D 15]. $\text{SOPDUḤOTP} \text{𓆑} \text{𓆒} \text{𓆓}$, Judge and Overseer of scribes, etc. Dyn. V or later.

Plan XLIX.

Father, Kha^cmererptaḥ (tomb No. 68 [C 4]).

MARIETTE, *Mastabas*, pp. 209–12, with plan on p. 209.

Chapel.

(1) Doorway. (a) and (b) Deceased and small son, with offering-bringers at (a) and butchers at (b), in Turin Mus. Sup. 1255–6. (c) Drum with name and titles. (d) and (e) Deceased.

(a) and (b) FARINA, *Il Regio Museo di antichità di Torino* (1931), pls. on p. 39; (1938), pls. on pp. 40 [left], 41 [left]; one, MARBURG INST. photo. 68764; see GRDSELOFF in *Ann. Serv.* xxxix (1939), p. 390. (a) GARDINER MSS. photo. 28.480. (c) Text, MARIETTE, op. cit. p. 210 [top]. (d) and (e) See id. ib. p. 210 [near top].

(2) Five remaining registers of reaping corn, piling up sheaves, threshing with donkeys, winnowing, and feeding fowl.

See id. ib. p. 212 [d] (texts).

(3) Registers, I–II, bringing wild animals, III, overthrowing bull, IV, offering-bringers. Block from left part of II, in Cairo Mus. CG 1543.

See id. ib. pp. 211–12 [c] (texts). Cairo Mus. CG 1543, BORCHARDT, *Denkmäler*, ii, Bl. 54, p. 2; PERROT and CHIPIEZ, *Hist. de l'Art*, i, fig. 29 [upper]; texts, ČERNÝ Notebook, 118, p. 87; see MASPERO, *Guide*, pp. 86–7 [232 C].

(4) False-door. Texts, MARIETTE, op. cit. p. 211 [b].

(5) Registers, **I**, fishing, **II**, netting fowl, and man cutting open fish, **III**, herdsmen in boats and cattle crossing water, **IV**, herdsmen with cattle crossing water, with boat behind. Blocks in Cairo Mus. CG 1671, 1739, 1555, 1557.

See MARIETTE, op. cit. p. 210 [a] (texts). Cairo Mus. CG 1671, 1739, 1555, 1557, BORCHARDT, *Denkmäler*, ii, Bl. 60, 95 (incomplete), 61, pp. 128, 165, 16, 18; texts, ČERNÝ Notebook, 118, pp. 91, 92. CG 1671, DUNHAM in *J.A.O.S.* 56 (1936), fig. 2, p. 174 (squeeze in Boston Mus. 78.164). CG 1555, Louisiana. 5000 *ars*, No. 70 with fig.; Brussels. 5000 *ans*, fig. 12, p. 22 [11]; Essen. 5000 *Jahre*, No. 47 with Abb.; London. 5000 *Years*, pl. v [upper], p. 15 [33]; herdsmen, BORCHARDT in *Ä.Z.* 44 (1907), Abb. 4, p. 79; see MASPERO, *Guide*, p. 86 [232 E]; squeeze in Boston Mus. 78.149, see DUNHAM, op. cit. p. 174. CG 1557, PERROT and CHIPIEZ, *Hist. de l'Art*, i, figs. 22-3, 459; AMÉLINEAU, *Hist. sépulture*, ii, pl. xl [5th row right]; GRIFFITH INST. photo. 346 [right].

No. 70 [D 14]. KHUIT ⲕⲏⲓⲧ , King's daughter, King's wife, etc. Late Dyn. V or Dyn. VI.

Name and titles from drum and thickness of doorway and two blocks, MARIETTE, *Mastabas*, pp. 207-8.

False-door, in Cairo Mus. JE 15160. See id. *Notice des principaux monuments . . . à Boulaq* (1869), p. 294 [24].

No. 71 [B 1]. THENTI ⲧⲏⲧⲏⲧ , Prophet of Khufu and Khnum foremost of Herwēr ⲏⲣⲱⲓⲣ in all his places, Overseer of the expedition, etc. Middle Dyn. IV or later.

Wife, Iynefert ⲓⲛⲉⲫⲏⲧ , Royal acquaintance.

MARIETTE, *Mastabas*, pp. 87-9, with plan of chapel.

False-door (blocks in Cairo Mus. CG 57136, 57138, 57140, and drum, CG 57141). Id. ib. pp. 88-9; some texts, DE ROUGÉ, *Inscr. hiéro.* pl. lxxviii [upper]; blocks in Cairo, see SMITH (W. S.) in REISNER, *Tomb Development*, p. 404 (57140 called 57160).

No. 72 [C 18]. THENTI ⲧⲏⲧⲏⲧ , Chief Justice and Vizier, etc. Middle Dyn. V or later.

MARIETTE, *Mastabas*, pp. 148-9, with plan of chapel.

Lintel of doorway with offering-text. Text, id. ib. p. 149; VASSALLI MSS. 12 [top].

No. 73 [D 13]. SHEPSI ⲑⲏⲑⲥⲓ , Judge and Overseer of scribes, etc. Probably early Dyn. V.

Wives, Zefatsen ⲑⲉⲫⲁⲧⲥⲏ and Hetepheres ⲏⲧⲉⲫⲏⲑⲏⲣⲉⲥ , Prophetesses of Hathor.

MARIETTE, *Mastabas*, pp. 206-7, with plan of chapel.

Palace-façade false-door, in Cairo Mus. CG 1379. BORCHARDT, *Denkmäler*, i, Bl. 9, pp. 36-7; BALCZ in *Mitt. Kairo*, 1 (1930), Taf. xvi, p. 53; texts, MARIETTE, op. cit. p. 207 (additional text); see MASPERO, *Guide*, p. 29 [47].

No. 74 [D 12]. NIANKH-SEKHMET ⲛⲓⲁⲛⲕⲏⲑⲧⲉⲥⲏⲕⲏⲙⲉⲧ , Greatest of the physicians of the Great House, etc. Temp. Saḥurē.

MARIETTE, *Mastabas*, pp. 202-5, with plan.

False-door, presented by Saḥurē, in Cairo Mus. CG 1482. BORCHARDT, *Denkmäler*, i,

Bl. 39, pp. 169–73; MARIETTE, op. cit. pp. 203–5; figures on left jambs, GHALIOUNGUI, *Magic and Medical Science* (1973), pl. 8. Text on inner jambs, SETHE, *Urk.* i. 38–40 [26, A, B]; MASPERO in *P.S.B.A.* xi (1889), pp. 304, 306 (repr. in *Bibl. Ég.* viii, pp. 333–6). See id. *Guide*, p. 15 [31].

No. 75 [D 10]. $\text{TEPEM}^{\text{CANKH}}$ [I] $\text{𓂏} \text{𓂏} \text{𓂏}$, Chief Justice and Vizier, Inspector of prophets of Hathor of the *mert*-temple of Unis, etc. End of Dyn. V or Dyn. VI.

MARIETTE, *Mastabas*, pp. 193–5, with plan.

Offering-room.

East and south walls. Offering-bringers and butchers; see id. ib. pp. 193–4 [A, B] (texts).

West wall. Butchers, and false-door; texts and false-door, id. ib. pp. 194 [C], 195; texts of false-door, SETHE, *Urk.* i. 190–1 [30 (121)], 68–9 [45]; parts, DE ROUGÉ, *Inscr. hiéro.* pl. xci [lower right].

North subsidiary niche.

Lintel and panel of false-door, in Cairo Mus. CG 1509–10. BORCHARDT, *Denkmäler*, i, Bl. 45, p. 215; texts, MARIETTE, op. cit. pp. 456–7 [H 11], cf. 194 [D].

Statues of deceased. In Cairo Museum. From serdab.

Standing, wood, CG 154. BORCHARDT, *Statuen*, i, Bl. 34, pp. 111–12; PERROT and CHIEPIEZ, *Hist. de l'Art*, i, fig. 461; RICHER, *Le Nu*, fig. 57; BULLE, *Der schöne Mensch im Altertum* (1898), Taf. 4 [right]; (1912), Taf. 5 [right]; MASPERO, *Égypte*, fig. 155; see id. *Guide*, p. 51 [99].

Scribe-stature, granite, CG 162. BORCHARDT, op. cit. i, Bl. 36, p. 116.

No. 76 [D 11]. $\text{TEPEM}^{\text{CANKH}}$ [II] $\text{𓂏} \text{𓂏} \text{𓂏}$, *warb*-priest of the Pyramids of Snefru, Khephren, Menkaurē, Userkaf, and Sahurē, Prophet of Khufu and Menkaurē, and of the Sun-temple of Userkaf, etc. Middle Dyn. V.

Plan XLIX.

Wife, Nubhotp $\text{𓂏} \text{𓂏} \text{𓂏}$ Bebi $\text{𓂏} \text{𓂏}$, Prophetess of Hathor and Neith, etc.

MARIETTE, *Mastabas*, pp. 196–201, with plan of chapel.

I. Passage.

(1) Deceased with two women, cooking-scene, and estates at bottom.

See id. ib. p. 196 [A] (texts). Names of estates, JACQUET-GORDON, *Domaines*, pp. 343–4 [10S5], cf. figs. 126–7.

(2) False-door of son Hem-min $\text{𓂏} \text{𓂏}$ in Cairo Mus. CG 1417 (as 1415 in 1st ed.).

BORCHARDT, *Denkmäler*, i, Bl. 20, pp. 89–91; MARIETTE, op. cit. fig. on p. 200; VON BISSING, *Denkmäler*, i, Taf. 17; id. *Äg. Kunstgeschichte*, Taf. lix [369]; VANDIER, *Manuel*, ii, fig. 272 [lower left]. Text of right outer jamb, SETHE, *Urk.* i. 33 [19, B]. Head from left inner jamb, WRESZ., *Atlas*, iii, Textabb. 75, 3 on p. 158. See MASPERO, *Guide* (1914), p. 68 [172].

(3) Bringing animals to deceased. Block in Copenhagen, Nationalmuseet, 5491.

Short text, MARIETTE, op. cit. p. 197 [C]. Block in Copenhagen, see *Egypt and Western Asia* (1968), p. 19 [7, 2nd item].

(4) False-door of wife, in Cairo Mus. CG 1415 (as 1417 in 1st ed.).

BORCHARDT, *Denkmäler*, i, Bl. 19, pp. 84-7; MARIETTE, op. cit. fig. on p. 201. Dedication, SETHE, *Urk.* i. 33 [19, A].

(5) [1st ed. incorrectly placed] Deceased with two(?) men and three women behind, and metal-workers and carpenters, chiefs rendering accounts, bartering, and three boats. Block with three women, formerly in von Bissing Colln. and The Hague, Scheurleer Mus., now in Leyden Mus. F.1939/2.10. Adjoining blocks, chiefs, in Cairo Mus. CG 1541; two men and boys with baboons, CG 1556; man with fish, formerly in von Bissing Colln. and The Hague, Scheurleer Mus., now in Brussels, Mus. Roy. E.7297; men bartering, in London, Univ. Coll. 14310. Craftsmen and prow of boat, in London, Univ. Coll. 14309.

Leyden Mus. F.1939/2.10, VON BISSING in *Bull. Antieke Beschaving*, ix [2] (Dec. 1934), fig. 5, pp. 6-7 [9]. Reconstruction of adjoining blocks, SMITH (W. S.) in *A.ĵ.A.* xlvi (1942), fig. 5, pp. 515-16. Cairo Mus. CG 1541, BORCHARDT, *Denkmäler*, i, Bl. 52, p. 244; texts, ČERNÝ Notebook, 118, p. 87; see MASPERO, *Guide*, pp. 81-2 [204]. Cairo Mus. CG 1556, BORCHARDT, op. cit. ii, Bl. 61, pp. 17-18; MASPERO, *Le Musée Égyptien*, ii, pl. xi [top], pp. 30-2; id. *Égypte*, fig. 110; CAPART, *Rue de Tombeaux*, pl. ciii [top], pp. 36, 65; FORMAN (W. and B.) and VILÍMKOVÁ, *Eg. Art*, pl. 26; WOLF, *Kunst*, Abb. 201; details of scene with baboons, LANGE, *Lebensbilder*, Abb. 9; SAMEH, *Daily Life*, fig. on p. 30; SMITH, *Hist. Eg. Sculp.* fig. 225 [c], pp. 182 with note 1, 187, 340; male baboon, BÉNÉDITE in *Mon. Piot*, xix (1911), fig. 11, pp. 27-8; texts, ČERNÝ Notebook, 118, pp. 91-2; see MASPERO, *Guide*, p. 87 [235]. Brussels, Mus. Roy. E.7297, VON BISSING, op. cit. fig. 3, pp. 5-6 [7]; WERBROUCK in *Bull. Mus. Roy.* 3 Sér. x (1938), fig. 11, pp. 137-8. London, Univ. Coll. 14310, CAPART, *Recueil*, pl. xiii; No. 14309, id. ib. pl. xii; SMITH (W. S.) in *A.ĵ.A.* xlvi (1942), fig. 6, p. 516. Texts of boats and people behind deceased, MARIETTE, *Mastabas*, pp. 197-8 [F].

II. Offering-room.

(6) and (7) [1st ed. 8] Bottom registers, offering-bringers and butchers. Texts, id. ib. p. 199 [lower].

(8) [1st ed. 7] False-door, in Cairo Mus. CG 1564.

BORCHARDT, *Denkmäler*, ii, Bl. 64, pp. 28-30. Texts, MARIETTE, op. cit. pp. 198-9. See MASPERO, *Guide*, p. 29 [45].

Blocks. Possibly from here

Upper part of deceased, with remains of two men, formerly in Paris, Musée Guimet, now in Louvre, AF.6760. MORET, *Catalogue du Musée Guimet. Galerie Égyptienne*, i, in *Annales du Musée Guimet*, xxxii (1909), pl. lxx [B 10], pp. 143-4; GRDSELOFF in *Ann. Serv.* xxxix (1939), fig. 16, pp. 385-7; see MONOD-BRUHL, *Guide-Catalogue du Musée Guimet*, p. 196 [270c].



Two men holding rope, from netting scene, formerly in von Bissing Colln. and The Hague, Scheurleer Mus., now in Leyden Mus. F.1939/2.8. VON BISSING in *Bull. Antieke Beschaving*, ix [2] (Dec. 1934), fig. 4, p. 6 [8]; see SMITH (W. S.) in *A.ĵ.A.* xlvi (1942), p. 516.

Two *ka*-servants with offerings, formerly in von Bissing Colln., now in Leyden Mus. F.1939/2.11.

No. 77 [D 9]. MERUKA , Overseer of scribes of the royal documents of all works of the King, etc. Dyn. V.

MARIETTE, *Mastabas*, p. 192.

Name and titles, from remains of false-door, id. ib. p. 192.

No. 78 [D 1; S 901]. NETERUSER         , Overseer of all works of the King, Director of scribes of petitions, etc. Temp. Menkauhor to Isesi.

Plan XLIX.

Wife, Khenut                  , King's adorer, 'Sister of the endowment'.

Chapel. In Chicago, Field Mus. Nat. Hist. A.24450.

MURRAY, *Sagqara Mastabas*, i, pp. 19-24, with plan, pl. xxxii [bottom]; MARIETTE, *Mastabas*, pp. 164-74, with plan of part on p. 165. Texts, SETHE in MURRAY, op. cit. ii, pp. 18-21. See QUIBELL in *Egypt Exploration Fund. Archaeological Report 1907-8*, p. 14 [m].

Room II.

(1) [Part of 1st ed. 4, incorrectly placed] Drum with name and title.

MURRAY, op. cit. i, pl. xxv ['drum of outer door'].

Room III.

(2) [1st ed. 1-3] Niche. (a) and (b) Deceased seated, with wife squatting; (c) false-door.

Id. ib. i, pl. xxiv. Texts, MARIETTE, op. cit. pp. 165 [lower], 166 [top].

Room IV.

(3) [1st ed. 4-6] Doorway. (a)-(b) Jambs with remains of offering-bringers, left part of lintel with name and titles and deceased seated, and drum with name and title; (c) and (d) remains of offering-bringers.

MURRAY, op. cit. i, pl. xxv [except 'drum of outer door']. Three lower lines of lintel, MARIETTE, op. cit. p. 166 [middle]. Texts of (c) and (d), id. ib. p. 166 [bottom]; id. in *Rev. Arch.* n.s. xix (1869), pl. iii [b, 5th and 6th cols.] facing p. 82.













(4)-(5) [1st ed. 7-8] Food-offerings (above doorway), and three registers of men bringing animals on either side.

MURRAY, op. cit. i, pl. xxii. Texts in II-III at (4), MARIETTE, *Mastabas*, p. 167 [upper].

(6) and (7) [1st ed. 9, 11] Deceased at table, with offering-list, priests, sons Ra'shepses (tomb, probably LS 16) and Neteruser, offering-bringers and butchers.

MURRAY, op. cit. i, pls. xxi, xxiii. Incomplete texts, MARIETTE, *Mastabas*, pp. 167 [lower]-171. Some offering-bringers and butchers from (6), MARTIN, *Mummies*, figs. on pp. 16-17.

(8) [1st ed. 10] False-door. MURRAY, op. cit. i, pl. xx; MARIETTE, *Mastabas*, pp. 173-4.

No. 79 [D 2; S 905]. KAEMREHU            , Secretary of the Toilet-house, Prophet of the Pyramid of Neuserre, etc. Late Dyn. V.

Plan XLIX.

MOGENSEN, *Le Mastaba Égyptien de la Glyptothèque Ny Carlsberg* (hereafter MOGENSEN, *Mastaba*); KOEFOED-PETERSEN, *En Stormandsgrav fra det gamle Aegypten in Tilskueren*, 1936, pp. 434-46 (hereafter KOEFOED-PETERSEN, *Stormandsgrav*); MARIETTE, *Mastabas*, pp. 175-7. Plan of chapel, id. ib. p. 175; MOGENSEN, *Mastaba*, p. xiii [right]; id. *Coll. ég.* pl. lxxxvi [right]; KOEFOED-PETERSEN, *Stormandsgrav*, fig. 2 (last three by Quibell).

Offering-table, in Cairo Mus. CG 1370. MARIETTE, op. cit. p. 161; text, BORCHARDT, *Denkmäler*, i, p. 32.

Chapel. Unless otherwise stated in Copenhagen, Ny Carlsberg Glypt. Æ.I.N.1271.

(1) Doorway. (a) Lower part of deceased. (b) Drum with name and title, in Cairo Mus. CG 1734. (c) Fragment with butcher.

(a) MOGENSEN, *Mastaba*, fig. 2; id. *Coll. ég.* pl. lxxxvii [right], p. 84; KOEFOED-PETERSEN, *Cat. des bas-reliefs*, pl. ii, pp. 7 [I, A], cf. 67. (b) BORCHARDT, *Denkmäler*, ii, Bl. 94, p. 163. (c) MOGENSEN, *Mastaba*, fig. 1; see KOEFOED-PETERSEN, *Cat. des bas-reliefs*, p. 7 [I, B].

(2) [1st ed. 1] Registers, **I** (lower half only), donkeys threshing, storing grain, winnowing, **II**, corn-measurers and scribes, overseers rendering accounts, scribes, and granaries, **III**, brewing and baking, **IV**, carpenters, dwarfs making jewelry, metal-workers, sculptors and vase-makers, in Cairo Mus. CG 1534.

BORCHARDT, *Denkmäler*, i, Bl. 48, pp. 232-5; MOGENSEN, *Mastaba*, pls. viii, ix, figs. 18, 19, 21, 24-6, 29, 31-5, 38-42, 44-5; WRESZ., *Atlas*, i. 402-4. **II**, rendering accounts, scribes, and granaries, PERROT and CHIPIEZ, *Hist. de l'Art*, i, figs. 18, 19, 282; one man, SAMEH, *Daily Life*, fig. on p. 141 [upper]. **III**, BORCHARDT in *Ä.Z.* xxxv (1897), fig. on p. 129 [middle]; ENGELBACH in GLANVILLE, *The Legacy of Egypt*, pls. 30-1; straining beer and kneading dough, PERROT and CHIPIEZ, op. cit. fig. 24; pounding grain, SAMEH, op. cit. fig. on p. 39 [upper]. Middle part of **III-IV**, HUSSEIN, *Vom Papyrus zum Codex*, pl. on p. 32. Some bakers and sculptors in **III-IV**, PETRIE GIZA photo. 551. **IV**, dwarfs making jewelry, VERNIER, *La Bijouterie et la joaillerie égyptiennes*, fig. 180, p. 134; MONTET, *Scènes*, fig. 39; beating, melting, and weighing metal, PERROT and CHIPIEZ, op. cit. figs. 21, 501; weighing, SAMEH, op. cit. fig. on p. 140 [upper]. Sculptors and vase-makers in **IV**, ENGELBACH, *Introduction*, pl. ix [1]; omitting one vase-maker, id. in GLANVILLE, *The Legacy of Egypt*, pl. 25 [20]; sculptors, KOEFOED-PETERSEN, *Stormandsgrav*, fig. 6; DE RACHEWILTZ, *L'Arte*, Tav. 11; SAMEH, op. cit. fig. on p. 55; WESTENDORF, *Das Alte Ägypten*, fig. on p. 64. See MASPERO, *Guide*, p. 41 [79].

(3) [1st ed. 2] Registers, **I**, [deceased seated], **II**, offering-bringers, and men bringing **III**, bulls, **IV**, wild animals, **V**, fowl.

MOGENSEN, *Mastaba*, pl. vii, figs. 14-17; id. *Coll. ég.* pl. lxxxviii [upper], p. 85; SÉE, *Naissance*, fig. on p. 186. **II-V**, KOEFOED-PETERSEN, *Cat. des bas-reliefs*, pl. viii, pp. 11-12 [D] (as north wall). **III-V**, id. *Ægyptisk Billedhuggerkunst*, pl. 8; id. *Eg. Sculpture* (1951), pl. 8; (1962), pl. 10. Texts, MARIETTE, *Mastabas*, p. 177 [C].

(4) [1st ed. 3] Deceased at table, with [priests] and offering-bringers, and two registers, musicians and singers and sailing-boat.

MOGENSEN, *Mastaba*, pls. iii, v, figs. 6a, 7, 9; id. *Coll. ég.* pl. xc, p. 85; KOEFOED-PETERSEN, *Cat. des bas-reliefs*, pls. iv, v, pp. 9-10 [II]. Musicians and boat, id. *Stormandsgrav*, fig. 4; id. *Ægyptisk Billedhuggerkunst*, pl. 7; id. *Eg. Sculpture* (1951), pl. 7; (1962), pl. 9; musicians, HICKMANN, *Ägypten*, fig. on p. 24; singer and harpist on left, FRANCESCHI and JOHANSEN, *Et hundrede fire og tyve fotografier* (1969), pl. 11. Texts of musicians and boat, MARIETTE, *Mastabas*, pp. 176 [bottom]-177.

(5) [1st ed. 4] False-door.

MOGENSEN, *Mastaba*, pl. ii, fig. 5; id. *Coll. ég.* pl. lxxxvii [left], p. 84; KOEFOED-PETERSEN, *Stormandsgrav*, fig. 3; id. *Ægyptisk Billedhuggerkunst*, pl. 6; id. *Eg. Sculpture* (1951), pl. 6; (1962), pl. 8; id. *Cat. des bas-reliefs*, pls. i, iii, p. 8 [I]; KIELLAND, *Geometry in Egyptian Art*, fig. 28. Texts, MARIETTE, *Mastabas*, p. 176 [middle]. Name and title, DE ROUGÉ, *Inscr. hiéro.* pl. lxxxvii [bottom left].

(6) [1st ed. 5] Deceased at table, with [offering-bringers], and three registers, men bringing bulls and four rowing-boats.

MOGENSEN, *Mastaba*, pls. iv, vi, figs. 8, 10-13; id. *Coll. ég.* pl. lxxxix, p. 85; KOEFOED-PETERSEN, *Cat. des bas-reliefs*, pls. vi, vii, pp. 10-11 [III]. Right boat in bottom register, id. *Stormandsgrav*, fig. 7. Two short texts, MARIETTE, *Mastabas*, p. 176 [top].

(7) [1st ed. 6] Two bottom registers, I (partly lost), netting fish, II, herdsmen in canoes and cattle crossing water.

MOGENSEN, *Mastaba*, pl. i, figs. 3, 4; id. *Coll. ég.* pl. lxxxviii [lower], p. 85; KOEFOED-PETERSEN, *Stormandsgrav*, fig. 5; id. *Cat. des bas-reliefs*, pl. ix, pp. 12-13 [E]; POULSEN (F.), *Ægyptens Kunst* (1933), fig. 44; left part, WOLDERING, *Götter*, fig. on p. 230 [Kat. 46]. Fish in I, SCHMIDT, *Levende og Døde*, figs. 499, 500. II, KOEFOED-PETERSEN, *Det gamle Ægypten* (1943), fig. on p. 12; id. *Ægyptisk Billedhuggerkunst*, pl. 9; id. *Eg. Sculpture* (1951), pl. 9; (1962), pl. 11; boat on left, CAPART, *Documents*, ii, pl. 28. Longer text in II, MARIETTE, *Mastabas*, p. 175.

No. 80 (probably) [D 3; S 903]. RĒ'EMKA , King's eldest son of his body (probably of Isesi), Chief lector-priest, etc. End of Dyn. V.

Plan XLIX.

Usurped from Neferirtnes , Judge and Inspector of scribes, etc.

Chapel. In New York, M.M.A. 08.201.1.

MARIETTE, *Mastabas*, pp. 178-81, with plan on p. 178; HAYES, *Scepter*, i, pp. 94-102. View *in situ*, *A Handbook of the Egyptian Rooms* (1911), fig. 9.

(1) Doorway. (a) and (b) Registers, I, boat, II, men dragging statue, III, offering-bringers, IV, butchers.

(a) II-IV, CAPART, *Memphis*, fig. 319. Text in II, MARIETTE, *op. cit.* p. 178. (b) II-III (incomplete), showing unfinished part, RANSOM WILLIAMS, *The Decoration of the Tomb of Per-nēb*, pl. iv.

(2) Deceased and sons, and registers, I, female dancers and clappers, and men bringing cattle in II, wild animals in III, and fowl in IV, V, estates, VI, reaping corn, transport with donkeys, donkeys threshing, and stacking straw.

Left part of III-V, *A Handbook of the Egyptian Rooms* (1911), fig. 11. Some men with animals in III, PHILLIPS, *Ancient Egyptian Animals* (1948), fig. 10; A. M. L[YTHGOE] in *M.M.A. Bull.* iii (1908), fig. 5, p. 221. V, one estate, B. M. C[ARTLAND] in *ib.* xi (1916), fig. 7 on p. 167; names of estates, JACQUET-GORDON, *Domaines*, pp. 353-5 [15S5], *cf.* figs. 135-6. VI, HAYES, *op. cit.* fig. 57; overseer, B. M. C[ARTLAND], *op. cit.* fig. 3 on p. 167; man with laden donkey, MAZAR, *Views*, i, pl. 109; *I.L.N.* Sept. 16, 1950, fig. on p. 450 [near top left]; PHILLIPS, *op. cit.* fig. 9; donkeys threshing, *id. ib.* fig. 12. Texts, MARIETTE, *op. cit.* pp. 180-1 [D].

(3) Upper part, offering-list. Lower part, registers, I-II, hunting gazelles and ibexes with dogs and lasso, III-IV, rowing-boats.

Upper part. Last line of list, *id. ib.* p. 180 [top].

Lower part. HAYES, *op. cit.* fig. 56; *id.* in *M.M.A. Bull.* n.s. iv (March 1946), fig. on p. 173. I-II, *A Guide to the Collections*, i (1934), fig. on p. 5; right part, PHILLIPS, *op. cit.* figs. 11, 14. I-III, *Guide to the Collections. Egyptian Art* (1962), fig. 6. Man with ibex in II, *A Brief Guide to the Egyptian Collection* (1946), fig. on p. 7. Texts in III-IV, MARIETTE, *op. cit.* p. 180 [middle].

(4) False-door.

Texts, *id. ib.* p. 179; at back of niche, DE ROUGÉ, *Inscr. hiéro.* pl. xcvi [left]. Ancient

correction of figure of deceased, FISCHER in *J.N.E.S.* xviii (1959), fig. 10 [f], p. 245 note 28 [f]. Deceased, B. M. C[ARTLAND] in *M.M.A. Bull.* xi (1916), fig. 6 on p. 167.

(5) Deceased seated, with food-offerings, and registers, I-II, men bringing food, and roasting goose, III, butchers and cooking meat, IV, netting fowl.

Right part of I-III, *A Handbook of the Egyptian Rooms* (1911), fig. 10. IV, id. ib. fig. 12; HAYES, *Scepter*, i, fig. 55; omitting man on left, A. M. L[YTHGOE] in *M.M.A. Bull.* iii (1908), fig. 4, p. 221. Some short texts, MARIETTE, op. cit. pp. 178-9 [B].

(6) Remains of registers, I (lower part only), men tending cattle, including milking, II, man cutting out roes of fish, men bringing basket of fish, baking bread, III (much destroyed), offering-bringers, brewing beer.

HAYES, *Scepter*, i, fig. 54.

No. 81 [D 4]. ʿANKHIRIS , Sole companion. Dyn. V.

MARIETTE, *Mastabas*, p. 182, with plan of chapel.

Statuette of squatting female baker, in Cairo Mus. CG 108. BORCHARDT, *Statuen*, i, Bl. 24, pp. 84-5; MARIETTE, *Album du Musée de Boulaq* (1872), on pl. 20 [108]; MASPERO, *Guide* (1914), fig. 83, pp. 297-8 [3160]; (1915), fig. 26, p. 75 [173]; id. *Hist. anc.* i, fig. on p. 247 [lower]; id. *Égypte*, fig. 163; PERROT and CHIPIEZ, *Hist. de l'Art*, i, fig. 444; MEIER-GRAEFE, *Pyramide und Tempel*, Taf. 16; HORNEMANN, *Types*, iv, pl. 1002; ANGIOLETTI and BIGONGIARI, *Testimone*, Tav. 18; DAVIES MSS. photo. 1.856.

No. 82 [D 5; S 908]. MERESʿANKH , King's wife (perhaps of Isesi), etc. End. of Dyn. V.

Chapel. MARIETTE, *Mastabas*, pp. 182-3, with plan.

South wall. Remains of two painted registers (with guide-lines), harpists and female singers, clappers and dancers; see QUIBELL, *Saqqara (1907-1908)*, p. 24.

West wall. False-door; MARIETTE, op. cit. p. 183; inner jambs, DE ROUGÉ, *Inscr. hiéro.* pl. lxxvii [upper].

No. 83 [D 6; S 907]. KHENU , Overseer of linen (*sšrw*) and of fringed cloth (*sšt*) of the King, etc. Late Dyn. V or Dyn. VI.

Plan L.

MARIETTE, *Mastabas*, pp. 184-6, with plan of chapel.

Chapel.

(1) Remains of bottom registers of estates.

Names, id. ib. p. 186 [bottom]; JACQUET-GORDON, *Domaines*, pp. 350-1 [13S5], Nos. 13-20, cf. figs. 132, 133 [b].

(2) False-door (unfinished).

Texts and deceased, MARIETTE, op. cit. pp. 185-6 [C], fig. on pp. 465-7. Threat, SETHE, *Urk.* i. 34-5 [22]. Name and title, DE ROUGÉ, *Inscr. hiéro.* pl. cxix [middle].

(3) Remains of bottom register of estates.

Names, MARIETTE, op. cit. p. 185 [top]; JACQUET-GORDON, op. cit. pp. 349-50 [13S5], Nos. 1-12, cf. figs. 132, 133 [a]; first ten, MARIETTE in *Rev. Arch.* xix (1869), pl. iii [d] facing p. 82.

Statues of deceased. In Cairo Museum.

Seated, headless, CG 102. See BORCHARDT, *Statuen*, i, pp. 80-1 (text).

Seated, with papyrus on lap, CG 171. Id. ib. Bl. 38, pp. 120-1.

No. 84 [D 7; S 919]. KAEMTHENENT , King's son, Overseer of the expedition, etc. Temp. Isehi.

Plan L.

Wife, Khenut , Royal acquaintance.

MARIETTE, *Mastabas*, pp. 187-9, with plan of chapel.

Two inscribed blocks from jambs, exact position unknown, in Cairo Mus. Temp. Nos. 19.11.24.17, 19. See SMITH (W. S.) in REISNER, *Tomb Development*, p. 407.

I. Portico.

(1)-(2) Names and titles from architrave and pillars, MARIETTE, op. cit. p. 188 [top]; titles of deceased, SETHE, *Urk.* i. 180 [25 (116), Aa].

(3) and (4) [1st ed. 1, 2] (presumably) Remains of autobiographical text, mentioning Ra-shepses (tomb LS 16).

QUIBELL, *Saqqara (1907-1908)*, pl. lxi [3-5], pp. 82-7 (text by Spiegelberg); text, SETHE, op. cit. 181-6 [25 (116), B-E]; of Quibell's blocks, GUNN Notebook, 22, pp. 4, 6, 8; cf. BRUGSCH, *Hieroglyphisch-demotisches Wörterbuch*, iv, p. 1675 [top]. See MARIETTE, op. cit. p. 188 [middle].

II. Outer Hall.

(5) [1st ed. 3, 4] Doorway. (a) and (b) Deceased and wife.

Names and titles, id. ib. p. 188 [bottom]; titles of deceased, SETHE, op. cit. 181 [25 (116), Ab].

(6) [1st ed. 5] Remains of jambs of false-door.

Names and titles, MARIETTE, op. cit. p. 189; one title, SETHE, op. cit. 181 [25 (116), Ac].

No. 85 [D 8; S 910]. ISESI'ANKH , King's son, Overseer of all works of the King, Overseer of the expedition, etc. End of Dyn. V.

MARIETTE, *Mastabas*, pp. 189-91, with plan of chapel; QUIBELL, *Saqqara (1907-1908)*, pp. 24-5.

Remains of titles on architrave of portico, MARIETTE, op. cit. p. 190.

False-door. Id. ib. p. 191; some texts, DE ROUGÉ, *Inscr. hiéro.* pl. lxxxix [middle].

No. 88 [B 9]. HUTI , Inspector of scribes of the house of the master of the largesse, etc. Dyn. V-VI.

Wife, Kitsen , Royal acquaintance.

MARIETTE, *Mastabas*, p. 99, with plan.

Panel of false-door, in Cairo Mus. CG 1392. BORCHARDT, *Denkmäler*, i, Bl. 13, p. 53; PERROT and CHIPIEZ, *Hist. de l'Art*, i, fig. 455; VANDIER, *Manuel*, ii, fig. 282 [upper middle]; PETRIE GIZA photo. 543; GRIFFITH INST. photo. 346 [left]. Names, LIEBLEIN, *Dict.* No. 1416.

Statues, in Cairo Mus. (a) Deceased seated, CG 64; BORCHARDT, *Statuen*, i, Bl. 16, p. 56. (b) Wife seated, CG 48; id. ib. Bl. 12, pp. 43-4.

OTHER NUMBERED OLD KINGDOM TOMBS

(a) MARIETTE

B 2. HETEPHERES , Prophetess of Neith, Hathor Mistress of the Sycamore, and Khufu, etc. Dyn. IV.

False-door. MARIETTE, *Mastabas*, pp. 90-1.

B 3. SHERY , Overseer of *warb*-priests of Peribsen, and *ka*-servants of Send, in the Necropolis, etc. Dyn. IV.

Wife (almost certainly), Khentetka  *mitrt*.

Monuments, MORET in *Mon. Piot*, xxv (1921-2), pp. 273-98, with pls. xxi, xxii, figs. 1, 2, 4, 7. See WEILL, *La II^e et la III^e dynasties*, pp. 330-3.

False-door, lower part, in Cairo Mus. CG 1384. MARIETTE, *Mastabas*, pp. 92-4; MASPERO, *Hist. anc.* i, fig. on p. 237; id. *Égypte*, fig. 50; AMÉLINEAU, *Les Nouvelles Fouilles d'Abydos (1897-1898)*, i, pl. xx [10]; ii, pp. 500-1, 677; BORCHARDT, *Denkmäler*, i, Bl. 10, pp. 42-4; VANDIER, *Manuel*, ii, fig. 279 [upper left]. Upper parts of thicknesses, PETRIE Gîza photo. 546. Text of lintel, GRDSELOFF in *Ann. Serv.* xlv (1944), p. 294; of left jamb, WILDUNG, *Die Rolle äg. Könige*, i, Abb. iii [2], pp. 47-8 [Dok. xiii. 10]. See MASPERO, *Guide*, p. 45 [82]; SCHIAPARELLI, *Mus. Arch. Firenze*, pp. 230 note 1, 231 note 1.

Panel, deceased and wife at table, in Oxford, Ashmolean Mus. 1836.479. *Marmora Oxoniensia* (1763), Pt. ii, pl. i [v*]; GORDON, *Twenty-five Plates*, pl. vi [upper]; LEPSIUS, *Auswahl*, Taf. ix [upper]; MEYER, *Geschichte des alten Aegyptens* (1887), Pt. 2, fig. on p. 93; *A Summary Guide* (1951), pl. lxiv [B], p. 72; MOOREY in *Oxford Magazine*, Nov. 7, 1969, pl. iii, p. 48; id. *Ancient Egypt*, pl. 2; WILLIAMS rubbings, iv. 106. See *A Catalogue of the Ashmolean Museum* (1836), p. 145 [479]; CHESTER, *Catalogue of the Egyptian Antiquities in the Ashmolean Museum, Oxford* (1881), pp. 47-8 [794].

Panel, deceased and wife at table, in Florence Mus. 2554. PETRIE ITAL. photos. 1. Text, BEREND, *Principaux monuments*, p. 61; SCHIAPARELLI, *Mus. Arch. Firenze*, pp. 230-2 [1534]. Names and titles, LIEBLEIN, *Dict.* No. 1357.

Two blocks, deceased (no name) with children, followed by son Iasen  and offering-bringer, in Aix-en-Provence, Musée Granet, 1, 2. MILLIN, *Voyage dans les Départements du Midi, Atlas*, pl. xlv [2, 3], cf. vol. iii, pp. 347-8. Texts, WIEDEMANN in *P.S.B.A.* ix (1887), p. 180. See DEVÉRIA in GIBERT, *Musée d'Aix*, i (1882), pp. 7-8 (repr. in *Bibl. Ég.* iv, pp. 225-7); AUDE, *Le Musée d'Aix-en-Provence* (1921), p. 9.

Block with two registers, man, and deceased seated, in Brit. Mus. 1192. *Guide, Eg. Collns.* (1909), fig. on p. 192; (1930), fig. 155, p. 286; *Hiero. Texts*, i, pl. 3 [1]; i², pl. xiii [3], pp. 13-14.

B 7. SETHU [II] , Judge and Overseer of scribes, etc. Dyn. IV(?).

Wife, Hathornüfer .

MARIETTE, *Mastabas*, pp. 97-8, with plan of chapel.

Two palace-façade false-doors, in Cairo Mus. CG 1377-8. BORCHARDT, *Denkmäler*, i, Bl. 8, pp. 35-6; see MASPERO, *Guide* (1914), p. 68 [174-5] with fig. 4; (1915), p. 79 [177-8] with fig. 7 (in both editions CG 1377). CG 1377, id. ib. (1883), p. 209 [883] with pl. facing p. 33; id. *Égypte*, fig. 44; id. *Hist. anc.* i, fig. on p. 316; CAPART, *L'Art ég.* (1909), pl. 29; id. id. i, pl. 29; VANDIER, *Manuel*, ii, fig. 272 [lower right]. CG 1378, VON BISSING, *Denk-*

mäler, Text to Taf. 17 [fig. 1]. One, PERROT and CHIPIEZ, *Hist. de l'Art*, i, figs. 291-2 (adapted).

Two offering-stands, in Cairo Mus. CG 1298, 1301. BORCHARDT, *Denkmäler*, i, Bl. 1 (CG 1298), pp. 2-3, 4; MARIETTE, *Album du Musée de Boulaq* (1872), pl. 11.

Block, deceased and wife, and offering-bringers and estates below, in Cairo Mus. CG 1494. BORCHARDT, *Denkmäler*, i, Bl. 43, pp. 199-200; names of estates, JACQUET-GORDON, *Domaines*, p. 410 [34S6], cf. fig. 170; names and titles, LIEBLEIN, *Dict.* No. 1377.

B 15. WERKAPTAḤ , Overseer of the granary, etc. Middle Dyn. V or later.

MARIETTE, *Mastabas*, p. 108, with plan of chapel.

Lower part of false-door. Texts, id. ib. p. 108.

D 70 [LS 15]. PEḤNUIKA , Chief Justice and Vizier, Inspector of *wac*b-priests in the Pyramid of Userkaf, etc. Middle Dyn. V or later.

Wife, Hetepheres .

Plan XLIX.

L. *D. Text*, i, pp. 162-5. Plan, MARIETTE, *Mastabas*, pp. 370-2. Plans and section of west part, L. *D.* i. 38, *Text*, i, figs. on pp. 162-3. View, MARIETTE, *Voyage*, i, pl. 12, p. 42.

West Part.

Room I.

(1) [1st ed. 1, 2] Doorway. (a) Registers, I, sailing-boat, II-III, sailors, in Berlin (East) Mus. 1131. (b) Similar to (a), with boat with sail furled being rowed. (c) Drum with name and titles.

(a) L. *D.* ii. 45 [b]; *Aeg. und Vorderasiat. Alterthümer*, Taf. 3. Boat in I, DÜMICHEN, *Flotte*, Taf. xxvi; BORCHARDT, *Das Grabdenkmal des Königs S'azhu-rc*, ii, Abb. 24 on p. 165. II-III, FECHHEIMER, *Plastik* (1914), Taf. 117; (1923), Taf. 127. II, RANKE, *The Art of Ancient Egypt*, and BREASTED, *Geschichte Aegyptens* (1936), 205; incomplete, SCHÄFER, *Von äg. Kunst* (1919), Taf. 20 [1]; (1922 and 1930), Taf. 19 [1]; (1963), Taf. 18 [1]; Eng. ed. *Principles of Egyptian Art*, pl. 30. III (incomplete), HAMANN, *Äg. Kunst*, Abb. 155; BARTA, *Das Selbstzeugnis eines altägyptischen Künstlers*, Taf. xxiv [38]. Texts, *Aeg. Inschr.* i, p. 13. See *Ausf. Verz.* p. 55; *Führer* (1961), p. 44.

(b) L. *D.* ii. 45 [a]; DÜMICHEN, op. cit. Taf. xxv [8].



(c) L. *D. Text*, i, p. 162 [middle].

(2) [1st ed. 3, 4] (a) and (b) Lower register, deceased (much destroyed at (a)).

L. *D. Ergänz.* xlvii [b].

(3) [1st ed. 5] Deceased seated, with dog under chair, and wife squatting, with registers, I, [perhaps ploughing], II, reaping corn, III, bringing donkeys and transport of grain, IV, winnowing, and threshing with cattle and donkeys, V, estates.

L. *D.* ii. 47. Names of estates, JACQUET-GORDON, *Domaines*, pp. 366-9 [18S5], Nos. 1-28, cf. figs. 141, 142 [a].

(4) [Part of 1st ed. 6] Deceased and Zefatsen  (mother?) with son Iti , and registers, I, [animals], II, animals from hunting-scene (block in Berlin (East) Mus. 1132,

and another, probably adjoining on right, in Brooklyn Mus. 64.147), III, men bringing animals, IV, netting fowl, V-VI, son and officials, netting fish, and men cutting out roes of fish, VII, estates.

L. D. ii. 46 [left and middle]. Berlin (East) Mus. 1132, WRESZ., *Atlas*, i. 382 [A]; iii. 103; FECHHEIMER, *Plastik* (1914), Taf. 118; (1923), Taf. 128; MAT'É, *Iskusstvo Drevnego Egipta* (1961), fig. 57; Leningrad. *Vystavka proizvedenii iskusstva iz muzeev Germanskoi Demokraticheskoi Respubliki. Katalog* (1958), 90th pl.; KEIMER in *Egypt Trav. Mag.* No. 8 (March 1955), fig. on p. 8 [lower]; PIRENNE, *Hist. civ.* i, pl. 61 [lower] facing p. 188; BOTHMER in *Festschrift Ägyptisches Museum Berlin* (1974), Taf. 7 [a], pp. 67-9; part, PRIOÁN, *Summa Artis*, iii (1945), fig. 203; see *Ausf. Verz.* p. 55; *Führer* (1961), p. 44. Brooklyn Mus. 64.147, BOTHMER, op. cit. Taf. 7 [b], pp. 67-9; see *The Brooklyn Museum Annual*, vi (1964-5), p. 63. Men extracting roes, see KEIMER in *Bull. Inst. Ég.* xxi (1938-9), pp. 220-1 [2] with pl. ii [right] (from LEPSIUS). Names of estates, JACQUET-GORDON, *Domaines*, pp. 366, 369-70 [1885], Nos. 29-56, cf. figs. 141, 142 [b].

(5) [Part of 1st ed. 6] False-door, with threat to people entering in impure state.

L. D. ii. 46 [right]. Text, SETHE, *Urk.* i. 48-9 [30, A, B].

Room II.

(6) [1st ed. 7, 8] (a) and (b) Two registers, men bringing animals.

L. D. ii. 45 [c, d].

(7) [1st ed. 9] Blocks from jamb, butchers slaughtering oryx, in Berlin (East) Mus. 1133, and two offering-bringers, formerly in Berlin Mus. 1134, now in Gotha, Schlossmuseum, 74 Ae.

See L. D. *Text*, i, p. 164; *Ausf. Verz.* p. 55. Texts of Berlin (East) Mus. 1133, *Aeg. Inschr.* i, pp. 12-13. Gotha 74 Ae, see SCHENK ZU SCHWEINSBERG, *Kurze Übersicht* (1935), Section 24; WENIG, *Ägyptische Sammlung (Museen der Stadt Gotha. Schlossmuseum Schloss Friedenstein)*, No. 2.



(8) [1st ed. 10] False-door (destroyed). Lower part of right jamb, in Berlin (East) Mus. 1120.



L. D. ii. 48, details, i. 41 [bottom]. Berlin (East) Mus. 1120; texts, *Aeg. Inschr.* i, p. 14; see *Ausf. Verz.* p. 59.

H 12. KHUIT   e, King's sole adorer (woman). Dyn. V-VI.

False-door, in Cairo Mus. CG 1448. Texts, BORCHARDT, *Denkmäler*, i, pp. 132-3. Drum. Name and title, MARIETTE, *Mastabas*, p. 450.

(b) LEPSIUS

LS 5. SESHEMU   , Treasurer of the God in the two boats, Overseer of the expedition, Prophet of Rēc in the Sun-temple of Neferirkarēc, etc. Middle Dyn. V or later.



Wife, Mertiotēs   , Prophetess of Ḥathor Mistress of the Sycamore, etc.

L. D. *Text*, i, p. 142, with plan of chapel.

False-door, and right of it, deceased (head, in Berlin Mus. 1110). L. D. ii. 97 [a]; text of Berlin Mus. 1110, *Aeg. Inschr.* i, p. 25; see *Ausf. Verz.* p. 57.

LS 6. METHEN , Chief of various Great Estates (mainly in the Delta), Chief of a funerary estate of Snefru in the Letopolite nome, Director of *wab*-priests, etc. Early Dyn. IV.

Plan XLIX.

Parents, Inpuemankh , Judge and Scribe, and Nebsent .

L. D. Text, i, pp. 142-4. Plan of chapel, id. ib. p. 142; *Aeg. Inschr.* i, p. 73; with sections, L. D. i. 38. Texts, *Aeg. Inschr.* i, pp. 73-87; see GÖDECKEN, *Eine Betrachtung der Inschriften des Meten* [etc.]. Titles, GOEDICKE in *Mitt. Kairo*, 21 (1966), pp. 1-62; MASPERO, *La Carrière administrative* [etc.] in *Études Égyptiennes*, ii, pp. 115-246; SETHE, *Urk.* i. 5-7 [I, E, F]. Details of hieroglyphs, DAVIES MSS. 2.108.1-3.

Chapel. In Berlin (East) Mus. 1105. See *Ausf. Verz.* pp. 45-8.

(1) [1st ed. 1-7; *Aeg. Inschr.* A-D] Doorway with passage. (a)-(b) Remains of lintel with titles; (c) drum with name and titles; (d) and (e) biographical texts, and three offering-bringers.

(a)-(c) L. D. ii. 7 [a]; GOEDICKE, op. cit. Taf. ii. (d) L. D. ii. 6 [left], 7 [b]; GOEDICKE, op. cit. Taf. iii, pp. 64-5; text, SETHE, *Urk.* i. 3-5 [I, C]; omitting titles, GOEDICKE, *Rechtsinschriften*, Taf. ii, pp. 8-17 [B]; names of estates, JACQUET-GORDON, *Domaines*, pp. 322-3 [1S4], Nos. 1-3, cf. figs. 108, 109 [a]. (e) L. D. ii. 5 [right], 7 [c]; GOEDICKE in *Mitt. Kairo*, 21 (1966), Taf. iv, pp. 65-6; text, SETHE, *Urk.* i. 2-3 [I, B]; omitting titles, GOEDICKE, *Rechtsinschriften*, Taf. i [a], pp. 6-8 [A]; columns 1-6, JONCKHEERE, *Les Médecins de l'Égypte pharaonique*, fig. 11, p. 46.

(2) [1st ed. 9; *Aeg. Inschr.* M] Register of attendants bringing various articles, and deceased, with two men bringing young antelope and gazelle.

L. D. ii. 4 [right]. Titles of deceased, GOEDICKE in *Mitt. Kairo*, 21 (1966), Taf. ix [upper]; three hieroglyphic signs, VON GYNZ-REKOWSKI in *Klio*, 50 (1968), Abb. 5, p. 14; hare-hieroglyph, HAMANN, *Tierplastik im Wandel der Zeiten*, Taf. 10; LANGE, *Ägyptische Tierplastik*, Abb. 4; EKSCHEMITT, *Das Gedächtnis der Völker*, Abb. on p. 86 [lower]; WOLF in *Antike und Universalgeschichte* (Festschrift . . . Stier, 1972), Taf. 6 [10].

(3) [1st ed. 8; *Aeg. Inschr.* N] Registers, butchers (unfinished), attendants, and deceased with priests.

L. D. ii. 4 [left]. Butchers, FISCHER in *Orientalia*, n.s. 29 (1960), pl. xlviii [iii], p. 181 [1]. Deceased with priests, HASSAN, *Giza*, iv, fig. 34. Titles of deceased, GOEDICKE in *Mitt. Kairo*, 21 (1966), Taf. ix [lower].

(4) [1st ed. 10; *Aeg. Inschr.* K] Deceased seated with priests before him, and below, I, attendants, II-III, ibexes and antelopes, IV-VI, dogs bringing down ibex, gazelle, and antelope.

L. D. ii. 6 [middle]. Deceased, CLÉDAT in *Rev. Arch.* 3 Sér. xxxiii (1898), fig. 1 on p. 15. Priest kneeling, MÜLLER (H.) in *Mitt. Kairo*, 7 (1937), Abb. 17 on p. 79. II-III, WEIGALL, *Anc. Eg. . . . Art*, 20 [lower]; FECHHEIMER, *Plastik* (1914), Taf. 107; (1923), Taf. 117; SCHÄFER and ANDRAE, *Kunst* (1925), 237 [lower]; (1930 and 1942), 249 [lower]; DEMEL, *Die Reliefs der Kultkammer des Kaninisut* [etc.] in *Jahrbuch der Kunsthistorischen Sammlungen in Wien*, n.f. iii (1929), Abb. 18 on p. 23; PIJOÁN, *Summa Artis*, iii (1945), fig. 111. III, RANKE, *The Art of Ancient Egypt*, and BREADED, *Geschichte Aegyptens* (1936), 184; BYVANCK, *De Kunst*, pl. xxiii [83]; WOLF, *Kunst*, Abb. 168.

(5) [1st ed. 14; *Aeg. Inschr.* L] Deceased with two priests before him, and four estates below.

L. D. ii. 5 [middle]. Deceased and priests, CAPART, *Memphis*, fig. 185.

(6) [1st ed. 11-13, 15-17; *Aeg. Inschr.* E-] False-door. All faces, deceased, with small animals before him at (a) and man libating at (b), and at table on panel.

L. D. ii. 3, 5 [left], 6 [right]; GOEDICKE in *Mitt. Kairo*, 21 (1966), Taf. i, v-viii, pp. 66-7; inner part, HAMANN, *Äg. Kunst*, Abb. 124; (i) FECHHEIMER, *Plastik* (1914), Taf. 106; (1923), Taf. 116. Text above door, and at (c), SETHE, *Urk.* i. 1-2 [1, A], 5 [1, D]; above door (omitting titles), GOEDICKE, *Rechtsinschriften*, Taf. i [b], pp. 17-20 [C]. Offering-list on panel, see HASSAN, *Giza*, v, pp. 103-6 with fig. 17. Hieroglyph of hunter, from (a), CAPART, *Memphis*, fig. 257 (reversed). Titles at (b), id. ib. fig. 187. Head of deceased, L. D. iii. 288 [2].

Serdab.

Statue of deceased seated, granite, in Berlin (West) Mus. 1106. L. D. ii. 120 [a-e], iii. 288 [1]; *Aeg. und Vorderasiat. Alterthümer*, Taf. 8 [right]; *Ausf. Verz.* Abb. 4 on p. 47, cf. p. 66; FECHHEIMER, *Kleinplastik der Ägypter*, Taf. 6, 7; VON BISSING, *Äg. Kunstgeschichte*, Taf. lxiv [393], *Text*, i, p. 39; SCHARF in OTTO, *Handbuch der Archäologie*, i, Taf. 72 [2], p. 512; ERMAN, *Die Welt am Nil*, Taf. 17 [right]; id. *L'Égypte des pharaons*, pl. v [b]; ANTHES, *Meisterwerke*, Taf. i; id. *Aeg. Plastik*, Taf. 1; WOLF, *Die Welt der Ägypter*, Taf. 11; id. *Kunst*, Abb. 96; id. in *Antike und Universalgeschichte* (Festschrift . . . Stier, 1972), Taf. 3 [6]; *Sculptures et textes*, fig. on p. 71; SMITH, *Hist. Eg. Sculp.* pl. 4 [b], p. 18; HORNEMANN, *Types*, iii, pl. 751; KAISER, *Äg. Mus. Berlin* (1967), pp. 23-4 [222] with Abb. Texts, *Aeg. Inschr.* i, p. 68.

LS 14. KAIEMKED , Overseer of the Treasury, Prophet of Rē in the Sun-temple of Neferirkarē, etc. Middle Dyn. V or later.

Wife, Nubka , Royal acquaintance.

L. D. *Text*, i, p. 162, with plan of north room.

Upper part of false-door. L. D. ii. 100 [c].

LS 16 [S 902]. RAŠSHEPSES , Chief Justice and Vizier (of Isesi), Overseer of Upper Egypt, etc. Temp. Isesi.

Plan XLIX.

Parents (probably), Neteruser (tomb, No. 78 [D 1]) and Khenut. Wife, Kaennebti .

Re-used in New Kingdom and later. 'Tombe du Defterdar' (Champollion).

L. D. *Text*, i, pp. 165-70; QUIBELL, *Saqqara* (1907-1908), pp. 23-4. Plan and sections of chapel, L. D. i. 39, *Text*, i, figs. on pp. 165, 167; PRISSE, *L'Art ég.* i, *Architecture*, 7th pl. 'Tombeaux . . . Memphis' [iii], *Texte*, p. 351. Plan of west part, NESTOR L'HÔTE MSS. 20396, 325. Description and drum with titles, BURTON MSS. 25618, 38-40; false-door, and scenes of hippopotamus-hunt, offering-bringers, winnowing, milking, bringing bull, and papyrus-gathering, possibly from this tomb, 25621, 95-103, 142. Titles and sketches, WILKINSON MSS. on vii. 48; ix. 117 [near bottom]. Vases, PRISSE, *L'Art ég.* ii, *Art Industrielle*, 72nd pl. 'Choix de vases contemporains des pyramides' [3-5], *Texte*, p. 430.

I. Forecourt.

(1) Deceased and son Neteruser in canoe, with men with birds behind, and two registers below, men transporting calf and birds in canoes, and herdsmen in canoes with cattle crossing water.

L. D. ii. 60 [right]. Registers, DÜMICHEN, *Flotte*, Taf. xxv [10].

(2) Deceased in canoe fowling, with son Neteruser and wife, men with birds behind, and herdsman with cattle crossing water.

L. D. ii. 60 [left].

II. Hall.

(3) [1st ed. 3-5] (a) and (b) Deceased with son Neteruser; (c) five registers, bringing animals and overthrowing bull.

L. D. *Ergänz.* xli.

(4) [1st ed. 6] Four registers of offering-bringers. Id. ib. xxxix [b].

(5) [1st ed. 7] Four registers of bringing animals, etc. Id. ib. xxxix [c].

(6) [1st ed. 8-9] Upper part, deceased with son Neteruser watching [building boats]. Lower part, deceased, and registers with scribes, men bringing cattle, wild animals and fowl, and estates.

L. D. ii. 61 [b]. Names of estates, JACQUET-GORDON, *Domaines*, pp. 371-2 [1955], cf. figs. 143-4.

(7)-(8) [1st ed. 12-13] Upper part, deceased seated and four registers of [vintage-scenes] and men bringing fruit, and picking figs (above doorway). Lower part, deceased seated and four registers of food-offerings, men bringing offerings, female dancers and clappers, musicians, and men playing draughts and *mehen*-game.

L. D. ii. 61 [a]. Men playing *mehen*-game, WILKINSON, *M. and C.* (ed. BIRCH), ii, fig. on p. 61 (No. 323).

III. Serdab. Intrusive burials.

Inscribed mummy-cartonnage, from mummy of child, in Berlin (East) Mus. 13149. L. D. *Text*, i, fig. 1 on p. 169, cf. p. 168 [top].

IV. Pillared Hall. [1st ed. VI]

(9) [1st ed. 10, 11, 14-17] Doorway. (a)-(b) Above doorway, [catching fowl], jambs, five registers of men bringing animals; (c) and (d) two boats at each, much destroyed at (c); (e) and (f) men dragging statues at each, with sub-registers of food-offerings.

(a)-(b) L. D. *Ergänz.* xxxix [a]. (c)-(f) L. D. ii. 64 bis.

(10) [1st ed. 18] Deceased and son Neteruser followed by attendants, and registers, I, offering-bringers, II-IV, men tending cattle, and boats, V, scribes, and Overseers and Directors of the gangs rendering accounts.

L. D. ii. 62, 63 [left]. Deceased and son, PRISSE, *L'Art ég.* ii, *Dessin*, 1st pl. 'Ancien canon' [etc.] [I], *Texte*, pp. 393-4. Three boats in III and IV, DÜMICHEN, *Flotte*, Taf. xxvii [1-3].

(11) [1st ed. 19] Deceased seated, with son, and five registers, scribes, and officials of estates rendering accounts.

L. D. ii. 63 [right], 64 [a]. Two prostrate officials, BURTON MSS. 25618, 38, 41. Sketch-plan of prostrate officials, NESTOR L'HÔTE MSS. 20396, 326.

(12) [1st ed. 20-1] (a)-(b) Above niches, food-offerings. Jambs between niches, three registers, offering-bringers and butchers.

L. D. *Ergänz.* xlii. Two titles on left jamb, CHAMP., *Not. descr.* ii, p. 485 [bottom middle]; NESTOR L'HÔTE MSS. 20396, 325 verso.

Pillars. Faces (a)-(c) and architrave above, names and titles; L. D. ii. 64 [b]; texts of (a) and architrave, CHAMP., *Not. descr.* ii, pp. 485 [left], 486 [top]. (d)-(e) Architrave with name and titles, id. ib. p. 485 [A].

VII. Corridor. See QUIBELL, *Saqqara (1907-1908)*, p. 23.

(13) [1st ed. 22-3] Registers, I, rams treading grain, ploughing, deceased in palanquin, scribes, men putting necklaces in boxes, II, flax-harvest, III, corn-harvest.

Some texts, MONTET, *Scènes*, pp. 197 [2 and bottom], 202 [bottom], 203 [3], 208 [3], 212 [lower, 1], 213 [6], 214 [2], 218 [5].

Exact position unknown. Inspection of linen and pottery-making; text of men heating ovens, id. ib. p. 237 [2]; of potters, 248 [2]; of men playing *mehen*-game, 374 [2].

Open court south-east of tomb.

Doorway in north-east corner. On both sides, deceased with son, and two copies of letter of Isesi; one, QUIBELL, op. cit. pl. lxi [2], p. 24; text, SPIEGELBERG in ib. pp. 79-80, cf. 81-2; SETHE, *Urk.* i. 179-80 [24 (115)]; GUNN Notebook, 22, pp. 1-2.

Serdab. Entered from Corridor VII.

Base of statue of deceased, in Cairo Mus. Temp. No. 23.7.17.17. Name and title, QUIBELL, op. cit. p. 23.

Head of wooden statue, probably of deceased, in Cairo Mus. JE 40037. Id. ib. pl. lx, p. 23; SPRINGER, *Die Kunst des Altertums* (1923), Abb. 63; PIRENNE, *Hist. civ.* i, pl. vi facing p. 196; SMITH (J. L.), *Tombs, Temples, and Ancient Art*, pl. facing p. 64 (painting); Brussels. *5000 ans*, Addenda, No. 12A with fig. 98; Stockholm. *5000 år*, Kat. 33 with fig.; Essen. *5000 Jahre*, No. 36 with Abb.; Amsterdam. *5000 jaar*, fig. 7 [23]; GRIFFITH INST. photo. 316; see MASPERO, *Guide*, p. 51 [98].

(c) QUIBELL

S 906. NEKHENSU , Lector-priest, Tenant of the Pyramid of Teti, etc. Dyn. VI.

South false-door, in Cairo Mus. JE 39865. QUIBELL, *Saqqara (1907-1908)*, pl. lxi [1], pp. 24, 115.

S 909. HEKNUNEBTI , King's daughter, King's sole adorer, etc. Probably Dyn. V.

Block, deceased seated, in Cairo Mus. JE 45239. Name, QUIBELL, *Saqqara (1907-1908)*, p. 24.

Drum, probably from here, in Cairo Mus. CG 1396. BORCHARDT, *Denkmäler*, i, Bl. 14, p. 56.

S 911. HEMAKHTI , Royal chamberlain. Dyn. V-VI.

Name and title from drum of south false-door, MARIETTE, *Mastabas*, p. 457 [H 14]; name, QUIBELL, *Saqqara (1907-1908)*, p. 25.

S 912. HARWĒR , Judge and Inspector of scribes. Dyn. V-VI.

Name and title from lintel, id. ib. p. 25.

S 913. PERNEB , Secretary of the Toilet-house, Director of the Palace, etc. End of Dyn. V.

Plan L.

Parents (probably), Ra'shepses and Kaennebti (tomb, LS 16).

LYTHGOE and RANSOM WILLIAMS, *The Tomb of Perneb*; RANSOM WILLIAMS, *The Decoration of the Tomb of Per-nēb*, with pls. vi et seq.; A. M. L[YTHGOE] in *M.M.A. Bull.* xi (1916), pp. 31-6, with views; HAYES, *Scepter*, i, pp. 90-4; QUIBELL, *Saqqara (1907-1908)*, p. 25; id. in *Egypt Exploration Fund. Archaeological Report 1907-1908*, p. 14 [g]. Plan and section, LYTHGOE and RANSOM WILLIAMS, figs. 3, 4. Views, id. ib. figs. 6-10, 12, 13; ΠΙΟΑΝ, *Summa Artis*, iii (1945), fig. 188; CID PRIEGO, *El Arte Egipcio*, 3rd pl. after p. 60 [upper]; in museum, *A Guide to the Collections*, i, fig. on p. 4; *M.M.A. Bull.* xi (1916), fig. on p. 77.



Chapel. In New York, *M.M.A.* 13.183.3.

Masons' graffito mentioning deceased, LYTHGOE and RANSOM WILLIAMS, fig. 32; Isesi'ankh (tomb, No. 85 [D 8]), see p. 55.

I. Vestibule.

(1) Doorway. (a) and (b) Deceased; (c) drum with name and titles.

(a) and (b) Id. ib. figs. 30-1; *Guide to the Collections. Egyptian Art* (1962), fig. 5. (a) B. M. C[ARTLAND] in *M.M.A. Bull.* xi (1916), fig. 5, p. 167. (b) HAYES, *Scepter*, i, fig. 50. (c) LYTHGOE and RANSOM WILLIAMS, fig. 33. Isolated hieroglyphs on left-hand wall of passage, FISCHER in *Metropolitan Museum Journal*, 9 (1974), fig. 6, p. 9.

(2) (preliminary sketch) Deceased in palanquin, and registers, **I**, man with oryx, **II**, man with bull, **III**, wife (no name) and sons Neteruser  and Ra'shepses , **IV**, steward and scribes, **V**, attendants and men with bull.

LYTHGOE and RANSOM WILLIAMS, fig. 34; RANSOM WILLIAMS, pl. vi; HAYES, *Scepter*, i, fig. 51. Deceased and **II-IV**, SCOTT in *M.M.A. Bull.* n.s. xxiv (Dec. 1965), fig. 48 on p. 148.

II. Offering-room.

(3) Doorway. (a) and (b) (preliminary sketches) Two registers of estates.

RANSOM WILLIAMS, pls. vii, viii. Names of estates, JACQUET-GORDON, *Domaines*, pp. 375-6 [21S5], Nos. 1-16, cf. figs. 147-8.

(4) Food-offerings, and men with animals and butchers below.

Parts, RANSOM WILLIAMS, pls. xviii, xix. Flower bowl, WINLOCK, *An Egyptian Flower Bowl in Metropolitan Museum Studies*, v (1936), fig. 8 [lower] on p. 153. See LYTHGOE and RANSOM WILLIAMS, p. 70.

(5) and (6) Deceased at table, with offering-list, offerings, priests and offering-bringers.

Parts of (5), RANSOM WILLIAMS, pls. xiv-xvii; one offering-bringer, B. M. C[ARTLAND] in *M.M.A. Bull.* xi (1916), fig. 4, p. 167. (6) LYTHGOE and RANSOM WILLIAMS, figs. 36-7; CAPART, *Memphis*, fig. 346; incomplete, *Guide to the Collections. Egyptian Art* (1962), fig. 8; left part, HAYES, *Scepter*, i, fig. 52; id. in *M.M.A. Bull.* n.s. iv (March 1946), fig. on p. 172; priests and some offering-bringers, GOUDSMIT in *Expedition. The Magazine of Archaeology/Anthropology*, 14 [4] (Summer 1972), figs. on p. 13; details, RANSOM WILLIAMS, pls. ix-xiii; two flower bowls, WINLOCK, op. cit. fig. 8 [upper] on p. 153.

(7) False-door.

LYTHGOE and RANSOM WILLIAMS, fig. 35; HAYES, *Scepter*, i, fig. 53.

Serdab.

Fragments of wooden statues, in New York, M.M.A. 14.7.105-7. See *M.M.A. Bull.* x (1915), p. 16.

Statue of deceased, probably from here, in Groppi Collection.

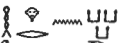
S 915. NIKAUHOR , Prophet of Rē^c in the Sun-temple of Userkaf, Prophet of Userkaf, etc. Probably late Dyn. V.

Wife, Sekhemhat^{or} , Prophetess of Ḥath^{or} Mistress of the Sycamore and Neith North of her Wall, etc.

See QUIBELL, *Saqqara* (1907-1908), p. 25; HAYES, *Scepter*, i, pp. 102-3.

Offering-room.

East wall, painted. North part, netting fish, cutting out roes and preparing botargo; QUIBELL, op. cit. pl. lxii [1]. South part, three registers, games, donkeys, etc., donkeys grazing, issuing grain; id. ib. pl. lxii [2].

South wall, painted with guide-lines. Female dancers and clappers; id. ib. pl. lxvi [1].

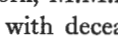
West wall, in New York, M.M.A. 08.201.2. From left, remains of registers of offering-bringers, 1st false-door with deceased and small sons Kanūfer  and Nikauhor on jambs, three registers, I, playing draughts (*senet*), musicians and singers, II, offering-bringers, III, butchers, 2nd false-door, and remains of registers of offering-bringers (painted).

Id. ib. pls. lxiii-lxv, lxvi [3, 4]; *A Handbook of the Egyptian Rooms* (1911), fig. 15. Deceased and son, on left jamb of first false-door, The Metropolitan Museum of Art. Miniatures. Album T. *The Life and Civilization of Egypt* (1950), 2nd fig.; on right jamb, HAYES in *M.M.A. Bull.* n.s. iv (March 1946), fig. on p. 175, cf. p. 176; head of deceased on left jamb, FISCHER in *Ĵ.N.E.S.* xviii (1959), pl. ix [B], p. 239; I, HAYES, *Scepter*, i, fig. 59; incomplete, id. in *M.M.A. Bull.* n.s. iv (March 1946), figs. on p. 174, cf. p. 176; draughts-players, WINLOCK, *The Private Life of the Ancient Egyptians*, fig. 18; SPIEGEL, *Hochkultur*, Taf. 53 [a]; omitting text, PIEPER, *Das Brettspiel der alten Ägypter* [etc.] (Wissenschaftliche Beilage zum Jahresbericht des Königstädtischen Realgymnasiums zu Berlin, 1909), Abb. 2; with singer and harpist, *A Handbook of the Egyptian Rooms* (1911), fig. 16; musicians and singers with upper parts of offering-bringers in II, HICKMANN, *Ägypten*, Abb. 55; id. in *Orientalische Musik*, Taf. iii; singer and flutist, MAZAR, *Views*, ii, pl. 190 [upper]. Wife at table, from panel of 2nd false-door, LANSING in *M.M.A. Bull.* n.s. i (May 1943), fig. on p. 268 [upper]; deceased and wife, from left jamb, HAYES, *Scepter*, i, fig. 58; *Guide to the Collections. Egyptian Art* (1962), fig. 7; upper parts, *A Brief Guide to the Egyptian Collection* (1946), fig. on p. 4. Offering-bringers at north end, RANSOM WILLIAMS, *The Decoration of the Tomb of Per-nēb*, pl. iii.

North wall (painted). Remains of mat-making and baking cakes; QUIBELL, *Saqqara* (1907-1908), pl. lxvi [2].

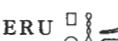
S 916. PTAḤMA^cKHERU , Prophet of Rē^c and Ḥath^{or} in the Sun-temple of Neferirkarē^c, Prophet of Rē^c in the Sun-temple of Neuserre^c, etc. End of Dyn. V or later.

False-door. Texts, QUIBELL, *Saqqara* (1907-1908), p. 26.

Offering-table with long offering-list, alabaster, in Berlin (East) Mus. 1159. SEYFFARTH MSS. iii. 2650-6, No. 5; part with offering-text, WILLIAMS rubbings, iv. 68 [lower]; text, *Aeg. Inschr.* i, pp. 54-8; see *Ausf. Verz.* p. 64; *Führer* (1961), p. 44.

S 920. Dynasty V.

See QUIBELL, *Saqqara (1907-1908)*, p. 26.

Block with vase-makers, in Cairo Mus. JE 39866. Id. in MASPERO, *Le Musée Égyptien*, iii, pl. xxii, pp. 25-7; WRESZ., *Atlas*, iii. Beibild 33A; left part, WOLDERING, *Götter*, fig. on p. 233 [Kat. 57]; GOYON (G.) in *Jaarbericht Ex Oriente Lux*, No. 21 (1970), pl. xxiii [A], fig. 13, p. 159; right part, BONNET, *Ein frühgeschichtliches Gräberfeld bei Abusir*, Abb. 7, p. 11; man drilling on left, ENGELBACH, *Introduction*, fig. 22; CLARKE and ENGELBACH, *Ancient Egyptian Masonry*, fig. 246.

UNNUMBERED EARLY DYNASTIC AND OLD KINGDOM
TOMBS

(a) POSITION KNOWN

Mastaba X. Probably Late Dyn. I.

Between S 3506 and S 3507.

EMERY, *Great Tombs*, i, pp. 107-15; plan and section, pl. 43, figs. 7, 61; view, pl. 44.

Two inscribed labels, wood. Id. ib. pl. 45, figs. 65-6, p. 114 [73-4].

Jar-sealings of Den and Neska . Id. ib. fig. 61A, p. 109.

Stone vessels, inscribed, fragments. Texts, id. ib. fig. 62, pp. 111-12 [59-68].

KAEMḤEST , Overseer (*mdh*) of sculptors in the Two Houses, *mḥnk* of the King, etc. Dyn. IV-V.

North-west of No. 42 [C 7].

MURRAY, *Saqqara Mastabas*, i, p. 5; plan and elevations, pl. xxxiii.

Lower part of left jamb of doorway with titles. Id. ib. pl. iii [1]; see SETHE in ib. ii, p. 12 [14].

PTAḤSHEPSES [I] , Greatest of the Directors of craftsmen, Prophet of Ptah and Sokari, etc. Dyn. VI.

South of Nos. 37-8 [E 1, 2 and H 3].

MURRAY, *Saqqara Mastabas*, i, pp. 24-6, with plan, pl. xxxiv [bottom]. Titles, SETHE in ib. ii, p. 21 [23].

Chapel. Painted decoration.

Doorway. Drum with name and title; MURRAY, op. cit. i, pl. xxvii [top].

East wall. Registers, much damaged, I, butchers, II-III, offering-bringers; id. ib. pl. xxvii [bottom]; offering-bringer in II, id. *Eg. Sculpture*, pl. xv [1].

West wall. Palace-façade false-door, and offering-table; id. *Saqqara Mastabas*, i, pls. xxvi, xxvii [near top].

North wall. Deceased at table, much damaged; id. ib. pl. xxvii [middle].

NAME UNKNOWN. Early Dyn. V.

Near No. 39 [C 16].

Statues.

Scribe¹ writing, 'Cairo Scribe', in Cairo Mus. CG 36. BORCHARDT, *Statuen*, i, Bl. 9, pp. 34-5; BRUGSCH in *Egypt Exploration Fund. Archaeological Report 1892-3*, pl. facing p. 25;

¹ Selected references.

MASPERO, *Hist. anc.* i, fig. on p. 409; id. in *Mon. Piot*, i (1894), pl. i, pp. 1–6; id. *Essais*, fig. 11, pp. 59–65; id. *Eg. Art.*, pl. facing p. 66, cf. pp. 66–70; id. in *Gazette des Beaux Arts*, 3rd Pér. ix (1893), fig. on p. 269, cf. pp. 265–70; id. *Guide*, fig. 18, p. 66 [141]; *Descr. somm.* 4th pl. after p. 26 [No. 141]; CAPART, *L'Art ég.* (1909), pl. 20; id. *L'Art ég.* ii, p. 243; id. *Memphis*, fig. 269; id. in *J.E.A.* vii (1921), pl. xxxi [3], p. 190; WEIGALL, *Anc. Eg. . . . Art.*, 44; HORNEMANN, *Types*, ii, pl. 412; WOLDERING, *Götter*, Taf. ix on p. 73; RIESTERER, *Kunstschätze . . . Kairo*, pl. 1; WOLF, *Kunst*, Abb. 129; BOREUX, *L'Art ég.* pl. xxiv; PIJOÁN, *Summa Artis*, iii (1945), fig. 162; *Encycl. phot. Caire*, pls. 26–8; LANGE, *Pyramiden, Sphinx, Pharaonen*, pl. 75 after p. 184; id. and HIRMER, *Aegypten. Architektur* (1955 and 1957), pls. 58–9; (1967), pls. vi, 62; DE RACHEWILTZ, *L'Arte*, Tav. 39; DONADONI, *Arte Egizia*, fig. 35; id. *Egyptian Museum Cairo*, pl. on p. 46; SPIEGEL, *Hochkultur*, Taf. 44; VANDIER, *Eg. Sculpture*, pl. 31; LEBOVITCH, *Anc. Eg.* fig. 53; COTTRELL, *Egypt*, fig. 57; MONTET, *Lives of the Pharaohs*, fig. on p. 40; MICHALOWSKI, *Art*, figs. 9, 212; *Great Museums*, pl. 21; ANGIOLETTI and BIGONGIARI, *Testimone*, Tav. 11; VANDERSLEYEN, *Das Alte Ägypten*, Abb. xi. Upper part, FORMAN (W. and B.) and VILÍMKOVÁ, *Eg. Art.* pl. 21.

Man seated, in Cairo Mus. CG 35. BORCHARDT, *Statuen*, i, Bl. 9, pp. 33–4; WEIGALL, *Anc. Eg. . . . Art.*, 43 [lower]; CAPART, *L'Art ég.* ii, pl. 242; id. in *J.E.A.* vii (1921), pl. xxxi [4], p. 190; HORNEMANN, *Types*, iii, pl. 692; Essen. *5000 Jahre*, No. 28 with Abb.; Amsterdam. *5000 jaar*, fig. 8 [24]; Vienna. *5000 Jahre*, No. 25 with Abb.; DONADONI, *Egyptian Museum Cairo*, pl. on p. 44; PERC, *Spomeniki starega Egipta* (1974), No. 9 with fig. Upper part, LEBOVITCH, *Anc. Eg.* pl. x; PETRIE Giza photo. 535. See MASPERO, *Guide*, p. 66 [142].

(b) POSITION UNKNOWN

AKHTI'CA , Prophet of Nebka, Overseer of all works of the King, etc.
End of Dyn. III or early Dyn. IV.

See WEILL, *La II^e et la III^e dynasties*, pp. 262–73.

Doorway. Thicknesses, deceased with titles above, in Louvre, B 1 [N.121] (left, upper part only), B 2 [N.122] (right); id. ib. pl. vi [upper]; ARCHIVES phot. E.1209, and 48; see DE ROUGÉ, *Notice des monuments* (1883), pp. 54–5; BOREUX, *Guide*, i, pp. 238–9, 245; VANDIER, *Guide* (1948 and 1952), p. 6; (1973), p. 9. B 1, DEVÉRIA squeezes, 6166, ii. 114; 6169, ii. 64; text, PIERRET, *Rec. inscr.* ii, p. 74 [lower]. B 2, SMITH, *Hist. Eg. Sculp.* pl. 35, p. 151; *Encycl. phot. Louvre*, i, pls. 8, 9; RICHER, *Le Nu*, fig. 72 (as B 1); WILKINSON MSS. xxiv. 14 [left]; deceased, PIJOÁN, *Summa Artis*, iii (1945), fig. 107; head, VANDIER, *Eg. Sculpture*, pl. 11.

False-door. Blocks with titles, in Berlin Mus. 1141 (East), 1142 (both re-used in village of Abûšîr), 15302–3, and Leipzig, Äg. Mus. Inv. 2897. Reconstruction, SMITH (W. S.) in *A. J. A.* xlvi (1942), fig. 9, pp. 518–20; see id. *Hist. Eg. Sculp.* p. 151 note 2. Berlin 1141–2, L. D. ii. 39 [a, b], *Text*, i, p. 138; WEILL, op. cit. pl. vii [upper]; texts, *Aeg. Inschr.* i, p. 30; see *Ausf. Verz.* p. 59. Berlin Mus. 15302–3, WEILL, op. cit. pl. vii [lower]; texts, *Aeg. Inschr.* i, pp. 31 (as Nos. 13502–3 in error), 267. Leipzig, Äg. Mus. Inv. 2897, SMITH (W. S.) in *A. J. A.* xlvi (1942), fig. 7, pp. 518, 520.

Block with text mentioning wife, re-used in village of Abûšîr; L. D. *Text*, i, p. 139 [top right].

Statue of deceased seated, lower part, granite, in Berlin (East) Mus. 14277. WEILL, op. cit. pl. vi [lower], fig. on p. 272; *Sculptures et textes*, fig. on p. 68; text, *Aeg. Inschr.* i, p. 68 (reversed). See *Ausf. Verz.* p. 66.

KACAPER $\text{𓆎} \text{𓆏} \text{𓆑}$, Judge and Boundary official, Scribe of the King's expedition in Wenet, Serer, Tapa and Ida, etc. Early Dyn. V.

Plan XLIX.

Wife, Thenteti $\text{𓆎} \text{𓆏} \text{𓆑}$, Royal acquaintance.

FISCHER in *J.N.E.S.* xviii (1959), pp. 233-72, with plan, fig. 3, and titles, fig. 22.

Chapel. Fragment with titles, id. ib. pl. ix [A], p. 235 [E].

(1) Deceased seated watching men netting fish, with another man seated beyond, in New York, M.M.A. 58.161.

Id. ib. pl. vii, figs. 5-7, pp. 235-6 [B], 241-4.

(2) Upper part of false-door (panel in Detroit, Institute of Arts, 57.58).

Id. ib. pls. iv, v, fig. 1, pp. 234-5 [A], 237-41, 255-7. Detroit panel, PECK in *The Connoisseur*, clxxv (1970), fig. on p. 267 [upper left]; see *Bulletin of The Detroit Institute of Arts*, 37 (1958), p. 33.

(3) Upper part of deceased and wife (in Kansas City, William Rockhill Nelson Gallery of Art, 46-33), and titles.

FISCHER, op. cit. pl. viii, fig. 21, pp. 235 [D], 254. Name of country Serer, id. in *J.A.R.C.E.* ii (1963), fig. 1, p. 50.

(4) Deceased embraced by wife, with two remaining registers behind them, dwarf before flutist, and monkey before harpist.

Id. in *J.N.E.S.* xviii (1959), pl. vi, figs. 2, 8, pp. 235 [C], 237, 244-54.

MERY $\text{𓆎} \text{𓆏} \text{𓆑}$, Overseer of scribes of the royal documents, Overseer of the Treasury, Prophet of Termuthis, etc. Middle Dyn. IV.

Plan L.

Wife, Ni'ankhwazet $\text{𓆎} \text{𓆏} \text{𓆑}$, Prophetess of Hathor, etc.

Blocks.¹ Remains of names and titles, in Louvre, E.14223; WEILL in *Sphinx*, xv (1911-12), fig. on p. 6, cf. pp. 6-9; see *Annuaire des Musées Nationaux* (1932), p. 24; SMITH (W. S.) in *A.J.A.* xlvi (1942), p. 514 [middle]. Head and titles, in Strasbourg, Univ. Inst. d'Égyptologie, 342; *Antiquités égyptiennes* (Strasbourg, Exposition . . . 12 juillet-15 octobre 1973), fig. 22.

False-door.¹ (1) Upper part of deceased, with name and titles, in Louvre, B 49b. (2) Wife with son Mery, and ka-servant and scribe below, with right edge of (1), in Louvre, B 49c. (3) Upper part of deceased, in Pittsburgh, Museum of Art, Carnegie Institute, 73.11. (4) Deceased, in Chicago, Field Mus. Nat. Hist. A.31309. (5) Wife smelling lotus, and son, with right edge of (4), in Cairo Mus. CG 1388. (7) Wife smelling lotus, and daughter, with left edge of (6) with back of deceased, in New York, M.M.A. X.179. (8) Panel, deceased at table, with palace-façade on both sides, in Louvre, B 49a, and lintel, in New York, M.M.A. 67.50.



Reconstruction, SMITH (W. S.), op. cit. fig. 1, pp. 510-15, and omitting lintel and (3), figs. 2-4; see id. *Hist. Eg. Sculp.* pp. 172 with note 3, 173. Blocks in Louvre, ARCHIVES phot. E.656; see DE ROUGÉ, *Notice des monuments* (1883), p. 67; BOREUX, *Guide*, i, pp. 235-6; VANDIER, *Guide* (1948 and 1952), p. 9; (1973), p. 14; WEILL, *La II^e et la III^e dynasties*, pp. 300-4. (1) VANDIER, *Eg. Sculpture*, pl. 10; *Encycl. phot. Louvre*, i, pl. 7; WILKINSON MSS. xxiv. 13 [right]; deceased, BOREUX, *Sculpture*, pl. vi; text, PIERRET, *Rec. Inscr.* ii, p. 74 [upper]; DEVÉRIA squeezes, 6169, ii. 63; title of Prophet of Termuthis, see LEIBOVITCH in *J.N.E.S.* xii (1953), pp. 81 [28], cf. 105 with note 30. (2) Ka-servant and scribe,



¹ See Addenda.

CLÈRE in *Mélanges Maspero*, i [2], p. 759 with plate. (3) OWSLEY in *Carnegie Magazine*, xlvii [6] (June 1973), figs. 1, cf. 2, p. 228; *The Art Journal*, xxxii [1] (Fall 1972), fig. on p. 1; see *The Art Quarterly*, xxxvi (1973), p. 425. (5) BORCHARDT, *Denkmäler*, i, Bl. 11, p. 49; upper part of wife, BÉNÉDITE, *L'Art égyptien dans ses lignes générales*, pl. xiv, p. 24; MASPERO, *Égypte*, fig. 99 (as Kagemni); PIRENNE, *Hist. civ.* i, pl. 63 between pp. 188–9; ZALOSKER in *Alte und moderne Kunst*, 15 [108] (1970), fig. 1, p. 2. (7) HAYES, *Scepter*, i, fig. 48, pp. 88–9. (8) Panel, STAEHELIN, *Tracht*, Taf. iv [6]; KAPLONY, *Kleine Beiträge*, Taf. vii [1099], p. 105; WILKINSON MSS. xxiv. 13 [left upper]; DEVÉRIA squeezes, 6169, ii. 65; texts, WEILL, op. cit. fig. on p. 300; BRUGSCH, *Thes.* 1411 [lower], cf. 1230 [bottom]; PIERRET, op. cit. ii, p. 56 [B.49].

NŪFER , Craftsman. Dyn. IV or later.

Wife (probably), My , *mitri*.

Parts of two false-doors with names of deceased, wife, and Iywat  , Butcher of the slaughterhouse. In Brussels, Mus. Roy. E.5268, 5271 (both lintels), 5270 (drum); FISCHER in *Orientalia*, n.s. 29 (1960), fig. 3, pp. 171–2; id. in *Metropolitan Museum Journal*, 8 (1973), figs. 18, 19 [left], p. 19 [21]; texts, SPELEERS, *Rec. inscr.* p. 4 [32, 34–5]; E.5268, 5270, WEILL, *La II^e et la III^e dynasties*, pp. 316–17 [1] with fig.; E.5271, id. in *Sphinx*, xv (1911–12), fig. on p. 4. In Chicago, Field Mus. Nat. Hist. A.31297 (drum); FISCHER in *Metropolitan Museum Journal*, 8 (1973), fig. 19 [right], p. 19 [21] with note 30.

PEḤERNŪFER  , Overseer of all works of the King, Chief of the estate of Meresankh, Prophet of Thoth, Sopt, Ḥeḫet, etc. Temp. Snefru or Khufu.

Plan L.

Excavated by Nestor l'Hôte before 1840.

MASPERO in *Études Égyptiennes*, ii, pp. 246–71 (from NESTOR L'HÔTE). Titles and estates, JUNKER in *Ä.Z.* 75 (1939), pp. 63–73 (from NESTOR L'HÔTE). Some titles, L. *D. Text*, i, p. 188 [3, 2nd block].



Chapel. Plan, MASPERO, op. cit. p. 246; NESTOR L'HÔTE MSS. 20396, 338 [top].

(1) [1st ed. 1–3] Doorway. (a)–(b) Lintel and drum with titles and name, id. ib. 341 (sketch); titles on drum, MASPERO, op. cit. p. 247 [top]. (c) and (d) Thicknesses; (c) titles, NESTOR L'HÔTE MSS. 20396, 338 verso [top]; (d) deceased with titles, id. ib. 338; titles beneath arm, MASPERO, op. cit. p. 267 [top].

(2) [1st ed. 7] Deceased in panther-skin. NESTOR L'HÔTE MSS. 20396, 338 verso [left].

(3) and (4) [1st ed. 4, 6] Four registers of estates. (3) Names, id. ib. 339; MASPERO, op. cit. p. 248 [top]; JACQUET-GORDON, *Domaines*, pp. 328–30 [4S4], Nos. 10–16, cf. figs. 115, 116 [a] and note 4 on p. 328. (4) Heads and names, NESTOR L'HÔTE MSS. 20396, 338 verso [right]; names, MASPERO, op. cit. p. 247 [bottom]; JACQUET-GORDON, op. cit. pp. 328–9 [4S4], Nos. 1–8, cf. figs. 115, 116 [b] and note 4 on p. 328; of two, L. *D. Text*, i, p. 188 [3, 1st block].

(5) [1st ed. 5, 8–11] False-door. (a)–(e) Deceased with titles. (a) NESTOR L'HÔTE MSS. 20396, 339 verso [left], cf. id. 20406, 'Tombeau de Peḥernofre I', squeezes; titles, MASPERO, op. cit. p. 248 [lower]. (b)–(e) NESTOR L'HÔTE MSS. 20396, 340 [left], 340 [right], 339 verso [right], 340 verso.

TETI  and NEFERHERES , Scribes of the archives. Late Dyn. III or early Dyn. IV.

Stela with both deceased at table. Texts, KAPLONY, *Inschriften*, iii, Taf. 138 [837] (from sketch by W. S. Smith); ii, p. 1194; i, pp. 233 [36], 546, 660 [36]. See SMITH, *Hist. Eg. Sculp.* pp. 143, 150 note 1, 303.



Lintel of Hesi , Royal acquaintance, and son Teti. WEILL in *Sphinx*, xv (1911-12), fig. on p. 5.

Drums, possibly from here. Hes, Royal acquaintance, Neferhor , Royal scribe, and Teti, Royal acquaintance, in London, Univ. Coll. 14285-7; see PETRIE, *Handbook . . . Univ. Coll.* June 7-July 3, 1915, No. 555. Teti, Royal acquaintance, in Louvre, C 157 [N.307]; PERROT and CHIPIEZ, *Hist. de l'Art*, i, fig. 111; WILKINSON MSS. xxiv. 11 [middle right]; see DE ROUGÉ, *Notice des monuments* (1883), p. 134.

LATE PERIOD, PTOLEMAIC AND ROMAN TOMBS

Mostly along the Avenue of Sphinxes

LS 7.

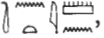
Sarcophagus-lid of Thaihepimu , and sarcophagus of Gemḥap , Prophet of Bubastis Mistress of Heliopolis, Commander of the army, son of Thaienhorimu  and Tentamūn , Late Period. Names and titles, L. D. Text, i, p. 144. Sarcophagus of Gemḥap, LIEDER squeezes, 11.1-6.

UZAḤOR . Dyn. XXVII.

Exact position unknown.



Mother, Ēsiemkhebi .

BARSANTI in *Ann. Serv.* iii (1902), pp. 209-12.

Sarcophagus. Remains of text, id. ib. p. 210.

Four canopic-jars, alabaster, in Cairo Mus. JE 35360. See id. ib. p. 211.

Silver gilt bands (inscribed) and mask, from inner coffin, in Cairo Mus. CG 53770-3, 53778. Id. ib. pl. i [5, 6], p. 210; see VERNIER, *Bijoux et orfèvreries (Cat. Caire)*, pp. 498, 499.

UNNŪFER , Prophet of Nektanebos I the hawk, Prophet of the statues of Thaihepimu  (father of Nektanebos II), etc. Temp. Nektanebos II.

Map XLVI, E-2.

Father, Painmu .

MARIETTE, *Sérapeum, Texte*, pp. 11-13. Plan, DEVÉRIA squeezes, 5387G, cover. Views, QUIBELL, *Saqqara (1912-1914)*, pl. xxxvi, p. 14.

Exterior. Texts, DEVÉRIA squeezes, 5387C, G.

Pillared Hall.

Walls. Texts, id. ib. F. Relief-fragments, QUIBELL, op. cit. pl. xxxvii [1, 2], p. 14.

Pillars. Texts, DEVÉRIA squeezes, 5387B.

Chapels.

Doorways; texts, id. ib. A. Walls; texts, id. ib. D.

Burial chamber. View of shaft, QUIBELL, *op. cit.* pl. xxxvii [4].

Anthropoid sarcophagus, granite, in New York, M.M.A. 11.154.1. CAIRO, CENTRE OF DOCUMENTATION photos. S.A., 1829, 1832-4, 1838-40. Texts (omitting lid), DEVÉRIA squeezes, 5387E. Some titles, DE MEULENAERE in *Chron. d'Ég.* xxxv (1960), p. 93 [2]; id. in *Ā.Z.* 90 (1963), p. 91. See QUIBELL in *Egypt Exploration Fund. Archaeological Report 1910-1911*, p. 24.

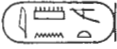
Cylindrical vase of Merytamūn  (daughter of Ramesses II), alabaster, found by Mariette at bottom of shaft in 1852, in Louvre, N.495. VANDIER D'ABBADIE, *Catalogue des objets de toilette égyptiens*, No. 555 with fig. (text, called N.465); WILKINSON MSS. xxiv. 25 [middle bottom]. See PIERRET, *Cat.* No. 377; BOREUX, *Guide*, ii, p. 570; VANDIER, *Guide* (1973), p. 80.

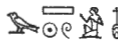

WERSHNŪFER , Prophet of Mut Mistress of Asher, etc. Dyn. XXX or Ptolemaic.





Map XLVI, E-4.

Sarcophagus, with bending Nut and representation of world on lid, diorite, in New York, M.M.A. 14.7.1. C. L. R[ANSOM] in *M.M.A. Bull.* ix (1914), pp. 112-20 with figs. 1-5; Nut and representation of world, WORRINGER, *Ägyptische Kunst*, Abb. 11; RANKE, *The Art of Ancient Egypt*, and BREASTED, *Geschichte Aegyptens* (1936), 243; SANDER-HANSEN, *Aegyptiske Forestillinger om Verdens Skabelse*, pl. ii; PIJOÁN, *Summa Artis*, iii (1945), fig. 623; *Egypt Trav. Mag.* No. 10 (May 1955), fig. on p. 44 [lower]; POSENER, SAUNERON and YOYOTTE, *Dict. civ.* fig. on p. 192; DE RACHEWILTZ, *Vita nell'antico Egitto*, Tav. x [left]; PIRENNE, *Hist. civ.* iii, pl. 105 facing p. 384; SCHOTT in *Bull. Soc. fr. d'Ég.* Nos. 53-4 (Feb. 1969), pl. viii, p. 40; KÁKOSY in *Ā.Z.* 97 (1971), Abb. 4, p. 101 with note 34; see GARDINER in *J.E.A.* 30 (1944), p. 38, cf. pl. v [1]; CLÈRE in *Mitt. Kairo*, 16 (1958), p. 30 with fig. 1 (from RANSOM).

TOMB WITH SARCOPHAGI OF DYN. XXX.



Exact position unknown.

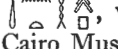

Thaiḥarpata , son of 'Ankh-ḥap  and Tefnut , year 15 of Nektanebos II, granite, in Cairo Mus. CG 29306. MASPERO, *Sarcophages*, i, pls. xix-xxi, pp. 218-315; CAIRO, CENTRE OF DOCUMENTATION photos. S.A., 1830-1, 1836; *in situ*, QUIBELL, *Saqqara (1912-1914)*, pl. xxxiv, p. 13; part of text with date [MASPERO, p. 256], SPIEGELBERG in *Ā.Z.* 64 (1929), p. 76; BRUGSCH, *Recueil*, pl. vi [1] (as Ḥarpto and Vienna Mus.); texts of Book of Caverns, 1st division, PIANKOFF in *B.I.F.A.O.* xli (1942), pls. iii-ix, pp. 2, 6-11 [S]; 2nd division, id. ib. xlii (1944), pls. xi-xxvi [left], pp. 3-14 [S]; name and titles, BRUGSCH, *Geographische Inschriften altägyptischer Denkmäler*, iii, Taf. xiv [48-53], pp. 34-6; see GAUTHIER in *B.I.F.A.O.* xii (1916), pp. 52-6; MASPERO, *Guide*, p. 178 [629]. Funerary equipment, in Cairo Mus. Temp. No. 11.12.25.18, see id. ib. p. 351 [3405].

Pawenhētef  Zehō , dwarf, son of Pedekhons  and Tawonshet  Tentḥap , with deceased on lid and text mentioning Thaiḥarpata (see above), granite, in Cairo Mus. CG 29307. MASPERO, *Sarcophages*, i, pls. xxii-xxvi, p. 220

[top]; id. and GAUTHIER, *ib.* ii, pls. i-vi, pp. 1-17; CAIRO, CENTRE OF DOCUMENTATION photos. S.A., 1764, 1766, 1837; lid, QUIBELL, *Saqqara (1912-1914)*, pls. xxxv, cf. xxxiv, p. 13; *Encycl. phot. Caire*, pl. 180; RIAD, *La Médecine au temps des Pharaons*, fig. 14; MONTET, *Lives of the Pharaohs*, pl. on p. 265; MICHALOWSKI, *Art*, fig. 742; HUDSON, *A Social History of Museums*, fig. on p. 144; interior with Western goddess, ROEDER, *Der Ausklang der ägyptischen Religion* [etc.], Taf. 16, p. 236; parts of text, SPIEGELBERG in *Ä.Z.* 64 (1929), pp. 79, 82; see MASPERO, *Guide*, p. 267 [1294].

Pefteu(au)khons , Leader of the House, Secretary of the Per-duat, etc., granite, in Chicago, Field Mus. Nat. Hist. A.105175. MARTIN, *Mummies*, pl. 6 and fig. on p. 5; name, QUIBELL in *Egypt Exploration Fund. Archaeological Report 1910-1911*, p. 24.

ʿAnkh-ḥap , son of Es-isut  and Tiamūn , granite, in Cairo Mus. CG 29308. MASPERO and GAUTHIER, *Sarcophages*, ii, pls. vii, viii, pp. 17-20.



Ēsiardais , daughter of Tadeusiri  (mother), anthropoid, limestone, in New York, M.M.A. 11.154.6. QUIBELL, *Saqqara (1912-1914)*, pl. xxxvii [3], p. 14; BUHL, *Sarcophagi*, fig. 75, pp. 126-7 [H, 2]; CAIRO, CENTRE OF DOCUMENTATION photo. S.A., 1772.

Zehō, Scribe of the Pharaoh, Prophet of Ḥathōr, son of Tekʿan(?)  (mother), anthropoid, possibly from here. CAIRO, CENTRE OF DOCUMENTATION photos. S.A., 1773-4.

PTOLEMAIC OR ROMAN TOMB. Between tombs Nos. I and II of Basta.



Position, see BASTA in *Ann. Serv.* lix (1966), p. 15 with pl. i.

Anthropoid sarcophagus with cursive text in ink. Id. *ib.* pls. vi, vii, p. 17.

Wooden Osiride statuette of Ḥapī , son of Pakhar . Id. *ib.* pls. viii, ix, p. 18.

PTOLEMAIC OR ROMAN TOMB. No. VI of Basta.

Position, see preceding tomb.



Wooden coffin of Pernūfer , son of Tadeusiri  (mother). BASTA in *Ann. Serv.* lix (1966), pl. xi, p. 20.

FINDS FROM NORTH OF THE STEP PYRAMID

Statues. In Cairo Museum.

Fragment of seated statue of Nikaʿankh , dedicated by son Ptaḥshepses, Dyn. VI, CG 67. Text, BORCHARDT, *Statuen*, i, p. 58 with note 1.

Seated statue, granite, Dyn. V, probably from near tomb No. 49 [C 10], CG 85. Id. *ib.* Bl. 19, p. 68; DRIOTON and SVED, *Art ég.* fig. 23; HORNE-MANN, *Types*, iii, pl. 691.

Statue-base with remains of feet, of Iymery , Director of smelters of gold, etc., and Mertiotēs  (woman), late Old Kingdom, found above tomb S 3050, JE 91917. MARTIN, *Ḥetepka*, No. 84. Name, id. in *J.E.A.* 60 (1974), p. 23.

Fragment of male statue, Dyn. V, CG 372. See BORCHARDT, *op. cit.* p. 195.

Niche-stelae.

Iau  (formerly as Nebiau), Dyn. III or early Dyn. IV, in Cairo Mus. CG 57180. KAPLONY, *Kleine Beiträge*, Taf. vi [839], p. 105 [Sp. 39]; id. *Inschriften*, iii, Taf. 140 [839];



ii, p. 1194; i, pp. 233 [39], 400; see REISNER, *Tomb Development*, pp. 296 [7], 398 [top]; SMITH, *Hist. Eg. Sculp.* pp. 142, 143.



Imti , Director of leather-workers, etc., Dyn. II. SMITH, *Art . . . Anc. Eg.* pl. 13, p. 28; see KAPLONY, *Inschriften*, i, pp. 233 [34], 417.



Khnemtneit  (woman), Dyn. III. Id. ib. iii, Taf. 139 [836] (sketch by W. S. Smith); ii, p. 1194; i, pp. 232 [33], 606; see SMITH, *Hist. Eg. Sculp.* p. 143.

Wepka , Dyn. III. QUIBELL, *Saqqara (1912-1914)*, pl. xxviii [1], p. 10; see SMITH, *Hist. Eg. Sculp.* p. 143.

False-doors and stelae.



False-door of Hsesi , Overseer of the Two Treasuries and the Two Granaries, etc., with sons Sheshi  and Ty , Dyn. VI, in Cairo Mus. CG 1413. BORCHARDT, *Denkmäler*, i, Bl. 19, pp. 78-80; MASPERO in GRÉBAUT, *Le Musée Égyptien*, i, pl. xxii, pp. 19-21; id. *Guide* (1914), fig. 5 on p. 19; (1915), fig. 8 on p. 22, cf. pp. 78-9 [175]; id. and ROEDER, *Führer*, Taf. 13 [b], p. 26 [107]; VANDIER, *Manuel*, ii, fig. 278 [upper right] on p. 407.

False-door, Inba , *ka*-servant, and wife Pepi , *mītrt*, late Old Kingdom, found re-used between tombs S 3513 and 3514, in Birmingham, City Mus. 596.69. MARTIN, *Hetepka*, No. 30.

Stela, Khathap¹  (Phoenician), Head of police in Memphis, son of Paneit  and Tanennüter , before Nut as sycamore-tree libating to *ba*, with Western goddess behind, and hieroglyphic and demotic text with dates of birth and death as 273 and 203 B.C., found between tombs LS 6 and 7, in Berlin Mus. 2118. SCHÄFER in *Ä.Z.* xl (1902), Taf. i, pp. 31-5; id. *Äg. Kunst*, fig. on p. 22 [4]; BRUNNER, *Hieroglyphische Chrestomathie*, Taf. 26. Scene, SCHÄFER and ANDRAE, *Kunst* (1925), 439 [upper]; (1930 and 1942), 455 [upper]; VAN DER LEEUW, *De Godsdienst van het oude Aegypte*, pl. 39 facing p. 77; HAAS, *Bilderatlas zur Religionsgeschichte*, fig. 136. Text and deceased, STERN in *Ä.Z.* xxii (1884), pp. 101-9; text, SETHE, *Urk.* ii. 162-6 [35]. See *Ausf. Verz.* pp. 335-6; *L. D. Text*, i, p. 222 [bottom]; MUNRO, *Die spätägyptischen Totenstelen*, p. 336.

Blocks.

Butchers, Dyn. V, in Cairo Mus. CG 1530. BORCHARDT, *Denkmäler*, i, Bl. 46, p. 229.

Mereruka  Metetu , Metal-worker of the Great House, etc., end of Dyn. V or Dyn. VI. (a) Cairo Mus. CG 1540; id. ib. Bl. 52, pp. 243-4; text, ČERNÝ Notebook, 118, p. 86. (b) Brit. Mus. 1185; *Hiero. Texts*, i, pl. 28 [38]; i², pl. xxi [4], pp. 21-2; see *Guide (Sculpture)*, p. 12 [38]. (c) Rochester (New York), University Memorial Art Gallery; *Gazette des Beaux-Arts*, lxxxiii (1974), Supp. Feb. 1974, fig. 315 on p. 97. See SCHOTT (E.) in *Göttinger Miscellen*, No. 4 (1973), p. 31.

Lintel of Yunmin , Overseer of judgement, Director of scribes, Dyn. V-VI. MARIETTE, *Mastabas*, p. 445 [top].

Weni , Overseer of *ka*-servants, etc., at table, Dyn. VI, in Cairo Mus. CG 1599. BORCHARDT, *Denkmäler*, ii, Bl. 80, p. 76.

Iymery (probably same man as on statue-base, see *supra*), lintel-fragment. MARTIN, *Hetepka*, No. 103.

Canoe, and men bringing fowl, unfinished, Old Kingdom, in Cairo Mus. CG 1721 See BORCHARDT, *op. cit.* ii, p. 155.

¹ Head of marble sarcophagus, in Berlin (East) Mus. 2123, FURTWÄGLER in *Archäologische Studien . . . Heinrich Brunn* (1893), Taf. ii, figs. on p. 69; see *Ausf. Verz.* p. 342.

Chariot-scenes, with name of 'his brother' Thay , Royal scribe of memoranda, Dyn. XIX. COONEY, *Amarna Reliefs from Hermopolis in American Collections*, fig. 30a (by James), pp. 52, 54.

Sarcophagi. Ptolemaic unless otherwise stated.

'Ankh-hap , Prophet of the Ram of Mendes, son of Tefnakht , granite, found about 600 metres north-east of Serapeum, in Cairo Mus. CG 29303. MASPERO, *Sarcophages*, i, pls. ix-xiii, pp. 86-114; MAHAFFY, *A History of Egypt* [etc.], iv (1899), fig. 16 on p. 65; SCHMIDT, *Levende og Døde*, fig. 1217; names, LIEBLEIN, *Dict.* No. 1195; see MASPERO, *Guide*, p. 266 [1292].

Baiyti , (mother of Zehō, see below), daughter of Tentkem , (mother), anthropoid, basalt, in Cairo Mus. Temp. Nos. 20.1.21.1, 2. BUHL, *Sarcophagi*, fig. 77, pp. 135-6 [I, 2]; texts, PIEHL, *Inscr. hiéro.* I Sér. pls. lxvi-lxviii [H], pp. 61-3; names, LIEBLEIN, *Dict.* No. 1073; see MASPERO, *Guide*, p. 270 [1302].

Esshu-tefnut , Prophet of Osiris of Busiris in Hurent , Royal scribe of accounts of all things of Upper and Lower Egypt, etc., son of Thai-inhertimu and Tehent , granite, early Ptolemaic, in Vienna Mus. Inv. 1 (as Inv. 11 in 1st ed.). ARNETH, *Über den in der ersten Hälfte Jänners des Jahres zu Wien angekommenen ägyptischen Sarkophag in Sitzungsb. Wien*, x (1853), with nine plates; KOMORZYNSKI, *Das Erbe des alien Ägypten*, Abb. 77-81; SEYFFARTH MSS. xiv. 11465-70; Aker and four Na'ry (fish-genii), CAPART in *Chron. d'Ég.* xiv (1939), fig. 4, p. 215; GAMER-WALLERT, *Fische und Fischkulte im Alten Ägypten*, Taf. xii [2], pp. 116-17; kneeling goddess from lid, KOMORZYNSKI, *Altägypten*, Abb. 43; texts, BRUGSCH, *Recueil*, pl. vi [2, 3]; VON BERGMANN in *Rec. Trav.* vi (1885), pp. 133-63; WILBOUR MSS. 3 C.361-7; names and titles, LIEBLEIN, *Dict.* No. 1049; see *Uebersicht* (1895), p. 34 [XIX]; (1923), p. 10 [XIX]; *Führer durch die Sammlungen des Kunsthistorischen Museums* (1967), p. 8. Inscribed wooden plank (name as , found in sarcophagus, in Vienna Mus. Inv. 240; text, VON BERGMANN, *op. cit.* p. 163; WRESZINSKI, *Aegyptische Inschriften aus dem K.K. Hofmuseum in Wien*, pp. 176-9 [v. 1]; see *Uebersicht* (1895), p. 41 [11]; (1923), p. 16 [11].

Harkhebi , son of Takher (or Kheter) (mother), probably Ptolemaic, found near Avenue of Sphinxes. Texts, MARIETTE, *Mastabas*, p. 458 [H 16].

Two, Zehō , General-in-chief of His Majesty, son of 'Aḥmosi , same title, and Baiyti (see above), granite, in Cairo Mus. CG 29304-5. Names and titles, LIEBLEIN, *Dict.* No. 1191; DE ROUGÉ, *Inscr. hiéro.* pl. lvi [upper middle]; see MASPERO, *Guide*, pp. 266-7 [1291, 1293]. CG 29304, see *id.* *Sarcophages*, i, pp. 114-61; parts of texts, PIEHL, *Inscr. hiéro.* I Sér. pls. lxviii-lxx [I], pp. 63-4. CG 29305, MASPERO, *Sarcophages*, i, pls. xiv-xviii, pp. 161-218 (with texts); SCHMIDT, *Levende og Døde*, figs. 1219, 1221; GRIFFITH INST. photo. 347; Osiris and weighing-scene from 5th division of Book of Gates, PIANKOFF in *Ann. Serv.* lv (1958), pl. iv, p. 159.

Other finds.

Offering-table of Kai , Official (*sr*) of the Acacia-house, probably Dyn. VI, in Cairo Mus. CG 1373. Text, BORCHARDT, *Denkmäler*, i, p. 34.

Sealing, Dyn. I-II, in Toronto Mus. 969.137.7. See NEEDLER in *Rotunda. The Bulletin of the Royal Ontario Museum*, 2 [4] (1969), p. 26.

Faience cartouche-plaque from foundation deposit of Nektanebos II, found east of tomb No. 60 [D 22], in Cairo Mus. JE 59119.

B. AROUND TETI PYRAMID

Map LI

NORTH OF THE PYRAMID

Map LII

Plan, LORET in *Bull. Inst. Ég.* iii Sér. 10 (1899), facing p. 100, cf. pp. 86–100; FIRTH and GUNN, *Teti Pyr. Cem.* ii, pl. 51; JAMES and APTED, *The Mastaba of Khentika called Ikhekhi*, pl. ii. View, id. ib. pl. 1.



(a) LATE DYNASTY VI AND 1ST INT. PERIOD

INTI  , King's eldest daughter of his body (of Teti). Temp. Pepy I or later.

South-east of tomb of Khentka Ikhekhi (see below). Position not marked on map.

Niche. Lintel with offering-text, jambs with name and titles, thicknesses with name of Pyramid of Pepy I and two men before deceased, and false-door. GUNN MSS. xiv. 21–4; R.1.7, 16; R.6.2 (photos. and tracings); Notebook, 19, pp. 62–3; first four lines on lintel, and name and title from thickness, WILSON in *J.N.E.S.* xiii (1954), fig. 5 [VIII] (copied by Nims), p. 261 [f].

Lintel with offering-text. Text, GUNN MSS. xv. 33; Notebook, 10, No. 40.

KHENTKA  IKHEKHI , Real Chief Justice and Vizier (probably of Teti and Pepy I), Inspector of prophets of the Pyramids of Teti and Pepy I, etc. Temp. Pepy I.

Map LII. Plan LIII.

JAMES and APTED, *The Mastaba of Khentika called Ikhekhi* (hereafter JAMES). Texts, GUNN Notebook, 18, passim; 19, pp. 1–14, 18–20 [upper], 44–52, 56–60; ČERNÝ Notebook, 118, pp. 96 verso, 97–8; 119, pp. 69–96. Plans, JAMES, pls. iii, iv, and figs. in text. Views, id. ib. pl. i; GUNN MSS. xiv. 10 [1], 11 [1], 12 [1] (photos.).

Two blocks with deceased, probably from Enclosure Wall. JAMES, pl. xli [III, IV], pp. 19, 33, 67.

Façade.

Two blocks from frieze-text. Id. ib. pl. viii [V, VI], pp. 19, 33, 36.

(1)–(6) Name and titles, and deceased seated.

Id. ib. pls. v [left], vi [right], viii [except V, VI], pp. 19, 36 [1–4].

(7)–(10) Deceased seated at each, with addresses at (7)–(9) and conventional biographical text at (10).

Id. ib. pls. v [except left], vi [except right], pp. 19–20, 36–41 [7–10]. Texts, including parts of (1)–(6), GUNN MSS. iv. A.19, and xiv. 3–6, 7 [1, 2], 8, 9 (photos.). Corrections of text at (9) and (10), WILD in *Bibliotheca Orientalis*, xii (1955), fig. B on p. 15, cf. p. 16.



Room I.

(11) Doorway. (a)–(b) Lintel with double-scene, deceased seated and offering-texts, drum with name and titles, jambs with deceased; (c) and (d) deceased as fat man.

JAMES, pl. vii, pp. 20, 41–2 [11–17]. (a)–(b) GUNN MSS. xiv. 20 (photo.).

(12) Two registers, Ishetma^c  and another man offering ducks and censuring to statues of deceased.

JAMES, pl. x [left], pp. 20, 43 [22-6].

(13) Deceased painting seasons, with son Tetizedi  (also Pepyzedi ) elsewhere) and two men with scribe's equipment.

Id. ib. pl. x [right], pp. 20-1, 43 [18-21]; GUNN MSS. R.3.1.

(14) Remains of bringing animals. JAMES, pl. xi [upper], p. 21 [top].

(15) Registers, I, IV, V, baking and brewing, II, deceased and two scribes, and chiefs of estates rendering accounts, with two tied to whipping-post, III, scribes, and men filling granaries.

Id. ib. pl. ix, pp. 21-2, 43-6 [27-68]; WRESZ., *Atlas*, iii. 71.

(16) Registers, I (incomplete), people squatting, II, manicure and pedicure, III, boys' game with bound man with yoke round his neck.

JAMES, pl. xi [lower], pp. 21, 46 [69-77]; WRESZ., *Atlas*, iii. 23; GUNN MSS. R.3.2. III, WILD in *Bibliotheca Orientalis*, xii (1955), fig. A on p. 15, cf. p. 14.

Room II.

Remains of two registers of offering-bringers on thickness of earlier doorway in north-east corner, JAMES, pl. xii [A], p. 22.

Room III. View, GUNN MSS. xiv. 11 [2] (photo.).

False-door of son Pepyzedi or Zedi. JAMES, pl. xlii [XI], pp. 5, 33-4 [bottom], 69 [XI] with fig. 18; text, GUNN MSS. xv. 6.

(17) Deceased at table, with [offering-list], offerings, priests and offering-bringers.

JAMES, pl. xiv, pp. 22-3, 49 [83-94]. Text in bottom register, FIRTH and GUNN, *Teti Pyr. Cem.* i, p. 155 note 1 [f]. Block with offering-list, JAMES, pl. xliii [XV], pp. 34, 70-1 [XV].

(18) Originally similar to (17). Two men bringing haunches, from bottom register, id. ib. pl. xii [B], pp. 23, 49 [81-2]. Blocks with offering-list and upper part of deceased, id. ib. pl. xliii [XIII, XIV], pp. 34, 70-1 [XIII, XIV].

(19) Two false-doors, with offerings above. Id. ib. pl. xiii, pp. 22, 47-9 [78-80] with fig. 15. False-doors, GUNN MSS. xiv. 13 (photos.).

Room IV.

(20) Remains of man bringing animal. JAMES, pl. xv [top left], p. 24.

(21) Remains of deceased. Id. ib. pl. xv [top right], p. 24.

(22) Remains of marsh-scene with fish, crocodile and hippopotamus.

Id. ib. pl. xv [near top], p. 24. Fragments, id. ib. pl. xlii [XVI], p. 34.

Room VI.

(23) Remains of rowing-boats. Id. ib. pl. xv [bottom], p. 25.

(24) Remains of deceased with sons, and men bringing cattle. Id. ib. pl. xv [middle], p. 25.

(25) Deceased with sons Ibi , Greatest of the seers, etc., and Tetizedi.

Id. ib. pl. xvi, pp. 25, 50 [95-8]. Details of dress of deceased, BADAWY in *Gazette des Beaux-Arts*, lxxxvi (1975), fig. 5 [left] on p. 132.

Room VII. View, JAMES, pl. xviii.

(26) Doorway. (a) and (b) Five registers of offering-bringers.

Id. ib. pl. xvii [A], pp. 25-6.

(27) and (28) Deceased at table, with priests (including Ikhekhi, Lector-priest, etc., at (27)), offerings and offering-bringers (only lower part at (27)).

(27) Id. ib. pl. xx, pp. 26, 54 [118-27]. (28) Id. ib. pl. xxi, pp. 26, 53-4 [102-17]. Deceased and priests, GUNN MSS. R.14; bottom register of offering-bringers, R.3.8.

(29) False-door, and offering-table in front of it.

False-door, JAMES, pl. xix, pp. 26, 50-2 [99-101] with fig. 16; GUNN MSS. xiv. 7 [3], 14 [1] (photos.). Text on offering-table, JAMES, pl. xvii [B], p. 56 [152].

(30) (partly above doorway) Five registers, offerings, offering-bringers and butchers.

Id. ib. pl. xxii, pp. 26-7, 54-6 [128-51].

Room VIII. Store-room.

(31) Above and beside doorway, boxes and vases.

Id. ib. pl. xxiv [lower], p. 27.

(32), (33) and (34) (upper parts destroyed) Offerings before deceased with sons.

Id. ib. pls. xxiv [upper], pp. 27, 56 [153-60].

Room IX. View, id. ib. pl. xxv; GUNN MSS. xiv. 12 [2] (photo.).

(35) (upper part destroyed) Deceased with sons. JAMES, pl. xxx [B], pp. 29, 60 [195].

(36) Deceased (upper part lost) with sons, and registers of offerings, butchers and offering-bringers.

Id. ib. pl. xxxii [left], pp. 29, 60 [190-4].

(37) (partly above doorway to Room X) Offerings and offering-bringers.

Id. ib. pl. xxxii [right], pp. 29, 59-60 [187-9].

(38) Above right part of doorway, dwarf *ʿAnkhef* , Steward, handing box to deceased seated (upper part lost).

Id. ib. pl. xxxi [left], pp. 28-9, 59 [186].

(39) (partly above doorway to Room XI) Offerings and offering-bringers.

Id. ib. pl. xxxi [middle], pp. 28 [bottom], 59 [184-5].

(40) Two registers of offering-bringers. Id. ib. pl. xxxi [right], pp. 28, 59 [181-3].

(41) (top and bottom parts only) Deceased and son, with registers of men dragging [sledges].

Id. ib. pl. xxviii, pp. 28, 33, 58 [166-7], 67 [I, II]. Graffito, id. ib. pl. xxxiii, p. 58 [168].

(42) Deceased seated (upper part lost), with two men offering incense and unguent.

Id. ib. pl. xxix [upper], pp. 28, 58 [169-70].

(43) (top part damaged) Deceased, and registers of chests with collars, men with linen, and offering-bringers with animals.

Id. ib. pl. xxix [lower], pp. 28, 58 [171-4].

(44) Deceased (upper part lost) with sons and attendants, and remains of bottom register of offering-bringers with animals.

Id. ib. pl. xxx [A], pp. 28, 58-9 [175-80].

Pillars A-E. Names and titles, with deceased at bottom.

Id. ib. pls. xxvi, xxvii, pp. 27-8, 56-8 [161-5].

Unplaced blocks.

Remains of offering-list, id. ib. pl. xli [VIII], pp. 18, 22, 33, 68. Upper part of deceased, id. ib. pl. xli [VII], pp. 33, 68. Remains of name and title, see id. ib. p. 71 [248] (copied by Gunn). Three registers of brewing, id. ib. pl. xlii [XII], pp. 34, 69-70.

Burial chamber 1. Opening in Room IX.

Walls. Offerings, offering-list and text, id. ib. pls. xxxiv-xxxviii, pp. 30-2, 60-5 [196-215]; parts, GUNN MSS. xiv. 15 [1], 16 [1], 17-19 (photos.).

Sarcophagus, with address concerning closing it. GUNN MSS. xiv. 16 [2] (photo.); texts, JAMES, pl. xxxix, pp. 31-2, 65-6 [216-23]; address, FIRTH and GUNN, *Teti Pyr. Cem.* ii, pl. 58 [4]; i, p. 99; SETHE, *Urk.* i. 205 [41 (132), B].

Burial chamber 2. Another Khentka, Overseer of linen (*sšrw*), etc. Opening in Room III.

Walls. Offerings, offering-list and text, JAMES, pl. xl, pp. 14-15, 32-3 with fig. 13, 66-7 [224-34].

Shaft B. Under west wall of mastaba.

Three statuettes of nude child Ikhekhi, Sole companion, in Cairo Mus. JE 47758-60. CAPART, *Memphis*, fig. 246; RIAD, *La Médecine au temps des Pharaons*, fig. 51; BAUMGARTEL in *J.A.R.C.E.* vii (1968), pl. x [19] (as JE 6002 in error), p. 13 (as wood); JE 47760, HORNE-MANN, *Types*, i, pl. 11; see *Descr. somm.* No. 6002; JAMES, p. 4.

Finds

Upper part of male statue, in Neuchâtel Mus. Eg. 331. GABUS, *La Collection égyptologique* [etc.] in *Formes et Couleurs*, xi [1] (1949), 3rd fig. See id. *175 ans*, Pt. 1, p. 52 [top, 6]; JAMES, p. 5 [middle] (probably).



Dummy roast fowl and joints. Some, GUNN MSS. xiv. 15 [2] (photo.), xv. 3 (tracings); texts, JAMES, pp. 2-3 (from Gunn).



Jar with offering-text. Text, id. ib. p. 71 [249], cf. p. 8.

Offering-tables of Khentka (perhaps owner of Burial chamber 2) and Ishetmaç. Id. ib. pl. xli [IX, X], pp. 5, 33, 68.

False-door of Khenukhuit , King's sole adorer, Prophetess of Hathor, etc., Dyn. VI or 1st Int. Period, in front of doorway. GUNN MSS. xiv. 10 [2, cf. 1] (photos.), and Notebook, 19, pp. 26-7; see JAMES, p. 7 [lower].

Painted blocks with offering-text and oil-vases. GUNN Notebook, 12, No. 103.

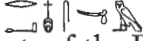
Texts of fragments of various dates, stored in mastaba at one time, id. ib. 19, pp. 15-17, 20 [lower]-22, 28-9, and offering-tables, including those of Theteti , Overseer of the Two Granaries, etc., and Methefi  Akhu , Count, etc., probably 1st Int. Period, pp. 23-5.

NEFERSEHEMRĒ  SHESHI , Chief Justice and Vizier, Inspector of prophets of the Pyramid of Teti, etc. Early Dyn. VI.

Map LII. Plan LIV.

Wife, Semdet .

CAPART, *Rue de Tombeaux*, pls. ix-xvii, pp. 17-26; plan, pl. viii (from LORET). Texts, GUNN Notebook, 2, pp. 47-63; 3, pp. 4-25. ČERNÝ Notebook, 118, pp. 21 verso-29.

Exterior.

Fragments of frieze with offering-text, FIRTH and GUNN, *Teti Pyr. Cem.* i, p. 103 [4]. (1), (2), (3) Name and titles, with deceased at bottom. Texts, id. ib. p. 103 [1-3].

Doorway.

- (4) [1st ed. 4–6] (a)–(b) Lintel with two figures of deceased and text, jambs with deceased and titles. (c) and (d) Name and titles, with deceased (lost at (d)). (e) Four registers of cattle. (a)–(b) CAPART, pl. ix. (e) Id. ib. pl. x.

Room III.

- (5) Remains of text and beginning of registers of offering-bringers.
 (6) [1st ed. 7] False-door with conventional biographical text, and kneeling men holding ointment-vessels left and right of it.
 CAPART, pl. xi, cf. fig. 2; biographical and other texts, SETHE, *Urk.* i. 198–200 [36–7 (127–8)].

Room VI.

Pillars. On all faces, deceased, also with family. CAPART, pls. xii–xvii; id. *L'Art ég.* (1911), pls. 122–3; id. *L'Art ég.* i, pl. 56.

Burial chamber. FIRTH and GUNN, op. cit. i, pp. 18–19; plan and section, fig. 12.

Sarcophagus. Texts, id. ib. ii, pl. 58 [5, 6]; i, pp. 103–4 [ii].

‘ANKHMA‘HOR  SESI , Chief Justice and Vizier, Inspector of prophets and Tenant of the Pyramid of Teti, etc. Early Dyn. VI.

Map LII. Plan L.

CAPART, *Rue de Tombeaux*, pls. xix–lxxiii, with plan, pl. xviii (from LORET). Texts, GUNN Notebook, 1, passim; 2, pp. 1–45; ČERNÝ Notebook, 118, pp. 30–51; some, DAVIES MSS. 2. 110. To be published by BADAWEY.

Room I.

(1) [1st ed. 1–4] Doorway. (a) and (b) Deceased; (c) and (d) address, and conventional biographical phrases, with deceased seated at bottom; (e) and (f) deceased as fat man.

CAPART, pls. xix–xxiv. (a) and (c) Id. *Memphis*, fig. 226. Upper part of deceased at (c), BADAWEY in *Gazette des Beaux-Arts*, lxxxvi (1975), fig. 1 on p. 129. Texts at (c) and (d), SETHE, *Urk.* i. 201–3 [39 (130), A, B]; GARDINER MSS. 29.62.

(2) [1st ed. 5] Remaining registers, I, winnowing, stacking straw, bringing donkeys, II, cattle crossing water, with herdsmen in canoes reciting charm against crocodiles.

CAPART, pls. xxvii–xxx; WRESZ., *Atlas*, iii. 52. Right part, CAPART, *Memphis*, fig. 224; HICKMANN in *Ä.Z.* 83 (1958), Taf. x [b] (from CAPART), p. 121.

(3) Remains of estates.

Names, JACQUET-GORDON, *Domaines*, p. 407 [32S6], Nos. 1–7, cf. figs. 166–7. See CAPART, p. 31.

(4) [1st ed. 6] Bottom remaining register, crocodile, hippopotami, and fish.

Id. ib. pl. xxvi. Parts, id. *Memphis*, fig. 380; WRESZ., *Atlas*, iii. 92 [B].

(5) [1st ed. 7] Two registers, baking, brewing and scribes recording.

CAPART, pl. xxv; WRESZ., *Atlas*, iii. 72.

Room II.

(6) [1st ed. 8, 9] Doorway. (a) and (b) At bottom, remains of market-scenes.

Id. ib. 118; CAPART, pls. xxxi, xxxii.

(7) [1st ed. 10] Registers, **I**, [craftsmen], **II**, sculptors and metal-workers, **III**, jewellers (including dwarfs), leather-workers and vase-makers.

Id. ib. pl. xxxiii; WRESZ., *Atlas*, iii. 34. Omitting right end, BADAWY in *I.L.N.* Sept. 1975, fig. on p. 63 [upper]. Right part of **II-III**, and left part of **III**, id. in *Gazette des Beaux-Arts*, lxxxvi (1975), figs. 7, 8 on pp. 133-4.

(8) [1st ed. 11] Deceased (upper part lost) and son Ishefi , with attendants (including dwarf with monkey) behind, and remains of bottom registers, **I** (almost completely lost), **II-III**, netting fowl, with men bringing birds, and pulling rope of clap-net in **II**, and waiting for birds to enter clap-net in **III**.

CAPART, pls. xxxiv-xli. Omitting deceased and attendants, WRESZ., *Atlas*, iii. 74; VON BISSING, *Denkmäler*, i, Taf. 18A. Dwarf with monkey, WATERMANN, *Bilder aus dem Lande des Ptah und Imhotep*, Abb. 30. Details of netting-scene, CAPART, *Memphis*, fig. 375; id. *L'Art ég.* iii, pl. 455; id. *L'Art ég.* (1909), pl. 24; id. *Propos*, fig. 28; FECHHEIMER, *Plastik* (1914), Taf. 132; (1923), Taf. 142; STRÖMBOM, *Egyptens Konst*, fig. 69.

(9) [1st ed. 12] Remains of three registers (top almost completely lost), attendants and offering-bringers.

CAPART, pls. xlii, xliii.

Room III.

(10) [1st ed. 13, 14] Doorway. (a) Registers, **I** and **III**, bringing wild animals, **II**, overthrowing bull; (b) registers, **I**, overthrowing bull, **II**, bringing oryx and gazelle.

(a) CAPART, pl. xlv. (b) Id. ib. pl. xlv; LAUER, *Saqqara*, pl. 52; **I**, WEIGALL, *Anc. Eg. . . . Art*, 71 [upper] (reversed); FECHHEIMER, *Plastik* (1914), Taf. 131; (1923), Taf. 141 (reversed).

(11) [1st ed. 15] Deceased, and three registers of offering-bringers.

CAPART, pl. xlvi. Deceased, BADAWY in *Gazette des Beaux-Arts*, lxxxvi (1975), figs. 5 [4th from right], 6 on p. 132.

(12) [1st ed. 16] Brother Themru  and [son of deceased] (erased) before deceased (upper part destroyed) with three sons.

CAPART, pls. xlix, l. Themru, BADAWY, op. cit. fig. 2 on p. 130. Text of [son], SETHE, *Urk.* i. 203 [39 (130), C].

(13) [1st ed. 17] Deceased with two small men (one of them Themru), and three registers of offering-bringers.

Offering-bringer with geese and gazelles, CAPART, pl. xlvi.

(14) [1st ed. 18] Deceased (almost completely destroyed) with son, and three registers of offering-bringers.

Id. ib. pl. xlvi.

Room IV.

(15) [1st ed. 19, 20] Doorway. (a) and (b) Three registers of offering-bringers (only feet from top register at (b)) with animals.

Id. ib. pls. li, lii.

(16) [1st ed. 21] Three remaining registers of butchers.

Id. ib. pls. liii-lvi. One group in bottom register, WRESZ., *Atlas*, iii. 94 [B]. Detail, MONTET, *Scènes*, fig. 30 [left] on p. 170. Some texts from second register, id. ib. pp. 156 [3], 170 [3], 175-7.

(17) [1st ed. 22-3] Three registers of offering-bringers, some with animals.

CAPART, pls. lvii-lix.

(18) [1st ed. 24-5] Three registers of offering-bringers, mostly with animals.

Id. ib. pls. lx–lxii. Four last offering-bringers in bottom register, id. *Memphis*, fig. 348; two last, WEYNANTS-RONDAY in *Chron. d'Ég.* xv (1940), fig. 3 on p. 57. Gazelles brought by 5th man from right, BADAWY in *I.L.N.* Sept. 1975, fig. on p. 63 [right lower].

Room V.

(19) [1st ed. 26–7] Doorway. (a) and (b) Registers, **I–III**, men bringing vases, jewelry and cloth.

CAPART, pls. lxiii, lxiv. First man in **I** at (a), BADAWY in *Gazette des Beaux-Arts*, lxxxvi (1975), fig. 3 on p. 131.

(20) [1st ed. 28] Deceased, with three registers of men bringing chests.

Two bottom registers, CAPART, pl. lxxv. Names of four phylai, SETHE, *Urk.* i. 203 [39 (130), D].

Room VI.

(21) [1st ed. 29, 30] Doorway. (a) Two registers, surgical operations on hand and foot, with chests above each of them; (b) two registers, operations on leg and neck, and circumcision; (c) deceased.

(a) CAPART, pl. lxxvii; MÜLLER (W. M.), *Egyptological Researches*, i, pl. 105; WRESZ., *Atlas*, iii. 24; LAUER, *Saqqara*, pl. 51. Lower register and chests above, GHALIOUNGUI, *Magic and Medical Science* (1963), pl. x; (1973), pl. 18 (latter reversed).

(b) CAPART, pl. lxxvi; MÜLLER (W. M.), op. cit. pl. 106, fig. on p. 61; WRESZ., *Atlas*, iii. 25–6; RIAD, *La Médecine au temps des Pharaons*, fig. 50; SIGERIST, *A History of Medicine*, i, pl. xxvii [58] (cast); BADAWY in *I.L.N.* Sept. 1975, fig. on p. 63 [left lower]. Circumcision-scenes, DAUMAS, *Civ. de l'Ég.* pl. 90; ROWLING in BROTHWELL and SANDISON, *Diseases in Antiquity*, fig. 1 on p. 536; JONCKHEERE, *La Circoncision* [etc.] in *Centaurus*, i (1951), fig. 2 (from CAPART), p. 224; PILLET in *Ann. Serv.* lii (1954), pl. vi, fig. 10, pp. 96–9; PRITCHARD, *Anc. Near East*, fig. 629; LAUER, *Saqqara*, pl. 50; group on right, POSENER, SAUNERON and YOYOTTE, *Dict. civ.* fig. on p. 56; CURTO, *Medicina e Medici nell'Antico Egitto*, 3rd fig.; LECA, *Médecine*, pl. xvi facing p. 432; GHALIOUNGUI, op. cit. (1973), pl. 17; group on left, DE WIT in *Ä.Z.* 99 (1972–3), fig. 1, p. 45.

(22) [1st ed. 31–2] Registers, **I** (from left), priests, and men carrying [coffin], **II** (from right), men carrying [coffin], priests, and two sub-registers with mourners before house of deceased.

CAPART, pls. lxx–lxxii; LÜDDECKENS in *Mitt. Kairo*, II (1943), Abb. 6a, 7 [right], pp. 7, 17–18 [2]. Omitting right end, LAUER, *Saqqara*, pl. 54. Priests in **I** and mourners in **II**, GHALIOUNGUI, op. cit. (1963), pl. xi. Mourners, VON BISSING, *Denkmäler*, i, Taf. 18B; WERBROUCK, *Pleureuses*, figs. 2, 71–4, 80–5, 156, 158–9, 161–3, cf. p. 17 and figs. on p. 160; some, FECHHEIMER, *Plastik* (1914), Taf. 133; (1923), Taf. 143; STRÖMBOM, *Egyptens Konst*, fig. 70; WEIGALL, *Anc. Eg. . . . Art*, 71 [lower]; SAMEH, *Daily Life*, figs. on pp. 109, 119; group with fainting woman, WENIG, *Die Frau*, pl. 18; female mourner and group with fainting man, SCHÄFER in *Ä.Z.* 73 (1937), Abb. 2, 4, pp. 102–3, 104–6.

(23) [1st ed. 33] [Deceased seated], and two girls clapping and five girl acrobats in bottom register.

CAPART, pls. lxxviii, lxxix; almost complete, LAUER, *Saqqara*, pl. 53. Two acrobats, CAPART, *Memphis*, fig. 388; FECHHEIMER, *Plastik* (1914), Taf. 134; (1923), Taf. 144; VON BISSING, *Die Kultur des alten Ägyptens*, Taf. 2 [4]; WRESZ., *Bericht*, Taf. 77 [middle] (called Ššj).

(24) [Deceased], and two registers with two sons (one erased) in each behind him.

(25) Remains of deceased watching boats.

Pillars. Deceased, with names and titles.

VII. Offering-room of eldest son Ishefi Tutu .

(26) [1st ed. 34] False-door. CAPART, pl. lxxiii.

Burial chamber.



FIRTH and GUNN, *Teti Pyr. Cem.* i, pp. 16-18, with plan and section, fig. 9.

Walls. Offering-list, offerings and funerary equipment; id. ib. ii, pl. 6; texts, i, pp. 93-8 [I].

Sarcophagus, with address concerning closing it. Texts, id. ib. ii, pl. 58 [1-3]; i, pp. 98-101 [II]; SETHE, *Urk.* i. 204-5 [41 (132), A].

Ointment-slab, alabaster, in Cairo Mus. JE 47033. FIRTH and GUNN, op. cit. ii, pl. 13 [D]; i, pp. 18 [i], 102.

Base of head-rest, alabaster. Id. ib. ii, pl. 14 [2]; i, pp. 18 [v], 102.

UZAḤATETI  NEFERSEHEMPTAḤ  SHESHI 
Inspector of prophets of the Pyramid-town of Teti, Tenant of the Pyramid of Teti, etc. Early Dyn. VI.

Map LII. Plan LIV.

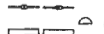
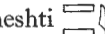
Wife, Seshseshet  Sheshti , King's daughter of his body.

CAPART, *Rue de Tombeaux*, pls. lxxv-ci; plan, pl. lxxiv (from LORET). Texts, ČERNÝ Notebook, 118, pp. 52-63; collated parts at (2)-(4), GUNN Notebook, 3, pp. 41-9.

Façade.

(1) Deceased. CAPART, pl. lxxv.

(2) Offering-text. Id. ib. pl. lxxvi [left].

(3) Conventional biographical text.

Id. ib. pl. lxxvii [right]. Text, SETHE, *Urk.* i. 200-1 [38 (129)]; cf. EDEL in *Mitt. Kairo*, 13 (1944), pp. 70-2.

Room I.

(4) [1st ed. 4-7] Doorway. (a) and (b) Name and titles, with deceased at bottom; (c) and (d) deceased as fat man.

CAPART, pls. lxxvi [right], lxxvii [left], lxxviii, lxxix.

Room II.

(5) [1st ed. 8, 9] Doorway. (a) and (b) Four registers of men bringing animals.

Id. ib. pls. lxxx, lxxxi. (b) I-III, CHAMPDOR, *L'Égypte des Pharaons*, pl. on p. 25; ZADOKS-JOSEPHUS JITTA, *Het Nabije Oosten*, pl. 12; II, WRESZ., *Bericht*, Taf. 75 [B].

(6) [1st ed. 10] Registers, I, man in boat angling (rest destroyed), II-III, offering-bringers. I, id. *Atlas*, iii. 92 [D]. II-III, CAPART, pl. lxxxii.

(7) [1st ed. 11] Three registers of offering-bringers with hedgehogs and birds in boxes, etc.

Id. ib. pls. lxxxiii [left], lxxxiv.

(8) [1st ed. 12] Registers, I, men bringing fish, II, offering-bringers in canoes, III-IV, offering-bringers.

Id. ib. pl. lxxxiii [right]. I-II, WRESZ., *Atlas*, iii. 116 [A].

(9) [1st ed. 13-14] Registers, I (with two sub-registers), II-III (narrow), feeding fowl,

IV, taking birds out of clap-net, with sub-registers of roasting and plucking fowl and men pulling rope, V, scribes and scenes of feeding fowl in fowl-yard, VI, two men with birds and others ready to close clap-net.

CAPART, pls. lxxxv-lxxxix; WRESZ., *Atlas*, iii. 80-1. II-IV (incomplete), ANGIOLETTI and BIGONGIARI, *Testimone*, Tav. 25; FAVRE, *L'Arte*, fig. on p. 15. Man feeding pigeon in II, SMITH, *Hist. Eg. Sculp.* fig. 127a [middle], p. 284; feeding cranes in III, SCHÜZ, *Über Stelzvögel* [etc.] in *Die Vogelwarte*, 23 (1966), Abb. 11 on p. 273. IV-VI, MÜLLER, *Äg. Kunst*, Abb. 44-5. IV, man plucking bird, SMITH, op. cit. fig. 134, p. 287; taking out birds, CAPART, *Memphis*, fig. 258. Scribes and left scene of feeding fowl in V and men in VI, id. ib. fig. 376; id. *L'Art ég.* iii, pl. 457; LANGE, *Ägypten. Landschaft*, pl. 47.

Room III.

(10) [1st ed. 15, 16] (a) and (b) Deceased and wife, and two registers of offering-bringers.

CAPART, pls. xc-xciii.

(11) [1st ed. 23] Deceased at table, with wife squatting, [offering-list] and offerings, and butchers below.

Id. ib. pl. ci.

(12) [1st ed. 17-18] Deceased at table, with offerings and offering-bringers.

Id. ib. pls. xcix, c.

(13) [1st ed. 21-2] Deceased at table, with wife squatting, [offering-list], offerings, priests and offering-bringers.

Id. ib. pls. xcvi, xcvi.



(14) [1st ed. 19-20] False-door, with statue cut in both outer jambs, bust in place of panel, and six vases with oils on either side.

Id. ib. pls. xciv-xcvi; id. *L'Art ég.* i, pl. 54; id. *Memphis*, fig. 307; JÉQUIER, *Hist. civ.* fig. 112; FECHHEIMER, *Plastik*, Taf. 12; LUGN, *Kunst*, fig. 10; HAMANN, *Äg. Kunst*, Abb. 145; SENK in *Forschungen und Fortschritte*, 33 (1959), Abb. 6, p. 240 note 35; WOLF, *Kunst*, Abb. 219; SCHÄFER, *Von äg. Kunst* (1963), Taf. 18 [2]; Eng. ed. *Principles of Egyptian Art*, pl. 31; incomplete, MASPERO, *Guide* (1914), fig. 3, p. 16; (1915), fig. 6, p. 17; id. *Égypte*, fig. 62; MORET, *Au temps des Pharaons*, pl. xiii [1]; id. *In the Time of the Pharaohs*, pl. xiii [1].

TOMB WITH SEVERAL BURIAL CHAMBERS. 1st Int. Period.

Map LII.

Excavated by Lepsius in 1843.

Jamb of Reky , Treasurer of the God, etc., with 'Ankhef  censing to deceased at bottom. L. *D. Text*, i, p. 147 with note 1, cf. fig. on p. 146 [b]; FIRTH and GUNN, *Teti Pyr. Cem.* ii, pl. 76 [1]; i, p. 211 [22].

Two fragments with five figures of Reky. CAIRO, CENTRE OF DOCUMENTATION photo. S.A., 2768.

Burial chamber 1. Numbers are those of Berlin Museum.

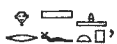
Head-rest of Ḥarshefhotp , wood, from shaft above burial chamber, No. 1310. L. *D. Text*, i, fig. 2 on p. 150; text, p. 151 [near bottom]; *Aeg. Inschr.* i, p. 135. See *Ausf. Verz.* p. 75.

Rectangular wooden coffins and their contents. L. D. *Text*, i, pp. 147-51.

(a) Ipi'ankhu . Foot-board, No. 10183 (East); text, id. ib. p. 147 [near bottom]; *Aeg. Inschr.* i, p. 135.

(b) Khuit-khentekhtai  Khuit (woman). Coffin-texts, L. D. ii. 99 [a], *Text*, i, p. 148 note 1. Foot-board, No. 10616 (East); text, id. ib. p. 148 [near top]; *Aeg. Inschr.* i, p. 130. Fragment of lid, No. 10185 (East), see L. D. *Text*, i, p. 148 [near top].

Head-rest, wood, No. 1312 (West). L. D. *Text*, i, fig. 3 on p. 150; text, p. 148 [top]; *Aeg. Inschr.* i, p. 135. See *Ausf. Verz.* p. 74.

(c) Ipi'ankhu, Overseer of 'Hair of the Earth', etc. Inner coffin, and planks from lid of outer coffin, Nos. 10184-5 (East). No. 10184, L. D. ii. 98, *Text*, i, pp. 148 [near bottom] with note 2, 149; texts, *Aeg. Inschr.* i, pp. 125-30; see *Ausf. Verz.* p. 73. No. 10185, L. D. ii. 99 [b].

Burial chamber 2. Gemni , Overseer of the seal (?).

Coffin, wood. Name and title, L. D. *Text*, i, p. 157 [top].

Head-rest, alabaster, in Berlin (West) Mus. 1309. Id. ib. fig. 5 on p. 150, cf. pp. 154, 157 [top right]; KAISER, *Äg. Mus. Berlin* (1967), p. 30 [263] with Abb.; SCHÄFER and ANDRAE, *Kunst* (1925), 299 [2]; (1930 and 1942), 311 [2]. Text, *Aeg. Inschr.* i, p. 135. See *Ausf. Verz.* p. 75.

Model rowing-boat, wood, in Berlin (West) Mus. 1289. L. D. *Ergänz.* xlv [upper]. See *Ausf. Verz.* p. 75.

Model kitchen, wood, in Berlin (West) Mus. 1366. L. D. *Ergänz.* xlvi [top]. See BREASTED (Jr.), *Eg. Servant Statues*, p. 46 [4]; *Ausf. Verz.* p. 76.

Burial chamber 3.

Model boat, wood, in Berlin (West) Mus. 1232. L. D. *Ergänz.* xlv [lower], cf. *Text*, i, p. 157 [near top]. See *Ausf. Verz.* pp. 75-6.

GEMNIUSER , Royal chamberlain, Scribe. 1st Int. Period.

Wife, Sithasib .

Near north-east corner of tomb of Kagemni. Not marked on map.

L. D. *Text*, i, pp. 158-9.

Coffins. Wooden, rectangular. Numbers are those of Berlin Mus.

Deceased; two planks, Nos. 13101-2 (East); texts, id. ib. p. 158 [middle]; *Aeg. Inschr.* i, p. 135. Wife; two planks, Nos. 13103-4 (East); texts, L. D. *Text*, i, p. 158 [middle]; *Aeg. Inschr.* i, p. 134.

Funerary equipment and models. Wood. Numbers are those of Berlin Mus.

Head-rest of deceased, No. 1307. L. D. *Text*, i, fig. 4 on p. 150; text, p. 158 [bottom left]; *Aeg. Inschr.* i, p. 135. See *Ausf. Verz.* p. 75.

Statuette of deceased, No. 1363 (West). L. D. *Ergänz.* on xlvi; KAISER, *Äg. Mus. Berlin* (1967), pp. 34-5 [302] with Abb.; text, L. D. *Text*, i, p. 158 [bottom right]; *Aeg. Inschr.* i, p. 135. See *Ausf. Verz.* p. 75.

Model granary. Man gathering grain and another carrying basket, Nos. 1364-5 (West); L. D. *Ergänz.* on xlvi; see *Ausf. Verz.* p. 76. Text on scribe's board, L. D. *Text*, i, p. 159 [upper left].

PTAḤSHEPSES , Count, Inspector of prophets of the Pyramid of Teti, etc. Middle Dyn. VI or later.

Map LII.

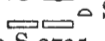
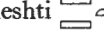
Wife, Seshseshet  Sheshti , King's daughter of his body.
Covered by tomb S 2735.

QUIBELL and HAYTER, *Teti Pyramid, North Side*, pp. 20-3; section, fig. on p. 21.

South-east room.

Remains of painted decoration of north wall, with deceased and wife.

South-west room.

False-door of Khnemḥotp and offering-basin of Khuwi . False-door, CAIRO, CENTRE OF DOCUMENTATION photos. S.A., 2616-17.

Offering-room. Painted decoration.

East wall. Offerings and butchers, with four vases on each side of doorway.

South wall. Deceased seated, with offerings and offering-bringers.

West wall. False-door.

North wall. Deceased at table, with priests and offering-bringers.

MERERI , Count, Overseer of the department of tenants of the Great House, etc. Middle Dyn. VI.

Map LII. Plan LV.

Wife, Iny , Prophetess of Ḥathor, etc.

SAAD in *Ann. Serv.* xliii (1943), p. 454. Description, texts and titles, DRIOTON in *ib.* pp. 488-96; plan, pl. xlvii [A].

Exterior.

(1) False-door. Texts, *id. ib.* pp. 489-92.

Outer Hall.

(2) Doorway. (a)-(b) Lintel with offering-text, jambs with titles and deceased.

SAAD in *ib.* pl. xxxix [A], p. 454.

(3) Marsh scene, deceased with wife spearing fish, sons and dwarf with box behind, and offering-bringers.

See DRIOTON in *ib.* p. 492 [a]. Dwarf, SAAD in *ib.* pl. xxxix [B], p. 454.

(4) Six registers, scene of rendering accounts, feeding gazelle, cattle and fowl, bringing birds, poultry-yard.

Texts of III-VI, DRIOTON in *ib.* pp. 492-3 [b].

(5) Four registers, an official in each. Texts, *id. ib.* p. 493 [c].

(6) Five registers of offering-bringers before deceased and two sons. See *id. ib.* p. 493 [d].

(7) (above doorway) Two registers, goats, and preparation of fish. See *id. ib.* p. 493 [e].

(8) Six registers of offering-bringers before deceased and son. See *id. ib.* p. 493 [f].

Inner Hall.





(9) (preliminary sketch) Butchers. See *id. ib.* p. 494 [j].



(10) and (11) Deceased at table, with offering-list and offering-bringers.

Texts of offering-bringers, id. ib. p. 494 [i, h].

(12) False-door. Texts, id. ib. pp. 493-4 [g].

Brick-built room against south face of mastaba.

False-door of Nebt  Iby   , Prophetess of Hathor in all her places, etc. SAAD in ib. pl. xl, p. 454; texts, DRIOTON in ib. pp. 495-6 [k].

WERNU  , Tenant of the Pyramid of Teti, Lector-priest of the *mit*-bark of Horus and the *dst*-bark of Horus, etc. Middle Dyn. VI or later.

Map LII. Plan LV.

SAAD in *Ann. Serv.* xliii (1943), p. 455. Description, texts and titles, DRIOTON in ib. pp. 496-501; plan, pl. xlvii [B]. Titles, JUNKER in ib. xlix (1949), pp. 207-15.

Hall.

(1) Thickness of doorway. Deceased. See DRIOTON, op. cit. p. 498 [middle].

(2)-(3) Upper part, marsh scene (destroyed). Lower part, offering-bringers in boats and butchers.

Texts, id. ib. p. 501 [g, h, i].

(4) Two remaining registers, offering-bringers before statues. Texts, id. ib. p. 501 [f].



(5) and (7) Five columns of titles, with deceased at bottom.

Columns of text, SAAD in ib. pl. xlii, p. 455; DRIOTON in ib. fig. 67, p. 500 [c, d].

(6) False-door. SAAD in ib. pl. xli, p. 455. Texts, DRIOTON in ib. pp. 498-9 [b].

(8) Remaining registers before [deceased], I-III, men bringing wild animals, with hedgehog, and lion attacking oryx at right end of I.

SAAD in ib. pl. xliii, p. 455. Texts, DRIOTON in ib. p. 501 [e].

KHUI  , Tenant of the Pyramid of Teti, Prophet of the Pyramid of Pepy I, Overseer of Upper Egypt, etc. Middle Dyn. VI or later.

Map LII.

SAAD in *Ann. Serv.* xliii (1943), pp. 455-6. Description, texts and titles, DRIOTON in ib. pp. 502-4; plan, pl. xlvii [C].



Outer Hall.

Doorway. Lintel with double-scene, deceased twice on either side; jambs, son censuring before deceased; thicknesses, address, with man censuring before deceased at bottom.

Lintel and jambs, SAAD in ib. pl. xlv, p. 456. Texts, DRIOTON in ib. pp. 503-4.

Inner Hall.

False-door. See id. ib. p. 504 [c].

THETUT  , King's [secretary] of all secret commands of the frontier-posts, etc. Dyn. VI.

Map LII.

Description, texts and titles, DRIOTON in *Ann. Serv.* xliii (1943), pp. 504-5; plan, pl. xlvii [D].

Exterior, left of entrance doorway.

Deceased and son Teti^cankh  ♀^c, and remains of address. Texts, id. ib. p. 505.

Two obelisks. Name and title on one, id. ib. p. 505.

DESI , Noble of the King, Companion of the house. Dyn. VI.

Map LII.

Wife (name lost), Prophetess of Hathor Mistress of the Sycamore.





Description, texts and titles, DRIOTON in *Ann. Serv.* xliii (1943), pp. 505-6; plan, pl. xlvii [E].

Outer Hall.

Doorway. Lintel-fragment with remains of text mentioning Pepy (probably I) and series of figures of deceased; left jamb, deceased (twice) with son. Text, id. ib. p. 506.

Inner Hall.

Upper part of false-door, and fragments of another of wife. See id. ib. p. 506.

MERU  TETISONB  (also MERYRĒ^cSONB  and PEPEYSONB , Overseer of commissions of tenants of the Pyramid of Teti, Supervisor of prophets of the *mert*-temple of Teti, etc. Temp. Pepy I or later.

Map LII. Plan LV.

Description and titles, DRIOTON in *Ann. Serv.* xliii (1943), pp. 506-9; plan, pl. xlvii [F].

Entrance doorway.

(1) (a) and (b) Deceased.

Outer Hall.

(2) Marsh-scene with deceased fowling. (3) Deceased (much damaged) in palanquin with sunshade.

Inner Hall.

(4) Deceased watching three registers of destroyed scenes, with feeding cattle, cattle crossing water, netting fish. (5) Deceased at table, offering-list, and offering-bringers. (6) False-door, with list of oils on either side. (7) Deceased at table, with offering-bringers. (8) Deceased, and three registers, flax-growing, two men with birds and men in canoes, and butchers.

SEMDENT , Prophet of the Pyramid of Teti, etc. Dyn. VI.

Map LII.

SAAD in *Ann. Serv.* xliii (1943), pp. 456-7. Description, texts and titles, DRIOTON in ib. pp. 509-11; plan, pl. xlvii [G].

Entrance doorway.

Left jamb, feet of deceased and remains of text; left thickness, man leading oryx. Text, id. ib. p. 510 [near bottom].

Outer Hall.

Left of doorway to Inner Hall, remains of painted scene with chests and collars. SAAD in ib. pl. xlv, p. 456; see DRIOTON in ib. p. 510 [bottom].

Inner Hall.

Doorway. Thicknesses, remains of painted scenes of men bringing cattle. See id. ib. p. 511 [near top].

False-door. SAAD in ib. pl. xlvi, pp. 456-7; see DRIOTON in ib. p. 511.

NAME LOST, Royal chamberlain of the Great House, etc. Dyn. VI.

Map LII.

DRIOTON in *Ann. Serv.* xliii (1943), pp. 512-13; plan, pl. xlvii [H].

Hall. Painted decoration, much destroyed.

North wall. Deceased at table, offering-list, and offering-bringers. Texts, id. ib. p. 512 [a].

East wall. Four (top destroyed) registers of offerings and offering-bringers before deceased and wife. Texts, id. ib. p. 513 [b].

LS 10. KAGEMNI  MEMI  (also GEMNI ) , Chief Justice and Vizier, Overseer of the Pyramid-town of Teti, etc. Temp. Teti.

Plan LV.

Wife, Nebty-nubkhet  Seshseshet  , King's daughter of his body.

Inner part, VON BISSING, *Die Mastaba des Gem-ni-kai*, i, ii [1]; outer part, FIRTH and GUNN, *Teti Pyr. Cem.* i, pp. 20-1. See DARESSY in *Rev. Arch.* 3 Sér. xxix (1896), pp. 328-30; L. D. *Text*, i, pp. 159-60, cf. sketch-plans on pp. 145-6 [a]. Plan, FIRTH and GUNN, ii, on pl. 51; with sections, VON BISSING, i, on Taf. i. Details, id. ib. i, Taf. xxv-xxix; graffiti, Taf. xxx [1-5]. Titles, FIRTH and GUNN, i, pp. 105-8. Two rooms in shape of boats, see id. ib. i, p. 21; HASSAN, *Giza*, vi [1], p. 88.

Façade.

Fragments of frieze-text with names and titles. Texts, FIRTH and GUNN, i, p. 111 [5, 6].

(1), (2) [1st ed. 1] and (3) [1st ed. 2] Name and titles, with deceased seated at bottom.

(1) SAAD in *Ann. Serv.* xliii (1943), pl. xxxvi [left], pp. 451-2. (2) and (3) L. D. ii. 97 [b], *Text*, i, p. 159; GUNN MSS. xviii. 1 (photo.); texts, FIRTH and GUNN, i, pp. 108-9 [1].

(4) [1st ed. 3] Lower part of false-door. Id. ib. ii, pls. 5 [D], 10 [lower]; i, p. 109 [2].

(5) [1st ed. 4] Two figures of deceased seated, and remains of autobiographical text.

Id. ib. ii, pls. 7 [lower], 59 [2]; i, pp. 109-11 [3]; text, SETHE, *Urk.* i. 194-6 [33 (124), A, B]; cf. EDEL in *Mitt. Kairo*, 13 (1944), pp. 68-70. Block found later and reconstruction of text, id. in *Mitteilungen des Instituts für Orientforschung*, i (1953), Taf. i, ii, pp. 210-26.

(6) [1st ed. 5] Remains of deceased seated and autobiographical text.

FIRTH and GUNN, ii, pl. 59 [3]; i, p. 111 [4]. Text, SETHE, *Urk.* i. 196 [33 (124), C, D].

Vestibule I.

(7) [1st ed. 6-12] Doorway. (a)-(b) Lintel with double-scene of [deceased seated], drum with name and titles, and deceased on jambs; (c) and (d) deceased as fat man; (e) two men with vegetables and fowl; (f)-(g) lintel and jamb (g), name and titles.

(a)-(b) FIRTH and GUNN, ii, pls. 10 [upper], 59 [1]; i, p. 112 [7-9]; GUNN MSS. xviii. 2 [1], 3 [1] (photos.). (d) Id. ib. 2 [2] (photo.). Texts of (c) and (d), FIRTH and GUNN, i, p. 112 [10]. (e) Name of one man, id. ib. i, p. 112 [3]. (f)-(g) Texts, id. ib. i, p. 112 [1, 2].

(8) [1st ed. 13] (top part lost) Offering-bringers in two canoes, and fish below.

Id. ib. ii, pl. 53 [4]; WRESZ., *Atlas*, iii. 116 [B]; HICKMANN, *Die kultische Verwendung der altägyptischen Trompete in Die Welt des Orients*, i (1950), Taf. 16 [A], p. 351; id. *Ägypten*, Abb. 18; id. *45 Siècles*, pl. xvii.

(9) [1st ed. 14] Bottom of marsh scene with deceased in canoe, and men netting fish and angling.

FIRTH and GUNN, ii, pl. 53 [2]; i, p. 112; WRESZ., *Atlas*, iii. 97 [A].

(10) [1st ed. 15] Two men carrying jars on stands(?).

Names and titles, FIRTH and GUNN, i, p. 113 [5].

Room II.

East wall. Graffito of Idu , Sole companion, and son Gemni. Text, id. ib. i, p. 116 [11].

Pillared Hall III. 'Vorhalle' of von Bissing.

(11) [1st ed. 16-17] Bottom part, deceased, with scribes handing in lists and scene of rendering accounts, and boats with animals and grain, with other animals and fowl above.

Id. ib. ii, pl. 53 [1]; i, p. 113 [7]; right part, WRESZ., *Atlas*, iii. 68 [B]; left, 109 [A].

(12) [1st ed. 18-19] Remains of deceased, one upper register of making papyrus canoes, and two bottom registers, milking, lassoing cow, mat-making, feeding puppy, and cattle crossing canal with herdsmen in boats.

Upper register, FIRTH and GUNN, ii, p. 9 [B]; i, pp. 114-15 [9]; WRESZ., *Atlas*, iii. 38; GUNN MSS. xviii. 4 (photos.). Texts, including those of register below, ČERNÝ Notebook, 118, p. 96 [bottom].

Remains of deceased and bottom registers, FIRTH and GUNN, ii, pls. 7 [upper], 52, cf. 50; i, pp. 113-14 [8]. Registers, WRESZ., *Atlas*, iii. 92 [A, left and middle]. Left part of bottom register, LAUER, *Saqqara*, pl. 45. Milking, lassoing cow, man making mat, and herdsmen with cattle, MICHAŁOWSKI, *Piramidy i mastaby*, pls. 16, 17. Feeding puppy, LAUER, op. cit. pl. 46. Cattle with fish and hippopotamus below, BOULAT, *A Close Up of Egypt*, pls. 52-3; heads of four cows, SÉE, *Naissance*, fig. on p. 201 (called Mereruka).

(13) [1st ed. 20-1] Bottom of two scenes with deceased in canoe fishing and fowling, with men harpooning hippopotami between them, and netting fish with small net and angling from canoe on right.

WRESZ., *Atlas*, iii. 92 [A, right], 108 [A, D]. Detail of canoe of deceased on right, with fish and hippopotamus, LANDSTRÖM, *Ships of the Pharaohs*, fig. 295. Netting and angling, VON BISSING, i, Taf. iv; DE RACHEWILTZ, *L'Arte*, Tav. 45; FAVRE, *L'Arte*, fig. on p. 47; DAUMAS in *B.I.F.A.O.* lxii (1964), fig. 3, pp. 67, 73; TOUNY and WENIG, *Sport*, Taf. 53; angling, LAUER, *Saqqara*, pl. 44.

(14) [1st ed. 22] Remains of scene before [deceased].

Two metal-blowers, VON BISSING, i, Taf. xxx [6]. Name and title of deceased, FIRTH and GUNN, i, p. 115 [10].

(15) [1st ed. 23-4] Bottom register with female acrobats and clappers and male dancers.

Id. ib. ii, pl. 53 [3]; i, p. 113 [6] (text). Acrobats and clappers, WRESZ., *Atlas*, iii, 31 [upper]; LAUER, *Saqqara*, pl. 43; two acrobats and two clappers, CAPART, *Memphis*, fig. 387; GALASSI, *Tehenu*, fig. 112; id. in *Critica d'Arte*, n.s. ii (1955), fig. 263, p. 314; PIJOÁN, *Summa Artis*, iii (1945), fig. 16; HICKMANN in *Bull. Inst. Ég.* xxxvii [1] (1954-5), fig. 22, p. 186; id. *Musicologie pharaonique*, fig. 22, p. 148; id. *45 Siècles*, pl. xviii; ANGIOLETTI and BIGONGIARI, *Testimone*, Tav. 23; acrobat and clapper, CHAMPDOR, *L'Égypte des Pharaons*, pl. on p. 14. Two acrobats, WRESZ., *Bericht*, Taf. 77 [bottom]. Text, ČERNÝ Notebook, 118, at beginning.

(16) [1st ed. 26] Pillar. On all faces, remains of deceased.

Lower part of deceased on one, VON BISSING, i, Taf. iii [1].

Room IV. I of von Bissing.

(17) [1st ed. 27, 28 incorrectly placed] Doorway. (a) Men with furniture, (b) with vases.

Id. ib. i, Taf. v. Head of man on left at (a) and text above, PILLET in *R.E.A.* i (1927), fig. 1 on p. 157.

(18) [1st ed. 29 incorrectly placed] Men dragging statue.

VON BISSING, i, Taf. vi.

(19) [1st ed. 32 incorrectly placed] At bottom, female offering-bringers.

Id. ib. i, Taf. vii [2].

(20) [1st ed. 30] Deceased, and registers, **I-III**, scribes with lists, and sub-registers of men bringing [goats], tending cattle, and bringing and fattening hyenas, **IV**, men feeding fowl, **V**, two men with birds and fish, and feeding fowl in poultry-yard, **VI**, men bringing fowl, and two scenes of netting fowl.

Id. ib. i, Taf. viii-xvi. Deceased, id. *Äg. Kunstgeschichte*, Taf. xviiiA [467], *Text*, ii, p. 66 with note 25 on p. 67. **I-III**, WRESZ., *Atlas*, iii, 87. Scribes in **II-III**, EKSCHEMITT, *Das Gedächtnis der Völker*, Abb. on p. 120; in **III**, BONNET, *Ägyptisches Schrifttum*, Abb. 12. Hyenas brought and fattened, KEIMER in *B.I.F.A.O.* lv (1955), pp. 13-19 [D] with figs. 7-12bis (from WRESZ., sketches by Wild); hyena fattened, id. in *Egypt Trav. Mag.* No. 22 (May 1956), fig. 7 on p. 10. Parts of **III**, **IV** and **V**, WEIGALL, *Anc. Eg. . . . Art*, 63, 64 [upper]. **III-V** and part of **VI**, LAUER, *Saqqara*, pls. 48-9. **IV-VI**, WRESZ., *Atlas*, iii, 73, 79. Netting fowl on left in **VI**, PRITCHARD, *Anc. Near East*, fig. 189.

(21) [1st ed. 31] Deceased leaning on staff, with [son] and wife, and registers, **I** (almost completely lost), man pushing canoe, **II** (much destroyed), men cutting out roes, **III**, netting fish and men fishing with baskets, with others in canoes, **IV**, scribes, squatting officials receiving fish, and men bringing fish.

VON BISSING, i, Taf. xvii-xxi. Upper part of deceased, GRDSELOFF in *Ann. Serv.* xlii (1943), fig. 22 (from VON BISSING), p. 118. Wife, STAEHELIN, *Tracht*, Taf. x [15]. Remains of **I**, WRESZ., *Atlas*, iii, 38A. **IV**, id. ib. 98B; four men with fish, *The Oriental Institute of the University of Chicago. The Handbook* (1931), fig. 8 on p. 10 (reversed); two men, WEIGALL, *Anc. Eg. . . . Art*, 64 [lower left].

(22) [1st ed. 33-4] Above doorway, deceased carried in palanquin, with attendants, men with [sunshades], and dwarf with monkey and dogs. Right of doorway, two registers of market scenes, with men bringing skins containing oil and filling oil-jar, and bringing staves and bartering.

VON BISSING, i, Taf. xxii, xxiii; WRESZ., *Atlas*, iii, 9, 117. Deceased in palanquin, LAUER, *Saqqara*, pl. 47. One dog, KEIMER in *B.I.F.A.O.* lv (1955), pp. 10-12 [B] with figs. 4 (from WRESZ.), 4 bis (sketch by Wild). Texts of upper register of market scenes, ČERNÝ Note-book, 118, p. 96 [top].

Room V. II of von Bissing.

(23) [1st ed. 35-6] Doorway. (a) and (b) Two registers with three offering-bringers in each.

VON BISSING, i, Taf. vii [1], xxiv.

(24), (26) and (27) Offering-bringers. Id. ib. ii, Taf. i [a], iv, vi.

(25) Deceased and offering-bringers. Id. ib. ii, Taf. ii, iii.

(28) Deceased, with offering-bringers before him, and behind (above doorway), offering-bringers, officials and scribes.

Id. ib. ii, Taf. v.

Room VI. III of von Bissing.

(29) [1st ed. 37-8] Doorway. (a) and (b) Two registers with three offering-bringers in each.

Id. ib. ii, Taf. vii.

(30) and (32) [1st ed. 39, 41] Registers (left end of (30) and right end of (32) erased), **I-II** (narrow), food-offerings, **III**, men carrying chests, **IV**, measurers and magazines, **V**, men dragging chests with feathers on top, **VI-VII** (narrow), bound animals.

(30) Id. ib. ii, Taf. xi-xiii. **III-IV**, WRESZ., *Atlas*, iii. 65. **VI-VII**, VON BISSING, *Denkmäler*, *Text* to Taf. 79, 80 [2nd fig.].

(32) VON BISSING, ii, Taf. viii [left], ix, xxx [a]. **III-IV**, WRESZ., *Atlas*, iii. 64 with Textabb. 64/65 on p. 128.

(31) [1st ed. 40] Deceased, and five registers of officials and sons behind.

VON BISSING, ii, Taf. x.

(33) (erased) [Deceased]. Id. ib. ii, Taf. viii [right].

Room VII. IV of von Bissing.

(34) [1st ed. 42-3] Doorway. (a) and (b) Two registers with three offering-bringers in each.

Id. ib. ii, Taf. xiv, xxxv [middle].

(35) [1st ed. 49] Registers, **I**, offerings, **II-III**, offering-bringers, **IV-V**, butchers.

Id. ib. ii, Taf. xxv, xxvi. Two short texts, ČERNÝ Notebook, 118, p. 96 [middle].

(36) Two registers of offering-bringers. VON BISSING, ii, Taf. xv.

(37) and (38) [1st ed. 44-5, 47-8] (partly above doorways) Deceased at table, with offering-list, offerings, priests, and offering-bringers.

(37) Id. ib. ii, Taf. xvi-xxiv, Beiblatt i [left]. Offering-list, HASSAN, *Giza*, vi [2], pls. lxxviii-lxxx [83], pp. 136-7. Four offering-bringers from bottom register, GUNN MSS. xviii. 5 [1] (photo.).

(38) VON BISSING, ii, Taf. i [b], xxvii-xxix, xxx [b]-xxxiii, Beiblatt i [right]. Five offering-bringers from bottom register, *The Toledo Museum of Art. Museum News*, No. 133 (March 1952), fig. on 2nd page (painting by J. L. Smith).

(39) [1st ed. 46] False-door (top missing).

VON BISSING, i, Taf. ii; ii, Taf. xxxiv. Name and titles, STEINDORFF in *A.Z.* xxxiii (1895), p. 71.

Room VIII. V of von Bissing.

(40) [1st ed. 50-1] (a) and (b) Two registers with three men bringing vessels in each. VON BISSING, ii, Taf. xxxv [left, right].

(41) (partly above doorway) and (43) Deceased, and registers of chests and vessels, with men bringing vessels with ointment and linen below.

(41) Id. ib. ii, Taf. xxxvii-xxxix. (43) Id. ib. ii, Taf. xli.

(42) and (44) Registers of chests and vessels, with men dragging vessels with ointment on sledges and carrying chests below.

(42) Id. ib. ii, Taf. xl. (44) Id. ib. ii, Taf. xxxvi.

Loose blocks.

Lintel-fragment with offering-text, in Berlin (East) Mus. 1124. L. D. ii. 116 [c], *Text*, i, pp. 159-60; text, *Aeg. Inschr.* i, pp. 26-7; see *Ausf. Verz.* p. 58.

Two registers, **I**, gathering figs, **II**, magazines. WRESZ., *Atlas*, iii. 62; id. *Bericht*, Taf. 76; **I**, FIRTH and GUNN, ii, pl. 8; i, pp. 21, 116 [1]; text of **II**, i, p. 117 [9].

Various. Texts, id. ib. i, pp. 116-17 [2-8].

Burial chamber. Plan and section, id. ib. i, fig. 15, pp. 21-3.

Walls. Offerings, magazines and offering-texts. North and south, id. ib. ii, pl. 5 [A, B]; texts of all, i, pp. 117-21.

Sarcophagus recess. Walls with vessels, texts and offering-list. Texts, id. ib. i, pp. 121-5; offering-list, HASSAN, *Giza*, vi [2], pls. lxxiii-lxxx [84], pp. 136-7.

Sarcophagus. FIRTH and GUNN, ii, pl. 5 [C]; texts, pl. 60 [1, 2]; i, pp. 125-6.

Canopic-jars, alabaster, in Cairo Mus. JE 47031 bis, 47032 bis, 47785-6. Id. ib. ii, pls. 12 [A, B], 65 [5-8]; i, pp. 22 [iv], 126.

Vase, alabaster, in Cairo Mus. JE 47050. Id. ib. ii, pl. 15 [A, 7]; i, pp. 22 [ii], 126.



Offering-stand, copper. Id. ib. ii, pl. 65 [9]; i, p. 23 [viii].

Necklace-fragment and clasp, former from sarcophagus, gold, in Cairo Mus. CG 53839, 53834. Id. ib. ii, pl. 15 [C]; i, pp. 23 [v, vi], 126; see VERNIER, *Bijoux et orfèvreries (Cat. Caire)*, i, pp. 514-15, 512-13.





Various finds

Statue, wood, in Cairo Mus. JE 20830.

Offering-table, perhaps from here, in Cairo Mus. CG 1368. Text, BORCHARDT, *Denkmäler*, i, p. 31.

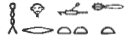
MERERUKA  MERI , Chief Justice and Vizier, Inspector of prophets and tenants of the Pyramid of Teti, etc. Temp. Teti.

Map LII. Plan LVI.

Wife, Wattetkhet-hor  Seshseshet , King's eldest daughter of his body, etc. Mother, Nezetempet  Tit , Royal acquaintance.

Description, texts, and plan, DARESSY, *Le Mastaba de Mera* in *Mémoires présentés à l'Institut Égyptien* [etc.], iii (hereafter DARESSY), pp. 521-74, plan facing p. 520. Description with plan, id. in *Rev. Arch.* 3 Sér. xxix (1896), pp. 319-28 with fig. 1, cf. fig. 2. Plan, FIRTH and GUNN, *Teti Pyr. Cem.* ii, on pl. 51; DUELL, *The Mastaba of Mereruka*, i, plan facing pl. 2; ii, plan before pl. 105. Titles, FIRTH and GUNN, op. cit. i, pp. 131-6. Views, DUELL, i, pls. 2, 3; SAAD in *Ann. Serv.* xliii (1943), pl. xxxiii, p. 449. See NIMS in *J.A.O.S.* 58 (1938), pp. 638-47.

Enclosure wall.

(1)–(2), (3)–(4) [1st ed. 1–2] Figures of deceased and titles.

DUELL, i, pl. 4 [A]; ii, pls. 217–19 [A]. (3)–(4) FIRTH and GUNN, op. cit. ii, pl. 9 [A], cf. i, p. 26 [bottom]; block at east end, BINDER-HAGELSTANGE, *Ägypten. Ein Reiseführer* (1966), fig. on p. 346 [left]. Texts, FIRTH and GUNN, op. cit. i, pp. 137–9 (including some from east face).

Exterior. One fragment, in Cairo Mus. JE 44932.

(5)–(9) Remains of (5) (a), (b), (c), name and titles, (6) and (7) [1st ed. 3, 4] deceased standing, and seated, (8) text and deceased seated, (9) deceased.

(5) SAAD, op. cit. pl. xxxvi [right], pp. 451–2. (6) and (7) DUELL, ii, pls. 216 [A], 214 [B]; texts, FIRTH and GUNN, op. cit. i, p. 139 [3, 1]. (8) DUELL, ii, pl. 215; text, FIRTH and GUNN, op. cit. i, p. 139 [2]. (9) DUELL, ii, pl. 216 [B].

A. MERERUKA.

Chapel. DUELL, i, ii, passim.

Doorway.

(10) (a) Lower part of deceased. (b)–(c) [part, 1st ed. 5] Lintel, remains of double-scene with deceased and text. Drum with remains of titles. Jambs, deceased with small figure of wife, titles, and remains of address left of (b). (d) and (e) Deceased in long kilt. (f) [1st ed. 6] Deceased painting seasons, and son Khenu  before him.

[DARESSY, 523–5] (a)–(c) DUELL, i, pl. 4 [B]; ii, pl. 212 [A]. (a) Id. ib. ii, pl. 214 [A]. (b)–(c) Drum, id. ib. ii, pl. 213 [A]. Address, id. ib. pl. 213 [B]; text, SETHE, *Urk.* i. 87–8 [8, A]; EDEL in *Mitt. Kairo*, 13 (1944), pp. 59–61, cf. 56–66. (d) and (e) DUELL, ii, pl. 212 [B, C]. (f) Id. ib. i, pls. 6, 7; id. in *Technical Studies in the Field of the Fine Arts*, viii (1939–40), figs. 1, 2, pp. 175–91; SPIEGELBERG, *Geschichte*, Abb. 23; ERMAN in *Ä.Z.* xxxviii (1900), fig. on p. 107; WRESZ., *Atlas*, iii. 1; LANSING in *M.M.A. Bull.* n.s. iii (April 1945), fig. on p. 203, cf. p. 201; BLACKMAN and APTED, *The Rock Tombs of Meir*, vi, fig. 1 on p. 31; FORBES, *Studies in Ancient Technology*, iii, fig. 45; LAUER, *Saqqara*, pl. 30; Khenu, FIRTH and GUNN, op. cit. ii, pl. 17 [D]; i, pp. 27, 38.

Room I. Views, DUELL, i, pl. 5.

(11) (upper part lost) Deceased with wife and son Meryteti, and registers of *ka*-servants and attendants before and behind them.

[DARESSY, 527] DUELL, i, pl. 8.

(12) [1st ed. 7–8] Deceased (middle part lost) with wife in canoe fowling, with attendants behind and men in canoe before them, and fish, crocodiles and hippopotami at bottom.¹

[DARESSY, 525] DUELL, i, pls. 15–19; DE MORGAN, *Recherches*, i, fig. 508; WRESZ., *Atlas*, iii. 106 [A], 107, 105 [D]. Men in canoe, mainly with scene with ichneumon, WEIGALL, *Anc. Eg. . . . Art*, 62; FECHHEIMER, *Plastik* (1914), pl. 123; (1923), pl. 133 (as Ty); CAPART, *Memphis*, fig. 382; id. *Paysage*, fig. 12; ERMAN, *L'Égypte des pharaons*, pl. ix; RANKE, *Meisterwerke*, Abb. 24–5; id. *The Art of Ancient Egypt*, and BREASTED, *Geschichte Ägyptens* (1936), 187–8 (as Ty); *The Oriental Institute of the University of Chicago. The Handbook* (1935), fig. 6; LANGE, *Ägypten. Landschaft*, pl. 46; id. and HIRMER, *Ägypten. Architektur*, pl. 76; FETT *Mumier og sfinks*, pl. on p. 47 (as Ty); METZGER in *The Biblical*

¹ Selected references.

Archaeologist, x (1947), fig. 1 on p. 25; LAURENT-TÄCKHOLM, *Faraos blomster*, pl. on pp. 20-1; CHAMPDOR, *L'Égypte des Pharaons*, pl. on pp. 20-1; WOLDERING, *Götter*, fig. on p. 230 [Kat. 48]; GIEDION, *The Eternal Present*, ii, fig. 303; PANOFKY, *Tomb Sculpture*, fig. 12; ANGIOLETTI and BIGONGIARI, *Testimone*, Tav. 20-1; MÜLLER, *Äg. Kunst*, Abb. on p. 43 [upper]; three men, PIJOÁN, *Summa Artis*, iii (1945), fig. 10. Ichneumon, id. ib. fig. 11; HAMANN, *Tierplastik im Wandel der Zeiten*, Taf. 8 (as Ty); id. *Äg. Kunst*, Abb. 154; LANGE, *Ägyptische Tierplastik*, Abb. 7; id. *Lebensbilder*, Abb. 15; KEIMER, *Études d'Égyptologie*, iv (1942), fig. 3, p. 8; BYVANCK, *De Kunst*, pl. xxiv [87] (as Ty); WOOD and DROWER, *Egypt in Colour*, pl. 8. Frog and grasshoppers on reeds below canoe of deceased, KEIMER in *R.E.A.* ii (1929), fig. 1, p. 211; SPIEGEL, *Hochkultur*, Taf. 62 [b]; ANGIOLETTI and BIGONGIARI, op. cit. Tav. 22. Text of wife, ERMAN, *Reden, Rufe und Lieder*, p. 38 [5].

(13) [1st ed. 9] Registers, I (left end only), men in canoe, II (left half only), men bringing birds in cages, III, gardening, IV, four groups of men overthrowing bulls, V, herdsmen in canoes and cattle crossing canal, with crocodile.

DUELL, i, pls. 20-1; WRESZ., *Atlas*, iii. 59. II-V, TARCHI, *L'Architettura*, Tav. 10 (as Ty); GARDINER MSS. photo. 28.1088. II-III, MONTET, *Scènes*, pl. ix [3] facing p. 112. Left part of III-V, WOLF, *Ägypten* in KINDERMANN, *Handbuch der Kulturgeschichte*, 1st ed., Abb. 240; LAUER, *Saqqara*, pl. 32. Men watering garden in III, MAZAR, *Views*, ii, pl. 246. IV, two groups on left, MURRAY, *Sculpture*, pl. xiii [2]; 3rd group from left, WEIGALL, *Anc. Eg. . . . Art*, 61 [upper right]; group on right, PETRIE, *Arts and Crafts*, fig. 56 facing p. 51 (as Ty); SÄVE-SÖDERBERGH, *Egyptisk Egenart*, fig. 31; WOLDERING, *Götter*, Abb. 34; COTTRELL, *Egypt*, fig. 34. Right ends of IV and V, BAIKIE, *Eg. Antiq.* pl. v [lower] (as 'Ankhmachor). Texts of V, [DARESSY, 526]; cf. ERMAN, *Reden, Rufe und Lieder*, p. 30 [3, 7].

(14) Right of doorway, deceased and wife (heads lost), above and left of doorway, men carrying empty palanquin, officials and attendants.

[DARESSY, 526] DUELL, i, pl. 14.



(15) [1st ed. 10-11] (upper part lost) Deceased with wife in canoe spearing fish, attendants behind, and registers with men in canoes, bringing fish and two groups of men in canoes harpooning hippopotami before them, with fish and crocodile.

[DARESSY, 526-7] DUELL, i, pls. 9-13; WRESZ., *Atlas*, iii. 105 [A]. Fish, and birds and ichneumons, GAILLARD, *Recherches sur les poissons* [etc.], pl. iv, fig. 5; fishes, figs. 23, 29. Registers before deceased, MONTET, *Scènes*, pl. ii facing p. 24, cf. p. 22 [1]. Left group of men harpooning hippopotami, WEIGALL, *Anc. Eg. . . . Art*, 61 [lower]; with fish left of it, WILLIAMS in *A. J. A.* xl (1936), fig. 7 on p. 555; incomplete, TOUNY and WENIG, *Sport*, Taf. 56. Some men harpooning and hippopotami, BRUNNER-TRAUT, *Die Alten Ägypter*, Taf. 11a; hippopotami, LANGE, *Äg. Kunst*, pl. 35; id. *Lebensbilder*, Abb. 11; id. and HIRMER, *Aegypten. Architektur*, pl. 77; DONADONI in *Enciclopedia dell'Arte Antica Classica e Orientale*, iv, fig. 1105 on p. 927; *Capolavori*, i, No. 10 (1963), fig. on p. 163 [lower left]; ABBATE, *Arte egizia*, fig. 26 on p. 50 [upper]; WOLF, *Kunst*, Abb. 209; id. *Hochkulturen*, Abb. 69; GROENEWEGEN-FRANKFORT and ASHMOLE, *Art of the Ancient World*, fig. 40; one, LANGE, *Ägyptische Tierplastik*, Abb. 5.

Room III. Views, DUELL, i, pl. 22.

(16) Doorway. (a) Remains of three registers of offering-bringers; (b) four registers of offering-bringers.

(a) DUELL, ii, pl. 189 [A]. (b) Id. ib. ii, pl. 190.

(17) (upper part lost) Deceased and wife, with *ka*-servants before them, and brother Ihy  and son Memi  behind.

[DARESSY, 528] DUELL, i, pl. 23 [A]. *Ka*-servant with calf, WEIGALL, *Anc. Eg. . . . Art*, 61 [upper left]; another with crane, DE MORGAN, *Recherches*, i, fig. 524.

(18) [1st ed. 12-13] (upper part lost) Deceased and wife with attendants, and two remaining registers of hunting.

DUELL, i, pls. 23 [B], 24-5. Hunting, DE MORGAN, *op. cit.* i, fig. 514; WRESZ., *Atlas*, iii. 100; LAUER, *Saqqara*, pl. 33. Antelope, and dog dispatching ibex, in bottom register on right, MICHALOWSKI, *Art*, fig. 247.

(19) (upper part lost) Deceased and wife with son Meryteti, and female attendants behind.

[DARESSY, 528] DUELL, i, pl. 23 [C].

(20) [1st ed. 14-15] Deceased (head lost) and wife followed by six registers of *ka*-servants, and registers of industries before them (with exception of IV right parts of all lost), I (upper part lost), sculptors, II, vase-makers and men bending poles, III, carpenters, IV, men dragging shrines with statues, V, metal-workers, VI, jewellers, some of them dwarfs.

[DARESSY, 528-30] DUELL, i, pls. 26-33. Wife, *The Oriental Institute of the University of Chicago. The Handbook* (1935), fig. 7; LANGE and HIRMER, *Aegypten. Architektur*, pl. 74; upper part, LANGE, *Lebensbilder*, Abb. 2; id. *Ägypten. Landschaft*, pl. 41. I-VI, WRESZ., *Atlas*, iii. 33. II, vase-makers, DE MORGAN, *Recherches*, i, fig. 497; man scraping bark, MONTET, *Scènes*, fig. 42 on p. 313. III, polishing bed and making doorway, JÉQUIER, *Hist. civ.* fig. 146; polishing bed, id. *Les Frises d'objets des sarcophages du Moyen Empire*, fig. 752. Middle part of IV-VI, CHAMPDOR, *L'Égypte des Pharaons*, pl. on p. 19 (as Ty); *The Egyptian Education Bureau London. The Bulletin*, No. 58 (Sept. 1951), fig. on p. 16 [upper left]. V-VI, DE MORGAN, *op. cit.* i, fig. 527; SAMEH, *Daily Life*, figs. on pp. 100-1; MAZAR, *Views*, i, pl. 175; left part, PRITCHARD, *Anc. Near East*, fig. 133. V, weighing, TZARA and SVED, *L'Égypte face à face*, pl. on p. 72 (reversed); men with blowpipes, BRUYÈRE, *Rapport sur les fouilles de Deir el Médineh (1934-1935)*, Pt. 3, fig. 106. Dwarfs in VI, BAKER, *Furniture*, fig. 54. Some texts, ERMAN, *Reden, Rufe und Lieder*, pp. 40 [5], 41 [1], 43 [6], 44 [6], 45 [3, 4].

Room IV. Views, DUELL, i, pl. 34.

(21) Doorway. (a) Remains of two registers of offering-bringers; (b) three registers of offering-bringers.

[DARESSY, 530] (a) DUELL, ii, pl. 189 [B]. (b) Id. ib. ii, pl. 191.

(22) Deceased and wife (middle part missing). [DARESSY, 530] DUELL, i, pl. 35.

(23) [1st ed. 16] Remains of three registers (upper two almost completely lost), chiefs of estates rendering accounts, with scribes, and man beaten at whipping-post.

[DARESSY, 531] DUELL, i, pls. 36-8; LAUER, *Saqqara*, pl. 35. II-III, WRESZ., *Atlas*, iii. 68 [A]; left half, PIRENNE, *Hist. civ.* i, pl. 94 [upper] facing p. 297. III, CAPART, *Memphis*, figs. 225, 227; scribes and chiefs on left, HAMANN, *Äg. Kunst*, Abb. 148; RANKE, *Meisterwerke*, Abb. 23b; PRITCHARD, *Anc. Near East*, fig. 231; DIRINGER and REGENSBURGER, *The Alphabet* (1968), ii, fig. 2.2b on p. 38; HUSSEIN, *Vom Papyrus zum Codex*, pl. on p. 37 [upper]; scribes, CHAMPDOR, *L'Égypte des Pharaons*, pl. on p. 16; KUSCH, *Ägypten im Bild*, Abb. 62 [lower] (as Ptahhotp); group of chiefs on left, WOLDERING, *Götter*, Abb. 35; man beaten, CAPART in *Ä.Z.* xxxvi (1898), fig. on p. 126 (reversed). Some texts, ERMAN, *Reden, Rufe und Lieder*, p. 52 [top].

(24) (upper part lost) Deceased and wife, with offering-bringers before statues in shrines.

[DARESSY, 531] DUELL, i, pl. 39.

(25) Lower part of deceased and wife. Id. ib. i, pl. 40 [A].

(26) [1st ed. 17] (upper part lost) Deceased and wife followed by attendants and scribes,

and registers, I-II (almost completely lost), bringing fowl and fish, III, fishing from canoes with small nets and baskets and angling, with brother Ihy drinking and eating, IV, netting fish.

[DARESSY, 532-3] DUELL, i, pls. 41-5. III-IV, DE MORGAN, *Recherches*, i, fig. 518; GAILLARD, *Recherches sur les poissons* [etc.], fig. 4, with fishes on figs. 15, 21; WRESZ., *Atlas*, iii. 96; right end, *Capolavori*, i, No. 10 (1963), fig. on p. 163 [lower right]; Eng. ed. fig. on p. 155 [lower right]. Canoe with Ihy in III, DAUMAS in *B.I.F.A.O.* lxii (1964), figs. 6, 7, pp. 72-3, 74; GHALIOUNGUI, *Magic and Medical Science* (1963), pl. iv.

(27) (top part lost) Deceased with wife and son Meryteti, preceded by registers of attendants, including one with monkey and two dogs.

[DARESSY, 532] DUELL, i, pl. 46; WRESZ., *Atlas*, iii. 12.

(28) Lower part of deceased and wife. DUELL, i, pl. 40 [B].

Room V.

(29) Jamb of doorway with three registers of offering-bringers (top incomplete).

Id. ib. ii, pl. 192 [A].

Room VI. Views, id. ib. i, pl. 47.

(30) Doorway. (a) Remains of three registers of offering-bringers; (b) of two registers of offering-bringers.

DUELL, ii, pl. 193.

(31) (upper part lost) Deceased and wife, and remains of three registers with scribes and men bringing animals.

[DARESSY, 533] DUELL, i, pls. 48 [B], 50-1; WRESZ., *Atlas*, iii. 91 [A-C].

(32) (upper part lost) Deceased and wife, and two remaining registers of estates.

[DARESSY, 533-4] DUELL, i, pls. 48 [A], 49. Estates Nos. 11-15 (of JACQUET-GORDON) in bottom register, TZARA and SVED, *L'Égypte face à face*, pl. on p. 44. Names of estates, JACQUET-GORDON, *Domaines*, pp. 411-13 [35S6], cf. figs. 171-2.

(33) [1st ed. 18] (upper part lost) Remains of four registers of poultry-yard scenes.

[DARESSY, 534] DUELL, i, pls. 52, 53 [B]. Part of II and III-IV, WRESZ., *Atlas*, iii. 78 [A]. Feeding cranes in IV, SCHÜZ, *Über Stelzvögel* [etc.] in *Die Vogelwarte*, 23 (1966), Abb. 9, 10 on p. 271.

(34) Remains of food offerings. DUELL, i, pl. 53 [A].

(35) [1st ed. 19] Two remaining registers, offering-bringers and butchers.

[DARESSY, 534] DUELL, i, pl. 54. Butchers, WRESZ., *Atlas*, iii. 94 [A]; group on right, MONTET, *Scènes*, fig. 28 on p. 163; SOGA, *The Nile*, fig. on p. 70.

(36) (upper part lost) Deceased with wife and son Meryteti, and two remaining registers, legs of men bringing fish, and netting fish.

DUELL, ii, pls. 48 [C], 55. Netting fish, WRESZ., *Atlas*, iii. 98 [A].

(37) (upper part lost) Deceased and wife. DUELL, i, pl. 48 [D].

Room VIII. Views, id. ib. i, pl. 56.

(38) Doorway. (a) and (b) Remains of two registers of offering-bringers.

Id. ib. ii, pl. 194.

(39) Remains of scene with butchers. Id. ib. i, pl. 61 [B].

(40) and (41) (upper parts lost) Deceased seated, with wife squatting by his legs, offering-list (lost at (40)), and offerings, priests and offering-bringers.

[DARESSY, 535-6] (40) DUELL, i, pls. 57-60, 61 [C]; two men bringing fowl in bottom

register, MICHALOWSKI, *Art*, fig. 253; offerings brought by three offering-bringers (Nos. 16-18 of DUELL) in bottom register, SAMEH, *Daily Life*, fig. on p. 62 [lower]. (41) DUELL, i, pls. 63-7 (with fragment lying on floor), 61 [A] (now affixed at (40)); deceased and wife, BAKER, *Furniture*, fig. 52.

(42) False-door (top missing), with ointment-vessels on each side.

[DARESSY, 536-7] DUELL, i, pl. 62.

Room IX. Views, DUELL, i, pl. 68.

(43) Doorway. (a) and (b) Remains of two registers of men bringing jars of oil.

[DARESSY, 538] DUELL, ii, pl. 195.

(44) Three remaining registers, men bringing chests of jewelry, dragging oil-jars on sledge and bringing chests with clothing.

[DARESSY, 538] DUELL, i, pl. 69.

(45) and (46) (upper parts lost) Deceased and wife, followed by men bringing chests with clothing and dragging oil-jars on sledge, with men bringing jewelry, chests with clothing, linen and jars of oil.

(45) *Id. ib.* i, pls. 70, 71 [A], 72, 73 [A]. (46) [DARESSY, 538-9] DUELL, i, pls. 71 [B], 74-6.

(47) Remains of scene with offering-bringers before deceased and wife.

Id. ib. i, pl. 73 [B].

Room X. Views, *id. ib.* i, pl. 77.

(48) (top lost) Deceased seated with wife squatting, and five registers of attendants behind and offering-bringers before them.

[DARESSY, 540] DUELL, i, pls. 78-82.

(49) (top lost) Deceased seated with wife squatting, with registers of attendants behind and men with jars, jar-stands, linen and chests with clothing before them.

[DARESSY, 542-3] DUELL, i, pls. 96, 97 [B], 98-9.

(50) [1st ed. 20] Wife playing harp to deceased on couch, with jars of oil and chests with jewelry and clothes below, and female and male attendants on each side.

[DARESSY, 542] DUELL, i, pls. 94-5; WRZESZ., *Atlas*, iii. 5. Incomplete, LAUER, *Saqqara*, pl. 36. Deceased and wife, HICKMANN, *45 Siècles*, pl. xix; *id. Égypten*, Abb. 35; *id. in Cahiers d'Hist. Ég. Sér. vi* [5, 6] (1954), fig. 18, pp. 294-5; with jars and chests, CAPART, *Rue de Tombeaux*, pl. civ; *id. Memphis*, fig. 354; BAKER, *Furniture*, pl. iii facing p. 32, fig. 53.

(51) (upper part lost) Deceased and wife, with registers of attendants behind and servants preparing bed and officials before them.

[DARESSY, 542] DUELL, i, pls. 91-3. Servants preparing bed and officials, WRZESZ., *Atlas*, iii. 4.

(52) Deceased seated with wife squatting, five registers of offerings, vases, and offering-bringers before them, and brothers and sons Memi, Meryteti and Khenti behind them.

[DARESSY, 541-2] DUELL, i, pls. 88-90.

(53) [1st ed. 21] (top part lost) Deceased and wife, with registers of *ka*-servants behind, preceded by registers, I-III, *ka*-servants with sceptres, IV, female clappers and dancers, V, male clappers and dancers in pairs.

[DARESSY, 540-1] DUELL, i, pls. 83-7. Right part of III-V, PRITCHARD, *Anc. Near East*, fig. 210. IV-V, WRZESZ., *Atlas*, iii. 28. Clappers and dancers in IV-V, FAVRE, *L'Arte*, fig. on p. 75. Two clappers and four dancers in IV, VON BISSING in *Ä.Z.* xxxvii (1899), fig. on p. 76 [lower]. Dancers in V, HICKMANN in *Bull. Inst. Ég.* xxxvii [1] (1954-5), figs.

8, 10, 12, 14, 15, pp. 172-83; id. *Musicologie pharaonique*, figs. 8, 10, 12, 14, 15, pp. 134-45; five dancers on right, TOUNY and WENIG, *Sport*, Taf. 66-7; text of dancers, ERMAN, *Reden, Rufe und Lieder*, p. 60 [4].

(54) (bottom part only) Remains of offering-bringers before statue of deceased.

DUELL, i, pl. 97 [A].

Pillars.

(55) and (56) All faces, name and titles with deceased at bottom. Id. ib. i, pls. 100-103.

Room XI. Views, id. ib. ii, pl. 105.

(57) Jamb of doorway with remains of two registers of offering-bringers.

Id. ib. ii, pl. 192 [B].

(58) and (59) At bottom, offering-bringers.

(58) [DARESSY, 544, as north wall] DUELL, ii, pl. 106 [A]. (59) Id. ib. ii, pl. 106 [B].

Two (2nd and 3rd from right), DE MORGAN, *Recherches*, i, fig. 523.

(60) (upper part lost) Deceased and wife. DUELL, ii, pl. 108.

(61) False-door. [DARESSY, 543] DUELL, ii, pl. 107.

(62) [1st ed. 22] Two remaining bottom registers of butchers.

[DARESSY, 543-4] DUELL, ii, pls. 109 [A], 110. Part of text, ERMAN, *Reden, Rufe und Lieder*, p. 8 [4].

(63) Two remaining bottom registers with an offering-bringer in each.

DUELL, ii, pl. 109 [B].

Room XII. Views, id. ib. ii, pl. 111.

(64) Doorway. (a) and (b) Two registers of offering-bringers.

[DARESSY, 544] DUELL, ii, pl. 196.

(65) (upper part lost) Deceased and wife, with men carrying chest below.

Id. ib. ii, pl. 112.

(66) [1st ed. 23] Deceased seated with wife squatting by his legs, and registers, **I-III**, offerings, **IV**, slaughtered animals, **V**, men dragging sledges with produce, **VI**, offering-bringers, scribe and men measuring fruit, **VII**, magazines, **VIII** (under whole scene), vintage scenes.

[DARESSY, 544-5] DUELL, ii, pls. 113-16. Deceased with wife and **V-VIII**, WRESZ., *Atlas*, iii. 63. **VI-VIII**, PRITCHARD, *Anc. Near East*, figs. 90, 155; omitting wine-press, MAZAR, *Views*, iv, pl. 70. Text of scribe in **VI**, ERMAN, *Reden, Rufe und Lieder*, p. 46 [3]; ČERNÝ Notebook, 118, p. 95 verso [middle]. Men marking rhythm and wine-press in **VIII**, MONTET in *Rec. Trav.* xxxv (1913), figs. 2, 5 on pp. 119, 121; men marking rhythm, HICKMANN, *Ägypten*, Abb. 47.

(67) Deceased seated with wife squatting, with offerings, offering-bringers, and slaughtered animals presented by two lector-priests.

[DARESSY, 545] DUELL, ii, pls. 120-2.

(68) Deceased seated smelling unguent-jar, and men bringing linen and jars of oil, with slaughtered animals below.

[DARESSY, 546] DUELL, ii, pls. 117-19.

Room XIII. Views, id. ib. ii, pls. 124-6; JÉQUIER, *L'Architecture*, i, pl. 5 [3, 4].

(69) Doorway. (a) Remains of offering-bringers at bottom. (b) Remains of two registers of offering-bringers.

DUELL, ii, pl. 197.

(70) [1st ed. 24-5] Bottom register, female mourners, coffin carried and transported in boat towed by three rowing-boats, with swimmers in water, purification-tent (*ibw*), and coffin carried, with female clappers and dancers, offerings and lector-priest before tomb.

At top, isolated blocks with remains of titles and scenes with boats, affixed here but at least some of them from west wall, (72).

Bottom register. [DARESSY, 546] DUELL, ii, pls. 130-1. Mourners, CAPART, *Memphis*, fig. 391; WERBROUCK in *Chron. d'Ég.* iii (1927-8), pp. 48-51 with fig.; id. *Pleureuses*, pl. i [upper], p. 16; SCHÄFER in *Ä.Z.* 73 (1937), Abb. 1, cf. 3, 5, pp. 102-6; LÜDDECKENS in *Mitt. Kairo*, 11 (1943), Abb. 8, cf. 7, pp. 18-19; PIRENNE, *Hist. civ.* i, pl. 92 [lower] facing p. 293; group on right, TZARA and SVED, *L'Égypte face à face*, pl. on p. 34. Swimmers, CAPART, *Memphis*, fig. 390; id. *Documents*, i, pl. 73 [B]. Purification-tent, GRDSELOFF, *Das ägyptische Reimigungszelt*, Abb. 1, p. 10; HASSAN, *Giza*, iv, fig. 35 (both probably from DUELL); with part of scene before tomb, LÜDDECKENS, op. cit. Abb. 5, 6 (from DUELL), p. 6.

Blocks at top, DUELL, ii, pls. 132-7. Text of two blocks, SETHE, *Urk.* i. 88 [8, B].

(71) (upper part lost) Deceased with two sons (?). DUELL, ii, pl. 138.

(72) [1st ed. 26-7] (upper part lost) Deceased seated, with wife squatting, attendants below, and remains of two registers, one rowing-boat (rest destroyed), five sailing-boats, and sub-register with three sailors.

[DARESSY, 547] DUELL, ii, pls. 139-45. Boats and sailors, WRESZ., *Atlas*, iii. 114 [A, B], 115 [A]. 1st sailing-boat and part of 2nd, LAUER, *Saqqara*, pl. 38. Text above 4th sailing-boat, ERMAN, *Reden, Rufe und Lieder*, p. 54 [7]. Blocks, probably from here, now affixed at south wall, see above, (70).

(73) (above doorway) [Deceased seated, with wife squatting], and man leading two dogs below.

DUELL, ii, pl. 146.

(74) [1st ed. 28] (upper part lost) Deceased carried in palanquin preceded and followed by attendants, with two dwarfs with monkey and dogs, and register of brothers and sons (including Nüfer) below.

[DARESSY, 548] DUELL, ii, pls. 157-8; WRESZ., *Atlas*, iii. 8. Dog, SAMEH, *Daily Life*, fig. on p. 29 [lower].

(75) Deceased led by son Memi (name replaced by [Pepy]ankh, perhaps another name of Memi) and 'Aperef  (probably also son).

[DARESSY, 548] DUELL, ii, pls. 104 (frontispiece), 154-6; WRESZ., *Atlas*, iii. 7; SMITH, *Hist. Eg. Sculp.* pl. 56 [a], p. 208; id. *Art . . . Anc. Eg.* pl. 51 [B], p. 76; GALASSI in *Critica d'Arte*, n.s. ii (1955), fig. 264, p. 315; GROENEWEGEN-FRANKFORT, *Arrest and Movement*, pl. xxiii [A] facing p. 61; DRIOTON and DU BOURGUET, *Pharaons*, pl. 17; LAUER, *Saqqara*, pl. 41.

(76) [1st ed. 29-30] On right, deceased with wife and mother, and six registers, I, building boats, II-VI, feeding and bringing animals (including fattening hyenas in VI).

[DARESSY, 548-9] DUELL, ii, pls. 149-53; VON BISSING, *Äg. Kunstgeschichte*, Taf. lxxi [418], *Text*, i, pp. 96, 98; WRESZ., *Atlas*, iii. 19 [left], 37. Upper part of deceased and I-III, VON BISSING in OTTO, *Handbuch der Archäologie*, i, Taf. 16 [4]. II-VI, DE MORGAN, *Recherches*, i, figs. 509, 521, 513; GAILLARD, *Les tâtonnements des Égyptiens* [etc.] in *La Revue d'Ethnographie et de Sociologie* (1912), pl. xi, figs. 3, 5, 8-11, 14, 16. VI, two men with hyena on right, MICHALOWSKI, *Art*, fig. 243; feeding 2nd hyena from right, BOULANGER, *Ägyptische und Altorientalische Malerei*, pl. on p. 38 [upper].

(77) [1st ed. 31] Niche with statue of deceased, and offering-table.

[DARESSY, 550] Views of niche, mostly showing parts of adjoining scenes, pillars and offering-table, DUELL, i, pl. 1 (frontispiece); ii, pls. 123, 147-8; DARESSY in *Rev. Arch.* 3 Sér. xxix (1896), pl. xviii, p. 325; CAPART, *Rue de Tombeaux*, pl. cvii; id. *L'Art ég.* (1909), pl. 26; id. *L'Art ég.* i, pl. 52; id. *Memphis*, fig. 317; BOREUX, *L'Art ég.* pl. xxi; MASPERO, *Hist. anc.* i, fig. on p. 253; id. *Guide* (1914), fig. 1 on p. 13; (1915), fig. 4 on p. 16; id. *L'Égypte*, fig. 60; FECHHEIMER, *Plastik*, Taf. 13; WARD (J.), *Pyramids and Progress*, fig. on p. 50 [upper]; SPIEGELBERG, *Geschichte*, Abb. 27; VON BISSING, *Äg. Kunstgeschichte*, Taf. lxx [415], *Text*, i, p. 69; ii, pp. 50, 155; WRESZ., *Atlas*, iii. 20; LANGE, *Äg. Kunst*, pl. 22; GALASSI, *Tehenu*, fig. 100; BADAWY, *A History of Egyptian Architecture*, i, pl. viii [a]; FRANKFORT, *Ancient Egyptian Religion*, pl. 22; WOOD and DROWER, *Egypt in Colour*, pl. 9; LAGIER, *L'Égypte monumentale et pittoresque*, pl. 10; ALDRED, *Egypt*, fig. 117; BUSCHOR, *Bildnisstufen*, Abb. 117; DE CENIVAL, *Living Architecture: Egyptian*, pl. 42; SOGA, *The Nile*, fig. on p. 52 [lower]; VIOLLET and DORESSE, *Egypt*, pl. 58; KUSCH, *Ägypten im Bild*, Abb. 61; LAMBRINO, *L'Égypte*, fig. on p. 40; POCHAN, *L'Énigme de la Grande Pyramide*, 4th pl. after p. 96; MICHAŁOWSKI, *Piramidy i mastaby*, pl. 22. Texts of offering-table, DUELL, ii, pl. 198.

(78) [1st ed. 32-3] (partly above and either side of doorway) Deceased with wife and mother, and registers, **I-II** (right part lost), boys bringing birds, catching birds, fig-harvest, **III-IV**, boys' games, **V**, girls' game and mirror dance, **VI**, boys, **VII**, attendants.

[DARESSY, 550-1] DUELL, ii, pls. 159-65. Almost complete, *Great Museums*, pl. 147 [left]; MÜLLER (H. W.) in *Encyclopedia of World Art*, iv, pl. 336. Omitting **I-II**, DE CENIVAL, *Living Architecture: Egyptian*, pl. 41. Omitting **VII**, WRESZ., *Atlas*, iii. 19 [right], 22. One trap with bird in **II**, GAILLARD in *Kémi*, ii (1929), fig. 9 on p. 36; GRDSELOFF in *Ä.Z.* 74 (1938), Abb. 1 on p. 137. **III-IV**, TOUNY and WENIG, *Sport*, Taf. 30. **III-V**, PRITCHARD, *Anc. Near East*, figs. 216-17; almost complete, SAMEH, *Daily Life*, figs. on pp. 113, 115 [right]. Deceased with wife and mother, and **III-VII**, CAPART, *Memphis*, figs. 304 [left], 306. **III-VII**, PIRENNE, *Hist. civ.* i, pl. 89 facing p. 292; LAUER, *Saqqara*, pl. 37. High jump in **III**, SAAD in *Ann. Serv.* xxxvii (1937), pl. i [A], p. 214; EATON in *Boston Mus. Bull.* xxxv (1937), fig. on p. 55 [lower]. Boys in middle of **III**, and girls' game in **V**, DIEM, *Körperkultur im alten Ägypten in Olympische Rundschau* (1938), figs. 28, 16, pp. 11, 10. **IV-V**, HICKMANN, *Ägypten*, Abb. 29. **IV-VI**, id. in *Egypt Trav. Mag.* No. 30 (Feb. 1957), fig. 3 on p. 8; id. in *Bull. Inst. Ég.* xxxvii [1] (1954-5), pl. i, pp. 155-6. Four girls in mirror-dance in **V**, id. ib. fig. 2, p. 155; id. *Musicologie pharaonique*, fig. 2, p. 117 (both from DUELL); text above, ČERNÝ Notebook, 118, p. 95 verso [bottom]. Some texts from **III-V**, ERMAN, *Reden, Rufe und Lieder*, pp. 59 [3-5], 60 [1, 2], 61 [1].

(79) [1st ed. 34] (upper part lost) Deceased and wife seated playing draughts with a son(?), and offering-bringers and attendants.

DUELL, ii, pls. 171-2; WRESZ., *Atlas*, iii. 6; LAUER, *Saqqara*, pl. 40. Omitting register below, PILLET in *R.E.A.* i (1927), fig. 3 on p. 161; CAPART, *Memphis*, fig. 12. Son at draughts-board, BAKER, *Furniture*, fig. 58 on p. 58.

(80) [1st ed. 35-6] (upper part lost) On right, deceased with wife and mother under sunshades, accompanied by attendants on either side (including man with two dogs), and remaining registers of agriculture (from left to right), **I** (upper part lost), ploughing, **II**, bringing donkeys, loading and transporting produce with donkeys, men carrying and stacking sheaves, **III**, pulling and binding flax, reaping corn, with flute-player and trapping birds, **IV**, stacking sheaves, threshing with sheep, donkeys and cattle, with shepherd's song above, piling up straw and winnowing grain.

[DARESSY, 552-3] DUELL, ii, pls. 166-70. **I-IV**, WRESZ., *Atlas*, iii. 46-7. **II-IV** (omitting right ends), ALDRED in PIGGOTT, *The Dawn of Civilization*, pl. on pp. 120-1 [52]. Flute-player

and three reapers in III, BAUMANN, *Die Welt der Pharaonen* (1959), pl. on p. 54 [lower]. Text of shepherd's song in IV, KAPLONY in *Chron. d'Ég.* xlv (1969), pp. 30 [M], cf. 27-8; ALTENMÜLLER in *ib.* xlviii (1973), pp. 212 [2], cf. 211. Some texts, ERMAN, *Reden, Rufe und Lieder*, pp. 22 [10-12], 24 [6], 25 [2, 6, 10], 26 [2, 7], 27 [6].

(81) (upper part lost) Deceased and family in canoe pulling papyrus in marshes, with attendants and son Memi (name erased) and brother Iḥy behind, and [men in canoe spearing fish] before them.

[DARESSY, 554] DUELL, ii, pls. 127-9. Omitting three attendants, WRESZ., *Atlas*, iii. 108 [B, C], 105 [C]. Prow of canoe of deceased, with birds, crocodile, and otter eating fish, *id. Bericht*, Taf. 75 [A]; LAUER, *Saqqara*, pl. 39. Otter, KEIMER, *Études d'Égyptologie*, iv (1942), fig. 1, pp. 1, 4-5.

Pillars.

(82)-(86) On all faces, name and titles and deceased at bottom (with son Meryteti at (83)(a)).

[DARESSY, 554] DUELL, ii, pls. 173-88. (84)(b) CAPART, *Memphis*, fig. 304 [right]; LANGE and HIRMER, *Aegypten. Architektur*, pl. 75; DE CENIVAL, *Living Architecture: Egyptian*, pl. 40; *Great Museums*, pl. 147 [right]; BUHL in *Mélanges de l'Université Saint-Joseph*, xlv (1969), pl. i [right], p. 200.

Store-rooms $\left(\begin{smallmatrix} \searrow \\ \text{---} \\ \swarrow \end{smallmatrix}\right)$ XV, XVII-XX.

(87)-(91) Doorways with names of phylai above.

[DARESSY, 552] View, DUELL, ii, pl. 199 [A]. Texts, *id. ib.* ii, pl. 199 [B].

Burial chamber. Opening of shaft in Room XI. Painted decoration.

FIRTH and GUNN, *Teti Pyr. Cem.* i, pp. 23-6. Plan and section, *id. ib.* fig. 19; DUELL, ii, pages before pl. 200. Views, *id. ib.* ii, pl. 200; FIRTH and GUNN, *op. cit.* ii, pl. 2; GUNN MSS. xviii. 16 [1] (photo.).

Doorway. Thicknesses with ten lines of text. DUELL, ii, pl. 211; text of south thickness, FIRTH and GUNN, *op. cit.* i, p. 143.

Walls. Offerings, offering-lists and offering-texts. DUELL, ii, pls. 201-8; GUNN MSS. xviii. 10-15, 16 [2], 17, 18 (photos.); texts, FIRTH and GUNN, *op. cit.* i, pp. 144-9. East and parts of north wall, *id. ib.* ii, pls. 3, 4. Geese as offerings, from south wall, SAMEH, *Daily Life*, fig. on p. 65 [upper]; BOULANGER, *Ägyptische und Altorientalische Malerei*, pl. on p. 19 (upside down). Decoration on wall east of sarcophagus, DUELL, ii, pl. 209.

Sarcophagus. Texts, *id. ib.* ii, pl. 210; FIRTH and GUNN, *op. cit.* ii, pl. 60 [3-8]; i, pp. 149-50.

Finds

Two offering-tables, fragments, alabaster, in Cairo Mus. JE 63195-6. GUNN MSS. xviii. on 19 [1] (photo.); texts, FIRTH and GUNN, *op. cit.* ii, pl. 65 [1, 2]; i, p. 26 [iv].

Bowl, fragments, alabaster, in Cairo Mus. JE 63197. *Id. ib.* ii, pls. 13 [B, middle], 65 [3]; i, p. 26 [vii] with fig. 20 [9].

Fragment of head-rest, alabaster. *Id. ib.* ii, pls. 13 [B, left lower], 65 [4]; i, p. 24 [top].

B. Wife WAḤTETKHET-ḤOR.

Texts and description, ČERNÝ Notebook, 119, pp. 2-15. Description, DUELL, i, pp. 1-2.



Room I.

(92) Wife with small son Meryteti, and three registers of offering-bringers.

[DARESSY, 555-6]

(93) [1st ed. 37] Registers, **I**, lost, **II**, tending cattle, including milking, bull mounting cow, calving, and men overthrowing bulls, **III**, offering-bringers, some with fish, in boats, **IV**, two scenes of netting fish.

[DARESSY, 556] **II-IV**, WRESZ., *Atlas*, iii. 95. Text above calving scene, ERMAN, *Reden, Rufe und Lieder*, p. 31 [4].

(94) [1st ed. 38] Wife with small son Meryteti and daughter . . . ibnub  , with female attendants behind.

[DARESSY, 556] Empty palanquin carried by four women, WRESZ., *Atlas*, iii. 11 [A].

(95) Wife with small son Meryteti, and four registers of offering-bringers.

Room III.

(96) Doorway. (a) and (b) Three registers, **I**, man leading bull, **II-III**, offering-bringers.

[DARESSY, 557]

(97) and (98) Wife with small son Meryteti, and five registers, offering-bringers and butchers at (97), and men bringing oryxes and bulls at (98).

(99) Wife with small son Meryteti, and four registers of estates.

[DARESSY, 557] Names, JACQUET-GORDON, *Domaines*, pp. 414-15 [36S6], cf. figs. 173-4.

(100) [1st ed. 39] (partly above doorway) Wife seated, and five registers of female dancers.

I-V, WRESZ., *Atlas*, iii. 29. Two dancers in **IV**, id. *Bericht*, Taf. 77 [top]; some dancers, HICKMANN in *Bull. Inst. Ég.* xxxvii [1] (1954-5), figs. 7, 21, 23 on pp. 171, 185, 187, and fig. 8 on p. 78; id. *Musicologie pharaonique*, figs. 7, 21, 23 on pp. 133, 147, 149. Love-poem in **IV**, see DRIOTON in *Rev. d'Ég.* 13 (1961), pp. 139-41 (text). Some texts, ERMAN, *Reden, Rufe und Lieder*, p. 60 [7].

(101) (partly above doorway) Wife and small son Meryteti, and offering-bringers.

(102) Wife and small son Meryteti, and six registers of offering-bringers.

Room V.

(103) Doorway. (a) and (b) Three registers, **I**, man leading bull, with ibex at (a) and gazelle at (b), **II-III**, offering-bringers. [DARESSY, 558]

(104) Wife and small son Meryteti, and three registers with an offering-bringer in each.

[DARESSY, 558]

(105) and (107) Four registers with priests and offering-bringers. [DARESSY, 560]

(106) Niche. (a) and (b) Wife at table, with offering-list (lost at (a)) and offering-bringers. (c) [1st ed. 40] False-door of wife.



[DARESSY, 558-9] (b) and (c) LAUER, *Saqqara*, pl. 42. (b) Upper part of wife, BOULAT, *A Close Up of Egypt*, pl. on pp. 44-5. (c) Lower part, CLARKE and ENGELBACH, *Ancient Egyptian Masonry*, fig. 187.

(108) Wife and son Meryteti in palanquin carried by female attendants, with men and women on either side, dogs and monkey below, and register of female attendants with chests with oil-jars and other articles at bottom.

[DARESSY, 560] WRESZ., *Atlas*, iii. 11.

(109) [1st ed. 41-2] Wife and son Meryteti, and registers, **I-II**, [offering-bringers], **III-IV**, butchers.

[DARESSY, 560] **III-IV**, WRESZ., *Atlas*, iii. 93 [A]. Some texts, ERMAN, *Reden, Rufe und Lieder*, pp. 8 [7], 10 [5], 11 [1, 10], 16 [8].

C. Son MERYTETI  MERI , Chief Justice and Vizier, King's eldest son of his body, Inspector of prophets of the Pyramid of Pepy I, etc. Temp. Pepy I or later.

Chapel.

Texts and description, ČERNÝ Notebook, 119, pp. 16-37. Description, DUELL, i, pp. 2-3.

Room I.

(110) Doorway. (a) and (b) Meryteti, and name and titles. [DARESSY, 561]

(111) (partly above doorway) Meryteti with son Ihyemsaf , and registers of offering-bringers. [DARESSY, 561]

(112) Registers, I-V (above doorway), hunting in desert, VI and VII (left of doorway), gazelle and ibex.

WRESZ., *Atlas*, iii. 101, cf. Textabb. 90 and 101,1 on pp. 188, 224. Two lions seizing gazelles, in I, SMITH, *Hist. Eg. Sculpt.* fig. 92b, p. 192.

(113) Meryteti leaning on staff, with son Ihy(emsaf), followed by seven registers of attendants, and seven registers of men bringing wild animals before them.

[DARESSY, 562-3] WRESZ., *Atlas*, iii. 90.

(114) Meryteti with wife Nebt , Prophetess of Hathor Mistress of the Shrine of the Southern Sycamore, and offering-bringers. [DARESSY, 563]

(115) (above doorway) Meryteti carried in palanquin.

(116)-(117) Upper part, Meryteti with wife carried in palanquin. Lower part, (116) men bringing animals, (117) registers, I-II, poultry-yard, III-V, men feeding fowl.

Upper part. WRESZ., *Atlas*, iii. 8 [A].

Lower part. (116) [DARESSY, 563]. (117) [DARESSY, 564] WRESZ., *Atlas*, iii. 76-7; left part of III-V, RANKE, *The Art of Ancient Egypt*, and BREASTED, *Geschichte Aegyptens* (1936), 192; CAPART, *Memphis*, fig. 378. Feeding cranes in V, SPIEGEL, *Hochkultur*, Taf. 57 [upper].

Room III.

(118) and (119) Meryteti at table, with offering-list, priests and offering-bringers. [DARESSY, 564-8]

(120) False-door of Meryteti. [DARESSY, 568-70]

(121) [1st ed. 43] Registers of offerings, offering-bringers and butchers.

[DARESSY, 570-1] Some texts of butchers, ERMAN, *Reden, Rufe und Lieder*, pp. 7 [15], 8 [4], 13 [1], 15 [3].

Room IV.

(122) and (123) Meryteti with wife by his legs, and registers of men bringing clothing, oils and jewelry before and behind them.

(122) [DARESSY, 571-2]. (123) [DARESSY, 572-3]

(124) Meryteti, and four registers of men bringing clothing and oil-jars.

(125) Meryteti and son Ihyemsaf, and four registers of men (bringing chests with clothing at bottom). [DARESSY, 573-4]

Burial chamber.

Sarcophagus. See SAAD in *Ann. Serv.* xliii (1943), p. 452.

Loose blocks.

One, with wife smelling lotus, FIRTH and GUNN, *Teti Pyr. Cem.* ii, pl. 20 [E]. Texts of others, id. ib. i, pp. 139-42 [Nos. 1-18, 21].

KANENEBFUI  KHENU [I] , Overseer of Upper Egypt, Overseer of the Two Granaries, etc. Dyn. VI.

Map LII.

False-door (top lost), side-pieces with deceased at bottom, and offering-table. FIRTH and GUNN, *Teti Pyr. Cem.* ii, pls. 74 [1], 76 [2-4], cf. view, pl. 17 [B]; i, pp. 186-7 [14], 209 [13], 270 [1]; DUELL, *The Mastaba of Mereruka*, ii, pl. 219 [B]; false-door, GUNN MSS. xviii. 42 [1] (photo.).

KHENU [II]  THEMI , Lector-priest, etc. Dyn. VI.

Map LII.

FIRTH and GUNN, *Teti Pyr. Cem.* i, p. 42, with plan, fig. 49, and views, ii, pl. 17 [A, B].

Obelisk, with base with offering-basin, in Cairo Mus. CG 17006. KUENTZ, *Obélisques (Cat. Caire)*, pl. v, pp. 12-14 with figs.; FIRTH and GUNN, op. cit. ii, pls. 17 [E], 77 [lower left], 78 [3]; i, p. 216 [1].

Two wooden statuettes of deceased. Id. ib. ii, pl. 17 [C] (*in situ*); one, in Cairo Mus. JE 47775, id. ib. ii, pl. 17 [F]; i, p. 42 [2]; HORNEMANN, *Types*, i, pl. 183.

THETHU , Chief Justice and Vizier, Tenant and Inspector of prophets of the Pyramid of Pepy I, etc. Probably late Dyn. VI.

Map LII. Plan LIV.

FIRTH and GUNN, *Teti Pyr. Cem.* i, pp. 28-30, 151-4; plans and section, figs. 30, 72 [top]. Blocks with deceased and titles, from frieze. Texts, id. ib. i, pp. 156, 291.

Chapel.

(1) Offering-bringers. Remains of texts, id. ib. i, p. 156.

(2) [1st ed. 4-5] Deceased at table, with offerings, priests and offering-bringers. Deceased, id. ib. ii, pl. 38. Texts, id. ib. i, pp. 154-5.

(3) [1st ed. 2-3] False-door.

Id. ib. ii, pl. 61; i, p. 154; GUNN MSS. xviii. 9 [2] (photo.).

Burial chamber.

Sarcophagus. Texts, FIRTH and GUNN, op. cit. i, p. 156.

Jar-lid of Pepy I, alabaster, in Cairo Mus. JE 47037. Id. ib. ii, pl. 13 [A]; i, pp. 28, 30 [iv], 169 [8].



Intrusive burial. See id. ib. i, pp. 31 [top], 48 [HMK. 5].

False-door of Imhôtep , Lector-priest, etc., 1st Int. Period. Id. ib. ii, pl. 67 [1]; i, pp. 38 [bottom], 181; GUNN MSS. xviii. 41 [2] (photo.).

Head-rest, inscribed (no name), alabaster, Dyn. VI, re-used. FIRTH and GUNN, op. cit. ii, pls. 14 [3], 65 [10] (text); i, p. 169 [9].

HMK. 140. 1st Int. Period.

FIRTH and GUNN, *Teti Pyr. Cem.* i, pp. 56-7 with fig. 62.

Fragments of rectangular wooden coffins of Teti-ħirmaa-neferuptah  and Sit-wernu  (woman). Texts, id. ib. i, pp. 259-60 [15, 16] with fig. 99.

HMK. 125. NEBI , Chief of the estate, etc. 1st Int. Period.

Remains of wooden coffin. Text, FIRTH and GUNN, *Teti Pyr. Cem.* i, pp. 265 [22, 1], cf. 56.

HMK. 120. SETHU , Lector-priest. 1st Int. Period.

Wooden rectangular coffin, fragments. Text, id. ib. i, pp. 265-6 [22, 2], cf. 56.

Burial No. 47. THAI , Regulator of a phyle of the Pyramid of Merykarē. 1st Int. Period.

FIRTH and GUNN, *Teti Pyr. Cem.* i, p. 47.



Wooden rectangular coffin, incomplete. Text, id. ib. i, pp. 257 [12], cf. 47.

Part of canopic-box, wood. Text, id. ib. i, p. 269 [8].

HMK. 69. IPIĤIRSESENBEP  IPI. 1st Int. Period.

Id. ib. i, p. 55 with fig. 61; view, ii, pl. 32 [A].

Rectangular wooden coffin. Id. ib. ii, pl. 32 [B, C]; i, pp. 239-45 [6] (texts); coffin-texts, DE BUCK, *Coffin Texts*, iv, Sq 4 Sq.

HMK. 30. GEMNIEMĤĤT  GEMNI , Regulator of a phyle of the Pyramids of Teti and Merykarē, etc. 1st Int. Period.

False-door, in Copenhagen, Ny Carlsberg Glypt. Æ.I.N. 1616. FIRTH and GUNN, *Teti Pyr. Cem.* ii, pl. 27 [B]; i, pp. 187-8 [16]; MOGENSEN, *Coll. ég.* pl. xcvi [A 681], p. 91; KOEFOED-PETERSEN, *Les Stèles égyptiennes*, pl. 7, pp. 4-6 [7], 70, xiv-xv. Text, id. *Rec. inscr.* pp. 40-1.

Burial chamber. Contents in Copenhagen, Ny Carlsberg Glypt., unless otherwise stated.

FIRTH and GUNN, op. cit. i, pp. 52-4, with view, ii, pl. 22 [A, B]. Plan and section, id. ib. i, figs. 57-8; MOGENSEN, op. cit. fig. on p. 67 (from FIRTH and GUNN).

Rectangular coffins, wood, present location of outer one unknown, inner, Æ.I.N. 1615. Both, FIRTH and GUNN, op. cit. ii, pls. 22 [C, D], 23-6; i, pp. 227-31 [1, 2]; GUNN MSS. xviii. 21-8, 29 [1] (photos.). Æ.I.N. 1615, MOGENSEN, op. cit. pls. lxxv, on lxiv [A 514], p. 67; KOEFOED-PETERSEN, *Catalogue des sarcophages et cercueils égyptiens*, pls. xi-xviii, pp. 12-13 [3], 46.

Canopic-box, wood, Æ.I.N. 1623. MOGENSEN, op. cit. pl. lxxvii [A 528], p. 69; GUNN MSS. xviii. 30-1 (photos.). Text, FIRTH and GUNN, op. cit. i, pp. 267-8 [3], cf. 53 [22].

Two wooden statuettes, Æ.I.N. 1626-7. Id. ib. ii, pl. 29 [B, left and right], p. xii; i, p. 53 [12]; MOGENSEN, op. cit. pl. lxxvii [A 521-2], p. 69; KOEFOED-PETERSEN, *Cat. des statues*, pl. 18, p. 14 [16].

Models. Wood.

Rowing-boat, Æ.I.N. 1629. FIRTH and GUNN, op. cit. ii, pl. 29 [A]; i, p. 53 [11]; MOGENSEN, op. cit. pl. lxvi [A 517], p. 68; GÖTTLICHER and WERNER, *Schiffsmodelle im Alten Aegypten*, Taf. xvi [1]. See BREASTED (Jr.), *Eg. Servant Statues*, p. 75 [A, 2].

Granary, Æ.I.N. 1630. FIRTH and GUNN, op. cit. ii, pl. 30; i, pp. 53 [7], 272 [9]; MOGENSEN, op. cit. pl. lxvi [A 515], pp. 67-8; BREASTED (Jr.), op. cit. pl. 10, p. 13 [3]; KOEFOED PETERSEN, *Det gamle Ægypten* (1943), fig. on p. 10; POSENER, SAUNERON and YOYOTTE, *Dict. civ.* fig. on p. 94; WHITE, *Everyday Life in Ancient Egypt*, fig. 85; GUNN MSS. xviii. 29 [2], 32 (photos.).

Butchers, brewers and bakers, Æ.I.N. 1631. FIRTH and GUNN, op. cit. ii, pl. 31 [A, B]; i, p. 53 [8]; MOGENSEN, op. cit. pl. lxvi [A 520]; BREASTED (Jr.), op. cit. pl. 40 [b], p. 41 [4].

Storehouse and brewery, Æ.I.N. 1632. FIRTH and GUNN, op. cit. ii, pl. 28 [A, B]; i, p. 53 [6]; MOGENSEN, op. cit. pl. lxvi [A 519], p. 69; BREASTED (Jr.), op. cit. pl. 32 [c], pp. 16 [Type 3, 1], 34 [2].

Carpenters, blacksmiths and potter, Æ.I.N. 1633. FIRTH and GUNN, op. cit. ii, pl. 29 [C]; i, p. 53 [10]; MOGENSEN, op. cit. pl. lxvi [A 518], pp. 68-9; BREASTED (Jr.), op. cit. pl. 46 [b], p. 51 [Type 3, 1].

Spinners and weavers, Æ.I.N. 1634. FIRTH and GUNN, op. cit. ii, pl. 31 [C]; i, p. 53 [9]; MOGENSEN, op. cit. pl. lxvi [A 516], p. 68; BREASTED (Jr.), op. cit. pl. 47 [b], pp. 52-3 [1].

Two female offering-bringers, Æ.I.N. 1628. FIRTH and GUNN, op. cit. ii, pl. 29 [B, middle]; i, p. 53 [13]; MOGENSEN, op. cit. pl. lxvii [A 524], p. 69; BREASTED (Jr.), op. cit. pl. 52 [a], p. 62 [2]; KOEFOED-PETERSEN, *Cat. des statues*, pl. 19, pp. 14-15 [17].

Flax-workers and probably barbers, in Cairo Mus. JE 47929. FIRTH and GUNN, op. cit. ii, pl. 28 [C]; i, p. 53 [10A]. See BREASTED (Jr.), op. cit. pp. 55 [Type 3, 1] (as Copenhagen), 56 [Type 1, 1].

HMK. 37. DUAUḤOTP , Noblewoman of the King, etc. 1st Int. Period.

False-door of deceased and Sit-gemni , Prophetess of Ḥathor, etc. FIRTH and GUNN, *Teti Pyr. Cem.* ii, pl. 75; i, p. 188 [17]; GUNN MSS. xviii. 33 [2], 44 [2] (photos.).

Rectangular wooden coffin of deceased. Texts, FIRTH and GUNN, op. cit. i, pp. 258-9 [14], cf. 54.

Burial No. 81. ḤERIMERU , Royal chamberlain, etc. Late Dyn. VI or 1st Int. Period.

FIRTH and GUNN, *Teti Pyr. Cem.* i, pp. 39-40, with plan, fig. 46.

Wooden rectangular coffin. Text, id. ib. i, pp. 253-6 [10].

Head-rest, alabaster. Id. ib. ii, pls. 14 [4], 65 [11]; i, pp. 40, 270 [3].

Plank from wooden canopic-box. Text, id. ib. i, p. 268 [6].

SITINTETI  or SITIN, Prophetess of Ḥathor, King's sole adorer.

End of Dyn. VI or 1st Int. Period.

Map LII.

FIRTH and GUNN, *Teti Pyr. Cem.* i, p. 38, cf. fig. 53.

Niche with two side-pieces, (a) deceased at table, offering-list, and priests, with butchers, (b) similar to (a), with overthrowing ox, and female offering-bringers, (c) false-door, with

uninscribed offering-table on re-used block with woman smelling lotus, all in Boston Mus. 24.593. Niche, id. ib. ii, pls. 21, cf. 20 [C]; i, pp. 185-6 [12], 203-4 [1]; SIMPSON in *North Carolina Museum of Art. Bulletin*, xi [3] (Dec. 1972), figs. 7-11, pp. 8-9; GUNN MSS. xviii. 33 [1], 34-5 (photos.); overthrowing ox at (b), FISCHER in *Artibus Asiae*, xxii (1959), fig. 8, p. 250. Offering-table, FIRTH and GUNN, op. cit. ii, pls. 20 [D], cf. 20 [C]; i, p. 142 [20].

HMK. 26. Family-tomb of IPI^cANKHU $\text{𓂏} \square \text{𓂏} \text{𓂏}$. 1st Int. Period.

Monuments of Ipi^cankhu Ipi, Steward.

False-door; FIRTH and GUNN, *Teti Pyr. Cem.* ii, pl. 67 [2]; i, pp. 181-2 [2]; GUNN MSS. xviii. 41 [1] (photo.). Side-piece, registers, I, man leading bull, II, offering-bringers, III, butchers, IV, man with geese before deceased; GUNN MSS. R.2.1 (painting), Notebook, 11, No. 89.

Monuments of Ipi^cankhu, various titles. Perhaps connected with this tomb.

Fragment of false-door, side-piece and block. Texts, FIRTH and GUNN, op. cit. i, pp. 199 [31], 208 [8], 213 [5].

Burial chamber. Usurping shaft of Sitinteti, see above.

Id. ib. i, pp. 50-1, with plan and section, figs. 53-4.

Two rectangular wooden coffins (B of Firth and Gunn) of Ipi^cankhu, Scribe of the expedition, and a coffin (A) of Ipi^cankhu, no title, one of them in Cairo Mus. Temp. No. 19.8. 23.1. GUNN MSS. xviii. 36-9 (photos.). Texts, FIRTH and GUNN, op. cit. i, pp. 231-9 [3-5]; of one (4 of FIRTH and GUNN), DE BUCK, *Coffin Texts*, v, vi, Sq 5 Sq.

Two canopic-boxes, wood. Texts, FIRTH and GUNN, op. cit. i, p. 267 [1, 2].

Two alabaster head-rests, in Cairo Mus. JE 8859-60. Id. ib. ii, pl. 14 [E, 5, 7]; i, p. 270 [4, A, C].

Statuette of scribe, from model granary. Scribe's board, GUNN MSS. xviii. 40 (photos.); FIRTH and GUNN, op. cit. i, fig. 102, pp. 271-2 [8], 51 [ii].

HMK. 6. KHUIT-KHNUM $\text{𓂏} \text{𓂏} \text{𓂏}$ (woman). 1st Int. Period.

FIRTH and GUNN, *Teti Pyr. Cem.* i, pp. 48-50 with figs. 51-2.

Rectangular wooden coffin, fragments. Texts, id. ib. i, p. 258 [13].

Plank from canopic-box. Text, id. ib. i, pp. 268-9 [7].

Burial No. 227. PTAḤEMḤĒT $\text{𓂏} \text{𓂏} \text{𓂏}$, Inspector of King's hairdressers, etc. Late Dyn. VI or 1st Int. Period.

Id. ib. i, pp. 41-2 with fig. 47.

Rectangular wooden coffin. Id. ib. ii, pls. 79, 80; i, pp. 245-6 [7].

Burial No. 225. IPI $\text{𓂏} \square \text{𓂏}$, Physician of the Great House. Late Dyn. VI or 1st Int. Period.

Id. ib. i, pp. 40-1.

Deceased on base of double statuette, wood, in Cairo Mus. JE 47774. Id. ib. ii, pl. 19 [A, B]; i, pp. 40 [1, 2], 271 [7].



PEḤERNŪFER  †, Prophet of Rē̄c in the Sun-temple of Userkaf, etc. Dyn. V or VI.

West of tb. of Mereruka.

False-door. SAAD in *Ann. Serv.* xliii (1943), pl. xxxviii [A], pp. 452-3.

KAEMSENU , *warb*-priest of Saḥurē̄c, *warb*-priest of the Pyramid of Neuserrēc, Prophet of Rē̄c in the Sun-temple of Neferirkarē̄c, etc. Dyn. VI.

Map LII.

Father, Seḥotpu  , *warb*-priest of the Pyramid of Saḥurē̄c, Prophet of Rē̄c in the Sun-temple of Neferirkarē̄c, etc. Wife, Irt-nub , Prophetess of Ḥathor, etc.

FIRTH and GUNN, *Teti Pyr. Cem.* i, pp. 31-6; plan, ii, on pl. 51; view, ii, pl. 16 [A]; titles, i, pp. 157-8, 165.

Chapel of Kaemsenu.

Doorway. Lintel with offering-text, and drum with name and title; id. ib. ii, pl. 63 [2, 3]; i, p. 159 [1].

East wall (painted decoration). Remains of offering-bringers, butchers and men bringing animals. Texts, id. ib. i, p. 164.

South wall (painted decoration). Deceased at table, with harpists and singers. Texts, id. ib. i, pp. 163-4.

West wall. Architrave with offering-text, and below (from left), man before deceased with wife and son, false-door, offering-list, and false-door of Werzedptah , King's *warb*-priest, etc., in New York, M.M.A. 26.9.1. Id. ib. ii, pls. 62, 63 [1]; i, pp. 159-63; HAYES, *Scepter*, i, fig. 60; id. in *M.M.A. Bull.* n.s. iv (March 1946), fig. on p. 177, cf. p. 178; inner part of false-door of Kaemsenu, GUNN MSS. xviii. 42 [3] (photo.); hieroglyphs, RANSOM WILLIAMS, *The Decoration of the Tomb of Per-nēb*, pls. i, ii; titles on left inner jamb of false-door of Kaemsenu and offering-text left of it, SETHE, *Urk.* i. 175 [20 (III), A, B].

Wooden statues. Uninscribed. In New York, M.M.A.

In situ, FIRTH and GUNN, op. cit. ii, pl. 18 [A]; i, pp. 31-2, cf. fig. 33.

Standing, No. 26.9.2. Id. ib. ii, pl. 18 [C, D]; LANSING in *M.M.A. Bull.* xxiii (1928), fig. 1 on p. 159; WINLOCK, *Egyptian Statues and Statuettes* (1937), fig. 1; SCOTT, *Egyptian Statues* (1945), on 4th pl.; *I.L.N.* Dec. 29, 1945, fig. on p. 724 [upper middle]; HAYES, *Scepter*, i, fig. 66; ALDRED, *O.K. Art*, pl. 58; MICHALOWSKI, *Art*, fig. 231.

Seated, No. 26.9.3. FIRTH and GUNN, op. cit. ii, pl. 18 [B].

Chapel of Seḥotpu.

False-door, with dedication-texts of sons Kaemsenu and Washptah , Id. ib. ii, pl. 63 [5]; i, p. 165 [2]; GUNN MSS. xviii. 42 [2] (photo.); dedication-texts, SETHE, *Urk.* i. 176 [20 (III), D].

Lintel with offering-text and dedication of sons. FIRTH and GUNN, op. cit. ii, pl. 63 [4]; i, p. 165 [1]; dedication, SETHE, *Urk.* i. 176 [20 (III), C].

Shafts.

No. 240. Eleven model boats with accessories, wood, in Cairo Mus. JE 63183-94; FIRTH and GUNN, op. cit. ii, pl. 49; i, p. 33, cf. fig. 35; POUJADE, *Trois flotilles de la VI^{ième} Dynastie des Pharaons*, pls. viii-x, pp. 33-40 with figs. 20-7 bis.

No. 255. Sealing of Isesi, on bundle of reeds; see FIRTH and GUNN, *op. cit.* i, pp. 32-3 (as shaft No. 233), 36, 169 [7], cf. fig. 43.

KAEMḤEST , King's architect and builder, etc. Probably early Dyn. VI.

Map LII. Plan LVII.

Father, Senefcankh , King's architect and builder. Wife, Thenenet.

QUIBELL and HAYTER, *Teti Pyramid, North Side*, pp. 16-20; plan, on pl. 1; view, pl. 27 [1].

South Chapel. Kaemḥest.

Pillared Room. Painted decoration.

One pillar, *id. ib.* pl. 27 [2]; GUNN MSS. xiv. 25 [3] (photo.).

(1) Remains of deceased and wife, and registers with boat, animals, etc. QUIBELL and HAYTER, *op. cit.* fig. on p. 17.

(2) Remains of two registers, with man carrying jars on yoke in the lower one. *Id. ib.* fig. on p. 18 [upper].

(3) Deceased, and remains of name and titles.

Id. ib. fig. on p. 18 [lower]; remains of titles, GUNN Notebook, 24, p. 3.

(4) Deceased and wife seated. See QUIBELL and HAYTER, *op. cit.* p. 18.

(5) [1st ed. 4] Siege of fortified settlement.

Id. ib. frontispiece; scaling party, CLARKE and ENGELBACH, *Ancient Egyptian Masonry*, fig. 83.

Statues. In Cairo Museum.

Statue-group, deceased and wife seated, with small son, JE 44173. QUIBELL and HAYTER, *op. cit.* pl. 28, pp. 18, 43; HORNEMANN, *Types*, v, pl. 1418; Zürich. *5000 Jahre*, Abb. 32, p. 59 [117]; London. *5000 Years*, pl. ix, p. 14 [25]; Brussels. *5000 ans*, fig. 10, p. 23 [14]; Essen. *5000 Jahre*, No. 32 with Abb.; Amsterdam. *5000 jaar*, fig. 6 [21]; Louisiana. *5000 ârs*, No. 62 with fig.; HARRIS in *Apollo*, lxxvi (1962), fig. 3 on p. 351; PERC, *Spomeniki starega Egipta* (1974), No. 11 with fig.; GUNN MSS. xiv. 27 (photo.).

Deceased, probably originally in niche at (3), JE 44174. QUIBELL and HAYTER, *op. cit.* pl. 29, pp. 18, 44; HORNEMANN, *Types*, i, pl. 131.



Base and feet of wooden statue of deceased, JE 44137. QUIBELL and HAYTER, *op. cit.* pl. 27 [3], pp. 19, 43. Text, GUNN Notebook, 24, p. 1 [top].

Various finds.

Wooden drum with name and titles, in Cairo Mus. JE 44175. GUNN MSS. xiv. 25 [1, 2] (photos.), Notebook, 24, p. 1 [middle]; text, QUIBELL and HAYTER, *op. cit.* p. 19 [top].

Offering-basin. See *id. ib.* p. 19 [middle]. Text, perhaps from another, GUNN Notebook, 24, p. 1 [bottom].

Wooden cylinder seal of Pepy I, in Cairo Mus. JE 72625. QUIBELL and HAYTER, *op. cit.* fig. on p. 19; GOEDICKE in *Mitt. Kairo*, 17 (1961), Taf. xxi [XXIV], p. 90.

Wooden door-wing with deceased and Hetepka  (perhaps son and dedicator), and ext mentioning Kaemḥest (deceased), Kapunesut, Memi , Hetepka, and Kakhent

𓆎𓆏𓆐𓆑𓆒 (all five sons of Seneftankh), made by Ithu 𓆑𓆒, Sculptor, from mastaba west of Kaemhest, in Cairo Mus. JE 47749. CAPART, *Documents*, i, pl. 13; CLARKE and ENGELBACH, *Ancient Egyptian Masonry*, fig. 185; ZAYED, *Trois études d'égyptologie*, pp. 8-10 with fig. 8; KEES in *W.Z.K.M.* 54 (1957), Abb. 1 (from ZAYED), pp. 91-4; GUNN MSS. xiv. 28, xv. 4 (with photos.). Upper part of deceased, *Encycl. phot. Caire*, pl. 41; FORMAN (W. and B.) and VILÍMKOVÁ, *Eg. Art*, pl. 25; DONADONI, *Egyptian Museum Cairo*, pl. on p. 57 [lower]; SÉE, *Naissance*, fig. on p. 54. Texts, SETHE, *Urk.* i. 206-7 [42 (133)]. Name of estate, JACQUET-GORDON, *Domaines*, pp. 408-9 [33S6], cf. figs. 168-9; of sculptor, GUNN in *Ann. Serv.* xxvi (1926), p. 193 [bottom]. See *Descr. somm.* No. 6035.

Central Chapel. Brother Kapunesut 𓆑𓆒𓆓, King's architect and builder.

Wooden statues. From serdab.

View *in situ*, ZAYED, op. cit. fig. 4, p. 3; GUNN MSS. xiv. 29 (photo.).

Double-stature, deceased (head and arms lost) and son Sekhemka 𓆑𓆒𓆓 (feet only), in Cairo Mus. JE 67369, and sceptre with name and titles. ZAYED, op. cit. figs. 1-3, 6, 7, pp. 1-2, 4-8; GUNN MSS. xiv. 30 [1, 3] (photos.), Notebook, 25, No. 1. Base, KEES, op. cit. Abb. 2 (from ZAYED), cf. p. 94 note 7. See QUIBELL and HAYTER, op. cit. p. 20 [statue 1].

Deceased (left arm and base with feet lost), in New York, M.M.A. 26.2.7. ZAYED, op. cit. fig. 5, pp. 3-4; GUNN MSS. xiv. 30 [2] (photo.), Notebook, 25, No. 2; restored, SCOTT, *Egyptian Statues* (1945), 3rd pl.; *I.L.N.* Dec. 29, 1945, fig. on p. 725 [upper middle]; KEES, op. cit. Abb. 3, p. 94. See QUIBELL and HAYTER, op. cit. p. 20 [statue 2].

HMK. 159. MUT-ḤETEPI 𓆑𓆒𓆓 (woman). 1st Int. Period.

FIRTH and GUNN, *Teti Pyr. Cem.* i, p. 57 with fig. 63.

Burial Chamber.

Rectangular wooden coffin, incomplete. Text, id. ib. i, pp. 262-5 [20].

Two model rowing-boats, wood. See id. ib. i, p. 57 [1, 2]. One, in Neuchâtel Mus. Eg. 353; GABUS, *La Collection égyptologique* [etc.] in *Formes et Couleurs*, xi [1] (1949), 4th fig.; see id. *175 ans*, Pt. 1, p. 56 [16].

Model kitchen, wood, in Neuchâtel Mus. Eg. 354. Id. in *Formes et Couleurs*, xi [1] (1949), 2nd fig.; see id. *175 ans*, Pt. 1, p. 56 [12].

HMK. 40. SENENY 𓆑𓆒𓆓, Judge and Keeper of Nekhen, etc. 1st Int. Period.

FIRTH and GUNN, *Teti Pyr. Cem.* i, p. 55.

Wooden rectangular coffins, fragments. Inner; texts, id. ib. i, pp. 246-53 [8]; coffin-texts, DE BUCK, *Coffin Texts*, ii, Sq 3 Sq. Outer; text, FIRTH and GUNN, op. cit. i, p. 253 [9].

Fragment of canopic-box. Text, id. ib. i, p. 268 [4].

LATE DYN. VI AND 1ST INT. PERIOD FINDS

Statues.

Neferwaḥb 𓆑𓆒, son of Sitiḳer 𓆑𓆒 (mother), squatting statuette. Text, FIRTH and GUNN, *Teti Pyr. Cem.* i, p. 270 [2].

Bust of male statuette, wood, from Burial No. 33, in Cairo Mus. JE 47036. Id. ib. ii, pl. 19 [C]; i, p. 39.

Nude statuette, wood, from Burial No. 213. Id. ib. ii, pl. 19 [D]; i, p. 40.

Bases of four wooden statuettes of Gemni . Texts, id. ib. i, pp. 270-1 [6].

False-doors.

Ānkhtef . GUNN MSS. xiv. 45 [1] (photo.), 45A, and Notebook, 9, No. 12. Text, FIRTH and GUNN, *Teti Pyr. Cem.* i, pp. 194-5 [25].

Gemni , Tenant of the Pyramid of Pepy I, etc. Text, id. ib. i, pp. 197-8 [29].

Gemni Megui . Fragments of false-door; text, id. ib. i, p. 201 [46]. Block; text, id. ib. i, p. 214 [10].

Gem(ni)ānkh , Steward, in Berlin (East) Mus. 1151. L. D. Text, i, fig. on p. 152, cf. p. 151 [bottom]. Text, *Aeg. Inschr.* i, p. 47. See *Ausf. Verz.* pp. 61-2; *Führer* (1961), p. 45.

Gemniānkh . FIRTH and GUNN, op. cit. ii, pl. 74 [2]; i, p. 187 [15]; GUNN MSS. xviii. 45 [2] (photo.).

Gemni-iu , Judge and Overseer of scribes of the herds, etc. Fragments of false-door; text, FIRTH and GUNN, op. cit. i, pp. 201-2 [47]. Lintel; text, id. ib. pp. 210-11 [18].

Gemni-iy , Inspector of *ka*-servants, upper part. GUNN MSS. xviii. 41 [3] (photo.). Text, FIRTH and GUNN, op. cit. i, p. 199 [30].

Ĥarshefnakht , Overseer of the expedition, Director of a crew of recruits, etc. Text, id. ib. i, pp. 192-3 [22].

Ĥarshefnakht. Id. ib. ii, pl. 71 [1]; i, p. 183 [7]; GUNN MSS. xviii. 45 [1] (photo.).

Ĥarshefnakht, Steward, etc. False-door and side-piece, probably both of same man, in Stockholm Mus. MM. 11407-8; FIRTH and GUNN, op. cit. ii, pl. 71 [2]; i, pp. 184 [8] (false-door), 205-6 [3]; Stockholm. 5000 *år*, Nos. 43 with fig. (false-door), 42. MM. 11408, GUNN MSS. xviii. 50 [2] (photo.).

Ĥenuti , King's sole adorer (woman). FIRTH and GUNN, op. cit. ii, pl. 70 [2]; i, p. 183 [6]; GUNN MSS. xiv. 45 [3], xviii. 46 [1] (photos.).

Ĥepi , Lector-priest, fragment. Text, FIRTH and GUNN, op. cit. i, p. 201 [42].

Ĥetep, Director of the dining hall of the Great House, Overseer of the store-room. Id. ib. ii, pl. 73 [1]; i, p. 185 [11]; GUNN MSS. xviii. 47 [1] (photo.).

Ĥetepmert-teti , Ĥetepti (woman). FIRTH and GUNN, op. cit. ii, pl. 72 [1]; i, p. 184 [9]; GUNN MSS. xviii. 44 [1] (photo.).

Ĥkri , Scribe, two fragments. Text of one, FIRTH and GUNN, op. cit. i, p. 200 [35]; of another, GUNN MSS. on xv. 35a; Notebook, 11, No. 84.

Ĥku , Prophetess of Ĥathor, etc., fragments. Text, FIRTH and GUNN, op. cit. i, p. 200 [36].

Ĥmat , (woman), fragment. Text, id. ib. i, p. 200 [33].

Ĥpi, two stelae. Texts, id. ib. i, pp. 188-9 [18, 19].

Ĥpiemsas , Ĥpi, Prophetess of Ĥathor. False-door, id. ib. ii, pl. 68; i, p. 182 [3]; GUNN MSS. xviii. 48 [1] (photo.). Lower part of side-piece, in Cairo Mus. CG 1665; BORCHARDT, *Denkmäler*, ii, Bl. 88, pp. 123-4.

Ĥpiĥirsesenbef , Overseer of the expedition, Regulator of a phyle of the Pyramid of Teti, etc. Text, FIRTH and GUNN, op. cit. i, pp. 190-1 [20].



Ĥri , Inspector of the Royal House, lower part. Text, id. ib. i, p. 200 [34].

Ĥufenmutf , Sole companion, with lintel and side-pieces. Id. ib. ii, pl.

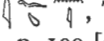

69; i, pp. 182 [4], 210 [15]; false-door, FISCHER in *A.Z.* 90 (1963), Taf. vii [a], p. 36; GUNN MSS. xviii. 49 [1] (photo.).

Iufni , Tenant of the Pyramid of Teti, etc., fragments. Text, FIRTH and GUNN, op. cit. i, p. 199 [32].

Khuit , Royal acquaintance (woman), in fragments. Text, id. ib. i, pp. 193-4 [23].

Ḳisutet  Niwezet-denu(?) , Prophetess of Ḥathor, etc., lower part. Text, id. ib. i, pp. 196-7 [28].

Mehyt , fragment. Text, id. ib. i, p. 201 [40].

Meryrē-cankh  Ḥeḳaib , Overseer of the King's house, etc. Id. ib. ii, pl. 64; i, pp. 20, 167-8 [2].

Meteti , Lector-priest. Text, id. ib. i, pp. 191-2 [21].

Nefertwa  (woman), fragments. GUNN MSS. xviii. 46 [2] (photo.); text, FIRTH and GUNN, op. cit. i, p. 201 [41].



Neithōtp . Id. ib. ii, pl. 72 [2]; i, p. 185 [10]; GUNN MSS. xviii. 48 [2] (photo.).

Pa-ani , upper part. Text, FIRTH and GUNN, op. cit. i, p. 200 [38].

Pa-ani, Overseer of the department of tenants, etc. Fragment of false-door; text, id. ib. i, p. 200 [39]. Lintel probably of same man; text, id. ib. i, p. 210 [17].

Seni , Overseer of tenants of the Great House, etc. Id. ib. ii, pl. 73 [2]; i, p. 186 [13]; GUNN MSS. xviii. 49 [2] (photo.).

Senti , King's daughter, upper part. Text, FIRTH and GUNN, op. cit. i, p. 195 [26].

Shedy-ptah  Shedu ; text, id. ib. i, p. 196 [27]. Architrave with three figures of deceased (with titles *warb*-priest of the two hundred of the Pyramid of Pepy II, etc.); GUNN Notebook, 11, No. 79; MSS. xv. 25.

Sit-gemni , King's sole adorer (woman), fragment. Text, FIRTH and GUNN, op. cit. i, p. 201 [45].

Sit-khemt  (woman), fragment. Text, id. ib. i, p. 201 [44].



Tetiemsaf . GUNN MSS. xiv. 45 [2] (photo.); Notebook, 9, No. 9. Text, FIRTH and GUNN, op. cit. i, p. 194 [24].

User , Great *warb*-priest, Inspector of prophets. Id. ib. ii, pl. 70 [1]; i, p. 183 [5]; GUNN MSS. xviii. 47 [2] (photo.).

Usermut , fragments. Text, FIRTH and GUNN, op. cit. i, p. 200 [37].

Name lost, with title connected with the Pyramid of Merykarē, fragments. Text, id. ib. i, p. 202 [51].

Side-pieces and lintels of false-doors.

Gemni , side-piece, with unguent-jars and jewelry, son offering goose to deceased and wife Ipi , deceased at table, and offering-bringers, in Cairo Mus. CG 1571. BORCHARDT, *Denkmäler*, ii, Bl. 71, pp. 43-4; FIRTH and GUNN, *Teti Pyr. Cem.* i, fig. 90, pp. 208-9 [12]; GUNN MSS. xvii. 2 (photo.).

Gemni, fragment of side-piece. See FIRTH and GUNN, op. cit. i, p. 210 [16].

Gemniemsaf , fragment of side-piece. Text, id. ib. i, p. 207 [7].

Ḥarshefnakht , side-piece. GUNN MSS. xviii. 50 [1] (photo.). Text, FIRTH and GUNN, op. cit. i, p. 206 [4].

Ḥeneni , lintel-fragment. Text, id. ib. i, p. 211 [20].

Meĥu , Scribe, lintel-fragment. Text, id. ib. i, p. 211 [19].

Nefertwa , (woman), fragment of side-piece. Text, id. ib. i, pp. 206-7 [5].

Nes-useri, block from tomb of Mereruka re-used as side-piece. Texts, id. ib. i, pp. 142 [19], 208 [9], cf. 38 note 1.

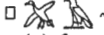
Pa-ani , Noble of the King, Companion of the house, side-piece and two fragments, (a) four registers of men offering, (b) man presenting haunch, (c) man presenting haunch and ox, and two men offering incense. Texts, id. ib. i, pp. 204-5 [2].

Sabu , fragment of side-piece. GUNN MSS. xviii. 51 [1] (photo.). Text, FIRTH and GUNN, op. cit. i, p. 207 [6].

Sit-khemt , (woman), side-piece. LILYQUIST, *Ancient Egyptian Mirrors*, fig. 136 (in the press); name, FISCHER in *A.Z.* 100 (1973-4), p. 23 note 33.

Lintel-fragment with remains of address. Text, FIRTH and GUNN, op. cit. i, p. 211 [21]; SETHE, *Urk.* i. 198 [35 (126)].

Two side-pieces, LILYQUIST, op. cit. figs. 123-4 (in the press).

Blocks.

Abebi , Lector-priest, etc., two figures of deceased and one of son. FIRTH and GUNN, *Teti Pyr. Cem.* ii, pl. 78 [1]; i, p. 213 [2].

Gemni , censuring to deceased. Sketch, GUNN Notebook, 10, No. 56. Text, FIRTH and GUNN, op. cit. i, pp. 214-15 [12].

Ĥetepheres , (woman) seated, and harvest scenes. Text, id. ib. i, pp. 168-9 [6].

Ipi , Steward, etc., represented three times. Text, id. ib. i, p. 213 [4].

Merypepy , Lector-priest, etc., son of Kagemni (tomb, p. 521), architrave-fragment with three figures of deceased and small son Kagemni, Noble of the King. GUNN MSS. xiv. 55 [2] (photo.); Notebook, 9, No. 13. Text, FIRTH and GUNN, op. cit. i, p. 167 [1].

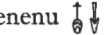
Nefersenenu , Steward, etc. at table, and sons as offering-bringers. Text, id. ib. i, p. 214 [11]; GUNN Notebook, 9, No. 5; 11, No. 82.

Pa-ani , and another man. Text, FIRTH and GUNN, op. cit. i, p. 215 [13].

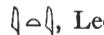
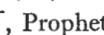

Rēĥterep , Iti , Lector-priest, etc., Honoured by Kagemni, two scenes, seated, with wife Ĥest , Prophetess of Ĥaĥor, behind, and with son censuring before them. Id. ib. ii, pl. 77 [A-E]; i, pp. 39, 212 [1]. Offering-text and address, SETHE, *Urk.* i. 197 [34 (125)].

Sefekhi , Overseer of smelters of gold, and another man. Text, FIRTH and GUNN, op. cit. i, p. 214 [8].

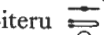
Senezem , Text, id. ib. i, p. 214 [9].

Sethet-iteru , Prophetess of Ĥaĥor, etc. smelling lotus. GUNN MSS. xviii. 50 [3] (photo.). Text, FIRTH and GUNN, op. cit. i, p. 213 [6].

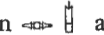
Sobki , Overseer of commissions of tenants of the Pyramid of Pepy I, and wife. Text, id. ib. i, pp. 213-14 [7].

Yunmin , and son Iby , Inspector of tenants of the Great House. Text, id. ib. i, p. 213 [3].

Two men with three female offering-bringers below. Text, id. ib. i, p. 215 [14].

Three, trapping birds, man drinking, and spinning, Dyn. VI. Id. ib. i, figs. on pp. 6, 10, 36.

Inscribed blocks, Dyn. VI. Id. ib. ii, pl. 66; i, p. 168 [3-5]; text of address (pl. 66 [1]), SETHE, *Urk.* i. 249-50 [11 (151)].

Coffins. Rectangular, wooden.

Gemni¹ , from S 2734. Name, QUIBELL and HAYTER, *Teti Pyramid, North Side*, p. 16.

Gemniemsaf , fragments. Text, FIRTH and GUNN, *Teti Pyr. Cem.* i, p. 261 [19].

Gemnihotp , two planks. Text, id. ib. i, p. 261 [18].

Ḥarshefnakht , incomplete. Text, id. ib. i, pp. 256-7 [11].

Ḥetepmer-teti , from S 2608.² Name, QUIBELL and HAYTER, op. cit. p. 8.

Imḥōtep , Sole companion, planks. Text, FIRTH and GUNN, op. cit. i, p. 260 [17].

Ipankhef¹ , from S 2748.² Name, QUIBELL and HAYTER, op. cit. p. 16.

Ipiem . . .¹ , from S 2745.² Name, id. ib. p. 16.

Itety , (woman). Text, L. D. *Text*, i, p. 159 [upper middle].

Khui¹ , from S 2608.² Name, QUIBELL and HAYTER, op. cit. p. 16.

Neferkhent¹ , from S 2741.² Name, id. ib. p. 16.

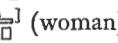

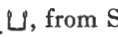

Neithotp , (woman), one plank. Remains of text, FIRTH and GUNN, op. cit. i, p. 265 [21].

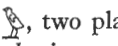



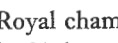

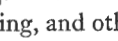
Sengerka¹ , from S 2740.² Name, QUIBELL and HAYTER, op. cit. p. 16.

Sit-wernu , (woman). Text, FIRTH and GUNN, op. cit. i, p. 266 [22, 3].

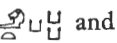
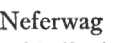
. . . ruu , two planks, in Berlin Mus. 13100. Text, L. D. *Text*, i, p. 159 [lower middle]; *Aeg. Inschr.* i, p. 134.

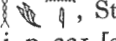
Offering-tables.³ Many fragmentary.

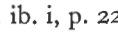
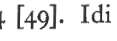
‘Ankh . . . , Royal chamberlain of the Great House; text, FIRTH and GUNN, *Teti Pyr. Cem.* i, p. 219 [8]. ‘Ashau  and Werekh; text, id. ib. i, p. 219 [9]. ‘Ash-heref , Noble of the King, and others; text, id. ib. i, p. 225 [52]. Gemni-ankhu ; text, id. ib. i, p. 224 [48]. Gemni-theses , Steward, etc.; id. ib. ii, pl. 11 [6]; i, p. 224 [47].

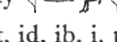
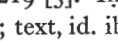
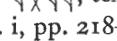
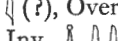
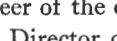
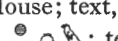
Ḥatkau  and Neferwag ; text, id. ib. i, pp. 220-1 [20]. Ḥeneni , Lector-priest, etc.; text, id. ib. i, p. 221 [25], cf. fig. 94. Ḥeni , Steward; GUNN MSS. xviii. 52 [1, right] (photo.); text, FIRTH and GUNN, op. cit. i, p. 221 [24]. Ḥetep . . . ; text, id. ib. i, p. 224 [49]. Idi ; text, id. ib. i, p. 219 [6]. Idu  and others; text, id. ib. i, p. 219 [7]. Idy , Noble of the King, etc., and wife; text, id. ib. i, p. 219 [5]. Ihy ; text, id. ib. i, p. 224 [51]. Ihy; text, id. ib. i, p. 225 [53]. Ikri ; text, id. ib. i, pp. 218-19 [3]. Imai ; text, id. ib. i, p. 218 [1]. Imy(?) , Overseer of the department of tenants of the Great House; text, id. ib. i, p. 218 [2]. Iny , Director of the dining hall, and wife Khenut ; text, id. ib. i, p. 225 [56]. Iny(?) (perhaps same as last) and Ikri, Scribe of the Great House;

¹ Dated by Quibell to Middle Kingdom.

² Exact position unknown.

³ See Addenda.

text, id. ib. i, p. 226 [62]. Iny, Lector-priest, etc.; text, id. ib. i, p. 226 [61]. Iti , Prophetess of Ḥathor, etc.; GUNN MSS. xiv. 49 [1], xviii. 52 [2] (photos.); text, FIRTH and GUNN, op. cit. i, p. 219 [4]. Kagemni , Lector-priest, etc.; id. ib. ii, pl. 11 [2]; i, p. 222 [35]. Kagem . . . ; text, id. ib. i, p. 223 [38]. Khemeny ; text, id. ib. i, p. 222 [28], cf. fig. 93. Khui ; text, id. ib. i, p. 221 [26]. Khui, Lector-priest; text, id. ib. i, p. 221 [27]. Meri (and variations), four; one, id. ib. ii, pl. 11 [5, 7]; i, p. 220 [16]; texts of others, i, p. 220 [13-15]. Meru , Sole companion; text, id. ib. i, p. 220 [17]. Mestni , Royal acquaintance (woman); id. ib. ii, pl. 11 [4]; i, p. 220 [18]. Metety , Lector-priest; text, id. ib. i, p. 220 [19]. Neferirtnes ; text, id. ib. i, p. 221 [21]. Nensia (?); text, id. ib. i, p. 221 [23]. Nensi . . . ; text, id. ib. i, p. 223 [37]. Nikhet , *ka*-servant; text, id. ib. i, p. 222 [29]. Nisokari , Noble of the King; text, id. ib. i, p. 222 [30]. Nofru , Inspector of the Great House, etc.; text, id. ib. i, p. 221 [22]. Sabnes , Overseer of the store-room, and Semut (woman); id. ib. ii, pl. 11 [3]; i, p. 222 [31]. Sebiut (woman); text, id. ib. i, p. 222 [32], cf. fig. 92. Sebkhōtp Iri , Overseer of the sail(?), and Methut(?) (?), Prophetess of Ḥathor, etc.; id. ib. ii, pl. 11 [1]; i, p. 224 [50]. Sekhmet-ankhi (?) (?); text, id. ib. i, p. 225 [57]. Senac. . . (?) (?), Steward; text, id. ib. i, p. 222 [33]. Senezem and Nebt , Prophetess of Ḥathor, etc.; text, id. ib. i, p. 226 [63]. Serefka ; text, id. ib. i, p. 222 [34]. Shafef and Seshemnūfer ; id. ib. ii, pl. 11 [10]; i, p. 225 [55]. Shedy-ptah , Overseer of linen (*sšrw*); id. ib. ii, pl. 11 [9]; i, p. 225 [54]. Teti-haishtef ; text, id. ib. i, p. 223 [36]. Uzai , Noble of the King, two; texts, id. ib. i, pp. 219-20 [11, 12]. Wethesu-khet(?), Royal acquaintance (woman); text, id. ib. i, p. 219 [10].

Names lost or incomplete; one, id. ib. ii, pl. 11 [8]; i, p. 223 [42]; texts of others, i, pp. 223-4, 225-6 [39-41, 43-6, 58-60], cf. figs. 91, 95.

Obelisks.

Two, Siahor , Hereditary prince, King's son of his body, in Cairo Mus. CG 17007-8. KUENTZ, *Obélisques (Cat. Caire)*, pl. v, pp. 14-15. Texts, FIRTH and GUNN, *Teti Pyr. Cem.* i, p. 216 [2, 3].

Obelisk(?), Pepi , Inspector of officials (*srw*). Text, id. ib. i, p. 216 [4].

Other finds.

Planks from canopic-box of Ipi , Lector-priest, etc. Text, FIRTH and GUNN, *Teti Pyr. Cem.* i, p. 268 [5].

Head-rest of Ipiemsaf , alabaster. Text, id. ib. i, p. 270 [5].

Head-rest with remains of text, alabaster. Id. ib. ii, pl. 14 [6]; i, pp. 46 [45, 9], 270 [4, B] (text).

(b) MIDDLE KINGDOM

Mastaba of the Sekwaskhet family. Early Middle Kingdom.

Map LII. Plan LVII.



POSENER, *Princes et pays d'Asie et de Nubie*, pp. 15-17. View, id. ib. fig. 2 facing p. 16; GUNN MSS. xiv. 31 (photos.).

Chapel.

Five false-doors, each with offering-table, in Cairo Mus. JE 55618.

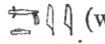
(1) (a) False-door of Sekwaskhet , (b) offering-list, deceased at table, and man offering goose to deceased, (c) unguent-jars, weapons, jewelry, man overthrowing bull, and man offering goose to deceased.

(2) (a) Double false-door, Ni'ankh-ḥor  and Shedy  (woman), (b) offering-list, Ni'ankh-ḥor at table, and offering-bringers below, (c) unguent-jars, weapons, jewelry, Shedy smelling unguent-jar and another woman with mirror.

(3) (a) Double false-door, Sekwaskhet-ṛa  and Mutemsas  (woman), (b) and (c) similar to (2) (b) and (c).

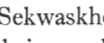
(4) (a) Double false-door of Sekwaskhet-ḥerib  and Sekwaskhet-nekhen , (b) offering-list, Sekwaskhet-ḥerib at table, and offering-bringers below, (c) unguent-jars, jewelry, weapons, and Sekwaskhet (unspecified) at bottom.

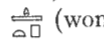
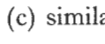
(5) (a) Double false-door of Mery  and Ḥetep  (woman), (b) and (c) similar to (2) (b) and (c), with Ḥetep smelling lotus.

(1)–(5) Id. ib. xiv. 32–8, 39 [1, 2] (photos.); Notebook, 10, Nos. 50, 52–3; 11, Nos. 91–6; 12, Nos. 97–9, cf. p. 17; 27, Nos. 5–8. See POSENER, op. cit. p. 16; *Descr. somm.* No. 6197.

Finds

Clay statuettes with execration-texts, late Dyn. XII. Twelve, some in coffins, in Cairo Mus. JE 70221; see POSENER, op. cit. pp. 15, 17; id. in *Chron. d'Ég.* xiv (1939), pp. 41–2. Others, in Brussels, Mus. Roy. E.7440–94, 7607–14, with some unnumbered; texts, id. *Princes et pays d'Asie et de Nubie*, passim (with E.7440, 7442, 7457, 7460, 7494 on frontispiece and pls. i–iii); E.7440, 7460, 7494, VAN DE WALLE in *Bull. Mus. Roy.* 3 Sér. xii (1940), pp. 74–80 with figs. 2, 3; E.7440, POSENER, SAUNERON and YOYOTTE, *Dict. civ.* fig. on p. 158; E.7442, CAPART and POSENER in *Comptes rendus* (1939), pp. 66–74 with fig.; PRITCHARD, *Anc. Near East*, fig. 593; GRAY, *The Canaanites*, pl. 2, p. 30; SAUNERON, *Les prêtres de l'ancienne Égypte*, fig. on p. 149; NOTH in THOMAS, *Archaeology and Old Testament Study*, pl. i; YADIN, *Hazor*, fig. on p. 14. Ten, formerly in Brussels, now in Tel Aviv, Museum Haaretz; ČERNÝ MSS. 2.195–213 (photos.). Twelve, formerly in Brussels, now in Leyden Mus. F. 1941/8.1–12; F.E.R.E. photos. 22544, 22599, 22500, 22502, 22505, 22510, 22512, 22521, 22542, 22631, 22636, 22642. Two, in coffin, GUNN MSS. xiv. 40 [3] (photo.). Transcriptions of some, GUNN Notebook, 29.

S 2757. USERMUT  and INPUEMḤĒT  INPU . Early Middle Kingdom.

Burial chamber. Finds in Cairo Museum.

QUIBELL and HAYTER, *Teti Pyramid, North Side*, pp. 11–15; section, fig. on p. 12; views, pl. 21 [1, 2].

Funerary equipment of Usermut.

Inner and outer wooden rectangular coffins, Temp. Nos. 11.11.20.8 and 18.1.27.2; id. ib. pl. 21 [3], p. 12; coffin-texts, DE BUCK, *Coffin Texts*, iii, v, vi, Sq 11–12 C. Canopic-box, Temp. No. 2.3.15.2; text, QUIBELL and HAYTER, op. cit. p. 13 [bottom].

Funerary equipment of Inpuemhêt.

Wooden rectangular coffin, Temp. No. 18.1.27.3; CAIRO, CENTRE OF DOCUMENTATION photos. S.A., 2596, 2601-9; coffin-texts, DE BUCK, op. cit. iii, vi, vii, Sq 10 C; see QUIBELL and HAYTER, op. cit. p. 14. Canopic-box, wood, Temp. No. 14.3.15.11; id. ib. pl. 21 [4], p. 15 (texts).

Wooden models.

Papyrus craft, with men setting sail, JE 46767, and with sail furled and rowers, JE 46768; id. ib. pl. 22, pp. 14, 39; see BREASTED (Jr.), *Eg. Servant Statues*, pp. 77 [B, 1], 75 [A, 1]. Boats, with men setting sail, JE 45318, and with sail furled and rowers, JE 46766; QUIBELL and HAYTER, op. cit. pl. 23, pp. 13, 39-40. Granary, JE 45320; id. ib. pl. 25 [1], pp. 14, 41; SAMEH, *Daily Life*, fig. on p. 38 [right]. Craftsmen, JE 45319; QUIBELL and HAYTER, op. cit. pl. 24 [2], pp. 40-1; see BREASTED (Jr.), op. cit. p. 51 [Type 3, 2]. Spinners, JE 45321; QUIBELL and HAYTER, op. cit. pl. 26 [1], pp. 15, 42-3 with fig.; see BREASTED (Jr.), op. cit. p. 53 [4]. Brewers and butchers, JE 45496; QUIBELL and HAYTER, op. cit. pl. 24 [1], pp. 13, 40. Rope-makers, JE 46765; id. ib. pl. 25 [2], pp. 14, 41-2; see BREASTED (Jr.), op. cit. p. 55 [2]. Two female offering-bringers, inscribed for Inpuemhêt, JE 46771-2, and two male statuettes, JE 46769-70; QUIBELL and HAYTER, op. cit. pl. 26 [2], pp. 14, 15, 43; one offering-bringer, see BREASTED (Jr.), op. cit. p. 62 [7].

ḤETEP , Inspector of prophets of the Pyramid of Teti, etc. Temp. Amenemhêt I or later.

Map LII. Plan LIV.

Mother(?), Ikerhathor .

FIRTH and GUNN, *Teti Pyr. Cem.* i, pp. 61-4, 273-9; plans and section, figs. 71, 72 [bottom]; view, id. ib. ii, pl. 40 [A].

Blocks. Id. ib. ii, pls. 20 [A, B], 78 [2]; i, pp. 275-6 [1-8]; GUNN MSS. xviii. 6 (photos.).

Two faience and one alabaster plaque with hieratic text in ink, from foundation deposit. FIRTH and GUNN, op. cit. i, p. 277 with fig. 103, cf. p. 64 [top].

Pillared Court.

(1) Deceased with seven men. Remains of texts, id. ib. i, pp. 274-5 [1].

(2)-(4) Pillars. Remains of texts, id. ib. i, p. 275 [3, 4].

Hall.

(5) and (6) Jambs of doorway. Remains of name and titles, id. ib. i, p. 275 [2].

(7) Bottom of boating scene. Remains of text, id. ib. i, p. 275 [5].

Stature-chambers.

(8) Lower parts of two men carrying haunches. Texts, id. ib. i, p. 275 [6].

(9) and (10) Block-statues of deceased, granite and limestone, in Cairo Mus. JE 48858, 48857.

Id. ib. ii, pls. 40 [C, D], 41 [A, B], cf. i, pp. 62, 277-8; MÜLLER (H. W.), *Ein Kopf von einem frühen Würfelhocker* [etc.] in *Festgabe für Dr. Walter Will* (1966), Taf. vii, viii, pp. 125-7, 136-40 (as diorite instead of granite); SENK in *Ä.Z.* 79 (1954), Taf. xvi [1, 2], pp. 153-5; id. in *Forschungen und Fortschritte*, 33 (1959), Abb. 1, 2, p. 237; VANDERSLEYEN, *Das Alte Ägypten*, Abb. 155; see *Descr. somm.* Nos. 6012, 6011. JE 48858, HAMANN, *Ag.*

Kunst, Abb. 183; ALDRED, *M.K. Art*, pl. 36 (dated temp. Amenemhēt II); WOLF, *Kunst*, Abb. 282; DAUMAS, *Civ. de l'Ég.* pl. 48; WESTENDORF, *Das Alte Ägypten*, fig. on p. 80; MICHALOWSKI, *Art*, fig. 322; DONADONI, *Egyptian Museum Cairo*, pl. on p. 72; *Great Museums*, pl. 45; MÜLLER, *Äg. Kunst*, Abb. 84; id. in *Encyclopedia of World Art*, iv, pl. 354 [lower left]. JE 48857, HORNE MANN, *Types*, ii, pl. 494.

Burial Chamber.

Fragments of sarcophagus. FIRTH and GUNN, op. cit. ii, pls. 81-2, cf. i, p. 279.

IḤY , Overseer of the royal stalls at Lisht, Inspector of the Pyramids of Teti and Amenemhēt I, etc. Dyn. XII.

Map LII. Plan LIV.

Mother, Sit-shenzet  (also .

FIRTH and GUNN, *Teti Pyr. Cem.* i, pp. 64-5, 280-8; plans and section, figs. 72 [middle], 73; view, ii, pl. 16 [B]; GUNN MSS. xviii. 7 (photo.).

Inner Hall.

(1) [1st ed. 1, 2] Doorway. (a) and (b) Remains of names and titles; (c) three registers of offering-bringers.

(a) FIRTH and GUNN, op. cit. ii, pl. 85 [6], cf. i, p. 282 [1] (with text of (b)); GUNN MSS. xviii. 8 [1] (photo.). (c) Id. ib. 8 [2, 3] (photo.); texts, FIRTH and GUNN, op. cit. i, pp. 282-3 [2].

(2) [1st ed. 3-4] Deceased at table, with mother squatting, and offering-bringers.

Id. ib. ii, pl. 54, cf. i, pp. 283-4 [4].

(3) [1st ed. 6-7] Similar to (2), with three registers of priests and offering-bringers in front and one of offering-bringers below.

Deceased and mother and some offering-bringers, id. ib. ii, pl. 39. Texts, id. ib. i, pp. 284-5 [5].

(4) [1st ed. 5] False-door.

Id. ib. ii, pl. 83, cf. i, p. 283 [3]; GUNN MSS. xviii. 9 [1] (photo.).

Burial Chamber. Painted decoration.

Texts and friezes of objects. Views of west and south walls, id. ib. xviii. 5 [2, 3] (photos.), cf. 5A (copies of some texts). Texts, FIRTH and GUNN, op. cit. i, pp. 286-8.

Finds

Two block-statues of deceased, fragments. Texts, id. ib. ii, pls. 84, 85 [1-5], cf. i, pp. 285-6.



MIDDLE KINGDOM FINDS

Fragment of statue-base of Kagemni . Text, FIRTH and GUNN, *Teti Pyr. Cem.* i, p. 289 [2]; GUNN Notebook, 11, No. 87.

Lintel-fragment with beginning of address. Text, FIRTH and GUNN, op. cit. i, p. 289 [4].

Block with remains of autobiographical text, perhaps Middle Kingdom. Id. ib. ii, pl. 85 [7]; i, p. 289 [1].

Side-piece of Ipi , Scribe, early Middle Kingdom, found north of tomb of Mereruka. SAAD in *Ann. Serv.* xliii (1943), pl. xxxv, pp. 450-1.

Khenuhotp , *imy-st-ε* of the Temple of Ptaḥ-Sokari. Fragment of stela, with [son Senusert , *warb-priest*] before deceased, GUNN Notebooks, 7, No. 48, and 10, No. 37. Fragment of offering-table; FIRTH and GUNN, *op. cit.* ii, pl. 11 [11]; i, p. 289 [3].

(c) 2ND INT. PERIOD



Intrusive burial in the Mortuary Temple of Iput I

Rectangular coffin of 'Abed , wood, in Cairo Mus. CG 28108. LACAU, *Sarcophages*, ii, pl. xix [1, 2], pp. 86-7; SCHMIDT, *Levende og Døde*, figs. 443-4 (from LACAU). See MASPERO, *Guide*, p. 308 [3106]; LORET in *Bull. Inst. Ég.* iii Sér. 10 (1899), p. 88; MÜLLER (W. M.) in *O.L.Z.* 5 (1902), cols. 174-5.

Dagger of Neḥemen , Henchman of his Lord, with cartouches of Nebkhepeshrēc Apophis III, and hunting scene, bronze, from coffin, in Cairo Mus. CG 52768. DARESSY in *Ann. Serv.* vii (1906), pl. at end [1, 2], pp. 118-19; JÉQUIER, *Hist. civ.* fig. 160; WAINWRIGHT in *University of Liverpool. Annals of Archaeology and Anthropology*, vi (1914), pl. xiv [3], p. 51; MEYER, *Fremdvölker*, 241; PETRIE in *Anc. Eg.* (1930), fig. on p. 98 [9] (from DARESSY); ROSS, *The Art of Egypt*, pl. on p. 184 [1]; LABIB, *Die Herrschaft der Hyksos in Ägypten und ihr Sturz*, Taf. 2, 3, p. 28; MAZAR, *Views*, i, pl. 113 [right]. Text, VERNIER, *Bijoux et orfèvreries (Cat. Caïre)*, p. 260; MÜLLER (W. M.) in *O.L.Z.* 5 (1902), cols. 175-6; HELCK, *Historisch-biographische Texte*, p. 55 [75]. See LORET in *Bull. Inst. Ég.* iii Sér. 10 (1899), pp. 88, 97-8 [2]; SAYCE in *P.S.B.A.* xxiv (1902), p. 86 [bottom]; MASPERO, *Guide*, p. 427 [4012]; LACAU, *Sarcophages*, ii, p. 86 note 1.

(d) NEW KINGDOM

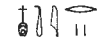
No. 2 (of Loret). AMENEMÖNET , Overseer of craftsmen, and Head of goldworkers, of the Lord of the Two Lands. End of Dyn. XVIII.

Parents, Kharuef  and Nefertere  Inu . Wives, Tahesy , Songstress of Amūn, etc., and Nefertere.

LORET in *Bull. Inst. Ég.* iii Sér. 10 (1899), p. 95, cf. plan facing p. 100; LÖHR in *Pantheon*, xxviii (1970), pp. 467-74, with plan (from LORET) and section, Abb. 5.

In Munich, Staatliche Sammlung Ägyptischer Kunst.

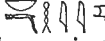
Block, *recto*, male mourners before tomb, and below, address to gods of Memphis by son Ptaḥmosi, Scribe of the Treasury, *verso*, left, son Nebmehyt , Goldworker, and wife kneeling in tree-goddess scene, with *bas* drinking, and below, priest with address to gods, right, deceased and wife Nefertere at table, Gl. 298. VON BISSING in *Acta Orientalia*, vi (1928), Taf. i, ii, pp. 1-18; id. in *Münchner Jahrb. N.F.* i (1924), pp. 207-11 with figs., cf. pp. 221-4; *Äg. Sammlung* (1966), Abb. 50-1; *Staatl. Sammlung* (1972), pls. 39, 40, pp. 75-6; (1976), pp. 109-12 with figs. (incomplete); LÖHR, *op. cit.* Abb. 1, 2; *Nofretete, Echnaton. Ausstellung . . . München*, 17. Januar-21. März 1976, Nos. 88-9; mourners before tomb, GILBERT, *Méditerranée antique* [etc.], fig. 73; mourners, RADWAN in *Mitt. Kairo*, 30 (1974), Taf. 18 [a], pp. 118-20 [1]; tree-goddess scene, KEIMER in *Ann. Serv.* xxix (1929), pl. ii, p. 84; MÜLLER, *Äg. Kunst*, Abb. 138; see WOLTERS, *Führer* (1928), p. 14 [77].

In Cairo Museum.

Stela, dedicated by sons Ptaḥmosi and Amenemḥab, Head of goldworkers, Temp. No. 10.6.24.8. FORMAN (W. and B.) and VILÍMKOVÁ, *Eg. Art*, pls. 107, 109; OTTO and HIRMER,

Osiris und Amun, pl. 6 (as 11732); LÖHR, op. cit. Abb. 3; lower part, GARDINER MSS. photo. 28.317A; see VON BISSING in *Acta Orientalia*, vi (1928), pp. 16–17.

Pyramidion, JE 41665. See MASPERO, *Guide*, pp. 193–4 [758]; BRUYÈRE, *Rapport sur les fouilles de Deir el Médineh (1923–4)*, p. 13 [middle].

Blocks. (a)–(f) Temp. No. 17.6.25.1, (a) five female relatives and text, (b) two registers of female and male offering-bringers, (c) offering-bringers approaching offerings, with remains of cattle-counting above, (d) two male and four female offering-bringers, (e) remains of 20 columns of text and man on right, (f) priest censuring, and remains of shrine with squatting divinities and steps above. (g) Temp. No. 5.7.24.11, four male offering-bringers, two female mourners, and priest censuring, with remains of cattle-counting before deceased and wife seated above. (h) Temp. No. 5.7.24.15, deceased with wife and two sons before Sekhmet in shrine, and offerings, and children as offering-bringers below.

(a) LÖHR, op. cit. Abb. 4. (f) Id. ib. Abb. 6. (g) Offering-bringer with yoke and mourners, WERBROUCK, *Pleureuses*, pl. xxxiii, p. 83; offering-bringer carrying crane, and upper part of mourner on left, FORMAN (W. and B.) and VILÍMKOVÁ, *Eg. Art*, pls. 103, 110; upper part of mourner, MAZAR, *Views*, iii, pl. 128; WENIG, *Die Frau*, pl. 86. (h) *Le Règne du Soleil. Akhnaton et Néfertiti*. Exposition . . . Bruxelles, 17 janvier–16 mars 1975, No. 70; *Echnaton, Nofretete, Tutanchamun*. Ausstellung . . . Wien, 23. April–29. Juni 1975, No. 70; *Solens rike. Aknaton, Nefertiti, Tut-ank-Amon*. Utstillingen . . . Oslo, 16. juli–16. september 1975, No. 70 with pl. 67; *Echnaton och Nefertiti*. Utställning . . . Stockholm, 16 oktober–7 december 1975, No. 70 with pl. 67; *Nofretete, Echnaton*. Ausstellung . . . München, 17. Januar–21. März 1976, No. 70; *Nofretete, Echnaton*. Ausstellung . . . Berlin, 10. April–16. Juni 1976, No. 70; *Echnaton, Nofretete, Tutanchamun*. Ausstellung . . . Hildesheim, 15. Juli–26. September 1976, No. 70; upper part of deceased and wife and Sekhmet, FORMAN (W. and B.) and VILÍMKOVÁ, op. cit. pl. 105.

Double-statue, deceased and wife Nefertete seated, Temp. No. 8.6.24.10. HORNEMANN, *Types*, v, pl. 1215; see LORET, op. cit. p. 95.

No. 4 (of Loret). THAY , Overseer of the horses of the Lord of the Two Lands, etc. End of Dyn. XVIII.



LORET in *Bull. Inst. Ég.* iii Sér. 10 (1899), p. 95, cf. plan facing p. 100.

Stela, in Cairo Mus. JE 34542.

Statue, ebony, in Cairo Mus. JE 33255. LANGE (K.), *König Echnaton und die Amarna-Zeit*, pls. 48–9; id. *Äg. Kunst*, pl. 72; id. and HIRMER, *Ägypten. Architektur (1967)*, pls. 204–5; STEINDORFF and SEELE, *When Egypt Ruled the East*, fig. 64; HAMANN, *Äg. Kunst*, Abb. 274; WOLF, *Kunst*, Abb. 562; HORNEMANN, *Types*, i, pl. 164; *I.L.N.* July 4, 1936, figs. on p. 27; *Descr. somm.* No. 6257 with pl. facing p. 163; upper part, FORMAN (W. and B.) and VILÍMKOVÁ, *Eg. Art*, pl. 66; DRIOTON, *Temples et Trésors de l'Égypte*, pl. 26; see LORET, op. cit. pp. 99–100 [6].

No. 5 (of Loret). MOSI , Scribe of the Treasury of Ptaḥ. Temp. Ramesses II.

Plan LVII.

Parents, Huy , Scribe of the Treasury of Ptaḥ, and Nubnefert . Wife, Mutnefert , Songstress of Bubastis Mistress of 'Ankhtau.

GABALLA, *The Memphite Tomb Chapel of Mose*, in preparation; LORET in *Bull. Inst. Ég.* iii Sér. 10 (1899), pp. 95–6, cf. plan facing p. 100.

Part reconstructed in Cairo Mus. Doorway at (3), Temp. No. 25.1.15.7, rest 17.6.25.5.

(1) Judgement-scene, and deceased and wife adoring. (2) Fields of Iaru in bottom register. (3) Doorway. (a) and (b) Deceased adoring, (c)–(f) titles.

(4) Deceased and wife offering head of oryx to bark of Sokari in bottom register.

GABALLA in *Orientalia*, N.S. 41 (1972), pls. iv, v, pp. 178–9.

(5) Two registers, I, deceased and wife before god, and deceased before Thoth, II, deceased and wife adoring Thoth, and deceased adoring Thoth. (6) Two registers, I, double-scene, deceased before a goddess, II, double-scene, deceased adoring Horus, and adoring Anubis. (7) Registers, I, lower part of deceased and wife before a god and goddess, II, deceased adoring bull and seven cows with genii and oars. Text mentioning father below. (8) Osiride statue (uninscribed). (9) Remains of titles and deceased adoring.

Blocks included in reconstruction by Anthes.

ANTHES in *Mitt. Kairo*, 9 (1940), pp. 93–118, cf. 118–19, with plan on Abb. 1, 2 (latter from LORET).

Outer Hall.

(10) Deceased censes before Amūn of Neshi as crio-sphinx, and remains of offering-scenes before gods above.

Id. ib. Taf. 18 [b], pp. 109–10 [1].

(11) and (12) Blocks with text on lawsuit concerning land presented to Mosis's ancestor Neshi , Overseer of boats, by Amosis, with one document dated year 58 or 59 of Haremhab, in Cairo Mus. Temp. No. 17.5.25.8.

GARDINER MSS. photo. 28.1079–87. Text, LORET in *Ä.Z.* xxxix (1901), pp. 5–10, cf. 1–5; GARDINER, *The Inscription of Mes* in SETHE, *Untersuchungen* [etc.], iv, pp. 127–40, cf. 89–126; see MORET in *Ä.Z.* xxxix (1901), pp. 11–39. Additional block, ANTHES, op. cit. pp. 110–11 [2] with fig., cf. p. 114; text, GUNN MSS. xx. 11, with plan (all by Quibell). Neshi, see POSENER in *Rev. d'Ég.* xvi (1964), pp. 213–14. See MASPERO, *Guide*, p. 169 [598].

Pillars.

Seven blocks, *zad*-pillars and deceased adoring, in Sydney Univ. Nicholson Mus. of Antiquities. NICHOLSON, *On some Funereal Hieroglyphic Inscriptions found at Memphis* in *Transactions of the Royal Society of Literature*, 2 Ser. viii (1866), pls. i–iv after p. 230, cf. pp. 308–25 (repr. NICHOLSON, *Aegyptiaca*, pp. 95–112 with pls. i–iv); see REEVE, *Catalogue of the Museum of Antiquities of the Sydney University* (1870), pp. 89–90 [1131–5, 1137]; ANTHES, op. cit. pp. 112–13, 117; GAUTHIER in *Ann. Serv.* xxxv (1935), p. 206.

Inner Hall. In Cairo Mus. Temp. No. 22.5.25.1 unless otherwise stated.

(13) Doorway. (a) Deceased adoring; (b) deceased with scribe's equipment.

(a) Text, ANTHES, op. cit. pp. 104 [b], cf. 103. (b) Name and title, id. ib. p. 104 [c]; id. in *Ä.Z.* 74 (1938), p. 109 [2b].

(14)–(15) Offering-bringers, with deceased before Ptaḥ in shrine above at (15).

See id. in *Mitt. Kairo*, 9 (1940), p. 104 [d, e].

(16) Remains of three registers, I, offering-scenes before divinities, II, relatives at banquet, III, offering-bringers. Only III in Cairo Mus., block from left end of II in Hanover Mus. 1935.200.191.

View after excavation, id. ib. Taf. 18 [a], pp. 104 [g], 105-9.

(17) Bottom register of offering-bringers, with deceased before Ptaḥ-Sokari-Osiris in shrine and Ḥathor above. See id. ib. p. 104 [f].

(18) Deceased and others before jury. Id. ib. Taf. 17, pp. 93-102, 103 [a].

Other blocks.

Three registers, **I**, almost completely lost, **II**, female mourners, and coffin in bark on sledge dragged by oxen, **III**, statue of deceased in shrine, mourners and remains of two boats, in Cairo Mus. Temp. No. 17.5.25.1. WERBROUCK, *Pleureuses*, fig. 50, pp. 83-4 (called Ptaḥmosi); omitting statue, LÜDDECKENS in *Mitt. Kairo*, 11 (1943), Abb. 50, pp. 134-9 [64-6].

Blocks, deceased and wife before gods, etc. GUNN Notebook, 6, Nos. 25-31 (lower part of No. 29 in Boston Mus. 1974.315; 98th Annual Report 1973-4, fig. on p. 9 [middle right], cf. p. 14); 7, Nos. 32-5; 8, Nos. 64, 66.

S 2730 (and probably 2736). IPUIA , Overseer of a workshop, and Head of goldworkers, of the Lord of the Two Lands. Late Dyn. XVIII.

Plan LVII.

Wife, Nefertere .

Chapel. Numbers are those of Cairo Museum.

QUIBELL and HAYTER, *Teti Pyramid, North Side*, pp. 10-11, with plan, on pl. 2.

Loose blocks. Registers of industries, including statue of Bes on left, and on right, **I**, sculptors, **II**, carpenters, **III-IV**, metal-workers, including making metal statue of king and harness(?), Temp. No. 17.6.24.13; id. ib. pl. 13, p. 36; CURTO, *L'Arte militare presso gli Antichi Egizi*, fig. on 21st p.; GRIFFITH INST. photo. 357; wheelwrights in **II**, and metal-workers and making statue in **III**, SAMEH, *Daily Life*, figs. on pp. 53 [upper], 57 [upper]. Various, QUIBELL and HAYTER, op. cit. pl. 14, p. 36.

Hall. View, id. ib. pl. 8.

Block with wife and mourners before mummy, Temp. No. 21.6.24.12. Id. ib. pl. 11 [upper], p. 35; upper part of one mourner, RADWAN in *Mitt. Kairo*, 30 (1974), Taf. 18 [c], Abb. 9, p. 121 [1].

(1) Stela, JE 44722.

QUIBELL and HAYTER, op. cit. pl. 9, pp. 32-3. See MASPERO, *Guide*, pp. 159-60 [545].

(2) Stela, Temp. No. 27.3.25.17.

QUIBELL and HAYTER, op. cit. pl. 11 [lower], p. 35; LEIBOVITCH, *Anc. Eg.* fig. 86, p. 115; OTTO and HIRMER, *Osiris und Amun*, pl. 7.

(3) Two blocks, scenes before canopic-jars and coffins, son Ḥuy  with wife censuring to statue of deceased, and garden with trees and pond with boats, Temp. No. 21.6.24.16.

QUIBELL and HAYTER, op. cit. pl. 10, pp. 33-5 with fig.; GRIFFITH INST. photo. on 358. Two top registers with trees and people, BORCHARDT in *A.Z.* 64 (1929), Taf. i [3], p. 14 with note 6. Boy gathering dates, SAMEH, *Daily Life*, fig. on p. 115 [left].

Room west of Hall.

(4) Men leading horses, JE 44924.

QUIBELL and HAYTER, op. cit. pl. 12 [upper], p. 35; GARDINER MSS. photo. 28.441A. See *Descr. somm.* No. 655.

(5) Archers shooting at target, chariot, etc.
 QUIBELL and HAYTER, op. cit. pl. 12 [lower], p. 36.

Finds

Wooden statuette of naked boy wearing large earrings, with name Iy $\text{𓆎} \text{𓆎} \text{𓆎}$ on base, late Dyn. XVIII, found in coffin near main shaft, JE 44884. Id. ib. pl. 20 [1-3], pp. 37-8.

S 2735 [LS 12, incorrectly placed]. HUY $\text{𓆎} \text{𓆎} \text{𓆎}$, Scribe of the troops of the Lord of the Two Lands, etc. End of Dyn. XVIII.

Wife, Mery(t)-sekhmet $\text{𓆎} \text{𓆎} \text{𓆎}$, Songstress of Amün of Peru-nüfer.

WENIG in *Festschrift zum 150jährigen Bestehen des Berliner Ägyptischen Museums* (1974), pp. 239-45. Position, QUIBELL and HAYTER, *Teti Pyramid, North Side*, on pl. 2.

Block, [deceased] and wife seated, and deceased kneeling in adoration before Atum. Id. ib. pl. 19 [upper], p. 37; see WENIG, op. cit. pp. 240-1 [2], cf. Abb. 2 (from QUIBELL and HAYTER).

Block, deceased spearing crocodiles, with spell against crocodiles. Id. ib. Taf. 32 [c], pp. 241-2 [3]; GUNN MSS. xix. 13 [1] (photo.).

Jamb-fragment, deceased adoring, in Berlin (East) Mus. 2087. WENIG, op. cit. Taf. 32 [a, b], pp. 239-40 [1] with Abb. 1; L. D. *Text*, i, fig. on p. 161; text, *Aeg. Inschr.* ii, p. 118; see *Ausf. Verz.* p. 150.

Fragments of statue-group, sandstone, from S 2721. Texts, GUNN Notebook, 8, No. 67; see QUIBELL and HAYTER, op. cit. p. 37; WENIG, op. cit. p. 242 [4].

LS 8. MERYRĒ $\text{𓆎} \text{𓆎} \text{𓆎}$, Head of custodians. Dyn. XIX.

Blocks, deceased before three gods. L. D. *Text*, i, p. 144.

MAḤU $\text{𓆎} \text{𓆎} \text{𓆎}$, Custodian of the Treasury. Ramesside.

Found by Loret in 1898-9. Position unknown.

Offering-table, in Cairo Mus. CG 23094. KAMAL, *Tables d'offrandes (Cat. Caire)*, pl. xx, p. 81.

Block, Kings Zesernub $\text{𓆎} \text{𓆎} \text{𓆎}$ (Neterikhet), Teti (probably Sekhemkhet) and Userkaf squatting before hawk-headed Rĕ-Ḥarakhti and a god, in Cairo Mus. JE 33258. GAUTHIER in *B.I.F.A.O.* v (1906), pp. 41-2 with fig.; WILDUNG, *Die Rolle äg. Könige*, i, Abb. v [2], pp. 74-6 [Dok. xvi. 90], 97 [Dok. xvii. 60]. See JÉQUIER in *Rec. Trav.* xxx (1908), p. 45.



NEW KINGDOM FINDS





Statues.



Nude girl with basket on head, ebony, probably mirror-handle, in Cairo Mus. JE 47789. FIRTH and GUNN, *Teti Pyr. Cem.* ii, pl. 45 [E]; i, p. 78 [80, v].

Crocodile, dedicated to Sobk by Amenemwia $\text{𓆎} \text{𓆎} \text{𓆎}$, Head of bowmen, damaged, from S 2720, in Cairo Mus. JE 45103. See QUIBELL and HAYTER, *Teti Pyramid, North Side*, p. 11.



Stelae.

Amenma , Custodian of the palace (*pr*) of His Majesty, and wife Tuy , Dyn. XVIII, in Berlin (East) Mus. 7320. L. *D. Text*, i, fig. on p. 156, cf. p. 154 and section on p. 146 [lower, e]. Text, *Aeg. Inschr.* ii, pp. 107-8. Names and titles of deceased and wife, LIEBLEIN, *Dict.* No. 746. See *Ausf. Verz.* p. 158; *Führer* (1961), p. 58.

Nebꜥan(en)su , Custodian of the 'Splendour of the Aten', and wife Henutnefert  adoring Osiris, and children before Senu  and wife Ipu  seated, temp. Amenophis III, in Cairo Mus. CG 34055. LACAU, *Stèles*, pl. xxxiii, pp. 98-9. Names, LEGRAIN, *Répertoire*, No. 273.

Nefersekheru , *wꜥb*-priest, Craftsman of Ptaḥ, dedicated by wife Maḥu , Ramesside. BAKRY in *Ann. Serv.* lv (1958), pp. 67-71 with pl.

Blocks, etc.

Merya , Merchant, and wife Sitti , late Dyn. XVIII or Ramesside, from S 2727, in Cairo Mus. (a) Two scenes, deceased and wife seated, with family and musicians, JE 44926; QUIBELL and HAYTER, *Teti Pyramid, North Side*, pl. 15, pp. 11, 36; HICKMANN in *Ann. Serv.* xlix (1949), fig. 12, p. 437; id. *45 Siècles*, pl. lxxv [A]; girl with cup from top register, *Encycl. phot. Caire*, pl. 151; head of girl lutist, SCHOTT, *Altägyptische Liebeslieder*, pl. 20 facing p. 177. (b) Deceased adoring Ptaḥ-Sokari, JE 44928; QUIBELL and HAYTER, op. cit. pl. 17 [left], p. 37. (c) Wife adoring Ḥaṥhor, Temp. No. 3.7.24.2; id. ib. pl. 17 [right], p. 37; wife, FORMAN (W. and B.) and VILÍMKOVÁ, *Eg. Art*, pl. 79; *Egyptian Mythology*, fig. on p. 8.

Blocks, late Dyn. XVIII or Ramesside, found with last. In Cairo Mus., (a) two registers of offering-bringers, JE 44925; QUIBELL and HAYTER, op. cit. pl. 16, p. 36; (b) Osiris and Isis, JE 44929; pl. 18 [upper left], p. 37; (c) upper part of purification scene, JE 44930; pl. 18 [upper right], p. 37. Others, including Osiris and Maꜥet; id. ib. pl. 18 [lower], 19 [lower], p. 37.

Block and jamb of Mernekhu , from S 2720. See id. ib. p. 11.

VariouS.

Offering-table of Minnakht , Royal scribe, sandstone, Dyn. XVIII, in Cairo Mus. CG 23079. KAMAL, *Tables d'offrandes (Cat. Caire)*, pl. xvii, p. 66.



Ushabti-box of Miniry (?) , wood, early Dyn. XIX. FIRTH and GUNN, *Teti Pyr. Cem.* i, fig. 83, p. 79.

Cylindrical box with animals and plants, wood, in Cairo Mus. CG 44706 (JE 32744). BORCHARDT in *Studies Presented to F. Ll. Griffith*, pl. 26 [a], pp. 257-8.

Scribe's palette with hieratic text, and wooden plaster-covered writing board with part of the Prophecies of Neferti in hieratic on both sides, middle Dyn. XVIII, in Cairo Mus. CG 69021, 25224. Text of CG 25224, DARESSY, *Ostraca (Cat. Caire)*, pp. 52-4; GOLÉNISCHEFF, *Les Papyrus hiératiques NoNo. III5, III6A et III6B de l'Ermitage Impérial à St. Pétersbourg*, pl. suppl. d and Ð. See LORET in *Bull. Inst. Ég.* iii Sér. 10 (1899), p. 98 [3].

Cylinder seal of Amenophis I, steatite. FIRTH and GUNN, op. cit. ii, pl. 46 [A, 91]; i, pl. 68 [2, 2].

(e) LATE PERIOD

Stela of Zeamūnefꜥankh, son of Herba(neb)ded  and Tadesmazedeb(?) , Saite. CAIRO, CENTRE OF DOCUMENTATION photo. S.A., 2376. Name, QUIBELL and HAYTER, *Teti Pyramid, North Side*, p. 8.

EAST AND SOUTH-EAST OF THE PYRAMID

(a) MORTUARY TEMPLE AREA

RA^cWĒR  (erased), Chief Justice and Vizier, etc. Probably late Dyn. VI.

Map LI.

Two false-doors. GUNN MSS. xiv. 53-4 and R.1.3, 4, 10 (photos. and tracings); Notebook, 19, pp. 32-8; one, GRINSELL, *Barrow, Pyramid and Tomb*, fig. 60.

Seated headless statue of deceased, and lower part of another, both granite. Texts, GUNN MSS. xv. 8; Notebook, 9, Nos. 1, 2.

Texts of various fragments found nearby, id. ib. 19, pp. 39-42.

SHEMA  (father and son) and IPISENBES  IPI (woman). Dyn. VI or 1st Int. Period.

South of the Temple.

From south: (a) Fragments of side-pieces of Shema (father), with Shema (son) offering goose to [deceased] on the right one. (b) (preliminary sketches) Lower part and fragments of false-door of Shema (son), with deceased and wife and offering-bringers on right side-piece. (c) Lower part and fragments of false-door of Ipi-senbes, with side-pieces (in fragments), left, remains of offering-list and deceased at table, right, butchers and offering-bringers.

(a) Sketch and texts, GUNN Notebook, 12, Nos. 110, 111. (b) Id. MSS. xiv. 61 [2] (photo. *in situ*). Texts of false-door, id. ib. on xv. 35b; Notebook, 9, No. 11; of side-piece, 12, No. 108.

(c) False-door, id. MSS. xiv. 61 [1] (photo.). Texts (including side-pieces), id. Notebook, 12, Nos. 106-7.

LS 13. NAME UNKNOWN, Scribe of the royal documents. Probably New Kingdom.

Title, L. D. *Text*, i, p. 161.

ḤEKMA^cETRĒ^c-NEḤEH , First [royal butler] of the Lord of the Two Lands, etc. Dyn. XX.

Above the Temple.

Views and blocks, GUNN MSS. xix. 4-6 (photos.); texts, id. Notebook, 6, No. 21; 8, Nos. 60, 63.

‘AKHPET , Chief lector-priest in the Two Houses of Mummification (*prwy-nfr*), etc. Early Dyn. XIX.

Immediately east of the Temple.

View, LAUER in *Bull. Soc. fr. d'Ég.* No. 47 (Dec. 1966), pl. iv, pp. 20, 32-4; LECLANT in *Orientalia*, n.s. 36 (1967), pl. xxvi [5], p. 189 [top]; 37 (1968), pl. xviii [16], p. 105 [top].

Pillar-fragment, emblem and head of deceased. Id. in *Bull. Soc. fr. d'Ég.* No. 46 (July 1966), pl. iii [A], p. 15; id. in *Orientalia*, n.s. 36 (1967), pl. xxvi [6].

Column-fragment, Anubis seated. Id. ib. n.s. 37 (1968), pl. xviii [17].

Blocks. Deceased and *ba*-bird, LAUER in *Comptes rendus* (1966), pl. iii [b], pp. 467-9; id. *Saqqara*, pl. 153; LECLANT in *Bull. Soc. fr. d'Ég.* No. 46 (July 1966), pl. iii [B], p. 15; id. in *Orientalia*, n.s. 36 (1967), pl. xxviii [11]; adoring Rēc-Ḥarakhti, pl. xxvii [8]; kneeling adoring, pl. xxviii [12]; middle part of deceased, id. ib. n.s. 37 (1968), pl. xix [18]. Monkey, id. ib. n.s. 36 (1967), pl. xxvii [9]. Two registers, I, [deceased seated], with monkey under chair, II, people before Merenptah , Head of bowmen, id. ib. pl. xxvii [10].

Sarcophagus, granite. Id. ib. pl. xxvi [7].

VARIOUS FINDS FROM MORTUARY TEMPLE AREA

Old Kingdom.

Lintel-fragment of a Prophet of the Pyramid of Teti. LAUER and LECLANT, *Le Temple haut du complexe funéraire du roi Tēti*, pl. xxxi [A], fig. 71, p. 83 [61].

Fragment of false-door of an Inspector of prophets of the Pyramid of Teti. Id. ib. pl. xxxi [B], pp. 83-4 [62].

Ramesside.

Huy and Tentamentet (woman), stela, in Cairo Mus. JE 36853.

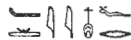
Ḥuynūfer , Scribe of the altar of the Temple of Ptaḥ, faience plaque, in Cairo Mus. JE 39171. QUIBELL, *Saqqara (1906-1907)*, pl. xxxv [4], pp. 5, 79.

Ḳenḥirkhopshef , . . . in the Place of Truth, Butler, lower part of stela; id. ib. pl. xxxvii [1], pp. 4, 80. Block with deceased kneeling; name, GUNN Notebook, 8, No. 61.

Ḳennakht adored by Mentuemwēset, stela, in Cairo Mus. JE 36856.

Khaḥ , Scribe of the Lord of the Two Lands, draughts-board, wood, temp. Sethos I, in Cairo Mus. CG 68001. QUIBELL, *Saqqara (1907-1908)*, pls. lviii [1], lix, pp. 21, 114-15; *Encycl. phot. Caire*, pl. 153. See NEEDLER in *J.E.A.* 39 (1953), p. 74 [16].

Nefer[ḥor] , Overseer of the workshop, fragments of jamb; text, GUNN Notebook, 8, No. 57. Text of another block, id. ib. No. 65.

Raḥmeses-userkhepesh , Fan-bearer on the right of the King, etc., lower part of statue, kneeling with offering-table; QUIBELL, *Saqqara (1906-1907)*, pl. xxxvii [2, 3], pp. 4, 80 (text). Cornice; name and titles, id. ib. p. 4. Block; name and title, GUNN Notebook, 8, No. 59.

Sayempeter , Outline-draughtsman, stela, in Cairo Mus. JE 39140. QUIBELL, *Saqqara (1906-1907)*, pl. xxxvi [5], p. 80.

Set-ḥirwenemef , Chief steward of the Lord of the Two Lands, etc., adoring Ptaḥ and Rēc, column-fragment, temp. Ramesses II. Id. ib. pl. xxxvii [4, 5], p. 81.

Inscribed blocks; GUNN Notebook, 8, Nos. 58, 62; 19, p. 22 [top]. Block with remains of official and Osiris, QUIBELL, *Saqqara (1906-1907)*, pl. xxxvii [6], pp. 4, 81.

Alabaster vase of Ramesses II, in Cairo Mus. JE 40691. Id. ib. (1907-1908), pl. lvii [5], pp. 21, 114.

Late Period and Ptolemaic.

Statuette of priest of Anubis, torso, Late Period. LECLANT in *Orientalia*, n.s. 36 (1967), pl. xxix [13, 14], p. 189 [top].

Sculptor's model, royal head, Ptolemaic, found by Firth near the Subsidiary Pyramid in 1925, in Neuchâtel Mus. Eg. 382.

(b) 'GREEK SERAPEUM' ENCLOSURE AREA

Plan, QUIBELL, *Saqqara* (1905-1906), pls. ii, iii; (1906-1907), plan on p. 20. Views, id. ib. (1905-1906), pls. iv-viii, pp. 18-19.

No. 75 (of Quibell). I P I \square \square , Treasurer of the King of Lower Egypt, etc. Middle Kingdom.

QUIBELL, *Saqqara* (1905-1906), pp. 4-5; view, pl. xxii [1], p. 27.

Burial Chamber. Painted decoration.

Offerings, offering-texts and probably coffin-texts. Id. ib. pl. xxii [2], p. 5.

Canopic-jar. Text, id. ib. p. 5.

EARLY MIDDLE KINGDOM TOMB

Map LI.

QUIBELL, *Saqqara* (1905-1906), pp. 2-3; (1906-1907), pp. 6-15; id. in *Egypt Exploration Fund. Archaeological Report 1906-1907*, pp. 25-6.

North burial chamber. Harshefnakht $\text{𓆎} \text{𓆏} \text{𓆐} \text{𓆑}$ (from canopic-box).

Lower part of statuette of Pepy $\text{𓆎} \text{𓆏} \text{𓆐} \text{𓆑}$, *wab*-priest of the roof, son of Senmut(?) $\text{𓆎} \text{𓆏} \text{𓆐} \text{𓆑}$, seated on ground, basalt, probably New Kingdom and intrusive, in Cairo Mus. JE 39143. Id. *Saqqara* (1906-1907), pl. xi, pp. 7, 73 (as granite); ENGELBACH in *Anc. Eg.* (1932), fig. on p. 13; HORNEMANN, *Types*, ii, pl. 439 (as Old Kingdom).

South burial chamber. Numbers are those of Cairo Museum.

In situ, QUIBELL, *Saqqara* (1906-1907), pls. xii, xiii, p. 74. Texts on model ewer and basin, id. ib. p. 9.

Rectangular wooden coffins of Karenen $\text{𓆎} \text{𓆏} \text{𓆐} \text{𓆑}$, Steward, etc., inner and outer, JE 39053-4. Coffin-texts of outer coffin, LACAU in ib. pp. 24-50; DE BUCK, *Coffin Texts*, i-vii, Sq 6 C; of inner coffin, i, Sq 5 C.

Rectangular wooden coffin of Nefersemdent $\text{𓆎} \text{𓆏} \text{𓆐} \text{𓆑}$ (woman), JE 39114. Interior, QUIBELL, *Saqqara* (1906-1907), pls. xx-xxv. Coffin-texts, LACAU in ib. pp. 24-58 (called JE 39014); DE BUCK, op. cit. i, iii-vii, Sq 3 C.

Head-rests of Nefersemdent and Karenen, JE 39155-6.

Canopic-box of Karenen, JE 39107. Text, QUIBELL, *Saqqara* (1906-1907), p. 10.

Statuettes and models. Wood.

Two male and two female statuettes, JE 39150-3. Id. ib. pl. xiv, pp. 11, 74.

Boats, three in Cairo Mus. JE 39127-8, 39144. Id. ib. pls. xvii [2], xviii [1, 5], pp. 9, 11, 12, 75, 76. One (= pl. xviii [5]), WEIGALL, *Anc. Eg. . . . Art*, 77 [left lower]; CAPART, *L'Art ég.* ii, pl. 269; WESTENDORF, *Das Alte Ägypten*, fig. on p. 73; *Great Museums*, fig. on p. 196 [30]; DAVID, *The Egyptian Kingdoms*, fig. on p. 118.

Kitchens, one in Cairo Mus. Temp. No. 4.3.23.1. QUIBELL, *Saqqara* (1906-1907), pl. xix [1], pp. 8, 11, 76; see BREASTED (Jr.), *Eg. Servant Statues*, p. 46 [upper, 3]; MASPERO, *Guide*, p. 318 [3136].

Brewers, JE 39146. QUIBELL, *Saqqara (1906-1907)*, pl. xix [3], pp. 12, 76; MASPERO, *Égypte*, fig. 166; CHAMPDOR, *Thèbes aux cent portes*, fig. on p. 77 [lower]; SOGA, *The Nile*, fig. on p. 68 [left]; see BREASTED (Jr.), op. cit. p. 34 [3]; MASPERO, *Guide*, pp. 314-15 [3123].

Procession of offering-bringers, JE 39126. QUIBELL, *Saqqara (1906-1907)*, pl. xv, pp. 8, 74; CAPART, *L'Art ég.* ii, pl. 268; id. in GLANVILLE, *The Legacy of Egypt*, pl. 5; MASPERO, *Égypte*, fig. 167; id. *Guide*, fig. 103, p. 316 [3127]; DE MONTGON, *L'Égypte*, fig. on p. 46; RANKE, *The Art of Ancient Egypt*, and BREASTED, *Geschichte Aegyptens* (1936), 77; incomplete, LARSEN, *En Egyptisk Aeventyrare*, fig. on p. 113; CHAMPDOR, op. cit. fig. on p. 121 (as Dyn. VI); two men carrying chest, TZARA and SVED, *L'Égypte face à face*, pl. on p. 36; see BREASTED (Jr.), op. cit. pp. 66-7 [Type 4, 1].



Musicians before deceased seated, JE 39130. QUIBELL, *Saqqara (1906-1907)*, pl. xvi, pp. 10, 74-5; QUIBELL (A. A.), *Egyptian History and Art*, pl. ix; MASPERO, *Égypte*, fig. 168; id. *Guide*, fig. 102, p. 316 [3126]; RANKE, *The Art of Ancient Egypt*, and BREASTED, *Geschichte Aegyptens* (1936), 85; HICKMANN, *45 Siècles*, pl. lxx [B]; id. *Ägypten*, Abb. 36; id. in *Orientalische Musik*, Taf. i [2]; [id.] *Music under the Pharaohs* (The Egyptian State Tourist Department), fig. on p. 7; one harpist, id. in *Ann. Serv.* xlix (1949), fig. 9, p. 432 with note 2; id. in *Bull. Inst. Ég.* xxxv (1952-3), fig. 15, p. 323; see BREASTED (Jr.), op. cit. pp. 87-8 [1].

Carpenters, JE 39129. QUIBELL, *Saqqara (1906-1907)*, pl. xvii [4], pp. 10, 75; MASPERO, *Guide*, fig. 101, p. 316 [3125]; RANKE, *The Art of Ancient Egypt*, and BREASTED, *Geschichte Aegyptens* (1936), 83; TZARA and SVED, *L'Égypte face à face*, pl. on p. 60; see BREASTED (Jr.), op. cit. p. 50 [Type 2, 1].

Potter's workshop, three models, JE 39131-2, 39147. QUIBELL, *Saqqara (1906-1907)*, pls. xvii [1, 3], xviii [4], xix [4], pp. 10, 11, 75, 76. JE 39131 (= pl. xvii [1, 3]), PRITCHARD, *Anc. Near East*, fig. 146; BOSTICCO and GARBINI in *Encyclopedia of World Art*, iv, pl. 460 [top right] (as New York); incomplete, CHAMPDOR, *Thèbes aux cent portes*, fig. on p. 83; JOHNSTON in *The Biblical Archaeologist*, 37 (1974), fig. 6 on p. 97; man throwing pot, TZARA and SVED, op. cit. pl. on p. 58; see BREASTED (Jr.), op. cit. pp. 51-2 [3]. JE 39132 (= pl. xix [4]), see id. ib. p. 50 [Type 1, 1]; MASPERO, *Guide*, p. 315 [3124] (probably).

Rope-makers, in Cairo Mus. QUIBELL, *Saqqara (1906-1907)*, pl. xviii [2], pp. 11, 75; see BREASTED (Jr.), op. cit. p. 55 [3].

Spinning-sheds, two models in Cairo Mus. QUIBELL, *Saqqara (1906-1907)*, on pl. xiii, xix [2], pp. 8, 11, 74, 76 (as vineyards); see BREASTED (Jr.), op. cit. pp. 53 [5], 54 [6].

Shaft No. 289. KHENU  and IPIEMSAF  IPI, both Overseers of the Temple, etc. Middle Kingdom.

Fragment of false-door of Khenu. QUIBELL, *Saqqara (1906-1907)*, pl. ix [4], p. 73.

Burial chamber. Id. ib. pp. 15-17; view *in situ*, pl. xxvii.

Khenu. Objects in Cairo Museum.

Inner rectangular wooden coffin, JE 39052; id. ib. pl. xxviii; coffin-texts, LACAU in ib. pp. 57, 58-61; DE BUCK, *Coffin Texts*, ii, iii, vi, vii, Sq 4 C. Inscribed wooden sticks and clubs, Temp. Nos. 20.3.31.7-10; texts, QUIBELL, op. cit. p. 17. Rowing-boat with inscribed statuette of deceased, JE 39145, 39149; id. ib. pl. xxix, pp. 16, 77.

Ipiemsaf.

Canopic-box; id. ib. pp. 15-16, with text.

Shaft No. 276. THA , Overseer of the expedition, Regulator of a phyle, etc. Early Middle Kingdom.

QUIBELL, *Saqqara (1906-1907)*, pp. 19-20.



Burial chamber. Painted decoration.

View of south wall, id. ib. pl. xxx [3], p. 77. Name and titles from canopic-box, id. ib. p. 20.

Fragments of wooden statuettes. Id. ib. pl. xxxii [3], pp. 19, 78.

Intrusive find from shaft.

Royal statue (legs below knees missing), possibly Teti, granite, in Cairo Mus. JE 39103. Id. ib. pl. xxxi, pp. 19, 77; WEIGALL, *Anc. Eg. . . . Art*, 77 [left upper and right]; STEINDORFF, *A Royal Head*, pl. 18, pp. 15-16 [31] (as 1st Int. Per.); upper part, LOUKIANOFF in *Bull. Inst. Ég.* xv (1932-3), pl. iv [2], p. 91; see SMITH, *Hist. Eg. Sculp.* p. 82; *Descr. somm.* No. 6185.

‘APERIR , (also ) , Governor of the town, Vizier, etc. Probably temp. Amenophis IV.

Map LI.

Wife, Weriai .

Texts, PETRIE in SAYCE MSS. 14b, c [top]. Name of deceased, RANKE, *Die ägyptischen Personennamen*, i, p. 60 [14].



FINDS

Statues.

Female statuette, incomplete, wood, perhaps Old Kingdom. QUIBELL, *Saqqara (1906-1907)*, pl. xxxii [1], p. 78.

Two female statuettes, wood, Middle Kingdom. Id. ib. pl. xxxii [2], pp. 3, 78.

Male head, quartzite, end of Dyn. XXV or early Dyn. XXVI, in Cairo Mus. JE 38561. QUIBELL, *Saqqara (1905-1906)*, pl. xxx [1, 2], p. 29.

Thauneb-hezet , daughter of Khuenkhnun , Prophet of Amen-rē, and Sit-ḥap , wood, Late Period, in Cairo Mus. JE 39158. Id. ib. (1906-1907), pl. xxxii [4, 5], p. 78.

False-doors. 1st Int. Period or early Middle Kingdom.

Ḥarshefnakht , Overseer of the expedition, Regulator of a phyle, formerly in Cairo Mus. JE 38556, now in Port Sa‘id Mus. QUIBELL, *Saqqara (1905-1906)*, pl. xii, cf. on v, p. 20.

Ḥetepi , Scribe of the treasury of the Pyramid of Merykarē, etc., in Cairo Mus. JE 39102. Id. ib. (1906-1907), pl. vi [2], p. 72.



Ḥetepmert , (woman), in Cairo Mus. CG 57197 (JE 38554).

Ḥetepmert-teti , fragment. Name, id. ib. p. 3 [bottom].

Inbi , fragment. Id. ib. pl. viii [6], p. 73.

Inpuemḥēt , Regulator of a phyle of the Pyramids of Teti and Merykarē, etc., false-door in Cairo Mus. CG 57211 (JE 38552), side-piece with registers, I, herdsman bringing bull, and man with bowl and knife, II, offering-bringers, III, man censuring before



deceased and wife Sitsobk , in New York, M.M.A. 10.175.71, another in Cairo Mus. JE 38560. Id. ib. (1905-1906), pls. xv, xix [3], pp. 22-4 (text), 26. False-door, see MASPERO, *Guide*, p. 90 [264]. Side-piece in New York, HAYES, *Scepter*, i, fig. 87, pp. 145-6; I, FISCHER in *Artibus Asiae*, xxii (1959), fig. 7, p. 250 with note 15.

Ipi  In , Regulator of a phyle of the Pyramid of Merykarē, etc., in Cairo Mus. CG 57212 (JE 38557). QUIBELL, *Saqqara* (1905-1906), pl. xiii, pp. 20-2; see MASPERO, op. cit. p. 90 [263].

Ipi'ankhu , fragment, in Munich, Staatl. Sammlung, Gl. 110. QUIBELL, op. cit. (1905-1906), pl. xvii [5].

Ipi'ankhu, top missing, in Leyden Mus. F.1939/2.6. Id. ib. (1906-1907), pl. vii [1], p. 72.

Karenen , fragment, in Munich, Staatl. Sammlung, Gl. 111. Id. ib. (1905-1906), pl. xvii [1], p. 25.

Kheti , Irti-teti'ankh , Scribe of divine books, Director of the estates of the Red Crown, etc., in Cairo Mus. CG 57209 (JE 38559). Id. ib. pls. xi, cf. ix [lower], p. 20.

Khuwisobk , fragment of panel, in Munich, Staatl. Sammlung, Gl. 116. Id. ib. (1906-1907), pl. ix [2], p. 73.

Khuy , Inspector of prophets of the Pyramid of Teti, Elder of the physicians of the Great House, Greatest of the dentists, etc., in Cairo Mus. CG 57210 (JE 38558). Id. ib. (1905-1906), pl. xiv, p. 22; GHALIUNGUI in *Egypt Trav. Mag.* No. 108 (Aug. 1963), p. 24 with fig. 2.

Mertiyt , (woman), upper part. QUIBELL, op. cit. (1905-1906), pl. xvii [2], p. 25.

Mert-teti-iyt , Mert (woman), lower part, in Munich, Staatl. Sammlung, Gl. 108; id. ib. (1906-1907), pl. x [1], p. 73. Lower parts of side-pieces, in Chicago, formerly in Art Inst. 10.223-4, now in Or. Inst. 17361-2; id. ib. pl. x [2, 3], pp. 18, 73; ALLEN, *A Handbook of the Egyptian Collection* (1923), figs. on p. 30.

Nit'ankh-ḥor , lower part. QUIBELL, op. cit. (1905-1906), pl. xvii [6], p. 25.



Sentni , (woman). Id. ib. (1906-1907), pl. vi [1], p. 72.

Sip , Overseer of commissions, fragments. Id. ib. pl. ix [5, 6], p. 73.

Sit-khemt , (woman), in Cairo Mus. CG 57202 (JE 38553). Id. ib. (1905-1906), pl. xvi [right], p. 24.

Teti-ḥaishtef , Regulator of a phyle, Lector-priest, two fragments, in Munich, Staatl. Sammlung, Gl. 112. Id. ib. (1906-1907), pl. viii [1, 2], pp. 18, 72.

Teti-ḥirmenkhet , Great *warb*-priest, etc., in Munich, Staatl. Sammlung, Gl. 118. Id. ib. pl. vii [3], p. 72.

Theset , Mestni , King's sole adorer, Prophetess of Ḥaṭḥor, etc., in Cairo Mus. CG 57206 (JE 38555). Id. ib. (1905-1906), pl. xvi [left], p. 24.

Weny-impy (?) , Eldest lector-priest, etc., fragment. Id. ib. (1906-1907), pl. vii [2], p. 72.

Wepeti , (woman), fragment. Id. ib. (1905-1906), pl. xvii [4], pp. 4, 25.

Side-pieces. 1st Int. Period or early Middle Kingdom.

Ḥetepmert , (woman). One, in Chicago, Art Inst. 10.225, another in Cairo Mus.

JE 38542. Side-piece in Chicago, QUIBELL, *Saqqara* (1905-1906), pl. xix [2], p. 26; ALLEN, *A Handbook of the Egyptian Collection* (1923), fig. on p. 32.

Ipi $\text{𓂏} \text{𓂏} \text{𓂏}$, Overseer of the expedition, etc., fragment with [deceased] and netting fowl, in Chicago, formerly in Art Inst. 10.230, now in Or. Inst. 17365. QUIBELL, op. cit. pl. xx [5], pp. 8, 26; ALLEN, op. cit. fig. on p. 34, cf. p. 35; netting fowl, WRESZ., *Atlas*, iii. 73 [B].

Ipi'ankhu $\text{𓂏} \text{𓂏} \text{𓂏}$, fragment with three registers, I, ploughing, II, reaping and gleaning, III, deceased fowling, in Chicago, formerly in Art Inst. 10.232, now in Or. Inst. 17366. QUIBELL, op. cit. pl. xx [2], p. 26; ALLEN, op. cit. fig. on p. 28. II, WRESZ., *Atlas*, iii. 55 [B].

Tetiemsaf $\text{𓂏} \text{𓂏} \text{𓂏}$, bottom part with offering-bringers, in Chicago, formerly in Art Inst. 10.229, now in Or. Inst. 17364. QUIBELL, op. cit. pl. xx [3], p. 26; ALLEN, op. cit. fig. on p. 33, cf. pp. 34-5.

Man (no name) before table, with offering-list. QUIBELL, op. cit. pl. xx [1], p. 26.

Offering-list, priests, and remains of butchers, fragment, in New York, M.M.A. 10.175.72. Id. ib. pl. xix [1], pp. 25-6; HAYES, *Scepter*, i, fig. 88, p. 146; priests, MICHALOWSKI, *Art*, fig. 267.

Remains of offering-list and offering-bringers, fragments, in Munich, Staatl. Sammlung, Gl. 119. QUIBELL, op. cit. (1906-1907), pl. viii [5], p. 73.

Man (no name) fowling, with wife, fragment. Id. ib. (1905-1906), pl. xx [4], p. 26.

Oil-vases and remains of offering-bringers, fragment. Id. ib. (1906-1907), pl. ix [3], p. 73.

Man with birds and remains of butchers, fragment. Id. ib. pl. viii [3], p. 73.

Two offering-bringers, priest, and remains of butchers, fragment, in Munich, Staatl. Sammlung, Gl. 114.

Lintels, blocks, etc. 1st Int. Period or early Middle Kingdom unless stated.

Three fragments with name Khety $\text{𓂏} \text{𓂏} \text{𓂏}$, from same block, formerly von Bissing Colln. and Munich, Staatl. Sammlung, Gl. 117, now in Leyden Mus. F.1939/2.15, 42-3. One (F.1939/2.42), QUIBELL, *Saqqara* (1905-1906), pl. xvii [3], p. 25.

Block, Khety, son of Menekh-hathor $\text{𓂏} \text{𓂏} \text{𓂏}$, and Sit-impy $\text{𓂏} \text{𓂏} \text{𓂏}$, daughter of Impy-sokari $\text{𓂏} \text{𓂏} \text{𓂏}$, in Cairo Mus. JE 39228. Id. ib. (1906-1907), pl. vii [4], pp. 19, 72.

Mertiotes $\text{𓂏} \text{𓂏} \text{𓂏}$ Merit $\text{𓂏} \text{𓂏} \text{𓂏}$, Prophetess of Hathor, King's sole adorer, lintel-fragment with deceased standing and seated. Id. ib. pl. ix [1], p. 73.

Wac $\text{𓂏} \text{𓂏} \text{𓂏}$, Abdominal physician, Eye physician, block with upper part of deceased adoring, mentioning Ipi $\text{𓂏} \text{𓂏} \text{𓂏}$. Id. ib. pl. viii [4], p. 73; GHALIUNGUI in *Egypt Trav. Mag.* No. 108 (Aug. 1963), fig. 8, p. 27.

Block with text mentioning mother Wen $\text{𓂏} \text{𓂏} \text{𓂏}$ and names of Sesostris I, in Munich, Staatl. Sammlung, Gl. 121. QUIBELL, *Saqqara* (1906-1907), pl. viii [7], p. 73.

Coffins. 1st Int. Period or early Middle Kingdom.

Ipi'ankhu $\text{𓂏} \text{𓂏} \text{𓂏}$. QUIBELL, *Saqqara* (1905-1906), pl. xxiii, pp. 7-8, 27.

Ipi-senbes $\text{𓂏} \text{𓂏} \text{𓂏}$. See id. ib. (1906-1907), p. 19, cf. pl. xxx [4], p. 77.

Irt-nub $\text{𓂏} \text{𓂏} \text{𓂏}$ Irt (woman). See id. ib. (1905-1906), p. 8.

Mert-teti-iyt $\text{𓂏} \text{𓂏} \text{𓂏}$. See id. ib. p. 7.

Shemai $\text{𓂏} \text{𓂏} \text{𓂏}$, Treasurer of the King of Lower Egypt, etc. Name and titles, id. ib. p. 7.

Offering-tables. 1st Int. Period or early Middle Kingdom. In Cairo Mus.

Hepi $\text{𓅓} \text{𓅓}$, Inspector of embalmers, CG 57015 (JE 38429). QUIBELL, *Saqqara* (1905-1906), pl. xviii [4], p. 25.

Inpuemhêt-wêr $\text{𓅓} \text{𓅓} \text{𓅓}$, CG 57018 (JE 38428). Id. ib. pl. xviii [2], p. 25.

Inpuemsaf $\text{𓅓} \text{𓅓} \text{𓅓}$, CG 57017 (JE 38426). Id. ib. pl. xviii [1], pp. 4, 25.

Men'ankh-pepy $\text{𓅓} \text{𓅓} \text{𓅓}$ [Meni] $\text{𓅓} \text{𓅓}$, Overseer of the Two Granaries, etc., and Ni[ankh]-ḥathor $\text{𓅓} \text{𓅓}$ [ḥathor], Prophetess of Ḥathor, alabaster, CG 57014 (JE 38427). FISCHER, *Dendera in the Third Millennium B.C.*, pl. iv, fig. 6, pp. 27-8 [9] with note 117.

Senzemib $\text{𓅓} \text{𓅓} \text{𓅓}$ Ḥ Bibi $\text{𓅓} \text{𓅓}$, Overseer of scribes, Judge and Inspector of bookkeepers, etc., CG 57016 (JE 38430). QUIBELL, op. cit. pls. xviii [3], cf. ix [upper], pp. 19, 25.

Various. 1st Int. Period or early Middle Kingdom.

Canopic-boxes. (a) Ipiemsaf $\text{𓅓} \text{𓅓} \text{𓅓}$; see QUIBELL, *Saqqara* (1906-1907), pp. 17-18.

(b) Senebim $\text{𓅓} \text{𓅓} \text{𓅓}$; id. ib. pl. xxx [2], pp. 18, 77.

Wooden fragment of Khentemhêt $\text{𓅓} \text{𓅓}$. See id. ib. (1905-1906), p. 6.

Sealing of a Judge and Boundary official, etc., with name of Neuserre'. Id. ib. (1906-1907), pl. v [1], p. 71.

WEST AND SOUTH-WEST OF THE PYRAMID

(a) OLD KINGDOM

LS 20 [C 26].¹ IY $\text{𓅓} \text{𓅓}$, Treasurer of the God in the two boats, Overseer of the expedition, Secretary of all foreign countries, etc. Dyn. V or later.

Wife, Nefert 𓅓 , Prophetess of Ḥathor Mistress of the Sycamore and Neith Opener of the Ways in all her pure places, etc.

MARIETTE, *Mastabas*, pp. 161-2, with plan of chapel; PETRIE (H.) and MURRAY, *Seven Memphite Tomb Chapels*, pp. 3-5 (as Nefert), with plan of chapel, pl. xviii [1].

False-door of wife, in Cairo Mus. CG 57124. L. D. ii. 100 [b]; PETRIE (H.) and MURRAY, op. cit. pls. i (frontispiece), ii, cf. xviii [3], pp. 4-5 [17], 17 [86]; text at top, MARIETTE, op. cit. p. 162; WILKINSON MSS. xiii. 29.

(b) LATE PERIOD

PEDEPEP 𓅓 . Dyn. XXVI.

Map LI, E-4.

Mother, Ubasteardais $\text{𓅓} \text{𓅓}$.



Four canopic-jars, alabaster, in Cairo Mus. CG 4266-9. Texts, REISNER, *Canopics*, pp. 183-5.

LS 18. HOR 𓅓 , Royal scribe. Dyn. XXVI.

Mother, Mertneit $\text{𓅓} \text{𓅓}$.

Name and title from sarcophagus; L. D. Text, i, p. 172.

¹ The position in PETRIE (H.) and MURRAY, *Seven Memphite Tomb Chapels*, pl. xxvii, is incorrect.

LS 19. PSAMMETHEK-NEBPEḤTI  , Commander of the army.
Dyn. XXVI.

Parents, Psammethek  and Tashenēsi .
L. *D. Text*, i, pp. 172-3. Section, L. *D.* iii. 279 [d].

West room.

West, north and south walls. Texts, id. ib. 279 [a-c]; four columns left of niche on west wall, NESTOR L'HÔTE MSS. 20396, 327.

Sarcophagus, anthropoid, basalt, in Cairo Mus. Temp. No. 21.11.14.6. Divinities and text on lid, L. *D.* iii. 279 [e]; DEVÉRIA squeezes, 5374C; texts, WILKINSON MSS. xiii. 27 [lower]-28. Names of divinities, LANZONE, *Diz.* ii, p. 926 [v]. See BUHL, *Sarcophagi*, pp. 22-3 [A, 4], cf. pl. i.

FIRTH EXCAVATION

Exact location or provenance unknown but near the Pyramid of Teti

(a) DYN. VI AND 1ST INT. PERIOD

SHEDABD , Count, Inspector of prophets of the Pyramid of Teti, etc.
Dyn. VI or 1st Int. Period.

Mother, Hebyt , Prophetess of Ḥaṭḥor, etc.

Doorway. Lintel with offering-text and deceased seated, jambs with name and titles and deceased at bottom. GUNN MSS. R.1.13, 14; 6.1; xiv. 62 (photos. and tracings).

Texts of another lintel and parts of jambs, id. ib. xv. 40-1; Notebook, 9, Nos. 29, 30; 12, No. 116.

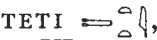
THETETI , Overseer of scribes of the sealed documents, etc. Late Dyn. VI.

False-door and lintel. False-door, GUNN MSS. xiv. 46 [1]; R.1.15 (photos. and tracing); Notebook, 11, No. 90. Text of lintel, id. MSS. xv. 12; Notebook, 10, No. 38.

Statues.

Deceased seated, in Boston Mus. 24.605. VANDERSLEYEN, *Das Alte Ägypten*, Abb. 146; GUNN MSS. xiv. 41 [2] (photo.). See SMITH, *Anc. Eg.* (1942), p. 58; (1952), p. 57; (1960), p. 63; id. *Hist. Eg. Sculp.* p. 88.

Wooden statuettes.

Three, two of them in long kilt, in Boston Mus. 24.606-8. GUNN MSS. xiv. 41 [1] (photo.), 41A (texts). No. 24.608, HORNEMANN, *Types*, i, pl. 186; TERRACE in *The Connoisseur*, clxviii (1968), fig. 15, p. 204. See SMITH, *Hist. Eg. Sculp.* p. 88.

One, in long kilt, in Cairo Mus. JE 49371. *Encycl. phot. Caire*, pl. 43; BEEKMAN, *Hout in alle Tijden*, fig. 7.92 on p. 543; HORNEMANN, *Types*, i, pl. 182.

Two (one seated), in Neuchâtel Mus. Eg. 328-9. GUNN MSS. xiv. 43 [2, left], 44 (photos.); cf. GABUS in *Museum*, xviii [2] (1965), fig. 1 [near left] on p. 66. See id. *175 ans*, Pt. i, pp. 55 [21], 52 [top, 5].

Two, in New York, M.M.A. 26.2.8, 9.

Three, in Stockholm Mus. MM. 11411-13. GUNN MSS. xiv. 43 [1, three on left]. MM. 11411, see Stockholm. 5000 år, p. 78 [30]. MM. 11413, ib. No. 31 with fig. (as MM. 11412); upper part, Medelhavsmuseet Stockholm. *Vägen till evigheten. Sex tusen år egyptisk konst*, fig. 2, p. 32 [57].

Six, GUNN MSS. xiv. 42 [2], 43 [1, right], 43 [2, middle and right] (photos.).

Wooden models.

Man with hoe, in New York, M.M.A. 26.2.10. BREASTED (Jr.), *Eg. Servant Statues*, pl. 1, p. 6 [2].

Two women carrying baskets, in Neuchâtel Mus. Eg. 330. GABUS, *175 ans*, Pt. 2, pl. 5 on p. 165, cf. Pt. i, p. 55 [4].

Male and female offering-bringers, probably from here. GUNN MSS. xiv. 40 [1, 2], 42 [1] (photos.).

FINDS

Statues.



Khenu , Sole companion, lower part of seated statue. Name and title, GUNN MSS. xv. 14; Notebook, 10, No. 58.

False-doors.

Ḥarshefhotp , Text, GUNN MSS. xv. 42; Notebook, 10, No. 51.

Ḥetepmert-teti, upper part. Text, GUNN MSS. on xv. 35b; Notebook, 11, No. 72.

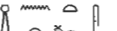
Imai , Overseer of tenants of the Pyramid of Teti, Chief of the estate, etc. Text, GUNN MSS. xv. 30; Notebook, 10, No. 44.

Intiotes , Init , Prophetess of Ḥathor, etc., upper part. GUNN MSS. xiv. 51 [2] (photo.); Notebook, 9, No. 25.

Ipiemsaf , Ipi. Text, GUNN MSS. xv. 27; Notebook, 9, No. 21.

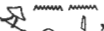

Iti , Eldest lector-priest, Prophet of Min Lord of Panopolis, etc. FISCHER in *A.Z.* 90 (1963), Taf. v, pp. 35-6, 38-41; GUNN MSS. R.6.4; xiv. 46 [3] (photos. and tracing); Notebook, 9, No. 20.

Iurez , Text, GUNN MSS. xv. 16; Notebook, 11, No. 73.

Khentni , Lector-priest. Text, GUNN MSS. xv. 24; Notebook, 11, No. 74.

Khenu , Steward, etc. GUNN MSS. R.6.3; xiv. 46 [2] (photos. and tracing); Notebook, 9, No. 23.

Khety , Secretary of the God's treasure, etc., two fragments. Texts, GUNN MSS. on xv. 35a; Notebook, 10, No. 63.



Ky , Scribe of the Two Granaries and of the Pyramid-town, etc., and wife Sitshedabd , double false-door with side-pieces, in Louvre, E.14184. GUNN MSS. xiv. 57; R.1.8; 13.4 (photos. and tracing); Notebook, 12, Nos. 100-2; ARCHIVES phot. E.1049-50. Men with bull, from right side-piece, FISCHER in *Artibus Asiae*, xxii (1959), fig. 9, p. 250. See *Annuaire des Musées Nationaux* (1932), p. 23; BOREUX, *Guide*, i, pp. 247-8; VANDIER, *Guide* (1948), p. 11; (1952), p. 12; (1973), p. 18.

Mehu , Scribe, two fragments. Texts, GUNN MSS. on xv. 35a; Notebook, 10, No. 61.

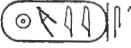

Mereru , Director of the dining hall. Text, GUNN MSS. xv. 10; Notebook, 9, No. 3.

Meri , Prophetess of Ḥathor, fragment. Text, GUNN MSS. on xv. 35a; Notebook, II, No. 69.

Meryrēsonb , Judge and Scribe, etc. Text, GUNN MSS. xv. 36; Notebook, 9, No. 8.



Metety  Mem , Eldest lector-priest, etc. Text, GUNN MSS. xv. 23; Notebook, 10, No. 46.

Nakhty , fragment. Text, GUNN MSS. on xv. 35a; Notebook, 10, No. 62.

Neferkhuu , Inspector of scribes of petitions, Prophet of Rē in the Sun-temple of Userkaf, etc., false-door with deceased with son Sekhentiu-ptah  on jambs, and lintel (originally above this false-door and another on right, now lost), with text of deceased on left and presumably wife Khuit , Prophetess of Ḥathor and Neith, on right (changed from Sekhentiu-ptah, probably father), wood, Dyn. V (Vandier) or Dyn. VI, in Louvre, E.17233. VANDIER in *Musées de France*, April 1948, figs. 5, 6, pp. 56-8; GUNN MSS. R.3.4-7; xx. 8 (by Quibell); Notebook, 25, No. 3. Panel, VANDIER in *La Revue du Louvre*, xvii (1967), fig. 3, p. 302; id. *Manuel*, ii, fig. 282 [lower], p. 428; EGGBRECHT, *Schlachtungsbräuche im Alten Ägypten*, Taf. vi [A], p. 224 [2, A]. Right half of lintel with palimpsest text, and son on left jamb, FISCHER in *Ä.Z.* 86 (1961), figs. 2, 3, pp. 28-9. See *Vingt ans*, p. 20 [Cat. 71]; VANDIER, *Guide* (1948), p. 10; (1952), pp. 10-11; (1973), p. 16.

Net . . . . Text, GUNN MSS. xv. 29; Notebook, 9, No. 27.

Ni'ankh-teti , Tenant of the Pyramid of Teti, etc., false-door and fragment of side-piece. Texts, GUNN MSS. xv. 17, 18; Notebook, 10, No. 43; II, No. 67.

Sebkhotp  Ḥepi , Inspector of tenants of the Great House. Text, GUNN MSS. xv. 31; Notebook, 10, No. 45.

Seni  King's sole adorer, Prophetess of Ḥathor, etc., in Neuchâtel Mus. Eg. 426. GUNN MSS. R.1.5; xiv. 45 [4] (photos. and tracing), 45B; Notebook, 9, No. 24; see GABUS, *175 ans*, Pt. i, p. 54.

Seni, Lector-priest, Regulator of a phyle, etc., several fragments. GUNN Notebook, 10, Nos. 33-6, 60; MSS. on xv. 35b.



Sentiotes  King's sole adorer, Prophetess of Ḥathor, in Stockholm Mus. MM. 11434. WÄNGSTEDT in *Medelhavsmuseet Bulletin*, I (1961), Abb. 1, pp. 43-5, 47; GUNN MSS. xiv. 51 [1], 52 [2]; R.1.9 (photos. and tracing); Notebook, 9, No. 22.

Sesi, Prophetess of Iput I, etc., 15 fragments. Texts, GUNN MSS. on xv. 35a, b; Notebook, 10, No. 59.

Sit-iythenu  King's sole adorer, Prophetess of Ḥathor, in Cairo Mus. JE 59158. FISCHER in *Ä.Z.* 90 (1963), Taf. vi, pp. 36-7; GUNN MSS. xiv. 47 and R.1.11 (photos. and tracing); Notebook, 10, No. 42. See GAUTHIER in *Rec. Trav.* xl (1923), p. 198 [21].

Teti . . .  Chief lector-priest, fragment. Text, GUNN MSS. on xv. 35b; Notebook, 12, No. 115.

Weput  Prophetess of Ḥathor, etc. Text, GUNN MSS. xv. 34; Notebook, 10, No. 54.

Werkai  Gold-worker of King's adorners, and mother Khentetka  at table, with threat, panel, in Neuchâtel Mus. Eg. 323. GUNN MSS. R.1.6 and xiv. 48 [1] (photos. and tracing).

. . . hotp . Text, id. ib. xv. 32; Notebook, 10, No. 39.

Side-pieces and lintels of false-doors.



Ḥarshefnakht, Treasurer of the King of Lower Egypt, etc., side-piece. Text, GUNN MSS. xv. 21; Notebook, 9, No. 17 (including offering-list).



Ḥarshefnakht, fragments of side-piece. Text, id. ib. 12, No. 112.



Ḥep  □, fragment of side-piece. Text, GUNN MSS. xv. 19; Notebook, 11, No. 70.

Inti  □ (woman), probably part of side-piece decorated on two sides, (a) deceased, (b) lower part of man with offering-bringer with goose below. Text, id. ib. 9, No. 28.

Ipi  □ □, Lector-priest, Steward, fragments of side-piece. Texts, id. ib. 10, No. 64.



Ipiʿankhu  □ □ □  □, Overseer of the expedition, side-piece with preliminary sketches. Text, GUNN MSS. xv. 13; Notebook, 9, No. 16.





Ipiisenbes  □ □ □  □ (woman), part of side-piece. Text, id. ib. 11, No. 66.



Khuenptah  □  □, Noble of the King, Companion of the house, 'Honoured by Meri'  □, Count' (probably Mereruka), side-piece. GUNN MSS. xiv. 56 [1] (photo.), 56B; Notebook, 10, No. 47 (text).



Mert  □ (woman), side-piece; text, id. ib. 11, No. 85. Fragment of offering-list, probably making pair with side-piece; text, GUNN MSS. xv. 45; Notebook, 11, No. 86.

M . . .  . . . , Treasurer of the King of Lower Egypt, etc., part of side-piece with registers, **I**, oil-vases, **II**, jewelry, **III**, ploughing, sowing and hacking ground, **IV**, remains of netting fowl. Text, id. ib. 11, No. 88.

Senenuʿankh  □  □, Scribe of the royal documents in the presence, etc., lintel. Text, GUNN MSS. xv. 28; Notebook, 9, No. 7.

Sit-ḥathor  □  □ (woman), side-piece, offering-text on edge, and three registers, **I**, daughter Ptaḥemsas  □  □ before deceased, **II**, two female attendants, **III**, two offering-bringers, in Stockholm Mus. MM. 11432. PETERSON in *Orientalia Suecana*, xxi (1972), pl. facing p. 4, fig. on p. 4, cf. pp. 3-8; sketch and texts, GUNN Notebook, 11, No. 81.

Sit-impy  □  □ (woman), part of side-piece. Text, id. ib. 10, No. 49.



Wazet-ipi  □  □, side-piece with remains of offering-list, butchers and deceased at table. Text, id. ib. 9, No. 26, and MSS. xv. 43.

Lintel of a woman. Text, id. ib. xv. 22; Notebook, 10, No. 41.

Fragment of side-piece, with offering-bringers in upper register. Sketch, id. ib. 9, No. 18.

Fragments of offering-list. Texts, (a) id. ib. 9, No. 19; (b) id. MSS. xv. 44; Notebook, 11, No. 83; (c) id. ib. 12, No. 113; MSS. xv. 46; (d) id. Notebook, 12, No. 117; MSS. xv. 47.

Blocks, etc.

Impy  □  □ Ḥeneni  □ with wife. Text, GUNN MSS. xv. 26; Notebook, 11, No. 80 (sketch).



Ipi, Overseer of 'Hair of the Earth', with part of conventional autobiographical text. Text, GUNN MSS. xv. 20; Notebook, 11, No. 71.



Iri  □, *warb*-priest of the two hundred of the Pyramid of Pepy II, etc., architrave-fragment with two figures of deceased, at one time in Owens Colln. *Antiquities (Parke-Bernet Sale Cat.)*, Nov. 5, 1971, pl. ii [11], p. 2; GUNN MSS. xiv. 55 [1] (photo.), 55B (text); Notebook, 9, No. 15.

Iri, Chief of the estate, etc., represented twice, architrave-fragment. Text, GUNN MSS. xv. 11; Notebook, 9, No. 4.

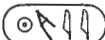

¹ Reversed.

Mehi , Overseer of the department of tenants of the Great House, etc. Text, GUNN MSS. xv. 15; Notebook, 11, No. 65.

Meryrē-cankh  Iri , Judge and Scribe of petitions, architrave, temp. Pepy I or later. Text, GUNN MSS. xv. 2.7.

Seni , Tenant of the Pyramid of Pepy I, etc., wife Sesi , Prophetess of Iput I, and son Hēpi , Regulator of a phyle, etc. Text, id. ib. xv. 9, 9A; Notebook, 9, Nos. 31-2.

Upper part of Si[en]unis , Lector-priest, bringing bird, Dyn. VI. Sketch, id. ib. 11, No. 75.

Usermut  and wife Hēnut , with address. Id. MSS. xiv. 55 [3], 56 [2, right] (photos.), 55A; Notebook, 9, Nos. 6, 6A (text).

Tenant, and *warb*-priest of the two hundred, of the Pyramid of Pepy II, architrave-fragment. Text, GUNN MSS. xv. 37; Notebook, 9, No. 14.

Boatmen jousting, Dyn. V-VI, in Neuchâtel Mus. Eg. 321. GABUS, 175 ans, Pt. 2, pl. 1 on p. 161, cf. Pt. 1, pp. 49, 54 [paroi nord, 2nd item].

Herdsmen with cow suckling calf, Dyn. V-VI, in Neuchâtel Mus. Eg. 322. Id. ib. Pt. 2, pl. 2 on p. 162, cf. Pt. 1, pp. 49, 54 [paroi nord, 1st item]; GUNN MSS. xiv. 50 (photo.).

Part of offering-list. Id. ib. xiv. 56 [3] (photo.), 56A (text).

Butcher, Dyn. VI. Sketch and text, id. Notebook, 11, No. 78.

Coffins. Rectangular, wooden.

Hēpi , Lector-priest, etc., usurped. Text, GUNN MSS. xx. 12 (by Quibell).

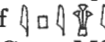
Ipi-haishtef  Ipi, Scribe and Overseer of the expedition, in Chicago, Or. Inst. 12072. GUNN MSS. xiv. 58-9, 60 [1], xv. 5 (photos. and drawings). View, *Handbook and Museum Guide* (1941), fig. on p. 20; MERTZ, *Temples, Tombs and Hieroglyphs*, pl. facing p. 97; showing part of coffin-texts, BREASTED, *The Oriental Institute*, fig. 67.

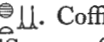
Ipi-hirmenkhet  Coffin-texts, DE BUCK, *Coffin Texts*, iv, v, Sq 7 Sq. Offering-texts on exterior, GUNN MSS. xx. 2 (copy by Quibell).

Khui(t)neit (woman). Id. ib. xiv. 63 [1, 2] (photos.).









Saby , Treasurer of the King of Lower Egypt. Offering-text, id. ib. xx. 9 (by Quibell).

Sit-shedabd  (woman). Offering-text, id. ib. xx. 7 (by Quibell).

Tetiemsaf . See GUNN MSS. xv. 7.

Name unknown, part of lid. Coffin-texts, DE BUCK, op. cit. iv, Sq 8 Sq.

Offering-tables.

Gemni-iy ; GUNN MSS. xiv. 49 [2] (photo.). Kar , Supervisor(?) of tenants; GUNN Notebook, 27, No. 2. Khuit-ba(?)  (?) (woman) and others; id. ib. 27, No. 3. Mestni , Prophetess of Hathor, etc.; id. ib. 31, p. 64. Neternüfer , Overseer of leather-workers, in London, Univ. Coll. 8578; GUNN MSS. R.2.2, Notebook, 27, No. 9; MARTIN, *Hetepka*, No. 76A. Pepy-ma'iu ; GUNN Notebooks, 27, No. 1, and 31, p. 63. Senezemib , Inspector of the Great House, and family; id. ib. 31, p. 65. Shededu-snefru  and wife; id. ib. 27, No. 4.

Shemi $\overline{\text{𓊖}}$ $\overline{\text{𓊗}}$ Seni $\overline{\text{𓊘}}$, Inspector of dancers; GUNN MSS. xiv. 39 [3] (photo.), R.2.5 (squeeze of title), Notebook, 10, No. 48. Werkai; GUNN MSS. xiv. 49 [3] (photo.).

Various.

Ointment-slab of Sekhemptah $\overline{\text{𓊙}}$ $\overline{\text{𓊚}}$ $\overline{\text{𓊛}}$ $\overline{\text{𓊜}}$ $\overline{\text{𓊝}}$ Sekhemu $\overline{\text{𓊞}}$ $\overline{\text{𓊟}}$, Inspector of hairdressers of the Great House, alabaster. GUNN MSS. R.2.4 (squeeze); Notebook, 12, No. 109.

(b) MIDDLE KINGDOM

Upper part of stela of Mentuhotp and wife Khety $\overline{\text{𓊠}}$ $\overline{\text{𓊡}}$, with list of children, including Sehetepbre-ankh $\overline{\text{𓊢}}$ $\overline{\text{𓊣}}$ $\overline{\text{𓊤}}$ $\overline{\text{𓊥}}$, Greatest of the directors of craftsmen, etc. GUNN MSS. xiv. 48 [2] and R.1.12 (photos. and tracing); Notebook, 9, No. 10.

Fragmentary stela of Senebrau $\overline{\text{𓊦}}$ $\overline{\text{𓊧}}$ $\overline{\text{𓊨}}$, Singer, Bebu $\overline{\text{𓊩}}$ $\overline{\text{𓊪}}$ $\overline{\text{𓊫}}$, Child of the nursery, Singer, and others, probably Middle Kingdom. Text, id. ib. 6, No. 7.

Block with remains of offering-text of 'Ankhu, Steward, mentioning Amenemhet II. Id. ib. 11, No. 68.

Block with cartouche of Sesostris. Id. ib. 11, No. 77.

Offering-table of Senbeb $\overline{\text{𓊬}}$ $\overline{\text{𓊭}}$ $\overline{\text{𓊮}}$, Overseer of Necropolis-workmen, and wife 'Aku $\overline{\text{𓊯}}$ $\overline{\text{𓊰}}$, Dyn. XIII (?), in Cairo Mus. CG 23031. KAMAL, *Tables d'offrandes (Cat. Caire)*, pl. xiv, pp. 25-6.

(c) NEW KINGDOM

NEKHTAMŪN $\overline{\text{𓋀}}$ $\overline{\text{𓋁}}$ $\overline{\text{𓋂}}$, Head of servants of the Royal butler Hōri $\overline{\text{𓋃}}$ $\overline{\text{𓋄}}$. Dyn. XIX.

Views, GUNN MSS. xix. 3 [1, 3] (photos.).

Lower part of stela, remains of people before Ptaḥ in upper register, and deceased with children before Hōri (son of Ptaḥemwia $\overline{\text{𓋅}}$ $\overline{\text{𓋆}}$ $\overline{\text{𓋇}}$), and wife seated, in Neuchâtel Mus. Eg. 428. Id. ib. xix. 3 [2, 4] (photos.); Notebook, 6, No. 4. See GABUS, *175 ans*, Pt. i, p. 55 [top].

Block with remains of kneeling and seated figures and text mentioning Hōri. GUNN Notebook, 6, No. 13.

NAME UNKNOWN. Dyn. XIX.

'Above Abūšîr village' (Gunn).

Father, Say $\overline{\text{𓋈}}$ $\overline{\text{𓋉}}$ $\overline{\text{𓋊}}$, Prophet of Bubastis.

Four blocks, left, man and woman kneeling, with list of slaves, right, purification and Opening-the-Mouth ceremony before statue performed by brother Amenemḥab, God's father in the Temple of Ptaḥ, Prophet in the Temple of Bubastis, and Amenmosi, Head of outline-draughtsmen of the sculptor's workshop in the domain of Ptaḥ, etc., son of Peshedu $\overline{\text{𓋋}}$ $\overline{\text{𓋌}}$ $\overline{\text{𓋍}}$. Texts, GUNN Notebook, 7, No. 42 [i].

Two blocks, three registers, I (lower part only), seated kings, II-III, mummiform figures of famous men of the past, including Viziers Imḥōtep and Ptaḥshepses (tomb, probably p. 340), and Ty, Ptaḥmosi and Paḥemmeter, all Greatest of the directors of craftsmen (tombs, see *infra*), with others including Ipuwēr $\overline{\text{𓋎}}$ $\overline{\text{𓋏}}$ $\overline{\text{𓋐}}$ $\overline{\text{𓋑}}$, Overseer of singers, and Amenhotp, Chief steward of Memphis (tomb, see *infra*), mentioned between registers II-III. GUNN MSS. xix. 8 (photos.); Notebook, 7, No. 42 [ii]. Text and left block, GARDINER MSS. photos. 28.487-8. Right block, SIMPSON and others, *The Literature of Ancient Egypt*, fig. 6.



Left block, to be published by FISCHER. See YOYOTTE in *Bull. Soc. fr. d'Ég.* No. 11 (Oct. 1952), pp. 67-72 (from DARESSY MSS. B. Arch. E 30/1).

Block with head of deceased and remains of text. Text, GUNN Notebook, 7, No. 42 [after ii].

FINDS

Stelae. New Kingdom unless otherwise stated.

Amenemḥēt, Overseer of horses, offering to Osiris, with King Teti behind, probably late Dyn. XVIII, and perhaps later text on *verso*, at one time with Tano (dealer). Photos. and texts, GRDSELOFF MSS. I.125-7; GUNN MSS. xix. 2 [2]; Notebook, 7, No. 41.

Amenemōpet (daughter of woman Bakt ) and Nu  (woman), with brother Amen-hotp, Dyn. XVIII, in Stockholm Mus. MM. 11443. PETERSON in *Opuscula Atheniensia*, ix (1969), Abb. 2, pp. 96-8 [ii]. Text, GUNN Notebook, 7, No. 38.



Itefnūfer . Text, id. ib. 7, No. 46.

Khensia(?)  (?), Khaꜣy , and others. Text, id. ib. 7, No. 39.

Naḥerḥu , Scribe of commands of the army, Ramesside. GUNN MSS. xix. 1 [1] (photo.); Notebook, 7, No. 52.

Neferḥōtep , Mayor, upper part, Ramesside. CAIRO, CENTRE OF DOCUMENTATION photo. S.A., 32 (probably). Text, GUNN Notebook, 6, No. 14.

Pay . Name, id. ib. 7, No. 40.

Ptaḥ-sety , Outline-draughtsman, with King Teti offering to Osiris and deceased and wife Henutyunu  adoring, late Dyn. XVIII or Dyn. XIX, in Boston Mus. 25.635. DUNHAM in *J.E.A.* xxi (1935), pl. xvii [2], pp. 148-9; GUNN MSS. xix. 1 [2]; R.1.2 (photos. and tracing).

Romy , Infantryman, Ramesside. Text, id. Notebook, 6, No. 18.

Ter  e at table, with Neferkhaꜣu  before him, both apparently sons, lower part. Sketch with text, id. ib. 7, No. 47.

... meryrē  ... , two fragments. Sketches with texts, id. ib. 7, No. 50.

Blocks. New Kingdom unless otherwise stated.

‘Aḥa-ꜣa , *warb*-priest, cornice with deceased and wife adoring divinities, Ramesside. GUNN MSS. xix. 7 [1] (photo.); Notebook, 6, No. 10.

Ipay , Deputy administrator of Memphis, Ramesside. Text, id. ib. 6, No. 16.

Iryiry , Sculptor. Text, id. MSS. xv. 2. 6.

Khaꜣemwēset (son of Ramesses II), pillar-fragment. Text, id. Notebook, 7, No. 36.

Meryrē , Overseer of the seal, etc., jamb-fragment, probably New Kingdom. Text, id. ib. 7, No. 49.



Messuy , holding flower, and another man pouring water. Sketch with text, id. ib. 7, No. 51.

Penmeḥy , *warb*-priest, Chiseller, with remains of woman seated, and man with papyrus plants and calf below. Text, id. ib. 6, No. 15.

Heads of men in Opening-the-Mouth ceremony, mentioning Ptaḥmosi, Dyn. XIX, in Boston Mus. 1973.483. GUNN MSS. xix. 11 [2] (photo.); Notebook, 6, No. 9. See *98th Annual Report 1973-4*, p. 14.

Ptaḥmosi and family adoring tree-goddess, Dyn. XIX, in Boston Mus. 34.50. SMITH, *Anc. Eg.* (1942), fig. 82; (1952), fig. 81; (1960), fig. 94; id. *Country Life*, fig. 45; SÉE, *Grandes*

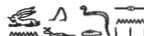
villes, fig. on p. 327 [lower] (all as Giza); GUNN MSS. xix. 2 [1] (photo.); Notebook, 7, No. 43. See *Boston Mus. Bull.* xxxii (1934), p. 38.

Wenefzedsen , First royal butler of His Majesty, with deceased and wife Nay  libating to Ptaḥ in shrine and libating and censng before Ptaḥ-Sokari, in Boston Mus. 24.981. DUNHAM in *J.E.A.* xxi (1935), pl. xviii, pp. 149-50.

Woman and child offering. GUNN MSS. xiv. 56 [2, left] (photo.).

Plan of building, mentioning a Royal scribe, First royal butler of [His] Majesty, Ramesside. Id. ib. xix. 11 [1] (photo.); Notebook, 6, No. 3.

Fragments with incised hieratic text. Transcription, id. ib. 7, No. 53.



Block with bark of Apis-bull. GUNN MSS. xix. 10 [2] (photo.).

Part of cryptographic text, perhaps New Kingdom. GUNN Notebook, 6, No. 6.

(d) OTHERS

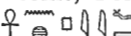

Coffins and fragments. Anthropoid and wooden unless otherwise stated. Ramesside to Roman.

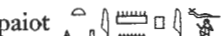

Photographs of some, GUNN MSS. xix. 15-27.

ʿAnkpefḥeri , son of Pakap  and Tadeamūn-paiot , coffin-lid and inscribed mummy-wrappings. Text, GUNN Notebook, 23, No. 17.

Dḥout . Text, id. ib. No. 7.

Imḥōtep , son of Nermed  and Tade . . . Text, id. ib. No. 5.

Irterau , daughter of Ḥor  and Ta-amūn-neb . . . . Text, id. ib. No. 4.

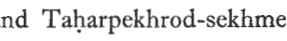
Irtubaste , daughter of Ptaḥemḥēt  and Taḥarpekhrod-sekhmet . Text, id. ib. No. 19.

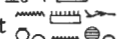

Naḥerḥu (?) . Text, id. ib. No. 13.

Nut-menkhet  (man). Text, id. ib. No. 12.

Pa-ḥaḥa . . . . Text, id. ib. No. 2.

Pedēsi. Text, id. ib. No. 3.

Penpa . . . . Text, id. ib. No. 14.

Tanefertiti , daughter of Ḥarwoz  and Neferēsi . Text, id. ib. No. 9.

Names lost, incomplete or left blank. Texts, id. ib. Nos. 1, 6, 8, 10, 11, 15, 16, 18.

Stelae.

Thoth and Khons(?), unscribed, Ptolemaic, found in 1928, in Neuchâtel Mus. Eg. 383.

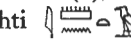
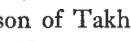
Amentanakhti , son of Takhit  (mother), Late Period. GARDINER MSS. photo. 28.380. Text, GUNN Notebook, 12, No. 105.

Haubaste(?) , daughter of Ptaḥardais . Late Period. Text, id. ib. No.

CONTENTS OF FASCICLE 1

PYRAMID-FIELD OF ŞAQQÂRA

I. PYRAMIDS

- A. Pyramid-complex of Teti, 393.
Pyramid-enclosure of Iput I, 396; of Khuit, 397.
- B. Pyramid-complex of Userkaf, 397.
- C. Step Pyramid enclosure of Neterikhet (Zoser), 399.
- D. Step Pyramid enclosure of Sekhemkhet, 415.
- E. 'Great Enclosure', 417.
- F. Pyramid-complex of Unis, 417.
- G. Pyramid-complex of Pepy I, 422.
- H. Pyramid-complex of Isesi, 424.
Pyramid-enclosure probably of wife of Isesi, 424.
- I. Pyramid-complex of Merenrē^c I, 425.
- J. Pyramid of Kakerē^c Ibi, 425.
- K. Pyramid-complex of Pepy II, 425.
Pyramid-enclosure of Neit, 431; of Iput II, 432; of
Wezebtan, 432.
- L. Burial-complex of Shepseskaf, 433.
- M. Pyramid-enclosure of Userkarē^c Khenzer, 434.
- N. Pyramid-enclosure of Dynasty XIII, 435.

II. NECROPOLIS

- A. North of the Step Pyramid
Early Dynastic cemetery west of village of Abûşîr, 435; north and north-west of the Serapeum, 436. Early Dynastic and Old Kingdom tombs (S 2146-3518), 436. Old Kingdom tombs Nos. 1-88 of Mariette, 448. Other numbered Old Kingdom tombs, 490. Unnumbered Early Dynastic and Old Kingdom tombs, 499. Late Period, Ptolemaic and Roman tombs, 503. Finds, 505.
- B. Around Teti Pyramid
North of the Pyramid, 508; east and south-east, 558; west and south-west, 565. Firth excavation, exact location or provenance unknown, 566.

C. EAST OF THE STEP PYRAMID

Map LVIII

(a) OLD KINGDOM

POSITION KNOWN

LS 17 [H 2]. MANŪFER , Supervisor of prophets of the Pyramid of Zadkarēc (Isesi), Inspector of prophets of Ptaḥ, Inspector of King's hair-dressers, etc. End of Dyn. V or early Dyn. VI.

Plan LIX.

L. *D. Text*, i, pp. 170-2, with plans; CHAMPOLLION (ed. HARTLEBEN) in *Bibl. Ég.* xxxi, pp. 108-12, with sketch-plan of part on p. 108. Plans of parts, *id. Not. descr.* ii, p. 483 [upper]; with sections, L. *D.* i. 39; PRISSE, *L'Art ég.* i, 7th pl. 'Tombeaux . . . Memphis' [ii].

Court.

(1) Men bringing bulls (lost except for block with two bulls with numbers, in Berlin/East Mus. 1115), and female offering-bringers (block with two formerly in Berlin Mus. 1135, now in Portugal).

Twelve offering-bringers, CHAMP., *Mon.* ccccv bis; nine, ROSELLINI, *Mon. Civ.* lxxxii [1-9]. Berlin (East) Mus. 1115, CHAMP., *Mon.* ccccviii [4]; ROSELLINI, *Mon. Civ.* xxvii [4, 5]; one bull, CAILLAUD, *Arts et Métiers*, pl. 34A [5]; text on one, *Aeg. Inschr.* i, p. 5; see *Ausf. Verz.* pp. 53-4. Block formerly in Berlin Mus. 1135; names and titles, *Aeg. Inschr.* i, p. 5; see *Ausf. Verz.* p. 54.

Hall. In Berlin (East) Mus. 1108.

Texts, *Aeg. Inschr.* i, pp. 101-18. See *Ausf. Verz.* pp. 51-3, with plan.

(2) [1st ed. 2, 3] Doorway. (a) and (b) Four registers of offering-bringers (parts of (a) sketched only and (b) almost completely lost).

(a) L. *D.* ii. 65 [left]; AMÉLINEAU, *Hist. sépulture*, ii, fig. on p. 363 (from squeeze by Nestor l'Hôte); NESTOR L'HÔTE MSS. 20406 'Tombeau de Manofre I', 1 (squeeze). I (sketched only), PRISSE, *L'Art ég. Texte*, fig. on p. 123. 1st offering-bringer in II, SCHÄFER in *Die Antike*, iii (1927), Abb. 81, p. 263 (repr. in *Ägyptische und heutige Kunst*, Abb. 81, p. 77).

(b) Remains of offering-bringers, L. *D.* ii. 66 [right].

(3) [1st ed. 7] (parts painted only) Registers, I and left part of II, cooking, right part of II, and III and V, tending cattle, IV and VI, offering-bringers with milk-jars, VII, butchers.

Id. ib. 66 [left]. Cooking in I and II, CHAMP., *Mon.* ccccxviii [3, 5]; in II, ROSELLINI, *Mon. Civ.* lxxxiv [4]. Milking cow, on left in III, id. ib. xxvii [2]; CHAMP., *Mon.* ccccviii [2]; another, PIRENNE, *Hist. civ.* i, pl. 83 between pp. 260-1; text above cow, MARIETTE, *Mastabas*, p. 447 [lower left]; NESTOR L'HÔTE MSS. 20396, 354 verso. V-VII, WRESZ., *Atlas*, i. 381. VII, CHAMP., *Mon.* ccccvii [4, 5]; EGGBRECHT, *Schlachtungsbräuche im Alten Ägypten* [etc.], Taf. v [A], pp. 208-9 [e]; 1st group of butchers, ROSELLINI, *Mon. Civ.* lxxxiii [A, 13-14]; CAPART, *Memphis*, fig. 315; 2nd group, LANGE, *Lebensbilder*, Abb. 7.

(4) Upper part, deceased at table, with offering-list and offerings. Lower part, deceased, and registers, **I**, bringing wild animals, **II-III**, bringing bulls, **IV**, cranes, and two sub-registers of fowl.

L. D. ii. 69, 70.

Lower part, *Aeg. und Vorderasiat. Alterthümer*, Taf. 93-4. Deceased, and right part of **I-IV**, BREASTED in *A. J. S. L.* xxxii (July 1916), fig. 1 on p. 232. Foot of deceased, SCHÄFER, *Von äg. Kunst* (1919), Taf. 41 [6]; (1922 and 1930), Taf. 38 [7]; (1963), Taf. 43 [2]; Eng. ed. *Principles of Egyptian Art*, pl. 74. **I-IV**, WRESZ., *Atlas*, i. 67 [a]. Right part of **I-III**, CAPART, *Memphis*, fig. 236; STEINDORFF, *Kunst*, 197; of **I-IV**, BREASTED, *History*, fig. 56. **I**, ROSELLINI, *Mon. Civ.* xviii; CHAMP., *Mon.* ccccv [4], ccccxvi; omitting man with hares, and gazelle, NESTOR L'HÔTE MSS. 20406 'Tombeau de Manofre I', 3, 8 (squeezes). **II**, scribe and men with 1st to 4th bulls, id. ib. 4, 5 (squeezes); man and 4th and 5th bulls, ROSELLINI, *Mon. Civ.* xxviii [1]; CHAMP., *Mon.* ccccviii [3]. Scribes and men with 1st bull, in **II** and **III**, DÜRST, *Die Rinder von Babylonien, Assyrien und Ägypten* [etc.], Taf. i [3]. **III**, scribe and man behind him, WOLF, *Kunst*, Abb. 232; PIRENNE, *Hist. civ.* i, pl. 42 between pp. 140-1; scribe, SCHÄFER in *Die Antike*, iii (1927), Abb. 58, p. 234 (repr. in *Ägyptische und heutige Kunst*, Abb. 58, p. 48); id. *Von äg. Kunst* (1919 and 1963), Taf. 14 [1]; (1922 and 1930), Taf. 13 [1]; Eng. ed. *Principles of Egyptian Art*, pl. 23; EKSCHEMITT, *Das Gedächtnis der Völker*, Abb. on p. 117; WRESZ., *Atlas*, iii, Textabb. 19,4 on p. 31; men with 2nd bull, and fowl below, *Ausf. Verz.* Abb. 6 on p. 52; front part of 4th bull, SACHS, *Die Musikinstrumente des alten Ägyptens*, Abb. 16, p. 24. **IV**, WRESZ., *Atlas*, iii. 83 [B]. Different species of birds in **IV**, ROSELLINI, *Mon. Civ.* xii; CHAMP., *Mon.* ccccv, ccccxix [1-4]; cranes, WILKINSON, *M. and C.* iii. 50 (No. 340,16,17) = ed. BIRCH, ii. 113 (No. 369,16,17) (corrected drawings); WEIGALL, *Anc. Eg. . . . Art*, 68 [lower]; FECHHEIMER, *Plastik* (1914), Taf. 129; (1923), Taf. 139; RANKE, *The Art of Ancient Egypt*, and BREASTED, *Geschichte Aegyptens* (1936), 214; MURRAY, *Sculpture*, pl. xiv [1]; PIJOÁN, *Summa Artis*, iii (1945), fig. 208; BYVANCK, *De Kunst*, pl. xxiii [85]; DONADONI, *Arte Egizia*, fig. 49 (as Ty); POSENER, SAUNERON and YOYOTTE, *Dict. civ.* fig. on p. 197 [lower]; PIRENNE, *Hist. civ.* i, pl. 53 [upper] facing p. 164; ZALOSKER in *Alte und moderne Kunst*, 20 [140] (1975), Abb. 12 (as Deir el-Bahri), p. 29; WILKINSON MSS. ii. 29 [middle right] (corrected drawing); three *smn*-geese, KUENTZ, *L'Oie du Nil*, fig. 2, p. 4 [1]; three birds, NESTOR L'HÔTE MSS. 20406 'Tombeau de Manofre I', 6 (squeeze).

(5) [1st ed. 6] Upper part, deceased at table, with offering-list and offerings. Lower part, deceased, and registers, **I-III**, offering-bringers, **IV**, butchers.

L. D. ii. 67-8.

Upper part. Offering-list, DÜMICHEN, *Grabpalast*, i, Taf. xviii-xxvi [d]. Some offerings, SCHÄFER, *Von äg. Kunst* (1930), Taf. 46 [2]; (1963), Taf. 20 [2]; Eng. ed. *Principles of Egyptian Art*, pl. 35.

Lower part. End of text before deceased, MARIETTE, *Mastabas*, p. 447 [lower right]. Three offering-bringers, possibly from here, CHAMP., *Mon.* ccccviii [1]; ROSELLINI, *Mon. Civ.* lxxxvii [2]. **I**, 2nd to 4th, and 7th to 9th offering-bringers, *Ägyptisches Museum 1823-1973*, Abb. 2. **III-IV**, incomplete, FECHHEIMER, *Plastik* (1914), Taf. 127-8; (1923), Taf. 137-8. Offering-bringer with calf, from **III**, PIRENNE, *Hist. civ.* i, pl. 70 between pp. 212-13. **IV**, EGGBRECHT, *Schlachtungsbräuche im Alten Ägypten* [etc.], Taf. v [B, C], pp. 208-9 [e]; omitting first two men carrying haunches, CHAMP., *Mon.* ccccvii [1-3]; ROSELLINI, *Mon. Civ.* lxxxiii [A, 1-12]. One man with haunch, and two groups of butchers, NESTOR L'HÔTE MSS. 20406 'Tombeau de Manofre I', 2 (squeeze).

(6) [1st ed. 5] False-door, with three identical masons' graffiti.



L. D. ii. 65 [left upper and right]; *Aeg. und Vorderasiat. Alterthümer*, on Taf. 92; MARIETTE, *Mastabas*, pp. 446-7 [upper]; MEYER, *Aegypten zur Zeit der Pyramidenerbauer*, on Taf. 4; SCHÄFER, *Äg. Kunst*, fig. on p. 8 [8]; id. and ANDRAE, *Kunst* (1925), 214; (1930 and 1942), 222; ERMAN, *Die Welt am Nil*, Taf. 16; id. *L'Égypte des Pharaons*, pl. vi; NESTOR L'HÔTE MSS. 20396, 354. Graffiti, *Aeg. Inschr.* i, pp. 104 [upper], cf. 102-3 [iv, viii]; cf. JUNKER, *Giza*, viii, pp. 59-60 with Abb. 23.

D 46. SETHU , King's son of his body, Count in Nekhen, Prophet of Nekhbet, etc. Dyn. V or later.

MARIETTE, *Mastabas*, pp. 302-4, with plan of chapel.

South false-door. Remains of titles, id. ib. p. 303.



Lower part of north false-door of Nefertememsaf , Secretary of Upper and Lower Egypt, Prophet of Neith, Director of the *d:t*-bark of Nemti, etc., Middle Kingdom. Two titles, see FISCHER in *Ä.Z.* 86 (1961), p. 24 [bottom] with note 6. See SMITH (W. S.) in REISNER, *Tomb Development*, p. 409.

D 48. NIKAANKH  , Prophet of Rē^c and Ḥathor in the Sun-temple of Neferirkarē, Inspector of *wac*b-priests, (a) of Rē^c in the Sun-temple of Userkaf, (b) of the Pyramid of Userkaf, etc. Temp. Neferirkarē or later.

MARIETTE, *Mastabas*, pp. 310-11, with plan of chapel; PETRIE (H.) and MURRAY, *Seven Memphite Tomb Chapels*, pp. 5-7, with plan, pl. xix [12(2)].

Panel, lower lintel and drum of false-door, id. ib. pl. iii [middle and bottom], cf. xviii [5], pp. 6 [23], 17-18 [87].

Lintel of doorway of offering-room, with offering-text, in Brit. Mus. 1275. MARIETTE, op. cit. pp. 310-11 [c]; *Hiero. Texts*, i, pl. 28 [52]; i², pl. xxi [1], p. 20.

D 45. PERSON  , Overseer of oils of the King's adorners, Overseer of the two *is*-chambers of the King's adorners of the Great House, etc. Temp. Saḥurē^c.



Wife, Khenut  , Prophetess of Ḥathor, etc.

MARIETTE, *Mastabas*, pp. 299-301, with some texts and plan; PETRIE (H.) and MURRAY, *Seven Memphite Tomb Chapels*, pp. 8-10, with plan, pl. xix [12(4)]. See DE ROUGÉ, *Recherches sur les monuments* [etc.] (1866), pp. 53-4 (repr. in *Bibl. Ég.* xxvi, pp. 52-3).

Offering-room.

South wall. Deceased at table, and four registers of offering-bringers and [butchers].

PETRIE (H.) and MURRAY, op. cit. pl. x [top and middle], pp. 9-10 [42], 21-2 [95].

North wall. Deceased seated, and registers. **I**, female dancers and clappers, **II**, family, text concerning bringing offerings from the chapel of Neferhetpes  , King's mother (of Userkaf), and man with yoke, in Berlin (East) Mus. 15004. **III**, estates.

I-II, MARBURG INST. photos. 67540-2; omitting right end, FECHHEIMER, *Plastik* (1914), Taf. 116; (1923), Taf. 126; man with yoke, SCHÄFER, *Von äg. Kunst* (1919), Taf. 16 [1]; (1922 and 1930), Taf. 15 [1]; (1963), Taf. 19 [1]; Eng. ed. *Principles of Egyptian Art*, pl. 32;

id. and ANDRAE, *Kunst* (1925), 255 [left]; (1930 and 1942), 267 [left]; RANKE, *The Art of Ancient Egypt*, and BREASTED, *Geschichte Aegyptens* (1936), 203; RAGAI, *L'Art*, pl. 11 [26]; HAMANN, *Äg. Kunst*, Abb. 17; upper part, SPIEGELBERG in *Ä.Z.* 54 (1918), Abb. 3, p. 68; texts, *Aeg. Inschr.* i, pp. 20-2; some names and titles, DE ROUGÉ, *Inscr. hiéro.* pl. lxxviii [middle]; text concerning bringing offerings, SETHE, *Urk.* i. 37 [25]. **III**, PETRIE (H.) and MURRAY, op. cit. pl. x [bottom], pp. 9 [41], 21 [94]; names of estates, JACQUET-GORDON, *Domaines*, pp. 334-6 [7S5], cf. figs. 120-1; of Nos. 1-4 (of JACQUET-GORDON), DE ROUGÉ, op. cit. pl. lxxviii [near bottom].

West wall. False-door, with family on jambs, top destroyed.

PETRIE (H.) and MURRAY, op. cit. pl. ix, cf. xxii [27], pp. 9 [40], 20-1 [93]. Two titles of deceased, and some names and titles of relatives, DE ROUGÉ, op. cit. pls. lxxviii [bottom], xcvi [lower].

Block with hippopotamus; PETRIE (H.) and MURRAY, op. cit. pl. viii [middle], pp. 9 [41], 20 [92].

D 49. KHNEMHOTP , Inspector of *warb*-priests in the Sun-temple of Userkaf, Prophet of Ḥathor foremost of the Pyramid of Userkaf, Overseer of the *nehet*-sanctuary of the *mert* of Ḥathor, etc. Dyn. V.

Wife, Khentetka  Ḥ, Prophetess of Ḥathor.

MARIETTE, *Mastabas*, pp. 311-12, with plan of chapel; PETRIE (H.) and MURRAY, *Seven Memphite Tomb Chapels*, pp. 14-16 [7], with plan of chapel, pls. xix [12(7)], xxv [45], and position, on pl. xxvii. Names and titles, LIEBLEIN, *Dict.* No. 20.

Chapel.

Doorway. Lintel with titles, PETRIE (H.) and MURRAY, pl. xv [upper], pp. 15 [73, 78], 24 [100]; text, MARIETTE, op. cit. p. 312 [c].

East wall. Architrave with offering-list, PETRIE (H.) and MURRAY, op. cit. pl. xvii [1], p. 25 [103.1]; offering-list, DÜMICHEN, *Grabpalast*, i, Taf. xviii-xxvi [a]; HASSAN, *Giza*, vi [2], pls. xvii-xxiv [25], p. 120.

South wall. Upper part, remains of donkeys threshing, men pulling flax and ploughing. Lower part, rowing-boats and sailing-boats. PETRIE (H.) and MURRAY, op. cit. pl. xvii [2, 4-7], pp. 15-16 [81], 25-6 [104.2, 106.4-109.7].

West wall. False-door. Panel, deceased at table, and offering-list, with man with linen and another censing on left, in Cairo Mus. CG 1423, BORCHARDT, *Denkmäler*, i, Bl. 23, pp. 103-4; PETRIE (H.) and MURRAY, op. cit. pl. xvi, pp. 16 [84], 25 [102]; offering-list, DÜMICHEN, op. cit. i, Taf. xviii-xxvi [b]; HASSAN, op. cit. pls. xvii-xxiv [26, 27], p. 120 (as CG 1433). Upper part, in Brit. Mus. 1143, *Hiero. Texts*, i, pl. 26 [51]; i², pl. xviii [2], p. 18; see *Guide (Sculpture)*, p. 18 [51]. Lower part, with deceased on jambs, and deceased, wife, son and attendants on walls on either side (only bottom of scene on right), PETRIE (H.) and MURRAY, op. cit. pl. xv [lower], pp. 15 [75], 24-5 [101]. Deceased, wife and attendants, from right of false-door, in Berlin Mus. 14099, FECHHEIMER, *Plastik* (1914), Taf. 108; (1923), Taf. 118; text, *Aeg. Inschr.* i, p. 15; name and title of wife, DE ROUGÉ, *Inscr. hiéro.* pl. lxxxii [lower right]; see *Ausf. Verz.* p. 56. Titles from false-door, MARIETTE, op. cit. p. 312 [d, upper]; DE ROUGÉ, *Inscr. hiéro.* pl. lxxxii [lower, left and middle]; id. *Recherches sur les monuments* [etc.] (1866), pp. 79-80 (repr. in *Bibl. Ég.* xxvi, pp. 76-7).

Blocks.

Fragments, including offering-list, offerings, deceased in palanquin, dancers, and clappers. PETRIE (H.) and MURRAY, op. cit. pl. xvii [3(1-3, 9-20)], pp. 16 [82], 25-6 [105.3].

Two blocks with wife and children, in Basel, Mus. für Völkerkunde, III. 5219, and Brit. Mus. 872, Moss in *Ä.Z.* 99 (1972-3), Taf. vi, p. 128. Basel block, STAEHELIN in *So lebten die Alten Ägypter* (Sonderausstellung 1976-7), fig. 6 on p. 19; *Geschenk des Nils. Ägyptische Kunstwerke aus schweizer Besitz* (Eine Ausstellung des Ägyptologischen Seminars der Universität Basel, 1978), No. 119 with pl.; see RÜTIMEYER, *Führer durch das Museum für Völkerkunde Basel, Alt-Ägypten* (1930), p. 17; id. *Bericht* (1921) in *Verhandlungen der Naturforschenden Gesellschaft in Basel*, xxxiii, p. 3. Brit. Mus. block, *Hiero. Texts*, i², pl. xx [1], p. 19. Names and titles, DE ROUGÉ, *Inscr. hiéro.* pl. lxxxiii [lower, 1st and 2nd lines]; MARIETTE, op. cit. p. 312 [d, lower].

Deceased at table, in Brit. Mus. 1166. *Hiero. Texts*, i, pl. 26 [61]; i², pl. xviii [1], p. 17; see *Guide (Sculpture)*, p. 19 [61].

Netting fowl, in Berlin (East) Mus. 14100. MARBURG photo. 67537; text, *Aeg. Inscr.* i, p. 15; see *Ausf. Verz.* p. 56.

Hippopotamus-hunt, in Berlin (East) Mus. 14101. WRESZ., *Atlas*, iii. 104A; ichneumon, CAPART, *Memphis*, fig. 379; SPIEGEL, *Hochkultur*, Taf. 62 [a]; PIRENNE, *Hist. civ.* i, pls. 54-5 between pp. 164-5; see *Ausf. Verz.* p. 56. Fragments of same scene, PETRIE (H.) and MURRAY, op. cit. pl. xvii [3(4-8)].

Fragments of lintel(?) with name and titles, in Bonn, Äg. Seminar der Universität, 118.

Offering-tables. In Cairo Museum.

Deceased, JE 15214. Wife, probably from here, CG 1367; see BORCHARDT, *Denkmäler*, i, pp. 30-1 (text).

LS 22 [C 11]. IYZEFA , Royal chamberlain, Prophet of Horus of Mesen, Director of bowmen, etc. Probably early Dyn. V.

L. *D. Text*, i, pp. 174-5, with plan of chapel; MARIETTE, *Mastabas*, pp. 132-4, with plan of chapel.

South Room.

Sketch of west wall with masons' marks, L. *D. Text*, i, p. 176.

North Room.

South wall. Bottom register of offering-bringers, L. *D.* ii. 100 [a], *Text*, i, fig. on p. 175.

North wall. Remains of two registers of butchers, L. *D. Ergänzt.* xxix [b].

West wall. Lower part of false-door, L. *D.* ii. 101 [a], *Text*, i, fig. on p. 174; inner jambs and upper part of right outer jamb, MARIETTE, op. cit. pp. 133-4.

D 57. KAPUINPU , Judge and Boundary official, Secretary of all commands of the King, etc. Dyn. VI.

MARIETTE, *Mastabas*, p. 330, with plan of chapel; PETRIE (H.) and MURRAY, *Seven Memphite Tomb Chapels*, pp. 10-13 [5], with plan, pl. xxii [31].

South chapel.

Remains of false-door. Id. ib. pl. xi [top and right], cf. xxiii [33-4], pp. 11 [50], 22 [96]; texts of lower lintel and drum, MARIETTE, op. cit. p. 330 [c, d].

North chapel.

Doorway. Fragments of lintel with offering-text, PETRIE (H.) and MURRAY, op. cit. pl. xi [middle left], cf. xxiii [38], pp. 11 [53], 22 [97, F].

North and south walls. Deceased at table, offerings, and remains of three registers of offering-bringers below. Id. ib. pl. xiii, pp. 11 [56], 22-3 [98].

POSITION UNKNOWN

D 47. NENKHEFTKA , *wacb*-priest of Rē^c in the Sun-temple of Userkaf, Inspector of *wacb*-priests of the Pyramid of Userkaf, *wacb*-priest of the Pyramid of Saḥurē^c, etc. Temp. Saḥurē^c or later.

Plan LIX.

Wife, Neferhetpes , Prophetess of Neith North of the Wall and Ḥaḥḥor Mistress of the Sycamore, etc.

MARIETTE, *Mastabas*, pp. 304-9, with plan of chapel on p. 304. Titles, DE ROUGÉ, *Recherches sur les monuments* [etc.] (1866), pp. 82-3 (repr. in *Bibl. Ég.* xxvi, pp. 79-80).

Offering-room.

(1) [1st ed. 1-3] Doorway. (a) and (b) Deceased with sons Ḳednas  at (a) and Nenkheftka at (b), and two registers of offering-bringers below. (c) Drum with name and titles.

Texts, MARIETTE, op. cit. p. 305 [c, d].

(2) [1st ed. 4] Registers of estates and offering-bringers.

Text and names of estates, id. ib. p. 305 [e, 'à droite']. Names of estates, JACQUET-GORDON, *Domaines*, pp. 340-2 [9S5], Nos. 9-14, cf. figs. 124, 125 [b] (differently placed).

(3) [1st ed. 5] Registers, I-II, estates, III-IV, attendants, in Cairo Mus. CG 1558.

BORCHARDT, *Denkmäler*, ii, Bl. 62 (caption interchanged with 1559), pp. 19-21; WRESZ., *Atlas*, i. 408. Names of estates, JACQUET-GORDON, op. cit. pp. 340-1 [9S5], Nos. 1-8, cf. figs. 124, 125 [a] (differently placed). Upper parts of two men in the middle of III, FORMAN (W. and B.) and VILÍMKOVÁ, *Eg. Art*, pl. 18. Woman with fan in IV, LEBOVITCH in *Ann. Serv.* xxxix (1939), fig. 6, pp. 151-2; WENIG, *Die Frau*, pl. 13. Texts, MARIETTE, op. cit. pp. 305-6 [e, 'à gauche']. See MASPERO, *Guide*, p. 87 [233B].

(4) [1st ed. 6] Deceased at table, and below, registers with musicians, singers, dancers, and clappers, in Cairo Mus. CG 1533. Offering-bringers below.

Cairo Mus. CG 1533. BORCHARDT, *Denkmäler*, i, Bl. 47, pp. 231-2; MASPERO, *L'Arch. ég.* (1907), fig. 131; id. in GRÉBAUT, *Le Musée Égyptien*, i, pl. xxvi, p. 25; QUIBELL (A. A.), *Egyptian History and Art*, pl. v; LEBOVITCH, *Anc. Eg.* pl. xii [63]; MITRY, *Illus. Cat.* No. 233; RIESTERER, *Kunstschätze . . . Kairo*, pl. 17; HICKMANN, *45 Siècles*, pl. lx; id. in *Ä.Z.* 83 (1958), Taf. xi [a], pp. 110, 121-4. Omitting deceased, id. *Ägypten*, Abb. 4-6; WRESZ., *Atlas*, i. 407; POULSEN (F.), *Ägyptens Kunst* (1933), fig. 45; CAPART, *Memphis*, fig. 174; MONTET, *Scènes*, pl. xxiv [2] (as 1534); RANKE, *The Art of Ancient Egypt*, and BREASTED, *Geschichte Aegyptens* (1936), 201; GALASSI, *Tehenu*, fig. 111; LEBOVITCH in *J.E.A.* 46 (1960), fig. 1, p. 54. Musicians, FORMAN (W. and B.) and VILÍMKOVÁ, *Eg. Art*, pl. 27; SHURINOVA,

Iskusstvo Drevnego Egipta, pl. 20. Two flutists and two singers, CASSON, *Ancient Egypt*, fig. on p. 113 [upper]. Flutist and singer, SPIEGEL, *Hochkultur*, Taf. 53 [b]; BRUNNER-TRAUT, *Die Alten Ägypter*, Taf. 31b. Two singers, SMITH, *Hist. Eg. Sculp.* figs. 127a [left], 179 [left], pp. 284, 314-15. Harpist, two singers, clappers, and two dancers, DONADONI, *Egyptian Museum Cairo*, pl. on p. 60; *Great Museums*, fig. on p. 229 [8]. Flutist, harpist, two singers, four dancers, and two clappers, SAMEH, *Daily Life*, figs. on pp. 128-9. Dancers and clappers, GALASSI in *Rivista dell'Istituto Nazionale d'Archeologia e Storia dell'Arte*, N.S. iv (1955), fig. 21 on p. 21. See MASPERO, *Guide*, p. 87 [233A].

Texts of offering-bringers, MARIETTE, op. cit. p. 306 [bottom].

(5) [1st ed. 8] Offering-bringers, butchers and rowing-boat. Texts, id. ib. p. 306 [middle].

(6) [1st ed. 7] False-door, in Cairo Mus. CG 1484.

Id. ib. pp. 307-9; BORCHARDT, *Denkmäler*, i, Bl. 40, pp. 177-81; MASPERO, *Égypte*, fig. 64; id. in GRÉBAUT, *Le Musée Égyptien*, i, pl. xxiii, pp. 21-2; VANDIER, *Manuel*, ii, fig. 280 [upper left]. Some texts, DE ROUGÉ, *Inscr. hiéro.* pls. lxxxii [upper], lxxxiii [upper]. See MASPERO, *Guide*, p. 27 [35].

Statues. In Cairo Museum. See MARIETTE, op. cit. p. 307 [f] (mention of two).

Deceased. Seated, with wife, both headless, double-stature, CG 94, 285; BORCHARDT, *Statuen*, i, Bl. 21 (CG 94), pp. 74, 177. Standing, fragments, CG 284; text, id. ib. p. 176. Two, seated, diorite, CG 30-1; id. ib. Bl. 8, pp. 30-1. Three, seated, headless, one limestone and two granite, CG 69, 174, JE 35312; texts of CG 69, 174, id. ib. pp. 59, 122. Seated, upper part lost, granite, CG 178; text, id. ib. p. 124. Seated, head and fragments, CG 263, 265-6; head (CG 263), PRISSE, *L'Art ég.* ii, *Sculpture*, 33rd pl. [3], 'Fragments de statues iconiques'; BORCHARDT, *Statuen*, i, Bl. 57, p. 168; CG 265-6, see pp. 168-9 (text). Two, scribe-statues, headless, limestone and granite, CG 103, 170; id. ib. Bl. 38 (CG 170), pp. 81, 120.

Fragments of servant-statuettes, CG 321-3; texts, id. ib. pp. 186-7.

D 50. NIKAURĒ , Inspector of singers of the Pyramid of Userkaf, Prophet of Userkaf and Raḥneferet, etc. Temp. Raḥneferet or later.

MARIETTE, *Mastabas*, p. 313, with plan of chapel.

False-door, in Cairo Mus. CG 57173. Name and titles, id. ib. p. 313 [c]. Offering-list, HASSAN, *Giza*, vi [2], pls. lxxv-lxxii [72], p. 133. See MASPERO, *Guide*, p. 89 [241]; ENGELBACH in *Ann. Serv.* xxxiv (1934), p. 158 with note 1.

D 51. PTAḤḤOTP , (a) Prophet of Rē in the Sun-temple, (b) King's *warc*-priest of the *mert*, and (c) Prophet, all of Userkaf, etc. Temp. Userkaf or later.

Wife, Khentkaus , Royal acquaintance.

MARIETTE, *Mastabas*, pp. 314-16, with plan of chapel.

Name and title on drum of doorway, id. ib. p. 314 [c].

Deceased and family, with butchers and offering-bringers, in Passage. Names and titles, id. ib. pp. 314-15 [d].

False-door, in Offering-room. Names and titles, id. ib. p. 316 [e].

Finds

Lower part of seated statue, formerly in Huber Colln., now in Cairo Mus. CG 156. Sketch and text, BRUGSCH, *Recueil*, pl. vii [3], p. 13; WILKINSON MSS. xiii. 70; text, BORCHARDT, *Statuen*, i, p. 113; DE ROUGÉ, *Inscr. hiéro.* pl. ccci [1].

D 52. SENENU^cANKH $\downarrow \overline{\text{O}}$ 𓂏 𓂐 , Prophet of the Sun-temple of Userkaf, *warb*-priest of the Pyramid of Saḥurē^c, Inspector of scribes of petitions, etc. Temp. Saḥurē^c or later, or Dyn. VI (Baer).

Plan LIX.

MARIETTE, *Mastabas*, pp. 316–21, with plan of chapel on p. 316.

Passage.

(1) Men bringing animals to deceased and scribes. Texts, id. ib. p. 317 [middle].

(2) Deceased seated, and estates.

Texts, id. ib. p. 317 [top]. Short text, id. in *Rev. Arch.* n.s. xix (1869), pl. iii [b, 1st column] facing p. 82. Names of estates, JACQUET-GORDON, *Domaines*, pp. 337–9 [8S5], cf. figs. 122–3.

(3) Boats. See MARIETTE, *Mastabas*, p. 319 [middle].

(4) False-door. Fragment of right jamb in Berlin (East) Mus. 7728.

Id. ib. pp. 319 [bottom]–320 (with sketch-plan), cf. 319 [top]. Berlin (East) Mus. 7728; text, *Aeg. Inscr.* i, p. 40; see *Ausf. Verz.* p. 60.

(5) Two adjoining blocks from above niche, (a) lower part of deceased at table, (b) three remaining registers of offering-bringers and butchers, both in Cairo Mus. CG 1554.

BORCHARDT, *Denkmäler*, ii. Bl. 59 (block b), pp. 14–15. (b) Two bottom registers, PERROT and CHIPIEZ, *Hist. de l'Art*, i, fig. 91; texts, ČERNÝ Notebook, 118, pp. 90–1; three names, MARIETTE, *Mastabas*, p. 318 [bottom right]; see MASPERO, *Guide* (1914), p. 77 [after 234].

(6) [1st ed. 3] Upper part, will concerning *ka*-servants of the endowment. Lower part, deceased with son, and musicians and offering-bringers.

Texts, MARIETTE, *Mastabas*, pp. 317 [bottom], 318 [left]. Text of will, SETHE, *Urk.* i. 36–7 [24]; MORET in *Rec. Trav.* xxix (1907), pp. 91–4; GOEDICKE, *Rechtsinschriften*, Taf. viii, pp. 75–80.

Finds

Ointment-slab, alabaster, in Cairo Mus. CG 1337. BORCHARDT, *Denkmäler*, i, Bl. 6, p. 18; MARIETTE, *Mastabas*, fig. on p. 321; VASSALLI MSS. 95; text, DE ROUGÉ, *Inscr. hiéro.* pl. lii [top].

D 53. NEFERIRTPTAḤ \square 𓂏 𓂐 𓂑 𓂒 , Supervisor of prophets (a) of Rē^c in the Sun-temple of Menkauḥor, (b) of the Pyramid of Menkauḥor, Inspector of King's adorners of the Great House, etc. Temp. Menkauḥor or later.

MARIETTE, *Mastabas*, p. 322, with plan of chapel.

False-door. Name and titles from jambs, id. ib. p. 322.

D 54. PTAḤSHEPSES \square 𓂏 𓂐 𓂑 𓂒 , Inspector of prophets of Rē^c and Ḥathor in the Sun-temple of Neferirkarē^c, Judge and Inspector of book-keepers, etc. Temp. Neferirkarē^c or later.

MARIETTE, *Mastabas*, p. 323, with plan of chapel.

Lintel of false-door of north subsidiary niche with name and titles, id. ib. p. 323.

Statues, probably ascribed in error, see tomb No. 49 [C 10].

D 55. NEFERIRTNEF , Judge and Overseer of scribes, Prophet of Saḥurē, Prophet of Rē in the Sun-temples of Userkaf and Neferirkarē, etc. Temp. Neferirkarē or later.

Plan LIX.

Wife, Wethesetkaus , Prophetess of Ḥaṭhor Mistress of the Sycamore and Neith North of the Wall, etc.

Chapel. In Brussels, Mus. Roy. E.2465.

Description and texts, MARIETTE, *Mastabas*, pp. 324-8 (texts incomplete), with plan on p. 324; VAN DE WALLE, *Le Mastaba de Neferirtenef* [etc.] (hereafter *Neferirtenef*) (1930 and 1973), latter with plan. Texts, SPELEERS, *Rec. inscr.* pp. 8-12 [53], with plan showing position of scenes on p. 8 [top]. View, *Chron. d'Ég.* iii (1927-8), fig. on p. 223. To be completely published by VAN DE WALLE.

(1) [1st ed. 1, 2] Doorway. (a) and (b) Men dragging statue, and estates below.

Texts, MARIETTE, pp. 324-5 [d]; SPELEERS, p. 8 [i, ii]; VAN DE WALLE, *Neferirtenef* (1930), pp. 64-5. Names of estates, MARIETTE in *Rev. Arch.* n.s. xix (1869), pl. iv [c] facing p. 87; JACQUET-GORDON, *Domaines*, pp. 345-6 [1155].

(2) [1st ed. 3] Deceased, accompanied by family, spearing fish and fowling with throw-stick from canoe, and below, men netting and cutting open fish, baking, and netting fowl.

Deceased, CAPART, *Memphis*, fig. 242; id. *Paysage*, fig. 8; DE KEYSER in *Chron. d'Ég.* xxii (1947), fig. 8, p. 42; JUNKER, *Giza*, iv, Abb. 8a [1], p. 30; VAN DE WALLE, *Neferirtenef* (1930), pl. vi; (1973), fig. on p. 27. Frog on branch, KEIMER in *R.E.A.* ii (1929), fig. 2 [right], p. 211. Netting and cutting open fish, baking, and birds in net, VANDIER, *Manuel*, v, pls. xxxiv [243], xx [157,2], pp. 560 [29], 331 [24]. Texts, VAN DE WALLE, *Neferirtenef* (1930), pp. 61-3; some, SPELEERS, p. 11 [ix]; MARIETTE, p. 325 [middle upper].

(3) [1st ed. 4] Deceased at table, with offering-list, man censuring and another with fowl, and butchers.

VAN DE WALLE, *Neferirtenef* (1930), pl. v, pp. 67-71. Texts, SPELEERS, pp. 11-12 [x].

(4)-(6) [1st ed. 5-7] At top, list of oils and offering-text.

Text, id. ib. p. 8 [iii]; VAN DE WALLE, *Neferirtenef* (1930), pp. 43-4.

(4) and (5) [1st ed. 5 and 6] Two false-doors, with eight registers of offering-bringers on outer jambs.

VAN DE WALLE in *Bull. Soc. fr. d'Ég.* No. 69 (March 1974), fig. on p. 12 [left]. Offering-bringers in II-III on left outer jamb of (4), deceased and wife on left inner jamb and deceased at table on panel of (5), id. *Neferirtenef* (1973), figs. on pp. 15, 11, and front cover. Deceased and wife on left inner jamb of (5), CAPART, *Propos*, fig. 60; id. *L'Art ég.* iii, pl. 451; *Bruxelles. Mus. Roy. Département égyptien. Album* (1934), pl. 27; PIRENNE, *Hist. civ.* i, pl. 64 facing p. 189; *Bruxelles. Mus. Roy. Album* (1938), fig. 24; VAN OS in *Jaarbericht Ex Oriente Lux*, No. 8 (1942), pl. xxxix [1], p. 779. Head of deceased from right inner jamb of (5), VAN DE WALLE in *Bull. Soc. fr. d'Ég.* No. 69 (March 1974), fig. on p. 6; CAPART, *Documents*, i, pl. 17. Texts, VAN DE WALLE, *Neferirtenef* (1930), pp. 45-53; SPELEERS, p. 9 [iv, v]; some, MARIETTE, pp. 326, 327 [lower].

(6) [1st ed. 7] Deceased with family at table, and registers with offerings, players of *senet*-game (draughts), musicians, singer, and dancers.

VAN DE WALLE in *Bull. Soc. fr. d'Ég.* No. 69 (March 1974), figs. on pp. 9, 12 [right]. Players of *senet*-game, WRESZ., *Atlas*, iii, Textabb. 6,1 on p. 11. Musicians and dancers, VAN DE WALLE, *Neferirtenef* (1973), fig. on p. 19. Texts, id. ib. (1930), pp. 53-5; SPELEERS, p. 9 [vi]; some MARIETTE, p. 327 [upper].

(7) [1st ed. 8] Registers, I, catching birds, II, picking figs, III, picking grapes, IV, offering-bringers, V, men bringing animals.

II-III, WRESZ., *Atlas*, iii, 61; PAILLE in *Musées de France*, Oct. 1949, fig. 2 on p. 197. Men in two middle trees in II, *Chron. d'Ég.* v (1930), fig. 1, pp. 95-7. Two men in the middle in III, *Bruxelles. Mus. Roy. Département égyptien. Album* (1934), pl. 29. Two offering-bringers in IV, WRESZ., *Atlas*, iii, Textabb. 61 on p. 123. Texts, VAN DE WALLE, *Neferirtenef* (1930), p. 56; SPELEERS, p. 10 [vii].

(8) [1st ed. 9] Deceased and wife, with dwarf leading dog and monkey below, and registers of agriculture, I, clearing ground, with flutist, II, ploughing, sheep treading grain, and sowing, III, men tying up bundles and pulling flax, IV, reaping corn, V-VI, men with resonant sticks, donkeys transporting produce, men tying up sack with sheaves, and piling up sheaves, VII, winnowing, threshing with donkeys, and baking-scenes.

Dwarf with dog and monkey, *Bruxelles. Mus. Roy. Département égyptien. Album* (1934), pl. 28; PIRENNE, *Hist. civ.* i, pl. 96 facing p. 305; with man with laden donkey in VI, VAN DE WALLE in *Bull. Soc. fr. d'Ég.* No. 69 (March 1974), figs. on pp. 14, 17. II-III, WRESZ., *Atlas*, iii, 45. Reaper at right end of IV, KEIMER in *R.E.A.* ii (1929), fig. 2 [left], p. 211. V (omitting left end), WRESZ., op. cit. 56 [A]. Men with resonant sticks in V, HICKMANN, *45 Siècles*, pl. lxxviii [A]; id. *Égypten*, Abb. 46. Man with laden donkey in VI, CAPART, *Memphis*, fig. 176; id. *Documents*, i, pl. 23 [A]; *Bruxelles. Mus. Roy. d'Art et d'Histoire* (1958). *Antiquités, Extrême-Orient, Ethnographie*, No. 3 with pl.; MAZAR, *Views*, ii, pl. 184; VAN DE WALLE, *Neferirtenef* (1930), pl. iii. Threshing and baking, in VII, WRESZ., op. cit. 57 [A]; threshing, VAN DE WALLE, *Neferirtenef* (1930), pl. iv; (1973), fig. on p. 23; PIJOÁN, *Summa Artis*, iii, fig. 204; SPIEGEL, *Hochkultur*, Taf. 59 [b]; baking, MARIETTE, fig. on p. 328. Texts, SPELEERS, p. 10 [viii]; VAN DE WALLE, *Neferirtenef* (1930), pp. 57-60; some, MARIETTE, p. 325 [middle lower]; determinatives of Sun-temples, WRESZ., op. cit. Textabb. 58,2 on p. 115.

Statues. In Cairo Museum.

Deceased seated, with wife squatting and small son Werkauptah , CG 21. BORCHARDT, *Statuen*, i, Bl. 6, pp. 21-3; HORNEMANN, *Types*, v, pl. 1416; CAPART, *L'Art ég.* ii, pl. 261; VAN DE WALLE, *Neferirtenef* (1930), pls. i, ii. Upper part, id. ib. (1973), fig. on p. 7; CAPART, *Documents*, i, pl. 18.

Lower part of seated statue, CG 157. See BORCHARDT, op. cit. pp. 113-14 (text).

D 56. NIMACEṢED , Prophet of Rē and Hathor in the Sun-temple of Neferirkarē, Prophet of the Pyramids of Neferirkarē, Raṣneferef, and Neuserre, etc. Temp. Neuserre or later.

Block with name and titles, MARIETTE, *Mastabas*, p. 329.

Statues. In Cairo Museum.

Double-statue of deceased, CG 133. BORCHARDT, *Statuen*, i, Bl. 30, pp. 99-100; BOREUX

in *Mélanges Maspero*, i [2], pl. i [3], p. 807; SHOUKRY, *Privatgrabstatue*, Abb. 32; HORNE-MANN, *Types*, iv, pl. 1094; RIESTERER, *Kunstschätze . . . Kairo*, pl. 13. See MASPERO, *Guide*, p. 73 [164].

Scribe-statue of deceased, granite, CG 58. BORCHARDT, op. cit. Bl. 15, pp. 51-2; WEIGALL, *Anc. Eg. . . . Art*, 55; HORNEMANN, *Types*, ii, pl. 402; MASPERO, *Le Musée Égyptien*, ii, pl. xvii, pp. 47-8; id. *Égypte*, fig. 161; PETRIE GIZA photos. 519-20. See id. *Guide*, p. 71 [154].

Deceased, CG 88. BORCHARDT, op. cit. Bl. 20, pp. 69-70.

Man cleaning jar, probably from here, CG 113. Id. ib. Bl. 25, p. 88; MASPERO, *Hist. anc.* i, fig. on p. 406; id. *Égypte*, fig. 16; HORNEMANN, *Types*, ii, pl. 508; London. *5000 Years*, pl. xi, p. 15 [32]; Vienna. *5000 Jahre*, No. 41 with Abb.; Zürich. *5000 Jahre*, Abb. 33, p. 60 [124]; Brussels. *5000 ans*, fig. 99, Addenda, No. 17A; Amsterdam. *5000 jaar*, fig. 10 [30]. See BREASTED (Jr.), *Eg. Servant Statues*, p. 46 [Type 5,2].

D 58. RA^cNEFEREF^cANKH  ♀, Overlord of Nekheb, etc. Temp. Ra^cneferef or later.

MARIETTE, *Mastabas*, p. 335, with plan of chapel.

Name and titles from false-door, id. ib. p. 335.

Statue of man seated, probably from here, in Cairo Mus. CG 87. BORCHARDT, *Statuen*, i, Bl. 19, p. 69.

E 10. KEDNAS , Judge and Inspector of book-keepers, Prophet of the Pyramid of Menkauhor, etc. End of Dyn. V or later.

Rock-cut tomb with statues in niches.

MARIETTE, *Mastabas*, pp. 402-4, with plan of chapel on p. 403.

Offering-room.

West wall. Deceased at table, and false-door. Titles, id. ib. p. 403.

Other walls. Musicians, dancers, draughts-players, estates, agriculture, fishing, and fowling, see id. ib. p. 404.

E 11. NEFERSESHEM-SESHET  KHENU , King's son of his body, Chief Justice and Vizier, etc. Dynasty VI.

MARIETTE, *Mastabas*, pp. 405-11, with plan of chapel on p. 405.

Offering-niche. In Cairo Museum. See MASPERO, *Guide*, p. 31 [62].

South and north walls. Deceased at table, offering-list, and offering-bringers, CG 1491-2. BORCHARDT, *Denkmäler*, i, Bl. 42, pp. 192-8; offering-lists, HASSAN, *Giza*, vi [2], pls. lxxxi-lxxxviii [91-2], p. 139; some texts of offering-bringers, MARIETTE, op. cit. p. 406. CG 1492, texts above offering-bringers, id. in *Rev. Arch.* n.s. xix (1869), pls. iv [c, middle], iii [b, 4th col.] facing pp. 87, 82.

False-door, CG 1490. BORCHARDT, op. cit. Bl. 41, pp. 191-2; MARIETTE, *Mastabas*, pp. 407-10, with plan.



Perhaps from here. In Cairo Museum.

Blocks with offering-bringers, CG 1542, 1545, 1553, 1676. BORCHARDT, *op. cit.* ii, Bl. 53-4, 59, pp. 1-2, 4-5, 13-14, 130. CG 1545, 1553, MASPERO, *Le Musée Égyptien*, ii, pl. xi [middle and bottom], pp. 32-3; CAPART, *Rue de Tombeaux*, pl. ciii [middle and bottom].

E 12. KAPUINPU , Royal chamberlain, Director of the Broad Hall, Overseer of the Great Court, etc. Dyn. VI.

Plan, MARIETTE, *Mastabas*, p. 411.

Titles from false-door, *id. ib.* p. 416. (For the false-door on pp. 412-15, see tomb nos. 37-8 [E 1, 2].)

E 13. MERYRĒ-ANKH  IḤYNES , Overseer of all works of the King, Overseer of Ṭura quarries, etc. Temp. Pepy I or later.

False-door, in Cairo Mus. CG 1483. BORCHARDT, *Denkmäler*, i, Bl. 39, pp. 174-6; VANDIER, *Manuel*, ii, fig. 279 [lower left] on p. 409; titles, LIEBLEIN, *Dict.* No. 35; names, DE ROUGÉ, *Inscr. hiéro.* pl. iv [near top]; see MASPERO, *Guide*, p. 27 [37]; MARIETTE, *Mastabas*, p. 416.

F 1. NI-ANKHRĒ , Overseer of King's adorners, Inspector of King's hairdressers, Overseer of gold of the magazines in the Two Houses, etc. Dyn. V.

Wife, Ḥepetka , Royal acquaintance.

MARIETTE, *Mastabas*, pp. 431-2.

False-door. Panel, and lower part, in Brit. Mus. 1429, 658. *Hiero. Texts*, i, pl. 25; i², pl. xxvi, pp. 26-7. Texts, including some not on Brit. Mus. blocks, MARIETTE, *op. cit.* pp. 431-2. Brit. Mus. 658, see *Guide (Sculpture)*, p. 26 [83].

Statue, with small figures of wife squatting and son Inpukha^c (tomb, see *infra*) by his legs, in Cairo Mus. CG 62. BORCHARDT, *Statuen*, i, Bl. 16, pp. 54-5; HORNEMANN, *Types*, v, pl. 1410.

F 3. MINNŪFER , Elder of the house. Dyn. V-VI.

Wife, Ḥerḥerankh , *mitrt*.

False-door. Upper part and lintel with offering-text, in Cairo Mus. CG 1516, 1680; text of CG 1516, BORCHARDT, *Denkmäler*, i, pp. 219-20; of CG 1680, *id. ib.* ii, p. 132; MARIETTE, *Mastabas*, p. 457 [H 13, 1st object], cf. 433 [F 3]. Drum, and upper parts of jambs with names of sons, *id. ib.* fig. on p. 457 [H 13, 2nd object].

(b) LATE PERIOD

Including tombs farther east, in face of cliff



DOUBLE TOMB ABOVE MORTUARY TEMPLE OF USERKAF. Late Dyn. XXVI or early Dyn. XXVII.

Map LVIII.

LAUER in *Ann. Serv.* li (1951), pp. 470-84, with plan and views, pls. i, iii-v. See FIRTH in *ib.* xxix (1929), pp. 68-70.

Surface finds, probably all Dyn. XXVI. Inscribed fragments, LAUER, *op. cit.* pl. xvi [2], p. 470. Capital fragment with palm-leaf decoration, *id. ib.* pl. xvi [1], fig. 2, p. 470. Palm-capital fragment, *id. ib.* fig. 1, p. 470.

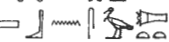

Vaulted tombs at bottom of shaft

(a) North tomb. NEFEREBRĒ^c-SINEIT , Royal chamberlain, etc., son of Merib  and Shepenubaste .

View with sarcophagus, *id. ib.* pl. ii; *id.* in *Bull. Soc. fr. d'Ég.* No. 9 (Feb. 1952), fig. 4, cf. 3, pp. 22-3. Coffin-texts and Pyramid-texts, DRIOTON in *Ann. Serv.* li (1951), pp. 486-9 [C].

Sarcophagi. Outer; text, *id. ib.* p. 485 [A]; cf. LAUER in *ib.* p. 473. Inner, anthropoid, in fragments; lid, *id. ib.* pls. vi, vii, p. 474, with text, DRIOTON in *ib.* p. 486 [B]; LECLANT in *Orientalia*, n.s. 21 (1952), pl. xxxiv [10], p. 239 [d]; see BUHL, *Sarcophagi*, p. 68 [E, a 28], with titles, on pl. iv.

Three canopic-jars, alabaster. LAUER, *op. cit.* pl. xiii [1], p. 475.

(b) South tomb. WEḤEBRĒ^c-MEN , Treasurer of the King of Lower Egypt, etc., son of Ta'a  (mother).





Hieratic texts on blocks. *Id. ib.* fig. 5, p. 479.

Outer sarcophagus; *id. ib.* pls. ix, x, xiv [1], p. 481; text, DRIOTON in *ib.* p. 490 (copied by Firth and Lauer). Inner anthropoid coffin, wood; LAUER, *op. cit.* pls. xiv [2], xv [1], pp. 481-2.

Four canopic-jars, alabaster, in Stockholm Mus. MM. 19233. *Id. ib.* pls. xii, xiii [2, 3], pp. 480-1.

Shaft at south-west corner.

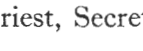
Jars with hieratic texts naming embalming materials, Late Period. *Id. ib.* liii (1956), pl. i, pp. 174-80.

HOR  NEFEREBRĒ^c-EMAKHET  (or WEḤEBRĒ^c-EMAKHET ) , God's father, *sem*-priest, Secretary of Ra-setau, etc. Temp. Apries or later.

Map LVIII.

Parents, Semtu-tefnakht  and Irterau .

SAAD in *Ann. Serv.* xli (1942), pp. 391-3, with views, pl. xxviii (= *id.* *Royal Excavations at Saqqara and Helwan* (1941-1945) in *Ann. Serv. Cahier*, 3 (1947), pp. 11-13 with pl. iii); SCHWEITZER in *Orientalia*, n.s. 17 (1948), p. 265 [middle]. Plans and sections, LAUER in *Ann. Serv.* lii (1954), pls. i, ii, pp. 133-6. Names and titles, DE MEULENAERE, *Le Surnom égyptien à la Basse Époque*, p. 17 [54].

Vaulted tomb at bottom of shaft.

Exterior walls. Pyramid-texts, offering-list, etc.; DRIOTON in *Ann. Serv.* lii (1954), pp. 122-5. View of south wall with offering-list, SAAD, *op. cit.* pl. xxx, p. 393 (= pl. v, p. 13).

Sarcophagus with Pyramid-texts. View, *id. ib.* pl. xxix, p. 391 (= pl. iv, p. 11). Texts, DRIOTON, *op. cit.* pp. 125-7.

ḤARKHEBI , Overseer of the chamber, Overseer of chamberlains of Per-wēr and Per-neser, etc. Dyn. XXVI.



Exact position unknown.



Parents, Pedeḥor and Tasent(ent)ḥor .

Anthropoid sarcophagus, basalt, in New York, M.M.A. 07.229.1. A. M. L[YTHGOE] in *M.M.A. Bull.* ii (1907), fig. 1, p. 194; *A Handbook of the Egyptian Rooms* (1911), fig. 70, pp. 169-70; BUHL, *Sarcophagi*, fig. 5, pp. 25-6 [A,7], cf. pl. i. Texts of lid, DARESSY in *Ann. Serv.* iv (1903), pp. 78-9.

Canopic-jars, in Cairo Mus. JE 35781. Texts, id. ib. p. 77.

Mummy-mask and ornaments, some inscribed, gilt silver, in Cairo Mus. CG 53779-80. Text, id. ib. p. 80; see VERNIER, *Bijoux et orfèvreries* (*Cat. Caire*), pp. 499-500.

LS 23. IRCAḤOR  NEFEREBRĒ^c-NŪFERⁱ , Overseer of the ante-chamber, etc. Temp. Necho II to Apries.

Parents, 'Ankh-ḥor  and Atemardais .

BRESCIANI and PERNIGOTTI, *La tomba di Horiraa* (in preparation); *L. D. Text*, i, pp. 175 (with plan), 177. Plan, *L. D.* iii. 280 [a].

Shaft.

Room A (of Lepsius).

North, south and west walls. Texts and scenes of Book of the Dead, id. ib. 280 [b, c], 281 [a].

Room B (of Lepsius).

South, east and west walls. Texts and divinities, id. ib. 281 [b, c], 282 [a].

Ceiling. Name and title, *L. D. Text*, i, p. 177.

Finds



Offering-table, basalt, in Louvre D 65 [E.3867]. DEVÉRIA squeezes, 6166, ii. 122; ARCHIVES phot. E. 704. Text, PIERRET, *Rec. inscr.* i, pp. 82-4. Offering-list, DÜMICHEN, *Grabpalast*, i, Taf. xviii-xxvi [r]. Names and titles, LIEBLEIN, *Dict.* No. 2393. See BOREUX, *Guide*, i, p. 123.

Offering-basin, granite, in Stockholm Mus. NME 43. PETERSON in *Orientalia Suecana*, xix-xx (1970-1), Abb. 13, pp. 18-19 [xxx]. Text, PIEHL, *Inscr. hiéro.* 1 Sér. xiv [G]; MOGENSEN, *Stèles égyptiennes au Musée National de Stockholm*, p. 73. See LIEBLEIN, *Katalog öfver egyptiska fornlemningar* (1868), p. 27 [43].

Canopic-jars, in Louvre. Texts of two, GOODWIN MSS. 31279, 2-3; of one, PIEHL, op. cit. xxvi [D]; of another, SETHE, *Zur Geschichte der Einbalsamierung* [etc.] in *Sitzungsb. Berlin* (1934), p. 16* [XX,C].

LS 24. BEKENRENEF , Vizier, etc. Temp. Psammetikhos I.

Plan LIX.

Parents, Pedeneit , Overseer of prophets, and Tageb .

Rock-cut tomb. Excavated by Bresciani for the University of Pisa since 1974.

¹ The good name does not occur in the tomb or on the monuments listed here.

L. *D. Text*, i, pp. 177–81, with plan and section on pp. 177, 181; QUIBELL in *Ann. Serv.* xi (1911), pp. 275–6, with plan on p. 275; BRESCIANI in *Bull. Soc. fr. d'Ég.* No. 76 (June 1976), pp. 5–8; ZIVIE in *Archéologia*, No. 79 (Feb. 1975), pp. 65–6, with sketch-plan (from LEPSIUS); *Bollettino d'Informazioni*, No. 35 (Nov. 1974–Jan. 1975), pp. 2–4; No. 38 (Sept.–Dec. 1975), pp. 1–2; No. 41 (Sept.–Nov. 1976), pp. 4–6; No. 45 (Nov.–Jan. 1978), pp. 1–2. Plan, sections, sketches, details of decoration, etc., L. *D.* i. 40; HAY MSS. 29812, 88–9; BURTON MSS. 25618, 42 [upper], and 25621, 106; NESTOR L'HÔTE MSS. 20396, 348; WILD MSS. iii. 80–96. Names and titles of deceased and father, BRUGSCH, *Thes.* 1448–9 [67].

Blocks. Berlin Mus. 2281 (East), 2282, L. *D. Text*, i, p. 181 [bottom]; see *Ausf. Verz.* p. 263. Chicago, Field Mus. Nat. Hist., and New York, M.M.A. 11.150.50, see SIMPSON in *Kêmi*, xxi (1971), p. 30 note 14. Munich, Staatl. Sammlung, ÄS 5875, 5895–7, MÜLLER (H. W.) in *Münchener Jahrb.* 3 Ser. xxv (1974), Abb. 12 (ÄS 5897), p. 220; ÄS 5896–7, see *Staatl. Sammlung* (1976), p. 154. Another, *Werke ägyptischer Kunst* [etc.] (*Münzen und Medaillen A.G., Auktion 49, Basel, June 27, 1974*), No. 48 with fig.; *The Antiquities of Ancient Egypt (Auction III, Feb. 26, 1978, Joel L. Malter & Co., Inc., Los Angeles, Cal.)*, No. 273 with fig. Two blocks in Cairo Museum.

Three registers of Fields of Iaru, and fifteen columns of text below, WILKINSON MSS. vii. 51–2. Offering-text, and name and titles, id. ib. vii. 44 [lower], 53 [left]. Ḥathor-cow, with child sitting on horns, left of main entrance, see CHAMPOLLION (ed. HARTLEBEN) in *Bibl. Ég.* xxxi, p. 118.

Passage to First Pillared Hall II.

Ceiling with gods in boats, etc., and cartouches of Psammetikhos I.

Second Pillared Hall IV. 1st ed. III.

Sketch, WILKINSON, *Modern Egypt and Thebes* [etc.] (1843), i, fig. on p. 382; id. *M. and C.* iii, fig. on p. 263 = ed. BIRCH, ii, fig. on p. 262; WILKINSON MSS. vii. 46. Text uncovered recently, ZIVIE, op. cit. fig. on p. 66 [upper].

(1) [1st ed. 1–4] (a)–(c) Texts from Book of the Dead. Block from (a), in Dondelinger Colln.

(a) L. *D.* iii. 260 [b]; NESTOR L'HÔTE MSS. 20408 'Tombeau de Bokenranef 5', Q (squeeze). (b) L. *D.* iii. 260 [a, cols. 1, 2]. (c) Id. ib. 260 [a, cols. 3–21]; NESTOR L'HÔTE MSS. 20396, 351, 352 [top].

(2) [1st ed. 5] (a)–(c) Texts from Book of the Dead.

Id. ib. 20407 'Tombeau de Bokenranef 3', three squeezes. (a) and (c) L. *D.* iii. 264 [a, b]. Remaining jamb, NESTOR L'HÔTE MSS. 20407 'Tombeau de Bokenranef 1', B (squeeze).

(3) [1st ed. 6] (a)–(c) Texts from Book of the Dead.

Id. ib. 20407 'Tombeau de Bokenranef 3', three squeezes; L. *D.* iii. 264 [c–e]; BURTON MSS. 25618, 43. Lintel and jambs, NESTOR L'HÔTE MSS. 20407 'Tombeau de Bokenranef 1', C (squeeze).

Ceiling

Deceased before 10th–12th hours of day, and 10th and 11th of night, L. *D.* iii. 259 [d]. 10th (incomplete), 11th and 12th hours of day, BRUGSCH, *Monumens de l'Égypte* (1857), pl. xiii [upper]; 12th of day and night, CHAMP., *Mon.* ccccxli, ccccxlii. Text of 9th hour of day, in Lyons, Mus. des Beaux-Arts, 91–2; DEVÉRIA, *Notice sur les antiquités égyptiennes du Musée*

de Lyon (1857), 1st pl., pp. 22–3 (repr. in *Bibl. Ég.* iv, pl. vi, pp. 93–5 [photos.]); id. squeezes, 6169, i. 41. Beginning of texts of 8th–12th hours of day and 10th and 11th of night, with sketches, WILKINSON MSS. vii. 44 [upper], 45 [right]; names, CHAMPOLLION (ed. HARTLEBEN) in *Bibl. Ég.* xxxi, p. 118. Titles 'on roof between two pillars', BURTON MSS. 25621, 104 [top left]. Details of decoration, PRISSE, *L'Art ég.* i, *Architecture*, 34th pl. [4–6], 35th pl. [top] 'Ornementation des plafonds', *Texte*, p. 370; CHAMP., *Mon.* ccccxxxvii bis [upper middle left and bottom middle]; ROSELLINI, *Mon. Civ.* lxx [4, 9]; L. D. i. 41 [top and middle]; FOŘTOVÁ-ŠÁMALOVÁ, *Egyptian Ornament*, pls. 34 [117], 37 [128], 82; PERROT and CHIPIEZ, *Hist. de l'Art*, i, fig. 537; NESTOR L'HÔTE MSS. 20396, 348 verso–350 verso.

Room V. 1st ed. IV.

Offering-text from jambs at (6) or (10), L. D. *Text*, i, p. 179 [a].

(4) [1st ed. 7, 9] Doorway. (a) Deceased and hymn. (b) Inner doorway.

(a) L. D. iii. 267 [a], *Text*, i, p. 179; hymn, NESTOR L'HÔTE MSS. 20407 'Tombeau de Bokenranef 1', D, E (squeezes). (b) See BURTON MSS. 25618, 42 [lower left].

(5) [1st ed. 8 and 10 incorrectly placed] (a) and (b) Three scenes of deceased before five seated figures of Osiris, offering-list, priests, and offering-bringers.

(a) NESTOR L'HÔTE MSS. 20408 'Tombeau de Bokenranef 4', N, O, P (squeezes). Omitting offering-bringers, L. D. iii. 260 [c]. Offering-list, DÜMICHEN, *Grabpalast*, i, Taf. xviii–xxvi [s]. Remains of Osiris-names, NESTOR L'HÔTE MSS. 20396, 350 verso [middle].

(b) Omitting deceased before figures of Osiris, id. ib. 20408 'Tombeau de Bokenranef 4', M (squeeze). Part, DEVÉRIA squeezes, 5380.F. Osiris-names, BURTON MSS. 25618, 42 [lower], 25621, 107, 107 verso [top]; NESTOR L'HÔTE MSS. 20396, 350 verso [top].

(6) [1st ed. 17] (a)–(c) Texts from Book of the Dead.

L. D. iii. 266 [d–f]. Two sides, NESTOR L'HÔTE MSS. 20407 'Tombeau de Bokenranef 2', two squeezes.

(7) [1st ed. part of 15–16, 20] (a)–(b) Lintel and jambs with offering-texts, (c) deceased before two figures of Osiris, and seated below, (d)–(f) texts from Book of the Dead.

(a)–(c) L. D. iii. 261 [middle and right]. Incomplete (a)–(b), BRUGSCH, *Monumens de l'Égypte* (1857), pl. xviii [B, C, D] (reversed, 12 from elsewhere). (a) BURTON MSS. 25618, 42 [middle left], 25621, 107 verso [bottom]. (c) NESTOR L'HÔTE MSS. 20408 'Tombeau de Bokenranef 4', L (squeeze). (d)–(f) L. D. iii. 265 [a–c]; NESTOR L'HÔTE MSS. 20407 'Tombeau de Bokenranef 3', three squeezes; 20396, 350 verso [bottom].

(8) [1st ed. 11, 12] (a) and (b) Deceased before seated figures of Osiris, and columns of text below.

(a) L. D. iii. 262 [a]. (b) Id. ib. 262 [b] (as south wall).

(9) [1st ed. 14, 15] (a) and (b) Deceased before seated figures of Osiris, and Pyramid-texts below.

(a) Id. ib. 262 [c, right]. Text, NESTOR L'HÔTE MSS. 20407 'Tombeau de Bokenranef 1', G (squeeze). (b) L. D. iii. 261 [left]. Seven columns of text, NESTOR L'HÔTE MSS. 20407 'Tombeau de Bokenranef 1', A (squeeze). Texts in columns 8–11 at (a) and (b), MASPERO, *Inscr.* pp. 46–8 [right column]; id. in *Rec. Trav.* iii (1882), pp. 222–4 [right column].

(10) [1st ed. 18] (a)–(c) Texts from Book of the Dead.

L. D. iii. 266 [a–c]; NESTOR L'HÔTE MSS. 20407 'Tombeau de Bokenranef 2', three squeezes.

(11) [1st ed. 19] (a) Deceased before Osiris seated, and 4 columns of Pyramid-texts below, (b)–(c) lintel and jambs with offering-texts, (d)–(f) texts from Book of the Dead.

(a)–(c) L. D. iii. 262 [c, middle]. Text at (a), MASPERO, *Inscr.* pp. 85–6 [right column]; id. in *Rec. Trav.* iv (1883), pp. 77–8 [right column]. Jambs at (b) and (c), BRUGSCH, *Monuments de l'Égypte* (1857), pl. xviii [B, cols. 5–8]. (d)–(f) L. D. iii. 265 [d–f]; NESTOR L'HÔTE MSS. 20407 'Tombeau de Bokenranef 3', three squeezes.

Ceiling.

Texts and decoration, L. D. iii. 263; ZIVIE in *Archéologia*, No. 79 (Feb. 1975), fig. on p. 66 [lower].

Room VI. 1st ed. V.

(12) [1st ed. 13] Doorway. Right part with offering-texts, L. D. iii. 262 [c, left].

(13) [1st ed. 21–2] (a)–(b) Lintel with offering-text, jambs with remains of titles, and texts from Book of the Dead on either side ((a) much damaged).

Id. ib. 267 [b, c]. One jamb, NESTOR L'HÔTE MSS. 20407 'Tombeau de Bokenranef 1', F (squeeze).

(14) [1st ed. 23–4] (a) and (b) Texts. (c) False-door with offering-texts, in New York, M.M.A. 11.150.50A.

L. D. iii. 268. (c) Left jamb, BRUGSCH, op. cit. pl. xviii [E, cols. 13, 14].

Side-room VII. 1st ed. VI.

(15) [1st ed. 25] Inner doorway. Lintel and jambs with offering-texts.

L. D. iii. 269 [a]; BRUGSCH, op. cit. pl. xviii [A].

(16) [1st ed. 26–8] (a)–(c) Texts from Book of the Dead.

L. D. iii. 269 [b–d]. One block, in Bloch-Diener Colln.; *Das Tier in der Antike* (Archäologisches Institut der Universität Zürich, 21. Sept. bis 17. Nov. 1974), Taf. 12 [53], p. 13.

Ceiling.

One column of text, id. ib. 269 [e].





Main shaft.

Sarcophagus, in Florence Mus. 2182. PETRIE ITAL. photo. 400; one side with kneeling Nephthys, BRESCIANI in *Bull. Soc. fr. d'Ég.* No. 64 (June 1972), fig. on p. 17; texts and scenes, BURTON MSS. 25618, 98, 98 verso–100 verso; 25621, 108–29; 25633, 32–38 verso; HAY MSS. 29848, 10–19; texts, SCHIAPARELLI, *Mus. Arch. Firenze*, pp. 440–53 [1705]; names and titles, LIEBLEIN, *Dict.* No. 1135; see ROSELLINI, *Breve Notizia degli Oggetti di Antichità Egiziane* [etc.] (1830), pp. 11–12 [3]; MIGLIARINI, *Indication*, pp. 44–5.

Offering-table, faience, found by Bresciani.

South shaft. Dyn. XXX. Not yet published.

Demotic graffiti of year 15 of Nektanebos I. See BRESCIANI in *Bull. Soc. fr. d'Ég.* No. 76 (June 1976), p. 6 [middle].

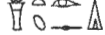

Sarcophagus of Pedeneit  Pashe(n)tihet , Vizier, Prophet of the statues of Amasis, etc., son of Ir'ahor , *warb*-priest of the gods of Memphis, etc., and Tashe(n)-tekert , basalt, fragments. See id. ib. p. 6 [bottom].

Sarcophagus of Ir'ahor , Prophet of Ptaḥ, etc.

Sarcophagus of Ir'ahor , Prophet of Horus of Pe, son of Ubastardais  (mother), basalt.

BN 2 (of Bresciani). PASHE(N)TAISUT , God's father, *sem*-priest, Prophet of Ptah, etc. Dyn. XXX to early Ptolemaic.

Plan LIX.

Parents, 'Ankh-ḥap , *sem*-priest, etc., and Neferu .
Inscribed and decorated doorway, including sun-hymns.

RA^cMOSI , Scribe, Director of all works, . . . of horses, etc. Probably Late Period.

'Tomb with Cow'.

Map LVIII.

Position, BAEDEKER, *Ägypten* (1897), on plan after p. 126.

Remains of texts, some above Western goddess, PETRIE in SAYCE MSS. 22a [middle and bottom], b, c. Large statue of Apis-bull, standing out from wall near shaft, see id. ib. 22a [top].

Column with text of a Greatest of the directors of craftsmen, probably Late Period, lying on slope north-east of tomb. Text, id. ib. 22d.

D. IN THE STEP PYRAMID ENCLOSURE

Old Kingdom.

Double-statue, red granite, and seated statue, black granite, of Nikauhor , Overseer of scribes of the crews, Dyn. V, found in Great South Court, in Cairo Mus. JE 71967-8. LAUER in *Ann. Serv.* xxxix (1939), pls. lxviii, lxix, pp. 449-50; FALLAIZE in *Discovery* (1939), pp. 541, 542. See *Chron. d'Ég.* xv (1940), pp. 67-8.

Middle Kingdom.

Coffin of Sebkhōtp , wood, from shaft east of court of South Building. Text, GUNN MSS. xiii. 2. 1-2. See FIRTH [etc.], *Step Pyr.* i, p. 75 note 1.

New Kingdom. See LAUER, *Pyr. à deg.* i, p. 43 with note 3.



Column-fragment of Nemtimosi , Fan-bearer on the right of the King, etc., Rameside, re-used, in Berlin (East) Mus. 1446. PERRING, *Pyramids*, iii, pl. xii [11]; VYSE, *Operations*, iii, pl. D [5] facing p. 44; BORCHARDT, *Die ägyptische Pflanzensäule*, Abb. 80, p. 51. Text, *Aeg. Inschr.* ii, p. 318; BORCHARDT in *Ä.Z.* xxx (1892), p. 92 note 3; WILKINSON MSS. xx. A. 10 [middle right]. See L. D. *Text*, i, p. 195; *Ausf. Verz.* p. 146.



Column-fragments, including one with offering-text mentioning Wepwaut, Amen-rēc, and Mut, end of Dyn. XVIII to Dyn. XIX. See LAUER in *Ann. Serv.* xxxix (1939), pp. 451-2.

Fragment with Aten cartouches, and statue-fragment, Dyn. XVIII. See id. ib. p. 451.

Female head with earrings, wood with plaster, end of Dyn. XVIII or later, in Cairo Mus. JE 71969. Id. ib. pl. lxx, p. 450; id. *Saqqara*, pl. 112; FALLAIZE in *Discovery* (1939), p. 540; *Chron. d'Ég.* xv (1940), figs. 1, 2, p. 68; *Encycl. phot. Caire*, pl. 89; VANDIER, *Eg. Sculpture*, pl. 59; FORMAN (W. and B.) and VILÍMKOVÁ, *Eg. Art*, pl. 59.

Ptolemaic and Roman.

Coffin and cartonnage of Bek(en)ihet , Overseer of goldworkers of the Temple of Ptah, etc., son of Pa'ca , and anthropoid coffins of Iru , son of Pedehorpashenac

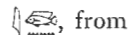
 and *Taçarḥapy* , and of woman In , from Mortuary Temple. Texts, GUNN MSS. xiii. 2. 3-6. See FIRTH [etc.], *Step Pyr.* i, p. 50 note 1, cf. ii, pl. 25 [2].

E. WEST OF THE STEP PYRAMID

Map LVIII

(a) OLD KINGDOM

D 60. *HETEPHERAKHTI* , Judge and Elder of the Hall, Prophet of the Sun-temple of Neuserre, *warb*-priest of Neferirkarē, etc. Temp. Neuserre or later.

Plan LIX.

Chapel. In Leyden Mus. F.1904/3.1.

BOESER, *Beschreibung*, i, Taf. v-xxi; MOHR, *The Mastaba of Hetep-her-akhti in Mededeelingen* [etc.], *Ex Oriente Lux*, No. 5 (1943), with plans on pp. 19, 25; MARIETTE, *Mastabas*, pp. 340-8, with texts and plans. Sketch-plan, VASSALLI MSS. 12 [bottom middle]. Name and some titles, DE ROUGÉ, *Inscr. hiéro.* pl. lxxxi [lower middle]. Details, showing them to be work of several craftsmen, LEEUWENBURG in *Bull. Antieke Beschaving*, xxxix (1964), pp. 50-4 with figs. 1-31. Squeezes in Boston Museum, see DUNHAM in *J.A.O.S.* 56 (1936), p. 173. See BOESER, *Cat.* (1907), pp. 26-9 [1], with plan.

Façade.

(1) [1st ed. 1-3] Doorway. (a)-(b) Lintel with offering-text, and jambs with deceased and son Ni'ankh-ptah , Judge and Scribe, holding hoopoe, and conventional texts of building tomb and rewarding craftsmen, with threat. (c) Drum with name and titles.

BOESER, *Beschreibung*, i, Taf. v-viii; MOHR, pp. 33-6 with figs. Jamb at (a), VAN WIJNGAARDEN, *Meesterwerken*, pl. 20; *Gids* (1953), fig. 7. Texts of lintel and drum, VASSALLI MSS. 12 [bottom, right and left]; of jambs, SETHE, *Urk.* i. 49-51 [31]. Name and titles of son, DE ROUGÉ, *Inscr. hiéro.* pl. xci [lower left, right line].

Entrance corridor.

(2) [1st ed. 4] Registers, I-II, offerings, III-IV, dragging a seated and a standing statue, V, men with an ibex and oryx and young animals in baskets.

BOESER, *Beschreibung*, i, Taf. xix; MOHR, figs. 5-10, pp. 39-43.

(3) Registers, I-II, offerings, III, shrine with statue and mourners in boat towed by rowing-boat and men ashore, IV, dancers and a clapper, and oxen dragging shrine with statue, V, overthrowing cow, and men bringing ox.

BOESER, *Beschreibung*, i, Taf. ix; MOHR, figs. 1-4, pp. 37-9. III-IV, KEES, *Totenglauben und jenseitsvorstellungen der alten Ägypter*, Abb. 2 facing p. 176. III, AMÉLINEAU, *Hist. sépulture*, ii, pl. 1 [4th row right]. Shrine with statue in IV, SCHÄFER, *Von äg. Kunst* (1919), Taf. 18 [1]; (1922 and 1930), Taf. 17 [1]; (1963), Taf. 16 [1]; Eng. ed. *Principles of Egyptian Art*, pl. 27.

(4) Registers, I-III, three boats, including one transporting cattle, IV, men bringing antelope.

BOESER, *Beschreibung*, i, Taf. xx; MOHR, figs. 16-19, pp. 48-50. I-III, WRESZ., *Atlas*, i. 110. III, AMÉLINEAU, op. cit. pl. 1 [3rd row left].

(5) Registers, **I-IV**, baking and brewing, **V**, men securing ox.

BOESER, *Beschreibung*, i, Taf. x, xi; MOHR, figs. 11-15, pp. 43-7; WRESZ., *Atlas*, i. 109. **II-III**, VAN WIJNGAARDEN in *Oudheid. Med.* N.R. xvii (1936), fig. 4, p. 11; AMÉLINEAU, op. cit. pl. xlvi [4th row left]. **II-IV**, PRITCHARD, *Anc. Near East*, fig. 153; NEUBURGER, *The Technical Arts and Sciences of the Ancients*, fig. 167. Baking and brewing, see WILD in *B.I.F.A.O.* lxiv (1966), p. 111 with pl. x (from WRESZ.). **V**, first man on left, KLASENS, *Egyptische kunst*, pl. 15; two men on right, ERMAN and RANKE, *Aegypten und aegyptisches Leben im Altertum* (1923), Taf. 32 [2].

Offering-room.

(6) Inner doorway. (a)-(b) Lintel, netting birds on tree and goats browsing. Jamb, four registers with two offering-bringers in each (bottom register at (a) unfinished).

BOESER, *Beschreibung*, i, Taf. xii, xiii; MOHR, figs. 20-3, pp. 50-2. Lintel, WRESZ., *Atlas*, i. 108; LUGN, *Konst*, fig. 44; netting birds, *Artefact*, pl. 35, p. 33; AMÉLINEAU, op. cit. pl. xviii [5th row right]. Two bottom registers at (a), ASSELBERGHS, *Beeldende Kunst in Oud-Egypte*, fig. 34.

(7) [1st ed. 6] Registers, **I-II**, deceased at table on right, with two sub-registers of offerings in **I**, and musicians, offering-bringers, and men roasting goose in **II**, **III-V**, deceased with son and attendants on left, and ploughing, hacking ground, sowing, and sheep treading grain in **III**, reaping corn and pulling flax in **IV**, piling up sheaves and bringing donkey-herd in **V**, **VI**, donkeys threshing, men piling up sheaves, donkeys transporting produce, **VII** (from right), offering-bringers, butchers, men bringing oryx and ibex.

BOESER, *Beschreibung*, i, Taf. xxi; MOHR, figs. 39-54, cf. pls. iii [41 bis], iv [44 bis, 45 bis, 47 bis, 47 ter, 49 bis], v [51 bis, 52 bis], pp. 76-86; WRESZ., *Atlas*, i. 95-101. **II**, musicians, HICKMANN, *45 Siècles*, pl. lxxviii [B]; *Artefact*, pl. 39, p. 34; KLASENS, *Egyptische kunst*, pl. 16; two groups of men carrying trays near left end, AMÉLINEAU, op. cit. pl. xliv [right, 2nd row]; one group, KLASENS, op. cit. pl. 19. Attendant with sack over shoulder behind deceased in **III-V**, BREMMER, *Eg. kunst*, No. 6. Text before deceased in **III-V**, DE ROUGÉ, *Inscr. hiéro.* pl. lxxxix [bottom]; hieroglyphs of the word *šh*, VAN WIJNGAARDEN, *Meesterwerken*, pl. 26. **IV**, five harvesters at left end, 2nd from left eating onion and 4th drinking, AMÉLINEAU, op. cit. pl. xlvii [5th row right (man on right does not belong)]; 1st to 4th, VAN WIJNGAARDEN, op. cit. pl. 25; 1st and 2nd, BREMMER, op. cit. No. 8; 2nd to 4th, PIRENNE, *Hist. civ.* i, pl. 80 [upper] facing p. 257; 2nd and 4th, BRUNNER-TRAUT, *Die Alten Ägypter*, Taf. 25-6. **V**, men behind donkeys, BREMMER, op. cit. No. 7; man dragging donkey, CAPART, *Memphis*, fig. 363. **VII**, two female offering-bringers, BREMMER, op. cit. No. 10; men with oryx, KLASENS, op. cit. pl. 18.



(8) Registers, **I-II**, on left, deceased seated, with men fowling with clap-net in **I**, and boatmen jousting and men making papyrus-canoe in **II**, **III-VI**, on right, deceased spearing fish from canoe, with man angling, and netting fish in **III**, mat-making, cooking-scene, man cutting open fish and another man drinking in **IV**, tending cattle in **V**, cattle crossing water and herdsmen in boat in **VI**, and below, **VII**, offering-bringers, butchers and men bringing ox.

BOESER, *Beschreibung*, i, Taf. xiv-xvi; MOHR, figs. 24-38, and on pp. v, 31, cf. pls. i [27 bis, 29 ter], ii [34 bis], iii [35 bis, 37 bis], pp. 52-4, 57-65, 74-6; WRESZ., *Atlas*, i. 102-7. Deceased spearing fish, angling scene, man boning fish before an overseer in **III**, and tethered calves in **V**, VAN WIJNGAARDEN, *Meesterwerken*, pls. 21-4, cf. 27. Deceased spearing fish, and ichneumon and birds in papyrus thicket, KLASENS, *Egyptische kunst*, pls. 14, 20; *Artefact*, pls. 36-7, p. 34; fish speared, BREMMER, *Eg. kunst*, No. 9. Man angling, DAUMAS

in *B.I.F.A.O.* lxii (1964), pl. ix, p. 67. III, man boning fish before overseer, id. ib. pl. x, p. 82; PIRENNE, *Hist. civ.* i, pl. 95 facing p. 304; men bringing fish and pulling net, AMÉLINEAU, op. cit. pl. xlvi [4th row left]; three men pulling net, FARINA, *La Pittura egiziana*, Tav. xii; DE BUCK, *Egyptische Verhalen*, frontispiece; WOLF in *Antike und Universalgeschichte* (Festschrift Stier, 1972), Taf. 3 [5]. Man drinking in IV, AMÉLINEAU, op. cit. pl. xlvi [5th row middle]. Overseer, two boys playing, and cow milked in V, MAZAR, *Views*, iv, pl. 86; MOHR in *Jaarbericht Ex Oriente Lux*, No. 7 (1940), pl. ix, fig. 38, pp. 535-41; overseer and boys, ROEDER in *Oudheid. Med.* n.r. xx (1939), Abb. 15, pp. 18-20; cow milked, KLASENS, op. cit. pl. 17; with man with cattle right of it, *Artefact*, pl. 38, p. 34. Tethered calves in V, CAPART, *Documents*, ii, pl. 30 [C].

(9) [1st ed. 7] False-door.

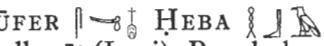
BOESER, *Beschreibung*, i, Taf. xvii, xviii; MOHR, figs. on pp. 87, 90, cf. pl. v [55], pp. 88-101. Two titles from left inner jamb, DE ROUGÉ, *Inscr. hiéro.* pl. xci [lower left].

E 8. SESHEMNÜFER  HEBA , Prophet of the Pyramids of Menkauphor and Zadkarē (Isesi), Royal chamberlain, etc. Temp. Isesi or later.

MARIETTE, *Mastabas*, pp. 398-400.

False-door, top missing (probably not in Cairo Mus. as in 1st ed.). Id. ib. pp. 399-400.

Blocks with estates, with various dealers some time ago. (a) and (b) Two adjoining, *Christie Sale Cat.* March 23, 1971, No. 147 with pl.; *Apollo*, xciii [109] (March 1971), Advertisements, fig. on p. 27 [lower]; Charles Ede Ltd. *Small Sculpture from Ancient Egypt* (London, 1973), No. 1 with fig. (left part). (c) and (d) Two, in Aubert Colln., and (e), at Orient-Occident (dealer in Paris), all probably adjoining and continuation of two preceding, AUBERT in *Orientalia*, n.s. 44 (1975), pls. i-iii, pp. 2-11. (f) MÜLLER-FELDMANN, *Zeugnisse altägyptischer Kultur aus europäischem Privatbesitz* (Folkwang-Museum, Essen, 1. Februar bis 15. März, 1966), No. 80 with Abb. 14. Names of some, MARIETTE, op. cit. p. 398; JACQUET-GORDON, *Domaines*, p. 406 [31S6].

D 59. DUAḤAP , Prophet of Rē in the Sun-temples of Neferirkarē and Neuserrē, Prophet of the Pyramid of Neuserrē, etc. Dyn. VI.

MARIETTE, *Mastabas*, pp. 335-9, with plan of chapel on p. 336.



Façade.

Lintel with offering-text, drum with name and titles, and right jamb with deceased and son. Texts, id. ib. pp. 336-7; of lintel and drum, VASSALLI MSS. 11 [middle]; names and titles, DE ROUGÉ, *Inscr. hiéro.* pl. ci [lower].

Offering-room.

South wall. Deceased, accompanied by wife, spearing fish, and at table, with registers of offering-bringers and butchers below. Texts, MARIETTE, op. cit. pp. 338-9 [C].

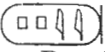
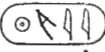
North wall. Deceased fowling with throw-stick, and agricultural scenes. Texts, id. ib. p. 337 [B].

E 9. PEPEZYEDI  (or MERYRĒ'-ZEDI ) ZADI ,
Overseer of scribes, Royal chamberlain, Overseer of commissions. Dyn. VI.

Wife, Methut , Prophetess of Ḥathor, etc.

MARIETTE, *Mastabas*, pp. 401-2, with plan, names and titles, and description.

Scenes in inner room. Deceased fishing, fowling, and being carried in palanquin, and offering-bringers.

SEKHEMKA , Prophet of [Rē'] and Ḥathor in the Sun-temple of Neferirkarē', Prophet of Sed, Neuserrē', and [Neferir]karē', etc. Temp. Neuserrē' or later.

North-west of D 62.

Wife, Khentkaus , Royal acquaintance.

MURRAY, *Saqqara Mastabas*, i, pp. 7-10; plan, pl. xxxv [top right]. Names, titles and translation, id. ib. ii, pp. 23-5 [25].

Façade.

Architrave with offering-text; id. ib. i, pl. vii [top].

Offering-room.

False-door, and on either side of it, deceased seated, with dog under chair, and below, five registers with sons, daughters, officials, offering-bringers and butchers. Id. ib. pl. vii [except top]. Text of lower lintel, SETHE, *Urk.* i. 177 [21 (112), A].

D 62. PTAḤḤOTP [I] , Chief Justice and Vizier, etc. Temp. Isesi.

Plan LX.

MARIETTE, *Mastabas*, pp. 351-6, with plan of part on p. 351; MURRAY, *Saqqara Mastabas*, i (hereafter MURRAY), pp. 11-18 (as Ptaḥḥotp II), with plan of part, pl. xxxiv [upper], and texts and translations by SETHE in ii, pp. 14-17 [20]; HASSAN, *Mastabas of Ny-rankh-Pepy and Others* (hereafter HASSAN), pp. 25-61, with plans and sections, figs. 12, 14-17, and views, pls. xxiv [D], xxvi [B-D], xxvii, xxviii, xxx [B], xxxi [A, B], xlix; id. in *Chron. d'Ég.* xiii (1938), pp. 69 [bottom]-70. Name and titles of son, DE ROUGÉ, *Inscr. hiéro.* pl. lxxxiv [middle]. Plan of area around tomb, BADAWI in *Ann. Serv.* xl (1940), fig. 113 on p. 972; HASSAN, *Mastabas of Princess Hemet-Rc and Others*, fig. 12.

I. Forecourt. Two blocks, HASSAN, pls. xlvii [F], xlviii [A left], p. 60 [5, 6].

(1)-(2) Architrave with name and titles.

Fragments, id. ib. xxiv [A, B, cf. C], pp. 30, 32.

II. Vestibule.

(3) Remains of five registers of offering-bringers.

Id. ib. pls. xxv, xxv bis, xxvi [A], pp. 32-4.

VI. Pillared Hall.

(4)-(7) Pillars with remains of name and titles at (a).

Id. ib. pls. xxix, cf. xxx [A], pp. 36-7. Fragments of another, id. ib. pl. xlviii [D], p. 61 [12].

VIII. Painted Chamber. 1st ed. III, B of Mariette, A of Murray.

(8) [1st ed. 8, 9 incorrectly placed] Doorway. (a) and (b) Remains of deceased.

MURRAY, i, pl. xvii [2, 3], p. 12 [25]; HASSAN, pl. xxxi [C, D], p. 40.

(9)-(12) [1st ed. 3-7] Remains of offerings and offering-bringers.

MURRAY, pls. xv, xvi, pp. 11-12 [24]; HASSAN, pls. xxxii, xxxiii, xxxiv [A, C], pp. 40-1.

IX. Offering-room. 1st ed. IV, A of Mariette, C of Murray.

(13) [1st ed. 1 and 2 incorrectly placed] Doorway. (a) and (b) Painted decoration, three registers of offering-bringers.

MURRAY, pl. xiv [1, 2], p. 17 [35]; texts, HASSAN, p. 41.

(14) [1st ed. 1 and 2 incorrectly placed] Doorway. (a) and (b) Painted decoration, register of offering-bringers.

MURRAY, pl. xiv [3, 4], p. 17 [35]; texts, HASSAN, p. 56.

(15) [1st ed. 10] Remains of registers, **I**, offering-bringers, **II**, donkeys transporting produce, **III**, winnowing, donkeys threshing, and men piling up sheaves, **IV**, men bringing birds, and fowling with clap-net, **V**, butchers.

MURRAY, pl. xi, p. 15 [32]; HASSAN, pls. xxxvii, xxxviii, xxxix [A], pp. 45-8. Texts in **III-V**, MARIETTE, pp. 354, 355 [upper].

(16) [1st ed. 11] Upper part (almost completely lost), deceased at table on right, with offering-bringers. Lower part, son Akhtiḥotp (tomb, see *infra*) as scribe presenting list to deceased on right, and estates.

MURRAY, pls. ix, x, xiii [left], pp. 13-15 [28]; HASSAN, pls. xliv-xlvi, pp. 48-51. Some texts in lower part, MARIETTE, p. 353 [middle and bottom]. Names of estates, JACQUET-GORDON, *Domaines*, pp. 380-3 [24S5], Nos. 1-17, cf. figs. 152-3; of Nos. 1-5 (of JACQUET-GORDON), DE ROUGÉ, *Inscr. hiéro.* pl. lxxxix [bottom].

(17) [1st ed. 13] Upper part, remains of two registers of offering-bringers before [deceased at table]. Lower part, estates.

MURRAY, pls. xii, xiii [right], xvii [7], pp. 15-16 [33]; HASSAN, pls. xxxix [B]-xliv, pp. 51-5, and pl. xvii [D], pp. 59-60 [4]. Estates Nos. 23-5 (of JACQUET-GORDON), MARIETTE, *Voyage*, i, pl. 7, pp. 31-8; LAGIER, *L'Égypte monumentale et pittoresque*, pl. 12; ALDRED in PIGGOTT, *The Dawn of Civilization*, pl. on p. 121 [55]. Texts, MARIETTE, pp. 352, 353 [top]. Names of estates, JACQUET-GORDON, op. cit. pp. 380, 383-5 [24S5], Nos. 18-34, cf. figs. 152, 154; of Nos. 22-6, DE ROUGÉ, op. cit. pl. lxxxiv [top].

(18) [1st ed. 12] False-door.

MURRAY, pl. viii, pp. 12-13 [27]; MARIETTE, pp. 355 [lower], 356; HASSAN, pls. xxxiv [B], xxxv, xxxvi, fig. 13, pp. 42-5. Deceased from middle left jamb, in Madison (Wisconsin), University of Wisconsin, Elvehjem Art Center, 1973.141; *Apollo*, xcvi [141] (Nov. 1973), Advertisements, fig. on p. 224; *The Burlington Magazine*, cxv [848] (Nov. 1973), Advertisements, fig. on p. cxvi; *The Art Journal*, xxxiii [4] (Summer 1974), fig. on p. 353 [bottom left], cf. p. 352; see *Sotheby Parke-Bernet Sale Cat.* Dec. 7, 1973, No. 155.

Altar. Name and titles, MURRAY, pl. xvii [1]; HASSAN, pls. xxxiv [D], cf. xxxiv [B], xxxv, p. 45.

Finds

Blocks (some intrusive). MURRAY, pl. xvii [4-6, 8-13], p. 17 [37], cf. SETHE in *ib.* ii, p. 17; HASSAN, pls. xvii [A, E], xviii [A right, C, E, F], pp. 59 [3], 60 [7, 8], 61 [11, 13], 60 [9].

Two wooden statues, presumably from here, found by Abdulsalam M. Husein in 1940, in Cairo Mus. JE 72379-80.

False-door of Sefekhu , Judge and Book-keeper, fragment, Dyn. V-VI. Id. ib. pl. xlvii [C], p. 59 [2].

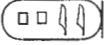
Offering-table of Nikaupepy , Sole companion, fragment, Dyn. V-VI. Id. ib. pl. xlvii [B], p. 58 [1].

Cylinder seal, with Horus-name of Raʿneferef, probably from here, in Cairo Mus. JE 72209. FISCHER in *Metropolitan Museum Journal*, 6 (1972), fig. 23, p. 14 with note 32.

Stopper of Zadkarē Isesi, and two sealings with names of Khephren and Raʿneferef respectively, allegedly from here, in Cairo Mus. JE 72204-6.



THEFU , Lector-priest, etc. End of Dyn. V or Dyn. VI.

Map LVIII.

HASSAN, *Mastabas of Princess Hemet-Rē and Others*, pp. 11-13, with plan and section of shaft, fig. 8, and view, pl. vi. See id. in *Chron. d'Ég.* xiii (1938), p. 68 [middle].

Two wooden statues, incomplete. Id. *Mastabas* [etc.], pls. vii, viii, p. 12.

Rectangular wooden coffin of deceased, fragments. Id. ib. pl. ix, pp. 12-13.

D 63. ITETI  'ANKHIRIS , Elder of the *is*-chamber in the Two Houses, Overseer of the Palace (*rh*), etc. Dyn. VI.

MARIETTE, *Mastabas*, pp. 357-9, with plan.

Offering-room.

False-door, with statue at back of niche and offering-list on inner jambs, in Cairo Mus. CG 57190. MURRAY, *Saqqara Mastabas*, i, pls. xviii, xix, pp. 18-19, with titles, SETHE in ib. ii, pp. 17-18 [21]; MASPERO, *Guide*, fig. 5, p. 88 [239]; id. *Égypte*, fig. 61; id. and ROEDER, *Führer*, Taf. 13 [left], p. 29 [172]; TARCHI, *L'Architettura*, Taf. 12 [left]; LEIBOVITCH, *Anc. Eg.* fig. 65, p. 94 [239]; HAMANN, *Äg. Kunst*, Abb. 144; WOLDERING, *Götter*, Abb. 19; SHOUKRY, *Privatgrabstatue*, Abb. 67, p. 235; LANGE and HIRMER, *Aegypten*, pl. 73; WESTENDORF, *Das Alte Ägypten*, fig. on p. 65; RIESTERER, *Kunstschatze . . . Kairo*, pl. 8; ALDRED, *Tutankhamun's Egypt*, fig. 77; PANOFKY, *Tomb Sculpture*, fig. 10; incomplete, MURRAY, *Sculpture*, pl. xi [1]; WOLDERING, *Ägypten. Die Kunst der Pharaonen*, pl. on p. 57 (reversed); POULSEN, *Äg. Kunst. A. und M.* pl. on p. 23; panel, NESTOR L'HÔTE MSS. 20405, 69 (squeeze); offering-list, HASSAN, *Giza*, vi [2], pls. xxv-xxxii [30], p. 121; names and titles, MARIETTE, op. cit. p. 358.

Statues of deceased. In Cairo Museum. From south room. See id. ib. pp. 358-9.

Seated, CG 45. BORCHARDT, *Statuen*, i, Bl. 12, pp. 41-2; WEIGALL, *Anc. Eg. . . . Art*, 68 [upper left]; DE ROUGÉ, *Album photo.* pls. 103-5; HORNE-MANN, *Types*, iii, pl. 705; text, FISCHER in *J.A.R.C.E.* ii (1963), p. 25 [top]; see MASPERO, *Guide*, p. 67 [146].

Standing, with feet together, CG 47. BORCHARDT, op. cit. Bl. 12, p. 43; MASPERO, *Égypte*, fig. 25; HORNE-MANN, op. cit. i, pl. 12.

D 64. MASTABA-COMPLEX.

Plan LX.

Plan and sections, DAVIES, *The Mastaba of Ptahhetep and Akhetetep* [etc.], i, on pls. i, ii; ii, on pls. i, ii. Plan, MARIETTE, *Mastabas*, fig. on p. 359.

(a) AKHTIḤOTP , Chief Justice and Vizier, Overseer of the Pyramid-towns and Inspector of prophets of the Pyramids of Neuserrê, Menkauhor and Zadkarê, etc. Temp. Isesi to Unis.

Father, Ptaḥhotp [I] (tomb D 62).

DAVIES, *The Mastaba of Ptahhetep and Akhetetep* [etc.], ii. Collation of texts, ČERNÝ Notebook, 119, pp. 38-57.

II. Corridor.

(1)-(2) Remains of three boats, hunting scenes and men filling wine-jars (all painted only and much effaced), and below, register of estates and men with tethered calves on left.

DAVIES, ii, pls. iv [lower], x, xi, with additional blocks found later, id. *Five Theban Tombs*, pl. xl, p. 44. Names of estates, JACQUET-GORDON, *Domaines*, pp. 386-90 [25S5], Nos. 1-17, cf. figs. 155-6.

(3) Deceased with eldest son Ptaḥhotp [II] as child, and registers, **I-II**, almost completely lost, **III**, netting fowl, **IV-V**, men bringing birds and papyrus plants (partly unfinished).

DAVIES, ii, pls. iv [upper right], v, vi. Titles of deceased, and first three men in **IV**, MILNE Photo. Album, 2. 12 [lower]. Some titles, DE ROUGÉ, *Inscr. hiéro.* pl. lxxxix [top]. First four men in **IV-V**, DAUMAS, *Civ. de l'Ég.* pl. 197.

(4) Deceased with son Ptaḥhotp [II], with attendants behind them (above doorway), and registers of harvest scenes, **I**, reaping corn, **II**, donkeys carrying produce, **III** (almost completely lost), sifting and winnowing, with men with stubborn donkey on right, **IV**, donkeys and cattle threshing, **V**, piling up sheaves and bringing donkeys.

DAVIES, ii, pls. iii [lower], iv [upper left], vii-ix. **I-V**, LAUER, *Saqqara*, pl. 55. Cattle threshing in **IV**, SPIEGELBERG, *Geschichte*, Abb. 21; incomplete, KUSCH, *Ägypten im Bild*, Abb. 62 [upper] (as Ty).

IV. Hall.

(5) and (6) [1st ed. 5 and 11] Deceased seated, with registers before him. (5) **I**, men bringing papyrus plants and birds, **II-III**, boatmen jousting, **IV**, herdsmen with cattle crossing canal, and man fishing with dip-net. (6) **I**, herdsmen with cattle, **II**, men making papyrus-canoes, **III-IV**, bringing and pulling papyrus, and man angling. At bottom of both walls, **V**, estates before son Ptaḥhotp [II]. Above doorway, papyrus thicket with birds hovering.

(5) DAVIES, ii, pls. xiv, xvi. Some titles, DE ROUGÉ, *Inscr. hiéro.* pl. xci [top]. Man with dip-net in **IV**, WRESZ., *Atlas*, iii. 97 [B]. One estate (= No. 31) in **V**, JACQUET-GORDON, op. cit. pl. ii facing p. 275. Names of estates, id. ib. pp. 386, 391, 394-5 [25S5], Nos. 31-5, cf. figs. 155, 157 [c].

(6) DAVIES, ii, pls. xiii, xv. **III-IV**, WRESZ., *Atlas*, iii. 42. Names of estates, JACQUET-GORDON, op. cit. pp. 386, 391-4 [25S5], Nos. 18-30, cf. figs. 155, 157 [b].

(7) [1st ed. 6] Registers, **I**, two groups of men dragging chests with feathers on top, **II**, herdsmen with cattle, **III-IV**, offering-bringers, **V-VI**, butchers.

DAVIES, ii, pls. xxii, xxiii.

(8) and (9) [1st ed. 7 and 8] Deceased with son Ptaḥhotp [II], followed by officials and son Ptaḥhotp [II], and before them, six registers of men bringing cattle at (8), and bringing wild animals at (9).

(8) DAVIES, ii, pls. xx, xxi. (9) Id. ib. pls. xviii, xix.

(10)-(11) [1st ed. 9-10] Registers, **I-II**, herdsmen tending cattle, **III**, offering-bringers, **IV-VI** (sketches with guide-lines only), offerings and offering-bringers.



DAVIES, ii, pl. xvii. Men eating palm-cabbage in I, BRUIJNING in *Anc. Eg.* (1922), fig. 18 (from DAVIES), p. 7.

V. Offering-room.

(12) and (13) [1st ed. 12 and 14] Deceased at table, with [offering-list], offerings, and four registers of offering-bringers.

(12) DAVIES, ii, pls. xxx-xxxiv, cf. xii [upper]; additional fragment of offering-list (now replaced), HASSAN, *Mastabas of Ny-ankh-Pepy and Others*, pl. lxii [E], p. 84 [4]. (13) DAVIES, ii, pls. xxiv-xxvii; additional fragments of offering-list and titles (now replaced), HASSAN, op. cit. pls. lxi, lxiii [A, B], pp. 83-4 [3].

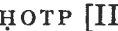
(14) [1st ed. 13] False-door (top missing). DAVIES, ii, pls. xxviii, xxix.

(b) ПТАННОТР [II]  THEFI , Chief Justice and Vizier¹, Inspector of prophets of the Pyramids of Menkauhor and Isesi, Inspector of *warb*-priests of the Pyramid of Neuserrê, etc. Temp. Isesi to Unis.

Father, Akhtihotp (see preceding tomb).

DAVIES, *The Mastaba of Ptahhetep and Akhetetep* [etc.], i; PAGET and PIRIE in QUIBELL, *The Ramesseum*, pls. xxxi-xli, with description by GRIFFITH, pp. 25-34 (plates with corrections and additions by N. DE GARIS DAVIES in DAVIES MSS. 2. 111-12); HASSAN, *Mastabas of Ny-ankh-Pepy and Others*, pp. 63-84, with plans and sections, figs. 18, 19. Name and some titles, DE ROUGÉ, *Inscr. hiéro.* pl. lxxxvii [bottom right]. Squeezes in Boston Museum, see DUNHAM in *J.A.O.S.* 56 (1936), p. 173.

Offering-room.

View, CAPART, *L'Art ég.* (1911), pl. 106; id. *L'Art ég.* i, pl. 47; id. *Memphis*, fig. 228; MORET, *Le Nil*, pl. iv [3]; FRANKFORT, *Ancient Egyptian Religion*, pl. 21 (as Ty); LAGIER, *L'Égypte monumentale et pittoresque*, pl. 11; *Egypt Exploration Fund. Archaeological Report 1898-1899*, frontispiece.

(15) [1st ed. 15, 16] Doorway. (a) Registers, I, man bringing cattle, II-IV, men with animals, fowl, and offerings. (b) Registers, I, two sub-registers of fowl, II-IV, men with animals, fowl, and offerings.

(a) PAGET and PIRIE, pl. xxxvii [left]; DÜMICHEN, *Resultate*, Taf. x [right]. I, DAVIES, i, pl. iii [lower left].

(b) PAGET and PIRIE, pl. xxxvii [right]. Man carrying gazelle, in IV, DAVIES, i, pl. xvi [bottom right].

(16) [1st ed. 23-4] Upper part (partly above doorway), deceased seated, with attendants (including one with dogs and monkey) behind him, and before him, men with linen, and registers, I, harpist, singer, and dwarfs making jewellery, II-III, officials (including Thetui, Elder of the dockyard) squatting, IV, offerings, man eating fruit, and musicians. Lower part (left of doorway), registers, V-VI, offering-bringers, VII-VIII, butchers.



DAVIES, i, pl. xxx [lower]; PAGET and PIRIE, pls. xxxv [lower], xxxvi.

Upper part, WRESZ., *Atlas*, iii. 2. Man with dogs and monkey, MARBURG INST. photo. 86912; dogs and monkey, DÜMICHEN, *Resultate*, Taf. x [left upper]. I, man with linen, and harpist and singer, HICKMANN, *45 Siècles*, pls. xx, cvii [A]; harpist and singer, id. *Ägypten*, Abb. 54; singer, id. in *Bull. Inst. Ég.* xxxiv (1951-2), fig. 11, p. 243 = id. *Musicologie*

¹ On the sarcophagus only.

pharaonique, fig. 11, p. 111; jewellers, AMÉLINEAU, *Hist. sépulture*, ii, pl. xlvi [3rd row, right]. Left parts of III–IV, DÜMICHEN, op. cit. Taf. x [left lower]. Man eating fruit, and musicians, in IV, EBERS, *Aegypten*, i, fig. on p. 192 [top]; Eng. ed. fig. on p. 167 [top].

Lower part, DÜMICHEN, op. cit. Taf. xi. VII (omitting man on left), GHALIOUNGUI, *Magic and Medical Science* (1973), pl. 9. Irenakhti , Physician, in VII, id. in *Egypt Trav. Mag.* No. 108 (1963), fig. 5, pp. 25–6; DARBY, GHALIOUNGUI and GRIVETTI, *Food: The Gift of Osiris*, i, fig. 3.28. Butchers and Irenakhti, see LEIBOVITCH in *J.N.E.S.* xii (1953), pp. 59–60, cf. fig. 1 (from PAGET and PIRIE).

(17) Deceased with son Ptaḥhotp [III] as child, and Kaseshem , Judge and Boundary official, behind them, and registers, I, papyrus-harvest, and herdsmen with cattle crossing water, II, boys playing games, III, vintage scenes, IV, two sub-registers of hunt in desert, including lassoing antelopes, V, two sub-registers, building papyrus canoes, including making ropes, and man cutting out roes of fish, VI, two groups of men netting fowl, VII, four canoes, 1st to 3rd, boatmen jousting, 4th, Ni'ankh-ptah , Overseer of sculptors, feasting.

DAVIES, i, frontispiece, pls. iii [upper], xviii [top], xxi [left], xxii [lower], xxiii, xxv, xxvi; PAGET and PIRIE, pls. xxxii, xxxiii [lower]; DÜMICHEN, *Resultate*, Taf. viii; WRESZ., *Atlas*, iii. 14 [left], 15, 16. Almost complete, LAUER, *Saqqara*, pls. 57–9. Deceased, PIJOÁN, *Summa Artis*, iii (1945), fig. 237.

I, AMÉLINEAU, *Hist. sépulture*, ii, pl. xlv [top row]. Left part of I–III, with some animals in IV, CHAMPDOR, *L'Égypte des Pharaons*, pl. on p. 31. Right part of I–III, with titles, GRIFFITH INST. photo. 317.

II, AMÉLINEAU, op. cit. pl. xlix [2nd row]. Omitting group on left, TOUNY and WENIG, *Sport*, Taf. 32–40. Throwing sticks at target, FAVRE, *L'Arte*, fig. on p. 113. Boys sitting cross-legged, one carrying two others on back, one sitting on ground, boys swinging others, and playing game, SMITH, *Hist. Eg. Sculp.* figs. 201, 211, 185 [upper left], 221 [lower], 215, pp. 323, 331, 338, 316, 319, 332. Left part, EBERS, *Aegypten*, i, fig. on p. 191 [top]; Eng. ed. fig. on p. 166 [top]. High jump, DUNHAM, *The Egyptian Department and its excavations*, fig. 119 (from squeeze); EATON in *Boston Mus. Bull.* xxxv (1937), fig. on p. 55 [upper] (from squeeze), cf. pp. 54–5; with two boys with arms round each other's neck, SAAD in *Ann. Serv.* xxxvii (1937), pl. i [B], pp. 214–15.

III, AMÉLINEAU, op. cit. pl. xlvi [top row]. Wine-press, MONTET in *Rec. Trav.* xxxv (1913), fig. 9, p. 123. Left part of III, EBERS, *Aegypten*, i, fig. on p. 68; Eng. ed. fig. on p. 60. Right part of IV–VII, WOLF, *Kunst*, Abb. 202–3.

IV–V, CAPART, *Memphis*, figs. 383, 234; almost complete, CHAMPDOR, *L'Égypte des Pharaons*, pl. on pp. 28–9. Right part of IV–V, SMITH, *Hist. Eg. Sculp.* pl. 55 [b], p. 192; left part, CAPART, *L'Art ég.* iii, pl. 443; PIJOÁN, *Summa Artis*, iii (1945), fig. 193; LANGE, *Ägypten. Landschaft*, pl. 44; KEES, *Ägypten* (OTTO, *Handbuch der Altertumswissenschaft*, iii, Pt. 1, vol. iii, *Kulturgeschichte des Alten Orients*, 1), Taf. 15. IV, WRESZINSKI, *Löwenjagd im alten Aegypten in Morgenland*, 23 (1932), Taf. 3 [8], p. 5; omitting some animals, AMÉLINEAU, op. cit. pl. xlviii [2nd row]. Right part of IV, RANKE, *Meisterwerke*, Abb. 23a; FAVRE, *L'Arte*, fig. on p. 153; DARBY, GHALIOUNGUI and GRIVETTI, *Food: The Gift of Osiris*, ii, fig. 3.2; MÜLLER, *Äg. Kunst*, Abb. 36–7; omitting man with lasso, id. *Alt-Ägyptische Malerei*, Taf. 5. Middle of part IV, VANDERSLEYEN, *Das Alte Ägypten*, Abb. 254. Man lassoing antelopes, MASPERO, *Hist. anc.* i, fig. on p. 63 [lower]; antelopes, WOLF in *Antike und Universalgeschichte* (Festschrift Stier, 1972), Taf. 2 [3], p. 5. Two wild dogs, KEIMER in *B.I.F.A.O.* lv (1955), p. 10 [A] with figs. 3 (from WRESZ.), 3 bis (sketched by H. Wild). Left part of IV, EBERS, *Aegypten*, i, fig. on p. 191 [middle]; Eng. ed. fig. on p. 166 [middle].

Left end of **IV** with man with dogs, HILZHEIMER in *Antiquity*, vi (1932), pl. ix [11], p. 417; HOUTART in *Chron. d'Ég.* ix (1934), fig. 2, p. 28.

Right end of **V-VI**, COTTRELL, *Egypt*, fig. 33 (as Idut). **V**, AMÉLINEAU, op. cit. pl. xlii [2nd row]. Men in boat-building scenes, some showing physical deformities, GHALIOUNGUI in *Ä.Z.* 87 (1962), Taf. i, ii [a], pp. 108-9; id. *Magic and Medical Science* (1963), pls. vi, vii; WOLF, op. cit. Taf. i [2], p. 4; POSENER, SAUNERON and YOYOTTE, *Dict. civ.* fig. on p. 288. Boat on right, KÖSTER, *Das antike Seewesen*, Taf. 1 facing p. 16. Man cutting out roes, KEIMER in *Bull. Inst. Ég.* xxi (1938-9), pl. i [1], pp. 219-20 [1].

Right part of **VI-VII**, MARIETTE, *Voyage*, pl. 11, pp. 41-2; HAMANN, *Äg. Kunst*, Abb. 153; TOUNY and WENIG, *Sport*, Taf. 48; OTTO, *Ägypten. Der Weg des Pharaonenreiches*, Abb. 9 (as Ty); right end, DRIOTON and SVED, *Art ég.* fig. 31. Left part of **VI-VII**, CAPART, *Paysage*, fig. 33; id. *Memphis*, fig. 240; omitting end, PIJOÁN, *Summa Artis*, iii (1945), fig. 196. **VI**, AMÉLINEAU, op. cit. pl. xlvi [bottom]; right end, BARTA, *Das Selbstzeugnis eines altägyptischen Künstlers*, Taf. xxiii [37]; omitting texts and man on left end, SAMEH, *Daily Life*, figs. on pp. 21 [upper], 22-3; left part, SPIEGEL, *Hochkultur*, Taf. 56 [b]. Men pulling nets, MICHALOWSKI, *Art*, fig. 251. Netting fowl, DARBY, GHALIOUNGUI and GRIVETTI, *Food: The Gift of Osiris*, i, fig. 6.1 (rubbing); see SPIEGEL in *Mitt. Kairo*, 15 (1957), p. 233, cf. Taf. xlv [2] (from WRESZ.).

VII, AMÉLINEAU, op. cit. pl. xlix [5th row]; GROENEWEGEN-FRANKFORT and ASHMOLE, *Art of the Ancient World*, fig. 38 (as Sekhem(ankhptah)); MICHALOWSKI, *Art*, fig. 249. Man with umbilical hernia in 2nd canoe from right, GHALIOUNGUI, *Magic and Medical Science* (1963), fig. 4, p. 87; (1973), fig. 6, p. 86; id. in *Ä.Z.* 87 (1962), Taf. ii [b], p. 109 [3]. 1st and 2nd canoes, MASPERO, *Égypte*, fig. 118; GILBERT, *Méditerranée antique* [etc.], fig. 15; SCHÄFER, *Äg. Kunst*, fig. on p. 15 [3]; 2nd and 3rd, ALDRED, *Egypt*, fig. 136; incomplete, MICHALOWSKI, *Piramidy i mastaby*, pl. 21; 2nd to 4th canoes, EBERS, *Aegypten*, i, fig. on p. 188 [top]; Eng. ed. fig. on p. 164 [top]; 4th with Ni(ankh-ptah), MASPERO, op. cit. fig. 111; ERMAN in *Ä.Z.* xxxi (1893), Taf. ii, pp. 97-8; SPRINGER, *Die Kunst des Altertums* (1923), Abb. 67; MEYER, *Aegypten zur Zeit der Pyramidenerbauer*, Abb. 10, p. 28; DAUMAS, *Civ. de l'Ég.* pl. 198.

(18) Deceased with son Akhtihotp as child, and registers, **I**, boys, one of them with arms tied, running, and six pairs wrestling, **II**, men dragging cages with leopard and lion, bringing young and small animals in boxes slung on poles, and hyenas and dogs on leash, **III**, bringing wild animals, **IV-VI**, herdsman tending and bringing cattle, **VII**, bringing fowl.

DAVIES, i, pls. xxi [right], xxii [upper], xxiv, xxvii, xxviii; PAGET and PIRIE, pls. xxxiii [upper], xxxi; DÜMICHEN, *Resultate*, Taf. ix; WRESZ., *Atlas*, iii. 14 [right], 17, 18. Deceased, ŽÁBA in *Dějiny Afriky*, i, fig. on p. 230. Upper part of deceased and some text above, CAPART, *Memphis*, fig. 183; FETT, *Mumier og sfinks*, pl. on p. 19. Upper part of deceased, PIJOÁN, *Summa Artis*, iii (1945), fig. 192.

Titles, and **I-III**, GRIFFITH INST. photo. 318. **I-III**, MONTET, *Eternal Egypt*, pl. 81; left parts, PIJOÁN, op. cit. fig. 194; CHAMPDOR, *L'Égypte des Pharaons*, pls. on pp. 26-7; LANGE, *Ägypten. Landschaft*, pls. 42-3; left end, id. *Lebensbilder*, Abb. 10; CAPART, *L'Art ég.* iii, pl. 442; ANGIOLETTI and BIGONGIARI, *Testimone*, Tav. 19. **I**, AMÉLINEAU, *Hist. sépulture*, ii, pl. xlix [top row]; TOUNY and WENIG, *Sport*, Taf. 1-3, 42. Text above boys running, ERMAN, *Reden, Rufe und Lieder*, p. 60 [3] (as from Ramesseum). Wrestlers, WILSDORF, *Ringkampf im alten Ägypten*, Taf. i [9] (from cast), pp. 15-18, and 53 [top]; 1st and 2nd pairs, BYVANCK, *De Kunst*, pl. ix [34]; 2nd to 6th, EBERS, *Aegypten*, i, fig. on p. 188 [bottom]; Eng. ed. fig. on p. 164 [bottom]; 4th to 6th, RANKE, *The Art of Ancient Egypt*, and BREASTED, *Geschichte Aegyptens* (1936), 210; DIEM, *Körperkultur im alten Aegypten* in *Olympische*

Rundschau (1938), fig. 39, p. 20; DE WIT, *Oud-Egyptische Kunst*, fig. 36 facing p. 72; DONADONI, *La Civiltà Egiziana*, fig. 14 facing p. 128; id. *Arte Egizia*, fig. 51; GALASSI in *Critica d'Arte*, n.s. ii (1955), fig. 259, p. 313.

Left end of **II-III**, RANKE, *The Art of Ancient Egypt*, and BREASTED, *Geschichte Aegyptens* (1936), 193. **II**, AMÉLINEAU, op. cit. pl. xlix [3rd row]. Right half, EBERS, *Aegypten*, i, fig. on p. 191 [bottom]; Eng. ed. fig. on p. 166 [bottom]. Men dragging cages, WRZESINSKI, *Löwenjagd im alten Aegypten in Morgenland*, 23 (1932), Taf. 3 [9], p. 6; VANDERSLEYEN, *Das Alte Ägypten*, Abb. 255. Man with dogs and hyenas, MASPERO, *Hist. anc.* i, fig. on p. 63 [upper] (reversed).

III, AMÉLINEAU, op. cit. pl. xl [top row].

IV, birth of calf, DARBY, GHALIOUNGUI and GRIVETTI, *Food: The Gift of Osiris*, i, fig. 3.11 (rubbing).

V-VII, LANGE and HIRMER, *Ägypten. Architektur* (1967), pl. 71; omitting left end, LAUER, *Saqqara*, pl. 56.

VI-VII, BAIKIE, *Eg. Antiq.* pl. v [upper]; CAPART, *Memphis*, fig. 386; id. *L'Art ég.* iii, pl. 441; MARBURG INST. photos. 86913-14; right half, LANGE, *Ägyptische Tierplastik*, Abb. 6; omitting right end, JÉQUIER, *Hist. civ.* fig. 128; MONTET, *Eternal Egypt*, pl. 79. Overseer and men with 1st bull in **VI**, MASPERO, *Égypte*, fig. 115; LANGE, *Lebensbilder*, Abb. 4; DRIOTON and SVED, *Art ég.* fig. 30; DE RACHEWILTZ, *L'Arte*, Tav. 46; omitting man behind bull, ŽÁBA in *Dějiny Afriky*, i, fig. on p. 231; with one man of 2nd group and some fowl in **VII**, CAPART, *Rue de Tombeaux*, pl. cv; id. *L'Art ég.* (1909), pl. 23; men with bull, CHASSINAT in *B.I.F.A.O.* x (1912), fig. 2 (from cast), p. 172; SPRINGER, *Die Kunst des Altertums* (1923), Abb. 65; HAMANN, *Äg. Kunst*, Abb. 157; BRUNNER-TRAUT, *Die Alten Ägypter*, Taf. 8b; DARBY, GHALIOUNGUI and GRIVETTI, *Food: The Gift of Osiris*, i, fig. 3.15; man at front, PIJOÁN, *Summa Artis*, iii (1945), fig. 202 (as Ty); LANGE, *Äg. Kunst*, pl. 37. Men with 2nd bull, BAIKIE, *A Century of Excavation in the Land of the Pharaohs*, pl. 28; id. *The Story of the Pharaohs*, pl. v [1]; PETRIE, *Egypt in Encyclopaedia Britannica* (1910), pl. iii [37] facing p. 66; id. in WRIGHT, *Twentieth Century Impressions of Egypt*, fig. 2 on p. 124 [upper]; man at front and bull, PETRIE, *Arts and Crafts*, fig. 57 facing p. 51; with one man of 1st group, MICHAŁOWSKI, *Piramidy i mastaby*, pl. 20; man at front, BAUMANN, *Die Welt der Pharaonen* (1959), pl. on p. 36.

VII, AMÉLINEAU, op. cit. pl. xl [2nd row]. Overseer and cranes, LANGE, *Äg. Kunst*, pl. 32; BYVANCK, *De Kunst*, pl. xxiii [84]; SCHÜZ, *Über Stelzvögel* [etc.] in *Die Vogelwarte*, 23 (1966), Abb. 7 on p. 269. Cranes, PIJOÁN, *Summa Artis*, iii (1945), fig. 209 (as Mereruka); SAMEH, *Daily Life*, fig. on p. 20. Some fowl, id. ib. figs. on pp. 18 [upper], 19 [lower]; EBERS, *Aegypten*, i, figs. on pp. 185, 192 [middle]; ii, fig. on p. 55 [middle]; Eng. ed. i, figs. on pp. 161, 167 [middle]; ii, fig. on p. 48 [middle]; LANGE, *Ägypten. Landschaft*, pl. 40; DE CENIVAL, *Living Architecture: Egyptian*, pl. 43; DARBY, GHALIOUNGUI and GRIVETTI, *Food: The Gift of Osiris*, i, fig. 6.26.

(19) Deceased at table, and registers, **I-II**, offerings, **III-IV**, estates, **V**, offerings and butchers, **VI-VII**, offering-bringers and offerings.

PAGET and PIRIE, pls. xxxv [upper], xxxiv; DÜMICHEN, *Photo. Result.* xiii. Reconstruction of text above deceased, DAVIES, i, pl. iii [lower right]. Deceased, and **IV-VII**, MASPERO, *Hist. anc.* i, fig. on p. 255 (as Ty). Upper part of deceased, text above, and names of estates, DÜMICHEN, *Resultate*, Taf. xv. Names of estates, JACQUET-GORDON, *Domaines*, pp. 398-402 [28S5-6], cf. figs. 161-2. Offerings in **VII**, MICHAŁOWSKI, *Piramidy i mastaby*, pl. 18 (as Ty).

(20) False-door, with deceased carried in palanquin and seated in kiosk on jambs. (21)

Offering-list, with deceased at table smelling ointment-jar, and I, priests, II-IV, offering-bringers and offerings. (22) Uninscribed false-door.

DAVIES, i, pls. xix-xxA, xxix, xxx [upper]; PAGET and PIRIE, pls. xxxviii-xli; DÜMICHEN, *Resultate*, Taf. xii-xiv; PERROT and CHIPIEZ, *Hist. de l'Art*, i, fig. 115.

(20) List of festivals on upper lintel, BRUGSCH, *Thes.* 236 [top]. Lower part, GRIFFITH INST. photo. 319 [left]. Some texts, SETHE, *Urk.* i. 188-9 [28-9 (119-20)].

(21) WRESZ., *Atlas*, iii. 3; with missing fragment of offering-list replaced, HASSAN, *Giza*, vi [2], frontispiece, pls. lvii-lxiv [69], p. 132. Offering-list, DÜMICHEN, *Grabpalast*, i, Taf. xviii-xxvi [e]; GRIFFITH INST. photo. 319 [right]. Deceased, LANGE, *Äg. Kunst*, pl. 30; id. *Lebensbilder*, Abb. 3; id. and HIRMER, *Aegypten. Architektur* (1955 and 1957), pl. 72; (1967), pls. 70, 72 [upper]; ANTHES, *Meisterwerke*, Taf. xxxiv; id. *Aeg. Plastik*, Taf. 42; *Great Museums*, fig. on p. 193 [21]; ALDRED, *Egypt*, fig. 104; BAUMANN, *Die Welt der Pharaonen* (1959), pl. on p. 53; MÜLLER, *Äg. Kunst*, Abb. 34; id. in *Encyclopedia of World Art*, iv, pl. 334 [right]; WOLDERING, *Götter*, fig. on p. 229 [Kat. 45]; SHURINOVA, *Iskusstvo Drevnego Egipta*, pl. 47; DIRINGER and REGENSBURGER, *The Alphabet* (1968), ii, pl. 2.7b on p. 43; *Apollo*, cii (1975), fig. 6, p. 93; upper part, POSENER, SAUNERON and YOYOTTE, *Dict. civ.* fig. on p. 163. Deceased and II-IV (omitting right end), LAUER, *Saqqara*, pl. vii. II-IV, MÜLLER, *Äg. Kunst*, Abb. 35. II, 1st to 3rd offering-bringers, WOLF in *Antike und Universalgeschichte* (Festschrift Stier, 1972), Taf. I [1], p. 3; 1st and 2nd, BOULANGER, *Ägyptische und Altorientalische Malerei*, fig. on p. 185. 1st and 3rd offering-bringers in II, and 2nd to 4th in III, AMÉLINEAU, *Hist. sépulture*, ii, pl. xlv [3rd and 4th rows right]. III, 2nd to 4th offering-bringers, MICHALOWSKI, *Art*, fig. 252; 2nd to 5th, SOGA, *The Nile*, fig. on p. 52 [upper]; 3rd to 5th, WOLF, *Hochkulturen*, Abb. 82; 4th and 5th, BAROCAS, *Egypt*, fig. 16 (as Ty). IV, offerings and one offering-bringer, DARBY, GHALIOUNGUI and GRIVETTI, *Food: The Gift of Osiris*, i, fig. 6.19b, and ii, fig. 12.11.

(22) PERROT and CHIPIEZ, *Hist. de l'Art*, i, pls. xiii, xiv after pp. 804, 810; PIJOÁN, *Summa Artis*, iii (1945), fig. 191.

Burial chamber.

Inscribed sarcophagus. HASSAN, *Mastabas of Ny-cankh-Pepy and Others*, pls. lii, liii, p. 67; see id. in *Chron. d'Ég.* xiii (1938), p. 68 [upper].

Finds (mostly intrusive). Dyn. V-VI

False-doors.

Khnem'ankhu  Pepy . . .  . . .  Overseer of tenants of the Great House, etc., fragments. HASSAN, *Mastabas of Ny-cankh-Pepy and Others*, pl. lxvii, fig. 20, pp. 72-3 [1].

Sefekhu  Book-keeper of the *mert*(?). Id. ib. pl. lxviii [B], p. 74 [3].

A Judge and Inspector of scribes, fragment. Id. ib. pl. lxix [A], fig. 21, p. 74 [2].

Blocks.

Mereru  re-used block. HASSAN, *Mastabas of Ny-cankh-Pepy and Others*, pl. lxxi [C], pp. 78-9 [12].

Neferhōtep  Director of the dining hall of the Great House, etc., lintel-fragments. Id. ib. pl. lxix [E], fig. 22, p. 75 [1].

Senbu  Id. ib. pl. lxx [A], fig. 25, p. 76 [5].

An Overseer of the Two Treasuries, etc., with remains of unconventional text. Id. ib. pl. lxviii [C], pp. 77-8 [9].

Remains of autobiographical text. Id. ib. pl. lxx [B left], fig. 29, p. 80 [15].

Remains of three registers, including oxen dragging [sledge with statue or coffin] and *mw*w-dancers. Id. ib. fig. 28, p. 79 [13]; JUNKER in *Mitt. Kairo*, 9 (1940), Abb. 3, pp. 4-5 [b].

Others. HASSAN, *Mastabas* [etc.], pls. lxvi [C right], lxviii [A, D, E], lxix [B, D], lxx [B right, C], lxxi [A], figs. 26, 23, 24, 27, pp. 76 [6], 75-6 [3], 78 [10, 11], 76 [4], 77 [7], 80 [16], 79 [14], 75 [2].

Offering-tables and basins.

Ptaḥḥotp-wēr , with names of *ka*-servants. HASSAN, *Mastabas of Ny-cankh-Pepy and Others*, pl. lxiv [B], pp. 70-1 [1]; id. *Giza*, v, fig. 31, p. 183.

Ptaḥḥotp, *ka*-servant, and others. Id. *Mastabas* [etc.], pl. lxv [B], p. 71 [4].

Ptaḥḥotp. Id. ib. pl. lxvi [A], p. 71 [3].

Ipti , fragment. Id. ib. pl. lxvi [C left], p. 72 [6].

A Scribe of the royal documents in the presence, fragment. Id. ib. pl. lxv [A], p. 71 [2].

A Royal chamberlain, etc. Id. ib. pl. lxvi [B], p. 72 [7].

A Sole companion. Id. ib. pl. lxxi [B], pp. 71-2 [5].

Coffins.

Two inscribed wooden anthropoid coffins and cartonnage, Late Period or Ptolemaic. HASSAN, *Mastabas of Ny-cankh-Pepy and Others*, pls. lv-lx, pp. 80-2.

THEFU  (probably also ПТАḤḤОТP), Royal Chamberlain. End of Dyn. V.

Map LVIII.

Father (probably), Akhtiḥotp (tomb D 64,a).

Plan, HASSAN, *Mastabas of Princess Hemet-Rc and Others*, fig. 7; see id. *Mastabas of Ny-cankh-Pepy and Others*, pp. 105-13, with views, pl. lxxxiii.

Pillared Hall.

East wall. [Deceased], and registers of dancers and men dragging large jars. Id. ib. pl. lxxxiv [A], fig. 55, pp. 107-8.

South wall. Registers of offering-bringers and men carrying large chest, and men in canoes (including fishing with small net). Id. ib. pl. lxxxiv [B], figs. 56-7, pp. 108-9.

Offering-room.

Bottom part of south false-door. Id. ib. pl. lxxxv [A], fig. 58, pp. 110-11.

Blocks. Dyn. V-VI. Probably intrusive



Three registers of offering-bringers. Id. ib. pl. lxxxvi [A], p. 112 [1].

Lion seizing antelope, from hunting-scene. Id. ib. pl. lxxxvi [C], fig. 59, pp. 112-13 [2].

Man cooking(?). Id. ib. pl. lxxxvi [B], p. 113 [3].

Other finds

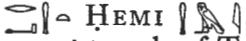
Offering-table of Ptaḥ[ḥotp] Thefu, alabaster, perhaps from here, in Cairo Mus. CG 1332. BORCHARDT, *Denkmäler*, i, Bl. 5, pp. 15-16. See MASPERO, *Guide*, p. 43 [81].



D 65. HEMTRĒꜥ  HEMI , King's daughter of his body (of Unis), Prophetess of the *mert*-temple of Teti, etc. Early Dyn. VI.



Map LVIII.

HASSAN, *Mastabas of Princess Hemet-Rc and Others*, pp. 1-10, with plans and sections, figs. 1, 3, 5, 6, and view, pl. i.

False-door. Id. ib. pls. ii, iii, fig. 2, pp. 4-7; MARIETTE, *Mastabas*, fig. on p. 360, cf. p. 359; some texts, SETHE, *Urk.* i. 80 [4].

Sarcophagus. HASSAN, op. cit. pl. iv, pp. 7-8; texts, id. *Giza*, v, pp. 16, cf. 17; see id. in *Chron. d'Ég.* xiii (1938), p. 68 [lower].

Lintel with offering-text of These mu , 'Brother of the endowment' of Ptaḥḥotp (probably II), etc., and wife Rakher , with children, found in shaft. Id. *Mastabas* [etc.], pl. v, fig. 4, pp. 8-10.

AKHTIḤOTP  IPI-UZAU , Judge and Overseer of scribes, etc. Dyn. VI.

Map LVIII.

HASSAN, *Mastabas of Princess Hemet-Rc and Others*, pp. 15-20, with sections of shafts, figs. 9, 10.

Wooden statuette of deceased. Id. ib. pls. x, xi [A], p. 16 [1].

Fragments of seated statue of deceased. Id. ib. pls. xi [B-D], xii [A], fig. 11, pp. 16-17 [2]; id. in *Festschrift Golenishchev (Drevniy Egipt. Sbornik statey.)*, figs. on pp. 239-40, cf. pp. 237-8, 241.

Architrave-fragment of Merut , Prophetess of Neith, etc., Dyn. VI. Id. *Mastabas* [etc.], pl. xii [B], pp. 17-18 [3].

PTAḤḤOTP IYNI , Overseer of scribes of the Great Court, etc. End of Dyn. V or Dyn. VI.

Map LVIII.

HASSAN, *Mastabas of Ny-ankh-Pepy and Others*, pp. 115-16, with view, pl. lxxxvii [A].

Lintel of doorway. Id. ib. pl. lxxxvii [B], pp. 115-16.

PTAḤḤOTP IYNI ANKH , Judge and Overseer of scribes, Prophet of SaḥurĒꜥ, etc. End of Dyn. V or early Dyn. VI.

Map LVIII. Plan LX.

HASSAN, *Mastabas of Ny-ankh-Pepy and Others*, pp. 85-104, with plans and sections, figs. 30, 42, 51-4, and views, pl. lxxii; id. in *Chron. d'Ég.* xiii (1938), p. 69 [top].

Chapel. Mostly painted decoration only.

Two wooden statuettes and fragments of others. Id. *Mastabas* [etc.], pl. lxxx [B-D], pp. 99-100 [1-5, 7].

Passage.

(1) Remains of three registers, men driving rams, offering-bringers, and boatmen jousting.

Id. ib. fig. 31, p. 87.

Offering-room.

(2) Doorway. (a) and (b) Deceased, and remains of two registers, offering-bringers at (a), and men bringing animals at (b).

Id. ib. figs. 32-3, pp. 87-9.

(3) (a)-(b) Above doorway, two scenes of men making bed under canopy. (a) Four registers of cooking. (b) Three registers, men cutting open fish, milking scene, bringing milk and calf.

Id. ib. pls. lxxix, lxxx [A], figs. 39-41, pp. 97-8. Text of man cooking meat at (a), ČERNÝ Notebook, 118, p. 101 verso [right upper].

(4) (much damaged) Deceased seated, with three registers of men dragging sledge(?), men in boats, netting fish, musicians and dancers, and men bringing wine below.

HASSAN, *Mastabas* [etc.], pl. lxxvii, figs. 35-7, pp. 93-5.

(5) (much damaged) Offering-list, with three registers of offering-bringers, priests, and butchers.

Id. ib. pl. lxxviii, fig. 38, pp. 95-7. Offering-list, id. *Giza*, vi [2], pls. lvii-lxiv [68], p. 132.

(6) False-door, and in front of it, basalt offering-table embedded in limestone slab, and limestone bench, all inscribed.

Id. *Mastabas* [etc.], pls. lxxiii-lxxvi, figs. 34a, b, pp. 89-92, 99. Offering-table and slab, id. *Giza*, v, fig. 30, p. 182.

Burial chamber.

Inscribed sarcophagus. Id. *Mastabas* [etc.], figs. 43-50, pp. 101-2.

Ointment-slab, inscribed in ink. Id. ib. pl. lxxxi [F], pp. 102-3 [1].

MERERI , Chief Justice and Vizier, etc. Late Dyn. VI.

Map LVIII.

HASSAN, *Mastabas of Princess Hemet-Rc and Others*, pp. 25-39, with plans and section, figs. 16, 19, and views, pls. xv, xvi [B], xxiv [A]; id. in *Chron. d'Ég.* xiii (1938), p. 69 [middle].

Two obelisks with name and titles. Id. *Mastabas* [etc.], pl. xvi [C, D, cf. A], p. 28.

False-door. Id. ib. pl. xvii, figs. 17b, cf. 17a, pp. 29-33.

Lower part of deceased at table, with offering-bringers below, on north wall of offering-room. Id. ib. pl. xviii [A], fig. 18, pp. 34-5.

Remains of wooden statuette, from serdab. Id. ib. xxiii [E], p. 35.

Offering-table of Khuy , Inspector of tenants of the Great House, Dyn. V-VI. Id. ib. pl. xxiv [D], p. 39 [2].

Burial chamber.

East wall. Three registers with offerings, granaries, and bound ox; id. ib. pl. xx, p. 37.

South wall. Six chests; id. ib. pl. xviii [C], p. 37.

North wall. Remains of offering-list; id. ib. pl. xix, p. 37.

Sarcophagus, with representations of vessels with ointments. Id. ib. pls. xxi, xxii, fig. 20, pp. 36-7.

Blocks re-used or found in the mastaba. Dyn. V-VI.



Birds in papyrus thicket, with name of Teti, probably from his Mortuary Temple; id. ib. pl. xxiii [A], p. 35. Boat being rowed, with text mentioning an Inspector of prophets of the

Pyramid of Teti; id. ib. pl. xviii [B], pp. 33-4. Thefu , Scribe of a phyle; id. ib. pl. xxiii [G], fig. 21, p. 37. Calves, and milking cow; id. ib. pl. xxiv [C], fig. 23, p. 39 [3]. Cutting out roes of fish; id. ib. pl. xxv [A], fig. 24, p. 39 [4]. Eel, id. ib. pl. xxv [B], p. 39 [5]. Others; id. ib. pls. xxiii [B, C], xxiv [B], fig. 22, pp. 37-8, 38-9 [1].



SHEPSIPUPTAḤ , Elder of the Hall of the Pyramid of Zadkarē (Isesi), *ka*-servant of Ptaḥhotp [I]. End of Dyn. V or Dyn. VI.

North of tomb of Mereri.

Lintel of false-door. BADAWI in *Ann. Serv.* xl (1940), pl. lx, pp. 573-7.

False-doors. Thetui , Elder of the dockyard, etc., probably son, fragmentary upper part; id. ib. pl. lxvi, pp. 607-10. Theset , Prophetess of Ḥathor, etc., wife of Thetui; id. ib. Abb. 67, pp. 611-12.

FROM THE AREA OF D 63-5 AND ADJOINING TOMBS

False-doors, Dyn. VI. Ipti , Lector-priest; BADAWI in *Ann. Serv.* xlii (1943), pl. viii [b], pp. 127-9. Ptaḥhotp, Noble of the King, and Ipti, Inspector of prophets of Horus in the chapel (*snwt*); (a) id. ib. pl. viii [a], pp. 129-30; (b) upper part, with Ikri , offering; pl. ix, pp. 130-1.

D 61. DUAENRĒ , Overseer of scribes of the land in the Two Houses, Prophet of Rē in the Sun-temple of Neferirkarē, etc. Middle Dyn. V or later.

Wife, Thentet , Prophetess of Ḥathor Mistress of the Sycamore, etc.

MARIETTE, *Mastabas*, pp. 348-50, with plan of chapel on p. 349.

Hall.

Titles and name of wife from marsh scene, id. ib. p. 350 [upper]; DE ROUGÉ, *Inscr. hiéro.* pl. lxxxv [top].



Name of estate, id. ib. pl. lxxxv [middle right]; JACQUET-GORDON, *Domaines*, p. 356 [16S5], cf. fig. 137.

South pillar. Offering-text, MARIETTE, *op. cit.* p. 349 [lower].

Offering-room.

Offering-bringers and men bringing animals. Names and titles, id. ib. p. 350 [lower].

False-door. Lower part, id. ib. pp. 455-6 [H 15]; names and titles of deceased and sons, DE ROUGÉ, *op. cit.* pls. lxxxv [middle], ci [upper]. Panel, in Cairo Mus. CG 1511; text, BORCHARDT, *Denkmäler*, i, p. 216.

‘ANKHI  INTHI , Prophet of the Pyramids of Unis and Teti, Metal-worker of the Great House, etc. End of Dyn. VI.

Map LVIII.

GOYON (G.) in *Kémi*, xv (1959), pp. 10-22 with plates; plan, fig. on p. 11. Some titles, ČERNÝ Notebook, 118, p. 101 verso [left].



Niche. (a)–(b) Lintel-fragment with figures of deceased and names and titles. Jambes with remains of address. (c) and (d) Deceased with titles. (e) and (f) Identical religious texts, and deceased below. (g) and (h) Deceased at table, with offering-list and register of offering-bringers. (i) False-door.

(a)–(b) GOYON (G.), op. cit. pls. i [1–3], vii [1], pp. 11–15; (c) and (d) pls. v [7, 8], vii [8], viii [7], pp. 19–20; (e) and (f) pls. iii [5, 6], iv [5, 6], vii [6], ix [5, 6], pp. 17–18; (g) and (h) pls. iv [9–11], vi [9, 10], x [9, 10], pp. 21–2; (i) pls. ii [4], viii [4], pp. 16–17.

ZA‘A‘TI , Overseer of metal-workers of the Great House, etc. Probably Dyn. VI.



Near tomb of ‘Ankhi.

Two titles, ČERNÝ Notebook, 118, p. 101 verso [middle upper].

AKHTIḤOTP  IPI , Inspector of prophets of the *ka*-temple of Pepy I, Prophet of the Pyramid of Merenrē I, etc. Temp. Merenrē I or later.

North of tomb of Neferkhuu-ptah.

False-door. LAUER in *Ann. Serv.* liii (1956), pl. vii, p. 158; see id. in *Bull. Soc. fr. d'Ég.* 12 (Feb. 1953), p. 31.

NEFERKHUU-PTAḤ  THETHI , Count, Chief of an estate of the Pyramid of Pepy I, etc. Temp. Pepy I or later.

Map LVIII.



DRIOTON and LAUER in *Ann. Serv.* lv (1958), pp. 234–7, 251, with plan on pl. i, cf. fig. 23, and view, pl. xxi [a]; LAUER in *Bull. Soc. fr. d'Ég.* 12 (Feb. 1953), pp. 30 [lower]–31; LECLANT in *Orientalia*, n.s. 19 (1950), p. 491 [bottom].

Wooden statuettes, found in shaft. Three, women kneeling, squatting, and standing leaning forward, see DRIOTON and LAUER, op. cit. pp. 246–7 [1–3]. Man squatting, see id. ib. p. 247 [7].

Offering-room.

False-door. Id. ib. pls. xxii [a], xxiii, pp. 235–6.

East wall. Remains of painted scenes with offerings and butchers, id. ib. pl. xxi [b], p. 237.

ISHETHI  THETHI , Chief of estates of the Pyramids of Pepy I and II, Overseer of the nomes of Lower Egypt, etc. Temp. Pepy II or later.

Map LVIII.

DRIOTON and LAUER in *Ann. Serv.* lv (1958), pp. 207–27, 251, with plans and sections, on pls. i, ii, and view, pl. iii; *Chron. d'Ég.* xxiv (1949), pp. 240–1.

Niche.

Side walls. Deceased at table, with offering-list, priests, and offerings, and below, offering-bringers and butchers; DRIOTON and LAUER, op. cit. pls. iv, v [a–c], pp. 208–12.

False-door, fragmentary. Id. ib. pl. vi [a], pp. 212–14; see LECLANT in *Orientalia*, n.s. 19 (1950), pp. 491 [near bottom], 492 [top].

Serdab with wooden statues and models. Mostly in Cairo Museum.

View *in situ*, LAUER in *Rev. d'Ég.* vii (1950), pl. i [a], pp. 15-16; id. *Saqqara*, pl. 124; DRIOTON and LAUER, op. cit. pl. vii [a], pp. 214-15.

Two, deceased with staff and sceptre, inscribed, JE 88575-6. LAUER, in *Rev. d'Ég.* vii (1950), pl. i [c, b], p. 16 [1, 2]; DRIOTON and LAUER, op. cit. pls. viii, ix, pp. 215-16 [a, b]; JE 88575, PERKINS in *A. J. A.* liii (1949), pl. viii, p. 41; upper part, LAUER, *Saqqara*, pl. 122.

Man in long kilt, found in shaft, JE 88577. Id. in *Rev. d'Ég.* vii (1950), pl. ii [a, b], p. 18 [top]; id. *Saqqara*, pl. 123; DRIOTON and LAUER, op. cit. pl. xiv, p. 218.

Man, found in shaft, JE 88578. LAUER in *Rev. d'Ég.* vii (1950), pl. ii [d], p. 18 [near top]; DRIOTON and LAUER, op. cit. pl. xv, pp. 218-19.

Female offering-bringer, JE 88579. LAUER, op. cit. pl. ii [c, right], p. 16 [3]; DRIOTON and LAUER, op. cit. pls. x [a, b, both right], xi [a, b, both right], p. 216 [c].





Woman pounding grain, JE 88580. LAUER, op. cit. pl. ii [c, left], pp. 16-17 [4]; DRIOTON and LAUER, op. cit. pls. x [a, b, both left], xi [a, left], p. 216 [d].



Rower, man and kneeling female mourner, last two JE 88581-2. Id. ib. pls. xi [b, left], xii, pp. 216-17 [d, e]; see LAUER, op. cit. p. 17 [5]; mourner, see FISCHER, *Varia*, p. 44, cf. fig. 10.

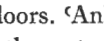

Burial chamber. Painted decoration.

Offering-list, offerings, granaries, and palace-façade. DRIOTON and LAUER, op. cit. pls. xvii-xix, pp. 219, 222-7; see LAUER, op. cit. p. 18 [lower].

Found nearby. Dyn. VI.

False-doors. 'Ankhi ; see DRIOTON and LAUER, op. cit. p. 229 [d]. Isi , Prophetess of Hathor, etc.; id. ib. pl. v [d], pp. 228 [a], 229 [a]. Sedekhi , Prophetess of Hathor, King's sole adorer, etc., with lintel; id. ib. pl. xx [a, b], pp. 229-31 [b]. Sethet , King's sole adorer, etc. (woman); id. ib. pl. xx [c], pp. 229 [c], 231-3 [c].

Lintels. Ikri  and wife Khuitenba ; id. ib. pl. vi [b], p. 234. Imbi , Overseer of the granary, Keeper of the magazine, etc.; id. ib. pl. xx [d], pp. 233-4.

SEBKEMKHENT  SEBEKY , Real count, Chief of an estate of the Pyramid of Pepy I, Inspector of prophets of the Pyramid of Pepy II, etc. Temp. Pepy II or later.

Map LVIII.

DRIOTON and LAUER in *Ann. Serv.* lv (1958), pp. 237-48, with plan on pl. i. See LAUER in *Bull. Soc. fr. d'Ég.* 12 (Feb. 1953), p. 30 [upper].

Chapel.

Lintel with offering-text and address, jambs with titles. DRIOTON and LAUER, op. cit. pl. xxiv, pp. 239-41.

False-door. LECLANT in *Orientalia*, n.s. 19 (1950), pl. lvii [6], p. 492; LAUER in *Ann. Serv.* liii (1956), pl. iii, p. 155; texts, DRIOTON and LAUER, op. cit. pp. 237-9.

Offering-table. Id. ib. fig. 17, pp. 241-2.



Found in shaft.

Offering-table, with model grains of corn, in Cairo Mus. JE 89602. Id. ib. fig. 18, pp. 244-5 [1]; LAUER in *Ann. Serv.* liii (1956), pl. vi [2], p. 156.

Statues of deceased, fragmentary, in Cairo Mus. (a) Squatting, JE 89599, DRIOTON and LAUER, *op. cit.* pl. xxv [a, left], pp. 242-3; LAUER in *Ann. Serv.* liii (1956), pl. iv, p. 155; id. in *Bull. Soc. fr. d'Ég.* 22 (Nov. 1956), fig. 2 [left], pp. 56-8. (b) and (c) Seated, JE 89600-1, DRIOTON and LAUER, *op. cit.* pl. xxv [a middle and right, b], p. 243; LAUER in *Ann. Serv.* liii (1956), pls. v, vi [1], pp. 155-6; id. in *Bull. Soc. fr. d'Ég.* 22 (Nov. 1956), fig. 2 [middle and right], pp. 56-8.

Intrusive burial south of mastaba.

Anthropoid coffin, inscribed, Dyn. XXX. LAUER in *Ann. Serv.* liii (1956), fig. 5, p. 159.

ANKHI  ITHI , Overseer of the *wabt*, etc. Dyn. V.

Map LVIII.

DRIOTON and LAUER in *Ann. Serv.* lv (1958), pp. 249-50, 251, with plan on pl. i.

False-door, incomplete. Id. *ib.* pl. xxii [b], pp. 249-50; LAUER in *ib.* liii (1956), pl. viii, p. 159.

E 14. NEZEMIB  Overseer of metal-workers of the Great House, *mḥnk* of the King. Dyn. VI.

Wife, Nefert .



Lintel with offering-text and address, in Cairo Mus. CG 1732. BORCHARDT, *Denkmäler*, ii, Bl. 94, p. 162; MARIETTE, *Mastabas*, p. 417; address, BRUGSCH, *Thes.* 1212 [middle]; SETHE, *Urk.* i. 75 [1].

E 15. ITY  DUARÉ  *, Prophet of the *mert*-temple of Menkauhor, etc. Temp. Menkauhor or later.

MARIETTE, *Mastabas*, pp. 418-19, with plan of chapel. Name and titles, LIEBLEIN, *Dict.* No. 1383.

False-door. Texts, MARIETTE, *op. cit.* p. 419.

H 1. NISU-USERT  Overseer of the ten craftsmen, Inspector of craftsmen of the *wabt*. Dyn. V-VI.

Mother, Nefertentes . Wives, Mesti  and Inneferhatḥor .

In Cairo Museum.

Incomplete false-door, CG 1444. Texts, BORCHARDT, *Denkmäler*, i, pp. 126-7; some, MARIETTE, *Mastabas*, p. 443.

Two blocks from side of niche, with name and title, CG 1688, 1733. Texts, BORCHARDT, *op. cit.* ii, pp. 136, 162.

PERNEZU  [Overseer] of scribes of the crews, Scribe of enrolment of the crew of the boat, [Overseer] of the expedition, etc. Dyn. VI.

Position unknown.

Wife, Ni'ankh-ḥatḥor , Royal acquaintance.

False-door. Upper part, formerly in Lee and Amherst Collections; WILKINSON MSS. xv. 56; text, WIEDEMANN in *P.S.B.A.* xi (1889), p. 420 [6]; CRUM in GARDINER Notebook, 66, p. 17 [upper]; see [BONOMI], *Cat. . . Hartwell House*, p. 80 [561]; *Sotheby Sale Cat.* March 16, 1833, No. 561; ib. (AMHERST), June 13-17, 1921, No. 187. Blocks, in Cairo Mus. CG 1684, 1689-90, 1718; BORCHARDT, *Denkmäler*, ii, Bl. 92 (CG 1718), pp. 134, 136-7, 154 (texts).

False-door of wife, in Cairo Mus. CG 1506. Id. ib. i, Bl. 44, p. 211.

(b) LATE AND PTOLEMAIC PERIODS



LATE PERIOD SHAFT.

Map LVIII.



Text of Chapter 72 of Book of the Dead, from wooden anthropoid coffin. CHÂBAN in *Ann. Serv.* xix (1920), p. 209.





PTOLEMAIC TOMB A.

Map LVIII.



Rectangular sarcophagus of 'Ankh-ḥap , Prophet, Overseer of troops, son of Tabanep  (mother), granite, in Cairo Mus. CG 29301. MASPERO, *Sarcophages*, i, pls. i-v, pp. 1-73; astronomical scenes on inside of lid, NEUGEBAUER and PARKER, *Egyptian Astronomical Texts*, iii, pp. 52-3 [38] with fig. 13; see MASPERO, *Guide*, pp. 268-9 [1300].



Anthropoid sarcophagi. In Cairo Museum.



'Ankhet , daughter of Unnūfer, Commander of the army, Mayor of Busiris, etc., and Sethet , JE 4739. BUHL, *Sarcophagi*, fig. 74, pp. 124-6 [H, 1], cf. pl. ix (titles); DEVÉRIA squeezes, 6196, 13-15; Wind-gods, BRUGSCH, *Thes.* 850 [v] (as Louvre); text, PIEHL, *Inscr. hiéro.* 1 Sér. lxx-lxxi [J]; names, LIEBLEIN, *Dict.* No. 1313; title of father, see DE MEULENAERE in *Bibliotheca Orientalis*, xvii (1960), p. 33 [H, 1].

Gemḥap , son of Pedenēsi  and Taneitiu(?)  Renpetnefert , basalt, Temp. Nos. 23.1.21.7-8. SCHMIDT, *Levende og Døde*, figs. 1231-2 on p. 219; text, PIEHL, *Inscr. hiéro.* 1 Sér. xii-xl [B]; names, LIEBLEIN, *Dict.* No. 1315; see BUHL, op. cit. pp. 92-3 [F, a 3]; MASPERO, *Guide*, p. 271 [1307].

Ḥekenut , daughter of Renpetnefert (mother), JE 17431. See BUHL, op. cit. pp. 111, 114 [F, b 2] (names); names, LIEBLEIN, *Dict.* No. 1314; see MASPERO, *Guide*, pp. 270-1 [1305].

Herubaste , daughter of Ēsiarḥesbet  (mother), basalt, Temp. Nos. 22.1.21.5-6. BUHL, op. cit. fig. 12, p. 48 [E, a 10]; name, see DE MEULENAERE in *Bibliotheca Orientalis*, xvii (1960), p. 33 [Ea, 10]; see MASPERO, *Guide*, p. 270 [1304].



Nefarud , Commander of the army, son of Uza  (mother), lid, JE 4740. BUHL, op. cit. fig. 55, p. 93 [F, a 4], cf. pl. v (title).

Sethet , daughter of Semset  (mother), lid, JE 6400. Id. ib. fig. 54, p. 93 [F, a 5].

Unnūfer, Prophet, son of Herubaste  (mother), basalt, Temp. No. 3.3.21.1. Id. ib. fig. 9, pp. 39-40 [E, a 2], cf. pl. ii (title); names, LIEBLEIN, *Dict.* No. 1074; see MASPERO, *Guide*, p. 271 [1308].



PTOLEMAIC TOMB B.



Map LVIII.

Rectangular sarcophagus of Zehō , Overseer of the granary, Overseer of the Treasury, etc., son of 'Ankhefensekhmet  and Irterau , granite, in Cairo Mus. CG 29302. MASPERO, *Sarcophages*, i, pls. vi-viii, pp. 73-86; headless Osiris and divinities, DELATTE in *Bulletin de Correspondance Hellénique*, xxxviii (1914), fig. 8, pp. 233-4 with note 3 (as CG 34647); MASPERO, *Guide*, fig. 96, p. 268 [1298].

FINDS FROM WEST OF THE STEP PYRAMID

Male statue, fragmentary, Middle Kingdom, in Cairo Mus. CG 999. Text, BORCHARDT, *Statuen*, iv, p. 20.

Fragment of statue of Ze-ēsef'ankh  son of Psammethk and Ēsiardais , holding figure of Osiris, schist, Dyn. XXVI, in Cairo Mus. CG 1058. Text, id. ib. p. 42.

Two pillars of User  , *warb*-priest of the two hundred, Overseer of officials (*srw*), etc., Dyn. VI, in Cairo Mus. CG 1550-1. Id. *Denkmäler*, ii, Bl. 56-7, pp. 8-9.

Block with registers, I, rope-making, II, making papyrus-canoe, III, text only, Dyn. V, in Cairo Mus. CG 1697. Id. ib. ii, Bl. 90, p. 141; texts, ČERNÝ Notebook, 118, p. 95.

Block with registers of men (including one with baboon) and wild animals, Dyn. VI. HASSAN, *Mastabas of Princess Hemet-Rc and Others*, pl. xiv [C], pp. 23-4.

F. AROUND THE PYRAMID-COMPLEX OF UNIS

Maps LXI, LXII

(a) EARLY DYNASTY II

LAUER, *Pyr. à deg.* i, p. 5; iii, p. 53; id. *Hist. mon.* i, pp. 56-9. Position, id. in *Comptes Rendus* (1954), fig. 3 on p. 377; id. in *Bull. Inst. Ég.* xxxvi (1953-4), fig. 4, pp. 363-4; id. *Hist. mon.* i, fig. 55; id. *Observations sur les pyramides*, fig. 16; id. *Les Pyramides de Sakkarah* (1972), fig. 71, p. 18; FISCHER in *Artibus Asiae*, xxiv (1961), fig. 8 (from LAUER), pp. 46-8.

TOMB A.

Beneath east side of the Pyramid. Superstructure lost.

BARSANTI in *Ann. Serv.* ii (1901), pp. 250-2; iii (1902), pp. 183-4. Plan and section, LAUER, *Pyr. à deg.* i, fig. 2, p. 5; id. in *Mitt. Kairo*, 15 (1957), Taf. xx [4], pp. 160-1; id. *Hist. mon.* i, plan 6 [a]; FISCHER, op. cit. fig. 9 (from LAUER), pp. 46-8.

Sealings. Hetepsekhemui, in Cairo Mus. JE 35586-8, 35590-5; Ra'neb, JE 35584-5, 35609-18; Perneb , King's son, JE 35598-608; illegible, JE 35619. MASPERO in *Ann. Serv.* iii (1902), pp. 187-90; id. in *Bull. Inst. Ég.* iv Sér. No. 3, pp. 107-10 (repr. in *Bibl. Ég.* xxix, pp. 256-8); NEWBERRY MSS. ii.E.I.41.

TOMB B.

About 140 metres east of last. Superstructure lost.

Sealings of Ninüter. See HASSAN in *Ann. Serv.* xxxviii (1938), p. 521; *Chron. d'Ég.* xiii (1938), p. 283 [iv]; *Archiv aeg. Arch.* 1 (1938), pp. 182-3.

(b) OLD AND MIDDLE KINGDOMS

Plan, HASSAN, *The Mastaba of Neb-Kaw-Ḥer*, plan at end; showing tombs south of the Causeway (by Abd el Salam), ZAYED in *Ann. Serv.* lv (1958), pl. i, p. 128; DE RACHEWILTZ, *The Rock Tomb of Irw-k3-Pth*, pl. i; description, LAUER, *Les Pyramides de Sakkarah* (1972), pp. 20-2.

KHENTKAUS  |, King's eldest daughter of his body. Probably Dyn. VI.

West of next tomb.

SAAD, *Royal Excavations at Saqqara and Helwan (1941-1945)* in *Ann. Serv. Cahier*, 3 (1947), pp. 62-6, cf. pls. xxvi, xxix-xxxii [a]; id. in *Chron. d'Ég.* xx (1945), pp. 81-2; SCHWEITZER in *Orientalia*, N.S. 17 (1948), p. 266 [top].

Offering-room.

False-door. SAAD, op. cit. pl. xxv, pp. 62-4.



Remains of painted offering-list and offering-bringers. Id. ib. pl. xxiv, p. 62.

Burial chamber.



Sarcophagus of deceased. Id. ib. pls. xxvii, xxviii, p. 64.

Plaster mask, found on male mummy. Id. ib. pl. xxxii, p. 65.

Inscribed mummy-cloths. One, id. ib. pl. xxxi [b], p. 65.

SESTEMNÜFER  I FI , Overseer of the department of tenants of the Great House, Master butcher of the Great House, etc. Dyn. VI.

Map LXI. Plan LXIII.

Wife, K̄erfet  , Royal acquaintance.

Plans, section and views, BARSANTI in *Ann. Serv.* i (1900), figs. 1-3, 5, 16 on pp. 150-2, 160; position, id. ib. ii (1901), in fig. on p. 246. See SAAD in *Chron. d'Ég.* xx (1945), p. 81 [top].

Offering-room.

(1) Doorway. (a)-(b) Lintel with offering-text, deceased seated and standing (twice).

BARSANTI, op. cit. i (1900), fig. 4, p. 151; SAAD, *Royal Excavations at Saqqara and Helwan (1941-1945)* in *Ann. Serv. Cahier*, 3 (1947), pl. xviii, pp. 56-7.

(2) (sketched above and either side of doorway) Men with jars, four registers of butchers, and deceased at table.

BARSANTI in *Ann. Serv.* i (1900), figs. 6-8, p. 153.

(3) (sketched) Deceased at either end (with wife on right), and registers (from left), I, [deceased seated], wife and daughter playing harps, and estates (no names), II, men in canoes plucking lotus-flowers and jousting, III, making net and plucking bird, and two sub-registers of tending cattle, IV, men netting fowl and bringing birds.

Id. ib. fig. 9, pp. 153-4. Man making net in III, and others pulling rope in IV, SAAD, op. cit. pl. xxiii, pp. 60-2.

(4) (sketched) Tympanum, remains of deceased spearing fish. Below, registers, I-III, offerings, IV-V, offering-bringers.

BARSANTI in *Ann. Serv.* i (1900), figs. 13, 14, pp. 158-9; see SAAD, op. cit. p. 60. I-V, id. ib. pl. xxii, p. 60.

(5) (painted) Deceased at table (offering-list blank).

Id. ib. pls. xx, xxi, pp. 59-60; BARSANTI in *Ann. Serv.* i (1900), fig. 12, pp. 156-8.

(6) False-door, with tables with jars above.

Id. ib. figs. 10, 11, p. 154; SAAD, op. cit. pl. xix, fig. 6, pp. 57-9. Some titles, SETHE, *Urk.* i. 193 [32 (123)].

(7) (sketched) Deceased seated. See BARSANTI in *Ann. Serv.* i (1900), p. 154 [bottom].

Burial chamber.

Wooden rectangular coffin, in Cairo Mus. CG 28121. DONADONI ROVERI, *Sarcofagi egizi*, Tav. xxxvii [2], pp. 161-2 [C 21]; LACAU in *Ann. Serv.* xxvi (1926), figs. 1, 2, pp. 69-74; ARCH. LACAU phot. O.i,7-8. Texts, LACAU, *Sarcophages*, ii, pp. 134-5. See BARSANTI in *Ann. Serv.* i (1900), p. 160.

Mastaba usurped by MERY-ISESI , Supervisor and Inspector of prophets of the Pyramid of Unis. Early Dyn. VI.

Map LXI. Plan LXIII.

LAUER in *Ann. Serv.* xxxvii (1937), pp. 110-11 [iv]; SMITH (W. S.) in REISNER, *Tomb Development*, p. 411.



Room I.

(1) Five estates. Names, JACQUET-GORDON, *Domaines*, p. 427 [39S6], cf. figs. 179 (plan), 180 (copied by Goedicke).

Room II.

(2) False-door.

UNIS-ḤAISHTEF ḤAISHTEF , Overseer of commissions of the Pyramid of Unis, etc. Probably Middle Kingdom.

Originally built for father Kai  Seni , Inspector of prophets of the Pyramid of Unis, etc.

Map LXI. Plan LXIII.

SAAD in *Ann. Serv.* xl (1940), pp. 685-6, with titles of deceased and father; SCHWEITZER in *Orientalia*, n.s. 17 (1948), p. 263 [upper middle]. Date, HÖLSCHER (U.) and MUNRO in *Studien zur altägyptischen Kultur*, 3 (1975), pp. 122-3.

Room I.

(1) Deceased seated, with offering-list, offering-bringers and offerings.

Three offering-bringers, VIOLLET and DORESSE, *Egypt*, pl. 59.

(2) False-door, and deceased with offering-list above. (3) Two registers of butchers.

(4) Doorway. Above, double-scene, left, deceased before grandfather Ḥaishtef-wēr, Overseer of the Two Cool Chambers, etc., right, deceased before father. Jambs, deceased.

FISCHER, *Varia*, fig. 1, p. 81. Two figures of deceased above doorway, SAAD, op. cit. fig. 74, p. 685.

(5) Offering-list, offerings, and three offering-bringers.

Room II.

(6) Doorway. (a) Two priests; (b) deceased. (7) Uninscribed false-door. (8) Deceased

seated. (9) False-door of father. (10) (much destroyed) Deceased seated. (11) Painted false-door of deceased. (12) Remains of deceased seated. (13) Remains of marsh-scene.

Burial chamber.

Offering-list. FISCHER in *Ä.Z.* 90 (1963), Taf. vii [b], p. 37.

NEFERSEHEMPTAH. End of Dyn. V or early Dyn. VI.

Map LXI.

HÖLSCHER (U.) and MUNRO in *Studien zur altägyptischen Kultur*, 3 (1975), pp. 115-17, 121, with plan on p. 126.

Two painted blocks, fig-harvest and gardening. Id. ib. Taf. i, pp. 123-5.

IYNEFERT $\text{𓆎} \text{𓆏} \text{𓆐}$, Chief Justice and Vizier. Dyn. VI.

Map LXI. Plan LXIII.

SAAD in *Ann. Serv.* xl (1940), pp. 686-7; SCHWEITZER in *Orientalia*, n.s. 17 (1948), p. 263 [middle]. Plan, HÖLSCHER (U.) and MUNRO, op. cit. on p. 126.

Room I.

(1) Doorway. (a)-(b) Lintel with eight figures of deceased, jambs with deceased and wife. (c) Deceased. (d) Three registers of baking scenes. (e) Three registers of bringing animals.

Oryx in III at (e), KEIMER, *Les limites de l'observation* [etc.] in *Annales de la Faculté des Lettres*, ii (1953), pl. xviii [1], p. 128 [7].

(2) Deceased fishing and fowling. (3) Deceased, and registers, I-II, bringing shrines and statue, III-IV, offering-bringers. (4)-(5) Fishing scene. (6) (above doorway) Two registers of musicians.

Room II. Painted decoration.

(7) Doorway. (a) and (b) Offering-bringers. (8) Offering-bringers. (9) Offering-bringers before deceased. (10) (above doorway) Two registers of servants making beds, with deceased and wife seated on left.

Room III.

(11) Doorway. (a) and (b) Two registers of men bringing animals. (12) Registers, I-V, offering-bringers, VI, butchers. (13) and (14) Three registers of offering-bringers before deceased (partly destroyed at (14)). (15) False-door.

UNIS'ANKH $\text{𓆎} \text{𓆏} \text{𓆐}$ $\text{𓆑} \text{𓆒}$, King's son, Overseer of Upper Egypt, etc. Temp. Unis.

Map LXI. Plan LXIII.

SAAD in *Ann. Serv.* xl (1940), p. 687, with some titles; SCHWEITZER in *Orientalia*, n.s. 17 (1948), p. 263 [lower middle].

Chapel.



Blocks from inner part in Chicago, Field Mus. Nat. Hist. A. 24448, QUIBELL in *Egypt Exploration Fund. Archaeological Report 1907-1908*, p. 14 [1].

Room I.

(1) Man reading from papyrus before deceased. (2) Offering-bringers.

Room II.

(3) and (6) Oil-jars. (4) and (5) Men bringing animals to deceased.

SESHSESHET  IDUT , King's daughter of his body. Dyn. VI.

Usurped from Ihy , Chief Justice and Vizier, etc. Dyn. VI.

Map LXI. Plan LXIII.

MACRAMALLAH, *Le Mastaba d'Idout*, passim; FIRTH in *Ann. Serv.* xxvii (1927), p. 107; SAAD in *ib.* xl (1940), pp. 690, 692. Plan, MACRAMALLAH, pl. ii, cf. i. Views, *id. ib.* pls. iii, iv. Texts, ČERNÝ Notebook, 118, pp. 65-78, cf. 64 verso [upper]; some, GUNN Notebooks, 14, 15.

Room I. A of Macramallah.

(1) Doorway. (a) and (b) Remains of deceased. MACRAMALLAH, pl. v [E, F], p. 7.

(2) (bottom part only) Deceased in canoe, and another smaller canoe with men (one fishing with dip-net).

Id. ib. pl. v [C], pp. 7-8.

(3) Bottom register, scribes and men bringing chiefs of estates in scene of rendering accounts.

Id. ib. pl. v [B], pp. 9-10.

(4) (bottom part only) [Deceased] in canoe, and on left, smaller canoe with men fishing with dip-net and angling, on right, [men] in canoe and netting fish.

Id. ib. pl. v [D], pp. 8-9. Canoe on left, LAUER, *Saqqara*, pl. 70. Man angling, DAUMAS in *B.I.F.A.O.* lxii (1964), pl. xi [A], cf. fig. 5 (from MACRAMALLAH), pp. 73-4; with various species of fish, DARBY, GHALIOUNGUI and GRIVETTI, *Food: The Gift of Osiris*, i, figs. 7.10, 29, 30.

Room II. B of Macramallah.

(5) Doorway. (a) and (b) Registers, **I**, offering-bringers, **II**, men dragging and censing statue.

MACRAMALLAH, pl. ix [A, B], pp. 10-11. (a) **II**, VANDERSLEYEN, *Das Alte Ägypten*, Abb. 256; LAUER, *Saqqara*, pl. 71; man pouring water and two others, SAMIVEL and AUDRAIN, *The Glory of Egypt*, pl. 26.

(6) Remains of five registers of men bringing cattle.

MACRAMALLAH, *op. cit.* pl. ix [C], p. 11.

(7) Registers before deceased in canoe, **I**, remains of canoes, **II**, herdsmen tending cattle, **III**, papyrus harvest and making canoe, **IV-V**, men with animals and birds in canoes, **VI**, men in canoes harpooning hippopotami, fishing with dip-net, and crossing canal with cattle. Registers behind deceased, **I-V**, attendants, officials and scribes, **VI**, men in canoe angling and fishing with dip-net.

Id. ib. frontispiece, pls. vi, vii, pp. 13-17. Deceased with some men before and behind her, and hippopotamus and crocodile, LAUER, *Saqqara*, pls. 72-3. Men harpooning hippopotami and fishing with dip-net, ŽÁBA, *Tesáno do kamene, psáno na papyrus*, pl. 6; man with dip-net, DAUMAS, *Civ. de l'Ég.* pl. 74. Crocodile waiting for birth of hippopotamus, *id. ib.* pl. 237; MÜLLER, *Äg. Kunst*, Abb. 43 [lower]. Butterfly, KEIMER in *Ann. Serv.* xxxiv (1934), fig. 98, p. 180. Men in canoe angling and fishing with dip-net, TOUNY and WENIG, *Sport*,

Taf. 54; man angling, DAUMAS in *B.I.F.A.O.* lxii (1964), pl. xi [B], cf. fig. 4 (from MACRAMALLAH), p. 73; three fish biting hooks, POSENER, SAUNERON and YOYOTTE, *Dict. civ.* fig. on p. 214; one, LECA, *Médecine*, fig. 96. Various species of fish, DARBY, GHALIOUNGUI and GRIVETTI, *Food: The Gift of Osiris*, i, figs. 7.11, 21, 41.

(8) Bottom register, scribes and men bringing chiefs of estates in scene of rendering accounts.

MACRAMALLAH, pl. v [A], p. 11.

(9) Remains of registers, **I-II**, offerings, **III**, men dragging shrine with coffin, **IV**, shrines at top, deceased with lector-priest and men towing [boat] before him, and [*mww*-dancers] behind him, **V-VI**, rowing-boats and men towing [boat with coffin], with erased texts of **Ihy**, **VII**, offering-bringers.

I-III (replaced later), LAUER in *Ann. Serv.* liv (1957), pls. v [1], vi [1, 2], pp. 106-7. Omitting **I-III**, MACRAMALLAH, pl. viii, pp. 11-13. Omitting **I-III** and lower part of **VII**, LÜDDECKENS in *Mitt. Kairo*, 11 (1943), Abb. 9 (from MACRAMALLAH), pp. 22-3 [6, 7]. **IV-V**, JUNKER in *ib.* 9 (1940), Abb. 4 (from MACRAMALLAH), p. 6 [c]. **VI**, short text with donkey's head sign (not shown by MACRAMALLAH), GRDSELOFF in *Ann. Serv.* xlv (1944), fig. 33, p. 302 [4]; another mentioning Ptah, SANDMAN HOLMBERG, *The God Ptah*, p. 6* [7], p. 25 [5].

Room III. C of Macramallah.

(10) Remains of bottom register, men bringing donkey herd.

MACRAMALLAH, pl. x [A], p. 19 [top].

(11) Remains of three registers, chests, and men bringing chests with ointments.

Id. *ib.* pl. x [B], p. 18.

(12) Two men making chest. Id. *ib.* pl. x [C], p. 18.

(13) Remains of three registers, men bringing gazelle, ibex and oryx.

Id. *ib.* pl. x [D], p. 18.

Room IV. D of Macramallah.

(14) Remains of offering-bringers leading calves. Id. *ib.* pl. xi [A], p. 19.

(15) Registers, **I, III-IV**, offering-bringers, **II**, men in canoe with calf.

Id. *ib.* pl. xiii [A], p. 19.

(16) (fragmentary) Deceased, and registers, **I-IV**, offerings, **V-VII**, offering-bringers.

Id. *ib.* pl. xii, p. 21.

(17) (fragmentary) Deceased with two women behind her, and registers, **I, III, V-VI**, offering-bringers, **II**, boatmen jousting, **IV**, men in canoes.

Id. *ib.* pl. xi [B], pp. 20-1. 3rd to 8th offering-bringers in **VI**, LAUER, *Saqqara*, pl. 74; 5th, DARBY, GHALIOUNGUI and GRIVETTI, *Food: The Gift of Osiris*, i, fig. 5.7. Additional blocks with text above deceased, now replaced, LAUER in *Ann. Serv.* liv (1957), p. v [2], p. 107.

(18) Above doorway, three registers of offering-bringers.

MACRAMALLAH, pl. xiii [B], pp. 19-20.

Room V. E of Macramallah.

(19) Doorway. (a) and (b) Deceased smelling lotus, with woman behind her at (b).

Id. *ib.* pl. xvi [B, A], p. 22. (b) LAUER, *Saqqara*, pl. ix.

(20) Registers, **I-V** (partly above doorway), offerings, **VI**, man tying ox, **VII**, butchers.

MACRAMALLAH, pl. xix, pp. 22-3.

(21) Deceased at table smelling ointment-jar, and offerings, offering-bringers and butchers.

Id. ib. pls. xv, xxvii, pp. 27-8. Some offerings, offering-bringers, and butchers, LAUER, op. cit. pl. viii. One offering-bringer and butchers, LANGE and HIRMER, *Ägypten. Archäitektur* (1967), pl. 72 [lower]; DARBY, GHALIOUNGUI and GRIVETTI, op. cit. figs. 3.34a, 39.

(22) Niche with false-door. (a) and (b) Five registers of chests and offering-bringers, (c) false-door.

MACRAMALLAH, op. cit. pls. xiv, xvi [C, D], pp. 28-30.

(23) Offering-list, with priests below.

Id. ib. pl. xviii, pp. 30-1. Offering-list, HASSAN, *Giza*, vi [2], pls. lxxiii-lxxx [81], p. 136.

(24) Deceased seated smelling lotus, and registers, **I-III**, offerings, **IV-V**, men bringing animals, **VI** (under whole scene), offering-bringers and butchers.

MACRAMALLAH, pl. xx, pp. 24-7. Three butchers, SAMIVEL and AUDRAIN, *The Glory of Egypt*, pl. 17; SHURINOVA, *Iskusstvo Drevnego Egipta*, pl. 14.

(25) Deceased at table smelling ointment-jar, with attendants behind her, and offerings and offering-bringers before her.

MACRAMALLAH, pl. xvii, pp. 23-4. Seshemnūfer $\text{𓆎} \text{𓆏} \text{𓆑}$, Inspector of physicians, see GALIUNGI in *Egypt Trav. Mag.* No. 109 (Sept. 1963), fig. 17 (from MACRAMALLAH) on p. 14.

Unplaced.

Fragment of marsh-scene with civet-cat giving birth; MACRAMALLAH, pl. xxvi [upper], p. 16. Remains of registers, **I**, legs of animals, **II**, hunter with dog, **III**, three men with bull, not necessarily from this tomb; texts, ČERNÝ Notebook, 118, p. 64 verso [lower]; see SMITH, *Hist. Eg. Sculp.* p. 207.

Burial chamber. Painted decoration. MACRAMALLAH, pp. 3-4, with plan and sections, figs. 1-3.

Offerings, offering-lists, and chests with feathers on top, id. ib. pls. xxi [A], xxii-xxiv, xxvi [lower], pp. 31-5. Offering-list on east wall, HASSAN, *Giza*, vi [2], pls. lxxiii-lxxx [82], p. 136.

Sarcophagus of Iḥy, usurped by deceased. MACRAMALLAH, op. cit. pls. xxi [B], xxv, pp. 4-5, 36-7.

MEḤU $\text{𓆎} \text{𓆏} \text{𓆑}$, Chief Justice and Vizier, etc. Temp. Pepy I or later.

Map LXI. Plan LXIII.

Wives, Nebt $\text{𓆎} \text{𓆏} \text{𓆑}$, Royal acquaintance, and Nefer(t)kaus $\text{𓆎} \text{𓆏} \text{𓆑}$ Iku, King's daughter of his body.

SAAD in *Ann. Serv.* xl (1940), pp. 687-90; SCHWEITZER in *Orientalia*, n.s. 17 (1948), pp. 263 [bottom]-264 [top]; *Chron. d'Ég.* xx (1945), p. 79 [middle]. Plan, HUSSEIN in *Ann. Serv.* xlii (1943), fig. 114, cf. pls. xxix-xxxiv, pp. 417-25; LAUER, *Sagqara*, fig. 10 on p. 152.

Room I.

(1) Doorway. (a) and (b) Deceased. (2) Men with papyrus.

(3) Registers of men mending nets, preparing food for fowl, netting and bringing birds.

Omitting top, id. ib. pl. 132. Preparing food and netting fowl, SCHWEITZER in *Orientalia*, n.s. 17 (1948), pl. xviii [3], pp. 263-4. Man with clap-net with cranes, ALTENMÜLLER in *Göttinger Miszellen*, No. 9 (1974), Abb. 2, pp. 15, 17.

(4) Three registers of bringing animals and birds to deceased.

(5) Deceased fowling.

Right part, birds in nests and ichneumon, MÜLLER (H. W.), *Alt-Ägyptische Malerei*, Taf. 8.

(6) Deceased with attendants before papyrus thicket. (7) Deceased spearing fish.

Room II.

View, SAAD, op. cit. pl. lxxx, p. 688; id. in *I.L.N.* Sept. 28, 1940, fig. 3 on p. 412.

(8) Doorway. (a) Four registers of baking, brewing, and roasting birds. (b) Two registers of bringing calves and milking.

(a) I, GHALIOUNGUI, *Magic and Medical Science* (1963), pl. viii [c]; incomplete, (1973), pl. 14 (reversed); 2nd and 3rd men, id. in *Ä.Z.* 87 (1962), fig. 5 on p. 112; DARBY, GHALIOUNGUI and GRIVETTI, *Food: The Gift of Osiris*, i, fig. 2.10. Man cleaning jar in II, id. ib. fig. 2.11; GHALIOUNGUI, *Magic and Medical Science* (1963), pl. viii [b]; (1973), pl. 13; id. in *Ä.Z.* 87 (1962), Taf. iii [b] after p. 110.

(b) Man carrying calf in I, id. ib. Taf. iii [a] after p. 110.

(9) Scribe, and man before granaries.

(10) Deceased, and three registers, freight-ships and sailing-boats, harvest-scenes, and estates.

Reapers and flutist in II, HICKMANN in *Bull. Inst. Ég.* xxxvi (1953-4), fig. 13, p. 598 = id. *Musicologie pharaonique*, fig. 13, p. 27; id. in *Egypt Trav. Mag.* No. 17 (Dec. 1955), fig. on pp. 32-3; one reaper, GHALIOUNGUI in *Ä.Z.* 87 (1962), fig. 4 on p. 112; id. *Magic and Medical Science* (1963), fig. 6 on p. 90; (1973), fig. 8 on p. 87. Two women winnowing, MÜLLER, *Ag. Kunst*, Abb. 50. Text and names of estates in III, JACQUET-GORDON, *Domaines*, pp. 4, 419-26 [38S6], cf. figs. 177-8; cf. ZIVIE (A.-P.), *Hermopolis et le nome de l'Ibis*, pp. 39-41 [I, C].

(11) Three registers of metal-workers, including beating, smelting and weighing.

(12) Above doorway, men in canoes.

(13) Registers before deceased, I, netting fowl, and men in canoes (including deceased), II, presenting and netting fish, III, ploughing, sowing with sheep treading grain, shepherd's song, and cattle crossing water.

Men pulling rope in I and II, GHALIOUNGUI in *Ä.Z.* 87 (1962), Taf. iii [c] and fig. 3 on p. 110; in II, id. *Magic and Medical Science* (1963), fig. 5, p. 89; (1973), fig. 7, p. 88. Turtle and fish in I, SAAD in *Ann. Serv.* xl (1940), fig. 75, p. 690; id. in *I.L.N.* Sept. 28, 1940, fig. 2 on p. 412 (upside down); BAKRY in *Studi Classici e Orientali*, xxiii (1974), pl. 8 facing p. 73. II, standing and kneeling men with fish, GHALIOUNGUI in *Ä.Z.* 87 (1962), Taf. ii [c], iii [d] after p. 110; kneeling man, id. *Magic and Medical Science* (1963), pl. viii [a]; DARBY, GHALIOUNGUI and GRIVETTI, *Food: The Gift of Osiris*, i, fig. 2.9; scribe and three men with fish, SAMEH, *Daily Life*, figs. on pp. 24 [right], 59, 137. Text of shepherd's song in III, ALTENMÜLLER in *Chron. d'Ég.* xlvi (1973), pp. 212 [6], cf. 213.

Room III.

(14) (a) (above doorway) Picking fruit. (b) Two registers of bringing a bull, and bringing gazelle and offerings. (c) Two registers of bringing an oryx, and bringing offerings.

(15) Five registers of offering-bringers.

(16) Servants making bed, and three registers of offering-bringers before deceased and wife, with three registers of attendants behind them, and registers of offering-bringers below.

Bed-making, SAMEH, *Daily Life*, fig. on p. 121 [upper].

(17) (partly above doorway) Before deceased, wine-jars, and registers, **I-II**, musicians, dancers and clappers, **III-V**, butchers.

I-II, VANDERSLEYEN, *Das Alte Ägypten*, Abb. 261; right part, HICKMANN, *45 Siècles*, pl. xvi [A]; id. in *Chron. d'Ég.* xxvi (1951), fig. 2 on p. 19. Left part of **I**, DRIOTON, *La danse dans l'ancienne Égypte* in *La Femme Nouvelle* (Cairo, Oct. 1948), fig. on pp. 26-7; of **I-II**, WOOD and DROWER, *Egypt in Colour*, pl. 10; of **I-III**, LANGE and HIRMER, *Ägypten. Architektur* (1967), pl. ix; of **II-III**, VANDIER, *Egypt. Paintings from Tombs and Temples*, pl. ix. Dancers and clappers in **II**, CASSON, *Ancient Egypt*, fig. on pp. 112-13 [lower]; one dancer, HICKMANN in *Bull. Inst. Ég.* xxxviii [3] (1956-7), fig. 15, p. 93; 2nd to 4th dancers, and clappers, SAMEH, *Daily Life*, fig. on p. 132; WENIG, *Die Frau*, pl. 19; 2nd to 4th dancers, with butchers below in **III**, DESROCHES-NOBLECOURT, *Egyptian Wall-Paintings from Tombs and Temples*, pl. 3.

(18) Registers, **I-III**, offerings before deceased, **IV-VI**, offering-bringers leading animals.

Part of **V-VI**, LANGE and HIRMER, op. cit. pl. viii [upper]. Moufflon in **V**, KEIMER, *Les limites de l'observation* [etc.] in *Annales de la Faculté des Lettres*, ii (1953), pl. xiii [1], pp. 125-6 [2]. Two offering-bringers in **VI**, VANDIER, op. cit. pl. x; DESROCHES-NOBLECOURT, op. cit. pl. 1.

Offering-room IV. Meḥu. View, LAUER, *Saqqara*, pl. xix.

(19) Doorway. (a) and (b) Man censing and another offering birds to deceased. (20) Registers, **I-III**, offerings, **IV**, offering-bringers, **V-VII**, butchers.

(21) and (22) Deceased at table, with offering-list and **I-III**, offerings, **IV**, priests, **V-VII**, offering-bringers.

(21) Some animals and offering-bringers, KEIMER, op. cit. pls. xvi [1, 2], xvii [2], pp. 127-8 [4-6].

(22) Central part, SAAD in *I.L.N.* Sept. 28, 1940, fig. 7 on p. 413. Men with birds and cages of birds in bottom register, LAUER, *Saqqara*, pl. xx; LANGE and HIRMER, *Ägypten. Architektur* (1967), pl. viii [lower]; three, VANDIER, *Egypt. Paintings from Tombs and Temples*, pl. viii; DESROCHES-NOBLECOURT, *Egyptian Wall-Paintings from Tombs and Temples*, pl. 2.

(23) False-door.

SAAD in *I.L.N.* Sept. 28, 1940, fig. 5 on p. 413; id. in *Ann. Serv.* xl (1940), pl. lxxxi, p. 690; OTTO and HIRMER, *Osiris und Amun*, pl. 3; SMITH (J. L.), *Tombs, Temples, and Ancient Art*, pl. facing p. 128.

Offering-room V. Meryrēc-cankh , Inspector of prophets of the Pyramid of Pepy I. Temp. Pepy I or later.

(24) Bull.

(25) Registers, **I-IV**, offerings, **V**, offering-bringers, **VI-VII** (right of doorway), tied-up animals and butchers.

Two men overthrowing ox, LAUER, *Saqqara*, pl. 134.

(26) and (27) Meryrēc-cankh at table, with offering-list, priests, offerings, and offering-bringers.

(26) Central part, LAUER, *Saqqara*, pl. 133. Three offering-bringers in bottom register, VANDERSLEYEN, *Das Alte Ägypten*, Abb. xxiii. Ancient correction of title, FISCHER in *Metropolitan Museum Journal*, 9 (1974), fig. 1, pp. 5-6.

(27) Left part, LAUER, *Saqqara*, pl. xviii (reversed). Three men carrying haunches in bottom register, SAMEH, *Daily Life*, fig. on p. 65 [lower]. Bullock and man with geese below, MÜLLER (H. W.), *Alt-Ägyptische Malerei*, Taf. 9; VANDIER, op. cit. pl. vii; SHURINOVA, *Iskusstvo Drevnego Egipta*, pl. 22. Two offering-bringers with antelope, KEIMER, op. cit. pl. xiii [2], p. 125 [1].

(28) False-door of Meryrē-cankh.

VI. Court.

(29) (painted) An offering-bringer and offerings before deceased, and offering-bringers below. (30) False-door of son Kaḥotp $\text{𓂏} \frac{\text{𓂏}}{\text{𓂏}}$, Overseer of the *gs-pr*, etc., with painted vases right of it. (31) (painted) Four registers of gardening.

(32) and (33) Pillars. On all faces, deceased (erased on north face of (33)).

Inscribed architrave above, HUSSEIN in *Ann. Serv.* xlii (1943), pl. xxxv, p. 424.

IARTI $\frac{\text{𓂏}}{\text{𓂏}}$ $\frac{\text{𓂏}}{\text{𓂏}}$, Inspector of prophets of the Pyramid of Unis, Overseer of tenants of the Great House, etc. Middle Dyn. VI or later.

Map LXI.

Father, probably Iy (tomb, see *infra*).

False-door. SAAD in *Ann. Serv.* xl (1940), fig. 73, p. 683.

ḶANKHI $\frac{\text{𓂏}}{\text{𓂏}}$ $\frac{\text{𓂏}}{\text{𓂏}}$, Prophet of the Pyramid of Unis, Overseer of tenants, Noble of the King, etc. Late Dyn. VI.

East of last tomb.

False-door. Name and titles, ALTENMÜLLER in *Studien zur altägyptischen Kultur*, 1 (1974), p. 6 [6].

SNEFRUḤOTP $\left(\frac{\text{𓂏}}{\text{𓂏}} \frac{\text{𓂏}}{\text{𓂏}} \right) \frac{\text{𓂏}}{\text{𓂏}}$. Dyn. VI.

East of last tomb.

False-door.

NENGEM $\frac{\text{𓂏}}{\text{𓂏}}$ $\frac{\text{𓂏}}{\text{𓂏}}$, Royal chamberlain, Inspector of scribes of sacrificial cattle. Dyn. VI.

East of last tomb. Plan LXIV.

Façade.

(1)-(2) Deceased, and two lines of text.

Hall.

Pillars with titles of deceased on three faces. Two epithets and name, FISCHER in *Metropolitan Museum Journal*, 11 (1976), pp. 9, 12 note 37.

Inner hall.

(3) False-door.

BIA  IRERY , Noble of the King, Companion of the house. End of Dyn. VI.

South-east of tomb of Meḥu.

Wife, Idut , Prophetess of Ḥathor.

Lintel, address and offering-texts, below, double-scene, deceased and wife at table on left, deceased at table with daughter(?) Iti  on right, and sons censuring and offering, and under chairs, daughter as harpist on left, [dog] on right. Right part with Herzer (dealer) at one time.

FISCHER in *J.A.R.C.E.* iv (1965), pl. xxix, pp. 49–52. Left part, WILSON in *J.N.E.S.* xiii (1954), fig. 1, cf. 2, pp. 245 [B], 256–8 [B], 263–4; EDEL in *Ä.Z.* 83 (1958), Abb. 1 (from WILSON), pp. 3–9. Right part (without right bottom corner), *Objets*, 4/5, fig. on 103rd p.; *Antike Kunst*, 14 [I] (1971), fig. on p. ix; *Apollo*, xcii [106] (Dec. 1970), Advertisements, fig. on p. 99; ALTENMÜLLER in HORNBOSTEL and others, *Kunst der Antike* (1977), No. 3 with fig.

Jamb with deceased, and smaller figures of son Meḥu  behind him and a man and woman before him. WILSON, op. cit. pl. xviii [B], pp. 245 [C], 258 [C]; SAAD in *Ann. Serv.* xl (1940), fig. 78, p. 692 (referred to as fig. 77).

Block with offering-texts, and below, deceased leaning on staff, with wife and sons, and again standing behind. Id. ib. fig. 77, p. 692 (referred to as fig. 78); WILSON, op. cit. pl. xviii [A], cf. fig. 2, pp. 243, 245 [A], 247, 249–56 [A].

False-door, inscribed on both faces (one unfinished). Id. ib. figs. 3, 4, cf. 2, pp. 245, 247 [D], 258–9 [D]; one face, SAAD, op. cit. fig. 76, p. 690.

TWIN-MASTABA.

Map LXI. Plan LXIV.

BIEGER, MUNRO and BRINKS in *Studien zur altägyptischen Kultur*, 1 (1974), pp. 34–54, with plan, Abb. 1, cf. map on p. 34.

(a) KHENUT . (Probably wife of Unis.) Dyn. V.

SAAD in *Ann. Serv.* xl (1940), pp. 684–5; SCHWEITZER in *Orientalia*, n.s. 17 (1948), p. 263 [near top]; *Chron. d'Ég.* xx (1945), p. 79 [near top]. Plan, JACQUET-GORDON, *Domaines*, fig. 158 on p. 396.

Room I.

(1) Doorway. (a) and (b) Deceased. (2) Remains of two registers, men bringing cattle. (3) Deceased, and registers, I, remains of men walking and running, II, men in boats with punt-poles, III, offering-bringers, IV, men in canoes, with fish and hippopotamus below.

(4) Two registers, offering-bringers and estates.

Names of estates, JACQUET-GORDON, op. cit. p. 396 [26S5], cf. figs. 158–9.

(5) Registers, I, men pulling [net with birds], II, men carrying bundles of papyrus, III, thicket with flying birds and ichneumon, IV, men in boats fishing, with fish and crocodile below.

Room II.



(6) Deceased, followed by three registers of attendants, and registers before her, I, harvest-scenes, II, four boats with sacks of corn, III, three groups of men dragging chests with feathers on top, and man pouring water.

Text of chests in **III**, MUNRO in *Studien zur altägyptischen Kultur*, 1 (1974), p. 49 [bottom].

(7) Registers, **I**, man before tree, **II**, offering-bringers. (8) Remains of two bulls.

Court III.

False-door of deceased, lying on ground.

(b) NEBT   , King's wife (of Unis), Companion of Horus, etc. Temp. Unis.

SAAD in *Ann. Serv.* xl (1940), pp. 683-4; *Chron. d'Ég.* xx (1945), pp. 78 [bottom]-79 [top].

Room I.

(1) Thickness of entrance doorway, deceased. (2) (upper part lost) Deceased spearing fish, with men in canoes. (3) Bottom register with cattle ploughing, and remains of destroyed scene above. (4) Deceased in destroyed marsh-scene.

(5) (partly above doorway) Deceased, and registers of men with birds and fish.

Deceased, SAAD, *op. cit.* pl. lxxviii, p. 683; *id.* in *I.L.N.* Sept. 28, 1940, fig. 6, p. 413; SCHWEITZER in *Orientalia*, N.S. 17 (1948), pl. xvi [1], p. 262; LAUER, *Saqqara*, pl. 131.

Room II.

(6) (above doorway) Three registers of picking fruit, trees, and men with fruit. (7) Four registers, **I**, destroyed, **II**, pressing wine, **III-IV**, bringing grapes.

(8) Deceased, with four registers of female attendants behind her, including female dwarf in bottom register, and four registers of bringing wine before her.

Deceased, and parts of registers, SAAD in *Ann. Serv.* xlii (1943), pls. xiv, xv, p. 152. Two attendants and dwarf behind deceased in **IV**, *id.* *ib.* xl (1940), pl. lxxix, p. 683; ALDRED in PIGGOTT, *The Dawn of Civilization*, pl. on p. 120 [53]. Texts of bringing wine, MUNRO in *Studien zur altägyptischen Kultur*, 1 (1974), pp. 48-9.

(9) Deceased, with three registers of female attendants behind her, and registers before her, **I**, ploughing and sheep treading grain, with shepherd's song, **II**, milking, and cow calving, **III**, bringing wine on sledge, **IV**, offering-bringers.

Text of shepherd's song, ALTENMÜLLER in *Chron. d'Ég.* xlvi (1973), pp. 212 [5], *cf.* 213; MUNRO, *op. cit.* p. 49 note 14.

(10) (partly above doorway) Deceased, and four registers of female estates and offering-bringers.

Passage III.

(11) (partly above doorway) Tending and milking cattle. (12) and (14) Deceased, and four registers, men in canoes and offering-bringers. (13) and (15) Deceased, with four registers of bringing animals before her, and three registers of female attendants and offerings behind her. (16) (partly above doorway) Furniture and bed-making.

Room IV.

(17) and (18) Five registers of offering-bringers.

(19) Four statue-niches.

SCHWEITZER in *Orientalia*, N.S. 17 (1948), pl. xvii [2], p. 262.

Room V.

(20) A man seated before [destroyed scenes], and below, two remaining registers of offering-bringers.

Names and titles of sons, MUNRO, op. cit. p. 50 [bottom].

(21) Bottom register, butcher.

Room VI.

(22) Thickness of doorway, offering-bringers. (23) Three registers of butchers, and remains of offerings at top. (24) and (25) (latter mostly destroyed) Deceased at table, with offering-list, priests, and offering-bringers. (26) Remains of false-door.

Room VII.

(27) Doorway. (a) and (b) Dragging oil-jars. (28) Oil-jars. (29) Remains of two offering-bringers.

Court VIII.

(30) False-door of deceased. FISCHER in *J.E.A.* 60 (1974), fig. 1, p. 94 note 3.

Finds

Lower part of statuette with names of Unis, steatite. Names, SAAD in *Ann. Serv.* xl (1940), p. 684.

IY , Tenant of the Pyramid of Pepy I, Companion of the house, Noble of the King. Temp. Pepy I or later.

Map LXI.

Father, Ni'ankh-pepy (tomb, see *infra*).

Name and titles from jamb of doorway, ALTENMÜLLER in *Studien zur altägyptischen Kultur*, 1 (1974), pp. 5-6 [4].

KHENU , Tenant of the Pyramid of Unis, Noble of the King of the Great House, etc. Late Dyn. VI or Middle Kingdom.

Map LXI. Plan LXIV.

Views, ELSTNER, *Egypt. The Gift of the Nile*, pl. 37; MICHAŁOWSKI, *Piramidy i mastaby*, pl. 63. Name and titles, ALTENMÜLLER in *Studien zur altägyptischen Kultur*, 1 (1974), pp. 6-7 [7]. Block with name and deceased seated, formerly at Galerie G. Maspéro, Paris, now in Detroit, Institute of Arts, 72.224; *Objets*, 3, fig. on 15th page after p. 55 (advertisement); see *The Art Quarterly*, xxxv (1972), p. 318.

(1) Address, and deceased adoring, with small son Sienunis , and at table, with small son Ihy.

HELCK, *Geschichte des Alten Ägypten*, Taf. ii [7]; DAVID, *The Egyptian Kingdoms*, fig. on p. 17. Upper part of deceased at table, VIOLETT and DORESSE, *Egypt*, pl. 60. Address, ALTENMÜLLER, op. cit. fig. on p. 15, cf. pp. 14-18; part, WILD in *B.I.F.A.O.* lviii (1959), p. 110 note 1.

(2) Deceased at table.

(3) False-door. MICHAŁOWSKI, op. cit. pl. 75.

(4) Deceased seated, and offerings. (5) Low wall. Deceased seated.

(6) Pillar. (a), (b) and (c) Titles, and deceased adoring (with son Sienunis at (a)).

(a) SCHWEITZER in *Orientalia*, n.s. 17 (1948), pl. xix [4], p. 264; SCHOTT, *Zur Krönungstitulatur der Pyramidenzeit* in *Nachr. Göttingen* (1956), No. 4, Taf. iii, p. 66; DAVID, op.

cit. fig. on p. 52; see FISCHER in CAMINOS and FISCHER, *Ancient Egyptian Epigraphy and Palaeography*, p. 39 with fig. 3.

(7) Pillar. (a) Remains of scene similar to those at (6). (8) Pillar. (a) Priest (not finished). (9) False-door.

ISI Dyn. VI.

Map LXI.

Parts of address, WILD in *B.I.F.A.O.* lviii (1959), p. 110; FISCHER in *J.A.R.C.E.* iv (1965), p. 51.

HERIMERU MERERY , Prophet and tenant of the Pyramid of Unis, etc. End of Dyn. VI.

Map LXI. Plan LXIV.

Wife, Wazkaus , Prophetess of Hathor in all her places, and of Neith, etc.

HASSAN, *Mastabas of Princess Hemet-Rc and Others*, pp. 69-81, with plans and section, figs. 36, 43, and view, pl. lii.

Façade.

(1) and (2) False-doors, (1) of deceased, (2) of wife.

Id. ib. pls. liii-iv, figs. 37a, b, 38a, b, pp. 71-5.

(3) Doorway. Lintel with conventional biographical text, address, and deceased and wife, and jambs with name and titles.

Id. ib. pl. lvi, figs. 39-41, pp. 75-8. Name and titles from lintel, ALTENMÜLLER in *Studien zur altägyptischer Kultur*, 1 (1974), p. 4 [1]; parts of address, CLÈRE in *J.E.A.* 25 (1939), p. 216; id. in *Rev. d'Ég.* iv (1940), p. 116 [6].

Offering-room.

(4) Deceased in canoe spearing fish, accompanied by wife and probably son.

HASSAN, op. cit. fig. 42, pp. 78-9.

Finds from burial chamber

Ointment-slab, inscribed, alabaster. Id. ib. pl. lvii [A], pp. 80-1 [1].

Fragments of head-rest, inscribed, alabaster. Id. ib. pl. lvii [B, C], p. 81 [2].

PTAḤSHEPSES IMPY Dyn. VI.

Map LXI. Plan LXIV.

Titles, FISCHER in *Mitteilungen des Instituts für Orientforschung*, vii (1960), p. 304 note 9. Scenes with offering-bringers, see FIRTH in *Ann. Serv.* xxx (1930), p. 187.

Burial chamber of deceased.

Alabaster jar-lids, one of Pepy I, one of Nemtiemsaf (Merenrē^c) I, and three of Pepy II. See id. ib. p. 187.

Burial chamber of Khui Dyn. VI.

Alabaster slab in altar. Remains of offering-text, id. ib. p. 187.

Exterior.

(1) Khui, Judge and Keeper of Nekhen, and bottom of eight columns of text, including name of Ptahshepses and wife Ti 𓆎 .

Outer room.

(2) Khui.

Inner room.

(3) and (4) Two registers of offering-bringers. (5) Pillar. (a) and (d) Impy, (b) Khui, (c) eldest son.

NIANKH-PTAH 𓆎 𓆎 𓆎 , Secretary of all works, Prophet of the Pyramid of Unis. Dyn. VI.

Map LXI. Plan LXIV.

Plan, JACQUET-GORDON, *Domaines*, fig. 164 on p. 404.

(1) Doorway. (a) and (b) Deceased.

(2) Registers, I, estates, II-III, butchers.

Names of estates, JACQUET-GORDON, *op. cit.* pp. 404-5 [30S6], cf. figs. 164-5.

(3) Offering-list and deceased seated. (4) False-door.

(5) Deceased seated, with dog under chair, and six sons below.

Name of dog, FISCHER in *J.E.A.* 47 (1961), p. 152 [51].

NEBKAUHOR 𓆎 𓆎 𓆎 IDU 𓆎 𓆎 , Chief Justice and Vizier, King's eldest son of his body, Inspector of prophets of the Pyramid of Unis, etc. Dyn. VI.

Usurped from Akhtihotp 𓆎 𓆎 Hemi 𓆎 𓆎 , Chief Justice and Vizier, etc., end of Dyn. V or early Dyn. VI.

Map LXI. Plan LXIV.

HASSAN, *The Mastaba of Neb-Kaw-Her* (hereafter *Mastaba*), with plans and section, figs. 1, 23, and views, pls. i, ii [A], iv [A], xlvi, xlvii, xlviii [B, C]; id. in *Ann. Serv.* xxxviii (1938), pp. 512-14, 519 [6]; *Archiv aeg. Arch.* 1 (1938), pp. 177-80 [6] = *Chron. d'Ég.* xiii (1938), pp. 280-2 [6].

Façade.

(1) (a)-(b) Remains of figure of Akhtihotp at (a), with lintel with figures of Nebkauhor above.

HASSAN, *Mastaba*, pls. iii, li [B, C], figs. 24-5, pp. 6, 61-2 [3, 4].

I. Vestibule.

(2) Doorway. Two registers, dragging two statues in each.

Id. ib. pl. iv [B], pp. 6-7.

(3) Fish, from destroyed scene of netting fish.

Id. ib. pl. v [A], p. 8.

(4) Remains of fish, hippopotami, and crocodile.

Id. ib. pl. v [C], p. 8.

II. Pillared hall. View, id. ib. pls. ii [B], iv [C].

Pillars with deceased with titles above on all sides, and two architraves with deceased represented several times.

Id. ib. pls. v [B], vi-x, pp. 8-16. Titles, id. in *Ann. Serv.* xxxviii (1938), p. 512.

(5) [Deceased fowling with throw-stick], with registers of men bringing fowl behind him.

Id. *Mastaba*, pl. xxv [A, C, D], pp. 37-8.

(6) Text of will, with [deceased] below followed by officials.

Id. ib. pls. xxv [B], xxvi-xxx, figs. 17, 18, pp. 37, 38-44; GOEDICKE, *Rechtsinschriften*, Taf. ix, x, pp. 81-103 (as Taf. vii, vi [b]); GRDSELOFF in ČERNÝ Notebook, 120, pp. 80 verso, 81, 109-15. See HASSAN in *Ann. Serv.* xxxviii (1938), pp. 513 [bottom]-514 [top].

(7) Deceased seated, with name and titles, and registers, I-III (lost), IV, musicians and two men playing draughts, V, dancers and clappers, VI (below whole scene), offering-bringers and cooks (continued at (8)).

Id. *Mastaba*, pls. xi-xiii, xiv [B], figs. 2, 3 [left], 6, 7, pp. 16-19, 24-6, 28. IV-VI, HICKMANN, 45 *Siècles*, pl. xxi; ČERNÝ MSS. 2.96A (photo.). Offering-bringers and cooks in VI, *I.L.N.* June 4, 1938, figs. 4, 5 on p. 1000.

(8) Registers, I-II (much destroyed), offerings, III (much destroyed), butchers, IV, lector-priest and *mww*-dancers, men carrying chest, and offering-bringers, V, offerings, embalming-house, lector-priests, men towing boat with coffin and mourners, and butchers, VI, offering-bringers.

HASSAN, *Mastaba*, pls. xiv [A], xv-xviii, figs. 3 [right], 4, 5, 8-11, pp. 19-24, 26-8; ČERNÝ MSS. 2.96B (photo.). Parts of IV-V, JUNKER in *Mitt. Kairo*, 9 (1940), Abb. 1, pp. 1-2 [a]; HASSAN, *Gîza*, iv, figs. 33, 39 on pp. 72, 84. Lector-priest and *mww*-dancers in IV, *Archiv aeg. Arch.* 1 (1938), fig. 1, p. 179; *I.L.N.* June 4, 1938, fig. 2 on p. 1000. V, omitting offerings and butchers, HASSAN in *Ann. Serv.* xxxviii (1938), pl. xcvi [B], p. 513.

(9) [Deceased], and registers of officials and scribes, flax-harvest, ploughing and sowing with sheep treading in grain, papyrus harvest, making papyrus canoes, and netting and cutting out roes of fish.

Id. *Mastaba*, pls. xxi-xxiv, figs. 15, 16, pp. 32-7. Making canoe and cutting out roes of fish, *I.L.N.* June 4, 1938, fig. 3 on p. 1000; cutting out roes, KEIMER in *Bull. Inst. Ég.* xxi (1938-9), pl. iii, pp. 221-2 [3].

(10) Remains of deceased, and men plucking papyrus, filling water-pool, bringing baskets of grapes, felling trees and carrying log, and hunting-scene.

HASSAN, *Mastaba*, pls. xix, xx, figs. 12-14, pp. 28-32.

III. Antechamber.

(11) Thickness of doorway. Upper parts of offering-bringers.

Id. ib. pl. xxxi [A], p. 44.

(12) Remains of offering-bringers before deceased (probably) and a smaller figure of man.

Id. ib. pl. xxxi [C], fig. 19, pp. 44-5.

(13) Remains of scene similar to (12). See id. ib. p. 44.

(14) Registers, I, offering-bringers, II, men with wine-jars.

Id. ib. pl. xxxii [A], pp. 45-6.

IV. Offering-room.

(15) Doorway. (a) and (b) registers, I, offering-bringers, II, overthrowing bull.

Id. ib. pls. xxxii [B], xxxiii [A], pp. 46-7.

(16) Two remaining registers of butchers.

Id. ib. pls. xxxiii [B], xxxiv [A], pp. 47-8.

(17) and (18) (much destroyed) Deceased at table, offering-list, offerings, and offering-bringers.

Id. ib. pls. xxxiv [B], xxxv-xxxix, fig. 20, pp. 48-52. Offering-list at (18), id. *Giza*, vi [2], pls. lxxiii-lxxx [85], p. 137.

(19) Remains of false-door, with uninscribed offering-table.

Id. *Mastaba*, pls. xl, xli [A], p. 52.

V. Store-room.

(20) Doorway. (a) and (b) Two registers of men dragging jars of wine on sledges.

Id. ib. pl. xli [B, C], p. 53.

(21) Jars and chest, with men dragging jars below.

Id. ib. pl. xlv, fig. 21, p. 53.



(22) and (23) Deceased, and remains of four registers of men carrying chests and jars of oil, or dragging them on sledge.

Id. ib. pls. xlii, xliii, fig. 12, pp. 53-5, 55-6.

(24) Registers of jars and chests, and men carrying jars of wine and chest.

Id. ib. pl. xlv, p. 55.

VIII. Store-room.

Block mentioning Bebi , Inspector of *ka*-servants, etc., and Imy , Supervisor of *ka*-servants, from above doorway. Id. ib. pl. xlviii [D], p. 59; text, id. in *Ann. Serv.* xxxviii (1938), p. 514 [bottom].

Burial chamber.

Sarcophagus, usurped from Akhtihotp. Id. *Mastaba*, pl. xlix, pp. 57-8; see id. in *Ann. Serv.* xxxviii (1938), p. 519 [top].

Finds

Two blocks, one with part of biographical text of Akhtihotp. Id. *Mastaba*, pls. 1, li [A], pp. 60-1 [1, 2].

NIANKHBA , Chief Justice and Vizier, etc. Dyn. VI.

Map LXII.

HASSAN, *Mastabas of Princess Hemet-Rc and Others* (hereafter *Mastabas*), pp. 41-8, with plan, fig. 25, and views, pls. xxvi [A], xxxi [A, C]; id. in *Ann. Serv.* xxxviii (1938), pp. 506-8 [4]; *Archiv aeg. Arch.* 1 (1938), pp. 176-7 [4] = *Chron. d'Ég.* xiii (1938), pp. 279-80 [4].

Head and feather, perhaps Late Period, on wall of east offering-room. HASSAN, *Mastabas*, pl. xxxi [B], p. 43.



Main burial chamber.

Sarcophagus, with name and titles in ink. Id. ib. pl. xxx, p. 45; text, id. in *Ann. Serv.* xxxviii (1938), p. 507.

Offerings, funerary equipment, etc., painted on walls. Id. *Mastabas*, pls. xxvi [B], xxvii-xxix, pp. 45-8; titles, from west wall, id. in *Ann. Serv.* xxxviii (1938), p. 508.

False-doors nearby. Late Dyn. VI.

(a) Ihy , Inspector of tenants of the Great House. (b) Khentkauhor ,

King's son, Elder of the *is*-chamber in the Two Houses, etc.; GUNN MSS. xviii. 55 (photos.).
(c) Nītankh-khnum  Khnemi , Inspector of tenants of the Great House, etc.

IYENḤOR , Lector-priest of the *mit*-bark of Horus and the *d:t*-bark of Horus, etc. End of Dyn. VI.

Map LXI.

Wife, Theset , Royal acquaintance.

HASSAN, *Mastabas of Princess Ḥemet-Rc and Others*, pp. 59–67, with plans and section, figs. 32, 35, and view, pl. xlv.

Doorway. Two lintels with offering-texts. Id. *ib.* pls. xlvi–xlvi, fig. 33, pp. 60–2; 1st line of upper lintel, ALTENMÜLLER in *Studien zur altägyptischen Kultur*, 1 (1974), pp. 4–5 [2].

False-door. HASSAN, *op. cit.* pls. xlix, 1, figs. 34b, cf. a, pp. 62–6; two titles, see FISCHER in *A.Z.* 86 (1961), p. 24 [middle].

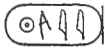
NI'ANKH-PEPY  NI'ANKH-MERYRĒ' , Overseer of commissions of tenants of the Pyramid of Pepy I, etc. End of Dyn. VI. (Usurped tomb.)

Map LXII.

Wife, Kēdi .

HASSAN, *Mastabas of Ny-cankh-Pepy and Others* (hereafter *Mastabas*), pp. 1–23, with plan, fig. 1; id. in *Ann. Serv.* xxxviii (1938), pp. 508–12 [5]; *Archiv aeg. Arch.* 1 (1938), p. 177 [5] = *Chron. d'Ég.* xiii (1938), p. 280 [5].

Offering-room. Rock-cut.

Doorway. Lintel with offering-texts, jambs with deceased and family, and address and threat. Graffito, probably of 1st Int. Period, on right jamb.

HASSAN, *Mastabas*, pls. i–iv, figs. 2–5, pp. 4–11. Texts, ČERNÝ Notebook, 120, pp. 79–80, 107–8 (by Grdseloff). Name and titles, ALTENMÜLLER in *Studien zur altägyptischen Kultur*, 1 (1974), p. 5 [3]. Graffito, DRIOTON in *Archiv Orientalní*, xx (1952), pl. xxxvi, pp. 352–5 with fig. See HASSAN in *Ann. Serv.* xxxviii (1938), pp. 508 [bottom]–509 [top].

North wall. Offering-list on slab in recess, HASSAN, *Mastabas*, pl. v [A], fig. 6, pp. 11–15; *Giza*, vi [2], pls. cvi–cxiv [115], p. 145.

False-door. Id. *Mastabas*, pl. v [B], fig. 7, pp. 15–16.

Burial chamber. Plan and section, id. *ib.* fig. 8.

Four seated statuettes of deceased. Id. *ib.* pls. vi–xi, pp. 17–19; id. *Giza*, v, pl. ix, p. 50; *I.L.N.* June 4, 1938, fig. 7 on p. 1001; texts, HASSAN in *Ann. Serv.* xxxviii (1938), pp. 509–10.

Two squatting female statuettes. Id. *Mastabas*, pl. xxiii [A–C], p. 23. See id. in *Ann. Serv.* xxxviii (1938), p. 510 [middle].

Inscribed wooden coffin and grid. Id. *Mastabas*, pls. xii–xx, figs. 9–11, pp. 19–22. Offering-list on inner east side of coffin, id. *Giza*, vi [2], pls. cvi–cxiv [116], p. 145. See id. in *Ann. Serv.* xxxviii (1938), p. 510 [near bottom].

Head-rest of deceased, inscribed, alabaster. Id. *Mastabas*, pl. xxi, p. 22; *I.L.N.* June 4, 1938, figs. 1, 3 on p. 1001. Names and titles, HASSAN in *Ann. Serv.* xxxviii (1938), p. 511.

KAIRER $\sqcup \supseteq$. Temp. Unis or Dyn. VI.

Map LXII. Plan LXV.

LAUER in *Ann. Serv.* xxxvii (1937), pp. 107-9 [II]. Name of dog from a reused block, FISCHER in *J.E.A.* 47 (1961), p. 153 [62].

Two inscribed obelisks. MARTIN (K.), *Ein Garantsymbol des Lebens*, p. 226 [40] with Abb. 7 on p. 237.

Room I.

(1) Bottom of scene of netting fish, with crocodile and hippopotamus.

Crocodile laying eggs, LAUER, *Saqqara*, pl. 67.

(2) At bottom, estates.

GUNN MSS. xix. 37 (photo.). Names, JACQUET-GORDON, *Domaines*, pp. 428-9 [40S6], cf. figs. 181-2; cf. ZIVIE (A.-P.), *Hermopolis et le nome de l'Ibis*, p. 28 [I, B].

(3) [Deceased], and small figures of wife and son. (4) (a) and (b) Deceased.

(5) Registers, I, cooking, II, cutting open fish, III, bringing fish in baskets on yoke.

GUNN MSS. xviii. 57 [I] (photo.).

Room II.

(6) Doorway. (a) Registers, I, two men bringing bull, II, herdsmen and calves. (b) Registers, I, calving, II, milking.

(b) GUNN MSS. xviii. 57 [2] (photo.).

(7) Registers, I (almost completely lost), musicians, II-III, flutists and singers, IV, draughts-players.

LAUER, *Saqqara*, pl. 69. II-III, HICKMANN, *Abrégé de l'histoire de la musique en Égypte* in *Revue de Musicologie*, xxxii, n.s. Nos. 93-4 (July 1950), pl. facing p. 8; id. *45 Siècles*, pl. xv [B]; id. in BLUME, *Die Musik in Geschichte und Gegenwart*, Abb. 27, col. 326.

(8) Registers, I, boats (one towed), II, fowl-house, with men feeding geese and cranes.

GUNN MSS. xviii. 58-60 (photos.).

(9) Registers before deceased and wife, I, making statues and jewellery, II, metal-workers, including weighing-scene, and scribe.

Jewellers in I, and weighing-scene in II, LAUER, *Saqqara*, pl. 68; weighing, SMITH, *Art . . . Anc. Eg.* pl. 51 [A], pp. 76-7; GUNN MSS. xviii. 56 (photo.).

(10) (a) and (b) Two offering-bringers.

Room III.

(11) Two registers of men dragging jars on sledges before deceased. (12) Double-scene, deceased and family spearing fish and fowling, with four registers of bringing cattle behind them, and men with bread beyond. (13) Offering-bringers, officials, defaulters, etc. (14) Four registers of offering-bringers.

Room IV.

(15) Doorway. (a) and (b) Bringing bull.

GUNN MSS. xviii. 61 [2, 3] (photos.).

(16) Two registers of offering-bringers.

(17) Remains of offering-bringers before deceased at table.

Remains of offering-list, probably from here, HASSAN, *Gîza*, vi [2], pls. cvi-cxiv [117], p.

145.

(18) Registers, I, remains of offering-bringers, II-IV, butchers.

Room V.

False-door of Ihy $\text{𓆎} \text{𓆎} \text{𓆎} \text{𓆎}$, Lector-priest, etc., probably Dyn. VI, not *in situ*. See LAUER in *Ann. Serv.* xxxvii (1937), p. 109.

Burial chamber.

Two 𓆎 shaped blocks with name, schist. Id. ib. fig. 2, pp. 108-9.

MITRI $\text{𓆎} \text{𓆎}$ (or $\text{𓆎} \text{𓆎} \text{𓆎}$), Boundary official, Prophet of Ma'et, etc. End of Dyn. V or early Dyn. VI.

Map LXII.

Wife, . . . menkaurē . . . $\text{𓆎} \text{𓆎} \text{𓆎} \text{𓆎}$ Prophetess of Ḥathor Mistress of the Sycamore, etc. Architrave fragment. GUNN MSS. xviii. 62 [3] (photo.).

Wooden statues.

ARCH. LACAU photo. F.ii. View of serdab with statues *in situ*, ZAYED, *Trois études d'égyptologie*, fig. 11, p. 15; SMITH, *Art . . . Anc. Eg.* pl. 52 [B], p. 77. See id. *Hist. Eg. Sculp.* p. 60.

New York, M.M.A. See *M.M.A. Bull.* xxiii (1928), p. 92.

Deceased and wife, carved separately, Nos. 26.2.2, 3. HAYES, *Scepter*, i, fig. 64, p. 110; SCOTT, *Egyptian Statues* (1945), 2nd pl.; *I.L.N.* Dec. 29, 1945, figs. on pp. 724 [lower right], 725 [lower left]; MICHALOWSKI, *Art*, fig. 228; POULSEN, *Åg. Kunst. A. und M.* pl. on p. 69; ALDRED, *O.K. Art*, pl. 45; *Guide to the Collections. Egyptian Art* (1962), fig. 10. No. 26.2.2, PIJOÁN, *Summa Artis*, iii (1945), fig. 215.

Deceased (without wig), legs lost, No. 26.2.4. HAYES, *op. cit.* i, fig. 65, p. 110; BRECKENRIDGE, *Likeness. A Conceptual History of Ancient Portraiture*, fig. 18.

Deceased seated, No. 26.2.6. Id. ib. fig. 19; ZAYED, *op. cit.* fig. 12 [left] (*in situ*), p. 15; PIJOÁN, *op. cit.* fig. 220.

Wife, legs lost, No. 26.2.5.

Cairo Museum.

Wife, JE 51738. Upper part, FIRTH in *Ann. Serv.* xxvi (1926), pl. v, p. 101.

Hunchback, JE 52081. MÜLLER (H.) in *Mitt. Kairo*, 7 (1937), Taf. 19, p. 104; ENGELBACH in *Ann. Serv.* xxxviii (1938), pl. xxxvii [2], p. 285; CAPART, *Documents*, ii, pl. 21; id. *Memphis*, fig. 335; PIJOÁN, *op. cit.* fig. 169 (as Dyn. IV); WOLF, *Kunst, Abb.* 155; AUBERJONIS in *Scope*, iv [6] (Summer 1955), fig. on p. 10 [lower]; RIAD, *La Médecine au temps des Pharaons*, fig. 57; HORNEMANN, *Types*, i, pl. 204; WATERMANN, *Bilder aus dem Lande des Ptah und Imhotep*, Abb. 17; LECA, *Médecine*, fig. 50 [upper]. See *Descr. somm.* No. 6311.

Scribe-statue of deceased, with child (now lost), inscribed, JE 93165. FIRTH, *op. cit.* pl. iv [A], p. 101; ZAYED, *op. cit.* fig. 13 and front cover, pp. 15-17 [i].

Scribe-statue, JE 93166. Id. ib. figs. 12 [right] (*in situ*), 14, 15, pp. 17-18 [ii].

PEḤNŪFER $\text{𓆎} \text{𓆎}$, Director of the Broad Hall, etc. Dyn. VI.

Map LXII.

HASSAN, *Mastabas of Princess Hemet-Rē and Others*, pp. 49-51, with plan, fig. 26, and view, on pl. xxxii. Titles, DE CENIVAL in *Rev. d'Ég.* 27 (1975), p. 67 [E].

False-door. HASSAN, *op. cit.* pls. xxxiii, xxxiv, fig. 27, pp. 50-1.

NIKAУPTAH and SIMERY. Dyn. VI.

Map LXII.

See LAUER in *Ann. Serv.* xxxvii (1937), p. 109 [lower].

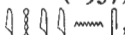
Lintel-fragment of Iḥynes , Carpenter of Nekhen, Dyn. V-VI, probably from a neighbouring tomb. Id. ib. fig. 3, pp. 109 [bottom]-110.

BEBI . Dyn. V.

Map LXII.

HASSAN in *Ann. Serv.* xxxviii (1938), pp. 505-6 [2]; *Archiv aeg. Arch.* 1 (1938), p. 176 [2] = *Chron. d'Ég.* xiii (1938), p. 279 [2] (as Ibi).

ḤETEP , Director of the Broad Hall, Inspector of prophets of Ḥathor of the *mert*-temple, etc. End of Dyn. V or later.

Map LXII.

HASSAN, *Mastabas of Princess Ḥemet-Rc and Others* (hereafter *Mastabas*), pp. 53-8, with plan, fig. 28, and views, on pls. xxxii, xxxv-xxxviii, xli; id. in *Ann. Serv.* xxxviii (1938), pp. 503-5 [1]; *Archiv aeg. Arch.* 1 (1938), pp. 175-6 [1] = *Chron. d'Ég.* xiii (1938), p. 279 [1].

Masons' graffiti, name and titles. HASSAN, *Mastabas*, pl. xl [A, B], p. 56.

Doorway. Fragments of lintel with offering-texts, and drum with name and titles. Id. ib. pl. xxxix [A-C], figs. 29, 30, pp. 54-5; titles from drum, id. in *Ann. Serv.* xxxviii (1938), p. 504 [top].

Burial chamber.

Sarcophagus with palace-façade decoration, and lid with offering-texts. Id. *Mastabas*, pls. xlii-xliv [A], fig. 31, pp. 57-8. Lid, id. in *Ann. Serv.* xxxviii (1938), fig. 72, pp. 504-5; see id. *Giza*, v, p. 62.

RAḲKHUF , Royal chamberlain, Overseer of the Great Court. Dyn. VI.

Map LXII.

HASSAN in *Ann. Serv.* xxxviii (1938), p. 506 [3]; *Archiv aeg. Arch.* 1 (1938), p. 176 [3] = *Chron. d'Ég.* xiii (1938), p. 279 [3].

Serdab. In shaft.

Wooden statues of deceased (Cairo Mus. JE 93164) and female servant carrying chest on her head and driving calf. HASSAN, *Giza*, v, pl. viii, p. 46. Servant, *I.L.N.* June 4, 1938, fig. 5, p. 1001; see BREASTED (Jr.), *Eg. Servant Statues*, p. 61 [6].

E 17. AKHTIḤOTP , Royal chamberlain, Prophet of the Pyramids of Isesi and Unis, Prophet of Ḥeket and of Ḥathor Mistress of Dendera, etc. Late Dyn. VI.

Plan LXV.

MARIETTE, *Mastabas*, pp. 421-30, with plans and view of chapel, pp. 421 [upper], 428; PETRIE (H.) and MURRAY, *Seven Memphite Tomb Chapels*, pp. 7-8 [3], with plan of chapel, pl. xxi [18].

Façade.

(1) False-door.

MARIETTE, op. cit. pp. 422-3. Text in middle column on left outer jamb, BRUGSCH, *Thes.* 235 [D].

(2)-(3) Doorway with titles on jambs and drum, and above, architrave with offering-text.



MARIETTE, op. cit. pp. 426-7, cf. 421 [lower], 429 [bottom]. Architrave, PETRIE (H.) and MURRAY, op. cit. pl. iii [top], pp. 8 [33], 18 [89].

Passage.

(4) and (5) Three registers, men bringing animals and baskets with fowl.

(4) Id. ib. pl. vii [upper], pp. 8 [32], 19 [90, D] (as south wall of offering-room). (5) Id. ib. pl. viii [upper], pp. 8 [32], 20 [92]; part of text in bottom register, MARIETTE, op. cit. p. 430 [top].

Offering-room.

(6)-(7) [1st ed. 4, 5] Upper part above door, deceased in canoe spearing fish and fowling with throw-stick, accompanied by sons Ra'khuf  and Peḥernüfer . Lower part at (6), three registers, men with geese and cranes, bringing oxen, and butchers.

PETRIE (H.) and MURRAY, op. cit. pls. vi [lower], vii [lower], pp. 7-8 [32], 19-20 [91-2]. Some texts, MARIETTE, op. cit. p. 430 [middle].

(8) Two remaining registers of offering-bringers before deceased and son Peḥernüfer.

PETRIE (H.) and MURRAY, op. cit. pl. vi [upper right], p. 19 [90, C].

(9) [1st ed. 7] Upper part, deceased at table, with offering-list and offerings. Lower part, three registers of offering-bringers before deceased and son Ra'khuf.

Id. ib. pl. v, p. 19 [90, B]. Text before deceased, MARIETTE, op. cit. p. 430 [bottom].

(10) [1st ed. 6] False-door.

Id. ib. pp. 424-5; PETRIE (H.) and MURRAY, op. cit. pls. iv, cf. xxi [23-4], pp. 7 [31], 18 [88].

Unplaced.

Remains of two registers of attendants. Id. ib. pl. vi [upper left].

AKHTIḤOTP , Secretary of the Toilet-house, Prophet of Khnum in all his places, Prophet of Ḥeka, etc. Dyn. V or early Dyn. VI.

Map LXII. Plan LXV.

Chapel. In Louvre, E.10958. 'Mastaba du Louvre'.

BÉNÉDITE in *Gazette des Beaux-Arts*, 3 Pér. xxxiii (1905), pp. 177-92; BOREUX, *Guide*, i, pp. 208-27, with plan; VANDIER, *Guide* (1948 and 1952), pp. 6-8, with plan; (1973), pp. 10-11, with plan; DESROCHES-NOBLECOURT, *Le Mastaba au Musée du Louvre (Département des Antiquités Égyptiennes)*, i). View as reconstructed in the museum, BÉNÉDITE, op. cit. fig. on p. 181; BOREUX, *L'Art ég.* pl. i; id. *Guide*, i, pl. xxvii; *Encycl. phot. Louvre*, i, pl. 17 [top].

(1) Doorway. (a)-(b) [1st ed. 1-2] Lintel with offering-text, (c) drum with name and titles, (d) [1st ed. 3] deceased seated receiving list, and registers I-IV, rewarding weavers with jewellery, (e) [1st ed. 4] offerings, two registers of statues dragged before deceased and two sons, including Ra'khuf, Greatest of the physicians of Upper and Lower Egypt, with dancers and two men censuring, and butchers and offering-bringers below.

(a)-(b) Ib. pl. 17 [bottom].

(c) Ib. pl. 17 [middle].

(d) JUNKER, *Giza*, v, Abb. 9, 13 [B, 1] (latter reversed), pp. 46–8; CAPART, *Memphis*, fig. 357. Deceased receiving list, BÉNÉDITE, op. cit. fig. on p. 183; SAINTE FARE GARNOT, *L'Égypte*, fig. on p. 79 [middle]. II–III, BORCHARDT, *Das Grabdenkmal des Königs S'as'herer*, ii, Abb. 9, p. 62.

(e) Upper part of deceased, CAPART, *L'Art ég.* iii, pl. 452. Man censuring statue, PIRENNE, *Hist. civ.* i, pl. 69 facing p. 212; MEKHITARIAN, *L'Égypte*, fig. on p. 90. Name and title of son Rakhuf, VAN DE WALLE and DE MEULENAERE in *Rev. d'Ég.* 25 (1973), pp. 70, cf. 78. Two male dancers and two men holding rope, SMITH, *Hist. Eg. Sculp.* fig. 76 on p. 207; text, MONTET, *Scènes*, p. 367 [3]. Butchers, VANDIER, *Manuel*, v, pl. x [86,3], p. 131 [103].

(2) [1st. ed. 8–9] Registers (I–III partly above doorway), I, men pulling and bringing bundles of papyrus, rope-making, and making papyrus canoe, II, boatmen jousting, and men with birds in canoe, III, man carrying bundle of papyrus, bull mounting cow, calving scene, IV, hippopotamus-hunt, and herdsman with cattle crossing water, V, fowling with clap-net, VI, bringing and netting fish, VII, two sailing-boats.

I–III, and herdsman with cattle in IV, VANDIER, *Manuel*, v, pls. v [46], xxix [197], pp. 65, 448 [6]. Man making rope in I, and man with bundle of papyrus in III, WRZESZ., *Atlas*, iii, Textabb. 41,2 on p. 80, and Taf. 39 [B]. Hippopotamus-hunt in IV, BOREUX, *Études de nautique égyptienne*, fig. 53 [b]; incomplete, PIRENNE, *Hist. civ.* i, pl. 66 [lower] facing p. 201; DRIOTON and DU BOURGUET, *Pharaons*, pl. 16 [lower]; with birds in clap-net in V, *Encycl. phot. Louvre*, i, pl. 24; DU BOURGUET, *L'Art égyptien*, fig. 14. IV–VI (omitting left end), BÉNÉDITE, op. cit. pl. facing p. 190. V (omitting three men on right), VANDIER, *Manuel*, v, pl. xx [157,1], p. 331 [25]. VI, id. ib. pl. xxxiii [242], p. 560 [26]; almost complete, *Encycl. phot. Louvre*, i, pl. 23; right part, PIRENNE, op. cit. pl. 66 [upper] facing p. 201; DESROCHES, *L'Art égyptien au Musée du Louvre* (1941), fig. on 11th p. [bottom]; CAPART, *Memphis*, fig. 377; left part, including cutting out roes, CHARBONNEAUX, *Les Merveilles du Louvre*, i, pl. on p. 39 [lower]; DAUMAS, op. cit. pl. 72; VANDIER in *Kémi*, xvii (1964), fig. 1, pp. 27–9; texts of men cutting out roes, MONTET, *Scènes*, p. 41 [1, and bottom]. VII, BOREUX, *Études de nautique égyptienne*, pl. iii between pp. 410–11; VANDIER, *Manuel*, v, pl. xlili [322–3], pp. 778–9 [60–1]; boat on right (incomplete), *Encycl. phot. Louvre*, i, pls. 21 [lower], 22; CAPART, *L'Art ég.* iii, pl. 453; BYVANCK, *De Kunst*, pl. xxii [80]; POULSEN, *Åg. Kunst. A. und M.* pl. on p. 71; ZANDEE, *De schatten van Egypte*, fig. 44; LARSEN, *En Egyptisk Aeventyrare*, fig. on p. 84; man climbing rigging, and another leaning out of boat, SMITH, *Hist. Eg. Sculp.* figs. 164 [right], 202 [left], pp. 307, 324; boat on left (incomplete), DESROCHES, op. cit. fig. on 11th p. [top]; DAUMAS, op. cit. pl. 75; PIRENNE, op. cit. pls. 74–5 between pp. 220–1; three sailors running, SHURINOVA, *Iskusstvo Drevnego Egipta*, pl. 16; two texts, MONTET, *Scènes*, pp. 352 [2], 353 [3].

(3) [1st ed. 5] Registers before [deceased], I, much effaced, II–III, reaping corn and pulling flax, IV, filling sacks, V, transport of corn with donkeys and piling up sheaves, VI, winnowing and storing grain, and donkeys threshing, VII, rendering accounts, VIII, catching birds in tree, herdsman with goats browsing, etc., IX, two rowing-boats.

II, reaper, man pulling flax, and another drinking, PIRENNE, *Hist. civ.* i, pl. 79 [upper] facing p. 257. Men loading donkey and piling up sheaves in V, and donkeys threshing in VI, *Encycl. phot. Louvre*, i, pls. 25–6; loading donkey and piling up sheaves, *L'Égypte: Art et Civilisation*, Sér. 57 (1951), pl. 11; loading donkey, VANDIER, *Eg. Sculpture*, pls. 12, 13; piling up sheaves, MAZAR, *Views*, i, pl. 95; donkeys threshing, DONADONI, *Arte Egizia*, fig. 50; CHARBONNEAUX, *Les Merveilles du Louvre*, i, pl. on p. 38 [upper]; DESROCHES-NOBLECOURT, *L'Art ég.* fig. 20. Loading donkey in V, and goats browsing in VIII, SHURINOVA, *Iskusstvo Drevnego Egipta*, pls. 18, 19. Donkeys threshing in VI, scribes in VII, and

tree with birds in **VIII**, MICHALOWSKI, *Art*, fig. 17. **VII-VIII**, VANDIER, *Manuel*, v, pls. i [3], xviii [142], pp. 13, 315. **VII**, scribes and man, SAINTE FARE GARNOT, *L'Égypte*, fig. on p. 69; two scribes and man, PIRENNE, *Hist. civ.* i, pl. 71 between pp. 212-13; one scribe, BÉNÉDITE, op. cit. fig. on p. 189; another, RACHET (G. and M. F.), *Dictionnaire de la civilisation égyptienne*, fig. on p. 101. Bringing chiefs in **VII**, and goats browsing in top sub-register of **VIII**, DAUMAS, *Civ. del'Ég.* pls. 70, 73; DESROCHES, *L'Art égyptien au Musée du Louvre* (1941), fig. on 11th p. [middle]; bringing chiefs, CHARBONNEAUX, op. cit. fig. on p. 38 [lower]; MICHALOWSKI, *Art*, fig. 244. Goats browsing, herdsman drinking, and dog waiting for birth of kid, in **VIII**, *Encycl. phot. Louvre*, i, pl. 27; goat browsing and scene with dog, SMITH, *Hist. Eg. Sculp.* fig. 226a, p. 340; goats browsing, MAZAR, *Views*, iv, pl. 108; MICHALOWSKI, *Art*, fig. 248. **IX**, BOREUX, *Études de nautique égyptienne*, pls. i, ii, facing pp. 272, 340; VANDIER, *Manuel*, v, pls. xxxvi [277], xli [306], pp. 691 [39], 777 [6]; boat on right, BÉNÉDITE, op. cit. fig. on p. 177; texts, MONTET, *Scènes*, pp. 328 [middle, 2], 354 [lower, 1], 355 [7].

(4) [1st ed. 6] Offering-list (above aperture of serdab), and below, registers **I-IV**, men with fowl and animals, and bringing various articles.

II-IV, WRESZ., *Atlas*, iii. 88; POULSEN, *Åg. Kunst. A. und M.* pl. on p. 72; VANDIER, *Manuel*, v, pl. ii [16], p. 21. Men with 2nd bull in **II**, and with ibex in **III**, *Encycl. phot. Louvre*, i, pl. 28; man with ibex, BÉNÉDITE, op. cit. fig. on p. 185. First man on right in **III**, SMITH, *Hist. Eg. Sculp.* fig. 173, pp. 311-12.

(5) [1st ed. 7] Deceased seated, and registers, **I-II**, offerings and offering-bringers, **III**, musicians, singers and offering-bringers, **IV**, female clappers and dancers, **V**, offering-bringers and butchers, **VI**, estates.

Upper part of deceased, and **II-VI**, *Encycl. phot. Louvre*, i, pls. 18-21 [upper]. Upper part of deceased, BYVANCK, *De Kunst*, pl. xxii [79]; head, DESROCHES, *L'Art égyptien au Musée du Louvre* (1941), fig. on 9th p. [lower right]; DESROCHES-NOBLECOURT, *Le Mastaba au Musée du Louvre (Département des Antiquités Égyptiennes)*, i, fig. on front cover; BOREUX, *Sculpture*, pl. xv. **II-VI**, DONADONI, *Arte Egizia*, fig. 52. **III-V**, BOREUX, *Guide*, i, pl. xxviii, pp. 224-5; ERMAN, *L'Égypte des pharaons*, pl. xi; BENDOW, *Pyramidetidens Egypt*, pl. facing p. 105 [lower]. Left part of **III-IV**, LAMBRINO, *L'Égypte*, fig. on p. 29 [lower]. **III**, musicians, POSENER, SAUNERON and YOYOTTE, *Dict. civ.* fig. on p. 47; harpist and singer on left, HICKMANN, *45 Siècles*, pl. lxxxix [B]; id. *Instruments de musique (Cat. Caire)*, fig. 71; WRESZ., *Atlas*, iii. 5 [A]; DESROCHES-NOBLECOURT, *L'Art ég.* fig. 22; two singers and flutist, PIRENNE, *Hist. civ.* i, pl. 76 [upper] facing p. 221. Some texts in **III** and **IV**, MONTET, *Scènes*, pp. 361 [3] (inaccurate), 365 [1]. **IV**, clappers and four dancers, WENIG, *Die Frau*, pls. 14-15 [upper], p. 46; clapper and two dancers, VERCOUTTER in GRIMAL, *Histoire mondiale de la femme. Préhistoire et antiquité*, 3rd pl. after p. 112 [lower]; DESROCHES-NOBLECOURT in *Arts Asiatiques*, i (1954), fig. 6, p. 46; clapper and dancer, BOREUX, *Sculpture*, pl. xvii; DESROCHES, *L'Art égyptien au Musée du Louvre* (1941), fig. on 10th p. [lower right]. Clapper and two dancers in **IV**, and 2nd and 3rd offering-bringers in **V**, SHURINOVA, *Iskusstvo Drevnego Egipta*, pls. 17, 15. **V**, 1st to 3rd offering-bringers, CHARBONNEAUX, *Les Merveilles du Louvre*, i, pl. on p. 39 [upper]; 2nd to 4th, PIRENNE, op. cit. pl. 76 [lower] facing p. 221, 2nd and 3rd offering-bringers, and two butchers, VANDIER and SOUGEZ, *La Sculpture égyptienne au Musée du Louvre*, 4th pl.; ABBATE, *Arte egizia*, fig. 24; *Capolavori*, i, No. 10 (1963), figs. on p. 162 [upper, and lower left]; Eng. ed. figs. on p. 154 [upper, and lower left]. Butchers, VANDIER, *Manuel*, v, pl. x [86,2], p. 131 [104]; two, DESROCHES-NOBLECOURT, *Le Mastaba au Musée du Louvre (Département des Antiquités Égyptiennes)*, i, fig. on 3rd p.; LAMBRINO, *L'Égypte*, fig. on p. 24. **V-VI**, SAINTE FARE GARNOT, *L'Égypte*, fig. on p. 101. **VI**, 3rd and 4th estates, DESROCHES, *L'Art égyptien au Musée du Louvre* (1941), fig. on 10th

p. [lower left]; DESROCHES-NOBLECOURT, *Le Mastaba au Musée du Louvre (Département des Antiquités Égyptiennes, i)*, fig. on back cover; BOREUX, *Sculpture*, pl. xvi; 7th estate, BÉNÉDITE, op. cit. fig. on p. 187; names of estates, JACQUET-GORDON, *Domaines*, pp. 347-8 [12S5], cf. figs. 130-1.

(6) False-door.

IKKA , King's *wab*-priest, Chief of the Great Estate, etc. Dyn. V.

Under the Causeway. Exact position unknown.

Wife, Iymert , Prophetess of Hathor Mistress of the Sycamore, etc.

False-door, wood, and offering-basin, in Cairo Mus. JE 72201-2. False-door, SAAD in *Ann. Serv.* xl (1940), pls. lxxiii, lxxiv, pp. 675-80; id. in *I.L.N.* Sept. 28, 1940, fig. 4, p. 412; FORMAN (W. and B.) and VILÍMKOVÁ, *Eg. Art.* pls. 12-14; BINDER-HAGELSTANGE, *Ägypten. Ein Reiseführer* (1966), fig. on p. 382; SOGA, *The Nile*, fig. on p. 144 [left]; *Great Museums*, pl. 34; COTTRELL, *Egypt*, fig. 31. Text of offering-basin, SAAD in *Ann. Serv.* xl (1940), p. 680 [bottom]. Both, see *Descr. somm.* No. 6327; *Chron. d'Ég.* xv (1940), pp. 211-12.

NEFERHERENPTAH , Overseer of hairdressers of the Great House, etc. Dyn. V.

Map LXII. Plan I.XV.

Son, Ptahshepes , Judge and Overseer of scribes.

Texts, ČERNÝ Notebook, 118, pp. 79-82.

(1) Registers (some unfinished), **I**, tending cattle, **II**, two sub-registers of preparing food, with man receiving drink, **III**, mating of cattle, and cow calving, **IV**, milking, **V**, *ka*-servants bringing wine-jars.

Man being beaten in presence of overseer, LAUER, *Saqqara*, pl. 141.

(2) Registers (some unfinished), **I**, men picking figs, and scenes of putting birds into cages and netting them, **II**, men carrying baskets of fruit and picking fruit, and sowing, **III**, men with baskets of fruit, two sub-registers of gardening, ploughing(?), man with two jars, and three men plucking papyrus, **IV**, vintage, including men with resonant sticks, **V**, offering-bringers.

I. Man picking figs and two others kneeling putting pigeons into cages, man standing holding pigeons and others netting them, ALTENMÜLLER in *Antike Welt*, 5 [2] (1974), Abb. 4, 12 on pp. 22-3, 26-7; omitting standing man, LHOPE and HASSIA, *Les Chefs-d'œuvre de la peinture égyptienne*, pls. 61, 60; omitting picking figs and standing man, KEIMER in *Egypt Trav. Mag.* No. 20 (March 1956), figs. 11, 12, p. 28. Picking figs and putting pigeons into cages, FAVRE, *L'Arte*, fig. on p. 155; MÜLLER, *Äg. Kunst*, Abb. 31 [lower]; id. in *Encyclopedia of World Art*, iv, pl. 335 [upper right]; with man bringing birds, id. *Alt-Ägyptische Malerei*, Taf. 6 [b]; SMITH, *Art . . . Anc. Eg.* pl. 49, p. 76. Kneeling man with pigeons in upper sub-register, POSENER, SAUNERON and YOYOTTE, *Dict. civ.* fig. on p. 197 [upper]; VANDERSLEYEN, *Das Alte Ägypten*, Abb. xxii; in lower, with pigeons from netting scene, FORMAN and KISCHKEWITZ, *Die altägyptische Zeichnung*, Abb. 10, 11. Putting pigeons into cages, man bringing birds, and pigeons from netting scene, LAUER, *Saqqara*, pls. 136-7. One pigeon (*cb*), two determinatives of its name, and one of *gnw*-bird, SMITH (W. S.),

Interconnections in the Ancient Near East, fig. 183 [a]. Pigeons from netting scene, DE RACHEWILTZ, *L'Arte*, Tav. 55, p. 72. Man kneeling and another standing with birds in front of tree, SMITH, *Art . . . Anc. Eg.* pl. 50 [A], p. 76; ALDRED in PIGGOTT, *The Dawn of Civilization*, pl. on p. 120 [56].

II. Two men with baskets, and others picking fruit, LAURENT-TÄCKHOLM, *Faraos blomster*, pl. on pp. 164-5 [upper]. Middle parts of two men, PILLET in *Ann. Serv.* lii (1954), fig. 11 (by Épron), p. 100.

III. Man carrying, and two others squatting, with baskets of fruit, receiving a vegetable from man standing, with man kneeling in gardening scene, ALTENMÜLLER, *op. cit.* Abb. 13 on p. 28. Man carrying and another squatting with baskets of fruit, LAURENT-TÄCKHOLM, *op. cit.* pl. on p. 166; DESROCHES-NOBLECOURT and DU BOURGUET, *L'Art égyptien*, pl. xi. Squatting man receiving a vegetable from man standing, and another kneeling, LAUER, *Saqqara*, pl. 138. Man with two jars and others plucking papyrus, ALTENMÜLLER, *op. cit.* Abb. 1 on p. 20.

IV. Four men picking and five men treading grapes, LAUER, *Saqqara*, pls. 139-40. Three men picking grapes, ALDRED, *op. cit.* pl. on p. 121 [57]; another two, DE RACHEWILTZ, *L'Arte*, Tav. 44, p. 55. Men with resonant sticks, HICKMANN in *Bull. Inst. Ég.* xxxvi (1953-4), fig. 2, p. 587 = *id. Musicologie pharaonique*, fig. 2, p. 16.

(3) Unfinished and uninscribed false-door.

NI^cANKHRĒ^c , Royal acquaintance of the Great House, Secretary of NeferirkarĒ^c. Dyn. V.

Map LXII.

Inscribed doorway. No decoration inside.

AKHTIḤOTP , Director of *warb*-priests of Sekhmet of the Great House, Prophet of Buto, etc. Dyn. V-VI.

Map LXII.

ZAYED in *Ann. Serv.* lv (1958), pp. 127-37, with position on pl. i, and view, pl. vi. View, BRUNTON in *I.L.N.* Feb. 26, 1944, fig. on p. 248 [top]. Plan and sections, BADAWI in *Ann. Serv.* xl (1940), Taf. xlvii, p. 495. See *Chron. d'Ég.* xx (1945), p. 80 (as Ptah-Hetep).

Chapel.



Drum with title.

False-door, with inscribed offering-table. ZAYED, *op. cit.* pls. ii-v, pp. 128-36, cf. 136-7.

Wooden niche-stela of Nezi , Gold-worker, Dyn. IV-V(?). BADAWI in *Ann. Serv.* xl (1940), Taf. xlvi, Abb. 63, pp. 495-501; BRUNTON, *op. cit.* fig. on p. 248 [middle].

Serdab. View *in situ*, LAUER, *Saqqara*, pl. 135.

Wooden statues with remains of texts, seven in Cairo Mus. JE 93168-74. Six of deceased and one of wife, BRUNTON, *op. cit.* fig. on p. 248 [bottom]; five of deceased and one of wife, ZAYED, *op. cit.* pls. ix-xvii, cf. vii, viii (*in situ*), p. 136; BATRAWI in *Ann. Serv.* xlvi (1948), pls. ii, cf. iii (*in situ*), pp. 492-4; one of deceased (= No. 4 of BATRAWI), *Gazette des Beaux-Arts*, lxxxvii (1976), Supp. March 1976, fig. 111; upper part, SMITH (J. L.), *Tombs, Temples, and Ancient Art*, pl. facing p. 224 (painting).

IRUKAPTAH  KHENU , Master butcher of the Great House, King's *warb*-priest, etc. Early Dyn. V (Altenmüller) or Dyn. VI.

Map LXII. Plan LXV.

DE RACHEWILTZ, *The Rock Tomb of Irw-k3-Pth*, with position, on pl. i, and views of exterior, pls. ii, iii; FISCHER in *J.A.O.S.* 82 (1962), pp. 75-6; *Chron. d'Ég.* xx (1945), p. 80 (as Akhet-Hetep). Dating, ALTENMÜLLER in *Égyptologie*, 1 (*Actes du XXIX^e Congrès international des Orientalistes*), pp. 1-5.

Offering-room.

Plan, DE RACHEWILTZ, fig. 1. Views, id. ib. frontispiece and pls. iv-vi; ELISOFON, *The Nile*, pl. 251; BRUNTON in *I.L.N.* Feb. 26, 1944, fig. on p. 249 [lower].

(1) Two registers of men making bed and bringing chest, and below, (a), (b), two rock-cut statues in niches.

DE RACHEWILTZ, pls. xxi, xxii, pp. 20-2.

(2)-(3) Upper part, deceased at table, with offerings and men with cuts of meat before him, and four groups of butchers. Lower part, four registers of butchers and offering-bringers at left end, and (c)-(j), eight rock-cut statues in niches (j unfinished), with offering-text above and names and titles on jambs.

Id. ib. pls. viii-xii [1], xvii [2]-xx, pp. 7-8, 9-13 [top], 17-20, cf. fig. 2 [B, a-d, 1-8]. 1st group of butchers, MEKHITARIAN, *Egyptian Painting*, pl. on p. 10; with statue below, MÜLLER (H. W.) in *Encyclopedia of World Art*, iv, pl. 337. 2nd, and two butchers from 1st group, with statues below, ELISOFON, *The Nile*, pl. 250; 1st and 2nd and two butchers from 3rd group, with statues below, DE RACHEWILTZ, *L'Arte*, Tav. 42, p. 54. Statues, (e)-(h) DRIOTON and DU BOURGUET, *Pharaons*, pl. 32; (e)-(j) ALDRED, *Egypt*, fig. 100; (f)-(i) MURRAY, *Splendour*, pl. xlix [3].

(4) Deceased in canoe fowling with throw-stick, accompanied by family, man spearing in smaller boat on left, and registers below, men in canoes with cattle crossing canal, netting fowl and fish(?).

DE RACHEWILTZ, pl. xvi, xvii [1, left], pp. 16-17, cf. fig. 2 [F].

(5)-(6) Upper part, two registers of offerings. Lower part at (5), four registers of boats, and at (6), preliminary sketches for rock-cut statues.

Id. ib. pls. vii, xiii-xv, xvii [1, right], pp. 8, 13-15, cf. fig. 2 [A, C, E].



(7) Above niche, remains of deceased seated. Id. ib. pl. xii [2], p. 13.

(8) False-door. Id. ib. pl. xxiii, pp. 22-6 with figs. 3, 4.



(9) Rock-cut statues in niches, three male and one female. Id. ib. pls. xxiv, xxv, pp. 27-8.

Finds

Unfinished seated statue. Id. ib. pl. xxviii [2], p. 29.



NÜFER , Inspector of the *wa'bt*, Director of singers, etc., and his father KAḤA , Director of singers, Prophet of Mert of Upper Egypt, etc. Middle to late Dyn. V.

Map LXII. Plan LXV.

Wife of Nüfer, Khons , Royal acquaintance. Wife of Kaḥa and mother of Nüfer, Mertiotēs , Prophetess of Ḥathor Mistress of the Sycamore in all her beautiful places, and of Neith North of the Wall, etc.

MOUSSA and ALTENMÜLLER, *The Tomb of Nefer and Ka-hay* (hereafter MOUSSA), passim, with plan, fig. 2, and position, on fig. 1 (review, with corrections, etc., FISCHER in *Bibliotheca Orientalis*, xxxi (1974), pp. 66–9); LECLANT in *Orientalia*, n.s. 36 (1967), pp. 190 [lower]–191.

Offering-room. View, LAUER, *Saqqara*, pl. 144.

(1)–(2) At either end, deceased, with daughter and dog on left, and wife and daughter on right, and registers between, **I**, man with papyrus roll, herdsman skinning goat hung from tree, others with goats grazing on trees, papyrus thicket with birds hovering, papyrus harvest, making canoe, and herdsmen rendering accounts, left end of **II–III**, netting fish, and right of it, in **II**, herdsman with cattle crossing canal, tending and bringing cattle, and in **III**, cooking, bringing and netting fowl. Two registers below, with Thenti  , 'Brother of the endowment', etc., on left, and two sailing-boats on right, and between them, **IV**, wine press (with baboon working with men), men with resonant sticks and others treading grapes, two pairs of dwarfs as jewellers, men carrying lotus flowers, female clappers and dancers, and woman with small girl seated in kiosk, **V**, ploughing, sowing with sheep treading in grain, and boatmen jousting.



MOUSSA, pls. 1–17, pp. 19–26 [E.A.], cf. fig. 3. Papyrus harvest in **I**, herdsman with cattle crossing canal in **II**, and boat on right, ALTENMÜLLER in *Antike Welt*, 5 [2] (1974), Abb. 6, 19, on pp. 24, 33; VANDERSLEYEN, *Das Alte Ägypten*, Abb. xx, 247. Left part of **III–V**, and middle of **II–IV**, LAUER, *Saqqara*, pls. 145–6. Middle parts of **IV** and **V**, TOUNY and WENIG, *Sport*, Taf. 47. Wine press in **IV**, DARBY, GHALIOUNGUI and GRIVETTI, *Food: The Gift of Osiris*, ii, fig. 14.6.

(3) Registers, **I**, goats grazing on trees, **II**, an overseer, with man holding sunshade, and boat-building scene (including a baboon and monkey), **III**, men dressing logs, and others felling trees, **IV**, carpenters sawing, making coffin, bed, door-bolt, and wooden column, **V**, men with cattle and fowl.

MOUSSA, pls. 18–23, pp. 27–8 [E.B.], cf. fig. 3. Goats grazing in **I** and boat-building in **II**, ALTENMÜLLER, op. cit. Abb. 18 on p. 32.

(4) Nüfer seated receiving list, with wife squatting, and registers, **I**, two scribes and dwarf holding palette, **II–III**, geese, and below, **IV–V**, men bringing cattle and wild animals, **V**, butchers, **VI**, offering-bringers.

MOUSSA, pls. 24, 25 [a], pp. 28–9 [S.A.], cf. fig. 4.

(5) Upper part (above apertures of serdab), Nüfer at table, with two priests and offering-list (all painted only). Lower part, Nüfer leaning on staff, and wife squatting, with offerings, offering-bringers, musicians, singers, and maid-servant washing her hands before them, and brothers of deceased Seniofef, Ikhi   and Werbau behind them.

Id. ib. pls. 25 [b], 26–7, pp. 29–32 [S.B.], cf. fig. 4.

(6) False-door of Nüfer, with offerings, offering-bringers and brothers before deceased at table above it, and deceased and wife right of it.



Id. ib. pls. 28 [left], 29, 30, pp. 32–4 [W.A. 1–10], cf. figs. 5, 6; VANDERSLEYEN, *Das Alte Ägypten*, Abb. 43 [left], 246. Deceased and wife, ALTENMÜLLER, op. cit. Abb. 17 on p. 31.

(7) Palace-façade false-door of Khenu   , Director of singers in the Two Houses (son of Nüfer).



MOUSSA, pls. 28 [left middle], 31, pp. 34–5 [W.A. 11], cf. figs. 5, 6; VANDERSLEYEN, op. cit. Abb. 43 [left middle].

(8) and (9) False-doors of Kaḥa and wife, and above, both seated at tables, with offering-bringers and children. Between false-doors, Kaḥa and wife.

MOUSSA, frontispiece, pls. 28 [right middle], 32-5, pp. 35-7 [W.B.], cf. figs. 5, 7; VANDERSLEYEN, op. cit. Abb. 43 [right middle]. Children, ALTENMÜLLER, op. cit. Abb. 5 on p. 24.

(10) False-door of Werbau , Inspector of singers, etc. (brother of Nüfer), and his wife Khentkaus , with both of them at table and family above it, and standing with small son right of it.

MOUSSA, pls. 28 [right], 36-8, pp. 37-9 [W.C.], cf. figs. 5, 8; VANDERSLEYEN, op. cit. Abb. 43 [right].

(11) False-door of Seniotef , Inspector of singers, etc. (brother of Nüfer), and his wife Khnemt , with both of them at table above.

MOUSSA, pl. 39, pp. 39-42 [W.D.], cf. figs. 5, 9.

(12) (painted only) [Deceased] and wife followed by two registers of children.

Id. ib. fig. 10, p. 42.

Finds

Wooden box, with cursive text of linen account of year of 6th census, mentioning Wāt , on inside lid, found in Shaft 8. Text, id. ib. fig. 11 (by Posener-Kriéger), pp. 43-5.

Offering-basin of Kaḥa and wife. Id. ib. pl. 42 [a], fig. 12, p. 45 [a].

Wooden model boat. Id. ib. pl. 41 [a], p. 45 [b].

ANKHIRPTAḤ , Overseer of beef fat, etc. Dyn. V.

Map LXII.



Wife, Nebt , Prophetess of Ḥaṭḥor, etc.

Lintel of doorway, with offering-text and deceased and wife seated. Text, MOUSSA and ALTENMÜLLER, *The Tomb of Nefer and Ka-hay*, p. 10 [a-c].



KAIANKH , Butcher of the Great House, etc. Dyn. V.

Map LXII.

Drum of doorway with name and titles. Text, id. ib. p. 10 [d].

NIANKH-KHNUM  and KHNEMḤOTP , both Prophets of Rē in the Sun-temple of Neuserrē, Overseers of manicurists of the Great House, etc. Probably temp. Neuserrē or Menkauḥor.

Map LXII. Plan LXVI.

Wife of Niankh-khnum, Khentkaus , Prophetess of Ḥaṭḥor Mistress of the Sycamore, etc.; of Khnemḥotp, Khenut , same title.

MOUSSA and ALTENMÜLLER, *Das Grab des Nianchchnum und Chnumhotep*, passim, with plans and section, Abb. 1, 2, and views, Taf. 1. See LAUER in *Bull. Soc. fr. d'Ég.* No. 43 (July 1965), p. 20; LECLANT in *Orientalia*, n.s. 35 (1966), pp. 138-9 [18, d]; n.s. 36 (1967), p. 190 [upper]. View, VANDERSLEYEN, *Das Alte Ägypten*, Abb. 45; RUFFLE, *Heritage of the Pharaohs*, fig. 27. Some scenes, ELLIS in *Egypt Trav. Mag.* No. 136 (Feb. 1966), figs. on pp. 27-8; BAKRY in ib. Nos. 139/140 (May-June 1966), figs. on pp. 12-14.

I. Forecourt.

(1) (a)-(b) Architrave, and (c), (d), pillars, all with names and titles.

MOUSSA and ALTENMÜLLER, Taf. 2, Abb. 3, p. 46 [2].

(2) and (3) Four registers of funeral scenes of Khnemḥotp at (2), and of Ni'ankh-khnum at (3). **I**, offerings, and men offering and censng before statue, **II**, shrine with statue dragged by oxen and men, with representations of false-doors above, **III**, two buildings with boat carrying shrine with statue between them, with butchers above, **IV**, boat with shrine with statue towed by two rowing-boats and men.

(2) Id. ib. Taf. 6, 8-11, pp. 46-51 [3.1]. (3) Id. ib. Taf. 7, 12-15, pp. 51-5 [3.2].

(4) Double-scene, left, Khnemḥotp at table, right, Ni'ankh-khnum at table, with offerings and butchers between them, and lintel with offering-text below. On either side of doorway, (a) Khnemḥotp spearing fish, (b) Ni'ankh-khnum fowling with throw-stick, both accompanied by families.

Id. ib. Taf. 3-5, Abb. 4-6, pp. 55-61 [3.3].

II. Vestibule.

(5) Doorway. (a) Drum with titles of Ni'ankh-khnum and Khnemḥotp, (b) offerings, and four registers below, dragging statues and chests with feathers on top, and overthrowing bull, (c) offerings, and four registers below, dragging statues, and overthrowing bull.

Id. ib. Taf. 16-19, Abb. 7, pp. 61-6 [3.4].

(6) Six registers of baking and brewing.

Id. ib. Taf. 23, pp. 66-72 [4.1].

(7) At top, Ni'ankh-khnum with small son on left, and Khnemḥotp with small son on right, with four registers between them, **I**, men felling tree, and herdsmen with goats, **II**, boat-building, **III** and **IV**, vintage and gardening scenes. On either side of doorway, (a) scenes of men catching birds, and sailing-boat, (b) barbers, scenes of manicure and pedicure, market-scenes, and two sailing-boats.

Id. ib. Taf. 20-2, 24-7, Abb. 8-10, pp. 72-86 [4.2]. Fishmonger in **II**, and woman selling drink in **III**, ALTENMÜLLER in *Antike Welt*, 5 [2] (1974), Abb. 10, 11, on p. 25.

(8) Ni'ankh-khnum and Khnemḥotp seated, with text of contract with funerary priests before them, and offering-bringers, relatives, officials, and two boats below.

MOUSSA and ALTENMÜLLER, Taf. 28-30, Abb. 11, pp. 86-92 [4.3].

(9) At top, Khnemḥotp with small son on left, and Ni'ankh-khnum with small son on right, with five registers between them, netting fowl and fishing, including netting, fishing with baskets, and with clap-net. Below, Ni'ankh-khnum and Khnemḥotp with small sons on left, and four registers, men with fruit, wine-cellar, bringing animals, and offering-bringers in boats. Lintel above doorway, ox and antelope.

Id. ib. Taf. 31-7, Abb. 12, 13, pp. 92-105 [4.4]. Some men netting fish in **III**, ALTENMÜLLER, op. cit. Abb. 8 on p. 24.

(10) (partly above doorway) Registers, **I-II**, boats and names of oils below, **III-V**, hunting scenes, **VI-X**, picking grapes and fruit, and vintage scenes.

MOUSSA and ALTENMÜLLER, Taf. 38-41, Abb. 14-16, pp. 105-13 [4.5]. Man with dogs in **V**, ALTENMÜLLER, op. cit. Abb. 9 on p. 25.

III. Court.

(11) Doorway. Thicknesses, Ni'ankh-khnum at (a), and Khnemḥotp at (b), in palanquin on donkeys, with estates below.

MOUSSA and ALTENMÜLLER, Taf. 42-3, pp. 113-15 [5.1].

IV. Vestibule.

(12) Names and titles, of Khnemḥotp at (a), and Ni'ankh-khnum at (b), with deceased below.

Id. ib. on Taf. 44-5, pp. 115-16 [6.1].

(13) Lintel, double-scene, Ni'ankh-khnum on left, and Khnemhotp on right, with men bringing cattle before them.

Id. ib. Taf. 49, Abb. 17, pp. 116-17 [6.2].

(14) and (15) Khnemhotp with wife at (14), and Ni'ankh-khnum with wife at (15), with registers of wild animals before them, and men bringing animals below.

Id. ib. Taf. 46-8, Abb. 18, 19, pp. 117-20 [6.3, 4].

V. Outer Hall.

(16) At top, Khnemhotp on left, and Ni'ankh-khnum on right, both at table, with offerings and offering-bringers before them. Below, doorway, (a)-(b) lintel with offering-text, and drum with names, (a) Khnemhotp with small son, (b) Ni'ankh-khnum with small son, thicknesses, (c) and (d) **I-III**, offering-bringers, **IV**, men bringing cattle.

Id. ib. Taf. 50-3, Abb. 20-3, pp. 120-6 [6.5, 6].

(17) Four registers, **I**, scene of rendering accounts, **II**, filling granaries, **III**, measuring corn, **IV**, sifting and winnowing.

Id. ib. Taf. 54, Abb. 24, pp. 126-8 [7.1].

(18) On left, Khnemhotp under sunshade, with small son, on right, Ni'ankh-khnum carried in palanquin, with four registers between and below, agriculture, including flax-harvest.

Id. ib. Taf. 55-60, pp. 128-33 [7.2, Sz. 29].

(19) On left, Khnemhotp seated, with small son, on right, Ni'ankh-khnum with small son, and between, registers, **I**, sculptors, **II**, metal-workers, **III**, carpenters and jewellers, and below whole scene, **IV**, estates.



Id. ib. Taf. 61-7, pp. 133-42 [7.2, Sz. 30]. Man painting statue in **I**, ALTENMÜLLER in *Antike Welt*, 5 [2] (1974), Abb. 20 on p. 34. Part of **I** and **II**, VANDERSLEYEN, *Das Alte Ägypten*, Abb. 250, and fig. 69 on p. 288.

(20) Ni'ankh-khnum on left, and Khnemhotp on right, both at table, with offerings between them, and two registers of musicians, singers, clappers, and dancers below.

MOUSSA and ALTENMÜLLER, Taf. 68-70, Abb. 25, pp. 142-7 [7.3].

(21) At top, (a)-(b) lists of oils. Below, (a) three registers with offering-bringer in each, (c) Ni'ankh-khnum and Khnemhotp embracing, with two registers of children on either side, and an unfinished false-door at bottom.

Id. ib. Taf. 71-3, pp. 148-50 [7.4, Sz. 32]. (c) LAUER, *Saqqara*, pl. 142; VANDERSLEYEN, op. cit. Abb. 248; upper part of Ni'ankh-khnum and Khnemhotp, ALTENMÜLLER, op. cit. Abb. 3 on p. 21.

(21 bis) Upper part, Ni'ankh-khnum fowling with throw-stick, and Khnemhotp spearing fish, both accompanied by families, and right of it, registers, **I**, herdsmen cooking and making mats, **II**, tending cattle, **III**, cattle crossing canal, with herdsmen in boats, and under whole scene, **IV**, boatmen jousting, with herdsmen in boat on right. Lower part, five false-doors, from left, (a) Ni'ankh-khnum, (b) Khnemhotp, (c) Ḥemrē , Prophet of Rē in the Sun-temple of Neuserre, etc. (son of Ni'ankh-khnum), with offering-table in front of it, (d) Theset , Prophetess of Neith and Ḥathor, etc. (wife of Ḥemrē), with offering-table in front of it, (e) unfinished.

MOUSSA and ALTENMÜLLER, Taf. 74-81, pp. 150-60 [7.4, Sz. 33]. Upper part, fowling and fishing, with part of **IV** below, VANDERSLEYEN, op. cit. Abb. 251; **I-III**, and part of **IV** below, LAUER, op. cit. pl. 143.

VI. Inner Hall.

(22) and (23) Doorways. (a) and (b) Registers, **I-III**, men bringing animals, **IV**, birds.

MOUSSA and ALTENMÜLLER, Taf. 82-5, pp. 160-3 [7.5]. (23) (a) **I-II**, ALTENMÜLLER in *Antike Welt*, 5 [2] (1974), Abb. 15 on p. 29.

(24) Khnemhotp and Ni'ankh-khnum embracing.

MOUSSA and ALTENMÜLLER, Taf. 91, p. 163 [8.1].

(25) and (26) Ni'ankh-khnum at (25), and Khnemhotp at (26), both at table, with offering-list above, and offerings, offering-bringers, and butchers before them.

Id. ib. Taf. 86-9, pp. 163-71 [8.2, 3].

(27)-(29) False-door of Ni'ankh-khnum (much damaged), Ni'ankh-khnum and Khnemhotp embracing, and false-door of Khnemhotp.

Id. ib. Taf. 90, 92, Abb. 26, pp. 171-3 [8.4].

Finds

Drum with names and titles of Ni'ankh-khnum and Khnemhotp, re-used. Text, id. ib. p. 173 [9.1].

Drum of Mereru , One belonging to the endowment of Ni'ankh-khnum and Khnemhotp. Text, id. ib. p. 173 [9.2].

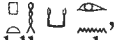
IRENKAPTAḤ , Master butcher of the Great House, Overseer of beef fat, etc. Middle to late Dyn. V.

Map LXII. Plan LXVI.

Wife, Khenut , Prophetess of Hathor.

MOUSSA and JUNGE, *Two Tombs of Craftsmen*, pp. 31-46, with plan and section on fig. 1.

Offering-table of deceased (name as ). Id. ib. illustr. 4, p. 46, cf. fig. 11.

Offering-room. Painted decoration.

(1) Three registers of sailing-boats and rowing-boats.

Id. ib. pl. 8, pp. 36-7 [1, A].

(2) On right, deceased and wife, with registers, **I**, ploughing, **II**, flax and corn harvest, **III**, donkeys transporting produce, **IV**, scribes, piling sheaves, men driving donkeys, **V** (under whole scene), donkeys and sheep threshing, and people winnowing.

Id. ib. pls. 9, 10, pp. 37-40 [B, C].

(3) [Papyrus-harvest, making canoes], bringing, and cutting open fish.

Id. ib. pl. 11, pp. 40-1 [2, A].

(4) Deceased spearing fish, and fowling with throw-stick, with men netting fish below.

Id. ib. pl. 12, pp. 41-2 [C]. Spearing fish, *J.L.N.* Jan. 8, 1966, fig. on p. 16 [upper left]; ALTENMÜLLER in *Antike Welt*, 5 [2] (1974), Abb. 16 on p. 30.

(5) Six registers, including netting fowl, carrying bundles of papyrus and making canoes, tending cattle, baking, and mat-making.



MOUSSA and JUNGE, pl. 13, p. 41 [B].

(6) False-door.

Id. ib. illustr. 3, frontispiece [upper right], pp. 43-4 [A], cf. fig. 10.

(7) [Deceased and wife], with offering-list, offerings, musicians and singers, and offering-bringers.

Id. ib. pl. 14, pp. 44-5 [B].

NEFERSEHEMPTAH  , Overseer of metal-workers, and SEKHENTIU  , Overseer of gold-workers. Late Dyn. V.

Map LXII. Plan LXXVI.

MOUSSA and JUNGE, *Two Tombs of Craftsmen*, pp. 13-27, with plan and section on fig. 1. Names and title on lintels in shafts, id. ib. p. 15.

Offering-room. Painted decoration.

(1) Three registers, furniture and beds with canopies, including servants making bed in bottom register.

Id. ib. pls. 1, 2, frontispiece [upper left], pp. 19-20 [1].

(2) Sekhentiu (probably), wife, and son, with dedicatory text above, four registers of attendants behind, and five registers before them, **I**, sowing, ploughing, men driving [animals treading seed], **II**, flax and corn harvest, **III**, piling up sheaves, donkeys transporting produce, **IV**, winnowing, **V**, scribes and rendering accounts.

Id. ib. pls. 3-5, frontispiece [lower left and right], pp. 20-2 [2, A-C]. Left half of registers, VANDERSLEYEN, *Das Alte Ägypten*, Abb. xxi. Ploughing in **I**, ALTENMÜLLER in *Antike Welt*, 5 [2] (1974), Abb. 7 on p. 24.

(3) (much destroyed) Spearing fish and fowling with throw-stick.

MOUSSA and JUNGE, pl. 6, pp. 22-3 [D-E], 24-6 [H].

(4) (much destroyed) Man and wife at table, and offerings.

Id. ib. pl. 7, p. 23 [F, G].

(5)-(7) False-doors, (5) unfinished and uninscribed, (6) Sekhentiu, (7) Neferseshemtah.

Id. ib. illustr. 1, 2, pp. 26-7 [3], cf. figs. 3, 4. Upper part of (7), *I.L.N.* Jan. 8, 1966, fig. on p. 16 [upper right].

NAME UNKNOWN. Late Dyn. V.

Map LXII.

Plan, MOUSSA and JUNGE, *Two Tombs of Craftsmen*, on fig. 1.

Lintel with remains of offering-text. Text, id. ib. p. 13.

PTAHSHEPSES  , King's son, Hereditary prince. End of Dyn. V.

In the Valley Temple.

See *Chron. d'Ég.* xx (1945), pp. 82-3.

Sarcophagus, uninscribed, schist, found on pavement of terrace, in Cairo Mus. JE 87077. BRUNTON in *Ann. Serv.* xlvii (1947), pl. xv, pp. 125, 132-3; id. in *I.L.N.* Feb. 26, 1944, fig. on p. 247 [middle]; DRIOTON in *Bull. Inst. Ég.* xxvi (1943-4), fig. 3, pp. 81-3; DONADONI ROVERI, *Sarcofagi egizi*, Tav. xx [1], xxii [1], fig. 13 [a], p. 130 [B 52].

Gold belt with inlaid inscribed plaque, found on mummy, in Cairo Mus. JE 87078. DRIOTON, op. cit. figs. 5-7, pp. 84-9; BRUNTON in *I.L.N.* Feb. 26, 1944, fig. on p. 247 [bottom]; MOUSTAFA in *Ann. Serv.* liv (1957), pls. i-viii, pp. 149-51; VILÍMKOVÁ, *Chefs-d'œuvre*, pls. 7, 8; WILKINSON (A.), *Ancient Egyptian Jewellery*, fig. 31, p. x; MÜLLER (H. W.) in *Encyclopedia of World Art*, iv, pl. 343 [upper]; VANDERSLEYEN, *Das Alte Ägypten*, Abb. liv [a].

METHETHI , Noble of the King, Overseer of the department of tenants of the Great House, etc. Temp. Teti.

Probably from here.

Wife, Inti .



KAPLONY, *Studien zum Grab des Methethi* (hereafter *Studien*). Objects in various museums, see id. in *Orientalia*, N.S. 37 (1968), pp. 2-3 [§ 2].

Façade.

Left, deceased and small son Ptaḥsabu , and remains of conventional autobiographical text, formerly in Mallon Collection, now in Toronto Mus. 953.116.1. Id. *Studien*, fig. on p. 32, cf. pp. 31-6; STEINDORFF in *Studi Rosellini*, ii, Tav. xxxiii, pp. 263-7; NEEDLER in *Bulletin of the Royal Ontario Museum of Archaeology*, No. 22 (Sept. 1954), pp. 5-13 with fig. 3; id. in *The Connoisseur*, clxvi (1967), fig. 8 on p. 98; *The Art Quarterly*, xvii (1954), pl. on p. 65 [top, 2], cf. p. 63; HEINRICH, *Art Treasures in the Royal Ontario Museum* (1963), pl. on p. 13.

Right, deceased and small son Iḥy , and address and wisdom text, formerly in Kofler-Truniger Collection, now in Berlin (West) Mus. 5/70. KAPLONY, *Studien*, fig. on p. 33, cf. pp. 36-44; id. in *Orientalia*, N.S. 37 (1968), pls. i-iii, pp. 1-2, 3-62; GARDINER MSS. photo. 28.492 (taken before broken up). See *Berliner Museen*, N.F. xxi (1971), p. 57.

Doorway.

Thicknesses, left, deceased with small figures of son Khuensobk  and daughter Irt-sobk , and text of rewarding craftsmen, right, with sons [Ptaḥ]ḥotp and Iḥy, and conventional autobiographical text, in Kansas City, William Rockhill Nelson Gallery of Art, 52-7.2, 1. KAPLONY, *Studien*, figs. on pp. 28-9, cf. pp. 26-31; GOEDICKE in *Ä.Z.* 83 (1958), Taf. i, pp. 18-27, cf. EDEL in ib. pp. 11-17 [ix] with Abb. 2; *The Art Quarterly*, xvii (1954), pl. on p. 65 [top, 3 and 1], cf. p. 63; *Handbook of the Collections* (1959), figs. on pp. 14, 15 [right, left].

Lintel, deceased with son Ptaḥḥotp, in Louvre, E.25681. KAPLONY, *Studien*, fig. on p. 25. See VANDIER in *La Revue du Louvre*, 16 (1966), pp. 240 with note 35, 243; *Vingt ans*, p. 20 [Cat. 73]; COONEY in *Brooklyn Mus. Bull.* xv [1] (Fall 1953), p. 19.

False-door.

In New York, M.M.A. 64.100. KAPLONY, *Studien*, fig. on p. 51, cf. pp. 48-52; *Gazette des Beaux-Arts*, lxxix (1967), Supp. Feb. 1967, fig. 205; text on right jambs, COONEY, op. cit. fig. 14, p. 19.

Blocks.

Deceased in canoe fowling with throw-stick, accompanied by wife, son Ptaḥḥotp and daughter Irt-sobk, in Riggisberg, Abegg-Stiftung, 12.39.67. KAPLONY, *Studien*, figs. on pp. 10, 12, cf. pp. 9-20; id. in *Orientalia*, N.S. 39 (1970), pl. xiv, pp. 264-8. STETTLER and OTAVSKY, *Abegg-Stiftung Bern in Riggisberg*, i, *Minor Arts—Sculpture—Painting*, pl. 11.

Painted fragments, in Louvre, E.25507-49. Men with oryxes, VANDIER, op. cit. fig. 1, p. 235; id. *Manuel*, v, pl. ii [9], p. 17. Netting and bringing birds, female harpists, butchers, cow calving and milking scene, and herdsmen in canoe crossing canal, id. ib. pls. v [47], xix [153], pp. 70, 349. Offerings and priests, id. in *La Revue du Louvre*, 16 (1966), fig. 2, p. 235; *Gazette des Beaux-Arts*, lxxix (1967), Supp. Feb. 1967, fig. 1. See KAPLONY, *Studien*, pp. 71-4; VANDIER, *Guide* (1973), p. 13.

Probably from this tomb.

Three adjoining blocks¹ with nine offering-bringers, in Hanover Mus. 1957.78. Three offering-bringers, WOLDERING, *Ausgewählte Werke der ägyptischen Sammlung* (1958), pl. 20. See id. *Kestner-Museum 1889-1964*, p. 42 [12].

Five donkeys in harvest scene, in Toronto Mus. 953.116.2. KAPLONY, *Studien*, fig. on p. 23, cf. pp. 22-4; NEEDLER in *Bulletin of the Royal Ontario Museum of Archaeology*, No. 22 (Sept. 1954), pp. 13-14 with fig. 4; *Archaeology*, 8 (1955), fig. on p. 79 [middle].

Deceased in palanquin, with three men handing in list, and man with collar from rewarding scene, in Richmond (Virginia) Mus. 55.6.2. KAPLONY, *Studien*, fig. on p. 22, cf. pp. 21-2; id. in *Orientalia*, n.s. 37 (1968), pl. lxi, pp. 339-41; BOTHMER in *Arts in Virginia*, iii [1] (Fall 1962), on fig. 3 on p. 25; REED in ib. ix [2] (Winter 1969), fig. 5 on p. 10; *Ancient Art in the Virginia Museum* (1973), fig. on p. 20 [11]. See *The Art Quarterly*, xviii (1955), p. 301.

Statues of deceased. All wooden.

In short kilt, in Boston Mus. 47.1455. KAPLONY, *Studien*, figs. on pp. 56-9, cf. pp. 55-6; COONEY in *Brooklyn Mus. Bull.* xv [1] (Fall 1953), fig. 8, pp. 1, 19; BOTHMER in *Boston Mus. Bull.* xlvi (1948), figs. 1-7, pp. 30-6; ALDRED, *O.K. Art*, pl. 59; WHITEHILL, *Museum of Fine Arts Boston. A Centennial History*, i, figs. on p. 280. Upper part, SMITH, *Anc. Eg.* (1952), fig. 34; (1960), fig. 31; *Illustrated Handbook* (1964), fig. on p. 183 [upper right]; (1976), fig. on p. 161 [upper right].

In short kilt and wearing necklace, in Brooklyn Mus. 53.222. KAPLONY, *Studien*, fig. on p. 66, cf. pp. 64-8; *The Brooklyn Museum. Five Years of Collecting Egyptian Art, 1951-1956*, pls. 1-3, pp. 1-2 [1A]; KAYSER, *Ägyptisches Kunsthandwerk*, Abb. 209; WARD, *The Spirit of Ancient Egypt*, pl. iv. Upper part, DAVID, *The Egyptian Kingdoms*, fig. on p. 103 [lower left]. Text, JAMES, *Corpus*, i, pl. xxiii [56], p. 22.

Holding staff, in Brooklyn Mus. 50.77. KAPLONY, *Studien*, figs. on pp. 60-1, cf. pp. 56-62; COONEY, op. cit. front cover and figs. 9-12, pp. 11-17; *Brooklyn Mus. Ann. Rep. 1950-1*, fig. on p. 9; *I.L.N.* Oct. 10, 1953, fig. on p. 563 [upper left]; HARRIS, *Egyptian Art*, pl. 12; YOYOTTE, *Treasures*, pl. on p. 33; WOLF, *Kunst*, Abb. 141, p. 175; ANTHES, *Aeg. Plastik*, Taf. 15; VANDERSLEYEN, *Das Alte Ägypten*, Abb. xii. Upper part, MAZAR, *Views*, iv, pl. 69. Text, JAMES, op. cit. pl. xxiii [55], pp. 21-2.

In long kilt, in Brooklyn Mus. 51.1. KAPLONY, *Studien*, figs. on pp. 63-4, cf. pp. 62-4; COONEY, op. cit. figs. 2-7, pp. 4-10; *Eg. Art . . . Brooklyn*, figs. 22; *Brooklyn Mus. Ann. Rep. 1951-2*, fig. on p. 8; *The Brooklyn Museum. Five Years of Collecting Egyptian Art, 1951-1956*, pls. 4-6, pp. 1, 2 [1B]; *Handbook* (1967), pls. on pp. 51, 53; *Brief Guide* (1970), front cover and pl. on p. 28; (1974), frontispiece and pl. on p. 28; *I.L.N.* Oct. 10, 1953, fig. on p. 563 [upper middle]; *Great Museums*, fig. on p. 194 [23]; DAUMAS, *Civ. de l'Ég.* pl. 43; MICHALOWSKI, *Art*, figs. 73, 230; WOLF, *Kunst*, Abb. 142, p. 175; POSENER, SAUNERON and YOYOTTE, *Dict. civ.* fig. on p. 93; WOLDERING, *Götter*, Taf. x on p. 79. Upper part or head, ANTHES, *Aeg. Plastik*, Taf. 14; BRUNNER in *Archiv für Orientforschung*, xviii (1957-8), Abb. 1, p. 436; PIRENNE, *Hist. civ.* i, pl. 58 between pp. 180-1; WESTENDORF, *Das Alte Ägypten*, fig. on p. 52; BRUNNER-TRAUT, *Die Alten Ägypter*, Taf. 1; DAVID, *The Egyptian Kingdoms*, fig. on p. 71. Text, JAMES, op. cit. pl. xxiii [57], p. 22.

In long kilt and wearing necklace, in Kansas City, William Rockhill Nelson Gallery of Art, 51-1. KAPLONY, *Studien*, figs. on pp. 68-70; COONEY, op. cit. figs. 1, 13, pp. 1, 19; id.

¹ More likely from the tomb of Ni'ankhnesut, p. 694.

in *Apollo*, xcvi (1972), pl. i, fig. 1, p. 475; *J.L.N.* Aug. 4, 1951, figs. on p. 196; PRITCHARD, *Anc. Near East*, fig. 15; STAEHELIN, *Tracht*, Taf. xviii [26], p. 110; Kansas City. *Handbook of the Collections* (1959), figs. on pp. 15 [middle], 18; ALDRED in PIGGOTT, *The Dawn of Civilization*, pl. on p. 115 [40]. Upper part, SMITH, *Art . . . Anc. Eg.* pl. 54, p. 77; MÜLLER, *Äg. Kunst*, Abb. 42.

(c) LATE AND PTOLEMAIC PERIODS

Plan, BARSANTI in *Ann. Serv.* ii (1901), fig. on p. 246.

ESBANEBDED , Overseer of the Two Granaries, etc. Dyn. XXVI.

Map LXI.

Parents, Ḥaremḥēt  and Tares .

Sarcophagus. Texts, BARSANTI in *Ann. Serv.* i (1900), pp. 189–90.

Four canopic-jars, in Cairo Mus. JE 34162. See id. *ib.* p. 190 with note 1.

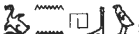
THANENHEBU , Overseer of royal freight-boats, etc. Temp. Amasis.

Map LXI.

Mother, Tanefertiti .

BRESCIANI, PERNIGOTTI and SILVIS, *La tomba di Ciennehebu, capo della flotta del re.*

Substructure with vaulted tomb.

Plan and sections, BARSANTI in *Ann. Serv.* i (1900), figs. 1–4 on pp. 263, 265; with views, BRESCIANI [etc.], Tav. ii–v, cf. i.

Offering-texts and list, Pyramid-texts, and coffin-texts, on walls of burial chamber. Id. *ib.* Tav. vi–xii, pp. 25–40, 42; BARSANTI in *Ann. Serv.* i (1900), p. 266; MASPERO in *ib.* pp. 272–80.

Four canopic-jars, in Cairo Mus. JE 34330. PERNIGOTTI in BRESCIANI [etc.], Tav. xxiv, xlili, xliv, pp. 56–8, 63–4. See BARSANTI, *op. cit.* p. 264.

Anthropoid sarcophagus, basalt, in Cairo Mus. JE 35156. PERNIGOTTI in BRESCIANI [etc.], Tav. xiii–xix, pp. 45–51, 59–61. Texts, MASPERO, *op. cit.* pp. 280–2. See BUHL, *Sarcophagi*, p. 22 [A, 3] (as Temp. No. 18.11.14.15), cf. pl. i.

Inscribed cloth. Text, BARSANTI, *op. cit.* pp. 267–8.

Gold pendants, in Cairo Mus. (a) Plaque with vulture on *recto* and text from Book of the Dead on *verso*, CG 53247, (b) collar-form, with text from Book of the Dead, CG 53249. VERNIER, *Bijoux et orfèvreries (Cat. Caire)*, ii, on pl. xcvi; i, pp. 410, 411; SILVIS in BRESCIANI [etc.], Tav. xxxiv, xl [on left upper], pp. 82–3, 94; MASPERO in *Ann. Serv.* iii (1902), pls. i [5, 6], ii [1, 2], pp. 2–3; id. *Essais*, figs. 85, 84, p. 257; id. *Eg. Art*, pl. facing p. 202 [top], cf. p. 203; see id. *Guide*, p. 437 [4121]; BARSANTI, *op. cit.* p. 270 [JE 34474], 271 [JE 43476].

Inscribed gold band, fragments, in Cairo Mus. CG 53800. SILVIS in BRESCIANI [etc.], Tav. xxxi [left and upper right], p. 79. See VERNIER, *op. cit.* pp. 503–4; MASPERO, *Guide*, p. 437 [4117].

PSAMMETHEK $\square \parallel \overline{\text{A}} \overline{\text{B}}$, Greatest of the physicians, etc. Perhaps temp. Amasis.

Map LXI.

Parents, Ḥarsiēsi (from stela in Louvre, IM.4084, see *infra*) and Tagemirēsi $\overline{\text{A}} \overline{\text{B}} \overline{\text{C}} \overline{\text{D}}$.
BRESCIANI, PERNIGOTTI and SILVIS, *La tomba del medico Psammetico* (in preparation).

Substructure. Plan and sections, BARSANTI in *Ann. Serv.* i (1900), figs. 1-3 on pp. 161-3.

Vaulted tomb.

Inner walls. Texts from Book of the Dead, Pyramid-texts, and offering-list, MASPERO in *ib.* pp. 167-80.

Outer sarcophagus. Texts, BARSANTI, *op. cit.* pp. 163, 164.

Inner anthropoid sarcophagus. Inscribed body; see *id. ib.* p. 164. Lid, basalt, in Berkeley, Univ. of California, Lowie Mus. of Anthropology, 5.522; upper part, ELSASSER and FREDRICKSON, *Ancient Egypt. An Exhibition at the Robert H. Lowie Museum of Anthropology of the University of California, Berkeley. March 25-Oct. 23, 1966*, fig. on p. 80; *Treasures of the Lowie Museum. Exhibition . . . Jan. 2-Oct. 27, 1968*, frontispiece; detail, *Archaeology*, 6 (1953), fig. on p. 185 [left]; part of texts, MASPERO, *op. cit.* pp. 183-4.

Subsidiary burial chamber. Setyerboni $\overline{\text{A}} \overline{\text{B}} \overline{\text{C}}$ (woman).

Four canopic-jars, in Cairo Mus. JE 34078. See BARSANTI, *op. cit.* pp. 161-2.

PEDENĒSI $\overline{\text{A}} \overline{\text{B}} \overline{\text{C}}$, Secretary of the royal weaving, Overseer of sealed documents, Overseer of the place, etc. Temp. Amasis.

Map LXI.

Parents, Psammethek and Desnub $\overline{\text{A}} \overline{\text{B}}$.

BRESCIANI, PERNIGOTTI and SILVIS, *La tomba del Ciambellano Pediesi* (in preparation).

Substructure. Plan and sections, BARSANTI in *Ann. Serv.* i (1900), figs. 1-4 on pp. 230-3.

Inner walls of vaulted tomb. Offering-texts of deceased and Ka $\overline{\text{A}}$, son of Tashenēsi $\overline{\text{A}} \overline{\text{B}} \overline{\text{C}}$ (mother), offering-list, and Pyramid-texts, *id. ib.* p. 232; MASPERO in *ib.* pp. 237-59.

Sarcophagus, anthropoid, basalt, in Cairo Mus. JE 34648. BUHL, *Sarcophagi*, fig. 1, pp. 20-1 [A, 1], cf. pl. i. Texts, MASPERO, *op. cit.* pp. 259-61.

PEDENEIT $\overline{\text{A}} \overline{\text{B}} \overline{\text{C}}$, Head of the stable, Overseer of horses. Probably late Dyn. XXVI.

Map LXI.

Parents, 'Ankhpekhrod $\overline{\text{A}} \overline{\text{B}} \overline{\text{C}}$ and Ḥetepubaste $\overline{\text{A}} \overline{\text{B}} \overline{\text{C}}$.

BARSANTI in *Ann. Serv.* ii (1901), pp. 97-104, with plan and sections, figs. 1-4.

Vaulted tomb at bottom of shaft.

North wall. Deceased adoring Osiris, *id. ib.* fig. 5, pp. 98-9; list of oils and Pyramid-texts, MASPERO in *ib.* pp. 109-10.



East wall. Anubis-jackal on chest with canopic-jars (above niche), BARSANTI, *op. cit.* fig. 6, p. 100 (with offering-text); Pyramid-texts, MASPERO, *op. cit.* pp. 107-8.

South wall. Pyramid and other texts, *id. ib.* pp. 110-11; BARSANTI, *op. cit.* pp. 101-2.

West wall. Anubis-jackal on chest with canopic-jars (above niche), id. ib. fig. 7, p. 101 (with offering-text); offering-list and Pyramid-texts, MASPERO, op. cit. pp. 104-7.

Finds

Canopic-jars, alabaster, in Cairo Mus. JE 34679. See BARSANTI, op. cit. p. 99.

AMENTEFAKHT  H A C A E B R E (-MERYPTAH )
Overseer of the life-guard, Director of recruits of the King of Lower Egypt, etc. Dyn. XXVI.

Map LXI.

Mother, Irterau .

SAAD in *Ann. Serv.* xli (1942), pp. 382-91, with view, plan and sections, figs. 75-9 = id. *Royal Excavations at Saqqara and Helwan (1941-1945)* in *Ann. Serv. Cahier*, 3 (1947), pp. 2-11, with figs. 1-5; id. in *Ann. Serv.* xl (1940), p. 693 with pl. lxxxii; SCHWEITZER in *Orientalia*, n.s. 17 (1948), pp. 264-5. Names and titles, DE MEULENAERE, *Le Surnom égyptien à la Basse Époque*, p. 4 [7].

Vaulted tomb at bottom of shaft.

Interior walls. Pyramid-texts, offering-list, etc.; DRIOTON in *Ann. Serv.* lii (1954), pp. 107-22; some, see SAAD, op. cit. pp. 386-8 (= pp. 6-8).

Sarcophagi. Outer; text of lid, DRIOTON, op. cit. pp. 105-6; SAAD, op. cit. p. 385 (= p. 5). Inner, anthropoid, lid with Pyramid-texts, green schist; view, id. ib. pls. xxvi, cf. xxvii, pp. 389-90, with some texts (= pls. i, cf. ii, pp. 9-10); texts, DRIOTON, op. cit. pp. 106-7.

HEKAEMSAF , Overseer of royal freight-boats, etc. Temp. Amasis.

Map LXI.

Plan and sections, BARSANTI in *Ann. Serv.* v (1904), figs. 1-4 on pp. 70-2.

Vaulted tomb at bottom of shaft.

Walls. Pyramid-texts, offering-texts and offering-list, id. ib. pp. 73-4 [top and middle]; MASPERO in ib. pp. 78-83.

Text of Chapter 72 of Book of the Dead, on lid of outer sarcophagus, BARSANTI in ib. pp. 74 [bottom]-75.



Gold mask and inscribed band, from wooden coffin and mummy, in Cairo Mus. CG 53668. VERNIER, *Bijoux et orfèvreries (Cat. Caire)*, ii, pl. ciii; i, pp. 478-80; VILÍMKOVÁ, *Chefs-d'œuvre*, pl. 85; see BARSANTI, op. cit. pp. 75-6.

Four canopic-jars, alabaster, in Cairo Mus. JE 35901. See id. ib. p. 72 with note 2.

Three small clay boats, in Cairo Mus. JE 35920-2. See id. ib. p. 73.

PTOLEMAIC TOMB. Just outside south enclosure wall of Step Pyramid. Exact position unknown. Found in 1926.

Sketch-plans, photographs of finds, and description, QUIBELL in GUNN MSS. xxii.

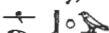









Statuettes of Ptah-Sokari-Osiris, wood. (a) Tai(?) , son of Neb-hepar-bener(?) (coffin No. 20 in N. chamber), containing ear of corn wrapped in cloth. (b) Khe(n)sui , son of Setyerboni  (mother). (c) Herubaste (coffin No. 19 in W. chamber).

South-east chamber. Re-used burial chamber of an Old Kingdom tomb.















Twelve wooden statues and statuettes (three inscribed) of Ihy , Overseer of the Two Granaries, etc., Dyn. VI. Two, Ihy in long and short kilt, in Neuchâtel Mus. Eg. 424-5; GABUS, *La Collection égyptologique* [etc.] in *Formes et Couleurs*, xi [i] (1949), 6th and 7th figs.; id. *175 ans*, Pt. 2, pls. 6, 7 on pp. 166-7, cf. Pt. 1, p. 55 [1, 2]; Eg. 425, MICHALOWSKI, *Art*, fig. 233; Essen. *5000 Jahre*, No. 35 with Abb. (as Geneva and Niʿankhnesut). Three, in New York, M.M.A. 27.9.3-5; in short and long kilt, Nos. 27.9.5. and 3, PISOÁN, *Summa Artis*, iii (1945), figs. 218-19.

Thirteen coffins. No. 2, wooden coffin of Zehō .

West chamber.

Twenty-four coffins (those inscribed all wooden). No. 5, Meribenptah , Guardian of the Temple of Ptah, son of Tadeimhōtep  (mother). No. 13, Imhōtep, son of Renpet-ankh  (mother). No. 14, Taihet-ankhti  (woman). No. 18, Merptah . No. 19, Herubaste , son of Tashentihet  (mother). No. 20, ʿAnkh-ḥapi . No. 22, Harkhet(?) . No. 23, Sekhem-ubaste .

North chamber.

Twenty-six coffins (those inscribed all wooden). No. 1, Irḥap , son of Pames . No. 14, Wenḥerpe(?) , son of Khens-iuemmatet(?) . No. 15, Ḥep-nebmatet , son of Dḥout-enmekhat  and Teru . No. 19, Zehō . No. 20, Tai(?) , son of Neb-ḥepar-bener . No. 21, Khe(n)siu . No. 23, Khe(n)siu , son of Herubaste  (mother). No. 25, Ḥor. No. 26, Imhōtep, son of Peb-ḥep-weret(?) .

Lower chamber.

Planks from wooden coffin of Amenardais , son of Pedehor and Tadeptah.

Family-tomb of KANŪFER¹ , *wnrvw*-priest, Scribe of the Temple of Ptah, etc.
Probably Dyn. XXX.

Exact position unknown.



Mother, ʿSireshti .

BRINTON in *Archaeology*, 2 (1949), pp. 142-5, with plan and views; BATRAWI in *Ann. Serv.* 1 (1950), pp. 477-9, cf. 479-91, with plan, fig. 1, and view of coffin and mask, pls. iii, cf. i, ii; *Chron. d'Ég.* xxiv (1949), p. 241 [lower].

Brick with cursive magical text, and dish with painted figures of divinities, found near coffin of deceased (No. 3 in Room C of BATRAWI). DRIOTON, *La magie dans l'Égypte des Pharaons* in *Formes et Couleurs*, xi [1] (1949), 1st and 6th figs.



(d) FINDS FROM THE AREA AROUND THE PYRAMID-COMPLEX OF UNIS

Statues.

Double-statue, Sermatet , Overseer of the house of accounts of Lower Egyptian barley in ʿAnkh-tauī, etc., and small figure of wife Khnemt , with offering-text mentioning Unis, end of Dyn. XII, found in the Valley Temple. MOUSSA and ALTENMÜLLER in



¹ The titles and hieroglyphs of the names from an ushabti, BRESCIANI in *Studi classici e orientali*, xviii (1969), pp. 126-8 with pl.



Mitt. Kairo, 31 (1975), Taf. 32, pp. 93-7 with Abb. 1; see ALTENMÜLLER in *Studien zur altägyptischen Kultur*, 1 (1974), p. 1.

Statue-group, Osiris, Isis, and Nephthys, dedicated by Haremhab , son of Peftue'aupep , granite, Dyn. XXX, found at north-east corner of the Pyramid, in Cairo Mus. CG 39220. DARESSY, *Statues*, pl. lviii, pp. 304-5; MURRAY, *Sculpture*, pl. xlvii [2]; PERC, *Spomeniki starega Egipta* (1974), No. 37 with fig. Text, BARSANTI in *Ann. Serv.* i (1900), p. 285. See Vienna. 5000 Jahre, p. 93 [199].

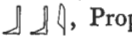
False-doors and stelae.

Memi , Overseer of scribes, etc., Dyn. V-VI, found west of the Pyramid, in Cairo Mus. CG 57168 (JE 36808).

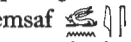
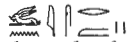
Nubhotp  Bebi , Prophetess of Hathor in the *mert*-temple of Unis, etc., mentioning Khenu , Noble of the King, Dyn. VI. SAAD in *Ann. Serv.* xl (1940), fig. 72, p. 683.

Unisemsaf  Lector-priest, son of Unis-ergesptah  and Sitip , mentioning Unis in offering-text, Middle Kingdom, found south of the Causeway. MOUSSA in *Mitt. Kairo*, 27 (1971), Taf. xiii, xiv, pp. 81-4.

Blocks.

Five fragments with remains of text concerning mortuary endowment, end of Dyn. V or early Dyn. VI. GOEDICKE, *Rechtsinschriften*, Taf. xi [a], pp. 104-7 (referring to Taf. viii [a]); one fragment (No. 1 of GOEDICKE), FISCHER in *Mitt. Kairo*, 16 (1958), Taf. xi, fig. 1, pp. 131-7.



Remains of text of purchase of tomb (*hwt-ks*), Dyn. V-VI, found north of the Valley Temple. GOEDICKE, op. cit. Taf. xvii [a], pp. 174-7 (referring to Taf. xii [b]).





Block with five estates of Ptaḥshepses , Dyn. V-VI. Names of estates, JACQUET-GORDON, *Domaines*, p. 403 [29S5-6], cf. fig. 163.

Block with two estates of Ptaḥshepses (probably not same man as last), Dyn. V (?). Names of estates, id. ib. p. 352 [14S5].

Two fragmentary lintels, one of them of Meru , late Old Kingdom. GUNN MSS. xviii. 62 [1, 2] (photos.).

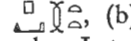
Coffins.

Unis-akhi  Akhi , Overseer of the department of the Great House, rectangular, wooden, Dyn. VI. GUNN MSS. xviii. 65 (photos.).

Three, (a) Pedeneit , (b) Irterau , (c) Hager , daughter of Harwoz , all wooden, Late Period. (a) and (c), *I.L.N.* Jan. 8, 1966, figs. on pp. 16 [lower], 17; (a) *Egypt Trav. Mag.* Nos. 139/40 (May-June 1966), fig. on p. 10.

Various.

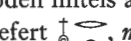
Two wooden lintels and door-wing of Itisen , Overseer of faience-workers, etc., and wife Nefert , *mitrt*, probably late Dyn. V. MOUSSA in *Mitt. Kairo*, 28 (1972), Taf. xxix (door-wing), pp. 289-91.

Faience statuette of Bes with cartouche of Takelothis II, from fan, in Cairo Mus. JE 86161. SAAD in *Ann. Serv.* xlii (1943), pl. xiii, cf. figs. 25-7, pp. 147-9; LEIBOVITCH, *La plume d'autruche* in *Formes et Couleurs*, xi [1] (1949), fig. 13.

Faience lotiform chalice with marsh motives in relief, 3rd Int. Period. SAAD in *Ann. Serv.* xl (1940), pl. lxxvii [lower], p. 681 (not specifically mentioned); TAIT in *J.E.A.* 49 (1963), pl. xiii [4], pp. 103-4 [1].

Models in Neuchâtel Museum, boats (Eg. 356-7), servants and offering-bringers (Eg. 360-3), bakers and brewers (Eg. 364-7), and potters (Eg. 368), Dyn. VI or 1st Int. Period, from shaft serdab south of Step Pyramid enclosure. *Museum*, xviii [2] (1965), on fig. 1 on p. 66. Two bakers and a brewer (Eg. 365), and one boat (Eg. 357), with description of others, GABUS, *175 ans*, Pt. 2, pls. 3, 4 on pp. 163-5, cf. Pt. 1, pp. 55-6 [5-11, 13-15]. Boats, see FIRTH in *Ann. Serv.* xxvi (1926), p. 101.

G. BETWEEN THE MONASTERY OF APA JEREMIAS AND THE ENCLOSURE OF SEKHEMKHET

Position of Lepsius tombs, L. D. i. on 33.

(a) OLD KINGDOM

LS 31. ПТАḤḤOTP $\frac{\square}{\triangle} \frac{\frac{\square}{\triangle}}{\square}$, Chief Justice and Vizier, etc. Middle Dyn. V or later.

Plan LXVI.

L. D. *Text*, i, pp. 185-6, with plan. Plan and section, L. D. i. 42.

Pillared Hall I.

(1) On right, [deceased seated] with wife squatting, and three remaining registers of rewarding female weavers, including scene with corn-measurers in granary.

Id. ib. ii. 103 [a]; JUNKER, *Gîza*, v, Abb. 10, pp. 48-51 [β].

(2) On right, deceased with son Ptaḥḥotp, Royal chamberlain, etc., with remaining registers, I-III, freight-boats, and below, IV, attendants and freight-boats.

L. D. ii. 103 [b], 104 [b]. Some boats, DÜMICHEN, *Flotte*, Taf. xxvii [7-11].

(3) Deceased with son Ptaḥḥotp, and three remaining registers of men bringing cattle. Right of it, five registers (top almost completely lost) of tending gazelles, oryxes and cattle.

L. D. ii. 102, and *Text*, i, fig. on p. 185 [left].

(4)-(5) [1st ed. 5, 4] Registers (I-III partly above doorway), I, offerings, and figures of divinities(?) seated, II, men with staffs, female dancers and clappers, men before canopy with coffin(?), III, two boats with shrines with coffin being towed, man bringing haunch in canoe, and offerings, IV, boat with shrines with coffin being towed by another three boats and men on bank, and offerings and chests with feathers on top.

L. D. ii. 101 [b], and *Ergänz.* xliii [b]. Left boat with shrines, and man in canoe, in III, and two towing-boats in IV, DÜMICHEN, op. cit. Taf. xxvii [5, 6]. Women mourners, see WERBROUCK, *Pleureuses*, p. 16.

Pillars. Titles and name on east faces, L. D. ii. 103 [c].

Room II.

(6) Thickness of doorway. Two registers of men bringing oryx, ibex, and cattle.

Id. ib. ii. 104 [d].

(7) Registers, I, bringing cattle, II, butchers, III-IV, offering-bringers.

L. D. *Ergänz.* xliii [a].

(8) [1st ed. incorrectly placed] Register of men bringing cattle.

L. D. ii. 104 [a].

Room IV.



- (9) Thickness of doorway. Men censuring and dragging statue.
Id. ib. ii. 104 [c].

OLD KINGDOM FINDS

Block, man in canoe spearing fish, with hippopotamus below, Dyn. V-VI. QUIBELL, *Saqqara* (1907-8), pl. li [3], p. 112.

Block, sower, and heads of men with rams treading grain, and shepherd's song, Dyn. V-VI, in Cairo Mus. JE 41572. Text, id. ib. (1908-10), p. 146 [top]; KAPLONY in *Chron. d'Ég.* xlv (1969), pp. 30 [A], cf. 28, 29, 31; ALTENMÜLLER in ib. xlviii (1973), pp. 212 [4], cf. 213.

(b) NEW KINGDOM

TIA  (also )^c, Overseer of the Treasury in the Temple of Usermaetetrê-setepenrê^c (Ramesses II) in the domain of Amûn, Fan-bearer on the right of the King, etc. Temp. Ramesses II.

Map LXII.

Wife, Tia, King's noble sister, Songstress of Amûn Great-of-Victories, etc.

Position, see MARTIN in *J.E.A.* 62 (1976), p. 13 note 13.

Stela, two registers, I, Ramesses II offering flowers to Ptah, II, deceased kneeling in adoration, in Florence Mus. 2532. BOSTICCO, *Le stele egiziane del Nuovo Regno*, figs. 54, 54a-c, pp. 61-2. II, PETRIE ITAL. photo. 254. Edges with titles of wife, HABACHI in *Rev. d'Ég.* 21 (1969), fig. 14, pp. 43-4 [2]. Text, BEREND, *Principaux monuments*, p. 45; SCHIAPARELLI, *Mus. Arch. Firenze*, pp. 323-4 [1598]. Some titles, LIEBLEIN, *Dict.* No. 904. See ROSELLINI, *Breve Notizia degli Oggetti di Antichità Egiziane* [etc.] (1830), p. 40 [43]; MIGLIARINI, *Indication*, pp. 11-12.

Pyramidion, granite, formerly in Lethieullier and Long Collns. GORDON, *Twenty-five Plates*, pls. i, ii (repr. MÁLEK in *J.E.A.* 60 (1974), pl. xxxv, fig. 2, pp. 165-7); *Fraser's Magazine*, Nov. 1837, No. 95, fig. on p. 629. See ZOEGA, *De Origine et Usu Obeliscorum* [etc.] (1797), p. 88 [vii].



Blocks, probably from here. (a) Upper parts of Tuy (mother of Ramesses II), deceased and wife, in Toronto Mus. 955.79.2; *The Brooklyn Museum. Five Years of Collecting Egyptian Art, 1951-1956*, pl. 51 [lower], pp. 27-8; HABACHI, op. cit. fig. 13, pp. 42-3 [1]. (b) Deceased (not named), wife (end of name only) and son(?) before [a god], formerly in Eid Colln. 4260; ZAYED, *Egyptian Antiquities*, fig. 16, pp. 13-14; *Sotheby Sale Cat.* July 1, 1969, No. 62 with pl.; see ZIVIE (C. M.), *Giza*, p. 209 [NE 62,3]. (c) Man and wife (no names) before shrine with Hathor-cow protecting King, formerly in Eid Colln. 4216; ZAYED, op. cit. fig. 5, pp. 6-7; *Sotheby Sale Cat.* July 1, 1969, No. 61 with pl.; *Christie Sale Cat.* July 11, 1973, No. 137 with pl. 9; see ZIVIE, op. cit. p. 209 [NE 62,2]. (d) Deceased and wife adoring cartouche of Ramesses II, at Orient-Occident (dealer in Paris) in 1973; see id. ib. p. 208 [NE 62,1]; MÁLEK, op. cit. p. 161 note 5. (e) Deceased and wife, and 8 columns of text, seen with a dealer in Cairo; see ZIVIE, op. cit. p. 209 [NE 62,4].

Sarcophagus-fragment, with ibis-headed god, granite, in Copenhagen, Ny Carlsberg Glypt. Æ.I.N.48. SCHMIDT, *Choix* (1910), pl. x [21], p. 26 [E.117]; id. *Levende og Døde*, fig. 648; HABACHI, op. cit. fig. 15, p. 44 [3]; KOEFOED-PETERSEN, *Catalogue des sarcophages*

et cercueils égyptiens, pl. xx, p. 14 [5]. Name and title, id. *Rec. inscr.* p. 86 [48]. See SCHMIDT (V.), *Den Æg. Sam.* (1908), pp. 188-9 [E.117].

PAY  , Overseer of the royal apartments of the King's wife, etc. Dyn. XIX.

Map LXII.



Father, Amenemḥab  , Judge.

See DE MEULENAERE in *Chron. d'Ég.* 1 (1975), pp. 87-8 [b], 88 [d]; MARTIN in *J.E.A.* 62 (1976), p. 13 note 13.

Jamb-fragment with names and titles, and block with remains of offering-list, in Florence Mus. 2600-1. Texts, SCHIAPARELLI, *Mus. Arch. Firenze*, pp. 338-41 [1605-6]; BEREND, *Principaux monuments*, pp. 95-6. No. 2600, names and titles, LIEBLEIN, *Dict.* No. 2113; BRUGSCH, *Thes.* 1447 [62]; see ROSELLINI, *Breve Notizia degli Oggetti di Antichità Egiziane* [etc.] (1830), p. 18 [8].

Two joining blocks, three scenes of priests making libation outside kiosks, in Paris, Musée Rodin, 235 and 104 (latter formerly in Louvre, E.15562). See *Rodin collectionneur. Musée Rodin, Paris, 1967-1968*, No. 32.

Pyramidion, four faces, (a) Rēc-Ḥarakhti seated, (b) deceased kneeling adoring, (c) niche with deceased adoring, (d) Anubis-jackal, in Louvre, D 21 [N.362]. ARCHIVES phot. E.807. (a) and (d) VANDIER, *Manuel*, ii, fig. 306 [upper right and middle]. Texts, PIERRET, *Rec. inscr.* ii, pp. 31-2. See DE ROUGÉ, *Notice des monuments* (1883), pp. 188-9; BOREUX, *Guide*, i, p. 119; VANDIER, *Guide* (1948), p. 23; (1952), p. 24; (1973), p. 37.

ḤAREMḤAB  , General, Deputy of His Majesty in the whole land, Chief steward, etc. (Later King.) Temp. Tutankhamūn or Ay.

Map LXII.

Accounts of excavation, mostly with plans, views, and some newly discovered scenes and statues, MARTIN in *J.E.A.* 62 (1976), pp. 5-13, with pls. i-iv, figs. 1, 2; 63 (1977), pp. 13-19, with pls. i-iii, fig. 1; 64 (1978), pp. 5-9, with pls. i-iv; id. in *I.L.N.* Aug. 1975, pp. 73, 75 with figs.; July 1976, pp. 61-2 with figs.; Jan. 1978, pp. 50-1 with figs.; id. in *Bull. Soc. fr. d'Ég.* Nos. 77-8 (Oct. 1976-March 1977), pp. 11-25 with figs.; SCHNEIDER in *Phoenix*, 22 (1976), pp. 1, 3-35 with figs.; LECLANT in *Orientalia*, n.s. 45 (1976), p. 284 [k] with pls. xviii-xix [6, 7].

Thicknesses of doorway to Statue Room, titles and deceased at table. MARIETTE, *Mon. div.* pl. 74 (inaccurate); text, DE ROUGÉ, *Inscr. hiéro.* pls. cvii, cviii; HARI, *Horemheb*, pl. xiv (from MARIETTE and DE ROUGÉ), pp. 88-9. Titles, LEGRAIN, *Répertoire*, No. 314 [lower] (as Cairo Mus.).

Text of hymn to Rēc (remains on west wall of Columned Court), DE ROUGÉ, op. cit. pls. civ-cvi; see HARI, op. cit. pp. 98-100.

Blocks and other monuments removed from the tomb

Suggested original position of blocks in museums (now to be amended), HARI, op. cit. pp. 80-5, cf. pls. xvi, xviii.

Berlin (East) Museum.

Bowing courtiers, and text above, No. 22663 (adjoining Vienna Mus. Inv. 214 and Leyden

Mus. Inv.H.III.QQQQ). SCHÄFER in *Berliner Museen*, xlix (1928), Abb. 1, cf. 3, pp. 34-40; id. *Amarna in Religion und Kunst*, Taf. 58; id. and ANDRAE, *Kunst* (1930), 385 [right]; Burg & Co. *Katalog der Ausstellung ägyptischer Kunst*. Berlin, 1929, Taf. x, pp. 16-17 [62]; LANGE (K.), *König Echnaton und die Amarna-Zeit*, pl. 50; GARDINER in *J.E.A.* 39 (1953), fig. 3, p. 5 note 1, cf. fig. 2 (text, with that of Vienna block), pp. 6-9. See *Führer* (1961), p. 64.

House, men with chariot and horses, donkeys, etc., No. 20363 (adjoining Bologna 1888). SCHÄFER in *Amtliche Berichte aus den Preuss. Kunstsammlungen*, xl (1918-19), Abb. 77, cols. 153-63; id. and ANDRAE, *Kunst* (1925), 354 [2]; (1930), 370 [2]; (1942), 385 [2]; CAPART in *J.E.A.* vii (1921), fig. 1 [upper] on p. 33; WRESZ., *Atlas*, i, 386 [B]; CURTO, *L'Egitto antico* (1961), Tav. 31 [B], p. 84; id., FIORA and FOLLO in *Il Carrobbio*, i (1975), Tav. 5 [upper] on p. 84; *Führer* (1961), Abb. 39, pp. 62-3; HARI, *Horemheb*, fig. 19, pp. 73-6; *Ägyptisches Museum 1823-1973*, Abb. 26.

Bologna, Museo Civico (formerly Palagi Colln.).

Four registers of Fields of Iaru, No. 1885. CAPART in *J.E.A.* vii (1921), pl. v facing p. 31, cf. p. 34; CURTO, *L'Egitto antico* (1961), Tav. 27, p. 82 [50]; id., FIORA and FOLLO, op. cit. Tav. 2, 7, 9 on pp. 82, 86-7, 90-1; HARI, op. cit. fig. 20, pp. 76-8; *Pelagio Palagi, artista e collezionista* (Bologna, Museo Civico, April-June 1976), No. 480 with fig.; SÉE, *Grandes villes*, fig. on pp. 252-3. Deceased as cattle-drover in II, BREASTED, *History*, fig. 150; adoring *benu*-bird, and at table, in III, BRESCIANI, *La collezione egizia nel Museo Civico di Bologna*, Tav. 19, pp. 44-5. See KMINÉK-SZEDLO, *Catalogo di Antichità Egizie*, pp. 169-70; DUCATI, *Guida*, p. 58 [E].

Men preparing offerings, etc., No. 1886. CAPART, op. cit. pl. vii facing p. 34; CURTO, op. cit. Tav. 28 [51], pp. 82, 84; id., FIORA and FOLLO, op. cit. Tav. 3 on p. 83; HARI, *Horemheb*, fig. 16, pp. 73-6; SÉE, op. cit. fig. on pp. 296-7 [lower]; GARDINER MSS. photo. 28. 408-9. Right part, PETRIE ITAL. photo. 214. See KMINÉK-SZEDLO, op. cit. p. 170; DUCATI, op. cit. p. 58 [F]; *Pelagio Palagi, artista e collezionista* [etc.], no. 482.

Counting Negro captives,¹ No. 1887 (also 1869). Complete, DUCATI, op. cit. fig. on p. 57, cf. p. 58 [D]; LANGE, *Lebensbilder*, pl. 37; MÜLLER, *Äg. Kunst*, Abb. 135; CURTO, op. cit. Tav. 32 [54], pp. 82, 84; id., FIORA and FOLLO, op. cit. Tav. 6 on p. 85; HARI, *Horemheb*, fig. 14, pl. x [right], pp. 71-3; group with Negroes, VON BISSING, *Denkmäler*, ii, Taf. 81A; WEIGALL, *Anc. Eg. . . . Art*, 207; CAPART, *L'Art ég.* iii, pl. 552; LUGN, *Kunst*, fig. 68; RANKE, *The Art of Ancient Egypt*, and BREASTED, *Geschichte Aegyptens* (1936), 228; MURRAY, *Sculpture*, pl. xxxviii [1]; id. *Splendour*, pl. lxxiii [1]; POULSEN (F.), *Ägyptens Kunst* (1933), fig. 57; RAGAI, *L'Art*, pl. 16 [34]; BRUNNER, *Ägyptische Kunst* in *Die Kunst dem Volke*, No. 85 (1937), Abb. 59; PIJOÁN, *Summa Artis*, iii (1945), fig. 457; GALASSI in *Critica d'Arte*, n.s. ii (1955), fig. 280, p. 354; DONADONI, *Arte Egizia*, fig. 137; RANKE, *Meisterwerke*, Abb. 41; MÜLLER (H. W.) in *Encyclopedia of World Art*, iv, pl. 367 [bottom]; MICHALOWSKI, *Art*, fig. 491; VANDERSLEYEN, *Das Alte Ägypten*, Abb. 305; TRIGGER, *Nubia under the Pharaohs*, pl. 46; FERRI, *Il Museo Civico Archeologico di Bologna* (1974), fig. on p. 12. Details, SPRINGER, *Die Kunst des Altertums* (1923), Abb. 117; CAPART, *Documents*, ii, pl. 62; PIRENNE, *Hist. civ.* ii, pl. 80 facing p. 364; RACHET (G. and M. F.), *Dictionnaire de la civilisation égyptienne*, fig. on p. 111; BRESCIANI, *La collezione egizia nel Museo Civico di Bologna*, Tav. 22, p. 48; *Pelagio Palagi, artista e collezionista* [etc.], No. 481 with fig. Text, HELCK, *Urk.* iv. 2086 [803, B], cf. *Übersetz.* (1961), p. 392. See KMINÉK-SZEDLO, *Catalogo di Antichità Egizie*, pp. 164-5, 170-1 (text).

¹ Selected references.

Houses, people, etc., No. 1888 (adjoining East Berlin 20363). CAPART in *J.E.A.* vii (1921), pl. vi [lower], fig. 1 on p. 33 [lower]; CURTO, *L'Egitto antico* (1961), Tav. 30, 31 [53], pp. 82, 84; id. *L'arte militare presso gli antichi Egizi*, fig. on 31st p. [lower]; id., FIORA and FOLLO in *Il Carrobbio*, i (1975), Tav. 5 [lower] on p. 84; HARI, *Horemheb*, fig. 17, pp. 73-6; GARDINER MSS. photo. 28.411-12. Man with water-skin, CAPART, *Paysage*, fig. 42; id. *Documents*, ii, pl. 64. See KMINEK-SZEDLO, *Catalogo di Antichità Egizie*, p. 171; DUCATI, *Guida*, p. 59 [I]; Pelagio Palagi, *artista e collezionista* (Bologna, Museo Civico, April-June 1976), No. 483.

Military camp with chariots, horseman, men carrying log, etc.,¹ No. 1889. CHAMPOLLION, *Mon.* ccciv [I] (1st pl.), cccxxxix; ROSELLINI, *Mon. Civ.* cxx, cf. *Text*, iii, p. 244 note 2; ZARDETTI, *Sopra due antichi monumenti egiziani* [etc.], pp. 20-5, and pl. iii; CHABAS, *Études sur l'Antiquité Historique* [etc.] (1873), pl. iii facing p. 430; CAPART in *J.E.A.* vii (1921), pl. vi [upper] facing p. 33; DUCATI, *Guida*, p. 58 [H] with fig.; WINLOCK, *The Rise and Fall of the Middle Kingdom in Thebes*, pl. 24, p. 155; ASSELBERGHS, *Beeldende Kunst in Oud-Egypte*, fig. 27a; YADIN, *The Art of Warfare* [etc.], fig. on pp. 220-1; CURTO, *L'Egitto antico* (1961), Tav. 29 [52], pp. 82, 84; id. *L'arte militare presso gli antichi Egizi*, fig. on 31st p. [upper]; id., FIORA and FOLLO, op. cit. Tav. 4 on p. 83; TOUNY and WENIG, *Sport*, Taf. 27; ALDRED, *Tutankhamun's Egypt*, fig. 43; MÜLLER (H. W.) in *Encyclopedia of World Art*, iv, pl. 367 [middle]; HARI, *Horemheb*, fig. 18, pp. 73-6; SÉE, *Naissance*, fig. on p. 308; Pelagio Palagi, *artista e collezionista* [etc.], No. 484 with fig.; omitting left end, VANDER-SLEYEN, *Das Alte Ägypten*, Abb. 303 [a]. Men with chariots, BRESCIANI, *La collezione egizia nel Museo Civico di Bologna*, Tav. 21, p. 47. Water-carrier, overseer, and horseman, MICHALOWSKI, *Art*, fig. 489. Horseman, and men carrying log, ALDRED, *N.K. Art* (1951), pls. 141-2; (1961), pls. 146-7; overseer and horseman, MASPERO, *Hist. anc.* ii, fig. on p. 219; horseman, PIRENNE, *Hist. civ.* ii, pl. 82 between pp. 364-5; *Sculptures et textes*, fig. on p. 99; PIJOÁN, *Summa Artis*, iii (1945), fig. 459; CAPART, *Documents*, ii, pl. 63; BILLE-DE MOT, *Die Revolution des Pharaos Echnaton*, Abb. 89. Men carrying log, SMITH, *Art . . . Anc. Eg.* pl. 144 [B]; Zurich. *5000 Jahre*, Abb. 51, p. 70 [180]. See KMINEK-SZEDLO, *Catalogo di Antichità Egizie*, p. 171.

Brooklyn Museum.

Soldiers acclaiming, including Minkhasy , Standard-bearer of the company 'Love of the Aten', No. 32.103 (to the right of Louvre, B 56). E. L. M. T[AGGART] in *The Brooklyn Museum Quarterly*, xix [4] (Oct. 1932), front cover, pp. 147-50; *Museums of The Brooklyn Institute of Arts and Sciences. Report . . . 1932*, fig. facing p. 12; ib. 1935, fig. on p. 37; COONEY in *J.E.A.* 30 (1944), pls. i, ii, pp. 2-4; VANDIER in *Mélanges Syriens offerts à Monsieur René Dussaud*, ii, pl. i [right], pp. 811-12; WOLF, *Die Welt der Ägypter*, Taf. 85; *Eg. Art . . . Brooklyn*, fig. 48; CURTO, op. cit. Tav. 3 [right], p. 84 [C]; HARI, op. cit. figs. 33-4, 35 [right], pl. xvii [middle upper] (text), pp. 109-10; FAZZINI, *Art from the Age of Akhenaten*, fig. 17. First two pairs on right, HARRISON in *The Biblical Archaeologist*, xvi (1953), fig. 13, p. 89. Heads of first three pairs, ALDRED, *N.K. Art* (1951), pl. 140; (1961), pl. 145. Text, HELCK, *Urk.* iv. 2089 [near top], cf. *Übersetz.* (1961), p. 393; JAMES, *Corpus*, i, pls. lxxxiv [424], cf. xii, pp. 171-2.

Cairo Museum.

Four column-sections, deceased kneeling in adoration before divinities, JE 11332-4. MARIETTE, *Mon. div.* pl. 75 (reversed); CURTO, *L'Egitto antico* (1961), Tav. 6, 8 [a], figs. on pp. 78-9 (from MARIETTE), cf. p. 84 [I-N]; HARI, *Horemheb*, figs. 22-5, pls. xii, xiii (texts),

¹ Selected references.

pp. 85–8 (as Nos. 11625–6, 11628–9). Texts, DE ROUGÉ, *Inscr. hiéro.* pls. xxxvi, xxxvii. Name and some titles, LIEBLEIN, *Dict.* No. 979. Titles, LEGRAIN, *Répertoire*, No. 314 [upper]; on one section, HELCK, *Urk.* iv. 2089 [top], cf. *Übersetz.* (1961), p. 393. See MARIETTE, *Notice des principaux monuments . . . à Boulaq* (1864), pp. 251–2 [74–7]; MASPERO, *Guide to the Cairo Museum* (1906), p. 113 [289].

Chicago, Oriental Institute.

Foreigners adoring, No. 10591.

Florence Museum.

Four scribes, No. 2566 (adjoining Leyden Mus. Inv.H.III.CCCC). ROSELLINI, *Mon. Civ. Text*, ii, pl. facing p. 174 [2]; SCHIAPARELLI, *Mus. Arch. Firenze*, Tav. iv, p. 313 [1587]; PETRIE, *History*, ii, fig. 140; RANKE, *The Art of Ancient Egypt*, and BREASTED, *Geschichte Aegyptens* (1936), 232; BOTTI in *Studi Rosellini*, i, Tav. i [1], p. 23; MINTO, *Il Regio Museo Archeologico di Firenze*, fig. on p. 23 [upper left]; PIJOÁN, *Summa Artis*, iii (1945), fig. 435; ERMAN, *L'Égypte des pharaons*, pl. xxiii [b]; BYVANCK, *De Kunst*, pl. lvi [191]; ZADOKS-JOSEPHUS JITTA, *Het Nabije Oosten*, pl. 21; VAN WIJNGAARDEN in *Oudheidkundige Mededelingen*, xlii (1961), pls. xii [1], cf. xii [2] (with Leyden Mus. Inv.H.III.CCCC), pp. 19–24; DE WIT, *Oud-Egyptische Kunst*, fig. 128 after p. 208; LAURENT-TÄCKHOLM, *Faraos blomster*, pl. on p. 26; SAINTE FARE GARNOT, *L'Égypte*, fig. on p. 91 [middle]; CURTO, *L'Egitto antico* (1961), Tav. 70, p. 157 [405]; COHEN in *Archeologia*, No. 12 (Sept.–Oct. 1966), fig. on pp. 8–9; EKSCHEMITT, *Das Gedächtnis der Völker*, Abb. on p. 112 [lower]; PIRENNE, *Hist. civ.* ii, pl. 71 facing p. 313; DONADONI, *Arte Egizia*, fig. 158; id. in *Enciclopedia dell'Arte Antica Classica e Orientale*, iii, fig. 331; LECA, *Médecine*, inside front cover; MICHALOWSKI, *Art*, fig. 493; ALINARI photo. 3611; PETRIE ITAL. photos. on 204, 253. See ROSELLINI, *Breve Notizia degli Oggetti di Antichità Egiziane* [etc.] (1830), p. 35 [33]; MIGLIARINI, *Indication*, p. 27; BEREND, *Principaux monuments*, p. 71.

Leyden Museum. See BOESER, *Cat.* (1907), pp. 61–3 [47].

Deceased with upraised arms being decorated with collars, and registers,¹ I (bottom part only), fan-bearers, scribes (upper part in Florence Mus. 2566), and horses, II–III (upper part only of III), men bringing Syrian captives, Inv.H.III.CCCC. LEE MANS, *Aeg. Mon.* i, pls. xxxi, xxxii; BOESER, *Beschreibung*, iv, Taf. xxi, xxii; BREASTED, *History*, figs. 119, 148; VAN WIJNGAARDEN, *Meesterwerken*, pls. 44–7; *Gids* (1926), fig. on p. 81 [upper]; (1928), fig. on p. 88 [upper]; (1937), fig. on p. 114 [upper]; LANGE and HIRMER, *Aegypten. Architektur* (1957), pls. 200–3; (1967), pls. 206–9; CURTO, *L'Egitto antico* (1961), Tav. 7, p. 84 [E]; id., FIORA and FOLLO in *Il Carrobbio*, i (1975), Tav. 1 on p. 82; HARI, *Horemheb*, figs. 30–1, pl. xvii [middle lower] (text), pp. 102–9. Deceased and men decorating him, SÄVE-SÖDERBERGH, *Faraoner och människor*, pl. facing p. 144; MAZAR, *Views*, i, pl. 106 [upper]; MÜLLER, *Äg. Kunst*, Abb. 134; ALDRED, *Tutankhamun's Egypt*, fig. 46; SCHNEIDER in *Phoenix*, 22 (1976), figs. 21, cf. 22, p. 30; BREMMER, *Eg. kunst*, Nos. 42–3; DE BUCK, *Egyptische Verhalen*, pl. facing p. 64; MICHALOWSKI, *Art*, fig. 492; with 1st man with captive in II, WOLF, *Die Welt der Ägypter*, Taf. 86 [upper]; HERMANN in *Ä.Z.* 90 (1963), Taf. ix [a], p. 59; STRÖMBOM, *Egyptens Konst*, fig. 166; with 3rd–5th groups with captives, *Artefact*, pls. 59, 60, p. 38. Deceased and men decorating him, with 1st and 2nd groups with captives in II, DESROCHES NOBLECOURT, *Ancient Egypt* [etc.], pls. 27–8, 30–1; with some men from 1st–3rd groups, KLASSENS, *Egyptische Kunst*, pls. 32–3. Upper part of deceased, and heads

¹ Selected references.

of an Egyptian and two Syrian captives in **III**, MYŚLIWIEC, *Le Portrait royal dans le bas-relief du Nouvel Empire*, pls. lxxxv [194], lxxxvi [196]. Men bringing necklaces, DESROCHES-NOBLECOURT, *Tutankhamun*, fig. 129; MICHALOWSKI, *Nie tylko piramidy . . .*, pl. 81. **I-III** (omitting right ends), ROSS, *The Art of Egypt*, pl. on p. 166 [2]; RANKE, *The Art of Ancient Egypt*, and BREASTED, *Geschichte Aegyptens* (1936), 229; WOLF, *Kunst*, Abb. 501; GROLLENBERG, *Atlas de la Bible*, figs. 126-7; SCHNITZLER in *Z.D.M.G.* 108, n.f. 33 (1958), Taf. v-vii [9-12], pp. 59-60; PRITCHARD, *Anc. Near East*, figs. 49-51; VANDERSLEYEN, *Das Alte Ägypten*, Abb. 304. Groups of captives in **II**, mostly with parts of **I** and **III**, 1st and 2nd, WOLDERING, *Götter*, fig. on p. 238 [Kat. 72]; with Egyptians from 3rd, DAUMAS, *Civ. de l'Ég.* pl. 57; 1st and Egyptians in 2nd, ALDRED, *N.K. Art* (1951), pl. 143; (1961), pl. 148; Egyptian in 1st and heads of three men in 2nd, MURRAY, *Sculpture*, pls. xxxix [2], xl; upper part of captive in 1st, and two children and heads of two captives in 5th, PIRENNE, *Hist. civ.* ii, pls. 81, 79 between pp. 364-5; 1st-3rd, *Gids* (1953), fig. 11; upper parts of Syrian in 2nd and Egyptians in 3rd, PIJOÁN, *Summa Artis*, iii (1945), fig. 458; some men in 2nd and 3rd, ATARASHI, *Egypt*, pl. 87; some men in 2nd to 4th, LANGE, *Lebensbilder*, Abb. 34; heads of some men in 2nd-5th, CAPART, *Recueil*, i, pls. xxxv-xxxvii; 3rd-5th, BULLE, *Der schöne Mensch im Altertum* (1912), Taf. 22; ERMAN, *Die Welt am Nil*, Taf. 35; id. and RANKE, *Aegypten und aegyptisches Leben im Altertum* (1923), Taf. 42 [2]; STEINDORFF, *Kunst*, 247; GROENEWEGEN-FRANKFORT and ASHMOLE, *Art of the Ancient World*, fig. 82; two children, and heads of captives in 5th, RAGAI, *L'Art*, pl. 80 [151]; VERCOUTTER in GRIMAL, *Histoire mondiale de la femme. Préhistoire et antiquité*, 2nd pl. after p. 112 [left upper]. **III**, incomplete, MEYER, *Geschichte des Altertums*, ii (1928), Taf. i; id. in *Mitteilungen der Deutschen Orient-Gesellschaft*, No. 56 (Dec. 1915), Abb. 2-4, p. 10; heads of two Egyptians and a Syrian, BREMMER, *Eg. kunst*, No. 44; heads of some men, CAPART, *Documents*, i, pls. 52, 53 [B]. See LEEMANS, *Descr. rais.* p. 40 [C.1].

King (unnamed but probably Tutankhamun) and Queen, with remains of text behind them, and in front of them, text, and register (blocks with bowing courtiers from **I** in Berlin (East) Mus. 22663 and Vienna Mus. Inv.214), **II**, **1**, deceased, with text, **2**, deceased addressing interpreter, **3**, interpreter addressing foreign chiefs, with three sub-registers of Syrians leading horses beyond, Inv.H.III.PPPP, QQQQ. (A cast of the Vienna block in Leyden is shown in many publications.) BOESER, *Beschreibung*, iv, Taf. xxiii, xxiv, xxiva, xxivb; *Gids* (1926), fig. on p. 81 [lower]; (1928), fig. on p. 88 [lower]; (1937), fig. on p. 114 [lower]; VAN WIJNGAARDEN, *Meesterwerken*, pls. 48-51. Also showing the Berlin block, SCHÄFER in *Berliner Museen*, xlix (1928), Abb. 3, pp. 37-40; CURTO, *L'Egitto antico* (1961), Tav. 2, p. 84 [D]; HARI, *Horemheb*, figs. 36-40, pls. xvii [right], xix (texts), pp. 112-25; omitting King and Queen, STEINDORFF, *Kunst*, 246. Incomplete, SCHÄFER and ANDRAE, *Kunst* (1925), 369, 370 [upper], 371 [upper]; (1930), 385 [left], 386 [upper]; (1942), 383, 384 [upper] (some from BOESER); omitting Syrians with horses, WOLF, *Kunst*, Abb. 499, 500. King and Queen, CAPART, *Documents*, i, pl. 51; Queen, DANIEL-ROPS, *Le Roi ivre de Dieu*, fig. on p. 55. **II**, LEEMANS, *Aeg. Mon.* i, pls. xxxiii, xxxiv. **1**, GARDINER in *J.E.A.* 39 (1953), fig. 1, pp. 5-6. **2**, MICHALOWSKI, *Art*, fig. 490; interpreter, BREMMER, *Eg. kunst*, No. 45. **2** and **3** (sometimes without Syrians), BREASTED in *Ä.Z.* xxxviii (1900), figs. 1 (with Vienna block), cf. 2, pp. 47-50; id. *History*, fig. 147; HUNGER and LAMER, *Altorientalische Kultur im Bilde*, Abb. 36; BATES, *The Eastern Libyans*, pl. vi [3] facing p. 134; STEINDORFF, *Die Blütezeit des Pharaonenreichs* (1900), Abb. 136; (1926), Abb. 177; BYVANCK, *De Kunst*, pl. lii [179]; HERMANN in *Ä.Z.* 90 (1963), Abb. 12, p. 58. **3**, PIERSON, *De Achttiende Dynastie van Oud-Egypte*, 2nd pl. after p. 68; interpreter (sometimes both figures) and chiefs, ERMAN and RANKE, *Aegypten und aegyptisches Leben im Altertum* (1923), Taf. 39 [2]; ALDRED,

N.K. Art (1951), pl. 139; (1961), pl. 144; id. *Akhenaten*, pl. 77; *Gids* (1953), fig. 12; WOLDERING, *Götter*, Abb. 81; KLASENS, *Egyptische kunst*, pl. 34; POULSEN (V.), *Ägyptische Kunst. Neues Reich und Spätzeit*, pl. on p. 15; GROLLENBERG, *Atlas de la Bible*, fig. 128; PRITCHARD, *Anc. Near East*, fig. 5; DESROCHES-NOBLECOURT, *Ancient Egypt* [etc.], pl. 29; *Artefact*, pl. 61, p. 38; GIVEON, *Les Bédouins Shosou des documents égyptiens*, pl. iv, pp. 35–8 [Doc. 10]; BRUNNER-TRAUT, *Die Alten Ägypter*, Taf. 3; VANDERSLEYEN, *Das Alte Ägypten*, Abb. 303 [b]; heads of two chiefs, CAPART, *Documents*, i, pl. 53 [A]; Syrians with horses, STRÖMBOM, *Egyptens Konst*, fig. 111. Texts, including those on Berlin and Vienna blocks, HELCK, *Urk.* iv. 2084–6 [803, A], 2088 [E] (as pl. 30 of BOESER), cf. *Übersetz.* (1961), pp. 391–2, 393; PFLÜGER, *Haremhab und die Amarnazeit*, pp. 16 [lower], 19–22. See LEEMANS, *Descr. rais.* pp. 40–1 [C.2, 3].

Block with two decorated faces, (a) deceased adoring hawk-headed Rēc-Ḥarakhti seated, (b) remains of text mentioning Ḥathor Mistress of the Sycamore, Inv. CI [V.29]. BOESER, *Beschreibung*, iv, Taf. xxv; see LEEMANS, *Descr. rais.* p. 275 [V.29]. (a) CAPART, *Recueil*, pl. xxxviii; DE BUCK, *De Zegepraal van het Licht*, fig. 1, p. 12; id. *Egyptische Godsdienst in van der Leeuw, De Godsdiensten der Wereld*, Abb. 22, p. 81; VAN WIJNGAARDEN, *Meesterwerken*, pl. 43; HAAS, *Bilderatlas zur Religionsgeschichte*, fig. 21; HARI, *Horemheb*, fig. 11, pp. 59–61; upper part of deceased, MYŚLIWIEC, *Le Portrait royal dans le bas-relief du Nouvel Empire*, pl. lxxxvii [198]; text, WIEDEMANN in *Ä.Z.* xxiii (1885), p. 81; HELCK, *Urk.* iv. 2103 [808], cf. *Übersetz.* (1961), p. 399.

Leningrad, State Hermitage Museum.

Upper part of stela, deceased before Atum, Osiris, and Ptaḥ-Sokari, No. 1061. STRUVE, *Ermitazhnaya stela Kharemheba in Ezhegodnik Rossiyskogo instituta istorii iskusstv*, i (1921), pp. 91–109; BOSSE in *Ä.Z.* 72 (1936), Abb. 5, pp. 134–5 [II]; HARI, *Horemheb*, fig. 29, pl. xv, pp. 96–8; PAVLOV and MAT'Ē, *Pamyatniki iskusstva Drevnego Egipta* [etc.], pl. 53; MAT'Ē, *Iskusstvo Drevnego Egipta* (1961), fig. 200; FINGARET, *Iskusstvo Drevnego Egipta v sobranii Ermitazha*, fig. on p. 47; LANDA and LAPIS, *Egyptian Antiquities in the Hermitage*, pl. 44. Text, HELCK, *Urk.* iv. 2102–3 [807], cf. *Übersetz.* (1961), p. 398; STRUVE, *Etyudy po istorii Severnogo Prichernomor'ya, Kavkaza i Sredney Azii*, pp. 301 [29], cf. 282. See LIEBLEIN, *Die ägyptischen Denkmäler* [etc.] (1873), p. 27 [47]; GOLÉNISCHEFF, *Inventaire de la collection égyptienne* (1891), p. 151.

London, British Museum.

Stela, deceased before Rēc-Ḥarakhti, Thoth and Ma'et, and hymns below, No. 551, and panels, hymns, and deceased adoring below, Nos. 550, 552. *Hiero. Texts*, viii, pls. xxvii, xxviii, pp. 30–3; *Guide (Sculpture)*, pl. xix (stela), pp. 130–1 [461–3]; *Guide, Eg. Colln.* (1930), fig. 197 (stela), p. 358; HARI, *Horemheb*, figs. 26–7, pp. 89–96; texts, HELCK, *Urk.* iv. 2094–102 [805–6], cf. *Übersetz.* (1961), 395–8; see SHARPE, *Eg. antiq.* pp. 68–9. No. 551, BRUNNER, *Hieroglyphische Chrestomathie*, Taf. 18; text, MEYER in *Ä.Z.* xv (1877), pp. 149–51. Nos. 550, 552, SHARPE, *Eg. Inscr.* 2 Ser. 92; CURTO, *L'Egitto antico* (1961), Tav. 5, p. 84 [G, H].

Paris, Louvre.

Two registers (to the left of Brooklyn Mus. 32.103), II (lower part only), remains of perhaps bringing captives, III, foreigners acclaiming, B 56 [E.11273]. CAPART, *Documents*, ii, pl. 61; VANDIER in *Mélanges Syriens offerts à Monsieur René Dussaud*, ii, pl. i [left], pp. 811–16; HARI, op. cit. figs. 32, 35 [left], pl. xvii [left] (text), pp. 103, 105–9; CURTO, op. cit. Tav. 3 [left], p. 84 [C]; GIVEON, *Les Bédouins Shosou des documents égyptiens*, pl. iii, pp. 34–5 [Doc. 9]; ARCHIVES phot. E.254. III, WRZESZ., *Atlas*, ii. 3 [Beibild 4]; PIJOÁN, *Summa*

Artis, iii (1945), fig. 454; DESROCHES-NOBLECOURT, *L'Art ég.* fig. 64. Titles of deceased, PFLÜGER, *Haremhab und die Amarnazeit*, p. 16 [top]; HELCK, *Urk.* iv. 2088 [D], cf. *Übersetz.* (1961), p. 392. See BOREUX, *Guide*, i, p. 136; VANDIER, *Guide* (1948), pp. 17-18; (1952), p. 18; (1973), p. 28.

Vienna, Kunsthistorisches Museum.

Bowing courtiers, and text above, Inv.214 (adjoining Berlin (East) Mus. 22663 and Leyden Mus. Inv.H.III.QQQQ; a cast in Leyden is shown in many publications of the Leyden blocks). *Echnaton, Nofretete, Tutanchamun*. Ausstellung . . . Wien, 23. April . . . 29. Juni 1975, No. 99 with fig. Text, WIEDEMANN in *P.S.B.A.* xi (1889), p. 425; VON BERGMANN in *A.Z.* xxvii (1889), p. 126; WRZSZINSKI, *Aegyptische Inschriften aus dem K.K. Hofmuseum in Wien*, pp. 50-2 [i. 18]; with that of Berlin (East) Mus. 22663, GARDINER in *J.E.A.* 39 (1953), fig. 2, p. 7. See *Uebersicht* (1895), p. 37 [138]; (1923), pp. 12-13 [138].

Formerly in Zizinia Collection.

Upper part of deceased, and eleven columns of text. HARI, *Horemheb*, fig. 13, pl. xi, pp. 64-8. Text, WIEDEMANN in *P.S.B.A.* xi (1889), p. 424 [4]; HELCK, *Urk.* iv. 2087 [C], cf. *Übersetz.* (1961), p. 392 [C].

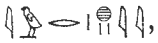

LS 25. IUROKHY , Real royal scribe beloved of him, General. Ramesside.

Column, deceased before four genii. Texts, L. *D. Text*, i, p. 182.

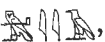
Zad-pillar, in Cairo Mus. JE 65061. GAUTHIER in *Ann. Serv.* xxxv (1935), pl. i, pp. 81-4.



LS 27. MAYA , Overseer of the Treasury, Fan-bearer on the right of the King, etc. Temp. Tut'ankhamūn to Haremhab.

Plan LXXVI.

Parents (probably), Iuy , Judge (from graffito in Roy. tb. 43, *Bibl.* i². 560(4)) and Weret , Songstress of Amūn. Wife, Meryt , Songstress of Amūn.

Complete, GRAEFE in *Mitt. Kairo*, 31 (1975), pp. 187-220, with Taf. 57-62 and figs. 1-8. L. *D. Text*, i, pp. 182-4, with sketch-plan. Plan and section, L. *D.* i, 42; reconstructed plan, GRAEFE in *Göttinger Miscellen*, No. 16 (1975), fig. 1 on p. 15, cf. pp. 9-14; some texts, HELCK, *Urk.* iv. 2163-6 [845] (some collated), cf. *Übersetz.* (1961), pp. 424-6. See HARI in *Orientalia*, n.s. 43 (1974), pp. 153-61.

Columned Hall.

(1) [1st ed. 1-4] Doorway. (a) and (b) Remains of four columns of text, and deceased with wife at bottom (deceased at (a), formerly in Amherst Colln., now in Rochester (New York), University Memorial Art Gallery, 42.55). (c) Deceased and wife, with brother Naḥuḥer  censuring, and remains of autobiographical text. (d) Registers, I, [deceased and wife seated], with man before them, II, brothers Naḥuḥer and Nakht as offering-bringers before Weret and Henutyunu  (probably another wife of Iuy).

(a) L. *D.* iii. 240 [b]. Block in Rochester, *Sotheby Sale Cat.* (AMHERST), June 13-17, 1921, pl. v [193], p. 19. (b) L. *D.* iii. 240 [c]. (c) Id. ib. 240 [a]. (d) Id. ib. 240 [d], *Text*, i, p. 183.

(2) [1st ed. 6] Hymn to the moon, and remains of two registers, I, people, II, relatives

and officials with offerings before [deceased and wife seated]. Block with upper part of brother Nahu(her) from II (in *Bibl.* i². 814), in Baltimore, Walters Art Gallery, 22.86.

Id. ib. 241 [b]. Baltimore block, STEINDORFF, *Cat.* pl. xlvi [266], p. 79.

(3) [1st ed. 5] Remains of hymn to the sun, and offering-bringers before deceased and wife seated, with man from another scene left of it (block with wife and man, in Cairo Mus. Temp. No. 19.6.24.1). Block with head of Nahuher, from farther left, in Hamburg, Museum für Kunst und Gewerbe, 1924.123.

L. D. iii. 241 [a], and adjoining block in Cairo, QUIBELL, *Saqqara (1908-1910)*, pl. lxxxii [1], p. 145. Hamburg block, HOFFMANN and HEWICKER, *Kunst des Altertums in Hamburg*, Taf. 5; Essen. *5000 Jahre*, No. 107 with Abb.

(4) and (5) [1st ed. 7, 8] Funeral procession scenes. (4) Men dragging standing and seated statues, followed by men with chests and jars and mourners, in Berlin (East) Mus. 2089 (now much damaged). Block with female mourners, probably from here, in Toronto Mus. 955.79.1. (5) Remaining registers, I, legs of men and animals, II, men in front of kiosks with offerings, III, men dragging coffin and kneeling statue. Register III is in Berlin (East) Mus. 2088 (now much damaged).

L. D. iii. 242 [a, b], with text of gap, *Text*, i, p. 183. Berlin (East) Mus. 2088-9, *Aeg. und Vorderasiat. Alterthümer*, Taf. 23; WRESZ., *Atlas*, i. 388; *Ausf. Verz.* Abb. 33a, b, pp. 153-4 (as No. 2089); men dragging statues, NEUBURGER, *The Technical Arts and Sciences of the Ancients*, fig. 274; texts, *Aeg. Inschr.* ii, pp. 185-6. (4) Berlin (East) Mus. 2089, man adorning seated statue and another pouring water, LANGE, *Äg. Kunst*, pl. 115; id. *Lebensbilder*, Abb. 51; statues and men between them, SÄVE-SÖDERBERGH, *Egyptisk Egenart*, fig. 32; hand of standing statue, SCHÄFER, *Von äg. Kunst (1922 and 1930)*, Taf. 38 [3]; (1963), Taf. 42 [2]; Eng. ed. *Principles of Egyptian Art*, pl. 69. Toronto Mus. 955.79.1, NEEDLER in *The Royal Ontario Museum. Bulletin of the Division of Art & Archaeology*, No. 26 (Dec. 1957), pl. 6, figs. 1, 2, pp. 10-16; id. in *The Connoisseur*, clxvi (1967), fig. 12, p. 149. (5) Text of 'those dragging bark' (i.e. sledge with coffin) between I and II, LÜDDECKENS in *Mitt. Kairo*, 11 (1943), pp. 145-6 [71].

(6) [1st ed. 9-11] Pilaster. (a) Mourner, (b) four columns of text (top missing), (c) two offering-bringers.

L. D. iii. 242 [c].

(7) Hathor-cow in shrine, and offerings, perhaps from here, in Cairo Mus. Temp. No. 29.6.24.13.

QUIBELL, *Saqqara (1908-10)*, pl. lxxxi [1].

(8) Remains of hymn to the sun, and name and titles, in Cairo Mus. Temp. No. 19.6.24.10.

Id. ib. pl. lxxiv [2], p. 144.

(9) Remains of registers, I, deceased and wife seated, with monkey under chair, three men censuring and bringing offerings, and deceased adoring Hathor-cow in bark, II-III, registration of Syrian captives and of humped cattle brought by herdsmen, before [deceased], in Cairo Mus. JE 43274.

Id. ib. pls. lxv, lxvi, lxviA, lxix [5], lxxxii [2], pp. 143, 144, 145; scribes, with some men and cattle, in II-III, FORMAN (W. and B.) and VILÍMKOVÁ, *Eg. Art*, pls. 101-2; scribe with cattle and one herdsman in III, WEIGALL, *Anc. Eg. . . . Art*, 240 [upper]; see MASPERO, *Guide*, p. 162 [554, 556].

(10) and (11) Pilaster fragments, probably from here. Offering-text, JE 43273; QUIBELL, op. cit. pls. lxx [4], lxxiv [5], p. 144. Hymn to the moon, JE 43272; id. ib. pl. lxx [6], p. 144. Offering-bringer; id. ib. pl. lxx [5], p. 144.

Column. Name and titles, L. D. iii. 241 [c].

Statues. Formerly Anastasi Colln., now in Leyden Museum.

Deceased and wife seated, double-statue, Inv. AST.3. BOESER, *Beschreibung*, v, Taf. vi [11]; LEEMANS, *Aeg. Mon.* ii, pl. vii [D. 35]; VAN WIJNGAARDEN, *Meesterwerken*, pl. 40; *Gids* (1926), fig. on p. 76; (1928), fig. on p. 83; (1937), fig. on p. 107; BREMMER, *Eg. kunst*, No. 41; BÉNÉDITE, *L'Art égyptien dans ses lignes générales*, pl. xxiv; WOLF, *Kunst*, Abb. 443, p. 467; *Chron. d'Ég.* xxvi (1951), fig. 25 [left], p. 324; DESROCHES-NOBLECOURT, *L'Art ég.* fig. 47; LANGE and HIRMER, *Aegypten. Architektur* (1957), pl. 206; (1967), pl. 212; HORNE-MANN, *Types*, v, pls. 1216–17; DAUMAS, *Civ. de l'Ég.* pl. 51; KLASENS, *Egyptische kunst*, pl. 27; *Artefact*, pl. 49, p. 36; HORNUNG, *Das Grab des Haremhab im Tal der Könige*, Abb. 2; GROENEWEGEN-FRANKFORT and ASHMOLE, *Art of the Ancient World*, fig. 80; SCHNEIDER in *Bull. Soc. fr. d'Ég.* No. 69 (March 1974), fig. on p. 31; VANDERSLEYEN, *Das Alte Ägypten*, Abb. 199. See LEEMANS, *Descr. rais.* p. 51 [D.35]; BOESER, *Cat.* (1907), p. 68 [83].

Deceased seated, Inv.AST.1. Id. *Beschreibung*, v, Taf. iv [12]; LEEMANS, *Aeg. Mon.* ii, pl. vii [D.34]; VAN WIJNGAARDEN, op. cit. pl. 41 [right]; BREMMER, op. cit. Nos. 37–8; *Chron. d'Ég.* xxvi (1951), fig. 25 [right], p. 324; LANGE and HIRMER, op. cit. (1957), pl. 207; (1967), pl. 213; STRÖMBOM, *Egyptens Konst*, fig. 138 (as Brit. Mus.); HORNEMANN, *Types*, iii, pl. 682; DESROCHES-NOBLECOURT, *Tutankhamen*, fig. 185. Upper part, KLASENS, op. cit. pl. 29; *Artefact*, pl. 51, p. 36; SCHNEIDER, op. cit. fig. on p. 27. Head, MÜLLER (H. W.) in *Münchner Jahrb.* 3 Ser. xviii (1967), Abb. 17 on p. 24, cf. p. 27. See LEEMANS, *Descr. rais.* p. 51 [D.34]; BOESER, *Cat.* (1907), p. 69 [85].

Wife seated, with *menat* of Hathor in left hand, Inv.AST.2. Id. *Beschreibung*, v, Taf. v [13]; LEEMANS, *Aeg. Mon.* ii, pl. xxi [D.124]; VAN WIJNGAARDEN, op. cit. pl. 41 [left]; BREMMER, op. cit. Nos. 39, 40; WOLF, *Kunst*, Abb. 444, p. 467; *Chron. d'Ég.* xxvi (1951), fig. 25 [middle], p. 324; KLASENS, op. cit. pl. 28; HORNEMANN, *Types*, iv, pl. 1069; HICKMANN, *45 Siècles*, pl. lxxxiii; id. *Ägypten*, Abb. 119; id. in *Cahiers d'Hist. Ég.* Ser. vi [5, 6] (1954), fig. 15, p. 281; *Gids* (1953), fig. 15; FORBES, *De textielindustrie van het oude Egypte in Rayon Revue*, vii [6] (1953), fig. on p. 266; POULSEN (V.), *Ägyptische Kunst. Neues Reich und Spätzeit*, pl. on p. 60; Amsterdam. 5000 jaar, fig. 25 [67]; YOYOTTE, *Treasures*, pl. on p. 134; *Artefact*, pl. 50, p. 36; SCHNEIDER, op. cit. fig. on p. 29. Upper part, LANGE and HIRMER, *Aegypten. Architektur* (1957), pls. 208–9; (1967), pl. 214; ATARASHI, *Egypt*, pl. 57; DESROCHES-NOBLECOURT, *L'Art ég.* fig. 46; id. *Ancient Egypt* [etc.], pl. 7; GROENEWEGEN-FRANKFORT and ASHMOLE, *Art of the Ancient World*, fig. 81. See LEEMANS, *Descr. rais.* p. 59 [D.124]; BOESER, *Cat.* (1907), p. 68 [84].

Other finds.

Cubit-measure, wood, in Louvre, N.1538. LEPSIUS, *Die alt-ägyptische Elle und ihre Eintheilung* (repr. from *Abhandlungen der Königl. Akademie der Wissenschaften zu Berlin*, 1865), Taf. ii [a], pp. 14 [2], 17–18 [12], 19; SHARPE, *Eg. Inscr.* 2 Ser. 46 [upper]; SKINNER in SINGER [etc.], *A History of Technology*, i, fig. 566 [lower], p. 775; SEYFFARTH MSS. iv. 3903; ARCHIVES phot. E.1156, B. Text, PIERRET in *P.S.B.A.* xvii (1895), pp. 208–9; HELCK, *Urk.* iv. 2169–70 [848], cf. *Übersetz.* (1961), p. 427. Names of divinities, LEPSIUS, *Über den ersten Ägyptischen Götterkreis* [etc.] in *Abhandlungen der Berliner Akademie der Wissenschaften*, 1851, Taf. i [v] after p. 214.

LS 28. RA CIA , Overseer of the royal apartments of the harim at Memphis, etc. Dyn. XIX.

Father, Pay , Overseer of the royal apartments of the King's wife, etc.

L. D. Text, i, p. 184; DE MEULENAERE in *Chron. d'Ég.* 1 (1975), p. 88 [c, e].

Stelae, in Berlin (East) Mus. (a) No. 7271; L. D. iii. 242 [d]; text, *Aeg. Inschr.* ii, pp. 194, 195; name and titles, LIEBLEIN, *Dict.* No. 911; see *Ausf. Verz.* p. 166. (b) No. 7270; text, L. D. Text, i, p. 184; *Aeg. Inschr.* ii, pp. 192-3; see *Ausf. Verz.* pp. 165-6.

Pyramidion of deceased and father, in Vienna Mus. Inv. 5908. Texts, VON BERGMANN in *Rec. Trav.* ix (1887), p. 50 [26]; see *Uebersicht* (1895), p. 39 [xviii]; (1923), p. 14 [xviii].

LS 29. HARMIN , Overseer of the royal apartments of the harîm at Memphis, Real royal scribe beloved of him, etc. Temp. Sethos I.

Wife, May  Songstress of Isis, etc.

Name and title from inner door, L. D. Text, i, p. 185.

Stelae.

Formerly in Passalacqua Colln., now in Berlin (East) Museum. (a) No. 7274; deceased holding *ba* on arm, from middle register, MEKHITARIAN, *L'Égypte*, fig. on p. 45; ŽABKAR, *A Study of the Ba Concept in Ancient Egyptian Texts*, pl. 4; *menat* held by wife, SACHS, *Die Musikinstrumente des alten Ägyptens*, Abb. 35, p. 38 (as 4272); texts, *Aeg. Inschr.* ii, pp. 153-6; KITCHEN, *Ram. Inschr.* i. 310-11 [125,2]; names, LIEBLEIN, *Dict.* No. 738 [1st item]; see PASSALACQUA, *Cat. raisonné*, pp. 45-6 [1362]; *Ausf. Verz.* p. 164. (b) No. 7305; deceased and wife, from upper register, SACHS, op. cit. Abb. 31 on p. 33; texts, *Aeg. Inschr.* ii, pp. 136-9; omitting that at bottom, KITCHEN, op. cit. 311-12 [125,3]; names, LIEBLEIN, *Dict.* No. 744; see PASSALACQUA, op. cit. pp. 46-7 [1363]; *Ausf. Verz.* p. 164.

'Stèle des Colliers', deceased being decorated with collars before Sethos I, in Louvre, C 213 [E.3337]. PIERRET, *Rec. inscr.* ii, p. 10; BOREUX, *Guide*, i, pl. viii, p. 80; GABRA, *Les conseils de fonctionnaires* [etc.], pl. ii, pp. 41-4; *Encycl. phot. Louvre*, pls. 90-1; *L'Égypte. Art et civilisation. Sér. 4 bis* (1951), pl. 10; LECA, *Médecine*, fig. 30; DEVÉRIA squeezezes, 6196, 33-4 and Gal. Nat. Londres, 11; ARCHIVES phot. E.81; omitting some text, WRESZ., *Atlas*, ii 148a [Beibild i]; CHARBONNEAUX, *Les Merveilles du Louvre*, i, pl. on p. 99; HÖLSCHER (U.), *The Excavation of Medinet Habu*, iii, fig. 19, p. 41; POSENER, SAUNERON and YOYOTTE, *Dict. civ.* fig. on p. 221 [lower]. Sethos I, DESROCHES, *L'Art égyptien au Musée du Louvre* (1941), fig. on 20th p. [right]; BOREUX, *Sculpture*, pl. xxxiv; head, MYŚLIWIEC, *Le Portrait royal dans le bas-relief du Nouvel Empire*, pl. xcvi [215]. Text, KITCHEN, op. cit. 309 [125,1]. See DE ROUGÉ, *Notice des monuments* (1883), pp. 158-60; VANDIER, *Guide* (1948 and 1952), p. 17; (1973), p. 27.

Blocks.

Bologna, Museo Civico.

Registers, I, remains of text and offerings, II, Anubis followed by deceased before Osiris-Onnophris in weighing scene, with Thoth as baboon recording, and seated gods above, No. 1944. GABALLA, *The Memphite Tomb-Chapel of Mose*, pl. xl; GARDINER MSS. photo. 28.416. Texts, KITCHEN, op. cit. 312-23 [125,4]. See KMINER-SZEDLO, *Catalogo di Antichità Egizie*, pp. 212-13 (some texts); DUCATI, *Guida*, pp. 48-9 [C]; CURTO, *L'Egitto antico* (1961), p. 106 [140].

Cairo Museum.

See MASPERO, *Guide*, pp. 163-4 [559], 179 [650]; some, GABRA, *Les conseils de fonctionnaires* [etc.], pp. 44-5. Head, from one of these, MYŚLIWIEC, op. cit. pl. lxxxii [187].

Registers, **I** (from right), deceased in bark with *benu*-bird, spearing serpent, and reciting spell against donkeys and crocodiles, and statues and mummy in purification and Opening-the-Mouth scenes, **II**, men bringing funeral outfit, female mourners, and coffin carried, **III**, men in kiosks with offerings, JE 8374. MARIETTE, *Mon. div.* pl. 60; WERBROUCK, *Pleureuses*, pl. xxxv, pp. 81-2; MASPERO, *Égypte*, fig. 372. Man about to break pot, in **III**, BORCHARDT in *Ä.Z.* 64 (1929), Abb. 3, p. 14. Texts, KITCHEN, op. cit. 315-16 [125,6A]; some in **I**, DE ROUGÉ, *Inscr. hiéro.* pl. xxxix [top]; **II** and **III**, LÜDDECKENS in *Mitt. Kairo*, 11 (1943), pp. 128-31 [60-2] (partly collated), cf. Abb. 47-9. Some names and titles, LIEBLEIN, *Dict.* No. 968.

Lower part of deceased at table, with wife squatting by chair, and three offering-bringers below, JE 8375.

Registers, **I**, deceased adores Duamutf and Kēbḥsenuf, **II**, deceased and wife before Ḥaḥor in sycamore, JE 8376 (formerly in Huber Colln.). **II** (reversed), REINISCH, *Miramar*, fig. 29 on p. 238; Ḥaḥor, UNGER, *Botanische Streifzüge auf dem Gebiete der Culturgeschichte in Sitzungsberichte der kaiserlichen Akademie der Wissenschaften, Wien, Mathematisch-naturwissenschaftliche Classe*, xxxviii (1859), Taf. ix, p. 138. Texts, KITCHEN, op. cit. 317 [125,6B].

Registers, **I**, Osiris seated, **II**, deceased kneeling adores Imset and Ḥepy, JE 8377. Texts, id. ib. 317 [125,6C].

Deceased kneeling adoring, JE 8378. Head, MYŚLIWIEC, op. cit. pl. xcvi [216]. Text, KITCHEN, op. cit. 318 [125,6D].

Osiris seated, JE 8379.

Offering-bringers, JE 8380. Texts, id. ib. 318 [125,6E]; part, GABRA, *Les conseils de fonctionnaires* [etc.], p. 45.

Deceased seated, with wife by chair, JE 8380 bis. Text, KITCHEN, op. cit. 318 [125,6F].

Registers, **I**, kneeling offering-bringers, **II**, man before [deceased at] table, JE 8380 ter. Texts, id. ib. 319 [125,6G]; of **II**, DE ROUGÉ, *Inscr. hiéro.* pl. xxxix [middle].

Jamb-fragment, with adjoining scenes of couple(?) and offering-bringers, JE 8381. Texts, KITCHEN, op. cit. 319 [125,6H].

Deceased adores Ptaḥ and Sekhmet, JE 8382. Texts, id. ib. 319 [125,6I].

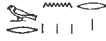
Tree-goddess scene, with woman Wernuro , Temp. No. 1.7.24.6. Texts, id. ib. 319 [125,6J].

PARAḤOTP (or RAḤOTP)  [⊙] _⊙ [!], Governor of the town, Vizier, etc. Temp. Ramesses II.



South-west of the Monastery of Apa Jeremias.

Stela, in Cairo Mus. JE 48845. VASSALLI MSS. 24, 24A, 25 [upper]; main text, and text of one side, BRUGSCH, *Thes.* 950-1 [16]; and of the other side, PIEHL, *Inscr. hiéro.* 3 Sér. lxxxi-lxxxii[Q].

Statue, kneeling, headless, holding naos of Ptaḥ, granite. ALTENMÜLLER and MOUSSA in *Mitt. Kairo*, 30 (1974), Taf. 1, pp. 1-9. See LECLANT in *Orientalia*, n.s. 25 (1956), p. 256 [14, B, a]; LAUER in *Bull. Soc. fr. d'Ég.* No. 22 (Nov. 1956), pp. 62-3.

Canopic-jars. (a) Ḥepy, Brit. Mus. 36531 (formerly Anastasi Colln.); text, WILLIAMS rubbings, iv. 107 [middle left]; name and title, SETHE, *Zur Geschichte der Einbalsamierung* [etc.] in *Sitzungsb. Berlin* (1934), p. 7* [X, B]. (b) Kēbḥsenuf, Brussels, Mus. Roy. E.5901 (formerly Anastasi Colln.); text, SPELEERS, *Rec. inscr.* p. 80 [299]; WILBOUR MSS. 13, 7; see LENORMANT, *Cat. . . . d'antiquités égyptiennes . . . Anastasi*, Vente, rue de Clichy, Paris,

June 23-7, 1857, No. 236; DE MEULENAERE in *Bull. Mus. Roy.* 4 Sér. 37 (1965), p. 5; id. in *Chron. d'Ég.* xli (1966), pp. 223-4.



H 9. MERYTYNEIT  (altered to MERYTYATEN ) Steward of the Temple of the Aten. Temp. Amenophis IV.

Exact position unknown.

Block, two men in Opening-the-Mouth ceremony, in Berlin (East) Mus. 2070. SCHÄFER, *Kunstwerke aus El-Amarna*, ii, Taf. 13; id. *Amarna in Religion und Kunst*, Taf. 6; SEYFFARTH MSS. iii. 2650-6, No. 3; text, WIEDEMANN in *P.S.B.A.* xvii (1895), p. 154; *Aeg. Inschr.* ii, p. 121; see *Auf. Verz.* p. 130; OTTO, *Das ägyptische Mundöffnungsritual*, ii, p. 182 [85]; LÖHR in *Studien zur altägyptischen Kultur*, 2 (1975), pp. 172-3 [Dok. III 2a], cf. Taf. vi [1] (from SCHÄFER).

Three blocks, including one with [deceased] and wife seated. MARIETTE, *Mastabas*, figs. on p. 449; two, WILKINSON MSS. xviii. 42 [lower left].

TENRY  Overseer of works on all monuments of the King, Royal scribe, etc. Temp. Ramesses II.

Father, Paser  Judge, Steward of Amün. Wife, Nashaty  (from stela Brit. Mus. 165, see *infra*).

Exact position unknown.

Incomplete wall inscribed on two faces, in Cairo Mus CG 34516. (a) Two registers, I (mostly lost), text and feet of man on left, II, Ptaḥ on right and deceased on left, with two rows of cartouches ("Table of Kings") between them. (b) On central block, stela, at top, deceased adoring Rē-Ḥarakhti, and Nakht , Overseer of the royal apartments of the King's wife, etc., adoring Osiris, with hymn below.

(a) MARIETTE, *Mon. div.* pl. 58, p. 19; DE ROUGÉ, *Album photo.* pls. 143-5; WILDUNG, *Die Rolle äg. Könige*, Abb. i (I incomplete), pp. 34-5 [Dok. viii. 30]; GARDINER MSS. photo. 28.459 (with additional block in I); DEVÉRIA squeezes, 6165, i.10. II, MARIETTE in *Rev. Arch.* n.s. x (1864), pl. xvii, pp. 169-86, and separately same year; DE ROUGÉ, *Recherches sur les monuments* [etc.] (1866), pl. i, p. 148 (repr. in *Bibl. Ég.* xxvi, pl. i, p. 143); MEYER, *Ägyptische Chronologie* (repr. from *Abhandlungen der Königl. Preuss. Akademie der Wissenschaften*, 1904), Taf. i [lower], pp. 104-5. See MARIETTE in *Rev. Arch.* n.s. ii (1860), pp. 20-3, and separately same year; MASPERO, *Guide* (1883), pp. 432, 433-7; (1915), pp. 180-1 [660].

(b) MARIETTE, *Mon. div.* pl. 57 [b], pp. 18-19; DEVÉRIA squeezes, 6170A, 6, 14. See MASPERO, *Guide* (1883), pp. 432-3.

Stela-fragment with text of Book of the Dead, in Cairo Mus. JE 18924 (probably). Text, PIEHL, *Inscr. hiéro.* 1 Sér. lxxvii-lxxviii [B].

Lower part of statue of deceased kneeling with naos of Osiris, sandstone, in Cairo Mus. CG 1105. Text, BORCHARDT, *Statuen*, iv, pp. 58-9.

Four canopic-jars, alabaster, formerly in Duc de Gênes and Marquise de Casati Collections, now in Brooklyn Mus. 48.30.1-4. No. 48.30.2, FAZZINI, *Images for Eternity*, Cat. No. 79; *Ägyptische Kunst aus dem Brooklyn Museum* (Berlin, Ägyptisches Museum, 4. Sept.-31. Okt. 1976), No. 55; *Égypte Éternelle. Chefs-d'œuvre du Brooklyn Museum* (Palais des

Beaux-Arts, Bruxelles, 9 décembre 1976–20 février 1977), No. 55; lid, *Eg. Art . . . Brooklyn*, figs. 49.

NEW KINGDOM FINDS

Re-used in Monastery of Apa Jeremias unless otherwise stated



Statues.

Ptaḥmosi , Royal scribe of the Treasury, Overseer of the cattle of Amūn, etc., fragment of block-statue, Dyn. XIX, found south of the Pyramid of Unis, in Cairo Mus. CG 642. Texts, BORCHARDT, *Statuen*, ii, p. 188.

Head of block-statue, Dyn. XIX or later, found south of the Pyramid of Unis, in Cairo Mus. CG 850. Text, id. ib. iii, p. 121.

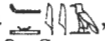
Stelae.

Huya , end of Dyn. XVIII, found south of the Pyramid of Unis, in Cairo Mus. JE 27958. SUZUKI, *Sculpture of the World*, iii, *Egypt*, on pl. 103. Deceased adoring, MYŚLIWIEC, *Le Portrait royal dans le bas-relief du Nouvel Empire*, pl. lxxxv [195]. See *Bull. Inst. Ég.* ii Sér. 8 (1887), Annexe xxxi (after p. 368).

Iny , Overseer of gold-workers of the Lord of the Two Lands, Knower of secrets in the Mansion of Gold, etc., lower part with offering-text of deceased and wife Wiay , late Dyn. XVIII or early Dyn. XIX, found south of the Step Pyramid, in Cairo Mus. JE 15115. GABALLA in *J.E.A.* 63 (1977), pls. xxiii [2], xxiiiA [2], pp. 125–6; MARIETTE, *Mastabas*, fig. on p. 450 [H 8]; text, id. *Mon. div.* pl. 62 [b]; names and titles, DE ROUGÉ, *Inscr. hiéro.* pls. lv [middle upper], ccci [2].

Iry , Scribe of the Temple of Userma'et-rē'-setepenrē' in the domain of Amūn, temp. Ramesses II or later, found north of LS 27. Name and title, L. D. *Text*, i, p. 182, cf. position, L. D. i. 33 [LS 26].

[Ra'ḥmosi] before deified king Teti , fragment, Dyn. XIX, in Cairo Mus. JE 40693. GRDSELOFF in *Ann. Serv.* xxxix (1939), fig. 17, pp. 393–6 (as Ity); WILDUNG, *Die Rolle äg. Könige*, i, Taf. viii [2], pp. 97–9 [Dok. xvii. 70] (as Sekhemkhet).

Sety , Sword-bearer [in front of] the Lord of the Two Lands, Armour-bearer of the company 'Ruler in the Two Lands', Dyn. XIX. QUIBELL, *Saqqara (1907–8)*, pl. xxxviii [1, 2], pp. 107–8.

Blocks.

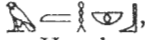

Text from scene with geographical procession, basalt, temp. Ramesses II, from Temple of Ptaḥ at Mīt Rahīna (see *infra*). Id. ib. (1908–10), pl. lxxxvi [4], p. 147 (as granite); see LECLANT in *Orientalia*, n.s. 23 (1954), p. 70 [f].



Ḥaremḥab , Royal scribe, Fan-bearer on the right of the King, Steward, temp. Ramesses II or later. Blocks, in Cairo Mus., deceased and wife offering and censng to Osiris and two goddesses on right, with Min and a goddess on left, and another block with text, JE 43276 and Temp. No. 17.6.24.5, QUIBELL, op. cit. (1908–10), pls. lxvii [2], lxxii [1], lxxiii [7], pp. 143, 144; man and wife kneeling before Ḥathor-cow, Temp. No. 14.6.24.25, id. ib. pl. lxxx [1], p. 145; upper part of priest censng before deceased at table, Temp. Nos. 19.6.24.15–17, id. ib. pls. lxxviii [1], lxxiii [2], lxxiv [9], pp. 143, 144; two registers, I, remains of divinities, II, deceased before seated couple, Temp. No. 19.6.24.18, id. ib. pl. lxxv [10], p. 144; deceased adoring *zad*-pillar, with hymn to the sun above, JE 43277 (with another block),

id. ib. pls. lxxvii [3], lxxiii [1], pp. 143, 144; head of god and text, Temp. Nos. 19.6.24.4-5, id. ib. pls. lxxiii [6], lxxxi [7], pp. 144, 145; fragments of texts, Temp. Nos. 19.6.24.11, 13, id. ib. pl. lxxiii [3, 4], p. 144. Other blocks, including men bringing animals, deceased and wife Ty $\text{𓄏} \text{𓄏} \text{𓄏}$ before two gods, judgement scene, and fragment of text, id. ib. pls. lxxi (head of wife on 4 = Cairo JE 43276), lxxii [2], lxxiii [5, 8], p. 144.



Kairi $\text{𓄏} \text{𓄏} \text{𓄏} \text{𓄏}$, Head of chariot-makers, Overseer of a workshop in the armoury, etc., Dyn. XIX. Two *zad*-pillars, in Cairo Mus. JE 43270, QUIBELL, *Saqqara (1908-10)*, pl. lxxviii, p. 145; see GAUTHIER in *Ann. Serv.* xxxv (1935), pp. 95-6. Blocks, in Cairo Mus. JE 43275 (see MASPERO, *Guide*, p. 162 [555]). (a)¹ Registers, I, remains of two people at table, II, oxen, female mourners, offering-bringers, and man in front of kiosk breaking jars, QUIBELL, *Saqqara (1908-10)*, pls. lxxvii [1], lxxx [4], p. 143; oxen and mourners in II, FORMAN (W. and B.) and VILÍMKOVÁ, *Eg. Art*, pl. 84; mourners, WERBROUCK, *Pleureuses*, fig. 49, p. 83; man with jars, BORCHARDT in *Ä.Z.* 64 (1929), Abb. 2, p. 14 with note 7; (b) three registers of armourers and others at work, QUIBELL, op. cit. pls. lxxviii [4], lxxv [5], pp. 144, 145; GRIFFITH INST. photo. 360 [lower]; block on right, WRESZ., *Atlas*, i. 416; (c) two adjoining blocks, men bringing weapons, chariots, etc., QUIBELL, op. cit. pl. lxxv [3, 7], p. 145; (d) two registers, I, Osiris seated with a goddess standing behind, and man from another scene on right, II, priest censuring shrine (with coffin); left part, id. ib. pls. lxxviii [6], lxxv [8], pp. 144, 145; (e) and (f) two incomplete registers, (e) I, priest before man and wife, II, man before deceased and wife at table, id. ib. pls. lxxviii [5], lxxv [6], pp. 144, 145; adjoining (f) I, helmets and bundles of arrows, with man on right, II, chariots, and deceased on right, id. ib. pls. lxxviii [3], lxxv [2], pp. 143, 145; (g) man weighing helmets, id. ib. pl. lxxv [4], p. 145; (h) fragment of offering-list, id. ib. pl. lxxvii [3], p. 145; (i) sacred cows, and Sons of Horus, id. ib. pl. lxxvii [4-6]. Other blocks, in Cairo Museum, (a) two faces, (α) deceased purified, followed by [wife] Iyemia $\text{𓄏} \text{𓄏} \text{𓄏} \text{𓄏}$, (β) upper part of man and wife, Temp. No. 1.7.24.8, id. ib. pls. lxxviii [2], lxxv [1], and lxix [1], lxxvi [1], pp. 144, 145; (b) man seated before offerings, Temp. No. 1.7.24.9, id. ib. pl. lxxvi [2], p. 145; (c) two faces, (α) woman kneeling, (β) deceased and wife kneeling before tree-goddess, Temp. No. 1.7.24.10, id. ib. pls. lxix [3, 4], lxxvi [5, 7], pp. 144, 145; (d) mourners, and priests censuring and purifying [mummy], Temp. No. 17.6.24.9, id. ib. pl. lxxvi [6], p. 145; (e) registers, I, lower part of man standing at table, II, remains of text, Temp. No. 19.6.24.7, id. ib. pl. lxxvii [7], p. 145; (f) two priests between Osiris and Anubis with mummy, Temp. No. 17.6.24.4, id. ib. pl. lxxix [1], p. 145; (g) two faces, (α) daughter under chair, and text of deceased, (β) Ptaḥemḥab $\text{𓄏} \text{𓄏} \text{𓄏} \text{𓄏}$ and wife Roy $\text{𓄏} \text{𓄏}$ seated, Temp. No. 1.7.24.2, id. ib. pls. lxxvi [3], lxxx [2], p. 145; (h) remains of two columns of text of deceased, Temp. No. 17.6.24.7, id. ib. pl. lxxvi [8]; (i) deceased ploughing in Fields of Offerings, Temp. No. 17.6.24.8, id. ib. pl. lxxvi [9], p. 145; (j) woman before offerings, Temp. No. 17.6.24.10, id. ib. pl. lxxix [3], p. 145; GARDINER MSS. photo. 28.460; incomplete, FORMAN (W. and B.) and VILÍMKOVÁ, op. cit. pl. 60; SÉE, *Naissance*, fig. on p. 191 [upper]; LANGE (K.), *Ägyptische Bildnisse*, fig. on p. 5; (k) lower part of man and wife, and two offering-bringers below, JE 43277 (with another block), QUIBELL, op. cit. pl. lxxvii [8], p. 145; (l) lower part of seated man, with weapons, etc., before and behind him, id. ib. pl. lxxv [10]; (m) upper part of daughter by chair of [deceased], Temp. No. 25.6.24.2, id. ib. pl. lxxvi [4]. Other blocks, including daughter of deceased under chair with cat and monkey, tomb, deceased before Osiris, seated statues and double-statues of divinities, all probably in Cairo Museum, id. ib. pls. lxix [2] and lxxvi [11], lxxv [9, 11], lxxvi [10], lxxvii [1, 2, 9], pp. 143, 144, 145.

¹ This and following letters are *not* the same as those inscribed on the blocks in Cairo Museum.

Harmosi , Steward of the Lord of the Two Lands, and wife Tamyt , Songstress of Amūn, Dyn. XIX. Text of [purification scene], id. ib. pl. lxxxii [7], p. 145.

Hatiy , Dyn. XIX. Upper part of [deceased] and wife Meryptah , and text, in Cairo Mus. Temp. No. 25.6.24.1, id. ib. pl. lxxiv [1], p. 144.

Ptahemḥab and Amenemḥab, both Heads of goldworkers, Dyn. XIX. Two blocks from jambs, with tree-goddess, etc., also showing Raḥmosi, Head of custodians of the cabin, in Cairo Mus. JE 46190-1; texts, CHÂBAN in *Ann. Serv.* xvii (1917), pp. 180-2 [15, 14].

Raḥmosi , Scribe of recruits of the Lord of the Two Lands, Deputy of the temple, Dyn. XIX. Hathor and wife(?) Tawah , QUIBELL, *Saqqara* (1907-8), pl. li [4], p. 112.

Penrennut , Chief of police, Ramesside. Upper part of deceased, id. ib. (1908-10), pl. lxxxii [2], p. 145.

Blocks, Dyn. XIX, in Cairo Mus. [Man] and woman with sistrum squatting, Temp. No. 19.6.24.14, id. ib. pl. lxxiv [8]. Lower part of scene showing man playing flute before statue(?), and another adoring, Temp. No. 14.6.24.24, id. ib. pl. lxxx [3]; HICKMANN, *Ägypten*, Abb. 19; id. in *Orientalische Musik*, Taf. ii [3]. Pyramidal tomb with two columns, Temp. No. 19.6.24.3, QUIBELL, op. cit. pl. lxxx [10]. Bark with shrine, Temp. No. 5.7.24.4, id. ib. pl. lxxxii [10]. A Greatest of the directors of craftsmen at [table], Temp. No. 5.7.24.1, id. ib. pl. lxxxii [13]. Bottom part of scene with man before gods, JE 43275 (with other blocks), id. ib. pl. lxxx [11]. Men bringing animals, Temp. No. 17.6.24.1, id. ib. pl. lxxx [6]. Courtiers with fans, id. ib. pl. lxxxii [8]. Upper part of man, id. ib. pl. lxxxii [12].

Representations of seated double-statues of a divinity and Ramesses II, HABACHI in *A.Z.* 97 (1971), Taf. vii, figs. 4, 5, pp. 70-1; texts, KITCHEN, *Ram. Inscr.* ii. 428-31 [157, C, 1st to 3rd blocks].

Various, QUIBELL, op. cit. pls. lxxiv [3] and lxxix [4], lxxiv [4, 6, 7], lxxix [2, 5], lxxx [5, 7-9], lxxxii [3-6, 9, 11], lxxxvi [3] (called 2 in error on p. 147), pp. 144, 145, 147.

(c) LATE PERIOD

ESDHOUT , Overseer of royal scribes of the army of Upper and Lower Egypt, etc. Temp. Psammetikhos I.

Map LXII.

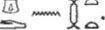
Parents, Pedeamūn  and Degenneit(?) .

QUIBELL, *Saqqara* (1908-10), pp. 30-3, with plan, pl. lix [1], p. 142, and views, pls. lix [2], lx [1, 4], p. 142.

Chapel.

Jamb with remains of text, id. ib. pl. lx [3], p. 142.

Blocks. Deceased, and texts from Book of the Dead, id. ib. pls. lxii [2, 4, 5], lxiii, pp. 33, 143. Remains of marsh-scene, including papyrus harvest, and block with dogs and animals in desert (latter in Cairo Mus. Temp. No. 17.6.24.11), id. ib. pl. lxii [1], p. 143; Cairo block, GRIFFITH INST. photo. 360 [upper right]; see MASPERO, *Guide*, p. 162 [556A]. Block with antelope and man, in Cairo Mus. Temp. No. 17.6.24.2, QUIBELL, op. cit. pl. lxii [3], p. 143.

Two fragments of Apis-statue with human body, id. ib. pl. lx [2], pp. 33, 142.

Burial chamber.

Rectangular sarcophagus, with figure of deceased, jackals and hawks in high relief on lid,



in Cairo Mus. CG 29312. MASPERO and GAUTHIER, *Sarcophages*, ii, pls. xviii, xix, pp. 60-6; *in situ*, QUIBELL, op. cit. pl. lx [5], pp. 32, 142. See *Descr. somm.* No. 1350.

Female statuette, found in shaft. QUIBELL, op. cit. pl. lxi [1], pp. 33 [1], 142.

TOMB OF THE PSAMMETHEKS AND KHEDEBNEIT-YERBONI [II].

Map LXII.

Plan and section, BURTON MSS. 25618, 28, 29 verso, 30.

East part. Two men Psammethek □ || . A. Chief steward, Overseer of the seal, Overseer of scribes of the royal repast, etc., son of Mertneit  (mother). B. Overseer of scribes of the royal repast, son of Meramün-tabes  (mother). Both probably temp. Amasis.

See CORTEGGIANI in *B.I.F.A.O.* 73 (1973), p. 153 with notes 2-6.

Psammethek [A].

Pyramid-texts on walls of burial chamber, DARESSY in *Rec. Trav.* xvii (1895), pp. 17-24 (as west of the Pyramid of Unis). Determinative of title *wr ꜥꜣw*, GRDSELOFF in *Ann. Serv.* xlii (1943), fig. 20, p. 116 note 2.

Offering-table, basalt, in Cairo Mus. CG 23114. KAMAL, *Tables d'offrandes (Cat. Caire)*, pl. xxvii, p. 94; MARIETTE, *Mon. div.* pl. 95 [a], p. 29. Name and titles, BRUGSCH, *Thes.* 1458 [94]. See MASPERO, *Guide*, p. 207 [854].

Canopic-jars, alabaster, according to Mariette from Abydos (*Bibl.* v. 74) but most probably from here. Three, in Cairo Mus. CG 4308-10; names and title, MARIETTE, *Catalogue général des monuments d'Abydos* [etc.], No. 1457; REISNER, *Canopics*, pp. 209-10; see id. in *Ä.Z.* xxxvii (1899), p. 70 [top]. One, in Alexandria, Graeco-Roman Mus.; see BOTTI, *Notice des monuments* [etc.] (1893), p. 10 [716].

Statues, Osiris seated, Isis seated, and deceased protected by Hathor-cow, all inscribed, greywacke, in Cairo Mus. CG 38358, 38884, 784. MARIETTE, *Mon. div.* pls. 96, 77 [1]; id. *Album du Musée de Boulaq* (1872), pl. 10; MASPERO, *Hist. anc.* i, fig. on pp. 88, 131-2; id. *Égypte*, figs. 470-2; id. *Guide* (1914), figs. 58-60, pp. 200-3 [855-7]; (1915), figs. 70-2, pp. 208-10 [855-7]; EBERS, *Aegypten*, ii, figs. on p. 61; Eng. ed. figs. on p. 54; WEIGALL, *Anc. Eg. . . . Art*, 330-1; SCHÄFER and ANDRAE, *Kunst* (1925), 419; (1930), 435; (1942), 440; MURRAY, *Sculpture*, pl. xlv [1-3]; CAROTTI, *L'Arte*, fig. 301; GRIFFITH INST. photos. 354-5, 355A (SEBAH, 123). CG 38358, DARESSY, *Statues*, pl. xix, pp. 96-7; MORET, *Rois et dieux d'Égypte*, pl. ix [1]; COOK in HAMMERTON, *Universal History of the World*, i, fig. on p. 645 [middle]; SHORTER, *The Egyptian Gods*, pl. iii; PIJOAN, *History of Art*, i, fig. 134; *Encycl. phot. Caire*, pl. 176; HARRIS, *Egyptian Art*, pl. 53 [b]; ČERNÝ in *Historia de las Religiones*, i (1955), 1st pl. after p. 172; DONADONI, *Egyptian Museum Cairo*, pl. on p. 151. CG 38884, DARESSY, *Statues*, pl. xlv, p. 221; MORET, op. cit. pl. ix [2]; COOK, op. cit. fig. on p. 645 [left]; *The Cambridge Ancient History. Plates*, i (1927), pl. on p. 31 [d]; PIJOAN, op. cit. fig. 135; HARRIS, op. cit. pl. 53 [a]; head, BOTHMER, *Eg. Sculp.* pl. 52 [128], p. 64. CG 784, BORCHARDT, *Statuen*, iii, Bl. 144, pp. 91-2; MASPERO, *L'Arch. ég.* (1887), fig. 199; (1907), fig. 219; id. *Eg. Art*, pls. facing pp. 116, 118, cf. pp. 116-17; id. *Essais*, figs. 39, 40, pp. 134-8; VON BISSING, *Denkmäler*, ii, Taf. 73A, 73B; BOSSE, *Die menschliche Figur*, Taf. x [184], p. 69; *Encycl. phot. Caire*, pls. 174-5; MITRY, *Illus. Cat.* No. 857; LUGN, *Konst*, fig. 81; ROSS, *The Art of Egypt*, pl. on p. 231 [3]; PIJOAN, *Summa Artis*, iii (1945), figs. 627-8;

RANKE, *Meisterwerke*, Abb. 61; DE MONTGON, *L'Égypte*, fig. on p. 51; FRANKFORT, *Ancient Egyptian Religion*, pl. 12; BENDOW, *Forfallets Egypt*, pl. facing p. 112; HORNEMANN, *Types*, v, pl. 1345; PIRENNE, *Hist. civ.* iii, pl. 43 after p. 172; ČERNÝ, op. cit. 4th pl. after p. 196; DE RACHEWILTZ, *L'Arte*, Tav. 34; *Great Museums*, pl. 102; DONADONI, *Egyptian Museum Cairo*, pl. on p. 152; TERRACE and FISCHER, *Treasures*, pp. 165-8 with pls.; front part, DESROCHES-NOBLECOURT, *L'Art ég.* fig. 86; *L'Égypte. Art et Civilisation*, Série 57 (1951), pl. 1 [lower]; LANGE, *Äg. Kunst*, pl. 127; heads, id. *Ägyptische Tierplastik*, Abb. 34; MÜLLER, *Äg. Kunst*, Abb. 174; CLARK (K.), *Animals and Men*, pl. 14; name and titles, BRUGSCH, *Thes.* 1458 [95].

Psammethk [B].

Sarcophagus, anthropoid, basalt, in Cairo Mus. JE 34649. Text, DARESSY in *Rec. Trav.* xvii (1895), pp. 24-5. See BUHL, *Sarcophagi*, p. 32 [C, a2], cf. pl. ii (titles).

Canopic-jars, alabaster, according to Mariette from Abydos (*Bibl.* v. 74) but most probably from here, in Cairo Mus. CG 4126-9. REISNER, *Canopics*, pl. xviii, pp. 88-92; text of CG 4126, MARIETTE, *Catalogue général des monuments d'Abydos* [etc.], No. 1458.

West part. Khedebneit-yerboni [II] , King's daughter, King's wife. Dyn. XXVI.

Canopic-jars, alabaster, in Cairo Mus. CG 4089-92. REISNER in *Ä.Z.* xxxvii (1899), fig. 10, p. 69 [26]; texts, MARIETTE, *Mon. div.* pl. 95 [c-f]; name and titles, LIEBLEIN, *Dict.* No. 1296 [2nd item]; see REISNER, *Canopics*, pp. 55-8 (texts of CG 4089-91); VITTMANN in *Chron. d'Ég.* xlix (1974), pp. 44 [5], 47-50.

LATE PERIOD FINDS

Architrave of Achoris, re-used. QUIBELL, *Saqqara (1908-10)*, pl. lxxxv, p. 146.

Blocks of Nektanebos I. (a) Id. ib. pl. lxxxvi [5], p. 147; (b) pl. lxxxii [8], p. 145; (c) id. ib. (1907-8), p. 4.

Various, Late Period. Id. ib. (1908-10), pl. lxxxii [3-6], p. 145.

H. AROUND PYRAMIDS OF PEPEY I, MERENRĒ' I,
AND ISESI

Positions of tombs, MASPERO, *Trois années de fouilles* [etc.] in *Mém. Miss.* i, pl. facing p. 200.

Head-rest of Amenemōpet, wood, Dyn. XIX, from Mortuary Temple of Pepy I. See LAUER in *Comptes rendus* (1970), p. 493; id. in *Bull. Soc. fr. d'Ég.* No. 62 (Oct. 1971), p. 44; LECLANT in *Orientalia*, n.s. 40 (1971), p. 233, cf. pl. xxxiv [29].



WEST OF PYRAMID OF PEPEY I





IP I , Chief of the estate, Royal chamberlain. Dyn. VI.

Map LXVII [1].

Wife, Senbet , King's adorer.

Tomb wall, in Cairo Mus. CG 1536-7. Five scenes (from left), 1, deceased seated with family, 2, registers, I-III, harvest, IV, butchers, 3, deceased in palanquin, with men with sunshades and attendants, 4, three registers of boats, 5, registers (lost except for bottom one) of offering-bringers before [deceased] and wife.

BORCHARDT, *Denkmäler*, i, Bl. 50, pp. 237-42. 1-3, WRESZ., *Atlas*, i, 405-6; VON BISSING, *Denkmäler*, i, Taf. 18, and *Text* to Taf. 18 [fig.]. 1, and left end of 2, SMITH, *Hist. Eg. Sculp.* pl. 56 [b], pp. 208, 222; daughter 'Ankhespepy  ♀  behind deceased, VON BISSING in *Ä.Z.* xxxvii (1899), fig. on p. 76 [upper], cf. pp. 75-6. 3, MASPERO, *Guide* (1908), fig. 5, p. 29 [38]; (1914), fig. 6, pp. 29-30 [61]; (1915), fig. 9, pp. 30-1 [61]; id. *Hist. anc.* i, fig. on p. 298, cf. p. 298 note 2; PIRENNE, *Hist. civ.* i, pl. 93 facing p. 296; MICHALOWSKI, *Art*, fig. 261; deceased, BAKER, *Furniture*, fig. 49; text of men carrying palanquin, ERMAN in *Ä.Z.* xxxviii (1900), pp. 64-5; id. *Reden, Rufe und Lieder*, p. 52. 3, and boats in I and left part of II of 4, CAPART, *Memphis*, figs. 171-3. 4, omitting part of II, WRESZ., *Atlas*, iii, 111; boat in I, MASPERO, *Hist. anc.* i, fig. on p. 393; JÉQUIER in *B.I.F.A.O.* ix (1911), pl. iii [2], p. 69 note 1; CLARKE and ENGELBACH, *Ancient Egyptian Masonry*, fig. 45; boat in left part of II, WESSETZKY in *Archaeologiai Értesítő*, 91 (1964), fig. 3 on p. 64; boats in I and III, LANDSTRÖM, *Ships of the Pharaohs*, figs. 139, 143-4. Names and titles, LIEBLEIN, *Dict.* No. 1399; name, WILBOUR MSS. 2 G. 65 [middle].

Tombs of IBI , Dyn. VI (destroyed), HENENI , Tenant of the Pyramid of Isesi(?), etc., Dyn. VI, and tomb re-used by MENTUHOTP , Overseer of goldworkers, etc., and 'ANKHNEBEF , Count, etc., Dyn. XI or XII.

Map LXVII [1].

Names and titles, MASPERO, *Trois années de fouilles* [etc.] in *Mém. Miss.* i, p. 208.

EAST AND NORTH-EAST OF PYRAMID OF ISESI

PEPY'ANKH SETHU. End of Dyn. VI.

East of the Pyramid. Position not marked on map.

Description, mentioning false-door and reserve-head found in débris in shaft, FAKHRY, *Sneferu*, i, p. 30; LECLANT in *Orientalia*, n.s. 23 (1954), p. 69 [top]. View, showing painted vases, granaries, etc., on walls of burial chamber, id. ib. pl. xii [7].

Offering-table of 'Isesi', found nearby. See FAKHRY, op. cit. p. 30.

S'ANKHENPTAH , Director of the washing of hands, Director of the *m_{skt}t* and *m_{ndt}* barks. Dyn. VI.

Map LXVII [1].

Offering-list and texts, on three walls. MASPERO, *Trois années de fouilles* [etc.] in *Mém. Miss.* i, pp. 205-7 [9].

BETWEEN PYRAMIDS OF MERENRĒ' I AND ISESI

MASTABA OF DYN. XII.



Map LXVII [1].

MASPERO, *Trois années de fouilles* [etc.] in *Mém. Miss.* i, pp. 208-10.

East chamber.

Rectangular wooden coffin of Kheperkarē , in Cairo Mus. CG 28036. LACAU, *Sarcophages*, i, pl. xiii, pp. 101-7; texts, MASPERO, op. cit. pp. 231-7 [3]; DE BUCK, *Coffin Texts*, iv, vii [Sq2C]; name and title, LIEBLEIN, *Dict.* No. 2015 [2nd item].

West chamber.

Rectangular wooden coffins of Situbastet  (woman) and Hor , in Cairo Mus. CG 28034-5. Texts, MASPERO, op. cit. pp. 218-31 [2], 210-18 [1]; LACAU, op. cit. pp. 88-100; DE BUCK, op. cit. ii, iv-vii [Sq1C] and iv, v [Sq7C].

Model boats, in Cairo Mus. See MASPERO, op. cit. p. 209; id. *Guide*, p. 310 [3120-2].

IHY , Judge in the Six Great Courts, Supervisor of prophets of the Pyramid of Merenrē, etc. Temp. Merenrē I or later.

Position not marked on map.

Offering-texts, offering-list, and names of offerings, on walls of burial chamber, MASPERO, *Trois années de fouilles* [etc.] in *Mém. Miss.* i, pp. 201-4 [7] (as near the tomb of Hēneni).

NEFERKHU , Lector-priest, Regulator of a phyle. Dyn. VI.

Position not marked on map.

Offering-texts and names of offerings on walls of burial chamber, MASPERO, *Trois années de fouilles* [etc.] in *Mém. Miss.* i, pp. 204-5 [8].

NORTH-WEST OF PYRAMID OF MERENRĒ I

DESHRI , Chief of the estate, etc. 1st Int. Period.

Map LXVII [1].

Walls and ceiling-blocks of burial chamber, with offering-texts, granaries, offerings, and offering-list, in Cairo Mus. CG 1572. BORCHARDT, *Denkmäler*, ii, Bl. 72-4 bis, pp. 45-51; name and titles, LIEBLEIN, *Dict.* No. 2015 [1st item]; offering-list, HASSAN, *Giza*, vi [2], pls. cxv-cxxii [126], p. 147; names of some offerings, MASPERO, *Trois années de fouilles* [etc.] in *Mém. Miss.* i, p. 201 [4]; see id. *Guide*, p. 29 [48].

SHEMAI , 1st Int. Period (?).

Map LXVII [1].

Unfinished. Name, MASPERO, *Trois années de fouilles* [etc.] in *Mém. Miss.* i, p. 201 [5].

NEBU  (also NEBI), Overseer of tenants of the Great House, etc. Temp. Merenrē I or later.

Map LXVII [1].

Wife, Sebutet , Tenant of the Pyramid of Merenrē I, etc.

Texts on stela-fragments, and offering-text and names of offerings from burial chamber, MASPERO, *Trois années de fouilles* [etc.] in *Mém. Miss.* i, pp. 199-200 [2]; names and titles, LIEBLEIN, *Dict.* No. 1405.

Right side of door, in Cairo Mus. CG 1525; texts, BORCHARDT, *Denkmäler*, i, pp. 225-6.
Side wall of niche of wife, CG 1687; texts, id. ib. ii, p. 135.

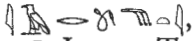
IARTI , *wab*-priest of the two hundred of the Pyramid of Merenrē^c I, etc. Temp. Merenrē^c I or later.

Map LXVII [1].

Wife, Merti , King's sole adorer, etc.
Some texts, WILBOUR MSS. 2 G, 66 [middle, 4].

Chapel. Objects in Cairo Museum.

Lintel with deceased (twice), wife and [son Merenrē^c-sonb], Lector-priest, and facing them, Khnenti , with text concerning his appointment as *ka*-servant, CG 1634. BORCHARDT, *Denkmäler*, ii, Bl. 85, pp. 101-2; GRDSELOFF in *Ann. Serv.* xlii (1943), figs. 1, 2, pp. 26-37; GOEDICKE, *Rechtsinschriften*, Taf. vii, pp. 178-81; GRDSELOFF MSS. 1.38 (photo).

Offering-table and false-door, probably of wife, CG 1355, 1523. Texts, BORCHARDT, op. cit. i, pp. 25, 224. *Hwt*-sign on CG 1523, see FISCHER in *J.A.O.S.* 76 (1956), p. 101 with note 7.

Burial chamber.

Offering-texts and names of offerings, MASPERO, *Trois années de fouilles* [etc.] in *Mém. Miss.* i, pp. 200-1 [3].

BITI , King's sole adorer, Prophetess of Ḥathor. Dyn. VI.

Map LXVII [1].

Name and titles, MASPERO, *Trois années de fouilles* [etc.] in *Mém. Miss.* i, p. 199 [1].

FINDS FROM NEAR PYRAMIDS OF PEPY I AND MERENRĒ^c I

Fragment of false-door with representation of table with offerings and remains of text with cartouches of Isesi and Snefru, Dyn. V-VI, found in débris of Pyramid of Pepy I, in Berlin Mus. 1143. *L. D.* ii. 152 [e], *Text*, i, p. 197 (as No. 1153); text, *Aeg. Inschr.* i, p. 41; see *Ausf. Verz.* p. 61.

False-door and offering-table of Ameny-wahib, Middle Kingdom, found east of Pyramid of Merenrē^c I. LAUER in *Comptes rendus* (1973), pl. viii, p. 331; LECLANT in *Orientalia*, n.s. 43 (1974), pl. xxi [31], pp. 184-5 [γ].

I. AROUND PYRAMIDS OF IBI AND PEPY II, AND MAṢTABET FARA'ÛN

Map LXVII [2]

AROUND PYRAMID OF IBI

ITI  KHENTKAUS , King's sole adorer, Prophetess of Ḥathor, etc. End of Dyn. VI.



West of the Pyramid. Position not marked on map.

JÉQUIER, *La Pyramide d'Abu*, pp. 22-4.

Burial chamber.

Doorway. Offering-text and names and titles on lintel and jambs, id. ib. p. 23 [upper].
Walls. Offering-texts and names of offerings, id. ib. pp. 23 [lower]-24.

Ramesside stelae. Many fragmentary. Re-used north-west of the Pyramid.



Amenmosi  (perhaps also called Ra(ḥ)mosi), Scribe of the Treasury of the Lord of the Two Lands, etc., and wife Buy . JÉQUIER, *La Pyramide d'Aba*, pl. xviii [3], p. 27.



Huy  and wife Mutnefert. Id. ib. pl. xxii [17], p. 32.

Khons . Head of servants, and wife Sekhmet. Id. ib. pl. xx [13], pp. 30-1.

Maia  and wife Rē. Id. ib. pl. xviii [2], pp. 26-7.

Penyunu . Royal scribe of the Lord [of the Two Lands]. Id. ib. pl. xx [12], p. 30.

Pewah . son of Yunut , both Bearers (i.e. Chisellers) of Amūn, and Hēnut, in Neuchâtel Mus. Eg.409, id. ib. pl. xvii [1], pp. 25-6; see GABUS, *175 ans*, Pt. 1, p. 54 [paroi nord, 3rd item]. Stela of Yunut, dedicated by Pewah, JÉQUIER, op. cit. pl. xxii [19], p. 32.



Sety . Scribe of accounts of the cattle of Amūn, son of Tusu , Armour-bearer of the Lord of the Two Lands, and Takhar , in Cairo Mus. JE 54155. Id. ib. pl. xvii [10], p. 29; id. *Douze ans*, fig. 46; id. in *Ann. Serv.* xxx (1930), pl. v, p. 115; *Le Règne du Soleil. Akhnaton et Néfertiti*. Exposition . . . Bruxelles, 17 janvier-16 mars 1975, No. 71 with figs.; *Echnaton, Nofretete, Tutanchamun*. Ausstellung . . . Wien, 23. April . . . 29. Juni 1975, No. 71 with figs.; *Solens rike. Akhnaton, Nefertiti, Tut-ank-Amon*. Utställingen . . . Oslo, 16. juli-16. september 1975, No. 71 with pl. 68; *Echnaton och Nefertiti*. Utställning . . . Stockholm, 16 oktober . . . 7 december 1975, No. 71 with pl. 68; *Nofretete, Echnaton*. Ausstellung . . . München, 17. Januar-21. März 1976, No. 71; *Nofretete, Echnaton*. Ausstellung . . . Berlin, 10. April-16. Juni 1976, No. 71; *Echnaton, Nofretete, Tutanchamun*. Ausstellung . . . Hildesheim, 15. Juli-26. September 1976, No. 71; *Akhnaton og Nefertiti in Louisiana Revy*, 17 [1] (Oct. 1976), fig. on p. 35 [71]; FATON in *Archéologia*, No. 80 (March 1975), fig. on p. 64 [left].



Man (name lost) and wife Takhar . JÉQUIER, *La Pyramide d'Aba*, pl. xix [4], pp. 27-8.

Names lost. Id. ib. pls. xix [5, 6], xxi [11, 14, 15], xxii [9, 16], pp. 28, 29-30, 31-32.



AROUND PYRAMID-ENCLOSURE OF NEIT

Fragments of false-doors of Merynemti , Overseer, of Upper Egypt, and of the *gs-pr*, etc., and Nemtiemsaf , [King's eldest son] of his body (probably later King Merenrē Nemtiemsaf II). JÉQUIER, *Les Pyramides des reines Neit et Apouit*, fig. 32, p. 55.

Fragments of false-doors of women Itit  and 'Ankhnepespy , Prophetess of Hāthor, etc., architrave of Thetety , Overseer of tenants of the Great House, with sons offering, and offering-table of Nakhty, Scribe of the royal documents, etc., all Dyn. VI. Id. ib. fig. 33, p. 56.

Offering-tables of Nefery, Chief of the estate, Khai , and woman Nesit , Dyn. VI. Names, id. ib. p. 56.

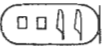
IN AND AROUND PYRAMID-ENCLOSURE OF IPUT II

‘ANKHNESPEPY  , King's wife (of Pepy II), King's mother (of Neferkarē of Dyn. VII or VIII), etc.

In west magazine of the Mortuary Temple.

Sarcophagus, with names of Pepy I, granite, with basalt lid, in Cairo Mus. JE 65908. JÉQUIER, *Les Pyramides des reines Neit et Apouit*, pl. xl, fig. 30, pp. 51-4; DONADONI ROVERI, *Sarcofagi egizi*, Tav. xxxv, pp. 144-5 [B 84]; see JÉQUIER in *Ann. Serv.* xxxii (1932), p. 48; id. *Douze ans*, p. 95.





Fragments of false-door. Id. *Les Pyramides des reines Neit et Apouit*, fig. 31, p. 52; see id. *Douze ans*, pp. 95-6.



NEBRĒ , God's father of Ptah, First prophet of Thoth, etc. Late Period.

North of the Pyramid. Position not marked on map.

JÉQUIER, *Les Pyramides des reines Neit et Apouit*, pp. 59-60 (name and titles from coffins). Four alabaster canopic-jars. Texts, id. ib. on fig. 37, p. 60.

VARIOUS FINDS. Dyn. VI to 1st Int. Period

Fragments of false-doors of Hesi , Iaty  (woman), Idi , Lector-priest, Iti, Lector-priest, Senti , Shekert  (woman), and Sheshi. JÉQUIER, *Les Pyramides des reines Neit et Apouit*, fig. 34.

Offering-tables (some fragmentary) of Mereruka, Rediu , Count of the Great House, etc. (two), Seni, King's sole adorer, etc., Teti'ankh, Lector-priest, etc., Zadi , Lector-priest. Id. ib. fig. 35.

Architrave with four figures of Perti , Prophetess of Hathor Mistress of the Two Banks of Horus, etc. Id. ib. fig. 36.

NORTH-EAST OF PYRAMID OF PEPY II

Map LXVII [2]

N.I. End of Dyn. VI.

JÉQUIER, *Tombeaux de particuliers*, pp. 85-9, with plan, fig. 96.



Lintel, false-door, and offering-table of Isti , King's sole adorer, Prophetess of Hathor, etc. Id. ib. fig. 98, p. 89.

Re-used monuments. End of Dyn. VI.

False-door of Iri , Id. ib. fig. 97 [upper right], p. 86.

Block with upper part of Bau , Sole companion. Id. ib. fig. 97 [lower left], p. 86.

Block with titles of a Regulator of a phyle of the Pyramid of Pepy I (probably), etc. Id. ib. fig. 97 [upper left], p. 86.

Offering-table of Ipi, Count, etc., mentioning Sethy , Treasurer of the King of Lower Egypt, and Zefates , Prophetess of Hathor, etc. Id. ib. fig. 97 [lower right], p. 86 with note 3.

N.II. End of Dyn. VI.

JÉQUIER, *Tombeaux de particuliers*, pp. 89-93, with plan, fig. 99.

Ointment-slab of Henut $\text{𓆎} \text{𓆏}$, King's sole adorer (woman), alabaster, in Cairo Mus. JE 50674. Id. ib. fig. 102, p. 21.

Vase-lid with names of Pepy I, in Cairo Mus. JE 50675. Id. ib. fig. 103 [right], p. 91.

False-door of Nesti $\text{𓆎} \text{𓆏}$. Id. ib. fig. 104, p. 93.

N.III. End of Dyn. VI.

JÉQUIER, *Tombeaux de particuliers*, pp. 93-4, with plan, fig. 105.

Fragmentary false-door of Harhotp $\text{𓆎} \text{𓆏}$, and jamb of Iti $\text{𓆎} \text{𓆏}$, Lector-priest, etc., found nearby. Id. ib. figs. 107-8, p. 94.

N.IV. End of Dyn. VI.

JÉQUIER, *Tombeaux de particuliers*, pp. 94-107, with plans, figs. 109-10, 113.

Chapel I.

Lower part of false-door of Henenu $\text{𓆎} \text{𓆏}$, Chief of the estate, Lector-priest, etc., with deceased seated and offering-bringers on side-walls of niche. Id. ib. figs. 111-12; name, WILBOUR MSS. 2 G, 65 [top].

Chapel II.

Plan, MASPERO, *Trois années de fouilles* [etc.] in *Mém. Miss.* i, fig. on p. 192. Names and titles, LIEBLEIN, *Dict.* No. 1398.

Lower part of false-door of Biu $\text{𓆎} \text{𓆏}$, Royal chamberlain, Scribe of the royal documents in the presence, etc., with remains of deceased at table and offering-bringers on side-walls of niche. JÉQUIER, *op. cit.* figs. 114-15; texts, including some not seen by Jéquier, MASPERO, *op. cit.* pp. 192-3 [A-E].

Block with upper part of deceased, probably from here, in Chicago, Or. Inst. 10814.

Remains of false-door (now lost) and right side-wall of niche of Pepi $\text{𓆎} \text{𓆏}$, Chief of the estate, Royal chamberlain, Lector-priest, with deceased and remains of threat on jamb, and deceased at table and offering-bringers on thickness. Texts, id. ib. pp. 193-4 [F-I]. Side-wall, JÉQUIER, *op. cit.* fig. 116; texts, WILBOUR MSS. 2 G, 61 [lower]; threat, SETHE, *Urk.* i. 262 [19 (159), C].

Burial chamber of Biu. Usurped from Akhi $\text{𓆎} \text{𓆏}$, Royal chamberlain.

Doorway, with offering-text on lintel and titles on jambs, JÉQUIER, *op. cit.* p. 102. Walls with offering-texts, offering-list, granaries, and offerings, id. ib. pl. xii, fig. 117.

Sarcophagus. Texts, id. ib. p. 103.

Wooden statuette, in Neuchâtel Mus. Eg.401. Id. ib. pl. xiii [upper right], p. 104.

Burial chamber of Pepi.

Doorway, with offering-texts on lintel and titles on jambs, id. ib. fig. 118. Walls with offering-texts, offering-list, granaries, and offerings, id. ib. pl. xiv.

Sarcophagus. Texts, id. ib. p. 105 [top].

Inscribed head-rest, alabaster, in Cairo Mus. JE 52545. Id. ib. pl. xiii [upper middle], p. 105 [middle].

Wooden statuette, arms and legs missing, in Neuchâtel Mus. Eg.402. Id. ib. pl. xiii [upper left], p. 105.

Found nearby.

Fragments of false-door of Nebi Nebipu-pepy , Overseer, (a) of tenants of the Pyramid of Pepy I, (b) of prophets of Ḥaṭḥor Mistress of Nidua-snefru, etc. Id. ib. fig. 119, p. 107.

N.V. SHENACY , Chief Justice and Vizier, Overseer of Upper Egypt, etc. Temp. Pepy II.

JÉQUIER, *Tombeaux de particuliers*, pp. 107-9, with plan, fig. 120.

Chapel.

Relief-fragments with offering-bringers, estates, etc. Id. ib. fig. 122.

Jamb-fragment of Idi , Vizier, from another tomb. Name, id. ib. p. 109.

Wooden statuette, in Neuchâtel Mus. Eg.403. Id. ib. pl. xiii [lower left], p. 109.

Burial chamber.





Fragment of decoration showing offerings. Id. ib. fig. 121.

Found nearby.

Coffin of Ptaḥuser , King's *warb*-priest, Middle Kingdom (planks now in Neuchâtel Mus. Eg.336-7). Name, id. ib. p. 117 [top].

N.VI. End of Dyn. VI.

Id. ib. pp. 109-17.

Dersenez , Neferkarē-ankh , *warb*-priest of the two hundred of the Pyramid of Pepy II, Overlord of linen (*drt*), etc. (a) Upper part of deceased at table, with offering-list above, and blocks with names and titles, all from niche; id. ib. figs. 124-5, pp. 110-11. (b) Offering-table, perhaps of same man, with Ibebi , Overseer of the Two Cool Chambers of the Great House, and Rekhti , King's adorer (woman); id. ib. fig. 130 [top left], pp. 114-15.

Ḥatkaus , (woman). Offering-table, id. ib. fig. 130 [top right], p. 115.

Ḥebai , Overseer of linen (*sšrw*), Inspector of *ka*-servants. False-door ('stèle-maison'), in Louvre, E.14185, id. ib. fig. 128, p. 113; id. *Douze ans*, fig. 27; ARCHIVES phot. E.1051; see VANDIER, *Guide* (1952), p. 11; (1973), p. 17.

Nisuḥen , Overseer of linen (*sšrw*). Offering-table, JÉQUIER, *Tombeaux de particuliers*, fig. 130 [bottom left].

Irut , King's adorer (woman). Offering-table, id. ib. fig. 130 [middle right].

Khnemḥotp, Lector-priest, etc., relief-fragment. Id. ib. fig. 126, p. 112.

Khredni , Inspector of prophets, Greatest of the Five, etc. (a) Blocks, deceased at table, with man libating, and four registers of offering-bringers below, upper part in Neuchâtel Mus. Eg.427; id. ib. pl. xv [left, and bottom], pp. 111-12; Neuchâtel Mus. Eg.427, see GABUS, *175 ans*, Pt. 1, p. 54 [paroi est]. (b) Obelisk, JÉQUIER, *Tombeaux de particuliers*, fig. 132, p. 116.

Maru , Count. Obelisk, in Hamm, Städtisches Gustav Lübke-Museum, Inv. 5769; id. ib. fig. 131, p. 116; MARTIN (K.), *Ein Garantsymbol des Lebens*, p. 224 [15] with Abb. 5 on p. 235.



Nezui(?)  Scribe of a phyle. Offering-table, JÉQUIER, op. cit. fig. 130 [bottom right], p. 116 [top].

Uzat-khnementi(?)  Offering-table, id. ib. fig. 130 [middle left].

Weneni  Chief of the estate, etc. (father of Khredni, see above). 'Stèle-maison', id. ib. fig. 129, pp. 113-14.

Remains of offering-list of an Inspector . . . of the Pyramid of Pepy II, etc. Id. ib. fig. 127, p. 112.



Bust of male statuette. Id. ib. pl. xv [middle right], p. 116.

N.VII. DEGEM  MERYPEPY  Overseer of tenants of the Great House, etc. End of Dyn. VI.

Id. ib. pp. 117-20, with plan and section, figs. 133 [lower], 135.

False-door. Id. ib. fig. 134, pp. 117-18.

Walls of burial chamber with offering-texts, offering-list, granaries, and offerings. Id. ib. pl. xvi, fig. 136, pp. 119-20.

N.VIII. RA^cHERKA  IPI  Overseer of tenants of the Great House, etc. End of Dyn. VI.

Id. ib. pp. 121-5, with plan, fig. 133 [upper].

False-door. Id. ib. fig. 138, p. 122; id. *Douze ans*, fig. 34.

Burial chamber.

Lintel of doorway with offering-text, and jambs with titles, id. *Tombeaux de particuliers*, fig. 139, p. 122. Offering-text, granaries, and offerings, on walls, id. ib. fig. 140, p. 123 [top].

Wooden rectangular coffin, usurped from Imapepy  Ima, Lector-priest, etc., in Cairo Mus. JE 52012. Id. ib. pl. xvii, pp. 123, 125.

Seated statuette, fragmentary, name lost, in Neuchâtel Mus. Eg.399. Id. ib. pl. xiii [lower middle], p. 125.

Wooden statuette, incomplete, in Neuchâtel Mus. Eg.400. Id. ib. pl. xiii [lower right], p. 125.

N.IX. HARSHEF-SHEMA . . .  King's eldest son, etc. End of Dyn. VI.

North of the Pyramid. Position not marked on map.

JÉQUIER in *Ann. Serv.* xxxv (1935), pp. 132-4, with plan, figs. 1, cf. 2; DITTMANN in *Mitt. Kairo*, 6 (1936), p. 163 [middle].

Name and titles from fragments of lintel, false-door, and offering-table. JÉQUIER, op. cit. p. 134 [top].

N.X. 'ANKHNEBEF  *warb*-priest of the two hundred, etc. End of Dyn. VI.

North of the Pyramid. Position not marked on map.

JÉQUIER in *Ann. Serv.* xxxv (1935), pp. 134-6, with plan, fig. 3.

Burial chamber.

Doorway. Offering-text and titles on lintel and jambs, id. ib. p. 134 [bottom].

Walls. Offering-texts, offering-list, texts of granaries and names of offerings, id. ib. fig. 4 and pp. 135-6.

N.XI. NEFERKARĒC-NAKHT  KHETUI  HETEP, Overseer of tenants of the Great House, etc. End of Dyn. VI or 1st Int. Period.

About 300 metres east of last tomb. Position not marked on map.

JÉQUIER in *Ann. Serv.* xxxv (1935), pp. 34 [bottom], 136-40.

Walls of burial chamber. Offering-texts, offering-list, granaries, and names of offerings, id. ib. figs. 5, 7, cf. 6, pp. 137-40.

EAST OF PYRAMID OF PEPY II

Map LXVII [2]

M.II. End of Dyn. VI or 1st Int. Period.

JÉQUIER, *Tombeaux de particuliers*, pp. 8-9, with plan and section, fig. 5.

Wooden statuette, in Cairo Mus. JE 49119. Id. ib. pl. i [upper], p. 9 with note 1 (as JE 49110).

M.III. IDI  TEPEMKAU , Overseer of the department of the Great House, Overseer of the Two Cool Chambers of the Great House, etc, End of Dyn. VI.

JÉQUIER, *Tombeaux de particuliers*, pp. 9-21, with plan and sections, figs. 6 [lower], 8, 9; id. in *Ann. Serv.* xxvi (1926), pp. 56-8.

Burial chamber.

Sarcophagus, decorated inside. West side, and texts of east side, id. *Tombeaux* [etc.], fig. 11, p. 14; west side, id. in *Ann. Serv.* xxvi (1926), fig. 2, p. 57.

Side-room.

Blocks with offering-list, offerings and granaries, perhaps from original decoration of burial chamber, re-used. Id. *Tombeaux* [etc.], figs. 12-19, pp. 16-20.

Subsidiary burial chambers.

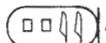
(a) Niḥesed-pepy  Chief of the estate, etc. Coffin-fragment with name and titles, id. ib. fig. 20 [upper], pp. 22, cf. 21.

(b) Idi, Lector-priest. Offering-text from lid of wooden rectangular coffin, id. ib. pp. 23 [top], cf. 22.

M.IV. WASHIPTAH , Overseer of the Two Cool Chambers of the Great House, etc. End of Dyn. VI.

JÉQUIER, *Tombeaux de particuliers*, pp. 23-7, with plan and sections, figs. 6 [upper], 23; id. in *Ann. Serv.* xxvi (1926), pp. 58, 60-1.

Fragment of false-door of 'Ankhnepespy , Prophetess of Hathor, Dyn. VI, re-used. Id. *Tombeaux* [etc.], fig. 22, p. 24.

Burial chamber.

Doorway. Offering-text on lintel, id. ib. p. 25 [top].

Coffin-fragment, wood. Title, id. ib. p. 25 [near bottom].

Dish-fragment with name of Pepy II, alabaster, in Cairo Mus. JE 49857. Id. ib. fig. 24 [top], p. 26.

Pottery jar-fragment with name of contents. Text, id. ib. fig. 24 [bottom], p. 26.

Subsidiary burial chamber. Heneni , Overseer of the Two Cool Chambers of the Great House, etc.

Offering-texts on lintel, jamb and walls, id. ib. p. 28.

M.VI. End of Dyn. VI or 1st Int. Period.



JÉQUIER, *Tombeaux de particuliers*, pp. 32-40, with plan and section, figs. 33-4.

Court.

False-door of Nesti, fragmentary. Id. ib. fig. 36, pp. 34-5.

Jamb of Nesti, fragmentary, original position unknown. Id. ib. fig. 37, p. 35.

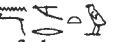
Burial chambers.

(a) Nesmerut  Nesti , Prophetess of Hathor, King's sole adorer. Lintel and jambs of doorway with offering-texts, id. ib. fig. 38, p. 35. Walls with offerings, id. ib. figs. 39, 40, p. 35.

(b) Seni , Hereditary prince, Overseer of the expedition, etc. (usurped from a Chief of the estate, etc.). Lintel and jambs of doorway with offering-texts and titles, id. ib. fig. 41, p. 35. Walls with offering-texts, offering-list, granaries, and offerings, id. ib. pl. iii, figs. 42-4, pp. 35-8.

M.VII. End of Dyn. VI.

JÉQUIER, *Tombeaux de particuliers*, pp. 40-54, with plan, fig. 45.



Burial chambers.

(a) Penu , Chief of the estate, Royal chamberlain, etc. Lintel and jambs of doorway with offering-texts and titles, id. ib. fig. 46, p. 44. Walls with offering-texts, offering-list, granaries, and offerings, id. ib. figs. 47-51, pp. 45-6. Texts on sarcophagus, id. ib. pp. 46 [bottom]-47.



(b) Senti , King's sole adorer, Noblewoman of the King. Lintel and jambs of doorway with offering-text and titles, id. ib. pl. iv, fig. 52, p. 47; id. *Douze ans*, fig. 29. Walls with offering-texts, offering-list, and offerings, id. *Tombeaux* [etc.], figs. 53-5, p. 48.

(c) Nekhut , Chief of the estate, Lector-priest, etc. Offering-texts on wooden coffin, id. ib. p. 52.

(d) Nekhut, Overseer of the *gs-pr*, Lector-priest, etc. Titles painted on lintel of doorway, id. ib. p. 54 [top].

(e) Neb(i)pu-pepy  Seni , Chief of the estate, Lector-priest. Doorway; jambs with titles and thicknesses with offerings, id. ib. fig. 57, p. 54.

Found nearby.

Offering-tables of Imapepy , Chief of the estate, etc., and , Overseer of linen (*sšrw*). Id. ib. figs. 59, 60, p. 54 [bottom].

M.IX. SHEY , Chief of the estate, Overseer of the *gs-pr*, etc. End of Dyn. VI.

JÉQUIER, *Tombeaux de particuliers*, pp. 58–62, with plan, fig. 67.

Burial chamber.

Doorway. Lintel and jambs with offering-texts and titles, id. ib. fig. 68, p. 58.

Ceiling. Titles, id. ib. p. 60.

Walls with offering-texts, offering-list, granaries, and offerings, id. ib. pls. v, vi, fig. 69, pp. 60–1; id. in *Ann. Serv.* xxvii (1927), pl. i, p. 53; id. *Douze ans*, fig. 30; Ross, *The Art of Egypt*, pl. on p. 98 [3].

M.X (west part). PTAḤANKHU  ITI , Chief of the estate, Overseer of the *gs-pr*, etc. End of Dyn. VI.

JÉQUIER, *Tombeaux de particuliers*, pp. 62–6, with plan, figs. 71, cf. 73.

Burial chamber.

Offering-text on lintel of doorway, id. ib. p. 64. Walls with offering-texts, granaries, and offerings, id. ib. pl. vii, pp. 64–5.

M.XI. MEḤI , Overseer of the *gs-pr*, etc. End of Dyn. VI.

JÉQUIER, *Tombeaux de particuliers*, pp. 67–76, with plans, figs. 75–6.

Wooden statuettes, in Cairo Mus. Naked man, JE 52564, id. ib. pl. viii [left and right], p. 67 with note 4. Man, JE 52565, id. ib. pl. viii [middle upper], p. 69 with note 1.

Burial chamber.

Lintel and jambs of doorway with offering-text and titles, id. ib. fig. 80, p. 70. Walls with offering-texts, offering-list, granaries, and offerings, id. ib. pls. ix, x, figs. 81–3, pp. 70–1.

Sarcophagus. Texts, id. ib. pp. 71, 75 [top].

Mummy-mask, cartonnage, in Cairo Mus. JE 52538. Id. ib. pl. viii [middle lower], p. 75 with note 1.

Subsidiary burial chambers.



(a) Neit , Prophetess of Ḥathor, etc. Texts of wooden coffin, id. ib. p. 75 [bottom].

(b) Shemait , Prophetess of Ḥathor, etc. Lintel and jambs of doorway with offering-text, id. ib. fig. 85, p. 76. Walls with offering-texts, offering-list, granaries and offerings, id. ib. pl. xi, p. 76. Name and titles from remains of wooden canopic-box, id. ib. p. 76 [middle].

Lintel of Antef , presumably Middle Kingdom, intrusive. Name, id. ib. p. 76 [top].

M.XII. End of Dyn. VI or 1st Int. Period.

JÉQUIER, *Tombeaux de particuliers*, pp. 77–84, with plan, fig. 86.

Obelisk-fragment of Memi , Hereditary prince, etc., and base of wooden statuette of Ithy , Chief of the estate, etc. Names, id. ib. p. 78.

Burial chambers.

(a) Sebaḳu [I] , Companion. Name on jambs of doorway, id. ib. p. 79 [top]. Walls with offering-list and granaries, id. ib. figs. 87-8, p. 79.

(b) Sebaḳu [II], Steward, etc. Remains of name on jambs of doorway, id. ib. p. 80 [top]. Lower part of offering-list, id. ib. fig. 89, p. 80.

(c) Wazet , Prophetess of Hathor, Noblewoman of the King, etc. Lintel and jambs of doorway with offering-texts, id. ib. fig. 90, p. 80. Texts from walls, id. ib. p. 81.

M.XIII. IMAMERYRĒ^c  IMAPEPY, Chief Justice and Vizier, etc. Temp. Pepy II.

JÉQUIER, *Le Monument funéraire de Pepi II*, iii, pp. 50-6, with plan and sections, fig. 49; id. in *Ann. Serv.* xxxiii (1933), p. 144 [upper].

Burial chamber.





West wall. Offering-text and offerings, id. *Le Monument* [etc.], pl. 52 [upper], pp. 52-3. Niche with palace-façade decoration and titles, id. ib. pl. 53, p. 53.

Monuments of deceased.

Fragments of false-door. Id. ib. fig. 50, pp. 53-4.

Wooden statue, uninscribed, found wrapped in linen, in Cairo Mus. JE 59631. Id. ib. pl. 54, p. 55; id. in *Mélanges Maspero*, i [1], pp. 109-12 with pl.; id. *Douze ans*, fig. 37, p. 131.

Other finds.

Offering-tables. Niṯankh-khons , Chief of the estate, etc., Neferi, same titles, Wepti , Seni , Director of the dining hall, and one dedicated by son Pepyemḥet , same title, id. *Le Monument* [etc.], figs. 51-5, p. 55.

Five shells with hieratic texts. Texts of three, id. ib. fig. 56, p. 55.

Obelisk of Idu-tepiḥu , King's eldest son, etc., probably from another tomb. Id. ib. fig. 57, pp. 55-6.

Secondary tomb.

Niḥesbed-neferkarē^c , Chief Justice and Vizier, etc. Temp. Pepy II.

Id. ib. pp. 56-60, with view, fig. 58; id. in *Ann. Serv.* xxxiii (1933), pp. 144 [lower]-145, with view, pl. ii. View, id. *Douze ans*, fig. 36, pp. 128-30; KOENIGSBERGER, *Die Konstruktion der ägyptischen Tür*, Taf. ii [2], p. 12.

False-door. JÉQUIER, *Le Monument* [etc.], fig. 60, p. 59.

Burial chamber.

Doorway. Lintel with offering-texts, id. ib. fig. 59 [upper], p. 59.

Walls. Offering-list, names of offerings and titles, id. ib. fig. 59 [lower], pp. 58-9.

False-doors found between tombs M.XIII and M.XIV

End of Dyn. VI or 1st Int. Period

Khnemhotp, Overseer of the Two Treasuries, etc. Id. ib. fig. 63, pp. 60-2.

Nefery, Chief of the estate. Id. ib. fig. 64, p. 62.

Neheri  , Greatest of the Five, etc. Id. ib. fig. 62, pp. 60-2.M.XIV. KHA'BAUKHNUM   BIU  , Chief Justice and Vizier, etc.
Temp. Pepy II.JÉQUIER, *Le Monument funéraire de Pepi II*, iii, pp. 62-7, with plan and section, figs. 65-6; id. in *Ann. Serv.* xxxiv (1934), pp. 76-7; DITTMANN in *Mitt. Kairo*, 6 (1936), p. 161 [bottom].Sealing with lions, gazelle and fish. JÉQUIER, *Le Monument* [etc.], fig. 68, p. 67.

Walls of burial chamber. Offering-texts, offering-list, and offerings, id. ib. pls. 52, 55, pp. 63-5.

M.XV. TETI, King's eldest son, Chief Justice and Vizier, etc. Temp. Pepy II.











JÉQUIER, *Le Monument funéraire de Pepi II*, iii, pp. 67-76, with plan, fig. 69; id. in *Ann. Serv.* xxxiv (1934), pp. 77-8; DITTMANN in *Mitt. Kairo*, 6 (1936), p. 161. Plan, JÉQUIER, *Douze ans*, fig. 35.**Chapel.**False-door and offering-table. Id. *Le Monument* [etc.], figs. 70-1, p. 69.**Room at entrance to sloping shaft.**

Obelisk-fragment with titles, in Cairo Mus. JE 63404, and fragment of another. Cairo JE 63404, id. ib. fig. 72, p. 69.

Offering-table with name, see id. ib. p. 70 [top].

Sloping shaft.

Walls. Titles of deceased written in ink, id. ib. p. 70 [bottom].

Antechamber and Burial Chamber.Walls. Offering-texts and titles accompanying representations of vases, id. ib. pp. 71-3. View of north wall of niche in Burial Chamber, id. in *Ann. Serv.* xxxiv (1934), pl. ii, p. 77.**Finds. Temp. Pepy II**Fragment of decree of Pepy II, in Cairo Mus. JE 63398. Id. *Le Monument* [etc.], fig. 74, p. 74 [bottom]; GOEDICKE, *Königliche Dokumente aus dem Alten Reich*, Abb. 14 (from JÉQUIER), pp. 156-7.Offering-tables of Nebi  , Scribe of the royal documents, Neby, Chief of the estate, etc., Khuit  , Treasurer of the King of Lower Egypt, Khnum , Count, Overseer of the *gs-pr*, etc., Idu  , King's eldest son, etc., Shemai  , Lector-priest, Ruz  , Treasurer of the King of Lower Egypt, etc., and one mentioning Khnemhotp. JÉQUIER, *Le Monument* [etc.], figs. 76-82, 75, p. 75.

Fragments with titles, id. ib. fig. 73, p. 74.

Wooden panel with painted scene of Pepy II and Hathor receiving life from Horus, in Cairo Mus. JE 62950. Id. ib. frontispiece, pp. 75-6; id. in *Ann. Serv.* xxxiv (1934), pl. i, p. 78; see id. *Douze ans*, pp. 130-1; *Descr. somm.* No. 6243.

Fragment of gilded wood with rosette and head of Seth-nubti. JÉQUIER, *Le Monument* [etc.], fig. 83, p. 76.

M.XVI. 'ANU , Inspector of prophets of the Pyramid of Pepy II, Overseer of the expedition, etc. Temp. Pepy II.

JÉQUIER in *Ann. Serv.* xxxv (1935), pp. 147-55, with plan, fig. 13; xxxiv (1934), p. 79; DITTMANN in *Mitt. Kairo*, vi (1936), p. 162.

Burial chamber.

Doorway. Lintel and jambs with offering-texts and titles, JÉQUIER in *Ann. Serv.* xxxv (1935), fig. 14, p. 149. Block of Henba , Treasurer of the King of Lower Egypt, etc., used for closing door; name and titles, id. ib. p. 150, cf. fig. 15.

Two rectangular coffins of deceased, wood. Texts, id. ib. fig. 16, pp. 150-1.

Box (containing model tools), wood. Names and titles, id. ib. p. 151 [bottom].

Statuette, with kilt covered with gold leaf, wood, in Cairo Mus. JE 63110. Id. ib. fig. 17, p. 153.

M.XVII. SEBKHOTP , Chief of the estate, etc. Temp. Pepy II.



JÉQUIER in *Ann. Serv.* xxxv (1935), pp. 34 [middle], 155-9.

Burial chamber.

Doorway. Remains of text on lintel, id. ib. p. 156 [top].

Walls. Offering-texts, offering-list and offerings, id. ib. figs. 18, 19, p. 156; view of west wall, id. *Douze ans*, fig. 31.

SOUTH OF PYRAMID OF PEPY II AND AROUND PYRAMID OF WEZEBTEN

KHUBAWY  (also ) Inspector of prophets of the Pyramid of Pepy II, Great overlord of the Thinite nome, etc. Temp. Pepy II.

Position not marked on map.

MASPERO, *Trois années de fouilles* [etc.] in *Mém. Miss.* i, p. 199 (as south-west of Pyramid of Pepy II), with plan and sections, figs. 2, 3, 5 (as Ninki), cf. 1.

Two obelisks and 'stèle-maison', found near subsidiary buildings of pyramid-enclosure of Wezebtan, latter in Cairo Mus. JE 49805. JÉQUIER, *La Pyramide d'Oudjebten*, figs. 34-5, pp. 27-8; id. in *Ann. Serv.* xxvi (1926), pl. vi, p. 55; man before deceased at table, FISCHER in *W.Z.K.M.* 57 (1961), fig. 2, pp. 75-7; Thinite nome-standard in title, id. in *J.A.O.S.* 74 (1954), fig. 7, pp. 30-1, cf. 31-2; see JÉQUIER, *Tombeaux de particuliers*, pp. 30, 32, cf. 129.

Burial chamber.

Walls with offering-texts, granaries, and offerings, MASPERO, op. cit. pls. i, ii, iii [A-E], iv, viii.

LS 32. ANTEF , Overseer of the *gs-pr*, Royal chamberlain, etc. Middle Kingdom.



Position not marked on map.

Two blocks with vases and titles, in Berlin Mus. 1152-3 (latter in East Berlin), *L. D. Text*, i, figs. on pp. 187 [bottom], 188 (numbers interchanged), cf. p. 187 [top]; texts, *Aeg. Inschr.* i, p. 156; see *Ausf. Verz.* p. 87.

VARIOUS FINDS

Late Old Kingdom unless otherwise stated



False-door of Theti , King's sole adorer (woman). JÉQUIER, *La Pyramide d'Oudjebten*, fig. 33, p. 26.

False-doors ('stèles-maisons'), of Iuiu , King's sole adorer (woman), in Cairo Mus. JE 49804, and Khenu , Overseer of the department of the Great House, etc., in Brussels, Mus. Roy. E.6303. Id. ib. figs. 37, 36, p. 28.

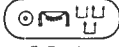
Offering-table of Hemi and Ikri, Inspectors of prophets, temp. Pepy II, and another of Nefery, Sole companion, etc. Id. ib. figs. 31-2, p. 26.

Support of statue or altar, with offering-text of Nubkaurē , Scribe, temp. Amenemhēt II or later, in Berlin (East) Mus. 1184. *L. D.* ii. 123 [c], *Text*, i, p. 187; text, *Aeg. Inschr.* i, p. 161; see *Ausf. Verz.* p. 88.

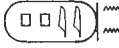
WEST OF PYRAMID OF PEPEY II

O.I. NIPEPY  (or NIKAPEPY ) NI (or NIKA), One who sets right the judgement, Secretary of the private hearing in the Six Great Courts, etc. Temp. Pepy II.

Position not marked on map.

JÉQUIER in *Ann. Serv.* xxxv (1935), pp. 141-3, with plan, fig. 8.

Burial chamber of deceased.

Section, MASPERO, *Trois années de fouilles* [etc.] in *Mém. Miss.* i, fig. 4 on p. 195 (as Rokhu).

Doorway (lintel formerly in Leipzig Mus. Inv.359, now lost). Conventional text of building tomb and threat, on lintel and jambs, PIEHL in *P.S.B.A.* xiii (1891), pp. 122-3 [c-e]; texts of lintel and one jamb, SETHE, *Urk.* i. 260 [18 (158)] (lintel collated).

Walls (including niche). Offering-texts, offering-list, granaries, and offerings, MASPERO, op. cit. pls. iii [F], vi, vii, pp. 196-9; two offering-texts, PIEHL, op. cit. p. 122 [a, b].

Second burial chamber.

Nude statuette, wood, in Cairo Mus. JE 58375. JÉQUIER, op. cit. fig. 9, pp. 142-3.

O.II. KHNEMU  (also KHNEMENTI ) Overseer of scribes of the royal documents, etc. Temp. Pepy II.

Position not marked on map.

JÉQUIER in *Ann. Serv.* xxxv (1935), pp. 143-6, with plan, fig. 10.

Fragment of jamb of false-door, with deceased at table. Text, id. ib. p. 143.

Fragment of head of alabaster statue, in Cairo Mus. JE 58377. See id. ib. p. 145.

Burial chamber.

Walls. Fragment of offering-list, texts of granaries, and names and titles, id. ib. fig. 11, pp. 145-6.

NEMTIEMZEREF , Overseer of tenants of the Great House. Temp. Pepy II.

Position not marked on map.

Offerings on walls of burial chamber, MASPERO, *Trois années de fouilles* [etc.] in *Mém. Miss.* i, pl. v, p. 199.



VARIOUS FINDS FROM AND AROUND THE PYRAMID-COMPLEX
OF PEPEY II

Late Dyn. VI.

Male statuette, much damaged, wood, in Neuchâtel Mus. Eg.404. GABUS, *La Collection égyptologique* [etc.] in *Formes et Couleurs*, xi [1] (1949), 5th fig.; JÉQUIER, *Le Monument funéraire de Pepi II*, iii, fig. 16, p. 35 [14].

Head of large male statue, wood, Dyn. VI(?), in Cairo Mus. Temp. No. 13.4.28.9. Id. ib. fig. 17, pp. 35-6 [15].

Two female statuettes, wood, late Dyn. VI. See id. ib. p. 35 [12, 13].

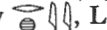
False-door of Imapepy , Scribe of the royal documents, id. ib. fig. 21, p. 38 [1]; of Sedekh , Overseer of linen (*sšrw*), fig. 22, p. 38 [2]; fragment of false-door of Rekhy , Lector-priest, fig. 23, p. 38 [3].

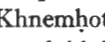
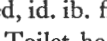
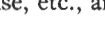
Fragments of lintel of Khnemhotp , Overseer of tenants of the Great House, etc., with several figures of deceased, id. ib. fig. 25, p. 38 [5]; of lintel with Shema , Eldest lector-priest, Secretary of the Toilet-house, etc., and wife Mert , King's sole adorer, fig. 26, pp. 38-9 [6].

Offering-table of Mereri , Honoured by the Lord of Panopolis, and others. Id. ib. fig. 24, p. 38 [4].

Middle Kingdom.

Block statue-group, two couples squatting, remains of text, fragments, granite, in Neuchâtel Mus. Eg.405. Id. ib. figs. 19, 20, pp. 36-7 [17]; see BOTHMER in *Brooklyn Museum Annual*, ii-iii (1960-2), p. 35 [xxv].

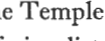
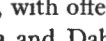
Stela, Neferḥor , Overseer of butchers in temples, Steward of the chamber of fat, Director of craftsmen in the Temple of Ptaḥ, etc., son of Rerut , (woman), represented twice at table, with offering-list above, and below, twelve *warb*-priests called after kings buried at Ṣaqqâra and Dahshûr, including two called Ameny (i.e. Amenemḥêt), Meryrēc (Pepy I), Khety(?) , two Neferkarēc (Pepy II and another), Snefru, Nubkaurēc (Amenemḥêt II), etc., before deceased at table (twice), in Cairo Mus. JE 51733. JÉQUIER, op. cit. fig. 29, pp. 39-42 [9]; see id. in *Ann. Serv.* xxvii (1927), p. 61.

New Kingdom.

Two small stelae, man adoring Amen-rēc, Ramesside, and Pentawēr , adoring Sobk, in Neuchâtel Mus. Eg.352, 351. Id. *Le Monument funéraire de Pepi II*, iii, figs. 30-1, p. 42 [10, 11].

Stela (name lost), Anubis with scales before Osiris, and below, tree-goddess scene with priest libating, Ramesside, in Cairo Mus. JE 66149. Id. ib. fig. 32, pp. 42-3 [12]; id. in *Ann. Serv.* xxxvi (1936), fig. on p. 17, cf. p. 19.

Mirror with handle with four nude female figures in faience and wood, Dyn. XVIII, in Cairo Mus. JE 50280. JÉQUIER, *Le Monument funéraire de Pepi II*, iii, fig. 39, p. 44.

EAST OF MAṢṬABET FARA'ÛN



SENI , Count. Late Dyn. VI.

Wife, Meres'ankh , King's sole adorer.

Against south wall of the Causeway. Position not marked on map.

JÉQUIER, *Le Mastabat Faraoun*, p. 29, with plan and sections, fig. 26.

Small doorway (stela?). Id. ib. fig. 27, p. 29.

M.VIII. SETIBTI  BEBI , Noblewoman of the King, Prophetess of Ḥathor, King's sole adorer. End of Dyn. VI or 1st Int. Period.

Above wâdi, 300 metres east of Maṣṭabet Fara'ûn.

JÉQUIER, *Tombeaux de particuliers*, pp. 55-8, with plan, fig. 61.

Doorway of principal burial chamber. Lintel and jambs with offering-text, id. ib. fig. 62, p. 56.

FOUND NEAR MAṢṬABET FARA'ÛN

Bust and head, Middle Kingdom, in Cairo Mus. JE 51956-7.

False-door of Iḥy , Dyn. VI or later, in Cairo Mus. JE 41570 (probably also Temp. No. 19.11.24.20).

False-door of Senti , Noblewoman of the King, Prophetess of Ḥathor, late Dyn. VI. JÉQUIER, *Le Mastabat Faraoun*, fig. 24, p. 29 with note 1. Architrave with three figures of deceased, with a dealer in Cairo in 1977.

False-door fragment of Pepy . . .  . . . , Lector-priest, Scribe of a phyle, late Dyn. VI. Id. ib. fig. 25, p. 29.

Two adjoining blocks from side-piece of niche of Ptaḥhotp, son of Ameny, both Butchers, and Ḥenut  (mother), decorated on two faces, (a) address to *warb*-priests of Shepseskaf and to the living, (b) registers, lector-priest with offering-list, animals and fowl, and relatives before offerings, Dyn. XII, in Cairo Mus. JE 51979. Id. ib. pl. xii, p. 31.

Stela-fragment of Amenmosi, son(?) of Nebt-ḥet  (woman), New Kingdom. Id. ib. fig. 29 on p. 33.

Block with deceased seated and girl squatting on chair underneath, New Kingdom. Id. ib. fig. 28 on p. 33.

Offering-table of Impy , Scribe of the royal documents in the presence, Dyn. V-VI, in Cairo Mus. CG 1344. Text, BORCHARDT, *Denkmäler*, i, p. 21.

NEAR PYRAMID OF USERKARĒ^c KHENZER

IRI , Great overlord of the Panopolite nome, Lector-priest, etc. End of Dyn. VI or 1st Int. Period.

Position not marked on map.

About 18 metres north-east of the Pyramid.

JÉQUIER, *Deux pyramides du Moyen Empire*, pp. 39-43.

Burial chamber. Painted decoration on brick-built walls.

Doorway. Remains of name of deceased, see id. ib. p. 39 [near bottom].

Walls. Offerings, offering-texts, and texts of offerings and granaries, id. ib. figs. 29, 30, 32, cf. 31, pp. 40-3.

FOUND NEAR THE PYRAMID

Faïence kohl-tube with names of Amenophis III and Queen Teye. Id. ib. pl. x [17], p. 44 [bottom].

EXACT POSITION UNKNOWN

D 67. NEKHT-SAS , Supervisor of prophets of the Sun-temple and Pyramid of Neuserre^c, Prophet of the Sun-temple of Neferirkarē^c, etc. Temp. Neuserre^c or later.

False-door, in Cairo Mus. JE 15152. MARIETTE, *Mastabas*, fig. on p. 366.

Jamb, in Cairo Mus. CG 1440. Text, BORCHARDT, *Denkmäler*, i, p. 122.

D 68. KHNEMT  (woman). Dyn. V-VI.

False-door, in Cairo Mus. CG 1399. Id. ib. Bl. 16, p. 60; MARIETTE, *Mastabas*, fig. on p. 367; VANDIER, *Manuel*, ii, fig. 278 [upper left], p. 404.

D 69. SHEDABD . Dyn. VI or 1st Int. Period.

False-door, in Cairo Mus. CG 1453. BORCHARDT, *Denkmäler*, i, Bl. 34, pp. 138-40; MARIETTE, *Mastabas*, fig. on pp. 368-9.

E 16. SESI , Chief Justice and Vizier, Inspector of prophets of the *mert*-temple of Pepy I, etc. End of Dyn. VI or 1st Int. Period.

False-door, incomplete. Id. ib. fig. on p. 420.

J. TOMBS OF POSITION UNKNOWN

(a) OLD KINGDOM

B 8. KHUENPTAḤ , Overseer of craftsmen, Prophet of Ptaḥ and Sokari, etc. Middle Dyn. V or later.

MARIETTE, *Mastabas*, p. 98, with plan of chapel.

Two offering-stands, in Cairo Mus. CG 1295, 1297 (as 1298, 1301 in 1st ed.). BORCHARDT,

Denkmäler, i, Bl. 1 (CG 1295), pp. 1, 2; MARIETTE, *Album du Musée de Boulaq* (1872), pl. 11; one, see MASPERO, *Guide*, p. 67 [144].

Drum. MURRAY, *Saqqara Mastabas*, i, pl. iii [3], and SETHE in ii, p. 12 [15].

B 14. AKHI , Inspector of scribes of the house of the master of the largesse, etc. Late Dyn. V or Dyn. VI.

MARIETTE, *Mastabas*, pp. 106-7, with plan of chapel.

Statue-group, deceased seated, with wife (no name) and daughter Duatnub , Prophetess of Hathor, etc., squatting, in Cairo Mus. CG 44. BORCHARDT, *Statuen*, i, Bl. 11, pp. 40-1; WEIGALL, *Anc. Eg. . . . Art*, 70 [upper right]; TARCHI, *L'Architettura*, Tav. 14 [upper left]; CAPART, *L'Art ég.* (1909), pl. 19; id. *L'Art ég.* ii, pl. 260; FECHHEIMER, *Plastik*, Taf. 31; PEET in HAMMERTON, *Universal History of the World*, i, fig. on p. 498 [upper] (as Brit. Mus.); CAROTTI, *L'Arte*, figs. 41-2; SHOUKRY, *Privatgrabstatue*, Abb. 19; HORNE-MANN, *Types*, v, pl. 1398; ALDRED, *O.K. Art*, pl. 50; DE RACHEWILTZ, *L'Arte*, Tav. 41, p. 53; DAUMAS, *Civ. de l'Ég.* pl. 82; *Great Museums*, pl. 28; wife and daughter, PETRIE, *Arts and Crafts*, fig. 30 facing p. 35; SAMEH, *Daily Life*, fig. on p. 117; wife, CAPART, *L'Art ég.* (1911), pl. 116; id. *Propos*, fig. 12; id. *Schoonheidsschatten uit Oud-Egypte*, fig. 9; id. *Limites*, pl. iv [2], p. 43; id. *Documents*, i, pl. 10; DE WIT, *Oud-Egyptische Kunst*, fig. 27 facing p. 56; PIJOÁN, *Summa Artis*, iii (1945), fig. 137 (as Kai); PIRENNE, *Hist. civ.* i, pl. 65 facing p. 200; texts, MARIETTE, *Mastabas*, p. 107 [lower].

C 12. RAḤOTP , King's adorer, Overseer of sculptors, etc. Middle Dyn. V or later.

Wife, Thentet , Royal acquaintance.

MARIETTE, *Mastabas*, p. 135, with plan.

Names and titles on lintel of doorway, id. ib. p. 135.

C 25. KAEMREḤU , Overseer of butchers of the slaughterhouses of the Great House, etc. Middle Dyn. V or later.

MARIETTE, *Mastabas*, pp. 159-60, with plan of chapel.

Doorway. Lintel with offering-texts, dedicated by son Hetep, Judge and Inspector of scribes, id. ib. fig. on p. 160; VASSALLI MSS. 11 [bottom]; text of lines 3 and 4, SETHE, *Urk.* i. 33-4 [20].

C 27. KAIḤAP , Overseer of *ka*-servants, Judge and Inspector of scribes, etc. Dyn. V.

MARIETTE, *Mastabas*, pp. 162-4, with plan of chapel.

Finds. In Cairo Museum.

Statue of deceased, CG 129. BORCHARDT, *Statuen*, i, Bl. 29, p. 97; upper part, DAUMAS and GHALIOUNGUI in *Chron. d'Ég.* li (1976), fig. 2, pp. 23-4; text, MARIETTE, op. cit. p. 164 [left].

Statuette of woman grinding corn, CG 115. BORCHARDT, op. cit. Bl. 25, p. 89; MASPERO, *Égypte*, fig. 15; PETRIE Giza photo. 534.

Ointment-slab (name as Kaiḥap-wēr ) alabaster, CG 1338. MARIETTE, op. cit. fig. on p. 163 [bottom]; text, BORCHARDT, *Denkmäler*, i, p. 18.

Offering-table, CG 1305. Id. ib. i, Bl. 1, p. 5; MARIETTE, op. cit. p. 164 [right].

GEḠI , Inspector of prophets of the Pyramid of Merenrē I, Great overlord of the Thinite nome, Overseer of prophets of Onuris, etc. Dyn. VI.

(Another tomb of probably same man at Nag^c el-Deir, N.90.)

False-door, in Cairo Mus. CG 1455. BORCHARDT, *Denkmäler*, i, Bl. 35, pp. 142-3. Two nome-emblems in title, FISCHER in *J.A.O.S.* 74 (1954), figs. 3, 4, p. 30.

Six seated statues, in Cairo Mus. CG 70-5. BORCHARDT, *Statuen*, i, Bl. 17 (CG 72, 75), pp. 60-2. CG 73, HORNEMANN, *Types*, iii, pl. 693. Nome-emblems in titles of two, FISCHER, op. cit. figs. 1, 2, p. 29.

INPUKHA^c , Overseer of King's adorners of the Great House, etc. Dyn. V.

Parents, Ni^cankhrē and Ḥepetka (tomb F 1).

Fragment of false-door, lintel with jambs, and another lintel, in Chicago, Field Mus. Nat. Hist. A.31690, 31299, 31308.

IRUKAPTAḤ , Overseer of the granary, Scribe of the royal documents of the granary, Prophet of Rē, etc. Late Dyn. V.

Berlin (East) Museum. Formerly in Clot Bey Collection.

View of some objects, *Aeg. und Vorderasiat. Alterthümer*, on Taf. 10, 92; *Ausf. Verz.* on Abb. 7, p. 64.

Six offering-stands, four of them with granite bowls, Nos. 1111-12, 1144-5, 1193-4. L. D. *Text*, i, figs. on p. 13, cf. 12 [8]. Nos. 1111-12, SCHÄFER and ANDRAE, *Kunst* (1925), 259 [left and right lower]; (1930 and 1942), 269 [left and right lower] (as Nos. 1193-4). Texts, *Aeg. Inschr.* i, p. 54.

Offering-tables, two alabaster and two limestone, Nos. 1140, 1202, 1139, 1201. L. D. *Text*, i, figs. on p. 14, cf. p. 12. No. 1201, *Aeg. und Vorderasiat. Alterthümer*, Taf. 9 [upper right]; SCHÄFER and ANDRAE, op. cit. (1925), 259 [right upper]; (1930 and 1942), 269 [right upper]; see *Führer* (1961), p. 46. Texts, *Aeg. Inschr.* i, p. 53.

Brooklyn Museum. Formerly Abbott and N.Y. Hist. Soc. Collns.

Statue of man seated, with *ka*-servants on sides of seat, No. 37.20E. HORNEMANN, *Types*, iii, pl. 703. Two men censuring and libating on left side of seat, FAZZINI in *Miscellanea Wilbouriana*, 1 (1972), fig. 9, p. 42. Texts, JAMES, *Corpus*, i, pl. xxi [44], pp. 16-17. See L. D. *Text*, i, p. 14; BONOMI, *Cat. Colln. Abbott*, p. 2 [10]; *N.Y.H.S. Cat.* p. 8 [116].

Statue-group, man, with small son and kneeling wife by his legs, No. 37.17E. DINSMOOR in *Proceedings of the American Philosophical Society*, 87 [1] (1943), fig. 19 facing p. 96; ANTHES, *Aeg. Plastik*, Taf. 23; COONEY in *Brooklyn Mus. Bull.* xiii [3] (Spring 1952), figs. 5, 6, pp. 11-15; HORNEMANN, *Types*, v, pl. 1409; WOLF, *Die Welt der Ägypter*, Taf. 17; ALDRED, *The Egyptians*, pl. 13; id. in PIGGOTT, *The Dawn of Civilization*, pl. on p. 116 [43]; SAINTE FARE GARNOT, *L'Égypte*, fig. on p. 78 [middle]; *Eg. Art . . . Brooklyn*, fig. 15;

RIEFSTAHL, *People of the Black Land, Egypt*, Ser. i, No. 3, 1st fig.; FAZZINI, *Art from the Age of Akhenaten*, fig. 2; id. *Images for Eternity*, Cat. No. 25; *Ägyptische Kunst aus dem Brooklyn Museum* (Berlin, Ägyptisches Museum, 4. Sept.–31. Okt. 1976), No. 16; VANDER-SLEYEN, *Das Alte Ägypten*, Abb. 139; *Égypte Éternelle. Chefs-d'œuvre du Brooklyn Museum* (Palais des Beaux-Arts, Bruxelles, 9 décembre 1976–20 février 1977), No. 16. See L. D. Text, i, p. 14; BONOMI, *Cat. Colln. Abbott*, p. 2 [9]; *N.Y.H.S. Cat.* p. 14 [186].

Two offering-stands, with granite bowls, Nos. 37.18E and 37.19E. GESELL in *A.ÿ.A.* 80 (1976), pl. 45 [26], p. 254. One stand and bowl, WILKINSON MSS. ix. 117 [middle], xli. 43 verso [near bottom left and middle]. Texts, JAMES, *Corpus*, i, pl. xxi [45–6], p. 17. See BONOMI, *Cat. Colln. Abbott*, p. 2 [7]; *N.Y.H.S. Cat.* p. 14 [184–5].

IRY , King's *wacb*-priest, etc. Dyn. IV or later.

Wife, Inti (var. Int) , *mitrt*, etc.
Perhaps from here (or Giza).

British Museum.

Upper part of false-door, No. 1171. *Hiero. Texts*, i, pl. 16 [42]; i², pl. iii [2], p. 3; hieroglyph , FISCHER in *ÿ.A.R.C.E.* ii (1963), fig. 1, p. 23.

Two thicknesses, deceased with sons, and wife with children, Nos. 1168, 1170. *Hiero. Texts*, i, pl. 16 [43, 73]; i², pl. iii [3, 4], pp. 3–4; upper part of wife, MURRAY in *Anc. Eg.* (1917), pl. facing p. 49; names, *Guide (Sculpture)*, pp. 14 [43], 22 [73].

Block with deceased, No. 1169. *Ib.* fig. on p. 14, cf. p. 13 [41]; *Hiero. Texts*, i, pl. 17 [41]; i², pl. iii [1], p. 3.

Chicago, Field Museum of Natural History.



Drums of deceased, A.31708, 31730.

Lintel with name and titles of wife, and another with offering-text of deceased, A.31707, 31728.

ITI , King's *wacb*-priest, Judge and Scribe, etc. Dyn. V.

West wall of chapel. Two false-doors with estates on jambs and offering-list between them, in Cairo Mus. CG 57192; offering-list, HASSAN, *Giza*, vi [2], pls. lxxv–lxxii [73], p. 134; names of estates, JACQUET-GORDON, *Domaines*, pp. 378–9 [2385], cf. figs. 150–1; man carrying calf, from left false-door, TZARA and SVED, *L'Égypte face à face*, pl. on p. 88 (reversed); see MASPERO, *Guide*, p. 89 [240].

KAEMTHENENT , Judge and Master of the largesse, etc. Dyn. V.

Mother, Henutsen , Royal acquaintance. Wife (of deceased rather than of Wetka), Mertiotet .

Cairo Museum.

False-door, with wife and Wetka , Judge and Elder of the dockyard, on jambs, CG 1456. BORCHARDT, *Denkmäler*, i, Bl. 35, pp. 144–5. Some text, DE ROUGÉ, *Inscr. hiéro.* pl. v [middle]. Names and titles, LIEBLEIN, *Dict.* No. 1388.

Lintel, dedicated by deceased to mother, CG 1691. Text, BORCHARDT, *op. cit.* ii, p. 137; DE ROUGÉ, *op. cit.* pl. v [top]; part, SETHE, *Urk.* i. 34 [21].

Offering-table of deceased mentioning wife and Wetka, CG 1371. Text, BORCHARDT, *op. cit.* i, p. 33.

KAHERSETEF , Inspector of scribes of the sealed documents, Greatest of the Ten of Upper Egypt, etc. Dyn. V.

Wife, Mertib .

False-door. Part, in Cairo Mus. CG 1515; texts, BORCHARDT, *Denkmäler*, i, pp. 218–19. Lintel, perhaps belonging, formerly in Golenishchev Colln. 4059, now in Moscow Mus. I. 1.b.320.

Block with serdab-aperture at top, and four registers below, deceased and wife at tables, son, and daughter, and people, in Cairo Mus. CG 1566. *Id. ib.* ii, Bl. 66, pp. 35–6; line of text above serdab-aperture, SETHE, *Urk.* i. 10 [8].

Wooden door-wing with five registers of people, in two parts, one in Cairo Mus. CG 1568, the other in Paris, Mus. Guimet. BORCHARDT, *op. cit.* ii, Bl. 68, pp. 38–9; RICKE, *Die Schrift in der ägyptischen Baukunst in Die zeitgemässe Schrift*, Heft 47 (Oct. 1938), Abb. 5, p. 32; some names, LIEBLEIN, *Dict.* No. 1731.

KAPUPTAḤ , Prophet of Rē^c and Ḥaṭḥor in the Sun-temple of Neferirkarē^c, Prophet of the Pyramid of Zadkarē^c (Isesi), etc. Temp. Isesi or later.

Objects in Cairo Museum.

False-door, CG 1563. BORCHARDT, *Denkmäler*, ii, Bl. 64, pp. 26–8.

Blocks with three registers, feet of [deceased seated], with monkey tied to chair, offering-bringers, and estates, CG 1711, 1567. *Id. ib.* Bl. 91, 67, pp. 150, 36–7; names of estates, JACQUET-GORDON, *Domaines*, p. 377 [22S5], cf. fig. 149; ČERNÝ Notebook, 118, p. 95.

Lintel, CG 57160, and block with offering-bringers, CG 57161.

KATEP , Overseer of works of the King, Director of King's *warb*-priests, Boundary official (*r_d*) of the northern settlement, Prophet of Khufu, etc. Probably Dyn. V.

Parents (possibly), Katep and Tepemnefert (tomb, *Bibl.* iii.² 52).

Wife (probably) Ḥetepheres , Royal acquaintance.

Perhaps from here (or Gîza).

London, British Museum.

Three pieces, perhaps from same false-door, Nos. 1173–4, 1288. *Hiero. Texts*, i, pl. 9; i², pl. v, pp. 5–6.

Double statue, deceased and wife seated, No. 1181. BUDGE, *Egyptian Sculptures in the British Museum* (1914), pl. ii; *id. By Nile and Tigris*, ii, pl. facing p. 338; *id. The Mummy* (1925), pl. iv [right]; *id. A History of Egypt*, ii, fig. on p. 137; *Guide, Eg. Colln.* (1909), fig. on p. 177; (1930), fig. 143 on p. 262; (1964), fig. 64; WILKINSON (A.) in FRANCIS, *Treasures of the British Museum*, fig. 75. Text, *Hiero. Texts*, vi, pl. 19 [14]. See *Guide (Sculpture)*, p. 5 [14].

Two offering-stands (one uninscribed, the other with name and titles), Nos. 27339-40. See *Hiero. Texts*, i², p. 5; *Guide*, 4th to 6th, p. 14 [1, 2].



Chicago, Field Museum of Natural History.

See FISCHER, *Varia*, pp. 35-7.

Drum of deceased, A.31710. Id. ib. pl. ix [18], fig. 13.

Parts of false-door of wife, A.31711. Id. ib. pl. ix [19], fig. 14.

Parts of doorway, A.31709. Lintel with offering-text. Thicknesses, (a) left, deceased and wife, with estates behind them and offering-bringers below, (b) right, deceased, wife, and child, and offering-bringers below. Id. ib. pls. x-xi [20-2], figs. 10-12, cf. 15; names of estates, JACQUET-GORDON, *Domaines*, p. 333 [6S5], cf. fig. 119.

MARU  BEBI , Overseer of tenants of the Great House, Scribe of a boat's side, Honoured by Merenrē I, etc. Dyn. VI.

Burial chamber. In Brussels, Mus. Roy. E.2243.

CAPART, *Chambre funéraire de la sixième dynastie*, passim; see SPELEERS, *Rec. inscr.* p. 7 [51].

Three walls. Offering-list, granaries, funerary equipment, and texts, CAPART, op. cit. pls. i-v, fig. 12; remains of threat, SETHE, *Urk.* i. 255-6 [14 (154)].

NI'ANKHNESUT , Count, Overlord of Nekheb, Director of *ka*ka-boats, etc. Early Dyn. VI.

See SMITH in *A. J. A.* xlvi (1942), p. 510 with note 5; id. *Hist. Eg. Sculp.* p. 208 note 1.

Blocks. Many formerly in Hirsch Colln.

Berlin (West) Museum.

Two, gardening and procession of offering-bringers, and offering-bringers in canoe, No. 3/65. KAISER, *Äg. Mus. Berlin* (1967), pp. 28 [237], 32 [295] with Abb.

Cambridge (Mass.), Fogg Art Museum.

Two, man holding cow by rope, and two men with joints of meat, Nos. 1934.17, 18. GRACE in *Bulletin of the Fogg Art Museum, Harvard University*, v (1936), figs. 1-3, pp. 30-5.

Cleveland (Ohio), Museum of Art.

Men bringing wild animals, No. 30.734. R. H[OWARD] in *Cleveland Mus. Bull.* xvii (1930), fig. on p. 195 [lower], cf. p. 189 with note 1 (as No. 799.30).

Man seated, No. 30.735. Id. ib. fig. on p. 185, cf. p. 188 with note 1 (as No. 800.30); MILLIKEN in ib. xxviii (1941), fig. on p. 101 [left], cf. p. 91.

Registers, I, sowing and ploughing, II, pulling and binding flax, with flutist, III (upper part only), reaping corn, including man drinking, No. 30.736 (adjoins No. 30.136). R. H[OWARD], op. cit. fig. on p. 186, cf. pp. 188 with note 2 (as No. 801.30), 189; WRESZ., *Atlas*, iii. 54; *Handbook* (1958), fig. 2; (1966), fig. on p. 2 [upper right].

Three offering-bringers, No. 30.737. R. H[OWARD], op. cit. fig. on p. 195 [upper left], cf. p. 189 with note 2 (as No. 802.30).

Registers, **I** (lower part only), man with fowl, **II**, bringing cattle, No. 30.738. Id. ib. fig. on p. 198 [lower], cf. pp. 189 with note 3 (as No. 803.30), 190.

Block with remains of texts, including name of Unis'ankh, No. 30.136 (adjoins No. 30.736). Name, id. ib. fig. on p. 195 [upper right], cf. p. 187 with note 1.

Detroit, Institute of Arts.

Men netting fish, and bringing cattle, including man carrying calf, No. 30.371. RICHARDSON in *Bulletin of The Detroit Institute of Arts of the City of Detroit*, xii (1931), figs. on pp. 33-5; *Detroit Institute. Paintings and Sculpture Illustrated* (1943), fig. on p. 5; *Masterpieces of Painting and Sculpture from The Detroit Institute* (1949), pp. 1-3 with fig.; *Treasures from The Detroit Institute of Arts* (1960), fig. on p. 16.

Edinburgh, Royal Scottish Museum.

Lower part of large figure of deceased, and before him, offerings and men dragging statue, with one of them censuring, and below, offering-bringers,¹ No. 1958.46. See ALDRED in *The Royal Scottish Museum Triennial Report 1971-3*, p. 28.

Geneva, Musée d'Art et d'Histoire.

Deceased, Inv.19491. CASTIONI and others, *Égypte* (1977), No. 5 with fig.; MAYSTRE in *Les Musées de Genève*, xii [9] (Oct. 1955), fig. 3 on 2nd page.

Offerings, and offering-bringers below, Inv.19490. Id. ib. fig. 2 on 2nd page.

Offering-bringers, Inv.19627. Id. *Égypte antique* (1963), fig. on p. 10.

Hanover, Kestner-Museum.

Offering-list with priests below, No. 1972.19. *Antike Kunstwerke. Ars Antiqua AG Luzern Auktion*, May 2, 1959, Taf. 2 [3], p. 5; three priests, *Hannover. Kestner-Museum. Jahresbericht 1970-1973*, fig. 1 on p. 306, cf. p. 307.

Honolulu, Academy of Arts.

Deceased with staff. *Honolulu Academy of Arts* (1937), fig. on p. 59.

Jerusalem, The Samuel Bronfman Biblical and Archaeological Museum.

Food-offerings, No. 71.89.339. *Antike Kunstwerke. Ars Antiqua AG Luzern Auktion*, April 29, 1961, Taf. 1 [3], p. 5; *Me-ōsaroth Mišrayim ha-'atiqah be-Yisra'el* (Kibus Hazore'a, Beth Wilfrid Yisra'el, 1969), No. 78 with fig.; *The Israel Museum News*, 10 (April 1975), fig. 14 on p. 116, cf. p. 107.

Kansas City, William Rockhill Nelson Gallery of Art.

Registers, **I**, papyrus-harvest, making ropes, and building papyrus-canoe, **II**, boatmen jousting, **III** (upper part only), men bringing fish, [cutting out] roes of fish, and bringing cattle, No. 34.14. RANKE, *The Art of Ancient Egypt*, and BREASTED, *Geschichte Aegyptens* (1936), 204; Kansas City. *Handbook* (1933), fig. on p. 115; (1959), figs. on p. 16 [top and middle]. **I**, two men tying bundle of papyrus, SMITH, *Hist. Eg. Sculp.* fig. 221 [upper right], p. 338; circumcised man squatting in canoe, JONCKHEERE, *La Circoncision* [etc.] in *Centaurus*, i (1951), fig. 4, p. 225. Man with papyrus and 1st canoe on right in **II**, *The William Rockhill Nelson Collection* (1949), fig. on p. 12 [upper].

Los Angeles, County Museum of Art.

Deceased seated, No. 47.8.3. BREASTED (Jr.) in *Bulletin of the Art Division. Los Angeles County Museum*, i [2] (1947), front cover, p. 5; *Illustrated Handbook of the Los Angeles*

¹ Another block from the same scene in Brooklyn Mus. L76.11.2.

County Museum of Art (1965), fig. on p. 17; *Los Angeles County Museum of Art Handbook* (1977), fig. on p. 50.

Priests libating, etc., No. 47.8.5. BREASTED (Jr.), op. cit. fig. 3, pp. 5-7.

Munich, Staatliche Sammlung Ägyptischer Kunst.

Two registers of butchers, ÄS 5970. *Antike Kunstwerke. Ars Antiqua AG Luzern Auktion*, May 2, 1959, Taf. 1 [2], p. 5; MÜLLER (H. W.) in *Münchener Jahrb.* 3 Ser. xxv (1974), Abb. 4, p. 217; *Staatl. Samml.* (1976), figs. on pp. 48-9; 1st to 6th butchers from left in **II**, ib. (1972), pl. 17, p. 39; 2nd to 6th, Zürich. *5000 Jahre*, Abb. 37, p. 61 [130]; 2nd to 7th, Essen. *5000 Jahre*, No. 45 with Abb.

Oberlin College, Ohio, Allen Memorial Art Museum.

Lector-priest and offering-bringers, No. 43.302. Lector-priest and two men, *Allen Memorial Art Museum Bulletin*, xi [2] (1954), No. 1; xvi [3] (Spring 1959), fig. on p. 158. See ib. xvi [2] (Winter 1959), p. 108 [177].

Worcester (Mass.), Art Museum.

Deceased in canoe fowling, with sons, officials, and dwarf holding dog and monkey on leash, No. 1931.99. F. H. T[AYLOR] in *Bulletin of the Worcester Art Museum*, xxiii (1932), figs. on pp. 11, 13, 15 [lower]; Worcester Art Museum. *Art through Fifty Centuries* (1948), fig. 1; *A Handbook to the Worcester Art Museum*, fig. on p. 14.

In private collections.

Offering-bringers, in Borowski Collection. *Man in the Ancient World* (Exhib. New York, Queens College, Flushing, Feb. 10-March 7; 1958), pl. 91; five of them, *Mostra di Sculture Antiche* (Bergamo, August-September 1958), pl. i, p. 1. See Zürich. *5000 Jahre*, p. 61 [131].

Offering-bringers in canoe before deceased (feet only), and dwarfs with dogs, monkey, and panther, in Kofler-Truniger Colln. MÜLLER (H. W.), *Ägyptische Kunstwerke, Kleinfunde und Glas in der Sammlung E. und M. Kofler-Truniger, Luzern*, pl. A90, pp. 56-7; *Geschenk des Nils. Ägyptische Kunstwerke aus schweizer Besitz* (Eine Ausstellung des Ägyptologischen Seminars der Universität Basel, 1978), No. 122 with pl.

Formerly in Hirsch Collection, present location unknown. Butchers; *Classical Antiquities. Münzen und Medaillen A.G. Auction Sale*, June 30, 1956, pl. 43 [187], p. 50. Offerings and kneeling priest; *Antike Kunstwerke. Ars Antiqua AG Luzern Auktion*, May 2, 1959, Taf. 2 [4], p. 6. Two registers, men bringing oxen, and upper parts of female offering-bringers; ib. Taf. 1 [1], p. 5. Deceased with small son; ib. April 29, 1961, Taf. 1 [1], p. 5. Duck in papyrus thicket; ib. Taf. 1 [2], p. 5.

NIKARĒꜥ , Inspector of scribes of the granary, Prophet of RĒꜥ in the Sun-temple of NeuserrĒꜥ, etc. Temp. NeuserrĒꜥ or later.

Wife, Nikaunub , Royal acquaintance.

Blocks, etc.

Right jamb of false-door, with deceased and son 'AnkhmaꜥrĒꜥ , Overseer of the granary, in Cleveland Mus. 64.91. *Cleveland Mus. Bull.* li (1964), fig. 67 on p. 237, cf. p. 263; *Handbook* (1966), fig. on p. 2 [upper middle]; *The Art Quarterly*, xxvii (1964), pl. on p. 379 [bottom left] (top left corner not shown).

Blocks, see COONEY in *Brooklyn Mus. Bull.* xiii [3] (Spring 1952), p. 8.

Statues.

Statue-group, deceased seated, with wife and son Ḥankhmaḥrē, in Brooklyn Mus. 49.215. Id. ib. pp. 1-9 with front cover and figs. 1-4; *Brooklyn Mus. Ann. Rep. 1949-50*, fig. on p. 4; SCOTT in *M.M.A. Bull.* n.s. xi (Dec. 1952), fig. on p. 120, cf. pp. 118, 122; *Eg. Art . . . Brooklyn*, fig. 16; HORNEMANN, *Types*, v, pl. 1412. Texts, JAMES, *Corpus*, i, pl. xix [36], p. 13; FISCHER in *Metropolitan Museum Journal*, 8 (1973), fig. 9, p. 8 note 8.

Statue-group, deceased seated, with small daughter and kneeling wife, formerly in Benzion Colln., now in New York, M.M.A. 52.19. SCOTT, op. cit. figs. on pp. 121-2, cf. pp. 118-22; id. ib. n.s. xxxi (Spring 1973), fig. 4 on p. 126; HAYES, *Scepter*, i, frontispiece; FISCHER in *Apollo*, lxxxii (1965), figs. 4, 5, pp. 171-2.



Deceased seated, granite, in Cleveland Mus. 64.90. *Cleveland Mus. Bull.* li (1964), fig. 68 on p. 236, cf. p. 263; *Handbook* (1966), fig. on p. 2 [upper left]; *The Art Quarterly*, xxvii (1964), pl. on p. 379 [bottom right].

Deceased as scribe reading, granite, formerly in Benzion Colln., now in New York, M.M.A. 48.67. HAYES in *M.M.A. Bull.* n.s. vii (Oct. 1948), fig. on p. 61; *Guide to the Collections. Egyptian Art* (1962), fig. 11.

NIKAURĒ , Overseer of works of the King, Prophet of the Pyramid of Zadkarē (Isesi). Temp. Isesi or later.

Names and titles, DE ROUGÉ, *Inscr. hiéro.* pl. xci [middle left].

NIKAURĒ , Judge and Inspector of book-keepers, Prophet of Rē and Hathor in the Sun-temple of Neferirkarē, etc. Temp. Neferirkarē or later.

Mother (from blocks with offering-list), Renpetnefert . Wife (from false-doors), Iḥat , Prophetess of Hathor, etc.

Two false-doors, in Cairo Museum.



(a) CG 1414, BORCHARDT, *Denkmäler*, i, Bl. 19, pp. 80-4; id. *Works of Art*, pl. 21; CAPART, *L'Art ég.* (1909), pl. 27; VANDIER, *Manuel*, ii, fig. 280 [upper right]. Bottom of left jambs, VON BISSING, *Äg. Kunstgeschichte*, Taf. lxix [414]; incomplete, PETRIE Gīza photos. 544-5. Bottom of left inner jamb, VON BISSING in *Ä.Z.* xxxvii (1899), fig. on p. 75; wife and daughter, WENIG, *Die Frau*, pl. 12. Left outer jamb, upper part of wife and her mother Hetepheres embracing, SPIEGEL, *Hochkultur*, Taf. 51 [upper]; female harpist and singer, SACHS in *Der Alte Orient*, 21 [3/4] (1920), Abb. 16, p. 10; SPIEGEL, op. cit. Taf. 51 [lower]; HICKMANN, *Ägypten*, Abb. 116; id. *45 Siècles*, pl. lxii [B]; id. in *Cahiers d'Hist. Ég. Sér. vi* [5, 6] (1954), fig. 1, p. 258; BRUNNER-TRAUT, *Die Alten Ägypter*, Taf. 31a. Wife and son on right outer jamb, FORMAN (W. and B.) and VILÍMKOVÁ, *Eg. Art*, pl. 23; *Egyptian Mythology*, fig. on p. 29. Names and titles, LIEBLEIN, *Dict.* No. 1376. See MASPERO, *Guide*, p. 71 [156].

(b) CG 1416, BORCHARDT, *Denkmäler*, i, Bl. 20, pp. 87-9; VANDIER, *Manuel*, ii, fig. 279 [upper middle], p. 411. See MASPERO, *Guide*, p. 28 [43].

Large offering-list with deceased seated on each side, in Vaucelles Collection (Château de Lignou). DU BOURGUET in *Mélanges Maspero*, i [4], pls. i-v, pp. 11-16; NESTOR L'HÔTE MSS. 20414, 6th carton, X (drawing).

SĀNKHENPTAḤ  PTAḤSHEPSES, Director of *nšd-ms* metal-workers of the Great House. Dyn. VI.

False-door, in Cairo Mus. CG 1445. Texts, BORCHARDT, *Denkmäler*, i, pp. 128-9.
Ointment-slab, alabaster, in Cairo Mus. CG 1339. Id. ib. Bl. 6, p. 19.

SENIMEN  Director of the dining hall, Steward of the Greatest of the directors of craftsmen Raʿneferefʿankh  , etc. Temp. Raʿneferef or later.

False-door, in Cairo Mus. CG. 1410. Texts, BORCHARDT, *Denkmäler*, i, pp. 74-5. Some names and titles, LIEBLEIN, *Dict.* No. 1382.

Offering-table. Text, MARIETTE, *Mastabas*, p. 442 [0].

SETHU  Greatest of the directors of craftsmen, etc. Probably Dyn. V.

Double-stature, deceased seated, with wife kneeling, in Cairo Mus. CG 190. BORCHARDT, *Statuen*, i, Bl. 40, p. 130; HORNEMANN, *Types*, v, pl. 1183.

Offering-stand, in Cairo Mus. CG 1300. BORCHARDT, *Denkmäler*, i, Bl. 1, p. 3; MARIETTE, *Album du Musée de Boulaq* (1872), on pl. 11.



SHEPSES  Overseer of the Great Estate, Overseer of hairdressers of the Great House, etc. Probably Dyn. VI.

Wife (probably), Nefertemʿah , Prophetess of Ḥathor in all her places, etc.
From 'Abûšîr' 1945-6.

Cairo Museum.

Statue of deceased seated, headless, with son censuring and female offering-bringer in relief on side of seat, JE 89378. Offering-table of deceased and wife, JE 89379. Offering-basin of wife, JE 89380.

Perhaps from here.

Double-stature of man and woman, JE 89384, and statue of man sifting flour(?), JE 89385. Offering-basin of Shepeskau , Royal acquaintance, JE 89381, and offering-table of Khenut , Prophetess of Ḥathor, etc., JE 89382. Mummy-mask, plaster, JE 89386.

TEPEMʿANKH  Overseer of the Two Canals of the Great House, Overseer of the department of tenants of the Great House, etc. End of Dyn. V or early Dyn. VI.

False-door, in Copenhagen, Ny Carlsberg Glypt. Æ.I.N. 1438. KOEFOED-PETERSEN, *Cat. des bas-reliefs*, pl. xxiii, pp. 23-4 [16] (as 1437), 71; texts, id. *Rec. inscr.* p. 35.

Blocks in Louvre. See VANDIER, *Guide* (1973), p. 15.

Deceased at table, with offering-list above and sons as priests kneeling, E.25408. Id. in *La Revue du Louvre*, xvii (1967), fig. 4, p. 302; *Vingt ans*, p. 20 [Cat. 74] with pl. (called 79).

Deceased and wife seated receiving lotus-flower from four sons, E.11161. Deceased and wife, BAKER, *Furniture*, fig. 41, p. 50. See BOREUX, *Guide*, i, pp. 248-9; VANDIER, *Guide* (1948 and 1952), p. 9.

THAU , Overseer of tenants of the Great House, etc. Dyn. VI.

Statue, deceased squatting with one knee up, schist, in Cairo Mus. CG 120. BORCHARDT, *Statuen*, i, Bl. 27, p. 92; Brussels. 5000 ans, fig. 13, p. 23 [15]; Louisiana. 5000 års, No. 66 with fig.; HORNEMANN, *Types*, ii, pl. 522. See Vienna. 5000 Jahre, No. 51.

Head-rest, alabaster, in Cairo Mus. CG 1797. BORCHARDT, *Denkmäler*, ii, Bl. 116, p. 216.

WERIRNIPTAH , Prophet of Rē and Ḥathor in the Sun-temple of Neferirkarē, Judge and Overseer of scribes, etc. Temp. Neferirkarē or later.

Plan LXVI.

Wife, Khentkaus , Royal acquaintance.

Chapel. In Brit. Mus. 718.

See *Hiero. Texts*, i², pp. 28-9, with plan, fig. 3; *Guide (Sculpture)*, pp. 24-5 [80].

(1) Doorway. (a)-(b) Lintel with offering-texts, drum (now lost) with titles, and jambs (now lost) with deceased.

Lintel, *Hiero. Texts*, i, pl. 30 [upper]; i², pl. xxix [1], p. 31; vi, pl. 1 [left and middle]. Drum, ib. vi, pl. 1 [right].

(2) Upper part, registers I-III, deceased receiving list, with [attendants] and men arranging chair behind him, and registers before him, I-II, scribes, with herdsmen rendering accounts and bringing animals (almost completely lost in I), III, sowing, sheep treading grain, and men netting fowl. Lower part, IV, left, men preparing bed, right, flax-harvest and reaping corn, V, left, offerings, right, donkeys transporting produce, and men piling up sheaves, VI (now almost completely lost), [sailing-boats].

Ib. vi, pls. 10-12 [upper]; i², pl. xxix [2], pp. 31-2. Deceased and left part of IV-V, WRESZ., *Atlas*, iii. 13. Incomplete right part of IV and V, WILKINSON (A.) in FRANCIS, *Treasures of the British Museum*, fig. 45.

(3) Deceased seated, with offerings before him, and two registers of men bringing offerings, fowl and animals below.

Hiero. Texts, vi, pl. 9; i², pl. xxx, p. 32.

(4)-(7) At top, lintel with offering-texts. (4) Deceased seated and wife squatting, with offerings before and below them, and offering-bringers and butchers. (5) False-door. (6) Deceased and wife seated, with offerings, and registers below, I-II, children, musicians, and singers, III, female clappers and dancers, IV, offering-bringers, V, butchers. (7) False-door of wife.

Ib. i², pl. xxviii, pp. 29-31; vi, pls. 2-8. Lintel and false-doors, ib. i, pls. 30 [lower], 31-2. (5) Lower part, *Guide (Sculpture)*, pl. iii; *Wall Decorations of Egyptian Tombs . . . British Museum*, fig. 4, pp. 5-6; upper part of deceased on jambs, PIJÓN, *Summa Artis*, iii (1945), figs. 235-6. (6) I-V, *Guide, Eg. Collns.* (1909), pl. ix; (1930), fig. 51; I-III, PEET in HAMMERTON, *Universal History of the World*, i, fig. on p. 499 [upper]; HICKMANN in

Ä.Z. 83 (1958), Taf. x [a], pp. 107, 113; id. *Ägypten*, Abb. 56; id. *45 Siècles*, pl. lxxxiv [B]; **II-III**, ANDERSON, *Musical Instruments (Cat. Brit. Mus.)*, fig. 7; **V**, RAGAI, *L'Art*, pl. v [B].

(8) Remains of netting fish (now lost). *Hiero. Texts*, vi, pl. 12 [lower].

Finds

Statue of deceased seated, in Cairo Mus. CG 25. BORCHARDT, *Statuen*, i, Bl. 7, p. 26; HORNEMANN, *Types*, iii, pl. 704.

ZEFANESUT , Recruit. Dyn. III.

Monuments, formerly in von Bissing Colln. and The Hague, Scheurleer Mus., now in Hanover Mus. (a) Niche-stela, No. 1935.200.46; VON BISSING, *Denkmäler*, i, Taf. 14; id. *Äg. Kunstgeschichte*, Taf. lvii [363], *Text*, i, pp. 43, 68 note 2; *Führer durch das Kestner-Museum* (1952), fig. on p. 11 [upper]; WOLDERING, *Ausgewählte Werke der aegyptischen Sammlung* (1955 and 1958), pl. 12; id. *Meisterwerke des Kestner-Museums zu Hannover* (1961), Abb. 4; id. *Götter*, Abb. 17; GALASSI in *Critica d'Arte*, n.s. ii (1955), fig. 243, pp. 305-6; SÉE, *Naissance*, fig. on p. 184 [upper]; MUNRO in *Städel-Jahrbuch*, n.f. 3 (1971), p. 22 [9] with fig. on p. 20; see SMITH (W. S.) in REISNER, *Tomb Development*, p. 398. (b) and (c) Two drums, Nos. 1935.200.45, 47.



(b) MIDDLE KINGDOM

HĒPI , Steward, Inspector of prophets of the Pyramid of Teti, etc. Dyn. XII.

Father, Shedi .

False-door, in Cairo Mus. CG 1409. BORCHARDT, *Denkmäler*, i, Bl. 18, pp. 72-3; VANDIER, *Mamel*, ii, fig. 277 [lower left]. Some texts, DE ROUGÉ, *Inscr. hiéro.* pl. iii [top and upper middle]. Names and titles, LIEBLEIN, *Dict.* Nos. 32-3.

Side-pieces, formerly in Athanasi Colln., now in Berlin (East) Mus. 1118-19, **I**, offering-list, **II**, deceased at table, **III**, deceased in canoe, fowling at No. 1118, and spearing fish at No. 1119, **IV-VI**, offering-bringers. No. 1118, **III**, *Aeg. und Vorderasiat. Altertümer*, Taf. 96 [right]; KLEBS, *Reliefs . . . m.R.* Abb. 36; WRESZ., *Atlas*, iii, Textabb. 106,1 on p. 241; NEUBURGER, *The Technical Arts and Sciences of the Ancients*, fig. 647. No. 1119, **II**, **III**, **V**, **VI**, *Aeg. und Vorderasiat. Altertümer*, Taf. 96 [left], 97; **II**, KLEBS, op. cit. Abb. 123; **III**, id. ib. Abb. 37; id. *Reliefs . . . a.R.* Abb. 23; id. in *Ä.Z.* 52 (1914), Abb. 3, p. 23; SCHÄFER, *Von äg. Kunst* (1919), Taf. 26 [1]; (1922 and 1930), Taf. 22 [1]; (1963), Taf. 23 [1]; Eng. ed. *Principles of Egyptian Art*, pl. 38; GALASSI in *Critica d'Arte*, n.s. ii (1955), fig. 265 [left], p. 316; WRESZ., *Atlas*, iii, Textabb. 105,3 on p. 237; TOUNY and WENIG, *Sport*, Taf. 52; **V-VI**, KLEBS, *Reliefs . . . m.R.* Abb. 131; GALASSI, op. cit. fig. 265 [right], p. 316. Texts, *Aeg. Inscr.* i, pp. 156-9. See *Sotheby Sale Cat.* (ATHANASI), March 13-20, 1837, No. 447 (as from Abydos); L. D. *Text*, v, p. 394 [447]; *Ausf. Verz.* p. 87; *Führer* (1961), pp. 49, 51.



SI-HATHOR  IPI , Hereditary prince, Count, etc. Early Middle Kingdom.

Perhaps near Teti Pyramid.

Texts of Book of the Dead, Pyramid-texts, and Coffin-texts, on walls of burial chamber and sarcophagus. Texts, GUNN Notebook, 16; Coffin-texts, DE BUCK, *The Egyptian Coffin Texts*, v, vi [Sq2Sq].

(c) NEW KINGDOM

AMENEMÖNET , First chief in Memphis, General of the Lord of the Two Lands, Steward in the Temple of Tuthmosis III, etc. Temp. Haremhab.

Parents, Amenmosi  and Depet . Wife, Takhat .

Fragment of column, deceased kneeling before Hathor Mistress of the Sycamore as Western goddess, formerly in Palagi Colln., now in Bologna, Mus. Civico, 1894. RANKE in *Ä.Z.* 67 (1931), Taf. viii [d], p. 78 [5]; *Pelagio Palagi, artista e collezionista* (Bologna, Museo Civico, April–June 1976), No. 485 with fig.; PETRIE ITAL. photo. 223; GARDINER MSS. photo. 28.414. See KMINÉK-SZEDŁO, *Catalogo di Antichità Egizie*, p. 175 (text); DUCATI, *Guida*, p. 51 [P]; CURTO, *L'Egitto antico* (1961), p. 74 [28].

Offering-bringers, in Boston Mus. 1974.468 (adjoining Copenhagen, Ny Carlsberg Glypt. Æ.I.N. 716). *99th Annual Report 1974–5*, fig. on p. 10 [top right], cf. p. 14.

Lintel, double-scene, deceased kneeling before Atum, Souls of Pe and Nekhen, and baboons adoring, in Cairo Mus. Temp. No. 27.6.24.10. RANKE, op. cit. Taf. viii [a, b], p. 78 [1]; CAIRO, CENTRE OF DOCUMENTATION photo. S.R., Box 122, 9324 [upper].

Block, *recto*, heads of deceased and wife, *verso*, deceased adoring Osiris, and another, deceased with wife seated, in Copenhagen, Ny Carlsberg Glypt. Æ.I.N. 714–15. MOGENSEN, *Coll. ég.* pl. cviii [A 731–2], pp. 100–1; BOTTI in *Ä.Z.* 90 (1963), Taf. ii, iii, p. 12; KOEFOED-PETERSEN, *Cat. des bas-reliefs*, pls. xxxviii, xxxix, pp. 36–7 [39], cf. 73; texts, id. *Rec. inscr.* p. 79 [714, 715 (as 815)]; of *recto*, Æ.I.N. 714, L. D. iii. 29 [e], and *Text*, i, p. 138; see RANKE, op. cit. p. 78 [2, 3] (titles); SCHMIDT, *Den Æg. Sam.* (1899), pp. 120–3 [A.89, 90]; (1908), pp. 162–5 [E.98, 99].

Offering-bringers, in Copenhagen, Ny Carlsberg Glypt. Æ.I.N. 716 (adjoining Boston Mus. 1974.468). MOGENSEN, op. cit. pl. cv [A 714], p. 97; KOEFOED-PETERSEN, *Cat. des bas-reliefs*, pl. liii, p. 43 [52]; id. *Ægyptisk Billedhuggerkunst* (1951), pl. 33; id. *Eg. Sculpture* (1951 and 1962), pl. 39; SCHMIDT, *Choix* (1910), pl. xix [47], p. 33. See id. *Den Æg. Sam.* (1908), pp. 166–7 [E.102].

Deceased kneeling adoring, in Heidelberg, Äg. Inst. 559. RANKE, op. cit. Taf. viii [c], p. 78 [4]; OTTO, *Aus der Sammlung des Ägyptologischen Institutes der Universität Heidelberg*, Abb. 17, pp. 93–4 (as 599); MARBURG INST. photo. 620978.

Deceased adoring, in Fundação Calouste Gulbenkian, Lisbon, Inv.205. *Gulbenkian Temporary Exhib. Brit. Mus.* (1937), pl. xx, p. 10; *Egyptian Sculpture from the Gulbenkian Colln.* (1949), fig. on p. 55, cf. p. 22 [14]. See *Museu Calouste Gulbenkian Roteiro*, 1 (1969), No. 15.

Upper part of father and mother, in Louvre, B 6. CAPART, *Documents*, i, pl. 59; id. *L'Art ég.* iii, pl. 573 (cast); RANKE, *The Art of Ancient Egypt*, col. pl. facing pl. 236, and BREASTED, *Geschichte Aegyptens* (1936), pl. facing p. 208; VANDIER, *Guide* (1948), pl. x [1], pp. 41–2; (1952), pl. x [1], p. 42; (1973), pl. xi [1], p. 81; id. in *Musées de France*, April 1948, fig. 1, p. 49; id. and SOUGEZ, *La Sculpture égyptienne au Musée du Louvre*, 15th pl.; DESROCHES NOBLECOURT, *Ancient Egypt* [etc.], pls. 4, 5; HARRIS, *Egyptian Art*, pl. 40; DU BOURGUET,

L'Art égyptien, fig. 37; DEVÉRIA squeezes, 6169, ii. 59; ARCHIVES phot. E. 1183. Text, PIERRET, *Rec. inscr.* ii, p. 6. See DE ROUGÉ, *Notice des monuments* (1883), p. 56; BOREUX, *Guide*, ii, p. 476.

Takha(t) (probably wife) seated by legs of man, in Louvre, B 8. *Encycl. phot. Louvre*, i, pl. 86; ARCHIVES phot. E.1182; VANDIER, *Guide* (1973), pl. xi [2], p. 28. Takha(t), id. ib. (1948 and 1952), pl. x [2], p. 18; CAPART, *Documents*, i, pl. 60; PIRENNE, *Hist. civ.* ii, pl. 83 facing p. 365; VERCOUTTER in GRIMAL, *Histoire mondiale de la femme. Préhistoire et antiquité*, pl. facing p. 112 [right lower]. Text, PIERRET, *Rec. inscr.* ii, p. 20. See DE ROUGÉ, *Notice des monuments* (1883), p. 58; BOREUX, *Guide*, i, p. 61.



Deceased and mother seated, in Paris, Musée Rodin, 237. *Rodin collectionneur. Musée Rodin, Paris, 1967-1968*, No. 51 with col. pl. i.

Deceased (name lost) as fan-bearer, in Parma, Museo Nazionale di Antichità, E.108. CURTO, *L'Egitto antico* (1961), Tav. 19 and front cover, p. 74 [29]; BOTTI in *A.Z.* 90 (1963), Taf. i, pp. 10-13; id. *I Cimeli egizi del Museo di Antichità di Parma*, Tav. xv, pp. 59-63; YOYOTTE, *Treasures*, pl. on p. 133.

Deceased and family punted in marsh-scene, in Strasbourg, Univ. Inst. d'Égyptologie, 2439A. *Antiquités égyptiennes* (Strasbourg, Exposition . . . 12 juillet-15 octobre 1973), fig. 19. See BUCHER and LECLANT in *Bulletin. Société Académique du Bas-Rhin*, n.s. lvii-lx (1953-6), p. 105.

Deceased kneeling adoring hawk-headed god seated, in Hanes Collection, Winston-Salem (N. Carolina).

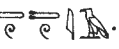
AMENHOTP  HUY , Chief steward in Memphis, etc. Temp. Amenophis III.

Parents, Heby  and Thuthuia . Wife, May , Songstress of Amūn, etc.

List of monuments, HAYES in *J.E.A.* 24 (1938), pp. 10-12 (with bibliography), cf. 16-24.

Pyramidia, granite. (a) Florence Mus. 2610; SCHIAPARELLI, *Il significato simbolico delle Piramidi Egiziane in Reale Accademia dei Lincei, Atti*, Classe di scienze morali [etc.], *Memorie*, 3 Ser. xii (1884), pl. [2], p. 126 [top] (part of text); text, id. *Mus. Arch. Firenze*, p. 420 [1675]; HELCK, *Urk.* iv. 1810-11 [653], cf. *Übersetz.* (1961), p. 268; see MIGLIARINI, *Indication*, p. 70. (b) Leyden Mus. Inv.AM.6; LEEMANS, *Aeg. Mon.* iii, K.1, pls. i, ii; BAGNANI in *Aegyptus*, xiv (1934), fig. 6, p. 46; text, BOESER, *Beschreibung*, v, p. 1 [1]; titles, HELCK, *Urk.* iv. 1811-12 [655], cf. *Übersetz.* (1961), p. 268; see LEEMANS, *Descr. rais.* pp. 137-8 [K.1]; BOESER, *Cat.* (1907), p. 58 [36].

Stela, two registers, I, deceased before Osiris and Ptaḥ, II, wife before Isis and Hathor-cow, quartzite, re-used in Monastery of Apa Jeremias. QUIBELL, *Sagqara (1908-10)*, pl. lxxxiv, p. 146; BAGNANI, op. cit. figs. 8, 9, p. 46; names and titles, HELCK, *Urk.* iv. 1810 [652,A], cf. *Übersetz.* (1961), p. 267. See BOGOSLOVSKAYA in *Tutankhamon i ego vremya* (1976), pp. 61-4, cf. fig. on p. 63 (reversed).

Stela dedicated by son Ipy, in Florence Mus. 2567. MINTO, *Il Regio Museo Archeologico di Firenze*, fig. on p. 25 [upper left]; BOSTICCO, *Le stele egiziane del Nuovo Regno*, fig. 32, pp. 38-9; BAGNANI, op. cit. fig. 1, pp. 33-8; ALINARI photo. 45695; PETRIE ITAL. photo. 245; text, PIEHL in *Rec. Trav.* ii (1880), pp. 124-5 [23]; SCHIAPARELLI, *Mus. Arch. Firenze*, pp. 349-51 [1617]; BEREND, *Principaux monuments*, pp. 71-2; HELCK, *Urk.* iv. 1807-8 [648], cf.

Übersetz. (1961), pp. 265–6; SEYFFARTH MSS. iii. 3165; names and titles, LIEBLEIN, *Dict.* No. 652; see MIGLIARINI, *Indication*, pp. 27–8.

Canopic-chest, quartzite, in Leyden Mus. Inv.AM.2. BOESER, *Beschreibung*, v, Taf. ii, pp. 2–4 [5] (as granite); BAGNANI, op. cit. fig. 7, p. 46 (as granite); name and titles, HELCK, *Urk.* iv. 1810 [652,D], cf. *Übersetz.* (1961), p. 268; see LEEMANS, *Descr. rais.* p. 221 [S.1]; BOESER, *Cat.* (1907), p. 58 [37] (as granite).

Statuette of deceased grinding corn, in Cairo Mus. CG 763. BORCHARDT, *Statuen*, iii, Bl. 141, pp. 78–9. Text, CAPART, *À propos des statuettes de meuniers* in *Transactions of the third International Congress of the History of Religions* (Oxford, 1908), i, p. 202 [7]; HELCK, *Urk.* iv. 1811 [654], cf. *Übersetz.* (1961), p. 268. See BREASTED (Jr.), *Eg. Servant Statues*, pp. 23–4 [6].



Ushabti-coffin, in Leningrad, State Hermitage Mus. 999. BOGOSLOVSKIY in *Vestnik drevney istorii*, 1974, No. 2 (128), fig. 2, pp. 87–9 with note 5; see GOLÉNISCHEFF, *Inventaire de la collection égyptienne* (1891), p. 144.

Two alabaster jars, in Florence Mus. 2338–9. BAGNANI, op. cit. figs. 3, 4, p. 40; PETRIE ITAL. photo. 189; texts, HELCK, *Urk.* iv. 1810 [652,B], cf. *Übersetz.* (1961), p. 267.

Model palettes, alabaster. (a) Florence Mus. 3080; ROSELLINI, *Mon. Civ.* lxvi [4]; CHAMP., *Mon.* cccxxxiii [lower near left]; BAGNANI, op. cit. fig. 2, pp. 38–40; PETRIE ITAL. photo. 355 [lower]; text, HELCK, *Urk.* iv. 1808 [649], cf. *Übersetz.* (1961), p. 266; see MIGLIARINI, *Indication*, p. 91. (b) Louvre, A.F.483; text, PIERRET, *Rec. inscr.* i, p. 92; see BOREUX, *Guide*, ii, p. 610; CHAMPOLLION, *Notice descriptive des monuments égyptiens du Musée Charles X* (1827), p. 102 [M.51]. (c) New York, M.M.A. 37.2.1; *Christie Sale Cat.* (March 2, 1937), No. 47 with pl.; W. C. H[AYES] in *M.M.A. Bull.* xxxii (1937), pp. 157–8 with fig.; id. in *J.E.A.* 24 (1938), pl. i [2], pp. 9–10 [A]; text, HELCK, *Urk.* iv. 1809 [651], cf. *Übersetz.* (1961), p. 267.

Cubit-measure, alabaster, in Florence Mus. 3078. SAIGEY, *Traité de métrologie* [etc.] (1834), pl. 1 [2], pp. 12–13 (text incomplete); VALERIANI and SEGATO, *Atlante Monumentale* [etc.], i (1837), Tav. 37H [1]; LEPSIUS, *Die alt-aegyptische Elle und ihre Eintheilung* (repr. from *Abhandlungen der Königl. Akademie der Wissenschaften zu Berlin*, 1865), Taf. ii [b], pp. 14–15 [3]; BAGNANI, op. cit. fig. 5, pp. 40–6; text, HELCK, *Urk.* iv. 1809 [650], cf. *Übersetz.* (1961), pp. 266–7; name and titles (inaccurate), BEREND, *Principaux monuments*, p. 72 [top]; see CHAMPOLLION (ed. HARTLEBEN) in *Bibl. Ég.* xxx, pp. 23–4; MIGLIARINI, *Indication*, pp. 90–1.

Chair-leg, wood, in Leyden Mus. Inv.AH.126. LEEMANS, *Aeg. Mon.* ii, H.551, pl. lxxiv; see id. *Descr. rais.* p. 97 [H.551]; BOESER, *Cat.* (1907), p. 175 [3].

ḤORI  , Greatest of the directors of craftsmen, etc. Late Dyn. XIX to early Dyn. XX.

Father, Kha'emwaset (son of Ramesses II).

Pillar with deceased adoring and carrying *zad*-pillar on three faces, in Cairo Mus. JE 43271. QUIBELL, *Saqqara (1908–10)*, pl. lxx [1–3], p. 144.

Almost certainly this man and from here.

Sarcophagus, sandstone, in Berlin (East) Mus. 57. *Ausf. Verz.* Abb. 36, p. 171. Text, *Aeg. Inschr.* ii, pp. 361–7.

Canopic-jars. (a) and (b) Imset and Kēbhsenuf, Brit. Mus. 36530, 36535; WILLIAMS rubbings, iv. 107 [top]; part of text of No. 36530, SETHE, *Zur Geschichte der Einbalsamierung*

[etc.] in *Sitzungsb. Berlin* (1934), p. 10* [XVII, A]. (c) Duamutf, formerly in Anastasi Colln., now in Liège, Musée Curtius, I/635 [Eg.61]; MALAISE, *Antiquités égyptiennes . . . des Musées Curtius et du Verre à Liège*, fig. 18, pp. 51-2 [9] and pl. v [8]; see LENORMANT, *Cat. . . . d'antiquités égyptiennes . . . Anastasi*, Vente, rue de Clichy, Paris, June 23-7, 1857, No. 235.

IPY , Chief steward, Fan-bearer on the right of the King, etc. Probably temp. Tutankhamûn.

Father, Amenhotp Huy (tomb, see *supra*).

See HAYES in *J.E.A.* 24 (1938), p. 24.

Stela, deceased adoring seated Anubis, in Leningrad, State Hermitage Mus. 1072. MAT'É, *Iskusstvo Drevnego Egipta*, iii (1947), pl. xxxv; PAVLOV and MAT'É, *Pamyatniki iskusstva Drevnego Egipta* [etc.], pl. 51; SHURINOVA, *Iskusstvo Drevnego Egipta*, fig. on p. 25; LANDA in *Vestnik drevney istorii*, 1974, No. 2 (128), fig. 1, pp. 97-104; id. and LAPIS, *Egyptian Antiquities in the Hermitage*, pls. 42-3; *Vystavka pamyatnikov, restavrirovannykh v Gosudarstvennom Ermitazhe* (1973), front cover, p. 104 [150]. Text, STRUVE, *Etyudy po istorii Severnogo Prichernomor'ya, Kavkaza i Sredney Azii*, pp. 302 [33], cf. 284; part, LIEBLEIN, *Die aegyptischen Denkmäler* [etc.] (1873), Taf. v [17], p. 27 [45]; HELCK, *Urk.* iv. 1812 [656], cf. *Übersetz.* (1961), p. 269; names and titles, LIEBLEIN, *Dict.* No. 2053. See GOLÉNISCHEFF, *Inventaire de la collection égyptienne* (1891), p. 156.

Two canopic-jars, alabaster, in Leyden Mus. Inv.AAL.4c, d. VAN WIJNGAARDEN, *Beschrijving van de egyptische Verzameling* [etc.], xiii, pl. xi [70-1], pp. 13-14 with figs. 58-61 (text); name and titles, SETHE, *Zur Geschichte der Einbalsamierung* [etc.] in *Sitzungsb. Berlin* (1934), p. 5* [IX, A]; see LEEMANS, *Descr. rais.* p. 216 [R.8, 10]; BOESER, *Cat.* (1907), p. 105 [70-1].

IYIRY , Greatest of the directors of craftsmen, etc. Temp. Sethos II.

Name and titles, DE ROUGÉ, *Inscr. hiéro.* pl. xcvi [lower]. Blocks re-used at Mit Rahîna, see *infra*.

KHA'EMWĒSET , King's son, Greatest of the directors of craftsmen, etc. Temp. Ramesses II.

Parents, Ramesses II and Ēsinefert.

False-door, fragmentary, granite, found in the Serapeum Vaults. GOMAA, *Chaemwese* [etc.], p. 80 [30] with Abb. 9. Text of left part, GUNN MSS. xv. 2. 1-3. See MARIETTE, *Notice des principaux monuments . . . à Boulaq* (1864), pp. 283-4 [29]; LAUER in *Mélanges Mariette*, p. 15 [middle].

Column-fragment with deceased at table, in Cairo Mus. JE 41525. GOMAA, op. cit. p. 82 [41] with Taf. vii.

Block, butchers, formerly in von Bissing Colln., now in Hanover Mus. 1935.200.183. VON BISSING, *Denkmäler*, ii, Taf. 100 [b]; WOLDERING, *Ausgewählte Werke der aegyptischen Sammlung* (1955), pl. 32; (1958), pl. 44. See GOMAA, op. cit. p. 94 [100].

Canopic-jar. Id. ib. Abb. 33a, p. 93 [93].

Found re-used in the Monastery of Apa Jeremias.

Block with offering-text, granite, in Cairo Mus. JE 40016. Text, QUIBELL, *Saqqara* (1907-8), pp. 5, cf. 4 (as basalt). See GOMAA, op. cit. p. 81 [36].

Two joining blocks with remains of text. Text, id. ib. p. 81 [38] with Abb. 14 [b].

MERYMERY , Custodian of the Treasury of Memphis. Probably temp. Amenophis III.

Wife, Meryptah .

In Leyden Museum.

See LEEMANS, *Descr. rais.* pp. 142-4 [K.14, 15], 54 [D.47-9], 210 [P.115]; BOESER, *Cat.* (1907), pp. 63-5 [49, 50], 65 [53-6]. Date, see BOGOSLOVSKAYA in *Tutankhamon i ego vremya* (1976), pp. 54-5, cf. fig. on p. 54.

Side walls, Inv.AP.6. Names and titles, LIEBLEIN, *Dict.* No. 709, *Suppl.* p. 966.

Left, registers, **I**, man censuring and libating before deceased seated, and two sub-registers of offering-bringers, **II**, deceased, list of Opening-the-Mouth requisites before him, and two sub-registers with *sem*-priest and offering-bringers, **III-IV**, funeral procession. Offering-text below.

LEEMANS, *Aeg. Mon.* iii, K.15, pls. xxiii, xxiv; BOESER, *Beschreibung*, iv, Taf. xiii-xv. **I**, SCHÄFER and ANDRAE, *Kunst* (1925), 356; (1930), 372; (1942), 370 (all from BOESER). Lower sub-register of **I**, and upper sub-register of **II**, *Artefact*, pls. 64, 63, p. 38; 2nd to 4th offering-bringers with bull in lower sub-register of **I**, and first three people with gazelle in upper sub-register of **II**, KLASENS, *Egyptische Kunst*, pls. 36-7; 4th offering-bringer carrying crane in lower sub-register of **I**, SCHÜZ, *Über Stelzvögel* [etc.] in *Die Vogelwarte*, 23 (1966), Abb. 14 on p. 277; id. *Vögel der Pharaonen in Vogel-Kosmos*, Heft 11 (Nov. 1967), fig. on p. 373. Head of deceased in **II**, MYŚLIWIEC, *Le Portrait royal dans le bas-relief du Nouvel Empire*, pl. lxii [146] (from BOESER), p. 72. List of Opening-the-Mouth requisites in **II**, OTTO, *Das ägyptische Mundöffnungsritual*, ii, Abb. 14 (from BOESER), pp. 22-6, 181 [75]. **III-IV**, and offering-text below, WOLF, *Kunst*, Abb. 585. **III-IV**, WRESZ., *Atlas*, i. 421; WERBROUCK, *Pleureuses*, pl. xxxvi, p. 89. Men with vases and others carrying chest with canopic-jars in **IV**, MAZAR, *Views*, ii, pl. 25. Texts of mourners in **III-IV**, LÜDDECKENS in *Mitt. Kairo*, 11 (1943), pp. 147-53 [73-5], cf. Abb. 51-2.

Right, registers, **I**, purification of mummy by *sem*-priest before Anubis, and two sub-registers with butcher and offering-bringers before statue, **II**, offering-list, offering-bringers, and priests before deceased and wife seated, **III**, deceased, and two sub-registers of agriculture. Offering-text below.

LEEMANS, *Aeg. Mon.* iii, K.14, pls. xxi, xxii; BOESER, *Beschreibung*, iv, Taf. xvi-xviii. **I**, purification and part of sub-registers, LAGIER, *À travers la Haute Égypte*, fig. 47 facing p. 141; purification, SAUNERON, *Les prêtres de l'ancienne Égypte*, fig. on p. 107. Deceased and wife in **II**, *Artefact*, pl. 62, p. 38; KLASENS, *Egyptische kunst*, pl. 35. **III**, and offering-text below, WOLF, *Kunst*, Abb. 586. **III**, WRESZ., *Atlas*, i. 422. Lower sub-register of **III** and part of text below, DE BUCK, *Egyptische Verhalen*, pl. facing p. 80; right group of men ploughing, SCHÄFER, *Principles of Egyptian Art*, pl. 46.

Statuettes.

Three, man grinding corn, inscribed, two of them sandstone, one limestone, Inv.AST.30a, 30b, 52. BOESER, *Beschreibung*, iv, Taf. xx [k, l, i]; CAPART, *Recueil*, ii, pl. lxxix; HORNE-MANN, *Types*, ii, pls. 548, 546; iii, pl. 804. Inv.AST.30a, 52, LEEMANS, *Aeg. Mon.* ii, pl. xii [47-8]. Inv.AST.52, see BREASTED (Jr.), *Eg. Servant Statues*, p. 23 [3]. See BOESER, *Cat.* (1907), p. 65 [54-6].

Mummy on couch, with woman standing at its feet, inscribed with Chapter 6 of Book of the Dead, sandstone, Inv.L.VII.14. Id. *Beschreibung*, iv, Taf. xx [h]; SPELEERS, *Les figures funéraires égyptiennes*, pls. 36, cf. 37 [lower]; HORNEMANN, *Types*, v, pl. 1219.

MERYPTAH , Greatest of the directors of craftsmen, etc. Probably temp. Haremhab.

Block, deceased sowing, and two sub-registers of hacking ground and ploughing, in Karlsruhe, Badisches Landesmuseum, H.1046. WIEDEMANN and PÖRTNER, *Aegyptische Grabreliefs aus der Grossherzoglichen Altertümer-Sammlung zu Karlsruhe*, Taf. vii, p. 32.

Lower part of statue of deceased kneeling with naos of Osiris, sandstone, probably from here, in Louvre, A 60. Part of text, REVILLOUT in *Revue Égyptologique*, iii (1885), p. 12 note 2; see DE ROUGÉ, *Notice des monuments* (1883), p. 34; BOREUX, *Guide*, i, p. 54.

Offering-table, in Berlin (East) Mus. 2273. *Aeg. und Vorderasiat. Altertümer*, Taf. 57 [lower left]; *Ausf. Verz.* Abb. 35, p. 169; ERMAN, *Die ägyptische Religion* (1905), fig. 79; (1909), fig. 83; id. *Die Religion der Ägypter*, fig. 91; SCHÄFER and ANDRAE, *Kunst* (1925), 400 [lower]; (1930 and 1942), 416 [right]; JOLLES in *Jahrbuch des Kaiserlich Deutschen Archäologischen Instituts*, xxiii (1908), Abb. 50, p. 248; BONNET, *Reallexikon der ägyptischen Religionsgeschichte*, Abb. 137; *Budapest. Ägyptische Kunst. Sonderausstellung . . . Museen zu Berlin . . .* 1963, No. 64 with pl. xii [1]; *Gudar och människor vid Nilen* (Göteborg, 18 mars–20 maj 1973), No. 330 with pl. 24; Kunstmuseet i Ateneum Helsingfors. *Det eviga Egypten. Aegyptus aeterna* (1973), No. 77 with fig. 3; Sofia. *Izložbha Vechniyat Egipet* (1975), No. 35 at the beginning with fig. Text, *Aeg. Inschr.* ii, p. 318.

MERYRĒ , Steward, Overseer of nurses of the Good God, etc. Probably temp. Amenophis III.

Wife, Beketamün  Bakt.

Monuments, probably from here, in Vienna, Kunsthistorisches Museum. (a) Stela-fragment, registers, I, deceased and wife before [RĒ-Ḥarakhti-Atum], II, deceased seated with Siatum , King's son, on his knees, with wife, small daughter, and offering-bringers, Inv. 5814. (b) Block, registers, I, deceased and wife before Osiris, II, deceased adoring RĒ-Ḥarakhti, with hymn, Inv. 5815.

Echnaton, Nofretete, Tutanchamun. Ausstellung . . . Wien, 23. April . . . 29. Juni 1975, Nos. 77–8 with figs.; texts, VON BERGMANN in *Rec. Trav.* ix (1887), pp. 46–7 [18, 17]; see *Uebersicht* (1895), p. 36 [81, 76]; (1923), p. 11 [80, 76]. (a) BRUNNER in *Ä.Z.* 86 (1961), Taf. iii, pp. 95–6; some names and titles, LIEBLEIN, *Dict.* No. 2174. (b) Text, WRZESINSKI, *Aegyptische Inschriften aus dem K.K. Hofmuseum in Wien*, pp. 45–50 [i. 17].

NEFERRONPET , Governor of the town, Vizier, Greatest of the directors of craftsmen, etc. Temp. Ramesses II.

Parents, Neferronpet and Kafiriati  = . Wife, Mut-pipu .

Pyramidion, granite, formerly in J. Sams and J. Mayer Collns., now in Liverpool, Merseyside County Museums, M.11015. *Ancient Egypt. Objects . . . in the possession of J. Sams* (1839), 1st pl. Text, EDWARDS (A. B.) in *Rec. Trav.* x (1888), pp. 130–1 [iii]. Names and titles, LIEBLEIN, *Dict.* No. 1068. See GATTY, *Catalogue of the Mayer Collection*, Pt. 1

(1877), p. 29 [151]; (1879), p. 33 [151]; *Handbook and Guide to the Egyptian Collection* (1932), p. 39 [lower, 13].

Statues. See CHRISTOPHE in *Bull. Inst. Ég.* xxxvii [1] (1954-5), pp. 28-30 [Doc. 3].

Block-statue, diorite, in Cairo Mus. CG 713. BORCHARDT, *Statuen*, iii, Bl. 132, pp. 50-1.

Block-statue, with naos of Ptah, granite, in Cairo Mus. CG 1034. Text, id. ib. iv, p. 33.

Kneeling statue with naos of Osiris, with cartouches of Ramesses IV, granite, in Leyden Mus. Inv.AST.16. LEEMANS, *Aeg. Mon.* ii, pl. xi [442]. Text, BOESER, *Beschreibung*, v, pp. 7-8 [18] with figs. 34-7. Cartouches, CHRISTOPHE in *Bull. Inst. Ég.* xxxvii [1] (1954-5), p. 24 [6]. See LEEMANS, *Descr. rais.* p. 53 [D.44]; BOESER, *Cat.* p. 69 [95].

NIA , Chief steward, Overseer of the cattle of Amūn, etc. End of Dyn. XVIII or early Dyn. XIX.

Wife, Iuy , Songstress of Amūn, etc.

Pyramidion, granite, in Louvre, D 14 [N.355]. PERROT and CHIPIEZ, *Hist. de l'Art*, i, fig. 154; HAY MSS. 29844 A, 46 (including statue of deceased); see DE ROUGÉ, *Notice des monuments* (1883), pp. 185-6; BOREUX, *Guide*, i, p. 120; VANDIER, *Guide* (1948), p. 23; (1952), p. 24; (1973), p. 37.

Stela, deceased before Rē-Ḥarakhti and Atum in double-scene at top, in Cairo Mus. JE 10079. MARIETTE, *Mon. div.* pl. 57 [a]; text, DE ROUGÉ, *Inscr. hiéro.* pls. xli, xlii; PIEHL in *Rec. Trav.* ii (1880), p. 72; VASSALLI MSS. 20 [left].

Two papyrus-columns, inscribed on abaci, in Berlin (East) Mus. 1627-8. *Aeg. und Vorderasiat. Alterthümer*, Taf. 117; texts, *Aeg. Inschr.* ii, pp. 398-9; see *Ausf. Verz.* p. 146; *Führer* (1961), p. 70.

Anthropoid sarcophagus, granite, in Louvre, D 2 [N.338]. PERROT and CHIPIEZ, op. cit. fig. 195; SCHMIDT, *Levende og Døde*, figs. 649-50; text, PIERRET, *Rec. inscr.* ii, p. 18; see DE ROUGÉ, *Notice des monuments* (1883), p. 176; BOREUX, *Guide*, i, p. 114; VANDIER, *Guide* (1948 and 1952), p. 20; (1973), p. 35.

Left part of lintel, deceased and wife kneeling adoring Osiris and Isis, with Osiris and Nephthys from another scene on right, in Chicago, formerly Art Institute 94.246, now Or. Inst. 17300. ALLEN, *A Handbook of the Egyptian Collection* (1923), pp. 41-2 with fig.

Blocks, in Cairo Mus. Deceased supervising unloading boats, Temp. No. 25.6.24.7; VON BISSING, *Die Kultur des alten Ägyptens*, Taf. 10 [21]; DARESSY in *R.E.A.* iii (1931), fig. 6, pp. 33-5; GRIFFITH INST. photo. 362; omitting deceased, LANDSTRÖM, *Ships of the Pharaohs*, fig. 403, pp. 138-9; see MASPERO, *Guide*, p. 180 [652, B]. Deceased seated, with monkey under chair, and two registers with scribe in each, I, storing wine, II, officials, Temp. No. 3.7.24.13; GRIFFITH INST. photo. 363; monkey, VANDIER D'ABBADIE in *Rev. d'Ég.* 18 (1966), fig. 37, pp. 176-8; scribe and two men pouring wine in I, FORMAN (W. and B.) and VILÍMKOVÁ, *Eg. Art*, pls. 78, 87; see MASPERO, *Guide*, p. 180 [651, B]. Wife offering bouquet to deceased, Temp. No. 14.6.24.29; ROEDER in *Ä.Z.* 83 (1958), Taf. vi [c], p. 57 [4]; Louisiana. 5000 års, No. 160 with fig.; Brussels. 5000 ans, fig. 35, p. 27 [44]; Vienna. 5000 Jahre, No. 110 with Abb.; Essen. 5000 Jahre, No. 108 with Abb.



NIAY , Royal scribe, Prophet of Sekhmet in the Temple of Sekhmet. Dyn. XIX.

Deceased kneeling before date-palm in tree-goddess scene (no goddess), with *bas* drinking, in Berlin (East) Mus. 7322. OHNEFALSCH-RICHTER, *Kypros*, pl. xxxix [1]; BORCHARDT, *Die*

Aegyptische Pflanzensäule, Abb. 72, cf. 72a; KEIMER in *Ann. Serv.* xxix (1929), fig. 2, p. 84; CRAMER in *A.Z.* 72 (1936), Taf. vii [2], pp. 92-4; text, WIEDEMANN in *Rec. Trav.* xvii (1895), p. 10; *Aeg. Inschr.* ii, p. 202; name and titles, *L. D. Text*, i, p. 138; see *Ausf. Verz.* p. 150.

Deceased and wife kneeling before tree-goddess in sycamore, with *bas*, in Hanover Mus. 2933. *Führer des Kestner-Museums in Hannover*, i, *Altertum* (1900), fig. 2 on p. 24; *Führer* (1952), fig. on p. 14 [lower left]; VON BISSING in *Münchener Jahrb.* n.f. i (1924), Abb. 1, p. 211; CRAMER, op. cit. Taf. vii [1], pp. 92-4; *Schaetze altaegyptischer Kunst. Kunsthalle, Basel*, 27. Juni-13. Sept. 1953, 20th Abb., p. 58 [153]; WOLDERING, *Ausgewählte Werke der aegyptischen Sammlung* (1955), pl. 30; (1958), pl. 36; id. *Meisterwerke des Kestner-Museums zu Hannover* (1961), Abb. 19; id. *Götter*, Abb. 90; KEIMER in *Egypt Trav. Mag.* No. 29 (Jan. 1957), fig. 5 on p. 23; MUNRO in *Städel-Jahrbuch*, n.f. 3 (1971), p. 28 [23] with fig. on p. 29; *Echnaton, Nofretete, Tutanchamun*. Ausstellung . . . Hildesheim, 15. Juli-26. September 1976, No. 100; without text, WILKINSON MSS. ix. 175 [upper]; sycamore, KEIMER in *Ann. Serv.* xxix (1929), fig. 1, p. 84; text, WIEDEMANN, op. cit. p. 10; see *Führer* (1891), p. 12 [17].

PAGERGER , Head of chisellers. Dyn. XIX.

Father, Gegerem . Wife, Nezem(t)-mennüfer .



Pyramidion, probably from here, in Louvre, D 44 [N.363]. ARCHIVES phot. E.810. See DE ROUGÉ, *Notice des monuments* (1883), pp. 205-6.

Column-bases. (a) Berlin (East) Mus. 2286 (from Passalacqua Colln.); text, *Aeg. Inschr.* ii, p. 314; see PASSALACQUA, *Cat. raisonné*, p. 109 [1585]; *Ausf. Verz.* pp. 146-7. (b) Leyden Mus. Inv.L.XI.7; LEEMANS, *Aeg. Mon.* iii, K.8, pl. xvi; BOESER, *Beschreibung*, iv, Taf. xxxvii [8], and fig. 10 on p. 10; see id. *Cat.* (1907), p. 69 [92]; LEEMANS, *Descr. rais.* p. 141 [K.8].

Niches with statues. (a) Copenhagen, Thorwaldsen Mus. 349; KOEFOED-PETERSEN in *Archiv Orientalní*, xx (1952), pl. xlv, pp. 432-3; text, MADSEN in *Sphinx*, xiii (1910), pp. 52-3; PIEHL, *Inscr. hiéro.* 1 Sér. xci [H]; see MÜLLER (L.), *Description des antiquités du Musée-Thorwaldsen* (1847), Section i, p. 32. (b)-(e) Leyden, Inv.AM.14a, 15-17; BOESER, *Beschreibung*, v, Taf. xiv; texts of two, PIEHL, op. cit. 3 Sér. xxxv-xxxvi [P, Q]; name and title, LIEBLEIN, *Dict.* No. 851; see LEEMANS, *Descr. rais.* p. 287 [V. 80-3]; BOESER, *Cat.* (1907), p. 58 [35].

Offering-tables. (a) Copenhagen, Ny Carlsberg Glypt. Æ.I.N. 1554 (formerly in Athanasi, Lee and Amherst Collns.); KOEFOED-PETERSEN, *Cat. des bas-reliefs*, pl. lxxxvi [87], pp. 63, 76; WILLIAMS rubbings, iii. 81 [lower]; text, KOEFOED-PETERSEN, *Rec. inscr.* p. 76; see [BONOMI], *Cat. . . Hartwell House*, pp. 79-80 [556]; *Sotheby Sale Cat.* (ATHANASI), March 13-20, 1837, No. 285; ib. (AMHERST), June 13-17, 1921, No. 234 [3rd item]. (b) Leyden Mus. Inv.AM.14b; BOESER, *Beschreibung*, v, Taf. iii [7]; see id. *Cat.* (1907), p. 69 [88]; LEEMANS, *Descr. rais.* pp. 44-5 [C.19]. (c) Louvre, D 49 [E.3070]; DEVÉRIA squeezes, 6168, 8; text, PIERRET, *Rec. inscr.* i, p. 81; see DE ROUGÉ, *Notice des monuments* (1883), p. 207; BOREUX, *Guide*, i, p. 188; VANDIER, *Guide* (1948 and 1952), p. 26.

PAHEMNETER , Greatest of the directors of craftsmen, etc. Probably temp. Ramesses II.

Parents, Maḥuy  and Nena  (from Florence Mus. 2607).

Another Pahemneter with the same title is known from the end of the XIXth and the beginning of the XXth Dynasties, and some of the following monuments might belong to him.

Statue in niche, in Cairo Mus. JE 89046, and block with text, LECLANT in *Orientalia*, n.s. 19 (1950), pls. lv [4], lvi [5], p. 492 [b]. Statue, GABALLA in *Mitt. Kairo*, 30 (1974), Taf. 2 [b, c], fig. 6, pp. 21-4. See LAUER in *Bull. Soc. fr. d'Ég.* No. 5 (Dec. 1950), p. 87.

Pillar, deceased carrying *zad*-pillar on faces (a) and (c), and standard of Sekhmet on (b) and (d), in Florence Mus. 2607. MARBURG INST. photos. 628881-2. (a) and (d), HERMANN in *Ä.Z.* 75 (1939), Taf. viii [a], p. 60; ALINARI photo. 31109. Deceased on (b) and (d), PETRIE ITAL. photo. 243. Names and titles, LIEBLEIN, *Dict.* No. 775, *Suppl.* p. 969. See SCHIAPARELLI, *Mus. Arch. Firenze*, pp. 424-7 [1679] (text); ROSELLINI, *Breve Notizia degli Oggetti di Antichità Egiziane* [etc.] (1830), pp. 15-16 [5]; MIGLIARINI, *Indication*, p. 46.

Blocks, probably from Anastasi Collection, now in Stockholm Mus. Lower part of jamb of deceased, man adoring and another censing, added later, MM.32014; PETERSON in *Medelhavsmuseet Bulletin*, 5 (1969), figs. 4, 5, pp. 8-10; see LIEBLEIN, *Katalog öfver egyptiska fornlemningar i National-Museum* (1868), p. 28 [53]. Remains of text mentioning deceased, MM.32015; PETERSON, *op. cit.* fig. 6, p. 10; text, MOGENSEN, *Stèles égyptiennes au Musée National de Stockholm*, p. 64 [54]; see LIEBLEIN, *op. cit.* p. 28 [54]. Another two, possibly belonging, (a) registers, I, [man], and Chapter 125 of Book of the Dead, II, offering-bringers, MM.32011, (b) Chapter 182 of Book of the Dead, and middle part of man, MM. 32013; PETERSON, *op. cit.* figs. 1, 3, pp. 4, 6-8, 12; texts, MOGENSEN, *op. cit.* p. 41, cf. 42, and p. 28, cf. 27; see LIEBLEIN, *op. cit.* pp. 25-6 [38], 25 [37].

Anthropoid sarcophagus, granite, formerly in Anastasi Colln., now in Brit. Mus. 18. *Hiero. Texts*, 9, pls. xvii, xviiA, pp. 21-2; SCHMIDT, *Levende og Døde*, fig. 643. See SHARPE, *Eg. Antiq.* p. 61; *Guide (Sculpture)*, p. 182 [654]; *A Handbook to the Egyptian Mummies* [etc.] (1938), pp. 63-4.



Anthropoid sarcophagus, granite, formerly in Anastasi Colln., now in Berlin (East) Mus. 33. Texts, *Aeg. Inschr.* ii, pp. 374-81; see *Ausf. Verz.* p. 172.

Two canopic-jars, alabaster. (a) Imset, Toulouse, Musée Labit, 49.289; GUILLEVIC and RAMOND, *Musée Georges Labit. Antiquités égyptiennes* (1971), p. 52 with fig. on p. 20 [right]. (b) Hēpy, formerly in Prachov Colln.; text, TURAEV, *Opisanie egipetskikh pamyatnikov v Russkikh muzeyakh i sobraniyakh in Zapiski Vostochnago Otd. Imp. Russk. Arkh. Obshch.* xii, pl. xiv [lower], p. 211 [54].

Two fragments of alabaster palette, formerly in Anastasi Colln., now in Leyden Mus. Inv.AAL.157. See LEEMANS, *Descr. rais.* p. 110 [1.309].

PATENEMḤAB  Royal butler. End of Dyn. XVIII.

Plan LXVI.

Mother(?), Merytptah . Wife, Tipuy  Songstress of Amūn.

Chapel. In Leyden Mus. Inv.AMT.1-35, and AP.52 (stela).

LEEMANS, *Aeg. Mon.* iii, K.4-7, pls. v-xv, with plan, pl. vi [upper]; BOESER, *Beschreibung*, iv, Taf. i-xii, pp. 1-5, with plan on p. 1. Names, LIEBLEIN, *Dict.* No. 854. See LEEMANS, *Descr. rais.* pp. 138-41 [K.4-7]; BOESER, *Cat.* (1907), pp. 60-1 [45].

(1) and (2) Papyrus-columns with texts.

LEEMANS, *Aeg. Mon.* iii, K.4, 5, pl. v; BOESER, *Beschreibung*, iv, Taf. i.

(3) Doorway (upper part lost). (a) Text, and deceased seated, with mother(?) squatting, (b) with wife squatting. (c) A couple before deceased(?), with priest and five offering-bringers below (no texts). (d) Deceased with family, and offering-bringers before couple seated below (no texts).

LEEMANS, *Aeg. Mon.* iii, K.6a, a', b, i, pls. vi [lower], vii, viii; BOESER, *Beschreibung*, iv, Taf. ii-iv. Deceased with family at (d), VAN WIJNGAARDEN, *Meesterwerken*, pl. 53 [lower].

(4) Three registers of scenes of Book of the Dead, including Fields of Iaru.

LEEMANS, *Aeg. Mon.* iii, K.6c, pl. ix; BOESER, *Beschreibung*, iv, Taf. xii. I, omitting gods, BREMMER, *Eg. kunst*, Nos. 15, 19, 23; deceased and wife in canoe, HERMANN in *Jahrbuch für Antike und Christentum*, 7 (1964), Taf. 1 [c], p. 43. II, omitting right end, BREMMER, op. cit. Nos. 18, 22, 24.

(5) (upper part lost) Deceased and wife at table, with two daughters seated under chair of wife, and two registers before them, another couple seated, and priest and offering-bringers.

LEEMANS, *Aeg. Mon.* iii, K.6d, pl. xi; BOESER, *Beschreibung*, iv, Taf. xi. Daughters, VAN WIJNGAARDEN, op. cit. pl. 53 [upper]. Upper part of offering-bringer with lotus, and daughters, BREMMER, op. cit. Nos. 16, 21.

(6) (upper part lost) Two priests before deceased and wife (no texts).

LEEMANS, *Aeg. Mon.* iii, K.6h, pl. x; BOESER, *Beschreibung*, iv, Taf. v.

(7) (upper part lost) Deceased and wife at table, with daughters seated under chair, and before them, priest censing and libating and four musicians, with harpist's song above.¹

LEEMANS, *Aeg. Mon.* iii, K.6g, pl. xii; BOESER, *Beschreibung*, iv, Taf. vi, vii; *Gids* (1926), fig. on p. 78; (1928), fig. on p. 85; (1937), fig. on p. 109. Priest, musicians and song, CAPART, *Recueil*, i, pl. xxxiv; id. *L'Art ég.* iii, pl. 550; BREASTED, *History*, fig. 96; id. *The Dawn of Conscience*, fig. 10 facing p. 164. Priest and musicians, WILKINSON, *M. and C.* ii, 316 (No. 229) = ed. BIRCH, i, 493 (No. 254) (modified); RANKE, *The Art of Ancient Egypt*, and BREASTED, *Geschichte Aegyptens* (1936), 227; ERMAN and RANKE, *Aegypten und aegyptisches Leben im Altertum* (1923), Taf. 32 [1]; BYVANCK, *De Kunst*, pl. lii [178]; MURRAY, *Sculpture*, pl. xxxviii [2]; HICKMANN, *45 Siècles*, pl. lxxxii; id. in *Egypt Trav. Mag.* No. 19 (Feb. 1956), fig. on p. 4; id. in *Ann. Serv.* xlvi (1948), fig. 22, p. 659; id. in *Cahiers d'Hist. Ég. Sér. vi* [5, 6] (1954), fig. 20, p. 299; id. *Ägypten*, Abb. 51; GALASSI in *Critica d'Arte*, n.s. ii (1955), fig. 281 on p. 341; BALODIS, *Ägypten. Pyramidernes og mysteriernes land*, fig. 22; DAUMAS, *Civ. de l'Ég.* pl. 89; VAN WIJNGAARDEN, *Meesterwerken*, pl. 52; *Artefact*, pls. 57-8, pp. 37-8. Upper part of priest, and harpist and flutist, ZADOKS-JOSEPHUS JITTA, *Het Nabije Oosten*, pl. 20; ZANDEE, *De schatten van Egypte*, fig. 45; LANGE and HIRMER, *Aegypten. Architektur* (1957), pls. 196-7; MICHALOWSKI, *Art*, fig. 494; with song above, WOLF, *Die Welt der Ägypter*, Taf. 86 [lower]; KLASENS, *Egyptische kunst*, pls. 40-1. Upper part of priest, and harpist, DESROCHES-NOBLECOURT, *Ancient Egypt* [etc.], pls. 22-3. Musicians, SÄVE-SÖDERBERGH, *Faraoner och människor*, 3rd pl. after p. 40. Harpist and flutist, id. *Pharaohs and Mortals*, pl. on p. 61; *Gids* (1953), fig. 10, and front cover; PIRENNE, *Hist. civ.* ii, pl. 72 facing p. 313; VANDERSLEYEN, *Das Alte Ägypten*, Abb. 298. Blind harpist, BREMMER, *Eg. kunst*, No. 17; LUGN, *Konst*, fig. 67; LANGE and HIRMER, *Ägypten. Architektur* (1967), pl. 210; MURRAY, *Splendour*, pl. lxxiii [2]; DE BUCK, *Egyptische Verhalen*, pl. facing p. 96; LECLANT and RACCAH, *Dans les pas des Pharaons*, fig. on p. 31; MEKHITARIAN, *L'Égypte*, fig. on p. 123; GROLLENBERG, *Atlas de la Bible*, fig. 271; ATARASHI, *Égypte*, pl. 86; WELLS, *Bones, Bodies and Disease*, pl. 6; LECA, *Médecine*, fig. 79; WESTENDORF, *Das Alte Ägypten*, fig. on p. 159;

¹ Selected references.

MICHAŁOWSKI, *Nie tylko piramidy . . .*, pl. 80; BRUNNER-TRAUT, *Die Alten Ägypter*, Taf. 49; SÉE, *Grandes villes*, fig. on p. 57. Harpist's song, MÜLLER (W. M.), *Die Liebespoesie der alten Ägypter*, Taf. 16 [bottom]; mention of Imḥōtep, see WILDUNG, *Imhotep und Amenhotep*, pp. 21–5 [9.1], cf. Taf. ii (from CAPART).

(8) (upper part lost) Deceased and wife before a god, and offering-bringers below (no texts).

LEEMANS, *Aeg. Mon.* iii, K.6e, pl. xiii; BOESER, *Beschreibung*, iv, Taf. x. Offering-bringer with crane and oryx, SCHÜZ, *Über Stelzvögel* [etc.] in *Die Vogelwarte*, 23 (1966), Abb. 13 on p. 277; id. *Vögel der Pharaonen* in *Vogel-Kosmos*, Heft 11 (Nov. 1967), fig. on p. 372.



(9) (upper part lost) Deceased and wife before a god, with priest censuring and libating and offering-bringers below (no texts).

LEEMANS, *Aeg. Mon.* iii, K.6f, pl. xiv; BOESER, *Beschreibung*, iv, Taf. viii.

(10) Stela.

LEEMANS, *Aeg. Mon.* iii, K.7, pl. xv; BOESER, *Beschreibung*, iv, Taf. ix; BRUNNER, *Ägyptische Kunst* in *Die Kunst dem Volke*, No. 85 (1937), Abb. 61; VAN DER LEEUW, *De Godsdienst van het oude Aegypte*, pl. 69 facing p. 128; VAN WIJNGAARDEN, *Meesterwerken*, pl. 54; *Gids* (1937), fig. on p. 112. Deceased and wife, from upper register, BREMMER, *Eg. kunst*, No. 20. Texts, PIEHL, *Inscr. hiéro.* 3 Sér. xxxvi–xxxvii [R].

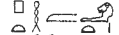
Staff of deceased, in Leyden Mus. Inv.AH.140C. LEEMANS, *Aeg. Mon.* ii, pl. lxxxv [88]; BOESER, *Beschreibung*, iv, fig. 6, p. 5; HASSAN (A.), *Stöcke und Stäbe im Pharaonischen Ägypten*, p. 153 [40] with Taf. vi [1]. See LEEMANS, *Descr. rais.* p. 103 [I.88]; BOESER, *Cat.* (1907), p. 174 [64].

PTAḤEMḤĒT  TY , Greatest of the directors of craftsmen, etc.
Temp. Tutankhamūn or Ay.

Father, Ḥori , God's father of Ptah.

Stela dedicated by son Say , Lector-priest in the Temple of Bubastis, in Brit. Mus. 972. MAYSTRE in *Ägypten und Kusch*, pp. 303–7 with fig.; WILKINSON MSS. ix. 140, and xviii. 72. See *Guide (Sculpture)*, p. 239 [876] (as Dyn. XXVI).

Stela, formerly in Amherst Colln. LIEDER squeezes, 12.1, 2. Text, MÁLEK in *Göttinger Miscellen*, No. 22 (1976), pp. 44 (from LIEDER), cf. 43–6. Names and titles, LIEBLEIN, *Dict.* No. 2070. See *Sotheby Sale Cat.* (AMHERST), June 13–17, 1921, No. 213.

Block,¹ registers, **I**, mourning scenes before kiosks with jars, **II**, funerary procession, 'Berliner Trauerrelief', in Berlin (East) Mus. 12411. ERMAN in *Ä.Z.* xxxiii (1895), Taf. i, ii [a], pp. 19–21; id. *Die Religion der Ägypter*, Taf. 8; WEIGALL, *Anc. Eg. . . . Art*, 227, 228 [upper]; *Aeg. und Vorderasiat. Alterthümer*, Taf. 110; STRÖMBOM, *Egyptens Konst.*, fig. 179; CAPART, *L'Art ég.* (1911), pls. 173–4; id. *L'Art ég.* i, pls. 148–9; BREASTED, *History*, fig. 132; FECHHEIMER, *Plastik* (1914), Taf. 155; (1923), Taf. 167; HAMANN, *Äg. Kunst*, Abb. 271–2; LÜDDECKENS in *Mitt. Kairo*, 11 (1943), Taf. 17, pp. 12, 117–19 [52–3], RANKE, *The Art of Ancient Egypt*, and BREASTED, *Geschichte Aegyptens* (1936), 230–1; WOLF, *Kunst*, Abb. 503–6, pp. 526–7; *Berlin. Ägypten und das Berliner Ägyptische Museum* (1955), Taf. 14; *Führer* (1961), Abb. 40, p. 65; HARI, *Horemheb*, pp. 61, 62–4 with pl. x [left] and fig. 12; SCHULMAN in *J.A.R.C.E.* iv (1965), pl. xxx, pp. 55–8; PRITCHARD, *Anc. Near East*, fig. 634; BRUNNER-TRAUT, *Die Alten Ägypter*, Taf. 58, VANDERSLEYEN, *Das Alte Ägypten*, Abb. 301–2. Right part, STEINDORFF, *Kunst*, 249. **I**, BORCHARDT in *Ä.Z.* 64 (1929), Taf. i [2], pp. 13–14; right end, VAN DE WALLE in *Bull. Mus. Roy.* 3 Sér. xii (1940), fig. 1, p. 76; middle

¹ Selected references.

part, PIRENNE, *Hist. civ.* ii, pls. 84-5 facing p. 380. Middle part of I and heads of three officials in II, PIJOÁN, *Summa Artis*, iii (1945), figs. 439-40. II, SPIEGELBERG in *Ä.Z.* 60 (1925), pp. 56-8 with fig.; Commander of the army and two Viziers, ALDRED, *Akhenaten*, pl. 78; heads of three officials, ANTHES, *Meisterwerke*, Taf. xxxviii; id. *Aeg. Plastik*, Taf. 48; WOLF, *Die Welt der Ägypter*, Taf. 84; MÜLLER, *Äg. Kunst*, Abb. 136. Details, SCHÄFER and ANDRAE, *Kunst* (1925), 373, 374 [1]; (1930 and 1942), 387, 388 [1]; LANGE, *Äg. Kunst*, pls. 104, 114; SCHÄFER, *Von äg. Kunst* (1919), Taf. 42; (1922 and 1930), Taf. 39; (1963), Taf. 29, 30; Eng. ed. *Principles of Egyptian Art*, pls. 48-50. Text, *Aeg. Inschr.* ii, pp. 179-80. See *Ausf. Verz.* pp. 151-2.

Pommel of stick, wood, in Leyden Mus. I.89. LEEMANS, *Aeg. Mon.* ii, pl. lxxxv [89]. See id. *Descr. rais.* p. 103 [I.89].

Top of model vase, pottery, in Louvre, E.8420. MAYSTRE in *Rev. d'Ég.* 27 (1975), pl. 14, pp. 175-6.

PTAḤMOSI $\square \text{X} \text{X} \text{X} \text{X}$, Greatest of the directors of craftsmen, etc. Temp. Amenophis III.

Parents, Dḥutmosi $\text{X} \text{X} \text{X}$, Governor of the town, Vizier, etc., and Tawi $\text{X} \text{X} \text{X}$.

Stela of deceased and brother Meryptah $\square \text{X} \text{X} \text{X} \text{X}$, Steward of the estate of Amenophis III, etc., with niche with figures of (a) mother, (b) Meryptah, (c) Ptaḥmosi, (d) father, (e) another Ptaḥmosi, Greatest of the directors of craftsmen, son of Menkheper $\text{X} \text{X} \text{X} \text{X}$, and double offering-scene and offering-text below, now in two parts, upper in Leyden Mus. Inv.AP.11, lower in London, Univ. Coll. 14463. BOSSE-GRIFFITHS in *J.E.A.* 41 (1955), pl. xiv, pp. 56-9, 62-3; texts, HELCK, *Urk.* iv. 1910-12 [705], cf. *Übersetz.* (1961), pp. 313-14; names and titles, LIEBLEIN, *Dict.* No. 608. Upper part, BOESER, *Beschreibung*, vi, Taf. xv; BOREUX in *Mon. Piot*, xxv (1921-2), fig. 3 (from BOESER), pp. 40-1; ANTHES in *Ä.Z.* 72 (1936), Abb. 1, pp. 65-6, cf. 61 [4a], 62 [5b]; name and titles on lintel, SCHIAPARELLI, *Mus. Arch. Firenze*, p. 205 [ii]; see LEEMANS, *Descr. rais.* p. 271 [V.14]; BOESER, *Cat.* (1907), p. 73 [124]. Lower part, STEWART, *Eg. Stelae*, i, pl. 16, pp. 26-7.

Stela of father, dedicated by deceased, in Florence Mus. 2565. MINTO, *Il Regio Museo Archeologico di Firenze*, fig. on p. 25 [lower right]; BOSSE-GRIFFITHS, op. cit. pl. xv [right], p. 60 [A]; BOSTICCO, *Le stele egiziane del Nuovo Regno*, fig. 33, pp. 39-41; ALINARI photo. 43837; SEYFFARTH MSS. iii. 3164. Text, SCHIAPARELLI, *Mus. Arch. Firenze*, pp. 292-5 [1570]; BEREND, *Principaux monuments*, p. 70; HELCK, *Urk.* iv. 1913-14 [706], cf. *Übersetz.* (1961), p. 315. Names and titles, LIEBLEIN, *Dict.* No. 651. See MIGLIARINI, *Indication*, p. 26.

Palette, steatite, in Berlin (East) Mus. 3427. ANTHES, op. cit. Taf. iii [4c], pp. 61, 64; SCHUBART, *Das Buch bei den Griechen und Römern* (1961), pl. on p. 25. Text, *Aeg. Inschr.* ii, p. 304; HELCK, *Urk.* iv. 1914 [707], cf. *Übersetz.* (1961), pp. 315-16; WILKINSON MSS. ii. 51D verso [left]. See *Ausf. Verz.* p. 218.

Probably this man (no indication of father) and from here.

Triangular stela, with 'Ankh-ptah $\square \text{X} \text{X} \text{X}$, Head of singers of the Temple of Ptah, etc., before deceased, and wife Maia $\text{X} \text{X} \text{X}$ and her sister on sides, in Florence Mus. 2537. BOSTICCO, *Le stele egiziane del Nuovo Regno*, figs. 34, 34a, b, pp. 41-2; SCHIAPARELLI, *Il significato simbolico delle Piramidi Egiziane in Reale Accademia dei Lincei, Atti, Classe di scienze morali* [etc.], *Memorie*, 3 Ser. xii (1884), pl. [3], pp. 126-7; CRAMER in *Ä.Z.* 72 (1936), Taf. vi [3], p. 91 note 3; MINTO, *Il Regio Museo Archeologico di Firenze*, fig. on p. 38 [upper

right]; BOSSE-GRIFFITHS in *J.E.A.* 41 (1955), fig. 1, p. 60 [D]; ALINARI photo. 43810. Text, BEREND, *Principaux monuments*, p. 49; HELCK, *Urk.* iv. 1919 [712], cf. *Übersetz.* (1961), p. 318; SCHIAPARELLI, *Mus. Arch. Firenze*, pp. 296-7 [1571]; of hymn to Rē, id. *Due iscrizioni inedite* [etc.] in *Giornale della Società asiatica italiana*, i (1887), p. 13 [c]. See MIGLIARINI, *Indication*, p. 13.

Pyramidion, granite, formerly in Passalacqua Colln., now in Berlin (East) Mus. 2276. ANTHES, op. cit. Taf. iii [4d], pp. 61, 64. East face, STEINDORFF, *Die Blütezeit des Pharaonenreichs* (1900), Abb. 71; ERMAN, *Die ägyptische Religion* (1905 and 1909), fig. 89; id. *Die Religion der Ägypter*, fig. 108; SCHÄFER und ANDRAE, *Kunst* (1925), 400 [upper]; (1930 and 1942), 416 [left]; RÜHLMANN, *Die Nadeln des Pharao*, Taf. 12; Szépművészeti Múzeum, Budapest. *Egyptomi művészet* [etc.] (1975), No. 97 with fig. 28. West face, SCHRADE, *Der verborgene Gott*, Taf. 43; Muzeul de artă, Bucharest. *Egiptul antic* [etc.] (1975), No. 38 with fig. on p. 17 [lower]; *Starożytna Kultura Egiptu i Mezopotamii* (Muzeum Narodowe w Warszawie, 1977), No. 6 with fig.; WILKINSON MSS. ii. 52B [lower]. Texts, *Aeg. Inscr.* ii, pp. 230-1; PIEHL in *P.S.B.A.* x (1888), p. 536 [10]. See PASSALACQUA, *Cat. raisonné*, p. 74 [1408]; *Ausf. Verz.* p. 158; *Führer* (1961), p. 61.

Statuette of deceased kneeling and grinding corn, with Chapter 6 of Book of the Dead, formerly in Lambruschini Colln. *Disegno d'una immagine egizia funeraria in un nuovo atteggiamento* (Rome, 1842) (fig. repr. GARDINER in *Ä.Z.* 43 (1906), fig. on p. 55).

Vessels, alabaster. (a) Copenhagen, Thorwaldsen Mus. 264; text, MADSEN in *Sphinx*, xiii (1910), p. 59 (as 267); see MÜLLER (L.), *Description des antiquités du Musée-Thorwaldsen* (1847), Section i, p. 25. (b) Fragment, Durham Univ. Gulbenkian Mus. N.1379; text, BIRCH, *Catalogue of the Collection of Egyptian Antiquities at Alnwick Castle*, p. 176. (c)-(f) Leyden Mus. H.299, 305, 309, 360; LEEMANS, *Aeg. Mon.* ii, pls. lx [299, 305], lxi [309], lxiii [360]; see id. *Descr. rais.* pp. 90-2 [H.299, 305, 309, 360]. (g) Brit. Mus. 4640 (formerly in Anastasi Colln.); HALL in *J.E.A.* xvii (1931), pl. vii [2], p. 48 [1]. (h) Lid, in Louvre, A.F. 6735; VANDIER D'ABBADIE, *Catalogue des objets de toilette égyptiens*, No. 588 with fig. (i) San José (California), Rosicrucian Museum, bought in Rome in 1901. (j) and (k) Zagreb Mus. 548, 567; MONNET SALEH, *Les antiquités égyptiennes de Zagreb*, pp. 123, 126 with figs. (l) Lid, formerly in Athanasi, Lee, and Amherst Collections; text [BONOMI], *Cat. . . . Hartwell House*, p. 69 [495]; see *Sotheby Sale Cat.* (AMHERST), June 13-17, 1921, No. 887 [2nd item].

Cubit-measure, in Leyden Mus. I.635. LEEMANS, *Aeg. Mon.* ii, pl. ccxlviii [635]; see id. *Descr. rais.* p. 135.

Alabaster rubber, in Leyden Mus. I.219. Id. *Aeg. Mon.* ii, pl. xciv [219]; see id. *Descr. rais.* p. 107.

Model knife, in Brit. Mus. 5472. HALL in *J.E.A.* xvii (1931), pl. vii [1, lower], p. 48 [4].

Pestle and mortar, breccia, formerly in St. Helier, Collection of the Société Jersiaise, now in Brit. Mus. 5683. Id. ib. pl. vii [1, upper], p. 48 [3]; WEIGALL in *P.S.B.A.* xxiii (1901), p. 12 with fig.

Vase-shaped model mace-head, alabaster, formerly in Nash Colln., now in Brit. Mus. 54989. NEWBERRY in *P.S.B.A.* xxi (1899), pl. ii, pp. 305-6 [3]; HALL, op. cit. pl. vii [4], p. 48 [2].

PTAḤMOSI , Chief steward of the Temple of Ramesses II in the domain of Ptah, etc. Temp. Ramesses II or later.

Wife, Nehyt , Songstress of the Mistress of the Sycamore.

Berlin (East) Museum.

Two jambs with texts of adoration of the sun and moon, Nos. 1631-2. No. 1632, *Gudar och människor vid Nilen* (Göteborg, 18 mars-20 maj 1973), No. 337 with pl. 28; Kunstmuseet i Ateneum Helsingfors. *Det eviga Egypten. Aegyptus aeterna* (1973), No. 308 with fig. 31; Sofia. *Izlozha Vechniyat Egipet* (1975), Vit. 8 [94] with fig. Texts of both, L. D. Text, i, p. 16 [top]; of No. 1631, *Aeg. Inschr.* ii, p. 217. See *Ausf. Verz.* p. 147.

Baltimore, Walters Art Gallery. Formerly in Castellane Colln.

Statue of wife seated, No.22.106. STEINDORFF, *Cat.* pls. xxi [106], cxii [106] (text), p. 40; id. in *The Journal of the Walters Art Gallery*, v (1942), figs. 1, 3, 5, pp. 11-13; x (1947), fig. 1, p. 58; HILL in *Archaeology*, 11 (1958), fig. on p. 277 [upper]; *35th Annual Report* (1967), fig. on p. 18.

Cairo Museum.

Lower part of seated statue of deceased and wife, basalt, found in Monastery of Apa Jeremias, JE 41532. QUIBELL, *Saqqara* (1908-10), pl. lxxxvi [1, 2], p. 146.

Blocks, deceased at table, JE 4873-5. Names and titles of JE 4874, MARIETTE, *Mon. div.* pl. 62 [d]; DE ROUGÉ, *Inscr. hiéro.* pl. xxx [bottom]; SCHIAPARELLI, *Mus. Arch. Firenze*, p. 330 [middle]; part, LIEBLEIN, *Dict.* No. 883. Monkey on JE 4875, VANDIER D'ABBADIE in *Rev. d'Ég.* 18 (1966), fig. 24, p. 165.

Florence Museum.

Block, registers, I (lower part only), offering-bringers before couple at table, II, children before deceased [and wife] at table, No. 2557. ROSELLINI, *Di un basso-rilievo egiziano* [etc.] (1826), passim with plate; BEREND, *Principaux monuments*, pl. viii, pp. 62-3; BOTTI in *Studi Rosellini*, i, Tav. ii [1], p. 14 with note 2; GALVANO, *L'Arte egiziana antica*, fig. 67; MINTO, *Il Regio Museo Archeologico di Firenze*, fig. on p. 35 [upper]; ALINARI photo. 31121. II, STEINDORFF, *Kunst*, 252; PETRIE ITAL. photos. 250-1. Texts, SCHIAPARELLI, *Mus. Arch. Firenze*, pp. 325-7 [1600]. Names and titles, LIEBLEIN, *Dict.* No. 772. See MIGLIARINI, *Indication*, pp. 22-3.

Leyden Museum. Formerly in Anastasi Collection.

Two statues, deceased seated. (a) Inv.AST.7; BOESER, *Beschreibung*, iv, Taf. xxxii; see LEEMANS, *Descr. rais.* p. 55 [D.65]. (b) Inv.AST.8; BOESER, op. cit. Taf. xxxi; LEEMANS, *Aeg. Mon.* ii, pl. v [33]; see id. *Descr. rais.* p. 51 [D.33].

Block, two registers, deceased and wife before divinities, including Rēc-Ḥarakhti and Ḥathor-cow, and with children, Inv.AP.54. Id. *Aeg. Mon.* iii, K.16, pls. xxv, xxvi; BOESER, op. cit. Taf. xxx. II, deceased before Rēc-Ḥarakhti, FORBES, *De textielindustrie van het oude Egypte* in *Rayon Revue*, vii [6] (1953), fig. on p. 270; children, BREMMER, *Eg. kunst*, Nos. 35-6; daughters, KLASSENS, *Egyptische kunst*, pl. 39. Names and titles, LIEBLEIN, *Dict.* No. 708 (except last, called V.92), *Suppl.* p. 966. See LEEMANS, *Descr. rais.* pp. 144-5 [K.16].

Four pillars, with texts, deceased adoring, and representations of *zad*-pillars, Inv.AP.51. Id. *Aeg. Mon.* iii, K.10-13, pls. xvii-xx; BOESER, *Beschreibung*, iv, Taf. xxvi-xxix. Deceased on K.13 and upper part on K.11, BREMMER, op. cit. Nos. 29, 28; deceased on K.13, KLASSENS, op. cit. pl. 38; DESROCHES NOBLECOURT, *Ancient Egypt* [etc.], pl. 25; *Artefact*, pl. 65, p. 38. Head of deceased on K.10, 11, 13, CAPART, *Documents*, i, pl. 62. See LEEMANS, *Descr. rais.* p. 142 [K.10-13]; GAUTHIER in *Ann. Serv.* xxxv (1935), pp. 85-7.

Others.

Statue of wife seated, formerly in Castellane Colln. and then in Pitcairn (Theodore) Colln. in Bryn Athyn (Penn.), now in a collection in Japan. STEINDORFF in *The Journal of the Walters Art Gallery*, v (1942), figs. 4, 6, pp. 11, 14; *Christie Sale Cat.* July 6, 1976, No. 117 with pl. 29; *The Connoisseur*, 192 [772] (June 1976), Advertisements, fig. on p. 96 [left]; *Apollo*, ciii [172] (June 1976), Advertisements, fig. on p. 108 [lower]; *ib.* civ (1976), fig. 6 on p. 423; DAVIS in *Country Life*, clx [4130] (Aug. 26, 1976), fig. 3, p. 527; DE RICCI MSS. D.62, 36-7.

Pyramidion, seen by Lepsius with Fernandez (dealer in Cairo). Name and titles, L. D. *Text*, i, p. 15 [bottom].

Papyrus-column, re-used in Monastery of Apa Jeremias (probably not in Cairo Mus. as stated in 1st ed. p. 193). Texts, QUIBELL, *Saqqara* (1907-8), p. 15.

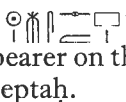
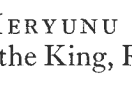
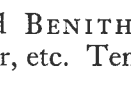
RA' MESES-EMPERRĒ  (also MERYUNU  and BENITHEN ) Fan-bearer on the right of the King, Royal butler, etc. Temp. Ramesses II to Merneptah.

Father, Yupa'a  Wife, Ēsi(?), Songstress of Amūn.

Monuments, BERLANDINI-GRENIER in *B.I.F.A.O.* 74 (1974), pp. 5-7 [i-vi].

Stela-fragment, in Vienne (Isère) Mus. 1555. VARILLE, *Les antiquités égyptiennes du Musée de Vienne (Isère)* (repr. from *Bulletin de la Société des Amis de Vienne*, 27-8 [1931-2]), pls. i [1], ii (drawing made when complete), pp. 2-7; BERLANDINI-GRENIER, *op. cit.* pl. ii, p. 5 [ii]. See COMARMOND, *Description des Antiquités . . . du Palais des Arts de Lyon* (1855-7), p. 650 [61] (cast).

Lintel-fragment(?), deceased kneeling before cow-headed Hathor, in Brooklyn Mus. 35.1315. BERLANDINI-GRENIER, *op. cit.* pl. iii, pp. 5-6 [iii]; VARILLE, *op. cit.* pl. i [2], pp. 7-9 [2] (cast). See COMARMOND, *op. cit.* p. 650 [60] (cast).

Pillar-fragment, deceased kneeling supporting *zad*-pillar, in Bologna, Museo Civico, 1913. HERMANN in *Ä.Z.* 75 (1939), Taf. viii [b], pp. 60-3; CURTO, *L'Egitto antico* (1961), Tav. 34 [57], pp. 85-6; BRESCIANI, *La collezione egizia nel Museo Civico di Bologna*, Tav. 35, p. 59; PETRIE ITAL. photo. 237. See KMINER-SZEDLO, *Catalogo di Antichità Egizie*, p. 188.

Blocks. Head of deceased with fan, with dealer in Cairo in 1972; BERLANDINI-GRENIER, *op. cit.* pl. i, fig. 1, pp. 1-4. Upper part of deceased and [wife holding] sistrum, in Rome, Villa Albani, 557; VARILLE, *op. cit.* pl. iv [5], p. 9 (as 566 in error); CURTO in *Oriens Antiquus*, vi (1967), fig. 10 [C], pp. 91-3 [14], cf. Tav. xxiv, xxv. Block, upper part of man (probably from here), in Rome, Villa Albani, 554; *id. ib.* fig. 10 [B], pp. 90-1 [13], cf. Tav. xxv.

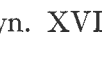
ROY  Head of bowmen, Overseer of horses, etc. Late Dyn. XVIII or early Dyn. XIX.

Wife, Maia , Songstress of Amūn, etc.

Berlin (East) Museum. Formerly in Passalacqua Collection.

Stela, No. 7290. *Ägyptisches Museum 1823-1973*, Abb. 38. II, SCHÄFER, *Von äg. Kunst* (1963), Taf. 27 [1]; Eng. ed. *Principles of Egyptian Art*, pl. 45; couple on right, (1919), Taf. 31 [2]; (1922 and 1930), Taf. 29 [2]. Text, *Aeg. Inschr.* ii, pp. 182-4. Names, LIEBLEIN, *Dict.* No. 1169. See *Ausf. Verz.* pp. 163-4; *Führer* (1961), p. 68.

Blocks, deceased and wife at table being censed, libated to, and purified, and receiving offerings, No. 7278. *Aeg. und Vorderasiat. Alterthümer*, Taf. 22; WEIGALL, *Anc. Eg. . . . Art*, 242; STEINDORFF, *Kunst*, 238; FECHHEIMER, *Plastik* (1914), Taf. 140; (1923), Taf. 150; SCHÄFER, *Von äg. Kunst* (1919), Taf. 33, 40 [3]; (1922 and 1930), Taf. 31, 37 [3]; (1963), Taf. 32, 42 [5]; Eng. ed. *Principles of Egyptian Art*, pls. 52, 72; id. *Äg. Kunst*, fig. on p. 18 [4]; ERMAN and RANKE, *Aegypten und aegyptisches Leben im Altertum* (1923), Taf. 17 [2]; PIJOÁN, *Summa Artis*, iii (1945), fig. 594; LANGE, *Lebensbilder*, pls. 19, 53; FRÜNDT in *Forschungen und Berichte*, 3/4 (1961), Abb. 1, p. 25; PANOFKY, *Tomb Sculpture*, fig. 11; MICHALOWSKI, *Art*, fig. 516; *Ausf. Verz.* Abb. 32, pp. 148–50; *Führer* (1961), Abb. 41, p. 66; SÉE, *Grandes villes*, fig. on p. 255. Deceased and wife, LANGE, *Pyramiden, Sphinxen, Pharaonen*, pl. 27. Two men censing, libating, and purifying, BYVANCK, *De Kunst*, pl. xlix [169]. Man purifying, ERMAN, *Die ägyptische Religion* (1905), fig. 60; (1909), fig. 66; id. *Die Religion der Ägypter*, fig. 82. Monkey, LANGE, *Ägyptische Tierplastik*, Abb. 20; id. in *Atlantis*, Jan. 1941, fig. on p. 28 [left lower]. Texts, *Aeg. Inscr.* ii, p. 181. Names, LIEBLEIN, *Dict.* No. 740. See PASSALACQUA, *Cat. raisonné*, pp. 72–3 [1405].

Block, man and wife with papyrus-branches before Rēc-Ḥarakhti, with six offering-bringers below, No. 7275. *Aeg. und Vorderasiat. Alterthümer*, Taf. 20; *Sculptures et textes*, fig. on p. 75; FRÜNDT, *op. cit.* Abb. 2, pp. 25–6; SCHARFF, *Götter Ägyptens*, Taf. 2; *Ägyptisches Museum 1823–1973*, Abb. 37; Szépművészeti Múzeum, Budapest. *Egyptomi művészet* [etc.] (1975), No. 46 with fig. 30. Man and wife before god, SCHARFF, *Aegyptische Sonnenlieder*, Taf. 1; man and wife, FECHHEIMER, *Plastik* (1914), Taf. 141; (1923), Taf. 151; SCHÄFER and ANDRAE, *Kunst* (1925), 355; (1930), 371; (1942), 369; DONADONI, *Arte Egizia*, fig. 117; head of man, SCHÄFER and SCHUBART in *Hauptwerke aus den Staatlichen Museen zu Berlin (Wilhelm von Bode zu ehren herausgegeben von den Abteilungsleitern)*, 1926), pl. 2 [right]. Texts, *Aeg. Inscr.* ii, p. 198. See PASSALACQUA, *op. cit.* pp. 55–6 [1378]; *Ausf. Verz.* p. 147; *Führer* (1961), p. 66.

Block, seven offering-bringers, No. 7277. FRÜNDT, *op. cit.* Abb. 3, p. 26. See PASSALACQUA, *op. cit.* p. 73 [1406]; *Ausf. Verz.* p. 147.

Brooklyn Museum. Formerly in N.Y. Hist. Soc. Colln.

Stela, lower part with fourteen lines of sun-hymns, No. 37.46E. Text, JAMES, *Corpus*, i, pl. lxxxvii [435], p. 178. See *N.Y.H.S. Cat.* p. 2 [14].

Block, five offering-bringers, No. 37.39E. FRÜNDT, *op. cit.* Abb. 4, p. 27. Text, JAMES, *Corpus*, i, pl. lxxxv [431], pp. 175–6. See *N.Y.H.S. Cat.* p. 13 [171].

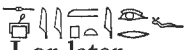
SAYEMPETREF , Head of goldworkers of the estate of Sethos I.
Temp. Sethos I or later.

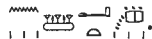
Wife, Neshet .

Cairo Museum.

Block, deceased and wife before tree-goddess, JE 52542. KEIMER in *Ann. Serv.* xxix (1929), pl. i, pp. 81–2, 86–8; WALLERT, *Die Palmen im Alten Ägypten*, Taf. xii, p. 136. Texts, KITCHEN, *Ram. Inscr.* i. 349 [145, 7].

Others.

Formerly in von Bissing Colln. and The Hague, Scheurleer Mus. In *Bibl.* v. 100 in error.

Stela, in The Hague, Gemeente Museum voor Oude Kunst, 1957. BLOK in *Bull. Antieke Beschaving*, i [2] (Dec. 1926), fig. 3, pp. 19-20 [v]; id. in *Acta Orientalia*, x (1932), Taf. v, pp. 87-90 [v]; SCHEURLEER in *Mededeelingen van den Dienst voor Kunsten en Wetenschappen der Gemeente's-Gravenhage*, v (1938), pp. 25-8 with fig.; id. in *Jaarbericht Ex Oriente Lux*, No. 7 (1940), pl. xvii, p. 551 [28]; Essen. 5000 Jahre, No. 210 with Abb. Texts, KITCHEN, *Ram. Inscr.* i. 348-9 [145, 5]. See Zürich. 5000 Jahre, pp. 70-1 [181] (as Amsterdam).

Block, deceased kneeling adoring, and remains of two people on right, now in Hanover Mus. 1935.200.187 (with another, see below). BLOK in *Bull. Antieke Beschaving*, i [2] (Dec. 1926), fig. 1, p. 17 [i]; id. in *Acta Orientalia*, x (1932), Taf. iii, pp. 81-2 [i]. Texts, KITCHEN, op. cit. 346 [145, 1].

Block, deceased kneeling adoring, in Jelgersma Colln. VAN WIJNGAARDEN in *Jaarbericht Ex Oriente Lux*, No. 6 (1939), pl. iv, p. 264; F.E.R.E. photo. 21459. Text, BLOK in *Acta Orientalia*, x (1932), pp. 82-3 [ii]; KITCHEN, op. cit. 346-7 [145, 2]. See BLOK in *Bull. Antieke Beschaving*, i [2] (Dec. 1926), p. 17 [ii]. See *Uit de Schatkamers der Oudheid. Jubileumtentoonstelling 1898-1938*. Stedelijk Museum, Amsterdam. 3 Sept.-16 Oct. 1938, pp. 70-1 [209b].

Block, three sons and three daughters as offering-bringers, in Hanover Mus. 1935.200.187 (with another, see above). Texts, BLOK in *Acta Orientalia*, x (1932), pp. 83-4 [iii]; KITCHEN, op. cit. 347 [145, 3]. See BLOK in *Bull. Antieke Beschaving*, i [2] (Dec. 1926), pp. 17-18 [iii].

Block, registers of scenes before deceased and wife, I, son Amenmosi censuring and libating, II, two sons and two daughters, in van Leer Colln. 8**. Id. ib. fig. 2, pp. 18-19 [iv]; id. in *Acta Orientalia*, x (1932), Taf. iv, pp. 84-6 [iv]; *Jaarbericht Ex Oriente Lux*, No. 5 (1937-8), pl. xxxi, pp. 467-8 with figs. 10, 11; *Uit de Schatkamers* [etc.], pl. 14, pp. 70-1 [209a]; JANSSEN in *Mededeelingen* [etc.], *Ex Oriente Lux*, No. 12 (1957), pl. v, pp. 17-19 [8**]; F.E.R.E. photo. 21458. Texts, KITCHEN, op. cit. 347-8 [145, 4].

Block, wife before Isis as Western goddess, in Hanover Mus. 4506. Texts, BLOK in *Acta Orientalia*, x (1932), p. 90; KITCHEN, op. cit. 349 [145, 6].

Block, four sons and three daughters as offering-bringers, in Hanover Mus. 1935.200.181.

SERBYKHEN (OR SERBYBYN)  IBY , Prophet of Amūn, Astarte, and Baal, etc. Probably Ramesside.

Berlin Museum. See *Ausf. Verz.* pp. 205, 209, 223.

Wooden lid of box of foreign work with animals in relief, No. 1882. PERROT and CHIPIEZ, *Histoire de l'Art dans l'Antiquité*, vi, *La Grèce Primitive*, fig. 409; *Burlington Fine Arts Club* (1895), pl. iv [33], p. 102 [12]; PETRIE, *The Relations of Egypt and Early Europe* in *Transactions of the Royal Society of Literature*, 2 Ser. xix (1897), fig. 9, pp. 76-7; NAVILLE in *Rev. Arch.* 3 Sér. xxxiii (1898), fig. 5, pp. 2, 4; DUSSAUD, *Les civilisations préhelléniques* [etc.] (1914), fig. 206, p. 289 (as fig. 205 in text); id. *L'art phénicien du II^e millénaire*, fig. 62, p. 100; BOSSERT, *Altkreta*, Abb. 350; id. *The Art of Ancient Crete*, fig. 560; FIMMEN, *Die kretisch-mykenische Kultur*, Abb. 164, pp. 166-7; SCHÄFER, *Die Religion und Kunst von El-Amarna*, Taf. 7; id. *Äg. Kunst*, fig. on p. 20 [2]. See *L. D. Text*, i, p. 17 [top]; MONTET, *Les reliques de l'art syrien dans l'Égypte du Nouvel Empire*, p. 161.

Gold ring of Amenophis IV, probably from here, No. 1785. Name, *L. D. Text*, i, p. 16 [near bottom].

Wooden staff of deceased, No. 1284. Text, id. ib. p. 16 [lower right]; *Aeg. Inscr.* ii, p. 306; HASSAN (A.), *Stöcke und Stäbe im Pharaonischen Ägypten*, pp. 139 [15], cf. 140.

WESI , Standard-bearer of the boat 'Front of the Beauty of Amûn', Head of bowmen of the Lord of the Two Lands, etc. Temp. Amenophis III.

Wife, Ipuy , Songstress of [Amûn].

Stela, in Munich, Staatl. Sammlung, ÄS 11. DYROFF and PÖRTNER, *Aegyptische Grabsteine und Denksteine aus süddeutschen Sammlungen*, ii, Taf. xv [23], pp. 32-3; *Äg. Sammlung* (1966), Abb. 47; *Staatl. Sammlung* (1972), pl. 34, p. 64; (1976), p. 88 with fig. on p. 87 (deceased and wife in upper register); NESTOR L'HÔTE MSS. 20414, 2nd carton, D (squeeze); SEYFFARTH MSS. iii, 2940-6 [right and top], 2940-6 verso [left]. Names and titles, LIEBLEIN, *Dict.* No. 870. See LAUTH, *Erklärendes Verzeichniss* [etc.] (1865), pp. 20-1 [III, 1, 7]; BOGOSLOVSKAYA in *Tutankhamon i ego vremya* (1976), pp. 59-61, cf. fig. on p. 60.

Two canopic-jars, alabaster, formerly in Nugent Colln. BLACKMAN in *J.E.A.* iv (1917), pl. xi [6, 7], pp. 42-3. Texts, WILKINSON MSS. xx. N.3 [middle left, and near bottom left].

(d) LATE AND PTOLEMAIC PERIODS

ʿANKHEFENSEKHMET , Prophet of Sekhmet of the Acacia-tree and of Ptaḥ. Dynasty XXVII.

Wife, Hathoremḥet .

Probably from here.

Blocks. Baltimore, Walters Art Gallery.

Two registers of musicians and games before deceased seated, with later graffito, Nos. 22.152-3 and another block (last formerly in Seattle, Art Mus. 11.6). HILL in *The Journal of the Walters Art Gallery*, xix-xx (1956-7), figs. 1, 2, 4, pp. 35-41, 97. Nos. 22.152-3, CAPART in *ib.* i (1938), figs. 1-3, pp. 13-17; STEINDORFF, *Cat.* pl. liv [274], pp. 80-1. Two pairs of players on left, PIRENNE, *Hist. civ.* iii, pl. 48 facing p. 189. *Senet*-players, D. K. H[ILL] in *The Bulletin of the Walters Art Gallery*, 3 [5] (Feb. 1951), fig. on 4th page; *id.* in *Archaeology*, 11 (1958), fig. on p. 278 [lower]. Block formerly in Seattle, *Handbook. Seattle Art Museum* (1951), fig. on p. 9 [lower]; F.E.R.E. photo. 13557.

Harpist before deceased and family, No. 22.38. STEINDORFF, *Cat.* pl. liv [275], p. 81; CAPART, *op. cit.* fig. 4; HICKMANN, *45 Siècles*, pl. lxxvi; SAINTE FARE GARNOT, *L'Égypte*, fig. on p. 98 [upper]; HILL in *The Journal of the Walters Art Gallery*, xix-xx (1956-7), fig. 3. Deceased and wife, *id.* in *Archaeology*, 11 (1958), fig. on p. 276 [lower]. Daughter and harpist, HICKMANN in *Cahiers d'Hist. Ég. Sér.* vi [5/6] (1954), fig. 17, p. 288.

ḤAREMAKHET , Greatest of the directors of craftsmen, Prophet of Ptolemy III Euergetes I, Ptolemy IV Philopator, and V Epiphanes, etc. Probably temp. Ptolemy V Epiphanes.



Parents, 'Anemḥo  and Ḥerʿankh .

See DE MEULENAERE in *Rivista degli Studi Orientali*, xxxiv (1959), p. 21.

Sarcophagus, in Leyden Mus. Inv.AMT.3. LEEMANS, *Aeg. Mon.* iii, L.9, pls. vii-xii; BOESER, *Beschreibung*, vii, Taf. ix, x. Names and titles, LIEBLEIN, *Dict.* No. 1316, *Suppl.* p. 982. See LEEMANS, *Descr. rais.* pp. 148-9 [L.9].

Stelae, hieroglyphic and demotic texts. (a) Brit. Mus. 391; SHARPE, *Eg. Inscr.* 1 Ser. 3; MUNRO, *Die spätägyptischen Totenstelen*, Taf. 62 [212], p. 340; SEYFFARTH MSS. xi. 9679; WILKINSON MSS. xvii. G 7 (with now lost demotic text); WILLIAMS rubbings iv. 77; see

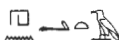
SHARPE, *Eg. Antiq.* pp. 125-6; *Guide (Sculpture)*, pp. 267-8 [1000]; QUAEGBEUR in *Chron. d'Ég.* xlix (1974), p. 69 [22]. (b) Vienna Mus. Inv. 125 (as No. 155 in 1st ed.); WRZINSKI, *Aegyptische Inschriften aus dem K.K. Hofmuseum in Wien*, Taf. ii [lower right], v [bottom], pp. 108-10 [i. 29]; SEYFFARTH MSS. xiv. 11327; texts, BRUGSCH, *Thes.* 915-16 [6]; LAUTH, *Die Schalltage* [etc.] in *Sitzungsberichte der königl. bayer. Akademie der Wissenschaften*, Philos.-philol. hist. Classe, iv [1] (1874), pl. at end [3], pp. 84-91; hieroglyphic text, VON BERGMANN in *Rec. Trav.* vii (1886), p. 193; names and titles, LIEBLEIN, *Dict.* No. 2508; some titles, BRUGSCH in *Ä.Z.* ii (1864), p. 18 [top]; demotic text, see SPIEGELBERG in *Rec. Trav.* xxx (1908), p. 150 [d]. See *Uebersicht* (1895), p. 38 [155]; (1923), p. 13 [155]; MUNRO, op. cit. p. 342 [W. 155]; QUAEGBEUR in *Chron. d'Ég.* xlix (1974), pp. 73-4 [35].

HENAT  KHNEBRĒ'-MEN¹ , Director of the estates of Neith, Chief lector-priest, etc. End of Dyn. XXVI.

Parents,¹ Uzahorresnet , Director of the estates, and Irterau . Possibly from here.

Blocks.

Deceased seated, with scribe and men bringing fowl before him, in Berlin (East) Mus. 15414. WRZ., *Atlas*, i. 391; ANTHES in *Ä.Z.* 75 (1939), Taf. i, ii [a], Abb. 1-4, pp. 21-31. Right part, SCHARFF in OTTO, *Handbuch der Archäologie*, i, Taf. 104 [1]; MÜLLER (H. W.) in *Encyclopedia of World Art*, iv, pl. 384 [top]; WOLF, *Kunst*, Abb. 684. 6th and 7th men, id. in *Archiv für Orientforschung*, vi (1930-1), Taf. xiii [2], pp. 268-9. Upper part of scribe and of 10th man, CAPART, *Documents*, ii, pl. 90. Upper part of 10th man, RAGAI, *L'Art*, pl. 19 [38]; PIRENNE, *Hist. civ.* iii, pl. 31 facing p. 140; MÜLLER, *Äg. Kunst*, Abb. 180.

Deceased seated, with offering-bringers before him, in Cairo Mus. Temp. No. 28.5.24.8. KUENTZ in *Mon. Piot*, xxxiii (1933), fig. 1, pp. 32-5; ANTHES, op. cit. Taf. ii [b], pp. 25-6 [ii]. See GAUTHIER in *Ann. Serv.* xxi (1921), p. 34 (texts).

Sarcophagus of deceased, in Brit. Mus. 86, see *Bibl.* iv. 72.

PSAMMETHEK , God's father, etc. Probably late Dyn. XXVI or early Dyn. XXVII.

Mother, Sebarkhyt .

In *Bibl.* i.² 674 but more likely from here, see YOYOTTE in *Bull. Soc. fr. d'Ég.* No. 60 (Feb. 1971), pp. 10-24.

Inscribed objects of deceased.

Wooden anthropoid coffin, in Grenoble Mus. 74. TRESSON, *Catalogue descriptif des antiquités égyptiennes de la Salle Saint-Ferriol* (repr. from *Bulletin de l'Académie delphinale*, 6 Sér. iv [1933]), pl. iii, pp. 47-9 [22]; KUÉNY in *Bull. Soc. fr. d'Ég.* No. 39 (April 1964), pl. i, p. 10; id. *L'Égypte ancienne au Musée de Grenoble*, figs. on 7th, 21st and 23rd pp. [22], cf. 20th and 21st pp. Text, MORET in *Revue Égyptologique*, n.s. i (1919), pp. 179-81 [xvi].

Two canopic-boxes, each with two Sons of Horus, in Louvre, N.2679-80 [E.2774-5]. Box N.2679, YOYOTTE, op. cit. fig. on p. 17, cf. pp. 17-18. See BOREUX, *Guide*, ii, p. 329; VANDIER, *Guide* (1948), p. 73 [3]; (1952), p. 75 [3]; (1973), p. 140.

¹ Not mentioned on the monuments cited here.



No. 16; *Antwerp. Cat. de la Collection d'antiquités égyptiennes* (1881), p. 43 [284]; *Oudheidkundige Musca. Vleeshuis, Cat. viii, Egypte*, p. 25 [3]; BOTHMER, *Eg. Sculp.* p. 119.

Berlin (West), Ägyptisches Museum.

Man seated, Dyn. I (Wolf) or early Dyn. II (Steindorff), No. 21839. STEINDORFF in *Ä.Z.* 56 (1918), Taf. vii, pp. 96–8; SCHARFF in *Berliner Museen*, xlviii (1927), Abb. 11, p. 60; id. *Die Altertümer der Vor- und Frühzeit Ägyptens*, ii, Taf. 20, pp. 65–7; id. *Grundzüge der ägyptischen Vorgeschichte in Morgenland*, 12 (1927), Taf. 14 [a], p. 63; SMITH, *Hist. Eg. Sculp.* pl. 2 [a], pp. 8–9; WOLF, *Kunst*, Abb. 31, pp. 59–60; STRÖMBOM, *Ägyptens Konst*, fig. 19; HORNEMANN, *Types*, iii, pl. 749; KAISER, *Äg. Mus. Berlin* (1967), Abb. 187, p. 20; BAKER, *Furniture*, fig. 22, p. 32.

Male wooden statue, 1st Int. Period, No. 22585. KAISER, *op. cit.* Abb. 303, p. 35; EVRARD-DERRIKS in *Cahiers de Mariemont*, 2 (1971), fig. 3, p. 7 with note 8.



Brooklyn Museum.

Nekht-sas , Overseer of Farâfra Oasis, Boundary official of a frontier-district, etc., late Dyn. V or Dyn. VI, two seated statues, Nos. 37.21–2E (formerly in Abbott and N.Y. Hist. Soc. Collns.), latter headless, with probably son Akhtihotp and probably wife Usertkau  on left side of seat, and probably son Sekhemka on right side. *Art of Ancient Egypt* (Emily Lowe Gallery, Hofstra University, Hempstead, New York, Feb. 22–April 6, 1971), No. 3 with figs.; texts, JAMES, *Corpus*, i, pl. xxii [47–8], p. 18, cf. pl. iv; see *N.Y.H.S. Cat.* pp. 8 [128], 13 [173]; titles, EDEL in *Ä.Z.* 81 (1956), pp. 67–8; FISCHER in *J.N.E.S.* 16 (1957), p. 226. No. 37.22E, COONEY in *Brooklyn Mus. Bull.* xiii [3] (Spring 1952), figs. 7–10, pp. 15–18; left side of seat, FAZZINI in *Miscellanea Wilbouriana*, 1 (1972), fig. 10, p. 42; right side, *Eg. Art . . . Brooklyn*, fig. 18.

Sekhemka , Inspector of scribes of the house of the master of the largesse, etc., seated, headless, diorite, set into limestone base, late Dyn. V, No. 37.23E (formerly in Abbott and N.Y. Hist. Soc. Collns.). JAMES in *J.E.A.* 49 (1963), pl. iii, pp. 9–12. Offerings on base, *Eg. Art . . . Brooklyn*, fig. 17; FAZZINI in *Miscellanea Wilbouriana*, 1 (1972), fig. 8, p. 42. Text, JAMES, *Corpus*, i, pl. xxii [51], pp. 19–20. See *N.Y.H.S. Cat.* p. 13 [169].

Ptahmosi , Governor of the town, Vizier, lower part of seated statue, temp. Amenophis III, No. 37.1512E (formerly in N.Y. Hist. Soc. Colln.). Text, JAMES, *Corpus*, i, pl. lxvii [256], p. 114. See *N.Y.H.S. Cat.* p. 13 [175].

Kneeling Negro captive with bound hands, bronze, probably originally from piece of furniture, 2nd half of Dyn. XVIII, No. 37.267E (formerly in Abbott and N.Y. Hist. Soc. Collns.). COONEY in *Brooklyn Mus. Bull.* x [3] (Spring 1949), fig. on p. 21; RIEFSTAHL, *People of the Black Land, Egypt*, Ser. i, No. 5, 2nd fig.; ALDRED, *N.K. Art* (1951), pl. 58; (1961), pl. 60; HORNEMANN, *Types*, iii, pl. 624; VANDIER, *Manuel*, iii, pl. clxiv [5], p. 653; WESTENDORF, *Das Alte Ägypten*, fig. on p. 135. Head, MYŚLIWIEC in *Ä.Z.* 98 (1972), fig. 11 on p. 89. See *N.Y.H.S. Cat.* p. 50 [792].

Siēsi , Royal scribe, son of 'Aḥmosi , war-priest of Osiris, grinding corn, bronze, temp. Tuthmosis IV to Amenophis III, No. 37.125E (formerly in Abbott and N.Y. Hist. Soc. Collns.). CAPART in *Chron. d'Ég.* xviii (1943), fig. 17, pp. 32–4; BREASTED (Jr.), *Eg. Servant Statues*, pl. 23, p. 24 [8]; HORNEMANN, *Types*, iii, pl. 581. Text, JAMES, *Corpus*, i, pl. lxx [271], p. 120. See BONOMI, *Cat. Colln. Abbott*, p. 24 [227]; *N.Y.H.S. Cat.* (1915), p. 55 [893]; RANSOM in *The New-York Historical Society Quarterly Bulletin*, i [4] (Jan. 1918), p. 97.

A son of Osorkon II and Keramama, probably Sheshonk, block-stature with figure of Osiris at front and figure of mother and divinities in relief, No. 37.595E (formerly in Abbott and N.Y. Hist. Soc. Collns.). JACQUET-GORDON in *The Brooklyn Museum Annual*, vi (1964-5), figs. 1-5, pp. 43-9. Sketch and cartouches, WILKINSON MSS. xx.A.4C [lower left]. See *N.Y.H.S. Cat.* p. 4 [48].

Brussels, Mus. Roy. d'Art et d'Hist.



Head, Dyn. V, E.7215. BILLE-DE MOT in *Bull. Mus. Roy.* 3 Sér. xi (1939), fig. 19, pp. 21-2; *Bruxelles. Mus. Roy. d'Art et d'Histoire* (1958). *Antiquités, Extrême-Orient, Ethnographie*, No. 4 with pl.; PIRENNE, *Hist. civ.* i, pl. vii facing p. 240.

Cairo Museum.

Old Kingdom.

‘Aḥauka , Inspector of hairdressers of the Great House, statue-base, Dyn. V, CG 304. Text, BORCHARDT, *Statuen*, i, p. 182.

Ak  and woman Hētephēnefert  seated, double-stature, Dyn. V, JE 35204. HORNEMANN, *Types*, v, pl. 1189 (as Giza). See MASPERO, *Guide*, p. 70 [153] (as Giza).

‘Ankhirptaḥ  Secretary of the Toilet-house, etc., seated, and wife Irt-nub  (almost completely lost), double-stature, with sons and butchers on sides and back of seat, Dyn. V, CG 376. BORCHARDT, *Statuen*, i, Bl. 59, pp. 197-8 with fig. Name and titles of deceased and dedication of wife, SETHE, *Urk.* i. 73 [50].

‘Athma(?)  Prophet of Rē^c in the Sun-temple of Saḥurē, etc., temp. Saḥurē or later, CG 99. BORCHARDT, op. cit. Bl. 22, pp. 77-8.

Hēpi  Royal acquaintance, statue-base, Dyn. V, CG 309. Text, id. ib. p. 183.

Hesy  Overseer of *sr*-officials, etc., scribe-stature, Dyn. V, CG 104. Text, id. ib. p. 82.

Imḥōtep  Judge and Supervisor of police, Inspector of *warb*-priests, wood, Dyn. V, CG 270. Id. ib. Bl. 58, pp. 171-2.

Iris  Greatest of the Ten of Upper Egypt, Prophet of Ma'et, etc., seated, grey hard stone, Dyn. V, CG 131. Id. ib. Bl. 29, pp. 98-9.

Itep  Lector-priest, Dyn. V, CG 7. Id. ib. Bl. 2, pp. 7-8; incomplete, PETRIE Giza photo. 536.

Kaḥif  Prophet of the Pyramid of Neuserre, etc., wood, temp. Neuserre or later, CG 268. BORCHARDT, op. cit. Bl. 57, pp. 170-1.

Khnemḥotp  (dwarf), Overseer of linen (*sšrw*), *ka*-servant, late Dyn. V or Dyn. VI, CG 144. Id. ib. Bl. 32, pp. 105-6; MASPERO, *Le nain Khnoumhotpou* in RAYET, *Monuments de l'art antique*, i, Livraison III, pl. xiv; id. *Essais*, fig. 14, pp. 83-9; id. *Eg. Art*, pl. facing p. 86, cf. pp. 85-9; id. *L'Arch. ég.* (1887), fig. 188; (1907), fig. 200; id. *Égypte*, fig. 150; id. *Hist. anc.* i, fig. on p. 280; id. *Guide* (1914), fig. 7, p. 63 [159]; (1915), fig. 10, p. 72 [160]; PERROT and CHIPIEZ, *Hist. de l'Art*, i, figs. 453-4; CAPART, *Memphis*, fig. 341; id. *L'Art ég.* ii, pl. 264; RUFFER, *On dwarfs and other deformed persons* in *Bulletin de la Société Archéologique d'Alexandrie*, 13 (1910), pl. i, pp. 165-7; DAWSON, *Magician and Leech*, pl. iv [b] facing p. 106; ROSS, *The Art of Egypt*, pl. on p. 109 [3]; SCHÄFER, *Äg. Kunst*, fig. on p. 25 [1]; id. and ANDRAE, *Kunst* (1925), 231 [upper left]; (1930), 241 [upper left]; CAROTTI, *L'Arte*, fig. 49; ERMAN and RANKE, *Aegypten und aegyptisches Leben im Altertum* (1923), Taf. 10 [3]; SPIEGELBERG, *Geschichte*, Abb. 29; ENGELBACH in *Ann. Serv.* xxxviii (1938), pl. xxxvi, p. 285; id. *Introduction*, pl. x [2]; PIJOÁN, *Summa Artis*, iii (1945), fig. 166; ALDRED, *O.K. Art*, pl. 52; WOLF, *Kunst*, Abb. 135; RIAD, *La Médecine au temps des Pharaons*, figs. 12, 13;

BAKRY in *Egypt Trav. Mag.* No. 42 (Feb. 1958), fig. on p. 13 [upper]; *The Egyptian Education Bureau London. The Bulletin*, No. 35 (May–June 1949), 3rd pl. after p. 8 [upper right]; MITRY, *Illus. Cat.* No. 160; RICHTER in *The Journal of Roman Studies*, xlv (1955), pl. i [4], p. 41 with note 18; HORNEMANN, *Types*, i, pl. 10; *Great Museums*, pl. 24; DONADONI, *Egyptian Museum Cairo*, pl. on p. 51 [lower]; VANDERSLEYEN, *Das Alte Ägypten*, Abb. 142 [b]. Hieroglyph ρ , FISCHER, *Varia*, fig. 16 [d], p. 110.

Mereri $\text{𓂏} \text{𓂏}$, Noblewoman of the King, Prophetess of Hathor, etc., seated, headless, Dyn. VI, CG 369. Text, BORCHARDT, *Statuen*, i, p. 194.

Neferhōtep $\text{𓂏} \text{𓂏}$, Judge and Scribe, Overseer of the jury, etc., seated, Dyn. V, CG 206. Id. ib. Bl. 43, p. 139.

Neferiru $\text{𓂏} \text{𓂏}$ seated and probably wife Sitmert $\text{𓂏} \text{𓂏}$, two fragments of base of double-statue, Dyn. V, CG 314. See id. ib. pp. 184–5 (text).

Nesekha $\text{𓂏} \text{𓂏}$, Elder of the Hall, King's *wab*-priest, nude statue, Dyn. V, CG 23. Id. ib. Bl. 6, p. 25; WEIGALL, *Anc. Eg. . . . Art*, 33; VON BISSING, *Denkmäler*, i, Taf. 12 [a]; RIAD, *La Médecine au temps des Pharaons*, fig. 52. Upper part and detail showing circumcision, PETRIE GIZA photos. 525–6; detail, DE WIT in *Ä.Z.* 99 (1972–3), fig. 3, p. 46. See MASPERO, *Guide*, p. 72 [162].

Nīankhrēc $\text{𓂏} \text{𓂏}$, Secretary of the estates of Neith, Boundary official of (the district) 'Star of Horus Foremost of Heaven', etc., seated, with wife Irt-nub $\text{𓂏} \text{𓂏}$, and sons Ra'shepses $\text{𓂏} \text{𓂏}$ and Nīankhrēc-nezes, both Prophets of Rēc and Hathor in the Sun-temples of Userkaf and Neferirkarēc, etc., statue-group, temp. Neferirkarēc or later, CG 55. (Publications show the group variously complete.) BORCHARDT, *Statuen*, i, Bl. 14, pp. 48–9; MARIETTE, *Voyage*, i, on pl. 8, p. 38; VON BISSING, *Denkmäler*, Text to Taf. 4, 68A [2nd fig.]; id. *Äg. Kunstgeschichte*, Taf. lxii [382], Text, i, p. 87; CAPART, *L'Art ég.* (1911), pl. 117; id. *L'Art ég.* ii, pl. 262; id. *Memphis*, fig. 342; SCHARFF in OTTO, *Handbuch der Archäologie*, i, Taf. 73 [3], p. 518; SCHÄFER and ANDRAE, *Kunst* (1930 and 1942), 242 [right]; FETT, *Mumier og sfinks*, pl. on p. 105; COTT in *Worcester Art Museum Annual*, i (1935–6), fig. 2, p. 17; MEIER-GRAEFE, *Pyramide und Tempel*, Taf. 13; SHOUKRY, *Privatgrabstatue*, Abb. 30, p. 151 [7]; WOLF, *Kunst*, Abb. 130, p. 164; HORNEMANN, *Types*, vi, pls. 1460–1.

Nika'ankh $\text{𓂏} \text{𓂏}$, Director of the Palace, Secretary of the Toilet-house, etc., fragments, granite, Dyn. V, CG 136. See BORCHARDT, *Statuen*, i, pp. 101–2.

Nimesuptah $\text{𓂏} \text{𓂏}$, Scribe, seated, Dyn. VI, CG 191. Id. ib. Bl. 41, pp. 130–1.

Nüfer $\text{𓂏} \text{𓂏}$, Director of brewers, Dyn. V, CG 145. Id. ib. Bl. 32, pp. 106–7; MARIETTE, *Album du Musée de Boulaq* (1872), on pl. 25; MASPERO, *Hist. anc.* i, fig. on p. 411; id. *Guide* (1914), fig. 15, p. 160 [150]; (1915), fig. 21, p. 69 [151]; id. *Égypte*, fig. 158; PERROT and CHIPIEZ, *Hist. de l'Art*, i, fig. 426; VON BISSING, *Denkmäler*, i, Taf. 11A [b, c]; CAPART, *L'Art ég.* (1909), pl. 17; id. *L'Art ég.* ii, pl. 240; id. *Memphis*, fig. 333; WEIGALL, *Anc. Eg. . . . Art*, 31; SCHARFF in *J.E.A.* 26 (1940), pl. ix [1], p. 47; ALDRED, *O.K. Art*, pl. 46; GILBERT in *Chron. d'Ég.* xxix (1954), fig. 18, p. 202; London. *5000 Years*, pl. x, p. 14 [21]; Vienna. *5000 Jahre*, No. 24 with Abb.; Brussels. *5000 ans*, fig. 8, p. 22 [12]; Essen. *5000 Jahre*, No. 26 with Abb.; Louisiana. *5000 ans*, No. 57 with fig.; MICHALOWSKI, *Art*, fig. 210.

Sankhuptah $\text{𓂏} \text{𓂏}$, Overlord of Nekheb, Director of the Two Seats, Secretary of the Toilet-house, etc., Dyn. V. (a) With wife Nubibnebti $\text{𓂏} \text{𓂏}$, King's daughter of his body, etc., kneeling by his right leg, heads lost, CG 37. (b) Seated, headless, with wife kneeling by his right leg, CG 196. (c) Seated, headless, with sons by his legs, CG 201. All, BORCHARDT, *Statuen*, i, Bl. 10, 41–2, pp. 35–6, 133–4, 136. CG 37, HORNEMANN, *Types*, v, pl. 1174. Some texts of CG 37 and 196, DE ROUGÉ, *Inscr. hiéro.* pls. ccci [4], v [bottom].

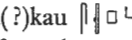
Seḳed(?)kau , Inspector of scribes of the sealed documents, Dyn. V. (a) Seated, with wife and son, statue-group, CG 101; BORCHARDT, op. cit. Bl. 23, pp. 79-80; VON BISSING, *Äg. Kunstgeschichte*, Taf. lxiii [386], *Text*, ii, p. 86 note 18; id. *Einführung in die Geschichte der Ägyptischen Kunst* [etc.], Taf. iii [2]; MASPERO, *Égypte*, fig. 29; HORNE-MANN, *Types*, v, pl. 1376; name, RANKE, *Die ägyptischen Personennamen*, i, p. 321 [2]; see MASPERO, *Guide*, p. 73 [166]. (b) Seated, CG 208; text, BORCHARDT, op. cit. p. 140.

Sethef , Scribe, seated, Dyn. V, CG 204. Id. ib. Bl. 43, p. 138.

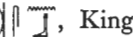
Snefrusonb  , King's *warb*-priest, etc., seated, Dyn. V, from here or Dahshûr, CG 137. Id. ib. Bl. 31, p. 102.

Sonb, fragmentary, Old Kingdom, JE 8388.

A Prophet, etc., name lost, seated, Dyn. V, CG 49. Id. ib. Bl. 13, pp. 44-5.

Two double-statues, two men seated, and standing (latter partly restored), granite, Dyn. V, CG 165, 168. Id. ib. Bl. 37, pp. 118, 119; BOREUX in *Mélanges Maspero*, i [2], pls. ii [3], i [4], pp. 811, 810; HORNE-MANN, *Types*, iv, pls. 1116, 1088.

Scribe-statues, granite, Dyn. V. (a) CG 57; BORCHARDT, op. cit. Bl. 15, p. 51; VON BISSING, *Denkmäler*, i, Taf. 8; RANKE, *The Art of Ancient Egypt*, and BREASTED, *Geschichte Aegyptens* (1936), 65; STRÖMBOM, *Egyptens Konst*, fig. 54 [a]; HAMANN, *Äg. Kunst*, Abb. 7; ANTHES, *Äg. Plastik*, Taf. 13; id. *Meisterwerke*, Taf. xiii; BYVANCK, *De Kunst*, pl. xvii [65]; WOLF, *Kunst*, Abb. 126, p. 161; FORMAN (W. and B.) and VILÍMKOVÁ, *Äg. Art*, pl. 22; HORNE-MANN, *Types*, ii, pl. 407; MÜLLER, *Äg. Kunst*, Abb. 38; GROENEWEGEN-FRANKFORT and ASHMOLE, *Art of the Ancient World*, fig. 33; see MASPERO, *Guide*, p. 50 [96]. (b) CG 59; BORCHARDT, op. cit. Bl. 15, p. 52; HORNE-MANN, op. cit. ii, pl. 403; see MASPERO, op. cit. p. 73 [165]. (c) CG 160; BORCHARDT, op. cit. Bl. 35, p. 115; VON BISSING, *Äg. Kunstgeschichte*, Taf. lxxv [400]; HORNE-MANN, op. cit. ii, pl. 420. (d) JE 65907; id. ib. ii, pl. 406.

Scribe-statues, Dyn. V. (a) With remains of text on papyrus, CG 78; BORCHARDT, *Statuen*, i, Bl. 18, pp. 63-4; MARIETTE, *Album du Musée de Boulaq* (1872), on pl. 2; Vienna. *5000 Jahre*, No. 26 with Abb.; Brussels. *5000 ans*, fig. 14, p. 22 [13]; Essen. *5000 Jahre*, No. 30 with Abb.; London. *5000 Years*, pl. vi, p. 14 [24]; Stockholm. *5000 år*, No. 27 with fig.; Louisiana. *5000 års*, No. 61 with fig.; Zürich. *5000 Jahre*, Abb. 35, p. 58 [114]; Amsterdam. *5000 jaar*, fig. 5 [20]; HORNE-MANN, *Types*, ii, pl. 422; WESTENDORF, *Das Alte Ägypten*, fig. on p. 54 [lower]; PERC, *Spomeniki starega Egipta* (1974), No. 10 with fig.; upper part, SAMEH, *Daily Life*, fig. on p. 152 [lower left]. (b) Two fragments, CG 371; see BORCHARDT, op. cit. p. 195.

Seated statues, Dyn. V. (a)-(c) Three, granite, CG 161, 166, 169; id. ib. Bl. 36, 37, 38, pp. 115-16, 118, 119-20. (d) CG 8; id. ib. Bl. 2, p. 8; upper part, PETRIE GÍZA photos. 523-4. (e) CG 84; see BORCHARDT, op. cit. pp. 67-8. (f) CG 92; id. ib. Bl. 21, pp. 72-3.

Male statue, alabaster, Dyn. V, CG 132. Id. ib. Bl. 30, p. 99.

Female statue, alabaster, Dyn. V, CG 134. Id. ib. Bl. 30, pp. 100-1; Brussels. *5000 ans*, fig. 9, p. 23 [16]; Vienna. *5000 Jahre*, No. 23 with Abb.; Zürich. *5000 Jahre*, Abb. 28, p. 58 [113]; Amsterdam. *5000 jaar*, fig. 9 [27]; Louisiana. *5000 års*, No. 58 with fig.; PERC, *Spomeniki starega Egipta* (1974), No. 8 with fig.

Male statue, Dyn. V, CG 98. See BORCHARDT, *Statuen*, i, p. 77.

Male wooden statues, Dyn. V. (a) CG 155; id. ib. Bl. 35, pp. 112-13; DRIOTON and SVED, *Art ég.* fig. 26. (b) Upper part, possibly from tomb No. 36 [C 8] (Capart), CG 32; BORCHARDT, op. cit. Bl. 8, p. 31; WEIGALL, *Anc. Eg. . . . Art*, 52; MASPERO, *L'Arch. ég.* (1907), fig. 197; id. *Égypte*, fig. 156; CAPART in *J.E.A.* vi (1920), pls. xxvii [3], xxviii, pp. 232, 233; id. *L'Art ég.* (1909), pl. 16; id. *L'Art ég.* ii, pl. 252; id. *Documents*, i, pls. 7, 8;

FECHHEIMER, *Plastik*, Taf. 39, 40; MURRAY, *Sculpture*, pl. xii [3]; *Encycl. phot. Caire*, pls. 30-1; PIRENNE, *Hist. civ.* i, pl. 49 facing p. 156; DONADONI, *Egyptian Museum Cairo*, pl. on p. 39 [left]; MICHALOWSKI, *Art*, fig. 227; head, PAVLOV, *Skul'pturnyi portret v drevnem Egipte*, pl. facing p. 20; LANGE, *Äg. Kunst*, pl. 28; id. *Ägyptische Bildnisse*, Taf. 8; DE RACHEWILTZ, *L'Arte*, Tav. 40; DE WIT, *Oud-Egyptische Kunst*, fig. 21 facing p. 48; VANDERSLEYEN, *Das Alte Ägypten*, Abb. 137 [b]; see MASPERO, *Guide*, p. 55 [116].

Heads, Dyn. V. (a) CG 264; BORCHARDT, *Statuen*, i, Bl. 57, p. 168. (b) CG 292; see id. ib. p. 179.

Female wooden statues, Dyn. V. (a) CG 121; id. ib. Bl. 27, pp. 92-3. (b) CG 269; see id. ib. p. 171.

Upper part of male statue, granite, Dyn. V, CG 167. Id. ib. Bl. 37, pp. 118-19; PETRIE Giza photo. 539.

Male brewer, Dyn. V, CG 117. BORCHARDT, op. cit. Bl. 26, p. 90; id. *Works of Art*, pl. 5; MARIETTE, *Album du Musée de Boulaq* (1872), on pl. 20; PERROT and CHIPIEZ, *Hist. de l'Art*, i, fig. 447; MASPERO, *L'Arch. ég.* (1887), fig. 187; (1907), fig. 199; id. *Égypte*, fig. 123; id. and ROEDER, *Führer*, Taf. 8; SPIEGELBERG, *Geschichte*, Abb. 30; SPRINGER, *Die Kunst des Altertums* (1923), Abb. 61; *Encycl. phot. Caire*, pl. 37; HORNEMANN, *Types*, ii, pl. 360; ALDRED, *O.K. Art*, pl. 55; VANDIER, *Eg. Sculpture*, pl. 36; WOLF, *Die Kultur Ägyptens*, Abb. 6; MICHALOWSKI, *Art*, fig. 226; id. *Piramidy i mastaby*, pl. 67; WESTENDORF, *Das Alte Ägypten*, fig. on p. 54 [upper]; *Great Museums*, fig. on p. 229 [3]; DONADONI, *Egyptian Museum Cairo*, pl. on p. 49 [right]; DAVID, *The Egyptian Kingdoms*, fig. on p. 129; VANDERSLEYEN, *Das Alte Ägypten*, Abb. 357 [a]. See BREASTED (Jr.), *Eg. Servant Statues*, p. 30 [3].

Woman sifting flour, Dyn. IV-V, JE 35313. See id. ib. p. 25 [2]; SMITH, *Hist. Eg. Sculp.* p. 98 [e, 2].

Kneeling man performing unidentified task, head now lost, Dyn. V, CG 329. BORCHARDT, *Statuen*, i, Bl. 58, pp. 188-9; MARIETTE, *Album du Musée de Boulaq* (1872), on pl. 20 (with head); HORNEMANN, *Types*, iii, pl. 642. See BREASTED (Jr.), *Eg. Servant Statues*, p. 104 [2].

Female offering-bringer with basket, wood, late Old Kingdom, CG 1251. See BORCHARDT, *Statuen*, iv, pp. 129-30.



Middle Kingdom.

Mentuhotp , Overseer of fields, etc., seated, fragmentary, CG 526. See id. ib. ii, pp. 81-2.

Man in long pleated garment, headless, sandstone, temp. Sesostri III to Amenemhēt III, Temp. No. 10.4.22.5. EVERS, *Staat aus dem Stein*, i, Taf. 97 [A].

Female head with wavy hair, wood, CG 812. BORCHARDT, op. cit. iii, Bl. 150, p. 107; PETRIE Giza photo. 556; DAVIES MSS. photo. 1.857. See MASPERO, *Guide*, p. 450 [4249].

New Kingdom.

Paser , Scribe of the Vizier Ptaḥmosi, Director of works in the Temple of Nut(?), son of Rēc , Mayor of Ma'ti, etc., scribe-statue, sandstone, temp. Amenophis III, CG 827. BORCHARDT, *Statuen*, iii, Bl. 153, p. 115; HORNEMANN, *Types*, ii, pl. 390.

Sitmut , (woman), wooden statuette, temp. Amenophis III, CG 452. BORCHARDT, op. cit. ii, Bl. 75, p. 48 with fig. See id. in *A.Z.* xxxv (1897), pp. 167-8.

Female wooden statue, probably temp. Amenophis III, found with last, CG 803. Id.

Statuen, iii, Bl. 148, p. 101; CAPART, *L'Art ég.* ii, pl. 333. Upper part, FORMAN (W. and B.) and VILÍMKOVÁ, *Eg. Art*, pl. 81; COTTRELL, *Egypt*, fig. 71.

Thay and wife Nia seated, double-statue, late Dyn. XVIII or early Dyn. XIX, CG 628. BORCHARDT, *Statuen*, ii, Bl. 115, pp. 175-6; MASPERO, *Guide*, fig. 66, pp. 194-5 [767]; id. *Le Musée Égyptien*, ii, pl. vi, pp. 16-19; id. *Égypte*, fig. 345; id. and ROEDER, *Führer*, Taf. 29 [a], p. 54 [556]; CAPART, *L'Art ég.* (1909), pl. 69; id. *L'Art ég.* ii, pl. 372; RICHER, *Le Nu*, fig. 109; *Encycl. phot. Caire*, pls. 146-7; DONADONI, *Egyptian Museum Cairo*, pl. on p. 132; HORNEMANN, *Types*, v, pl. 1205; DE RACHEWILTZ, *L'Arte*, Tav. 50, p. 60; PETRIE GÍZA photos. 589-91 (No. 590 = PETRIE, *History*, ii, fig. 93). Upper parts or heads, FORMAN (W. and B.) and VILÍMKOVÁ, *Eg. Art*, pls. 98-9; DAUMAS, *Civ. de l'Ég.* pl. 194; LANGE (K.), *Ägyptische Bildnisse*, Taf. 26-7; of Thay, CAPART in *Mon. Piot*, xiii (1906), fig. 1, p. 34; MÜLLER (H. W.) in *Münchner Jahrb.* 3 Ser. xviii (1967), Abb. 16, pp. 13, 27; of Nia, HARRIS, *Egyptian Art*, pl. 43; WOLF, *Kunst*, Abb. 550. Names and titles, LIEBLEIN, *Dict.* No. 978.

Wooden statuettes of men in pleated garments, late Dyn. XVIII or Dyn. XIX. (a) CG 798; BORCHARDT, *Statuen*, iii, Bl. 147, p. 98; id. *Works of Art*, pl. 10 [left]; VON BISSING, *Denkmäler*, i, Taf. 50 [b]; WEIGALL, *Anc. Eg. . . . Art*, 244; MASPERO and ROEDER, *Führer*, Taf. 57 [left]; STEINDORFF, *Die Blütezeit des Pharaonenreichs* (1926), Abb. 120 [left and right]; RANKE, *The Art of Ancient Egypt*, and BREASTED, *Geschichte Aegyptens* (1936), 142-3; POULSEN (F.), *Ägyptens Kunst* (1933), fig. 69; LUGN, *Kunst*, fig. 71 [left]. (b) CG 799; BORCHARDT, *Statuen*, iii, Bl. 147, pp. 98-9. (c) Khent-siennebta(?) CG 805; id. ib. Bl. 149, p. 102. (d) Hori Rēc , First prophet of Wert-ḥekau, Chamberlain, CG 806; id. ib. Bl. 149, pp. 102-3 with fig.; id. *Works of Art*, pl. 10 [right]; WEIGALL, *Anc. Eg. . . . Art*, 241 [3]; LUGN, *Kunst*, fig. 71 [right]; MASPERO and ROEDER, *Führer*, Taf. 57 [right], p. 106; *Encycl. phot. Caire*, pl. 148; *Great Museums*, fig. on p. 228 [16]; DONADONI, *Egyptian Museum Cairo*, pl. on p. 136.

Female wooden statuettes, late Dyn. XVIII or Dyn. XIX. (a) Ḥenutwezebt (?), CG 801; BORCHARDT, *Statuen*, iii, Bl. 148, pp. 99-100. (b) Ḥenutnakhtu CG 804; id. ib. Bl. 148, pp. 101-2; id. *Works of Art*, pl. 10 [middle]; VON BISSING, *Denkmäler*, i, Taf. 50 [a]; WEIGALL, *Anc. Eg. . . . Art*, 225; MASPERO and ROEDER, *Führer*, Taf. 57 [middle], p. 106; STEINDORFF, *Die Blütezeit des Pharaonenreichs* (1926), Abb. 120 [middle], p. 176; LUGN, *Kunst*, fig. 71 [middle]; HEUZEY (L. and J.), *Histoire du costume* [etc.], *L'Orient*, pl. xxi [1, 3]; RANKE, *The Art of Ancient Egypt*, and BREASTED, *Geschichte Aegyptens* (1936), 156-7; POULSEN (F.), *Ägyptens Kunst* (1933), fig. 70; MURRAY, *Splendour*, pl. 1 [4]; BUSCHOR, *Bildnisstufen*, Abb. 109, p. 266; FORMAN (W. and B.) and VILÍMKOVÁ, *Eg. Art*, pl. 82.

Squatting woman nursing child, three statuettes, Dyn. XVIII, CG 1252-4. BORCHARDT, *Statuen*, iv, Bl. 173, pp. 130-1.

Khačy Overseer of the Treasury of the Temple of Userma'etrēc-setepenrēc (Ramesses II) in the domain of Amūn, etc., temp. Ramesses II, two block-statues, with naos of Rēc-Ḥarakhti, CG 604, and with naos of Osiris, CG 606. Id. ib. ii, Bl. 109, 110, pp. 154-5, 155-6; HORNEMANN, *Types*, ii, pls. 455, 457. CG 604, ROEDER, *Die ägyptische Götterwelt*, Taf. 6. Texts, PIEHL, *Inscr. hiéro.* 3 Sér. lxxviii-lxxix [M, L]; parts, DE ROUGÉ, *Inscr. hiéro.* pl. xxx [middle and top]. Text of CG 604, MARIETTE, *Mon. div.* pl. 63 [f]. See MASPERO, *Guide*, p. 191 [753].

Nebneḥḥ Head of bowmen, and woman Bakert (cursive writing), Songstress of Amūn, seated double-statue, Dyn. XIX, CG 597. BORCHARDT, *Statuen*, ii, Bl. 107, pp. 150-1; HORNEMANN, *Types*, v, pl. 1211.

Late Period.

A headless Prophet of the Temple of Apis, Prophet of Ptah, etc., holding figure of Ptah, CG 667. See BORCHARDT, *Statuen*, iii, pp. 14-15; HASSAN, *The Great Sphinx and its Secrets*, p. 307 [28164].

Wooden bust, CG 731. BORCHARDT, op. cit. Bl. 135, p. 65.

Chicago, Oriental Institute.

Female offering-bringer with basket, Middle Kingdom, No. 10744.

Copenhagen, Nationalmuseet.

Itisen $\overline{\text{It}} \overline{\text{It}} \overline{\text{It}}$, Inspector of *ka*-servants, Scribe (represented twice), seated, and boy Khenu $\overline{\text{Kh}} \overline{\text{Kh}} \overline{\text{Kh}}$, statue-group, late Dyn. V, AA.b.27 (perhaps companion-piece to Leyden Mus. Inv.AST.9). MOGENSEN, *Inscriptions hiéroglyphiques du Musée National de Copenhague*, pl. i, p. 1; *Antiksamlingen, Vejledning for Besøgende* (1935), p. 8 [5] with fig.; KOEFOED-PETERSEN, *Et Ægyptisk Billedværk fra Pyramidetiden in Fra Nationalmuseets Arbejdsmark* (1941), fig. 1, pp. 60-4; *Guide. Oriental and Classical Antiquity* (1950), pl. 1, p. 16 [6]; Louisiana. 5000 års, No. 56 with fig.; BUHL, *Orientalia før 1851 in Copenhague, Mus. Nat. Antik-Cabinetet 1851* (1951), fig. 14, pp. 188-91; id. *A Hundred Masterpieces from The Ancient Near East*, No. 12; *Egypt and Western Asia* (1968), pl. on p. 14, cf. pp. 18-19 [6]; MICHALOWSKI, *Art*, fig. 218 (as Ny Carlsberg Glypt.). Boy Khenu, BUHL in *Nationalmuseets Arbejdsmark* (1960), fig. 5, p. 42. Names and titles, LIEBLEIN, *Dict.* No. 1362; id. *Die aegyptischen Denkmäler* [etc.], Taf. xvii [1], pp. 80-1 [78]. See SCHMIDT (V.), *Østerlandske Indskrifter fra den Kongelige Antiksamling* (1879), p. 23.

Florence, Museo Archeologico.

Ptahmosi $\overline{\text{Pt}} \overline{\text{Pt}} \overline{\text{Pt}}$, Greatest of the directors of craftsmen, etc., temp. Amenophis III, son of Menkheper, First prophet, dedicated by Pahemneter $\overline{\text{Ph}} \overline{\text{Ph}} \overline{\text{Ph}}$, Greatest of the directors of craftsmen, son of Maḥu(y) $\overline{\text{Ma}} \overline{\text{Ma}} \overline{\text{Ma}}$, probably during Dyn. XIX, block-statue, No. 1790. MINTO, *Il Regio Museo Archeologico di Firenze*, fig. on p. 22 [upper left]; BOSSE-GRIFFITHS in *J.E.A.* 41 (1955), pl. xv [left], p. 60 [B]; CAROTTI, *L'Arte*, fig. 265; ALINARI photo. 31114. Text, HELCK, *Urk.* iv. 1917-19 [711], cf. *Übersetz.* (1961), pp. 317-18; GELL MSS. ii. 22 [left top and bottom, right], 22 verso [right]. Names and titles, LIEBLEIN, *Dict.* No. 1931. Filiation of deceased and dedication, FARINA in *Sphinx*, xxi (1924), pp. 24 [6], cf. 25. See SCHIAPARELLI, *Mus. Arch. Firenze*, pp. 197-200 [1505] (text); MIGLIARINI, *Indication*, pp. 46-7; PELLEGRINI in *Bessarione*, 2 Ser. v (1903), pp. 202-3 [2]; ANTHES in *Ä.Z.* 72 (1936), p. 62 [5a].

Leyden Museum.

Mertiotes $\overline{\text{Me}} \overline{\text{Me}} \overline{\text{Me}}$, King's adorer, Overseer of the *is*-chamber of hairdressing, etc. (woman, represented twice), and boy Khenu, Inspector of *ka*-servants, etc., statue-group, late Dyn. V, Inv.AST.9 (formerly in Anastasi Colln., perhaps companion piece to Copenhagen, Nationalmuseet, AA.b.27). LEEEMANS, *Aeg. Mon.* ii, pl. xxii; BOESER, *Beschreibung*, i, Taf. xxiv; CAPART, *Recueil*, i, pls. iv, v; id. *Memphis*, fig. 143; BREMMER, *Eg. kunst*, No. 3; FECHHEIMER, *Plastik*, Taf. 21; *Gids* (1926), fig. on p. 15; (1928), fig. on p. 16; (1937), fig. on p. 19; VAN WIJNGAARDEN in *Oudheid. Med.* n.r. xvii (1936), figs. 1, 2, pp. 1-8; id. *Meesterwerken*, pls. 10-13; KOEFOED-PETERSEN, *Et Ægyptisk Billedværk fra Pyramidetiden in Fra*

Nationalmuseets Arbejdsmark (1941), fig. 2, p. 64; PIJOÁN, *Summa Artis*, iii (1945), fig. 130; BYVANCK, *De Kunst*, pl. xviii [68]; SHOUKRY, *Privatgrabstatue*, Abb. 35, p. 154; HORNE-MANN, *Types*, v, pl. 1386; Amsterdam. 5000 jaar, fig. 12 [28]; KLASENS, *Egyptische kunst*, pl. 1; *Artefact*, pl. 32, p. 32; MICHALOWSKI, *Art*, fig. 222. Head of woman, PETRIE, *History*, i (1923), fig. 35; id. *Arts and Crafts*, fig. 23 facing p. 33; MURRAY, *Sculpture*, pl. ix [3]. Text, *Oostersch Genootschap in Nederland . . . Achtste Congres . . . 1936*, p. 26; GARDINER Notebook, 57, p. 11 [bottom]. See LEEMANS, *Descr. rais.* p. 59 [D.125]; BOESER, *Cat.* (1907), pp. 29-30 [4]; SCHARFF in *J.E.A.* 26 (1940), p. 48.

Seated statue, Dyn. V, Inv.AST.12. BOESER, *Beschreibung*, i, Taf. xxvi; CAPART, *Recueil*, i, pl. viii; *Gids* (1926), fig. on p. 57; (1928), fig. on p. 63; (1937), fig. on p. 83; (1953), figs. 4, 5; STRÖMBOM, *Egyptens Konst*, fig. 40; VAN WIJNGAARDEN, *Meesterwerken*, pls. 14, 15; PIJOÁN, *Summa Artis*, iii (1945), fig. 181; *Artefact*, pl. 31, p. 32. See LEEMANS, *Descr. rais.* pp. 57-8 [D.96]; BOESER, *Cat.* (1907), p. 29 [3].

Scribe-statue, granite, Dyn. V, Inv.AST.31. BOESER, *Beschreibung*, i, Taf. xxv; LEEMANS, *Aeg. Mon.* ii, pl. v [D.20]; *Gids* (1928), fig. on p. 13; (1937), fig. on p. 15; (1953), figs. 3, 6; BREMMER, *Eg. kunst*, No. 5; DE BUCK, *Egyptische Verhalen*, pl. facing p. 32; VAN WIJNGAARDEN, *Meesterwerken*, pls. 8, 9; BYVANCK, *De Kunst*, pl. xvii [62]; RANKE, *The Art of Ancient Egypt*, and BREASTED, *Geschichte Aegyptens* (1936), 63; GILBERT, *Couleurs de l'Égypte Ancienne*, pl. 7; KLASENS, *Egyptische kunst*, pl. 13; HORNEMANN, *Types*, ii, pl. 411 (as AST. 3); *Artefact*, pl. 30, p. 32. See LEEMANS, *Descr. rais.* p. 50 [D.20]; BOESER, *Cat.* (1907), p. 30 [5].

Ptahmosi, God's father of Ptaḥ, son of Yuyu , God's father, and Mutnefert, fragmentary block-statue with figure of Ptaḥ(?) at front, basalt, temp. Ramesses II, Inv.AST. 23. LEEMANS, *Aeg. Mon.* ii, pl. xi [D.45]. Text, BOESER, *Beschreibung*, v, pp. 10-11 [24]. Some names and titles, SCHIAPARELLI, *Mus. Arch. Firenze*, pp. 328-9 (with cartouche); LIEBLEIN, *Dict.* No. 2540. See LEEMANS, *Descr. rais.* p. 53 [D.45]; BOESER, *Cat.* (1907), p. 53 [4].



London, British Museum.

Bezmosi , Boat-builder, etc., seated, granite, Dyn. III, No. 171 (formerly in Salt Colln.). ARUNDALE and BONOMI, *Gallery of Antiquities Selected from the British Museum*, pl. 50 [177]; WEILL, *La II^e et la III^e dynasties*, pl. i, pp. 255-7; *Guide, Eg. Collns.* (1909), fig. on p. 26 [left]; (1930), fig. 9; (1964), fig. 63; BUDGE, *Egyptian Sculptures in the British Museum* (1914), pl. i; id. *The Mummy* (1925), pl. iv [left]; SCHÄFER and ANDRAE, *Kunst* (1925), 217 [right]; (1930 and 1942), 225 [right] (cast); SCHARFF, *Grundzüge der ägyptischen Vorgeschichte in Morgenland*, 12 (1927), Taf. 14 [b] (cast), p. 63; id. in *J.E.A.* 26 (1940), pl. viii [3], p. 46; HALL, *Egypt in Encyclopaedia Britannica*, 14th ed. (1929), pl. ix [4]; ROSS, *The Art of Egypt*, pl. on p. 100 [4]; SCHÄFER, *Das altägyptische Bildnis*, Taf. 1 [b] (cast); RAGAI, *L'Art*, pl. 6 [17] (marked 18), p. 64; SMITH, *Hist. Eg. Sculp.* pl. 3 [d], p. 16 with note 1; id. *Art . . . Anc. Eg.* pl. 21 [B], pp. 37-8; WOLF, *Kunst*, Abb. 95; RUFFLE, *Heritage of the Pharaohs*, fig. 32; WILKINSON MSS. iii. 3 [right], 5 [upper right]. Text, *Hiero. Texts*, vi, pl. 19 [upper left]. See *Sotheby Sale Cat.* (SALT), June 29-July 8, 1835, No. 711 (repr. ATHANASI, *A Brief Account*); SHARPE, *Eg. Antiq.* pp. 8-9 [70]; *Guide (Sculpture)*, p. 2 [3].

Neferhy , Tenant of the Great House, seated, Dyn. III-IV (Budge) or later, No. 24714. BUDGE, *The Mummy* (1925), pl. iv [middle]; id. *A History of Egypt*, ii, fig. on p. 135; PEET in HAMMERTON, *Universal History of the World*, i, fig. on p. 496 [middle]; *Guide, 3rd and 4th*, p. 90 [150] with fig.; *4th to 6th*, p. 119 [1] with fig.; *Eg. Collns.* (1909), fig. on p. 26 [right]; (1930), fig. 10.

Head, Dyn. IV or later, No. 13346. *The Cambridge Ancient History. Plates*, i (1927), pl. on p. 83 [a]; RAGAI, *L'Art*, pl. vii [A]; see *Guide, 4th to 6th*, p. 119 [4].

Marseilles, Musée d'archéologie.

Naos-shaped pedestal, lower part of seated statue, probably of deified King Teti-merneptah (i.e. Teti of Dyn. VI), and headless Amenwahsu , Scribe of the altar of the Lord of the Two Lands, and wife Henutwezebu , Songstress of Amün, kneeling, with scenes of both adoring Teti in his Pyramid in relief on sides of pedestal, Dyn. XIX, No. 211. CAPART, *Recueil*, i, pl. xlv. Texts and scenes on sides of pedestal, NAVILLE in *A.Z.* xvi (1878), Taf. iv, pp. 69-72. Names and titles, LIEBLEIN, *Dict.* No. 2086. See MASPERO, *Catalogue du Musée égyptien de Marseille* (1889), pp. 10-11 [11].

Moscow, State Pushkin Museum of Fine Arts.



Statuette of boy, Dyn. V-VI, I.1.a.5577 (formerly in Golenishchev Colln. 3195). MAL'MBERG and TURAEV, *Opisanie egipetskago sobraniya*, i. *Statui i statuetki Golenishchevskago sobraniya*, pl. ii [3], p. 11 [8].

Munich, Staatliche Sammlung Ägyptischer Kunst.



Ipi , Flutist of the Great House, etc., Dyn. VI, ÄS 1600 (formerly in von Bissing Colln.). *Äg. Sammlung* (1966), Abb. 16; *Staatl. Sammlung* (1972), pl. 18 [left], p. 41; (1976), pp. 52-3 with fig.; BARTA, *Das Selbstzeugnis eines altägyptischen Künstlers*, Taf. xxi; HICKMANN in *Cahiers d'Hist. Ég. Sér. vi* [5, 6] (1954), figs. 3, 4, p. 263; upper part, id. in BLUME, *Die Musik in Geschichte und Gegenwart*, Abb. 31, col. 327.

Kneeling man with lute, Old Kingdom, Gl. 107 (formerly in von Bissing Colln., now lost). WOLTERS and VON BISSING in *Münchner Jahrb.* (1913), Abb. 3a, 3b, p. 159.

Head from block-statue, diorite (often called granite), Dyn. VI, ÄS 5570. MÜLLER (H. W.), *Ein Kopf von einem frühen Würfelhocker* [etc.] in *Festgabe für Dr. Walter Will* (1966), Taf. i, ii, pp. 121-41; id. *Äg. Kunst*, Abb. 49; *Äg. Sammlung* (1966), Abb. 33A (as Dyn. XII); *Staatl. Sammlung* (1972), pl. 19 [upper], p. 43; (1976), p. 55 with fig. on p. 54. See MÜLLER (H. W.) in *Münchner Jahrbuch*, 3 Ser. xxi (1970), p. 181.

Seba , Scribe, Director of all works, etc., and wife Wert-khenreti , Sistrum-player of Amen-rē, seated, double-statue with scene on back panel, Dyn. XIX, Gl. WAF.33. VON BISSING, *Die Kultur des alten Ägyptens*, Taf. 5 [9]; SPIEGELBERG, *Ägyptologische Mitteilungen in Sitzungsberichte der Bayerischen Akademie der Wissenschaften*, Philos.-philol. und hist. Kl. (1925), 2. Abhand. Taf. ii, iii, pp. 17-20 [B]; PIJOÁN, *Summa Artis*, iii (1945), fig. 582; *Schaetze altaegyptischer Kunst. Kunsthalle, Basel, 27. Juni-13. Sept. 1953*, 19th Abb., p. 51 [126]; *Äg. Sammlung* (1966), Abb. 58; *Staatl. Sammlung* (1972), pl. 43, pp. 80-1; (1976), p. 128 with figs.; SEYFFARTH MSS. iii. 2970-80. Scene on back panel, NESTOR L'HÔTE MSS. 20414, 2nd carton, C (squeeze). Names and titles, LIEBLEIN, *Dict.* No. 1211. See LAUTH, *Erklärendes Verzeichniss* [etc.] (1865), pp. 42-3 [24]; FURTWÄGLER, *Beschreibung* [etc.] (1910), pp. 37-8 [37]; WOLTERS, *Illus. Kat.* p. 13 [37]; id. *Führer*, p. 10 [37].

New York, Metropolitan Museum of Art.

Demez , Overseer of the desert, Overseer of royal fortresses, etc., seated, and wife Henutsen , Prophetess of Hathor and Neith, etc., double-statue, dedicated by son Ty (perhaps owner of tomb No. 60 [D 22]), Dyn. V, No. 51.37. SCOTT in *M.M.A. Bull.* n.s. xi (Dec. 1952), figs. on pp. 117, 119, cf. pp. 116-18; MICHALOWSKI, *Art*, fig. 221.

Man in long garment, inscribed, Dyn. XII, No. 66.123.1 (formerly in Hilton Price Colln.). HILTON PRICE, *A Catalogue of the Egyptian Antiquities* [etc.], ii (1908), pl. xxi [4707], p. 79; *Sotheby Sale Cat.* May 20–21, 1930, pl. iv [281], p. 31; FISCHER in *M.M.A. Bull.* n.s. xxv (Oct. 1967), fig. on p. 76; MASTAI in *The Connoisseur*, clxiii (1966), fig. on p. 278; *Gazette des Beaux-Arts*, lxxix (1967), Supp. Feb. 1967, fig. 206; LILYQUIST in *The Metropolitan Museum of Art. Notable Acquisitions 1965–1975*, fig. on p. 71 [bottom]; SIMPSON, *The Face of Egypt: Permanence and Change in Egyptian Art*, No. 7 with fig. See *Sotheby Sale Cat.* (HILTON-PRICE), July 12–21, 1911, p. 10 [77].

Northampton, Central Museum and Art Gallery.

Sekhemka (same man as Brooklyn 37.23E) seated, holding papyrus with offering-list, with wife(?) Sitmert  kneeling by his right leg, and in relief, son(?) Seshemnûfer, Scribe of the house of the master of the largesse, on seat by his left leg, and offering-bringers on sides and back, late Dyn. V. JAMES in *J.E.A.* 49 (1963), pls. i, ii, fig. 1, pp. 5–9, 12; ALDRED, *Egypt*, fig. 124; YOYOTTE, *Treasures*, pl. on p. 35; SWAN HALL in *Apollo*, lxxxvii (1968), fig. 11, p. 167.

Oxford, Ashmolean Museum.

Head of youth, probably Dyn. XX, No. 1872.87. See CHESTER, *Catalogue of the Egyptian Antiquities in the Ashmolean Museum, Oxford* (1881), p. 2 [23].

Paris, Louvre.



Ptahshepses seated, early Dyn. V, A 108 [N.113]. ARCHIVES phot. E.535. See DE ROUGÉ, *Notice des monuments* (1883), p. 50; BOREUX, *Guide*, ii, p. 451; VANDIER, *Guide* (1948 and 1952), p. 36; (1973), p. 70.

Thenti  Secretary of the Toilet-house, etc., seated, Dyn. IV–V, E.10776. ROSS, *The Art of Egypt*, pl. on p. 100 [3]; HORNEMANN, *Types*, iii, pl. 688. See BOREUX, *Guide*, ii, p. 450; VANDIER, *Guide* (1948), p. 10; (1952), p. 11; (1973), p. 17.



Scribe-statue, Dyn. V, A 42 [N.43]. CLARAC, *Musée de Sculpture* [etc.], v, pl. 997 [2558D], *Texte*, v, p. 302. Head, RICHER, *Le Nu*, fig. 66. See DE ROUGÉ, *Notice des monuments* (1883), p. 28; BOREUX, *Guide*, i, p. 242; VANDIER, *Guide* (1948), p. 9; (1952), p. 9 note 1, and p. 10; (1973), p. 16.

Seated female statue, Dyn. V–VI, A 109 [N.114]. *Id. Manuel*, iii, pl. xv [5], p. 573; ARCHIVES phot. E.536. See DE ROUGÉ, *Notice des monuments* (1883), p. 50; BOREUX, *Guide*, ii, p. 450; VANDIER, *Guide* (1948 and 1952), p. 8; (1973), p. 9.

Two, man moulding cakes, and woman squatting beside grinding stone, Dyn. V, E.7704, 7704bis. BREASTED (Jr.), *Eg. Servant Statues*, pls. 26 [d], 25 [d], pp. 26–7 [3], 24–5 [1]; HORNEMANN, *Types*, iii, pl. 654; iv, pl. 1006. E.7704, PIJOÁN, *Summa Artis*, iii (1945), fig. 233; ROSS, *The Art of Egypt*, pl. on p. 109 [1]; VANDIER and SOUGEZ, *La Sculpture égyptienne au Musée du Louvre*, 10th pl. [lower]; LEEK in *J.E.A.* 58 (1972), pl. xxx [2] between pp. 128–9; ARCHIVES phot. E.377. See BOREUX, *Guide*, ii, p. 468; VANDIER, *Guide* (1948 and 1952), p. 36 [near top]; (1973), p. 69.

Yuyu  Custodian of the Treasury, son of Ria  (mother), and wife(?) Ty  seated, double-statue, sandstone, probably temp. Tuthmosis IV, A 116 [E.5343]. VANDIER, *Manuel*, iii, pl. cxliii [4], p. 672; MICHALOWSKI, *Art*, fig. 497; DESROCHES-NOBLECOURT in *La Revue du Louvre*, xxvi (1976), figs. 11, 12, p. 91; ARCHIVES phot. E.677. Text, PIERRET, *Rec. inscr.* i, pp. 32–6; and scene, DEVÉRIA squeezes, 6170 C, 8. Names and titles, LIEBLEIN, *Dict.* No. 2179. See LENORMANT, *Description des antiquités . . . collection . . .*

Raifé (1867), No. 2; DE ROUGÉ, *Notice des monuments* (1883), p. 52; BOREUX, *Guide*, ii, pp. 453-4; VANDIER, *Guide* (1948), p. 63 [near bottom]; (1952), p. 64 [lower]; (1973), p. 118.

Paḥemneter ], Greatest of the directors of craftsmen, etc., and Hori ], Governor of the town, Vizier, etc., both seated, double-statue, late Dyn. XIX-XX, A 72. CAPART, *Recueil*, pl. xli; BOREUX, *Guide*, i, pl. iv, p. 55; VANDIER, *Manuel*, iii, pl. cxlv [6], p. 672; MICHALOWSKI, *Art*, fig. 536; ARCHIVES phot. E.54. Text, PIEHL, *Inscr. hiéro.* I Sér. xvi [B]-xvii [2nd col.]; some, PIERRET, *Rec. inscr.* ii, pp. 58-9. Names and titles, LIEBLEIN, *Dict.* No. 2051. See DE ROUGÉ, *Notice des monuments* (1883), p. 38; VANDIER, *Guide* (1948), p. 22; (1952), p. 23; (1973), p. 38.

Paris, Musée Rodin.

Ptaḥhotp, son of Di-iaut ], as scribe, with wife Ēsiwert kneeling, quartzite, early Dyn. XXVI, No. 90. See *Rodin collectionneur. Musée Rodin, Paris, 1967-1968*, No. 27; BOTHMER, *Eg. Sculp.* p. 36.

Philadelphia, Pennsylvania University Museum.

Khenu, Sole companion, Dyn. V, E 14301.

Providence, Rhode Island School of Design.

Male wooden bust, partly restored, 1st Int. Period or early Middle Kingdom, No. 25.031. L. E. R[OWE] in *Bulletin of the Rhode Island School of Design*, xv (1927), fig. on p. 1, cf. pp. 2-3 (as Dyn. V); BANKS in *ib.* xxv (1937), fig. on p. 35 (as Dyn. V); DORNER and BANKS in *ib.* xxvii [1] (July 1939), fig. on p. 13, cf. p. 26 (as Dyn. XI); GODRON in *Bull. Soc. fr. d'Ég.* No. 11 (Oct. 1952), fig. 1, p. 64.

Stockholm, Medelhavsmuseet.

Two similar heads, probably Dyn. V, MM.10224 (in *Bibl.* iii.² 304 but more likely from here) and MME 1974:143.

Nude male wooden statue, legs lost, late Old Kingdom, MM.11410. See Stockholm. *5000 år*, No. 29.

Strasbourg, Univ. Inst. d'Égyptologie.

Male and female heads, probably from double-statue, Dyn. V-VI, Nos. 963-4. SPIEGELBERG, *Ausgewählte Kunst-Denkmäler der Aegyptischen Sammlung (Strassburg)*, Taf. iii [5, 6], p. 4. See BUCHER and LECLANT in *Bulletin. Société Académique du Bas-Rhin*, n.s. lvii-lx (1953-6), p. 104; *Antiquités égyptiennes* (Strasbourg, Exposition . . . 12 juillet-15 octobre 1973), p. 33 [103-4].

Private collections, dealers, etc.

Kneeling statuette, Dyn. III, in New York, Royal-Athena Galleries. EISENBERG, *A Catalog of Egyptian and other Near Eastern Antiquities*, No. 42 (1962), No. 1 with figs.; *id.* *Art of the Ancient World*, i, Cat. No. 44, Dec. 1965, No. 57 with fig. on p. 28.

Upper part of male statue, diorite, Dyn. IV (Eisenberg) or later, in New York, Royal-Athena Galleries. *Id.* *A Catalog of Egyptian and other Near Eastern Antiquities*, No. 42 (1962), No. 2 with fig.; *Egyptian . . . Antiquities (Royal-Athena Galleries)*, Parke-Bernet Galleries, *Sale Cat.* (April 29-30, 1964), p. 35 [172] with fig.

'Ankh-hor  (probably), Sole companion, Secretary of the Toilet-house, Dyn. V, found in 1864. Sketches of head and base, VASSALLI MSS. 10.



Male wooden statuette, wrapped in linen, Dyn. VI, formerly in Hilton Price and Hearst Collns. HILTON PRICE, *A Catalogue of the Egyptian Antiquities* [etc.], i (1887), p. 369 [3105] with fig. See *Sotheby Sale Cat.* (HILTON-PRICE), July 12-21, 1911, p. 101 [800]; ib. (HEARST), July 11-12, 1939, No. 139.

Two male wooden statuettes, Dyn. VI, formerly in Hilton Price Colln. HILTON PRICE, op. cit. pp. 368 [3103], 370 [3106], with figs. No. 3103, *Sotheby Sale Cat.* (HILTON-PRICE), July 12-21, 1911, pl. xx [798], p. 101. No. 3106, see ib. p. 101 [799].

Male head, sandstone, middle Dyn. XVIII, in New York, Royal-Athena Galleries. EISENBERG, *A Catalog of Egyptian and other Near Eastern Antiquities*, No. 42 (1962), No. 3 with fig.

Nefertemhotp , Overseer of prophets, etc., and wife, fragment of double-statue, diorite, Dyn. XIX. See *Sotheby Sale Cat.* May 14-15, 1956, p. 17 [134, 1st item].

Fragment of granite statue wearing elaborate necklace, inscribed, probably New Kingdom. MURRAY, *Saqqara Mastabas*, i, pl. xxxvi [2, 3], p. 3.

Niche with statues(?) of Sipair , Head of the stable of His Majesty, etc., son of 'Aḥmosi  (mother), with son Kharuef  libating and censing, New Kingdom. Sketch and texts, WILKINSON MSS. vii. 49.

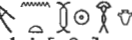

False-doors and stelae

Baltimore, Walters Art Gallery.

Merneit-weḥebrēc , son of Psammethek, Dyn. XXVI-XXVII, No. 22.123. STEINDORFF, *Cat.* pl. xlvi [285], pp. 85-6; MUNRO, *Die spätägyptischen Totenstelen*, Taf. 59 [202], p. 333.

Berlin (East), Ägyptisches Museum.





Old Kingdom, 1st Int. Period, and Middle Kingdom.

Meru , Elder of the house, and wife Neferthes , Prophetess of [Hathor], panel, Dyn. V, No. 7767. Text, *Aeg. Inschr.* i, p. 38. See *Ausf. Verz.* p. 60; *Führer* (1961), p. 43.

Benuiu , Secretary of the God's treasure, fragment, 1st Int. Period, No. 14333. Text, *Aeg. Inschr.* i, p. 121. Name, RANKE in *A.Z.* 78 (1942), p. 54.

Ptaḥshepses , Supervisor of the Treasury assessing Upper and Lower Egypt and all foreign countries, etc., rectangular stela, probably early Middle Kingdom, No. 7779. VANDIER, *Manuel*, ii, fig. 290 [upper right], p. 465. Texts, BRUGSCH, *Thes.* 1484-6 [142] (with sketches); *Aeg. Inschr.* i, p. 120. Some names and titles, LIEBLEIN, *Dict.* No. 1384. See *Ausf. Verz.* p. 72.

New Kingdom.



Iuti , Outline-draughtsman of Rēc, son of Niay  and Wernuro , and wife Nezem(t)-mennüfer , Ramesside, No. 7269 (formerly in Passalacqua Colln.). Deceased and wife kneeling in middle register, SACHS, *Die Musik-instrumente des alten Ägyptens*, Abb. 30 on p. 32. Text, *Aeg. Inschr.* ii, pp. 194, 196-7. Some names and titles, LIEBLEIN, *Dict.* No. 1168. See PASSALACQUA, *Cat. raisonné*, pp. 47-8 [1364]; *Ausf. Verz.* p. 166.



Kama , Sectional chief of the new poultry-yards of the Temple of Ptah, Ramesside, No. 7289 (formerly in Passalacqua Colln.). Text, *Aeg. Inschr.* ii, pp. 164-5. See PASSALACQUA, op. cit. pp. 64-5 [1391]; *Ausf. Verz.* p. 168.

Khafy , Washerman, probably Dyn. XVIII, No. 7314 (formerly in Passalacqua Colln.). Text, *Aeg. Inschr.* ii, pp. 152-3. See PASSALACQUA, op. cit. p. 66 [1395]; *Ausf. Verz.* p. 165.

Khafy, Head of custodians of the Lord of the Two Lands, and wife Hēnutwezeb , Songstress of Hathor Mistress of Heliopolis, Dyn. XIX, No. 7281 (formerly in Passalacqua Colln.). ERMAN, *Die ägyptische Religion* (1909), fig. 95; id. *Die Religion der Ägypter*, fig. 103; BONNET, *Reallexikon der ägyptischen Religionsgeschichte*, Abb. 64 on p. 261; *Gudar och människor vid Nilen* (Göteborg, 18 mars-20 maj 1973), No. 324 with pl. 20; Kunstmuseet i Ateneum Helsingfors. *Det eviga Egypten. Aegyptus aeterna* (1973), No. 102 with fig. 6; Sofia. *Izložbha Vechniyat Egipet* (1975), No. 15 at the beginning with fig.; Szépművészeti Múzeum, Budapest. *Egyiptomi művészet* [etc.] (1975), No. 43 with fig. 31. Lower register, BRUIJNING in *Anc. Eg.* (1922), fig. 15, pp. 6-7. Text, *Aeg. Inschr.* ii, pp. 163-4. Names and titles, LIEBLEIN, *Dict.* No. 743. See PASSALACQUA, op. cit. pp. 48-9 [1366]; *Ausf. Verz.* p. 168.

Merenptah , Hereditary prince, *sem*-priest, etc., probably Dyn. XVIII, No. 7276 (formerly in Passalacqua Colln.). Text, *Aeg. Inschr.* ii, pp. 106-7. Name and titles, LIEBLEIN, *Dict.* No. 910. See PASSALACQUA, op. cit. p. 48 [1365]; *Ausf. Verz.* p. 159.

Meryptah , Goldworker of the Lord of the Two Lands, and wife(?) Nubemwaskhet , Dyn. XVIII, No. 7279 (formerly in Passalacqua Colln.). Text, *Aeg. Inschr.* ii, pp. 145-7. Names and titles, LIEBLEIN, *Dict.* No. 741. See PASSALACQUA, op. cit. pp. 69-70 [1400]; *Ausf. Verz.* p. 167.



Neheheniotef , Servant, and wife Mutemwia , Dyn. XIX, No. 7273 (formerly in Passalacqua Colln.). Szépművészeti Múzeum, Budapest. *Egyiptomi művészet* [etc.] (1975), No. 101 with fig. 33. Wife with sistrum, SACHS, *Die Musikinstrumente des alten Ägyptens*, Abb. 29 on p. 32. Texts, *Aeg. Inschr.* ii, pp. 150-2. Names and titles, LIEBLEIN, *Dict.* No. 1171. See PASSALACQUA, op. cit. pp. 59-60 [1384]; *Ausf. Verz.* p. 165; *Führer* (1961), p. 67.



Panehesi , Scribe of the altar of the royal apartments, late Dyn. XVIII, No. 7317 (formerly in Passalacqua Colln.). BRUGSCH, *Monumens de l'Égypte* (1857), pl. iii; REINISCH, *Aegyptische Chrestomathie*, Taf. 15. Text, *Aeg. Inschr.* ii, pp. 139-42. Names and titles, LIEBLEIN, *Dict.* No. 748. See PASSALACQUA, op. cit. p. 54 [1375]; *Ausf. Verz.* p. 161.



Penamün, Head of custodians of documents of the Temple, and wife Taysiry , Songstress of Amün, Dyn. XIX-XX, No. 7307 (formerly in Passalacqua Colln.). Muzeul de artă, Bucharest. *Egiptul antic* [etc.] (1975), No. 17 with fig. on p. 16 [right lower]. Upper part of wife in upper register, SACHS, op. cit. Abb. 28 on p. 31. Text, *Aeg. Inschr.* ii, pp. 148-50. See PASSALACQUA, op. cit. pp. 60-1 [1386]; *Ausf. Verz.* p. 165; *Führer* (1961), p. 67.

Ptahmosi, Brewer of the Temple of Ptah, son of Neh(yt)  (mother), Dyn. XVIII, No. 7321 (formerly in Passalacqua Colln.). Text, *Aeg. Inschr.* ii, pp. 167-9. Names and titles, LIEBLEIN, *Dict.* No. 733. See PASSALACQUA, op. cit. pp. 50-1 [1370]; *Ausf. Verz.* p. 168.

Ra'mosi, Head of bowmen of the Lord of the Two Lands, Royal scribe, etc., probably late Dyn. XVIII or early Dyn. XIX, No. 7306 (formerly in Passalacqua Colln.). SCHARFF, *Götter Ägyptens*, Taf. 9; *Egyptian Mythology*, fig. on p. 81 [lower] (text incomplete). Text, *Aeg. Inschr.* ii, pp. 131-3. See PASSALACQUA, op. cit. p. 52 [1372]; *Ausf. Verz.* pp. 162-3.

Seba , Scribe of divine offerings of the Temple of Ptaḥ, etc., son of Kenna  and Maḥu , Dyn. XVIII, No. 7315 (formerly in Passalacqua Colln.). Text, *Aeg. Inschr.* ii, pp. 172-3. Names and titles, LIEBLEIN, *Dict.* No. 966. Four baboons adoring sun, ERMAN, *Die ägyptische Religion* (1909), fig. 9; id. *Die Religion der Ägypter* (1934), fig. 8. See PASSALACQUA, op. cit. pp. 62-3 [1389]; *Ausf. Verz.* p. 167.



Si , Scribe of documents of the Chief Steward, and wife Beti , and Senen-dḥout  and wife Ḥenut, Dyn. XVIII, No. 7272 (formerly in Passalacqua Colln.). Text, *Aeg. Inschr.* ii, pp. 109-10. Names and titles, LIEBLEIN, *Dict.* No. 739. See PASSALACQUA, op. cit. pp. 67-8 [1397]; *Ausf. Verz.* pp. 158-9.

Tawer(t)  and Nubkhet(?) , women, Dyn. XVIII, No. 7318 (formerly in Passalacqua Colln.). Text, *Aeg. Inschr.* ii, p. 201. Names, LIEBLEIN, *Dict.* No. 747. See PASSALACQUA, op. cit. pp. 68-9 [1399]; *Ausf. Verz.* pp. 168-9.

Wepwautmosi , Overseer of the Two Granaries of Upper and Lower Egypt, etc., end of Dyn. XVIII, No. 7316 (formerly in Passalacqua Colln.). *Aeg. und Vorderasiat. Alterthümer*, Taf. 25; ERMAN and RANKE, *Aegypten und aegyptisches Leben im Altertum* (1923), Taf. 23 [3]; *Ausf. Verz.* Abb. 34, pp. 161-2. Text, *Aeg. Inschr.* ii, pp. 134-6. See PASSALACQUA, op. cit. pp. 52-3 [1373]; *Führer* (1961), p. 66.



Late Period and Ptolemaic.

Imḥōtep, son of Pefu , Dyn. XXVI-XXVII, No. 7304 (formerly in Passalacqua Colln.). ERMAN, *Die ägyptische Religion* (1905), fig. 131; (1909), fig. 134; id. *Die Religion der Ägypter*, fig. 157; MUNRO, *Die spätägyptischen Totenstelen*, Taf. 60 [203], p. 334; texts and sketches, WILKINSON MSS. ii. 52 B verso [middle]. Two names, LIEBLEIN, *Dict.* No. 1312. See PASSALACQUA, op. cit. pp. 53-4 [1374]; *Ausf. Verz.* pp. 336-7.

Pedepap , Judge, son of Estary(t)enḥor  and Amenardais, probably Ptolemaic, No. 7308 (formerly in Passalacqua Colln.). Text, PIEHL in *P.S.B.A.* x (1888), pp. 534-5 [9]; xi (1889), p. 77. Names and titles, LIEBLEIN, *Dict.* No. 1059. See PASSALACQUA, op. cit. p. 51 [1371]; *Ausf. Verz.* p. 236.

Unidentified in East Berlin or lost.

Emnūfer , and wife Ipet , New Kingdom, No. 12748. Text, *Aeg. Inschr.* ii, pp. 214-15. See *Ausf. Verz.* p. 157.



Minmosi , Overseer of the cattle of Amūn, and wife Mia  and others, wood, Dyn. XVIII, No. 822 (formerly in Passalacqua Colln.). *Aeg. und Vorderasiat. Alterthümer*, Taf. 106. Text, *Aeg. Inschr.* ii, p. 99. See PASSALACQUA, *Cat. raisonné*, pp. 70-1 [1401]; *Ausf. Verz.* p. 159.

Thaiḥepimu, with hieroglyphic and Carian texts, Dyn. XXVI-XXVII, No. 21615. EILERS in *Z.D.M.G.* 94, N.F. 19 (1940), Abb. 3 facing p. 203, cf. p. 230; MASSON and YOYOTTE, *Objets pharaoniques à inscription carienne*, pl. iv [a], fig. 17, pp. 31-5. See MUNRO, *Die spätägyptischen Totenstelen*, p. 331.

Abeh and wife Akhetbu , with hieroglyphic and Aramaic texts, year 4 of Xerxes I, No. 7707. LEPSIUS in *Ä.Z.* xv (1877), Taf. i, pp. 127-32; BURCHARDT in ib. xlix (1911), Taf. viii [2], pp. 73-4; *Aeg. und Vorderasiat. Alterthümer*, Taf. 123; VON BISSING in *Z.D.M.G.* 84, N.F. 9 (1930), Taf. 2 [2], p. 230; ERMAN, *Die ägyptische Religion* (1905), fig. 121; (1909), fig. 124; id. *Die Religion der Ägypter* (1934), fig. 121. See *Ausf. Verz.* p. 266.

Bologna, Museo Civico.

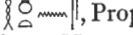
Simery , Inspector of the most select of those who are in attendance, etc., and



mother Henutsen , Prophetess of Neith, etc., dedicated by father Werkaptah , end of Dyn. V or later, No. 1901. FISCHER, *Varia*, pls. i–ii [1, 2], figs. 3–5, pp. 3–17; CURTO, *L'Egitto antico* (1961), Tav. 12 [4], pp. 66–8. Upper part, PETRIE ITAL. photo. 8. Mother on right inner jamb, BRESCIANI, *La collezione egizia nel Museo Civico di Bologna*, Tav. 3, pp. 24–6. See KMINEK-SZEDLO, *Catalogo di Antichità Egizie*, pp. 177–8 (some texts); DUCATI, *Guida*, p. 48 [E].



Brooklyn Museum.

Itehi , Dyn. V, No. 37.107E (formerly in Abbott and N.Y. Hist. Soc. Collns.). Text, JAMES, *Corpus*, i, pl. xxii [50], p. 19. See *N.Y.H.S. Cat.* p. 9 [136].



Neferka , *wab*-priest of the Pyramid of Sahurê, Overseer of scribes of the crews, etc., Dyn. V, No. 37.33E (formerly with dealer Masarra and in Abbott and N.Y. Hist. Soc. Collns.). Texts, JAMES, op. cit. pl. xxi [41], pp. 15–16; *L. D. Text*, i, p. 17 [middle, 1–3]; WILKINSON MSS. xx.A.3 [bottom], 4 A [top], xxiii. 77 [right middle, and bottom], xli. 38 [bottom left], 43 verso [bottom left]. See *N.Y.H.S. Cat.* pp. 10–11 [152] (as Dahshûr).

Amenemhêt, son of Shabt , (mother), Dyn. XII, No. 37.1346E (formerly in N.Y. Hist. Soc. Colln.). Texts, JAMES, op. cit. pls. xxxi [86], cf. vi, p. 38. Two people before deceased and wife in lower part, RIEFSTAHL, *People of the Black Land, Egypt*, Ser. i, No. 4, 2nd fig. See *N.Y.H.S. Cat.* p. 9 [137].



Heku , Porter of the Temple, and son Ptaḥwenenef , with name of Nefertem , Sculptor, at bottom, Dyn. XII, No. 37.1347E (formerly in N.Y. Hist. Soc. Colln.). COONEY in *Brooklyn Mus. Bull.* xii [2] (Winter 1951), fig. 1, pp. 1–4. Text, JAMES, op. cit. pl. xxxviii [133], pp. 56–7. See *N.Y.H.S. Cat.* p. 8 [120].



Ptaḥnemti , Steward, and Si-ipy , Overseer of the store-room, and others, Dyn. XII, No. 37.1345E (formerly in N.Y. Hist. Soc. Colln.). Text, JAMES, op. cit. pl. xxxvi [115], pp. 50–1. See *N.Y.H.S. Cat.* p. 8 [117].

Penamûn , Great overseer of craftsmen, and wife Mutemwia, late Dyn. XVIII, No. 37.1486E (formerly in N.Y. Hist. Soc. Colln.). JAMES, op. cit. pls. xiii [434], lxxxvi, pp. 177–8. See *N.Y.H.S. Cat.* p. 13 [179]; WERBROUCK, *Pleureuses*, p. 91.

Userpehtinesu(?) , Iy'adru(?) , and woman Panûter , early Dyn. XVIII, No. 37.1353E (formerly in N.Y. Hist. Soc. Colln.). Text, JAMES, op. cit. pl. xlv [165], p. 71. See *N.Y.H.S. Cat.* p. 13 [178].

Brussels, Mus. Roy. d'Art et d'Hist.

Nefershemem , *mitrt* (woman), wife of Neferen , Overseer of the store-room, lower part, Dyn. III (Speleers) or later, E.1835. Sketch, WEILL, *La II^e et la III^e dynasties*, p. 317 [2] with fig.; SPELEERS, *Rec. inscr.* p. 6 [40] (as Giza). See SMITH (W. S.) in REISNER, *Tomb Development*, p. 397.

Pedeneit , son of Pedeḥor and Thes-ḥap-pert , Sistrum-player of Ḥathor Mistress of the Southern Sycamore, Dyn. XXVI, E.7429. DE MEULENAERE in *Chron. d'Ég.* xlvi (1973), fig. 1, pp. 47–51.

Cairo Museum.



Old Kingdom and 1st Int. Period.



ʿAnkhmaʿnemti , Overseer of bleachers of linen, etc., Dyn. V–VI, CG 1508. BORCHARDT, *Denkmäler*, i, Bl. 44, pp. 213–14.



Hem(t)rēc , Prophetess of Hathor Mistress of the Sycamore, and of Neith, etc., Dyn. VI, CG 1524. Text, id. ib. p. 225. Name and titles, LIEBLEIN, *Dict.* No. 83. See MARIETTE, *Notice des principaux monuments . . . à Boulaq* (1864), p. 213 [5].

Irenes , Lector-priest of the endowment, Dyn. VI or 1st Int. Period, CG 1400. BORCHARDT, op. cit. Bl. 16, p. 61; VANDIER, *Manuel*, ii, fig. 277 [lower right], p. 404.



Irensen , Overseer of miners, Prophet of Horus and Sēth foremost of the divine monument, etc., panel, probably Dyn. IV, CG 1391. BORCHARDT, op. cit. Bl. 13, p. 52. See SMITH (W. S.) in REISNER, *Tomb Development*, p. 398.



Kauza , Inspector of physicians, etc., and wife Wertka , Dyn. V, CG 1398. BORCHARDT, op. cit. Bl. 15, pp. 58-9; VANDIER, op. cit. fig. 282 [right], p. 424.



Khuenptah , Supervisor of the store-rooms, and woman Meresankh , Overseer of the store-room, fragment, Dyn. V, CG 1513. Text, BORCHARDT, op. cit. p. 217.

Mes-sa , Chief lector-priest, Scribe of divine books, etc., and daughter Neferhetpes , panel and adjoining palace-façade, perhaps Dyn. IV, CG 1422. Id. ib. Bl. 23, pp. 102-3; VANDIER, op. cit. fig. 282 [left], p. 426.

Nebsen , Lector-priest, etc., Dyn. VI, CG 1527. Text, BORCHARDT, op. cit. p. 227.

Nefert-wenenes , Royal acquaintance (woman), probably part of false-door, dedicated by grandson Isi , Overseer of the Treasury, Scribe of the royal documents, Dyn. IV, CG 1394. Id. ib. Bl. 14, pp. 54-5; FISCHER in *Metropolitan Museum Journal*, 8 (1973), fig. 13, p. 15. Dedication, SETHE, *Urk.* i. 228 [5 (145), E].

Neternūfer , Overseer of the ten of the Great Bark, Overseer of the King's *wabt*, etc., and wife Neferhetpes , Royal acquaintance, with statue in niche, Dyn. VI, CG 1447. BORCHARDT, op. cit. Bl. 33, pp. 130-2; MASPERO in GRÉBAUT, *Le Musée Égyptien*, i, pl. xxiv, pp. 23-4; VANDIER, op. cit. fig. 279 [upper right], p. 411. Lower part, PETRIE Gīza photo. 554. Text, DARESSY in *Rec. Trav.* xi (1889), p. 82 [xxvii]. See MASPERO, *Guide*, p. 48 [86].

Pepysonb , Irenes , Judge and Overseer of scribes, etc., Dyn. VI, CG 1412. Text, BORCHARDT, *Denkmäler*, i, pp. 77-8.



Sab , Prophet of the shrine of Sēth, Overseer of linen (*sšrw*), etc., two panels of probably same man, late Old Kingdom, CG 1715-16. Id. ib. ii, Bl. 92, pp. 152-3.

Sitsen , (woman), 1st Int. Period, CG 1446. Id. ib. i, Bl. 32, pp. 129-30.

Teti , Tenant, Overseer of the ten, etc., Dyn. VI, CG 57188.

Middle Kingdom.

Methu , Royal chamberlain, Judge and Overseer of scribes, etc., probably Middle Kingdom, CG 1397. BORCHARDT, *Denkmäler*, i, Bl. 15, pp. 56-7. Name and some titles, DE ROUGÉ, *Inscr. hiéro.* pl. xcix [bottom].

Tathet , (also ) King's wife, perhaps Middle Kingdom, CG 1425. BORCHARDT, op. cit. Bl. 24, pp. 106-8. Text, DARESSY in *Rec. Trav.* xi (1889), pp. 82-3 [xxviii].



New Kingdom.

Aḥmosi, Scribe of the counting of cattle of the house of the Overseer of the seal, and wife Puḥu , Dyn. XVIII, CG 34049. LACAU, *Stèles*, pl. xxix, pp. 84-6; MARIETTE, *Mon. div.* pl. 56 [left]; MASPERO, *Guide* (1883), pl. facing p. 38; VANDIER, *Manuel*, ii, fig. 301 [upper right], p. 504; VASSALLI MSS. 15 [right].

Amenemḥab, Head of goldworkers of the Lord of the Two Lands, and wife 'Ati ,

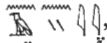

Dyn. XIX. MASPERO, *Guide* (1883), pl. facing p. 39; POERTNER, *Die ägyptischen Totenstelen* [etc.], Taf. iii, pp. 84-5. Names and titles, LIEBLEIN, *Dict.* No. 750; of deceased, DE ROUGÉ, *Inscr. hiéro.* pl. xxxiii [middle].



Amenmosi, Head of quartermasters of the army, and wife Nany , probably temp. Amenophis III, CG 34054. LACAU, *Stèles*, pl. xxxii, pp. 95-7; SCHÄFER, *Äg. Kunst*, fig. on p. 21 [4]. Names and titles, LIEBLEIN, *Dict.* Nos. 627, 2025; some, DE ROUGÉ, op. cit. pl. lvi [top right]. See BOGOSLOVSKAYA in *Tutankhamon i ego vremya* (1976), pp. 53-4.



Huy , Head of  of the Temple of the Aten, and wife Nezem(t)-mennüfer , temp. Amenophis IV, CG 34182. LACAU, op. cit. pl. lxix, pp. 222-4; MARIETTE, *Mon. div.* pl. 56 [right]. Texts (variously complete), SANDMAN, *Texts from the Time of Akhenaten*, pp. 178-9 [ccxii]; HELCK, *Urk.* iv. 2022 [768], cf. *Übersetz.* (1961), p. 363; DE ROUGÉ, op. cit. pl. liv [middle]. Names and titles, LEGRAIN, *Répertoire*, No. 265; some, LIEBLEIN, *Dict.* No. 622. See *Guide* (1883), pp. 41-2 [169].



Kasa , Chief door-opener of the stone door, and wife Hetept, Dyn. XIX, JE 8778. BAKRY in *Ann. Serv.* lvii (1962), pls. ii, iii, pp. 10-14. Some text, DE ROUGÉ, op. cit. pl. xxxiii [top]. Names and titles, LIEBLEIN, *Dict.* No. 992.



Kha'emwëset Kiauia , as harpist, Dyn. XIX, JE 18922. HICKMANN, *Ägypten*, Abb. 120.

May , Overseer of magazines of Peru-nüfer, and wife Ruiu , Dyn. XVIII, CG 34050. LACAU, *Stèles*, pl. xxx, pp. 86-90. Man libating in 2nd register, DRIOTON in *Mon. Piot*, xxv (1921-2), fig. 6, p. 127. Text, PIEHL, *Inscr. hiéro.* 3 Sér. xciii-xcv [K]; HELCK, *Urk.* iv. 1504-6 [476], cf. *Übersetz.* (1961), pp. 130-1. Names and titles, LIEBLEIN, *Dict.* No. 938; LEGRAIN, *Répertoire*, No. 280.



Minhotp , Heteptu , Scribe of the Treasury, etc., and wife Mut , fragmentary, temp. Amenophis II, Temp. No. 18.12.19.1. Texts, DARESSY in *Ann. Serv.* xix (1920), pp. 127-30; HELCK, *Urk.* iv. 1512-14 [484], cf. *Übersetz.* (1961), pp. 134-6.

Nehem'tay , Head of bowmen, Head of the stable, etc., and wife Ta'aty , probably temp. Amenophis III, CG 34098. LACAU, *Stèles*, pl. xlvi, pp. 151-2; VASSALLI MSS. 16 [right]. Names and titles, DE ROUGÉ, *Inscr. hiéro.* pl. lii [middle] (as Abydos); LIEBLEIN, *Dict.* No. 628; LEGRAIN, *Répertoire*, No. 281.

Nemtimosi , Charioteer of His Majesty, and wife Èsinefert , Dyn. XIX, Temp. No. 22.1.21.1. MARIETTE, *Mon. div.* pl. 105. Name and title, id. *Mastabas*, p. 3.

Para'hirwenemef , Great scribe of the accounting of Amün, etc., son of Merenptah , and wife Nehy(t) , Songstress of Amün, probably Dyn. XX, JE 3299. MARIETTE, *Mon. div.* pl. 61; DEVÉRIA squeezes, 6196, 10. Deceased and wife seated, DRIOTON and HASSIA, *Temples and Treasures of Egypt in Art et style* (1954), pl. 18. Text, PIEHL, *Inscr. hiéro.* 1 Sér. xlii-xliv [B]. Names and titles, LIEBLEIN, *Dict.* No. 927, *Suppl.* p. 975.

Piay , Head of bowmen and  of the Temple of Merneptah, lower part, temp. Merneptah or later, JE 38539. CAIRO, CENTRE OF DOCUMENTATION photos. S.A., 23-4, 33.

Suti , Head of sailors of Ma'et, and wife Tawer(t)-hetepti , probably Dyn. XIX, JE 8781. VASSALLI MSS. 22 [right]. Names and titles, LIEBLEIN, *Dict.* No. 931, *Suppl.* p. 975.





Fragment with text concerning foreign tribute, Dyn. XVIII, JE 28569. MÜLLER (W. M.), *Egyptological Researches*, i, pls. 14, 15, p. 24; GABALLA in *J.E.A.* 63 (1977), pls. xxii, xxiii, pp. 122-4.

Late Period.



Hor, son of Pedehorenpe, Dyn. XXVI, JE 22110. See MUNRO, *Die spätägyptischen Totenstelen*, p. 330.

Pefteu, Dyn. XXVI, JE 28684. Id. ib. p. 330.



Ptolemaic.

ʿAnemho Pasekhem , son of Paḥemmeter  Pedeharemḥab , both *wnrw*-priests in Letopolis, etc., and Nebuzat , hieroglyphic and demotic texts, temp. Ptolemy XII Neos Dionysos, CG 31099. SPIEGELBERG, *Die demotischen Inschriften*, Taf. vi, pp. 28–33. Texts, BRUGSCH, *Thes.* 889–96. Hieroglyphic text, and 1st line of demotic, MARIETTE, *Mastabas*, pp. 460–1 [upper]. Names and titles, LIEBLEIN, *Dict.* No. 1084. See MUNRO, *Die spätägyptischen Totenstelen*, p. 337; QUAEGBEUR in *Ancient Society*, 3 (1972), pp. 106–7 [3.4]; id. in *Chron. d'Ég.* xlix (1974), p. 64 [5].



Deryn(?) , Prophet of Horus-Khentekhtai Lord of Athribis, etc., son of Deryn (?) and Herʿankh Heraḳer (i.e. Herakleia), probably temp. Ptolemy IX Soter II, CG 22137. KAMAL, op. cit. pl. xl, pp. 119–20. Text, DARESSY in *Rec. Trav.* xvi (1894), p. 49 [civ]. See MUNRO, op. cit. pp. 336–7; DE MEULENAERE in *Chron. d'Ég.* xxxvii (1962), pp. 73–5; QUAEGBEUR in ib. xlix (1974), p. 63 [3].

Herakleria (i.e. Herakleia) , Herʿankh , Prophetess of Horus-Khentekhtai Lord of Athribis, daughter of Ubasteiyti  (mother), year 39 (of Ptolemy VIII Euergetes II), CG 22179. KAMAL, *Stèles Ptolémaïques et Romaines (Cat. Caire)*, pl. lii, pp. 157–8. Text, DARESSY in *Rec. Trav.* xvi (1894), p. 49 [ciii]. See MUNRO, op. cit. p. 337, cf. Taf. 62 [214] (from KAMAL); QUAEGBEUR in *Chron. d'Ég.* xlix (1974), p. 63 [4].

Paḥemmeter (Pedeharemḥab), son of Heru , hieroglyphic and demotic texts, year 18 of Ptolemy X Alexander I, CG 31103. Texts, DE ROUGÉ, *Inscr. hiéro.* pl. ccclii [upper left, and lower]; hieroglyphic, and 1st line of demotic, MARIETTE, *Mastabas*, p. 462; hieroglyphic, SPIEGELBERG, *Die demotischen Inschriften*, pp. 36–8 (sketch). See MUNRO, op. cit. p. 337; QUAEGBEUR in *Chron. d'Ég.* xlix (1974), p. 64 [6]; WILDUNG, *Imhotep und Amenhotep*, p. 62 [39].

Pedubaste, *warb*-priest of the Temples of Memphis, etc., son of Khaḥap  and Taḥetre , hieroglyphic and demotic texts, late Ptolemaic (year 16), CG 31136. SPIEGELBERG, op. cit. Taf. xv, p. 53. See QUAEGBEUR in *Chron. d'Ég.* xlix (1974), p. 64 [7].

Cambridge, Fitzwilliam Museum.



Senbuy , Greatest of the directors of craftsmen, etc., with wife Nubemḥab  and son Reḳ-set , 2nd Int. Period, E.SS.37.

Chicago, Field Museum of Natural History.

Nefertere (woman), with scene before Apis-bull in lower register, Ramesside, A.31652. ALLEN, *Egyptian Stelae in Field Museum of Natural History*, pl. xiv, pp. 35–6.

Chicago, Oriental Institute.

Bensi , Inspector of an estate of Neferkarē, Greatest of leather-craftsmen, etc., 1st Int. Period, No. 10490. BROVARSKI in *J.N.E.S.* 32 (1973), fig. 1, cf. 4, pp. 453–65 (suggesting Abydos).

Khenu-ib , Supervisor of the Two Houses, and woman Ḥenutsen , *mitri*, fragment, Dyn. V–VI, No. 10813 (formerly in Bircher Colln.).

Sebeky , Treasurer of the God, Dyn. VI, No. 11049. See BAER, *Rank and Title in the Old Kingdom*, p. 122 [434].



Copenhagen, Nationalmuseet.

Idy , two jambs, Dyn. VI, AA.d.18, 19. NIEBUHR, *Reisebeschreibung nach Arabien* [etc.] (1774), i, pl. xl [E]; id. *Voyage en Arabie* [etc.] (1776), i, pl. xl [E] facing p. 167; BUHL, *Orientalia for 1851 in Copenhagen, Mus. Nat. Antik-Cabinetet 1851* (1951), fig. 8, p. 184; id. *A Hundred Masterpieces from The Ancient Near East*, No. 7. Texts, MOGENSEN, *Inscriptions hiéroglyphiques du Musée National de Copenhague*, p. 11 [lower]; some, SCHMIDT (V.), *Textes hiéroglyphiques . . . du Musée de Copenhague*, p. 2. See id. *Østerlandske Indskrifter fra den Kongelige Antiksamling* (1879), p. 8; *Guide. Oriental and Classical Antiquity* (1950), p. 16 [7] (confused with 8).

Copenhagen, Ny Carlsberg Glyptothek.

‘Ankhwezes , Stonemason of the King, lower part, Dyn. VI, Æ.I.N. 942. SCHMIDT, *Levende og Døde*, figs. 112, 113; id. *Choix* (1910), pl. v [7, 8], p. 14; SLOMANN in *Bulletins et Mémoires de la Société d'Anthropologie de Paris* (1927), pl. i, pp. 62-3; MOGENSEN, *Coll. ég.* pl. xcvi [A 678], p. 90; KOEFOED-PETERSEN, *Cat. des bas-reliefs*, pls. xvii, xviii, pp. 20-1 [12], 70. Deceased on right jamb, SCHMIDT, *Den Æg. Sam.* (1908), pp. 67-70 [E.29] with fig.; MADSEN in *Å.Z.* 42 (1905), Abb. 1, pp. 65-6, 69; TOLSTOÏ, *Étude des Représentations Pathologiques dans l'Art Égyptien*, fig. 6, pp. 73-5; WOLF, *Kunst*, Abb. 212; LECA, *Médecine*, fig. 53. Texts, KOEFOED-PETERSEN, *Rec. inscr.* p. 30 [942].



Isi , Overseer of the Treasury, etc., probably Dyn. IV, panel of false-door and two wall-fragments, Æ.I.N. 896. MOGENSEN, *Coll. ég.* pl. xciii [A 670-2], pp. 89-90; KOEFOED-PETERSEN, *Cat. des bas-reliefs*, pl. xxiv, pp. 24-5 [17, 18], 71; id. *Rec. inscr.* pls. i-iii. See SCHMIDT, *Den Æg. Sam.* (1908), pp. 63-4 [E.17-19], cf. pl. 2 (text of panel). Offering-lists, HASSAN, *Giza*, vi [2], pls. clviii-clxxxiii [153, cf. 156-7], p. 154.

Iywen , Sekhentiuka , King's *warb*-priest, Keeper of the writing material of the King, and wife Thentet , Dyn. V, Æ.I.N. 943. SCHMIDT, *Choix* (1910), pl. v [9], p. 15; MOGENSEN, *Coll. Ég.* pl. xcvi [A 679], p. 90; KOEFOED-PETERSEN, *Cat. des bas-reliefs*, pl. xvi, pp. 19-20 [11], 69-70. Texts, id. *Rec. inscr.* p. 33 [943]. See SCHMIDT, *Den Æg. Sam.* (1908), pp. 70-2 [E.30].

Ni'ankh-irty-pepy , Steward, Director of the dining hall, etc., probably end of Old Kingdom, Æ.I.N. 22. Text, KOEFOED-PETERSEN, *Rec. inscr.* p. 38 [22]; PETRIE in SAYCE MSS. 25a [left]. See SCHMIDT, *Den Æg. Sam.* (1908), p. 74 [E.35].

Seshemuka , Tenant of the Great House, Keeper of the dining-room(?) of the royal repast of the Great House, lower part, Dyn. V, Æ.I.N. 9-12. MOGENSEN, *Coll. ég.* pl. xciv [A 674], p. 90; KOEFOED-PETERSEN, *Cat. des bas-reliefs*, pl. xx, pp. 21-2 [13], 70. Texts, id. *Rec. inscr.* p. 31 [9-12]. See SCHMIDT, *Den Æg. Sam.* (1908), pp. 65-6 [E.21-4].

Lintel with offering-text, Dyn. V, Æ.I.N. 8. MOGENSEN, *Coll. ég.* pl. xciii [A 668, called 688], p. 89; KOEFOED-PETERSEN, *Cat. des bas-reliefs*, pl. xxix [28], p. 29. Text, SCHMIDT, *Den. Æg. Sam.* (1908), pl. 13 [2], pp. 64-5 [E.20].

Imu , (woman) and husband Petetheb , upper part, Middle Kingdom, Æ.I.N. 15. KOEFOED-PETERSEN, *Les stèles égyptiennes*, pl. 23, pp. xxix, 22. Text, id. *Rec. inscr.* p. 39 [15]; PETRIE in SAYCE MSS. 25a [right]. See SCHMIDT, *Den Æg. Sam.* (1908), p. 99 [E.55].

Durham, Univ. Gulbenkian Museum.

Amenemḥab Pakharu , Head of retainers, two registers, I, Tia (tomb, see *supra*) and wife before Osiris and Isis, II, deceased and son before Ḥathor-cow image, temp. Ramesses II, N.1965. MÁLEK in *J.E.A.* 60 (1974), pl. xxxiv, fig. 1, pp. 162-5. Texts of jambs and lintel, WILKINSON MSS. xx. C.12 [lower left]; xxv. 12 verso. See BIRCH, *Catalogue of the Collection of Egyptian Antiquities at Alnwick Castle*, pp. 304-7.

Florence, Museo Archeologico.

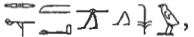

Amenemḥab and wife Ḥunay , probably temp. Amenophis III, No. 2592. BOSTICCO, *Le stele egiziane del Nuovo Regno*, fig. 31, pp. 36-8 [31]; ALINARI photo. 43833. Text, SCHIAPARELLI, *Mus. arch. Firenze*, pp. 303-5 [1577]; BEREND, *Principaux monuments*, p. 90. Some names and titles, LIEBLEIN, *Dict.* No. 774, *Suppl.* p. 969. See ROSELLINI, *Breve Notizia degli Oggetti di Antichità Egiziane* [etc.] (1830), p. 73 [87]; MIGLIARINI, *Indication*, pp. 35-6; BOGOSLOVSKAYA in *Tutankhamon i ego vremya* (1976), p. 61, cf. fig. on p. 62.

Minmessu , Deputy of Memphis, and wife Sitamün, middle Dyn. XVIII, No. 2538. BOSTICCO, op. cit. fig. 28, pp. 35-6 [29]. Texts, SCHIAPARELLI, op. cit. pp. 301-2 [1576]; BEREND, op. cit. p. 50. See ROSELLINI, op. cit. pp. 29-30 [18]; MIGLIARINI, op. cit. p. 13.

Ptaḥmay , Head of chariot-makers, middle Dyn. XVIII, No. 2584. MINTO, *Il Regio Museo Archeologico di Firenze*, fig. on p. 38 [lower right]; BOSTICCO, op. cit. fig. 29, pp. 33-5 [28]; ALINARI photo. 43827. Text, SCHIAPARELLI, op. cit. pp. 290-2 [1568]; BEREND, op. cit. p. 82. Names and titles, LIEBLEIN, *Dict.* No. 653, *Suppl.* p. 963; BRUGSCH, *Thes.* 1446 [59]. See MIGLIARINI, op. cit. pp. 31-2; PELLEGRINI in *Bessarione*, 2nd Ser. v (1903), pp. 199-200 [8].

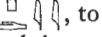
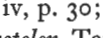
Sebkḥotp, Custodian of the Temple of 'Akheperkarē (Tuthmosis I), etc., and wife Rennutet , early Dyn. XVIII, No. 2589. BOSTICCO, op. cit. fig. 22, pp. 29-31 [22]; ALINARI photo. 43830; SEYFFARTH MSS. iii. 3158. Text, SCHIAPARELLI, op. cit. pp. 286-8 [1566]; BEREND, op. cit. p. 87. Some names and titles, BRUGSCH, *Thes.* 1446 [58]; LIEBLEIN, *Dict.* No. 316, *Suppl.* p. 946; SETHE, *Urk.* iv. 129 [50, E]. See MIGLIARINI, op. cit. pp. 34-5.



Man before Osiris and Ḥathor, and text concerning sale of tomb by Pedetaihet , *wḥ*-priest, son of Ipdy , to Amenir(t)erau(?) , year 4 of Psammetikhos I, No. 2507. BEREND, op. cit. pl. iv, p. 30; SCHIAPARELLI, op. cit. Tav. vii, p. 375 [1639]; MUNRO, *Die spätägyptischen Totenstelen*, Taf. 59 [196], pp. 328-9; BOSTICCO, *Le stele egiziane di Epoca Tarda*, fig. 14, pp. 24-6 [14]; PETRIE ITAL. photo. 383 [left]. Text, MALININE in *Rev. d'Ég.* 27 (1975), pp. 164-8. See ROSELLINI, op. cit. p. 39 [40]; MIGLIARINI, op. cit. p. 65.

Psammethek, Inspector of *sem*-priests of the Temple of Ptaḥ South of his Wall, etc., son of Gemneḥarbak , and Tharet , born year 3 of Necho II, died year 35 of Amasis, No. 2551. ROSELLINI, *Mon. Stor.* clii, *Text*, ii, pl. x [B], p. 132; BOSTICCO, op. cit. fig. 15, pp. 26-8 [15]; ALINARI photo. 43809 [right middle]. Text, BEREND, op. cit. pp. 58-9; SCHIAPARELLI, op. cit. pp. 376-8 [1640]. Names, LIEBLEIN, *Dict.* No. 2351. See ROSELLINI, *Breve Notizia degli Oggetti di Antichità Egiziane* [etc.] (1830), p. 60 [71]; MIGLIARINI, op. cit. p. 21; MUNRO, *Die spätägyptischen Totenstelen*, p. 329.

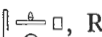
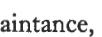

Hanover, Kestner-Museum.

Seḥotp , Royal acquaintance, and wife Ipi , *mitrt*, etc., probably late Old



Kingdom, No. 1935.200.48 (formerly in The Hague, Scheurleer Mus.). VON BISSING in *Bull. Antieke Beschaving*, vi [1] (June 1931), fig. 1, pp. 23-5; id. *Äg. Kunstgeschichte*, Taf. lvii [362], *Text*, ii, pp. 31 note 7, 76 note 1, 169 (as Dyn. III). See SCHARFF in *Studies presented to F. Ll. Griffith*, p. 357 note 3.

Shepi  They , Lector-priest, Steward, Dyn. VI, No. 1956.24. WOLDERING, *Ausgewählte Werke der ägyptischen Sammlung* (1958), pl. 14; id. *Meisterwerke des Kestner-Museums zu Hannover* (1961), Abb. 5; id. *Kestner-Museum 1889-1964*, p. 40 [10] with fig.

Istanbul, Archaeological Museum.

Ny , *warb*-priest, Head of , and wife Teri , Dyn. XVIII, No. 10864. PÖRTNER, *Ägyptische Grabsteine und Denksteine aus Athen und Konstantinopel*, Taf. vi [19], p. 6. *Text*, MASPERO in *Ä.Z.* xx (1882), pp. 120-2 [xxi]; SCHEIL in *Rec. Trav.* xv (1893), p. 197 [2].

Lausanne, Musée cantonal d'archéologie et d'histoire.

Psammethek-*a(u)neit* , son of Wehebrē-*neb[ken]* , with hieroglyphic and Carian texts, Dyn. XXVI-XXVII, No. 4727 (formerly in Prince Napoleon Colln.). MASSON and YOYOTTE, *Objets pharaoniques à inscription carienne*, pl. ii, figs. 13, 14, pp. 20-7 [F], with bibliography of the Carian text. See FROEHNER, *Catalogue d'une collection d'antiquités* (1868), p. 207 [526].

Leyden Museum.

Abneb , Overseer of the Palace, etc., alabaster niche-stela, Dyn. III, Inv.AM.10. BOESER, *Beschreibung*, i, Taf. xxiii; CAPART, *Recueil*, i, pl. i; *Gids* (1928), fig. on p. 64; (1937), fig. on p. 78; (1953), fig. 1; STRÖMBOM, *Egyptens Konst*, fig. 59; SCHÄFER and ANDRAE, *Kunst* (1942), 248 [upper]; VAN WIJNGAARDEN, *Meesterwerken*, pl. 6; WOLF, *Die Welt der Ägypter*, Taf. 20 [upper]; KLASSENS, *Egyptische kunst*, pl. 11; *Artefact*, pl. 28, pp. 31-2. See LEEEMANS, *Descr. rais.* pp. 298-9 [V.121]; BOESER, *Cat.* (1907), p. 30 [6].

'Ankhesni , King's sole adorer, Prophetess of Hathor, 1st Int. Period, F. 1970/5.2. *Christie Sale Cat.* April 14, 1970, pls. facing pp. 37, 38 [120], cf. p. 37 (as Dendera); SCHNEIDER in *Oudheidkundige Mededelingen*, lii (1971), pl. iii [2], fig. 2, pp. 11-13. See KLASSENS in *Nederlandse Rijksmusea*, xcii (1970), p. 262.

Fefi , Overseer of directors, 1st Int. Period, F.1970/5.1. SCHNEIDER, *op. cit.* pl. iii [1], fig. 1, pp. 10-11. See KLASSENS, *op. cit.* p. 262.

Zehō, *warb*-priest of the Temples of Memphis, Scribe of Ptolemy II Philadelphus, III Evergetes I, IV Philopator, and V Epiphanes, etc., hieroglyphic and demotic, F.1955/7.1. DE MEULENAERE in *Oudheidkundige Mededelingen*, xlv (1963), pl. v, pp. 5-7. See MUNRO, *Die spätägyptischen Totenstelen*, p. 338 (as F.1939/7.1); QUAEGBEUR in *Chron. d'Ég.* xlix (1974), p. 65 [10].



Liverpool, Merseyside County Museums.

Ni'ankh-tet , Director of scribes of petitions and of scribes of the house of the master of the largesse, etc., niche-stela, probably Dyn. IV, M. 13850 (formerly in J. Sams and J. Mayer Collns.). *Ancient Egypt. Objects . . . in the possession of J. Sams* (1839), 10th pl.; GATTY, *Catalogue of the Mayer Collection*, Pt. 1 (1877), p. 45 [294] with fig.; (1879), pp.



49-50 [294] (not illustrated); MASPERO, *Hist. anc.* i, fig. on p. 250; *Handbook and Guide to the Egyptian Collection* (1932), pl. 3, p. 55 [8]. See EDWARDS (A. B.) in *Rec. Trav.* x (1888), p. 130 [1]; SMITH (W. S.) in REISNER, *Tomb Development*, p. 398.

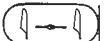

London, British Museum.

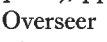
Old Kingdom and 1st Int. Period.

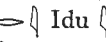
Isi'ankh  , Secretary of the King in all his secrets, *sma*-priest of Horus, etc., middle Dyn. V or later, No. 1383. *Hiero. Texts*, i, pl. 24; i², pl. xix, p. 18; *Guide, Eg. Collns.* (1909), pl. xiv facing p. 167; (1930), fig. 135 on p. 251; VAN DER LEEUW, *De Godsdienst van het oude Aegypte*, pl. 44 facing p. 81; HAAS, *Bilderatlas zur Religionsgeschichte*, fig. 111. See *Guide (Sculpture)*, pp. 18-19 [53].

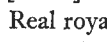
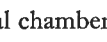
Khubau  , Overseer of tenants, Scribe of a boat's side, etc., 1st Int. Period, No. 128. *Hiero. Texts*, i, pl. 41 [86]; i², pl. xxxiv [2], p. 36; BROVARSKI in *J.N.E.S.* 32 (1973), fig. 2, cf. 4, p. 458 (suggesting Abydos); WILLIAMS rubbings, iv. 90-1. Text, CRUM in GARDINER Notebook, 54, p. 23 [lower]. See *Guide (Sculpture)*, pp. 26-7 [86].

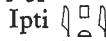
Meri   Idu  , Real royal chamberlain, Scribe of the royal documents, etc., Dyn. VI, No. 1191. *Hiero. Texts*, i, pl. 33 [85]; i², pl. xxxv [1], p. 37. See *Guide (Sculpture)*, p. 26 [85].

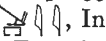
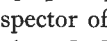

Ptaḥhotp Ipti  , Royal chamberlain, Lector-priest, etc., Dyn. VI or later, No. 1287. *Hiero. Texts*, i, pl. 33 [82]; i², pl. xxxix [1], p. 41. See *Guide (Sculpture)*, pp. 25-6 [82].

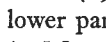
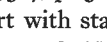
Shenaty  , Inspector of the Pyramid of Pepy II, etc., temp. Pepy II or later, No. 212. *Hiero. Texts*, i, pl. 45 [79]; i², pl. xxxviii [1], p. 40. See *Guide (Sculpture)*, p. 24 [79]; *Guide, Eg. Collns.* (1930), p. 302.



Teti  , lower part with statue in niche, Dyn. IV-V, No. 1165. *Hiero. Texts*, i, pl. 29 [64]; i², pl. iv [1], p. 4; *Guide (Sculpture)*, fig. on p. 21, cf. p. 20 [64]; BUDGE, *Egyptian Sculptures in the British Museum* (1914), pl. iv.

2nd Int. Period and New Kingdom.

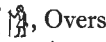
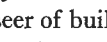

'Aḥmosi, Scribe, son of 'Aḥmosi (mother), 2nd Int. Period, No. 1314. *Hiero. Texts*, v, pl. 17. See *Guide (Sculpture)*, pp. 96-7 [336].



Ḍḥutmosi, Head of custodians of the gate in Memphis, and wife Khaut  , probably temp. Amenophis III, No. 155. *Hiero. Texts*, viii, pl. xxxix, pp. 47-9; SHARPE, *Eg. Inscr.* 1 Ser. 105; *Guide (Sculpture)*, pl. xviii, p. 130 [460]. Text, BUDGE in *Transactions of the Society of Biblical Archaeology*, viii (1885), pp. 320-8. Names and titles, LIEBLEIN, *Dict.* No. 668. See *Sotheby Sale Cat.* (ATHANASI), March 13-20, 1837, No. 983.



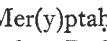

Paser  , Overseer of builders of the Lord of the Two Lands, etc., with brother Tenry (tomb, see *supra*), temp. Ramesses II, No. 165 (formerly in Salt Colln.). SHARPE, op. cit. 1 Ser. 2; *Hiero. Texts*, ix, pls. xxiv, xxiva, pp. 28-9; WILLIAMS rubbings, iii. 44-7. Names and titles, LIEBLEIN, *Dict.* No. 953. See *Sotheby Sale Cat.* (SALT), June 29-July 8, 1835, No. 1124 (as Abydos) (repr. ATHANASI, *A Brief Account*); SHARPE, *Eg. Antiq.* p. 83; *Guide (Sculpture)*, p. 178 [643].





Thuthu  , Steward in the domain of Ay, etc., adoring Sokari, temp. Ay, No. 211 (formerly in Salt Colln.). *Hiero. Texts*, vii, pl. 35; WILLIAMS rubbings, iv. 89. Text, HELCK, *Urk.* iv. 2111 [821], cf. *Übersetz.* (1961), p. 403. Name and titles, LIEBLEIN, *Dict.* No. 615. See *Sotheby Sale Cat.* (SALT), June 29-July 8, 1835, No. 715 (repr. ATHANASI, *A Brief Account*); *Guide (Sculpture)*, p. 124 [439].





Ptolemaic and Roman.





Berentaget  (i.e. Berenice), Sistrum-player of Min Lord of Panopolis, daughter of Mer(y)ptah  and Irsentay  (i.e. Arsinoë), hieroglyphic and demotic texts, late Ptolemaic, No. 383. YOUNG, *Hieroglyphics*, pl. 49. See SHARPE, *Eg. Antiq.* pp. 126-7; *Guide (Sculpture)*, p. 267 [998]; *Guide, Eg. Collns.* (1930), p. 407; QUAEGBEUR in *Ancient Society*, 3 (1972), p. 106 [3.3]; id. in *Chron. d'Ég.* xlix (1974), p. 69 [19].

Esisut  Pedubaste, Greatest of the directors of craftsmen, Prophet of Philotera and Arsinoë [II] (daughters of Ptolemy I Soter), son of Renpetnefer(t)  (mother), hieroglyphic and remains of demotic text, temp. Ptolemy II Philadelphus, No. 379. YOUNG, op. cit. pls. 77-8. Text, BRUGSCH, *Thes.* 907-9 [3]. Sketch, YORKE and LEAKE in *Transactions of the Royal Society of Literature of the United Kingdom*, i, Pt. i (1827), pl. xi [30] (repr. as *Remarks on some Egyptian Monuments in England*). Names and titles, LIEBLEIN, *Dict.* No. 2518. See *Guide (Sculpture)*, p. 276 [1029]; MUNRO, *Die spätägyptischen Totenstelen*, p. 339; QUAEGBEUR in *Chron. d'Ég.* xlix (1974), p. 67 [17].

Har-imhōtep  , *wnrw*-priest in Letopolis, etc., son of 'Ankh-hap , Prophet of Snefru, etc., and Nefertiy(t) , probably temp. Ptolemy III Euergetes I or IV Philopator, Nos. 380 and 26804. No. 380, SHARPE, *Eg. Inscr.* 1 Ser. 27; MUNRO, op. cit. Taf. 61 [208], p. 340; WILLIAMS rubbings, iv. 63; SEYFFARTH MSS. xi. 9674-5, 9688; cartouche of Snefru, LÈEMANS, *Lettre à M. François Salvolini* [etc.] (1838), pl. xxviii [284], p. 141; see SHARPE, *Eg. Antiq.* p. 129; *Guide (Sculpture)*, p. 274 [1025]. Both, see QUAEGBEUR in *Chron. d'Ég.* xlix (1974), pp. 67-8 [18].

Heres'ankh  , Perfect sistrum-player of Min Lord of Panopolis, daughter of Her'ankh  , dedicated by son Esisut, probably temp. Ptolemy II Philadelphus, No. 389. MUNRO, op. cit. Taf. 62 [211], p. 340; WILKINSON MSS. xvii. G 8; WILLIAMS rubbings, iv. 30; SEYFFARTH MSS. xi. 9673. See *Guide (Sculpture)*, pp. 276-7 [1031]; DE MEULENAERE in *Chron. d'Ég.* xxxiv (1959), pp. 245-6; QUAEGBEUR in ib. xlix (1974), p. 69 [21].

Khensiu  , Prophet of Nektanebos II 'the hawk' of the Temple of Tadehnet, etc., son of Esisut , Greatest of the directors of craftsmen, and Renpetnefer(t)  (mother), hieroglyphic and demotic texts, year 37 of Ptolemy II Philadelphus, No. 375. YOUNG, *Hieroglyphics*, pl. 79; MUNRO, op. cit. Taf. 61 [209], p. 339; WILDUNG, *Imhotep und Amenhotep*, p. 51 [27.1] with Taf. ix. Incomplete texts, BRUGSCH, *Thes.* 906 [lower]-907. Sketch, YORKE and LEAKE, op. cit. pl. xi [35]. Names and titles, LIEBLEIN, *Dict.* No. 2517. Title, see DE MEULENAERE in *Chron. d'Ég.* xxxv (1960), p. 94 [4]. See *Guide (Sculpture)*, p. 277 [1032]; GAUTHIER, *Livre des Rois*, iv, p. 232 [xxxviii]; QUAEGBEUR in *Chron. d'Ég.* xlix (1974), pp. 66-7 [14].

Pashenptah  , son of Pedubaste, both Greatest of the directors of craftsmen, and Her'ankh  , year 11 of Cleopatra VII Philopator, 'Harris Stela', No. 886. PRISSE, *Mon.* pl. xxvi; SHARPE, *Eg. Inscr.* 1 Ser. 72-3; REINISCH, *Aegyptische Chrestomathie*, Taf. 21; BUDGE, *The Mummy* (1925), fig. on p. 447 (as No. 147) (text incomplete); id. *From Fetish to God in Ancient Egypt*, fig. on p. 196 (text incomplete); WILDUNG, *Imhotep und Amenhotep*, pp. 65-7 [44] with Taf. xi [left], xii; NESTOR L'HÔTE MSS. 20404, 40-2 (squeeze); HAY MSS. 29844, B; WILLIAMS rubbings, iv. 98-9 [lower], 100-1 (reversed). Scene, MUNRO, op. cit. Taf. 63 [215-16], p. 341. Text, BRUGSCH, *Thes.* 940-4 [10], cf. 879; SEYFFARTH MSS. xi. 9608-9; parts, BRUGSCH, *Dictionnaire Géographique de l'Ancienne Égypte*, p. 67 [lower]; VERCOUTTER in *B.I.F.A.O.* xlvi (1949), p. 179 [lxxxii] (copied by Maystre). See BIRCH in *Archaeologia*, xxxix (1863), pp. 315-32; *Guide (Sculpture)*, p. 275 [1026]; QUAEGBEUR in *Ancient Society*, 3 (1972), pp. 97-9 [2.4]; id. in *Chron. d'Ég.* xlix (1974), p. 70 [25].

Pedubaste $\square \text{𓆎} \text{𓆏}$ Imḥōteḫ, son of Pashenptaḫ, both Greatest of the directors of craftsmen, etc., and Taimḥōteḫ, hieroglyphic and demotic texts, date of death year 22 of Cleopatra VII Philopator, of burial year 7 of Augustus, No. 188. YOUNG, *Hieroglyphics*, pls. 70-1, 74 [upper]; WILDUNG, *Imhotep und Amenhotep*, pp. 70-3 [46] with Taf. x [right], xi [right]; WILKINSON MSS. xvii. G 15 (omitting demotic). Texts, BRUGSCH, *Thes.* 928-33 [8]. See SHARPE, *Eg. Antiq.* p. 128; *Guide (Sculpture)*, p. 276 [1030]; MUNRO, op. cit. p. 339; QUAEGBEUR in *Ancient Society*, 3 (1972), pp. 83-8 [2.1]; id. in *Chron. d'Ég.* xlix (1974), p. 66 [13].

Taimḥōteḫ $\text{𓆎} \text{𓆏} \text{𓆐} \text{𓆑}$, Perfect sistrum-player, daughter of Khaḥap $\text{𓆎} \text{𓆏} \text{𓆐} \text{𓆑}$ and Ḥertankḫ $\text{𓆎} \text{𓆏} \text{𓆐} \text{𓆑}$, and wife of Pashenptaḫ, Greatest of the directors of craftsmen, year 10 of Cleopatra VII Philopator, No. 147. PRISSE, *Mon.* pl. xxvi bis; SHARPE, *Eg. Inscr.* 1 Ser. 4, 5 [upper]; LEPSIUS, *Auswahl*, Taf. xvi [lower]; REINISCH, *Aegyptische Chrestomathie*, Taf. 20; *Guide, Eg. Collns.* (1930), fig. 116, p. 407; WILDUNG, *Imhotep und Amenhotep*, pp. 68-70 [45] with Taf. xiii; SEYFFARTH MSS. xi. 9581-2; WILLIAMS rubbings, iv. 102. Scene, MUNRO, op. cit. Taf. 64 [217], p. 338. Text, BRUGSCH, *Thes.* 918-27 [7]. See SHARPE, *Eg. Antiq.* pp. 128-9; *Guide (Sculpture)*, p. 275 [1027]; *Guide, Eg. Collns.* (1964), p. 91; BIRCH in *Archaeologia*, xxxix (1863), pp. 332-47; MASPERO in *Études égyptiennes*, i, pp. 185-90; ERMAN in *Festschrift Eduard Sachau* (1915), pp. 107-11; QUAEGBEUR in *Ancient Society*, 3 (1972), pp. 93-6 [2.3]; id. in *Chron. d'Ég.* xlix (1974), pp. 65-6 [11].

Taimḥōteḫ $\text{𓆎} \text{𓆏} \text{𓆐} \text{𓆑}$, Perfect sistrum-player of Ptaḫ and Isis foremost of Nent, daughter of Taimḥōteḫ, with hieroglyphic and demotic texts, year 39 (probably of Ptolemy VIII Euergetes II), No. 387. YOUNG, *Hieroglyphics*, pl. 48; MUNRO, op. cit. Taf. 61 [210], p. 340. See SHARPE, *Eg. Antiq.* pp. 129-30 with figs. 66-7; *Guide (Sculpture)*, pp. 275-6 [1028]; DE MEULENAERE, *Le surnom égyptien à la Basse Époque*, p. 23 [78]; QUAEGBEUR in *Ancient Society*, 3 (1972), pp. 105-6 [3.2]; id. in *Chron. d'Ég.* xlix (1974), p. 69 [20].

Taneferḥo $\text{𓆎} \text{𓆏} \text{𓆐} \text{𓆑}$, Perfect sistrum-player of Ptaḫ, daughter of Khaḥap and Ḥertankḫ, hieroglyphic and demotic texts, year 7 of Augustus, No. 184. YOUNG, op. cit. pls. 72-3, 74 [lower]. Omitting demotic, WILKINSON MSS. xvii. G 14. Scene, MUNRO, op. cit. Taf. 64 [218], pp. 338-9. Demotic and some hieroglyphic text, BRUGSCH, *Thes.* 934-40 [9]. See SHARPE, *Eg. Antiq.* p. 127; *Guide (Sculpture)*, p. 264 [983]; QUAEGBEUR in *Ancient Society*, 3 (1972), pp. 88-93 [2.2]; id. in *Chron. d'Ég.* xlix (1974), p. 66 [12].

London, University College Museum.

Bekenmin $\text{𓆎} \text{𓆏} \text{𓆐} \text{𓆑}$, Stonemason, son of Minmosi $\text{𓆎} \text{𓆏} \text{𓆐} \text{𓆑}$ and Tapakhentet $\text{𓆎} \text{𓆏} \text{𓆐} \text{𓆑}$, and wife Tamert $\text{𓆎} \text{𓆏} \text{𓆐} \text{𓆑}$, with large family, Dyn. XIX, No. 14362. CAPART, *Recueil*, i, pl. xliii; STEWART, *Eg. Stelae*, i, pl. 23, pp. 31-2. See *Handbook of Egyptian Antiquities* (1915), No. 538 [1st item].

Khreduankḫ $\text{𓆎} \text{𓆏} \text{𓆐} \text{𓆑}$, Perfect sistrum-player, daughter of Pashenptaḫ, Greatest of the directors of craftsmen, year 9 of Cleopatra VII Philopator, No. 14357. Text, WEIGALL in *Rec. Trav.* xxix (1907), pp. 221-2 [xv]. See QUAEGBEUR in *Ancient Society*, 3 (1972), pp. 99-100 [2.5]; id. in *Chron. d'Ég.* xlix (1974), p. 72 [31].

Manchester, University Museum.

Nikaupḥa $\text{𓆎} \text{𓆏} \text{𓆐} \text{𓆑}$, Prophet of Ṣaḥurēc and of Rēc in the Sun-temple of Userkaf, etc., temp. Ṣaḥurēc or later, No. 10780 (formerly in Cook Colln.). MURRAY in *Anc. Eg.* (1917),

pp. 62-4 [1] with fig. Dedication, SETHE, *Urk.* i. 227 [5 (145), B]. See MENGEDOHT, *Catalogue of the Egyptian Antiquities . . . Collection of Sir Herbert Cook* [etc.] (1924), pp. 13-14 [37].

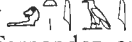

Marseilles, Musée d'archéologie.

Kasa, Royal scribe, Overseer of the army, son of Ḥatiay , Judge, and Ēsi, Dyn. XIX, four oriented stelae, Nos. 240-3 (formerly in Fernandez and Clot Bey Collns.). NAVILLE, *Les quatre stèles orientées du Musée de Marseille* in *Congrès provincial des orientalistes, Lyon, 1878. Compte rendu*, i, pls. xii-xv, pp. 275-93; *Le Nil et la société égyptienne* (Musée Borély, Marseille, 6 décembre-1^{er} mars 1973), Nos. 280-3 with figs.; CAIRO, CENTRE OF DOCUMENTATION photos. S.R., Box 173, 5001, 5021, 5024-5; WILBOUR MSS. iii. D. 28-31. Some texts, WILKINSON MSS. xiii. 69 [upper]. See MASPERO, *Catalogue du Musée égyptien de Marseille* (1889), pp. 25-7 [40-3].

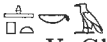

Yipu , Head of sandal-makers, and wife Takha^ct, Dyn. XIX, No. 235. Text, id. in *Rec. Trav.* xiii (1890), p. 121 [35]; WILBOUR MSS. iii. D. 11 [top]. Names and titles, LIEBLEIN, *Dict.* No. 2143. See MASPERO, *Catalogue du Musée égyptien de Marseille* (1889), p. 23 [35].

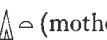
Munich, Staatliche Sammlung Ägyptischer Kunst.

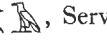
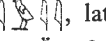

Ḥetepka , Director of vine-dressers, false-door fragment with brewing scenes, probably Dyn. V, Gl. 120. WOLTERS and VON BISSING in *Münchner Jahrb.* (1913), Abb. 4, pp. 159-60.

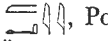

Detet  (mother Sit-ḥathor ) and her daughter Nefert , both King's sisters, Dyn. XII, Gl. 41. DYROFF and PÖRTNER, *Aegyptische Grabsteine und Denksteine aus süddeutschen Sammlungen*, ii, Taf. iv [5], pp. 10-11; VON BISSING, *Äg. Kunstgeschichte*, Taf. lix [370]. Some names, LIEBLEIN, *Dict.* No. 1212. See LAUTH, *Erklärendes Verzeichniss* [etc.] (1865), pp. 44-5 [28]; FURTWÄNGLER, *Beschreibung* [etc.] (1900), p. 40 [41]; WOLTERS, *Illus. Kat.* (1912), p. 14 [41]; id. *Führer* [etc.] (1928), p. 10 [41]; *Äg. Sammlung* (1966), No. 27; *Staatl. Sammlung* (1972), p. 50 [38b]; (1976), p. 74.

Nena , Servant (*sgm-rš*) in the Two Archives of the Good God, etc., and wife Iuy , late Dyn. XVIII, ÄS 51. DYROFF and PÖRTNER, op. cit. Taf. xiv [22], pp. 29-32; *Äg. Sammlung* (1966), Abb. 55; SEYFFARTH MSS. iii. 2947-53 [No. 5 verso]. Names and titles, LIEBLEIN, *Dict.* No. 630. See LAUTH, op. cit. pp. 21-2 [III, 1, 8]; *Staatl. Sammlung* (1972), p. 69; (1976), p. 102.



Ptahmay , Policeman, and wife Kaia , end of Dyn. XVIII, ÄS 48. DYROFF and PÖRTNER, op. cit. Taf. xviii [26], pp. 36-7; *Äg. Sammlung* (1966), Abb. 46; *Staatl. Sammlung* (1972), pl. 33, p. 64; (1976), p. 89 with Abb. (upper part of deceased and wife); SEYFFARTH MSS. iii. 2940-6 [left], 2940-6 verso [right]. Names and titles, LIEBLEIN, *Dict.* No. 913. See LAUTH, op. cit. p. 23 [III, 1, 14].



Paris, Louvre.



Wa^cten  and Neb(t)net  (women), niche-stela, Dyn. II-III, E.27157 (formerly in Saint-Ferriol Colln.). MORET in *Revue Égyptologique*, n.s. i (1919), pl. ii [right], pp. 1-5 [1]; *La Revue du Louvre*, xxvii (1977), fig. 1 on p. 253. Names, KAPLONY, *Inschriften*, i, pp. 233 [40], 513, 517-18. See SMITH, *Hist. Eg. Sculp.* p. 143 note 1.



Merib , Royal acquaintance, and son Nezemib , Steward, wooden niche-stela, end of Dyn. III or early Dyn. IV, N.3389. Names and titles, PIERRET, *Rec. inscr.* ii, p. 77 [lower]. See id. *Catalogue* (1882), No. 1; BOREUX, *Guide*, ii, pp. 484-5; VANDIER, *Guide* (1948), p. 35; (1952), p. 36; (1973), p. 69.



Kamosi , *šsbw*, and another man and a woman, with bark transporting funerary chest in register below, pyramidal stela, Dyn. XVIII, C 208. DEVÉRIA squeezes, 6166, ii. 131. Texts, PIERRET, *Rec. inscr.* ii, p. 64. See DE ROUGÉ, *Notice des monuments* (1883), pp. 155-6; BOREUX, op. cit. i, p. 90.

Ptaḥmay, Head of bearers of , and wife Iuy , Songstress of Bubastis, dedicated by son Yua , same title as father, Dyn. XVIII or later, C 210 [N.306]. ARCHIVES phot. E.104; DEVÉRIA squeezes, 6169, ii. 70-1. Texts, PIERRET, op. cit. ii, pp. 119-20. Names and titles, LIEBLEIN, *Dict.* No. 962, *Suppl.* p. 976. See DE ROUGÉ, op. cit. p. 157; BOREUX, op. cit. i, p. 89.

Pedamenōpet , son of Pakem , and (T)amen , before Western goddess, with demotic text of sale of tomb, year 8 of Psammetikhos I, C 101 [N.252]. MALININE in *Rev. d'Ég.* 27 (1975), pl. 13, pp. 168-73. Demotic text, REVILLOUT, *Mélanges sur la métrologie* [etc.], p. 417; id. *Contrats égyptiens* [etc.], pp. 80-4 [7]; transcription, id. in *Revue Égyptologique*, xii (1907), p. 207. Names and date, LIEBLEIN, *Dict.* No. 1137. See DE ROUGÉ, *Notice des monuments* (1883), pp. 117-18; REVILLOUT, *Cat.* No. 101; id. *Notice des papyrus démotiques archaïques* [etc.], pp. 276-7.

Eskhons , son of Uzakhons , and I'ohardais , Dyn. XXVI-XXVII, C 222 [N.314]. MUNRO, *Die spätägyptischen Totenstelen*, Taf. 58 [201], p. 383; DEVÉRIA squeezes, 6166, ii. 139; ARCHIVES phot. E.110. Names, LIEBLEIN, *Dict.* No. 1175, *Suppl.* p. 979. See DE ROUGÉ, op. cit. p. 165.

Neb'ankh , Royal scribe, Prophet of Osiris of Itefwēr , etc., son of Psammethēk and Tared , hieroglyphic and demotic texts, Ptolemaic, C 119 [N.270]. SPIEGELBERG in *Kémi*, ii (1929), pl. vi, pp. 107-12; ARCHIVES phot. E.622; DEVÉRIA squeezes, 6165, i. 70. Texts, BRUGSCH, *Die Inschrift von Rosette* [etc.], i, *Sammlung demotischer Urkunden* (1850), Taf. iv [H.7]; part, PIERRET, *Rec. inscr.* ii, p. 12. Names and titles, LIEBLEIN, *Dict.* No. 1196. See DE ROUGÉ, *Notice des monuments* (1883), pp. 122-3; MUNRO, op. cit. p. 341; QUAEGBEUR in *Chron. d'Ég.* xlix (1974), p. 70 [26]; WILDUNG, *Imhotep und Amenhotep*, pp. 53-4 [29].

Pa'ankhemthenen(t) , son of Hētepubaste , probably Late Period, C 226 [N.320]. DEVÉRIA squeezes, 6166, ii. 138. Text, PIERRET, op. cit. ii, p. 34; part, BRUGSCH, *Thes.* 1143 [bottom]. Names, LIEBLEIN, *Dict.* No. 1182. See DE ROUGÉ, op. cit. p. 166.

Philadelphia, Pennsylvania University Museum.

Irt-ptah , Scribe of the divine treasure in the Temple of Ptaḥ, etc., Dyn. VI, E 14318. *Penn. Mus. Bull.* 2 [2] (Dec. 1930), pl. ix, pp. 58-9; RANKE in ib. xv [2-3] (Nov. 1950), fig. 16, p. 30; FISCHER in *J.A.R.C.E.* iii (1964), pl. xv, pp. 25-9.

Princeton (New Jersey), University Art Museum.

'Ankh-ḥaṭḥor , Prophetess of Ḥaṭḥor Mistress of the Sycamore in all her places, and of Neith North of the Wall Opener of the Ways, temp. Userkaf or later, No. 42-48 (formerly in MacGregor and Hearst Collns.). *Sotheby Sale Cat.* (MACGREGOR), June 26-July 6, 1922,

pl. xlii (called 1667), pp. 203-4 [1572]; ib. (HEARST), July 11-12, 1939, pl. i [23], p. 7; *Record of the Museum of Historic Art, Princeton University*, i [2] (Fall 1942), pp. 10-11 with fig.

Sydney, Univ. Nicholson Mus. of Antiquities.

Pedēsi, son of Tadeusiri (mother), with hieroglyphic and Carian texts, Dyn. XXVI-XXVII, R.1141. ROWE in *The Journal of the Royal Asiatic Society* (1920), pp. 85-95 with pl.; TRENDALL, *Handbook to the Nicholson Museum* (1945), fig. 54, pp. 223-6; (1948), fig. 102, pp. 419-23; MASSON and YOYOTTE, *Objets pharaoniques à inscription carienne*, pl. iii, figs. 15, 16, pp. 28-31 [G] with bibliography of the Carian text; MASSON in *Bull. Soc. fr. d'Ég.* No. 56 (Nov. 1969), pl. iv, p. 34. See REEVE, *Catalogue of the Museum of Antiquities of the Sydney University* [etc.] (1870), pp. 90-1 [1141]; NICHOLSON, *Aegyptiaca*, pp. 140-1; MUNRO, *Die spätägyptischen Totenstelen*, p. 331, cf. Taf. 59 [197] (from MASSON).



Trento, Museo di Buon Consiglio.



Siamūn , Scribe of the great prison, Middle Kingdom. Text, VON BISSING in *Ä.Z.* xl (1902-3), pp. 118-19, cf. 120.

Turin, Museo Egizio.

Pedekhons and Imhōtep, both *wab*-priests of the Temples of Memphis, etc., sons of Khaṭṭap and Herankh, hieroglyphic and demotic texts, late Ptolemaic, Cat. 1578. BOTTI in *Archiv Orientální*, xx (1952), Tav. xxxiv, pp. 337-40; SEYFFARTH MSS. ix. 9160. Text, BRUGSCH, *Thes.* 1000-1 [9]. See ORCURTI, *Catalogo illustrato dei monumenti egizii del R. Museo di Torino* (1855), p. 117 [N.247]; FABRETTI, &c., *R. Mus. di Torino*, i, pp. 159-60; QUAEGBEUR in *Chron. d'Ég.* xlix (1974), p. 72 [30].

Uppsala, Victoriamuseum för Egyptiska Fornsaker.



Kakai-ḥa(?)ishtef  (?) , Noble of the King, fragment, temp. Neferirkarē or later, No. 23. LUGN, *Ausgewählte Denkmäler aus ägyptischen Sammlungen in Schweden*, Taf. x [14], pp. 13-14.





Nakht , Singer of Amūn, and wife May , Dyn. XVIII, No. 35. Id. ib. Taf. ix [11], pp. 10-12; Stockholm. 5000 år, No. 89 with fig. Text, KELLER in *Sphinx*, xxii (1931), pp. 58-66, cf. ANDERSSON-AKMAR in ib. pp. 40-1. Names and titles, LIEBLEIN, *Die ägyptischen Denkmäler* [etc.] (1873), Taf. xxvii [32], p. 76 [76]; id. *Dict.* No. 2059.



















Vatican, Mus. Gregoriano Egizio.



















































Ipiḥirsesenbef  Ipi, 1st Int. Period, Inv. 242. MARUCCHI in *Bessarione*, 1st Ser. ix (1901), fig. 3, pp. 6-10; id. *Catalogo del Museo Egizio Vaticano* (1902), pp. 354-60 [N.2] with fig.; id. in *Atti della Pontificia Accademia romana di Archeologia*, Ser. ii, *Dissertazioni*, viii (1903), fig. 3, pp. 9-13; id. *Guida del Museo Vaticano di scultura* (1924), pp. 283-4 [221] with fig. on p. 285; id. *Guide du Musée Égyptien du Vatican* (1927), fig. 7, pp. 34-6 [221]; BOTTI and ROMANELLI, *Le Sculture del Museo Gregoriano Egizio*, Tav. lviii [122], p. 75.

















Vienna, Kunsthistorisches Museum.

‘Anemḥo , Greatest of the directors of craftsmen, Prophet of Nektanebos II ‘the hawk’, Ptolemy III Euergetes I and Ptolemy IV Philopator, etc., son of Esisut , Greatest























of the directors of craftsmen, and Nefersobk     , hieroglyphic and demotic texts, year 5 of Ptolemy IV Philopator, Inv. 153. REINISCH, *Aegyptische Chrestomathie*, Taf. 18; WRESZINSKI, *Aegyptische Inschriften aus dem K.K. Hofmuseum in Wien*, Taf. iii, pp. 96-103; MUNRO, *Die spätägyptischen Totenstelen*, Taf. 61 [207], p. 342; SEYFFARTH MSS. xiv. 11337-8. Texts, BRUGSCH, *Thes.* 902-6 [2], cf. 856 [middle upper]; id. *Recueil*, pl. ix. Dates, WILKINSON MSS. v. 63 [upper]. Demotic, SPIEGELBERG in *Rec. Trav.* xxx (1908), pp. 147-8 [a]; LAUTH, *Die Schalttage* [etc.] in *Sitzungsberichte der königl. bayer. Akademie der Wissenschaften*, Philos.-philol. hist. Classe, iv [1] (1874), pl. at end [2], pp. 82-4. Names and titles, LIEBLEIN, *Dict.* No. 2509. Titles, see YOYOTTE in *Kémi*, xv (1959), p. 72 [2]; DE MEULENAERE in *Rivista degli Studi Orientali*, xxxiv (1959), p. 21; id. in *Chron. d'Ég.* xxxv (1960), p. 94 [5]. See *Uebersicht* (1895), p. 38 [153]; (1923), p. 13 [153]; QUAEGBEUR in *Chron. d'Ég.* xlix (1974), p. 73 [33].























Neferebrēc  , Secretary of the Temple of Ptaḥ in Ra-setau, etc., son of Neferebrēc, Secretary of the Temple of Osiris-Apis, etc., and Ḥer'ankh                 , hieroglyphic and demotic texts, probably temp. Ptolemy II Philadelphus, Inv. 130 (in 1st ed. as No. 157). WRESZINSKI, op. cit. Taf. ii [lower left], v [middle], pp. 93-6; SEYFFARTH MSS. xiv. 11335-6. Text, VON BERGMANN in *Rec. Trav.* vii (1886), p. 194 [top]; cf. SPIEGELBERG in *Rec. Trav.* xxx (1908), p. 149 [c] (as No. 156). Names and titles, BRUGSCH, *Thes.* 916 [6a]; LIEBLEIN, *Dict.* No. 2521. See DE MEULENAERE in *Chron. d'Ég.* xxxiv (1959), pp. 244-6; MUNRO, op. cit. pp. 342-3 [W.157]; QUAEGBEUR, op. cit. pp. 74-5 [36].



































Tadḥout                 , daughter of Tiamūn                 , (mother) and wife of Thaienḥorimu                 , Overseer of the granary, etc., hieroglyphic and demotic texts, Ptolemaic, 'Die Inschrift von Miramar', Inv. 5857. REINISCH, *Miramar*, Taf. xliii, p. 258 [36]; WRESZINSKI, op. cit. Taf. v, pp. 110-27 [172]. Hieroglyphic text, VON BERGMANN, *Hieroglyphische Inschriften* [etc.], Taf. viii-x. Demotic text, SPIEGELBERG in *Rec. Trav.* xxx (1908), figs. on p. 150, cf. p. 151 [e]; with parts of hieroglyphic text, LAUTH, *Alexander in Aegypten* in *Abhandlungen der königl. bayer. Akademie der Wissenschaften*, Philos.-philol. hist. Classe, xiv [1] (1876), pl. at end [1, 2, d, e], pp. 98-110, 150-64. See *Uebersicht* (1895), p. 39 [172]; (1923), p. 14 [172]; QUAEGBEUR in *Chron. d'Ég.* xlix (1974), p. 75 [37].

Zehō                 , son of 'Anemḥo, both Greatest of the directors of craftsmen, etc., and Ḥer'ankh, hieroglyphic and demotic texts, year 24 of Ptolemy III Euergetes I, Inv. 162. REINISCH, *Aegyptische Chrestomathie*, Taf. 19; WRESZINSKI, op. cit. Taf. iv, pp. 104-8; WILDUNG, *Imhotep und Amenhotep*, pp. 52-3 [28] with Taf. viii [right]. Demotic and part of hieroglyphic text, BRUGSCH, *Thes.* 912-15 [5]; SPIEGELBERG in *Rec. Trav.* xxx (1908), pp. 148-9 [b] with figs. Demotic, LAUTH, *Die Schalttage* [etc.] in *Sitzungsberichte der königl. bayer. Akademie der Wissenschaften*, Philos.-philol. hist. Classe, iv [1] (1874), pl. at end [1], pp. 77-82. Names and titles, LIEBLEIN, *Dict.* Nos. 1248, 2512. See MUNRO, op. cit. p. 342 [W.154]; QUAEGBEUR, op. cit. p. 73 [34].

Private collections, dealers, etc.

Neferti                       , Overseer of commissions of the Pyramid of Unis, etc., fragment, late Dyn. VI, in Sossidi Colln. HORNUNG in *Ä.Z.* 84 (1959), pp. 158-9 with fig.

Ptaḥemsaf                      , Steward, One who is in the magistracy, 1st Int. Period, in Wilborg Colln. Name and title, PETERSON in *Orientalia Suecana*, xix-xx (1970-1), p. 3 [iii]. See *Sotheby Sale Cat.* June 12, 1882, p. 6 [84]; June 26, 1952, p. 10 [91] (1st item).

Saka                       , . . . of the treasury of the Temple of Ra'sesse-meriamūn in the domain of Osiris, temp. Ramesses II or later, and Pakharu             and wife Amenemōpet

 probably Ramesside, both seen by Lepsius with Masarra (dealer). Names and titles, *L. D. Text*, i, p. 17 [middle].

Nezemt-mennüfer  (woman), fragment, New Kingdom, in private possession in Stockholm.

Others.

Iyka-nezes(?) , Recruiter of the desert guides of Wenet and of every foreign country (?), etc., niche-stela, Dyn. III–IV. FISCHER in *J.N.E.S.* xviii (1959), pl. xi, fig. 24, pp. 262–3 [c].

Sefget , Prophetess of Ḥaṭḥor, etc., Dyn. VI. Id. in *Metropolitan Museum Journal*, 11 (1976), fig. 12, pp. 21–2.

Sitnetpepy , Prophetess of Ḥaṭḥor, fragment, probably Dyn. VI. Name and title, id. *Varia*, p. 69 note 3.

Amenḥori . . . , dedicated by brother Minmosi, probably Dyn. XVIII. Text, PETRIE in SAYCE MSS. 25b.

Woman before Osiris, text illegible, Dyn. XIX. MURRAY, *Saqqara Mastabas*, i, pl. xxxvi [1], p. 28 [62].

Ḍḥutmosi, Head of the store-room, and wife Thuiay , before Osiris and Isis, New Kingdom. WILKINSON MSS. xx.A.10 [left upper].

Hager , son of Zeamünefankh and Irtarau, Late Period. CAIRO, CENTRE OF DOCUMENTATION photo, S.A., 2404.

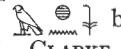
Ḥarkhons , before Rē-Ḥarakhti and Osiris, and four relatives and text below, Late Period. CLARKE (E. D.), *Travels in Various Countries of Europe, Asia and Africa*, ii [2] (1814), pl. facing p. 172.

Nefer(t)iyt , daughter of Ḥaremakhēt, Greatest of the directors of craftsmen, etc., and Nefer(t)iyt, Ptolemaic. Text, DARESSY in *Rec. Trav.* xiv (1893), p. 184 [lxxxii]. See QUAEGBEUR in *Chron. d'Ég.* xlix (1974), p. 75 [38].

Blocks, etc.

Amsterdam, Allard Pierson Museum.

Two, (a) bullock and legs of man, (b) upper part of man with basket on head, Ptolemaic, formerly in von Bissing Colln., Nos. 7790–1. VON BISSING, *Denkmäler*, ii, Taf. 102 [a, b].

Antwerp, Museum Vleeshuis.

Lintel with double scene, deceased (no name) kneeling before divinities, Dyn. XXVI (De Wit) or Ramesside, No. 79.1.152. *Oudheidkundige Musea. Vleeshuis, Cat. viii, Egypte*, pl. x [12], p. 26. See ALLEMANT, *Collection d'antiquités égyptiennes* [1878], No. 207; *A Catalogue . . . Collection of Egyptian Antiquities . . . Allmant*, Foster Sale Cat., London, May 9–10, 1878, No. 251; *Cat. de la Collection d'antiquités égyptiennes* (1881), pp. 28–9 [152].

Baltimore, Walters Art Gallery.

Three female dancers, Dyn. V–VI, No. 22.83 (formerly in Mosenthal Colln.). *Sale Cat. New York, American Art Galleries*, April 4, 1925 (MOSENTHAL), No. 103 with fig. on p. 57; SHOOLMAN and SLATKIN, *The Enjoyment of Art in America*, pl. 8; STEINDORFF, *Cat. pl. xliii* [264], p. 78; *Handbook of the Collection* (1944), fig. on p. 15.

Fragment with name of Psammethék-emakhet, Dyn. XXVI, No. 22.286. STEINDORFF, *Cat. pl. xlvii* [289], p. 87.

Berlin (East), Ägyptisches Museum.

Block with Pyramid-texts of Niʿankh-meryrē , probably Dyn. VI, No. 7730. Text, *Aeg. Inschr. i*, p. 3. See *Ausf. Verz.* p. 44; SETHE, *Pyramidentexte*, i, p. viii note 1.

Fowl-yard, Dyn. V, No. 14642. WRESZ., *Atlas*, i, 27, and iii. 83 [C]; Muzeul de artă, Bucharest. *Egiptul antic* [etc.] (1975), No. 94 with fig. on p. 48. Men feeding fowl, FECHHEIMER, *Plastik* (1914), Taf. 126; (1923), Taf. 136; KLEBS, *Reliefs . . . a. R. Abb.* 53; SCHÄFER, *Äg. Kunst*, fig. on p. 15 [2]; HAMANN, *Äg. Kunst*, Abb. 18; id. *Tierplastik im Wandel der Zeiten*, Taf. 9; LANGE, *Lebensbilder*, Abb. 5; *Sculptures et textes*, fig. on p. 70; BOESSNECK, *Die Haustiere in Altägypten*, Taf. 18 [37], p. 34; PIRENNE, *Hist. civ.* i, pl. 80 [lower] facing p. 257; BRUNNER-TRAUT, *Die Alten Ägypter*, Taf. 13. Man feeding crane, SCHÜZ, *Über Stelzvögel* [etc.] in *Die Vogelwarte*, 23 (1966), Abb. 8 on p. 270; id. *Vögel der Pharaonen in Vogel-Kosmos*, Heft 11 (Nov. 1967), fig. on p. 371. Gooseherd with fowl, Szépművészeti Múzeum, Budapest. *Egyptomi művészet* [etc.] (1975), No. 184 with fig. 4. Two geese, KUENTZ, *L'oe du Nil*, figs. 3, 4, p. 6 [1, 2]. Lotus-column capital, KÖSTER in *Rec. Trav.* xxv (1903), fig. 2, p. 98. Names of fowl, *Aeg. Inschr. i*, p. 24. See *Führer* (1961), p. 46.

Vintage scenes, Dyn. V, No. 15071. Pressing grapes, KLEBS, *Reliefs . . . a. R. Abb.* 44a. Remains of time-beaters, SACHS, *Die Musikinstrumente des alten Ägyptens*, Abb. 2 on p. 12. Texts, *Aeg. Inschr. i*, p. 23.

Two men with offerings, and upper part of deceased (no name), temp. Ramesses II, No. 12410. ERMAN in *Ä.Z.* xxxiii (1895), Taf. ii [b], pp. 21–3; *Budapest. Ägyptische Kunst. Sonderausstellung . . . Museen zu Berlin . . . 1963*, No. 60 with Abb. xi; *Prague, Náprstkovo muzeum. Katalog výstavy Egypt . . . 1964*, No. 59 with fig.; WENIG in *Forschungen und Berichte. Staatliche Museen zu Berlin*, 14 (1972), Taf. 2 [3], pp. 43–4 [4]; *Gudar och människor vid Nilen* (Göteborg, 18 mars–20 maj 1973), No. 325 with pl. 21; Kunstmuseet i Ateneum Helsingfors. *Det eviga Egypten. Aegyptus aeterna* (1973), No. 186 with fig. 15 and front cover. Upper part of deceased, ERMAN, *Die ägyptische Religion* (1905), fig. 54; (1909), fig. 60; id. *Die Religion der Ägypter*, fig. 80 on p. 190; head, ANTHES, *Aeg. Plastik*, Taf. 44; id. *Meisterwerke*, Taf. xxxvi; SAUNERON, *Les prêtres de l'ancienne Égypte*, fig. on p. 40; BRUNNER-TRAUT, *Die Alten Ägypter*, Taf. 60. Text, *Aeg. Inschr. ii*, pp. 178–9. See *Ausf. Verz.* pp. 150–1.

Three registers, **I**, transport of statue in boat across canal, **II**, priests and kiosks with offerings, **III**, shrine with coffin dragged in procession, Ramesside, No. 12412. Text, *Aeg. Inschr. ii*, p. 178; LÜDDECKENS in *Mitt. Kairo*, 11 (1943), pp. 146–7 [72]. See *Ausf. Verz.* p. 153; *Führer* (1961), p. 65.

Funerary procession leaving temple, end of Dyn. XVIII or Ramesside, No. 13297. *Aeg. und Vorderasiat. Alterthümer*, Taf. 111; VON BISSING, *Einführung in die Geschichte der Ägyptischen Kunst* [etc.], Taf. xvi. Doorkeeper and men with flowers, WRESZ., *Atlas*, i, 91 c [11]. See *Ausf. Verz.* p. 152.



Five seated Kings (name of the 1st lost), Raʿzedef, Menka(u)rē, Ikau[hor] (Menkauhor), Neferkarē (Pepy II), Ramesside, No. 1116. *L. D.* ii. 152 [d] (name of the 2nd as Zadkarē), *Text*, i, p. 138; WILDUNG, *Die Rolle äg. Könige*, i, Abb. xvii [1], pp. 197–8 [Dok. xxii. 90], 222 [Dok. xxiv. 80]; cartouches, *Aeg. Inschr. ii*, p. 201; GAUTHIER, *Livre des Rois*, i, pp. 100 [xxiv], 123 [iii], 136 [xvii], 174 [xxiv] (reading the 2nd Zadkarē); see *Ausf. Verz.* p. 156.

Metal-workers, leather-workers, chariot-makers, carpenters and sculptors, Ramesside, No. 19782. WRESZ., *Atlas*, i. 384.

Three registers of funeral procession, including coffin dragged and carried and men with funerary equipment, Dyn. XIX, No. 24042. F.E.R.E. photo. 21515.

Four registers of ancestors, 'Genealogy of a Memphite Priest', Dyn. XXII, No. 23673. BORCHARDT, *Die Mittel zur zeitlichen Festlegung von Punkten der ägyptischen Geschichte und ihre Anwendung*, Bl. 2, 2a, pp. 96-112. Name of Amenemnesut, see GRDSELOFF in *Ann. Serv.* xlvii (1947), pp. 209-11. See *Führer* (1961), p. 74.

Unidentified in East Berlin or lost.

Block with Pyramid-texts of 'Ankh(n)espepy  ♀  |, probably woman and Dyn. VI, No. 7495 (stolen). Text, *Aeg. Inschr.* i, p. 3. See SETHE, *Pyramidentexte*, i, p. viii note 1.

Two offering-bringers, Dyn. VI, No. 7768. Text, *Aeg. Inschr.* i, p. 26. See *Ausf. Verz.* p. 58.

Head of man, Dyn. V, No. 23798. WRESZ., *Atlas*, iii. Textabb. 19.9 on p. 35; SCHÄFER in *Ä.Z.* 74 (1938), Abb. 3, 4 [f], pp. 27-8.

Man at table, with daughter and monkey under chair, late Dyn. XVIII or Dyn. XIX, No. 8816. *Aeg. und Vorderasiat. Alterthümer*, Taf. 109; WRESZ., *Atlas*, i. 389; SCHÄFER, *Von äg. Kunst* (1919), Taf. 34; (1922 and 1930), Taf. 32; (1963), Taf. 31; Eng. ed. *Principles of Egyptian Art*, pl. 51. Text, *Aeg. Inschr.* ii, p. 205. See *Ausf. Verz.* p. 150.

Two registers of funeral procession, late Dyn. XVIII or Dyn. XIX, No. 14945. PIJOÁN, *Summa Artis*, iii (1945), fig. 596. See WERBROUCK, *Pleureuses*, p. 76.

Berlin (West), Ägyptisches Museum.

Two, attendants and men bringing animals, and offering-bringers, late Dyn. V, Nos. 4-8/63. KAISER, *Äg. Mus. Berlin* (1967), pp. 27-8 [235-6] with Abb.

Bologna, Museo Civico.

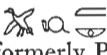
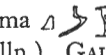
Pillar of Paraemhab  and Kema  |, both Overseers of the cabinet, Dyn. XIX, No. 1892 (formerly Palagi Colln.). GAUTHIER in *Ann. Serv.* xxxv (1935), pl. ii, pp. 87-90; GARDINER MSS. photo. 28.417-34. Two faces, PETRIE ITAL. photos. 240-2; one, Paraemhab carrying *zad*-pillar, CURTO, *L'Egitto antico* (1961), Tav. 33 [56], p. 85. Some texts, KMINEK-SZEDLO, *Catalogo di antichità Egizie*, pp. 173-5; PIEHL in *Rec. Trav.* i (1870), pp. 204-5 [12]. See DUCATI, *Guida*, p. 51 [B]; *Pelagio Palagi, artista e collezionista* (Bologna, Museo Civico, April-June 1976), No. 486.

Panel from pilaster of Ptahemwia  |, Royal butler clean of hands, with hymn to Rē, Dyn. XIX, No. 1891. KMINEK-SZEDLO, *Saggio filologico per l'apprendimento della lingua e scrittura egiziana* [etc.] (1877), Tav. x [2], pp. 80-1; CURTO, op. cit. Tav. 33 [55], pp. 84-5; PETRIE ITAL. photos. 238-9. Deceased, GARDINER MSS. photo. 28.436. See KMINEK-SZEDLO, *Catalogo di Antichità Egizie*, pp. 171-3 (text); DUCATI, op. cit. p. 51 [A].

Boston, Museum of Fine Arts.

Fragment of side-piece of Khet[y]  |, Royal acquaintance, with butchers and offering-bringers, 1st Int. Period, No. 24.594. WRESZ., *Atlas*, iii. 94 [C]; SIMPSON in *North Carolina Museum of Art. Bulletin*, xi [3] (Dec. 1972), fig. 13, p. 9; id. *The Face of Egypt: Permanence and Change in Egyptian Art*, No. 5 with fig. Lower register, SMITH, *Country Life*, fig. 28. See id. *Anc. Eg.* (1960), pp. 63-4.

Two registers, I, legs of two men and offerings, II, head of Maḥuy , Scribe of the Temple of Ptah, probably temp. Amenophis III, No. 1975.702. SIMPSON, *The Face of Egypt: Permanence and Change in Egyptian Art*, No. 39 with fig. (as No. 1975.202); *100th Annual Report 1975-6*, fig. on p. 19 [bottom], cf. p. 22.

Brooklyn Museum.

Servant preparing bed under canopy, early Dyn. VI, No. 71.10.1. FAZZINI in *Miscellanea Wilbouriana*, 1 (1972), fig. 7, p. 41. See *The Brooklyn Museum Annual*, xii (1970-1), p. 21.

Two offering-bringers, late Dyn. XVIII or Dyn. XIX, No. 37.1505E (formerly N.Y. Hist. Soc. Colln.). See *N.Y.H.S. Cat.* p. 24 [377].

Upper part of old man, late Dyn. XVIII, No. 47.120.1. RIEFSTAHL in *J.N.E.S.* x (1951), pls. i, ii, pp. 65-72; ALDRED, *N.K. Art* (1951), pl. 106; (1961), pl. 111; *Eg. Art . . . Brooklyn*, fig. 42; SMITH, *Art . . . Anc. Eg.* pl. 145 [B], p. 209; FAZZINI, *Images for Eternity*, Cat. No. 70; BRUNNER-TRAUT in *Festschrift Ägyptisches Museum Berlin* (1974), Taf. 5 [a], p. 77; *Égypte Éternelle. Chefs-d'œuvre du Brooklyn Museum* (Palais des Beaux-Arts, Bruxelles, 9 décembre 1976-20 février 1977), No. 52; *Ägyptische Kunst aus dem Brooklyn Museum* (Berlin, Ägyptisches Museum, 4. Sept.-31. Okt. 1976), No. 52.

Upper part of man, Dyn. XIX, No. 36.261 (formerly in The Hague, Scheurleer Mus.). Ib. No. 58; SCHÄFER and ANDRAE, *Kunst* (1930 and 1942), 396 [2]; RIEFSTAHL, *People of the Black Land, Egypt*, Ser. i, No. 3, 2nd fig.; *Handbook* (1967), pl. on p. 72; *Brief Guide* (1970) and (1974), pl. on p. 54; *Égypte Éternelle. Chefs-d'œuvre du Brooklyn Museum* (Palais des Beaux-Arts, Bruxelles, 9 décembre 1976-20 février 1977), No. 58 and fig. on p. 64; FAZZINI, op. cit. Cat. No. 80; F.E.R.E. photo. 17415.

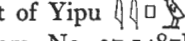
Text of Yipu , Overseer of the Treasury, etc., and two genii with knives, New Kingdom, No. 37.1487E (formerly N.Y. Hist. Soc. Colln.). SHARPE, *Eg. Inscr.* 2 Ser. 41 [middle]; omitting text on right, LIEDER squeezes, 13. See *N.Y.H.S. Cat.* p. 25 [384].

Two blocks with female mourners, New Kingdom, Nos. 37.31E, 37.1504E (formerly N.Y. Hist. Soc. Colln.). WERBROUCK, *Pleureuses*, pl. xxxviii (No. 37.1504E), p. 91. See *N.Y.H.S. Cat.* p. 8 [124, 118].

Upper part of Shepenius'aset , sem-priest, etc., Dyn. XXVI, No. 61.165. FAZZINI in *Miscellanea Wilbouriana*, 1 (1972), fig. 31, pp. 61-3. Head, *Art of Ancient Egypt* (Emily Lowe Gallery, Hofstra University, Hempstead, New York, Feb. 22-April 6, 1971), No. 20 with fig. See COONEY in *The Brooklyn Museum Annual*, ii-iii (1960-2), pp. 72, 109.

Text of Weḥebrē, Late Period, No. 37.1513E (formerly N.Y. Hist. Soc. Colln.). See *N.Y.H.S. Cat.* p. 12 [158].

Brussels, Mus. Roy. d'Art et d'Hist.

Three negroes, end of Dyn. XVIII, E.7559. CAPART in *Chron. d'Ég.* xxxii (1957), fig. 18, p. 171 (repr. *Causeries sur l'Art égyptien*, fig. 8, p. 14).

Three blocks with funeral procession of Neferronpet , Royal scribe, Dyn. XIX, E. 3053-5. CAPART in *Bull. Mus. Roy.* 2 Sér. i (1908), fig. 8, pp. 76-8 [35-7]; id. *Donation d'antiquités égyptiennes* (1911), fig. 8, pp. 24-7; WERBROUCK, *Pleureuses*, pl. xxxii, p. 79. E.3053, *Bruxelles. Mus. Roy. Département égyptien. Album* (1934), pl. 37. Text, SPELEERS, *Rec. inscr.* pp. 39-40 [149].

Part of Chapter 182 of Book of the Dead, Dyn. XIX, E.3056. Text, id. ib. p. 61 [254]; id. in *Rec. Trav.* xl (1923), p. 86.

Cairo Museum.

Old Kingdom.

Block of 'Ankh-kakai  King's *warb*-priest, probably Dyn. V, JE 43972.

ENGELBACH in *Ann. Serv.* xxxiv (1934), pp. 157-8 with fig.; CAIRO, CENTRE OF DOCUMENTATION photo. S.A., 2195.

Block of Isesikha[ef]  Overseer of commissions of the Pyramid of Pepy I, etc., temp. Pepy I or later, CG 1438. MARIETTE, *Mastabas*, p. 456 [H 10]. Text, BORCHARDT, *Denkmäler*, i, p. 120.

Drum of Ptaḥshepses, Prophet of Ptaḥ, etc., Dyn. V-VI, CG 1701. Text, id. ib. ii, p. 143.

Lintel of Sekhemrēc  Old Kingdom, JE 17803.

Lintel with offering-text, probably Dyn. VI, CG 1434. Id. ib. Bl. 28, pp. 114-15; MARIETTE, *Mastabas*, fig. on p. 433 [F 2]; DE ROUGÉ, *Inscr. hiéro.* pl. xxxviii. Part of lines 4 and 5, BRUGSCH, *Thes.* 401.

Remains of titles connected with Pyramids of Merenrēc I and Pepy I, temp. Merenrēc I or later, CG 1437. Text, BORCHARDT, op. cit. i, p. 120.

Tending goats and cattle, probably Dyn. V, CG 1531. Id. ib. Bl. 47, pp. 229-30; PERROT and CHIPIEZ, *Hist. de l'Art*, i, fig. 29 [lower]. Text, ČERNÝ Notebook, 118, p. 83.

Boatmen jousting, with remains of fishing and cutting open fish above, Dyn. V, CG 1535. BORCHARDT, op. cit. i, Bl. 49, pp. 236-7; CAPART, *Memphis*, fig. 389; MASPERO, *Égypte*, fig. 117; KEES, *Ägypten* (OTTO, *Handbuch der Altertumswissenschaft*, iii, Pt. 1, vol. iii, *Kulturgeschichte des Alten Orients*, 1), Taf. 18; ENGELBACH, *Introduction*, pl. ix [2]; RIESTERER, *Kunstschätze . . . Kairo*, pl. 7; FORMAN (W. and B.) and VILÍMKOVÁ, *Eg. Art*, pl. 32; *Great Museums*, pl. 31, fig. on p. 50; TERRACE and FISCHER, *Treasures*, pp. 61-4 with pls.; PERC, *Spomeniki starega Egipta* (1974), No. 13 with fig. Details, DONADONI, *Egyptian Museum Cairo*, pl. on p. 61; MICHALOWSKI, *Art*, fig. 262; QUIBELL (A. A.), *Egyptian History and Art*, pl. vi; SMITH, *Hist. Eg. Sculp.* fig. 129, p. 285. Fishing with baskets, LACAU in *B.I.F.A.O.* liv (1954), pl. i, fig. 1, pp. 137-43. See MASPERO, *Guide*, p. 88 [236].

Offering-bringers and bakers with loaves of bread, Dyn. V, Cairo Mus. CG 1544. BORCHARDT, *Denkmäler*, ii, Bl. 54, pp. 3-4; WRESZ., *Atlas*, i. 399; GRIFFITH INST. photo. 351. Text, ČERNÝ Notebook, 118, p. 88. See MASPERO, *Guide*, pp. 86 [232, A].

Heaping straw and winnowing corn, Dyn. V-VI, CG 1546. BORCHARDT, op. cit. ii, Bl. 55, pp. 5-6; WRESZ., op. cit. iii. 56 [B], and i. 382 [bottom]. Incomplete, PERROT and CHIPIEZ, *Hist. de l'Art*, i, fig. 28. Women winnowing, WENIG, *Die Frau*, pl. 17 [upper]. Text, ČERNÝ Notebook, 118, pp. 88-9. See MASPERO, *Guide*, p. 88 [237].

Boatmen jousting, Dyn. V, CG 1547. BORCHARDT, op. cit. ii, Bl. 55, pp. 6-7.

Bringing cattle, Dyn. V, CG 1560. Id. ib. Bl. 62, pp. 22-3; WRESZ., op. cit. iii. 86 [A]. Man with cow, *Encycl. phot. Caire*, pl. 39. Text, ČERNÝ Notebook, 118, p. 94. See MASPERO, *Guide*, p. 86 [232, D].

Brewing and baking, probably Dyn. V, CG 1561. BORCHARDT, op. cit. ii, Bl. 63, pp. 23-4; id. in *Ä.Z.* xxxv (1897), fig. on p. 129 [bottom]; WRESZ., op. cit. i. 398; GRIFFITH INST. photo. 352. Female brewer in vat, SCHARFF, *Die Altertümer der Vor- und Frühzeit Ägyptens*, ii, Abb. 24. See MASPERO, *Guide*, pp. 86-7 [232, B].

Herdsmen tending cattle, mat-making, and cooking, and men cutting open fish, Dyn. V, CG 1562. BORCHARDT, *Denkmäler*, ii, Bl. 63, pp. 24-5. Left part, WRESZ., *Atlas*, i. 397; omitting top register, PERROT and CHIPIEZ, *Hist. de l'Art*, i, fig. 27; BORCHARDT in *Ä.Z.* 44 (1907), Abb. 3 on p. 78. Right part, omitting top register, DUNHAM in *J.A.O.S.* 56 (1936), fig. 1, p. 174 (Boston Mus. squeeze 78.152).

Man in canoe with lotus-flowers and cage of birds, Dyn. V-VI, in Cairo Mus. JE 40027. KEIMER in *R.E.A.* ii (1929), fig. 46, p. 238.

Offering-list and priests, Old Kingdom, CG 1630. Text, BORCHARDT, *Denkmäler*, ii, p. 99.

Remains of netting fish and fowl, with overseer, unfinished, Old Kingdom, CG 1720. Id. ib. Bl. 92, p. 154.

Industries, an Overseer of smelters of gold of King's adorners, and offering-list, Old Kingdom, CG 57130 (JE 38070).

Man with staff and sceptre, Old Kingdom, CG 57182 (JE 36585). KIELLAND, *Geometry in Egyptian Art*, fig. 55.

Milking scene, Old Kingdom, JE 89660.

Lintel with cryptographic offering-text, Old Kingdom, CG 1696. BORCHARDT, *Denkmäler*, ii, Bl. 89, p. 140; text, DRIOTON in *Mélanges Maspero*, i [2], pp. 697-704; hieroglyph of man holding bull, L. D. Text, i, on p. 139; CAPART in *Kémi*, ii (1929), pl. i [1], pp. 1-2.

New Kingdom.

Ptahnüfer $\text{𓆎} \text{𓆏}$, Scribe of the Treasury, Dyn. XIX. Mourners before mummy held up by Anubis, Temp. No. 10.6.24.12; WERBROUCK, *Pleureuses*, pl. xxii, p. 82; MORET, *Au temps des Pharaons*, pl. xv; id. *In the Time of the Pharaohs*, pl. xv; see MASPERO, *Guide*, p. 164 [561]. Man censuring and libating to deceased at table, Temp. No. 12.6.24.6; MASPERO, *Égypte*, fig. 370; MARBURG INST. photo. 86562.

Female dancers with tambourines, and men with upraised arms,¹ Dyn. XIX, JE 4872. DE ROUGÉ, *Album photo.* pl. 135; PERROT and CHIPIEZ, *Hist. de l'Art*, i, fig. 472; WEIGALL, *Anc. Eg. . . . Art*, 240 [lower]; MASPERO, *Égypte*, fig. 371; FECHHEIMER, *Plastik* (1914), Taf. 147; (1923), Taf. 159; WRESZ., *Atlas*, i. 419; LEIBOVITCH, *Anc. Eg.* fig. 87; GALASSI, *Tehenu*, fig. 115; id. in *Critica d'Arte*, n.s. ii (1955), fig. 285, p. 354; RANKE, *The Art of Ancient Egypt*, and BREASTED, *Geschichte Aegyptens* (1936), 238-9; HICKMANN, *45 Siècles*, pl. lxiii [A]; id. *Ägypten*, Abb. 32; id. in *Ann. Serv.* xlix (1949), fig. 51, p. 531; MITRY, *Illus. Cat.* No. 562; WOLF in *Archiv für Orientforschung*, vi (1930-1), Taf. xi [3], pp. 264-5; FORMAN (W. and B.) and VILÍMKOVÁ, *Eg. Art*, pl. 93; *Encycl. phot. Caire*, pl. 150; STIERLIN VALLON, *Que savons-nous de la musique pharaonique?* in *Formes et Couleurs*, xi [1] (1949), 1st fig.; PRITCHARD, *Anc. Near East*, fig. 211; WENIG, *Die Frau*, pls. 72-3; TERRACE and FISCHER, *Treasures*, pp. 145-8 with pl.; DONADONI, *Egyptian Museum Cairo*, pl. on p. 139, cf. pp. 139-40; MICHAŁOWSKI, *Piramidy i mastaby*, pl. 77; *Ramsès le Grand* (Galeries Nationales du Grand Palais, Paris, 1976), Cat. xxv; VANDERSLEYEN, *Das Alte Ägypten*, Abb. 306; DESROCHES-NOBLECOURT in *La Revue du Louvre*, xxvi (1976), fig. 5 on p. 113; DEVÉRIA squeezes, 6170A, 13, 13bis, 18. Dancers, SAMEH, *Daily Life*, fig. on p. 131; DE RACHEWILTZ, *L'Arte*, Tav. 53, p. 62; PIRENNE, *Hist. civ.* ii, pl. 89 facing p. 381; MENDELSSOHN, *The Riddle of the Pyramids*, pl. 2; and two men, PRISSE, *L'Art ég.* ii, *Sculpture*, 45th pl. [lower] 'Fragments de bas-reliefs funéraires', *Texte*, p. 418; BORCHARDT, *Works of Art*, pl. 28; MASPERO and ROEDER, *Führer*, Taf. 33, p. 47 [375]; RAGAI, *L'Art*, pl. 10 [25]; HICKMANN in *Cahiers d'Hist. Ég. Sér.* v [2, 3] (June 1953), fig. 5, pp. 170-2; id. in *Egypt Trav. Mag.* No. 30 (Feb. 1957),

¹ Selected references.

fig. 2 on p. 7; DONADONI, *Arte Egizia*, fig. 160; MICHALOWSKI, *Art*, fig. 520. See MASPERO, *Guide*, pp. 164–5 [562].

Hathor-pillar fragment of Neferhōtep $\dagger \frac{\text{𓆎}}{\text{𓆏}}$, Scribe of silver and gold of Ptaḥ, etc., Dyn. XIX, JE 18928. PERROT and CHIPIEZ, *Hist. de l'Art*, i, fig. 343; GRIFFITH INST. photo. 364; VASSALLI MSS. 9 [left]. Names and titles, LIEBLEIN, *Dict.* No. 2120. See MASPERO, *Guide*, p. 183 [676].

Three registers of Neferhōtep, Count, I (lower part only), men, tied oxen, etc., II, funeral procession in two boats, III (upper part only), two scenes of purification of mummy, supervised by a Governor of the town and by a Vizier, late Dyn. XVIII or Ramesside, Temp. No. 8.II.26.4. CAIRO, CENTRE OF DOCUMENTATION photo. S.R., Box 122, 9323.

Funeral procession, with female dancers, late Dyn. XVIII or Ramesside, JE 43278.

Jamb of Ptaḥemwia, Royal butler clean of hands, etc., Ramesside, JE 8383 (formerly Huber Colln.). Text, BRUGSCH, *Recueil*, pl. vii [1]. Name and titles, DE ROUGÉ, *Inscr. hiéro.* pl. lviii [bottom]; LIEBLEIN, *Dict.* No. 2018 (last two as stela). See MASPERO, *Guide*, p. 126 [416A].

Pillar of Amenhotp and Pendua $\square \star \frac{\text{𓆎}}{\text{𓆏}}$, Scribe, New Kingdom, Temp. No. 20.1.25.5. BRUYÈRE, *Rapport sur les fouilles de Deir el Médineh (1924–1925)*, fig. 14, p. 24; (1935–1940), fasc. iii, fig. 11, p. 117.

Man making libation, late Dyn. XVIII or Ramesside, Temp. No. 25.6.24.8. See MASPERO, *Guide*, p. 180 [652, A].

A Royal scribe, Steward (name lost), seated, and three registers of cleaning and bringing fowl and fish, probably late Dyn. XVIII, Temp. No. 25.6.24.6. WRESZ., *Atlas*, i. 84a; VON BISSING, *Die Kultur des alten Ägyptens*, Taf. 4 [7]; GRIFFITH INST. photo. 361. Sketch, WILBOUR MSS. 2 D, 36. See MASPERO, *Guide*, p. 180 [652, C].

Man (name lost) before Osiris seated, late Dyn. XVIII or Dyn. XIX, JE 44927.

Two registers, I, women mourners with a girl, and man leading ox, II, men bringing furniture and canopic-jars, Ramesside, Temp. No. 1.7.24.5.

Two registers, I, woman seated by chair with [husband seated], II, four offering-bringers, late Dyn. XVIII or Dyn. XIX, Temp. No. 27.6.24.2.

Chicago, Art Institute.

Offering-bringers, temp. Teti or later, No. 10.228. ALLEN, *A Handbook of the Egyptian Collection (1923)*, p. 29 with fig.

Chicago, Field Museum of Natural History.

Text, and below, [deceased at] table, with two registers of men performing purification and Opening-the-Mouth ceremonies, and farther to the right, lower part of man kneeling, with three columns of offering-texts below, late Dyn. XVIII, A. 31291–2.

Cincinnati (Ohio), Art Museum.

Ploughing, and flax-harvest, Dyn. V, No. 1971.28. *Bulletin*, 9 [3] (June 1972), fig. on p. 13, cf. p. 11; *Gazette des Beaux-Arts*, lxxix (1972), Supp. Feb. 1972, fig. on p. 66 [228]; *Cincinnati Art Museum Handbook (1975)*, fig. on p. 9 [left]. See *The Art Quarterly*, xxxiv (1971), p. 371.

Copenhagen, Nationalmuseet.

Block with Senezemib , Supervisor of prophets of the Pyramid of Pepy I, etc., temp. Pepy I or later, No. 15002. BUHL in *Mélanges de l'Université Saint-Joseph*, xlv (1969), pl. i [left], pp. 197-201; id. in *Nationalmuseets Arbejdsmark* (1969), fig. 1, pp. 163-8; id. *A Hundred Masterpieces from The Ancient Near East*, No. 50 (text incomplete).

Copenhagen, Ny Carlsberg Glyptothek.

Lintel of Mimeth , Royal acquaintance, Dyn. V-VI, Æ.I.N. 1448. KOEFOED-PETERSEN, *Cat. des bas-reliefs*, pl. xxviii [25], pp. 28, cf. 72. Text, id. *Rec. inscr.* p. 32 [1448].

Lintel of Neferherentpah , Prophet of Khufu, etc., Dyn. V-VI, Æ.I.N. 1446. Id. *Cat. des bas-reliefs*, pl. xxvii [24], pp. 27-8 (as Æ.I.N. 1447), cf. 72. Text, id. *Rec. inscr.* p. 32 [1446].

Jamb of Sekhentka , Royal chamberlain, etc., Dyn. IV-V, Æ.I.N. 690. MOGENSEN, *Coll. ég.* pl. xci [A 657], p. 88; SCHMIDT, *Choix* (1910), pl. ii [1], p. 12; id. *Levende og Døde*, fig. 116; CAPART, *L'Art ég.* (1911), pl. 121; KOEFOED-PETERSEN, *Cat. des bas-reliefs*, pl. xix [20], pp. 25-6, 72; *Capolavori*, i, No. 10 (1963), fig. on p. 155 [left]; Eng. ed. fig. on p. 147 [left]. Text, SCHMIDT, *Den Æg. Sam.* (1908), pl. 8 [5], pp. 52-3 [E.9]; KOEFOED-PETERSEN, *Rec. inscr.* p. 31 [690].

Two offering-bringers, Dyn. V-VI, Æ.I.N. 16. MOGENSEN, *Coll. ég.* pl. xcii [A 665], p. 89; KOEFOED-PETERSEN, *Cat. des bas-reliefs*, pl. xxv [10], pp. 19, cf. 69. Text, id. *Rec. inscr.* p. 77 [16]. See SCHMIDT, *Den Æg. Sam.* (1908), p. 67 [E.27].

Lintel-fragment with offering-text, Dyn. V-VI, Æ.I.N. 17. MOGENSEN, *Coll. ég.* pl. xciii [A 669], p. 89; KOEFOED-PETERSEN, *Cat. des bas-reliefs*, pl. xxviii [27], p. 29. Text, SCHMIDT, *Den Æg. Sam.* (1908), pl. 5 [3], p. 67 [E.28].

Bringing animals and fowl, Dyn. V-VI, Æ.I.N. 938. MOGENSEN, *Coll. ég.* pl. xcii [A 664], p. 89; KOEFOED-PETERSEN, *Cat. des bas-reliefs*, pl. xv [7], pp. 17-18; SCHMIDT, *Choix* (1910), pl. iii [4], pp. 13-14. See id. *Den Æg. Sam.* (1908), pp. 58-60 [E.14].

Two blocks, (a) piling up sheaves, (b) filling granaries and rendering accounts, Dyn. V-VI, Æ.I.N. 939-40. MOGENSEN, *Coll. ég.* pl. xcii [A 663, 662], p. 89; KOEFOED-PETERSEN, *Cat. des bas-reliefs*, pl. xxix [8, 9], pp. 18-19. See SCHMIDT, *Den Æg. Sam.* (1908), pp. 61-2 [E.15, 16].

Lintel with offering-text, Dyn. VI, Æ.I.N. 1447. KOEFOED-PETERSEN, *Cat. des bas-reliefs*, pl. xxvii [26], p. 28 (as 1446).

Pillar-fragment of Iryiry , Head of chamberlains of the Lord of the Two Lands, temp. Ramesses II, Æ.I.N. 45. KOEFOED-PETERSEN, *Cat. des bas-reliefs*, pls. lxxviii-lxxxii [77], pp. 58-9, 75. Two faces, MOGENSEN, *Coll. ég.* pl. cx [A 743], p. 102; SCHMIDT, *Choix* (1910), pl. xiii [27], pp. 27-8; id. *Levende og Døde*, fig. 507. Text, KOEFOED-PETERSEN, *Rec. inscr.* p. 81 [45]; part, SCHMIDT, *Den Æg. Sam.* (1908), pl. 8 [14], pp. 154-7 [E.91].

Mourning scenes, lake with island, etc., end of Dyn. XVIII or Dyn. XIX, Æ.I.N. 38 (including block formerly in Berlin Mus. 20365). MOGENSEN in *B.I.F.A.O.* xxx (1930), pl. i [4], pp. 458-9; id. *Coll. ég.* pl. ciii [A 704], pp. 95-6 with fig.; KOEFOED-PETERSEN, *Cat. des bas-reliefs*, pls. xxxiii-xxxv [36], pp. 33-4. Without block formerly in Berlin, MADSEN in *Å.Z.* 41 (1904), Taf. i, pp. 110-13; SCHMIDT, *Levende og Døde*, figs. 497-8; id. *Choix* (1910), pl. xiii [28], pp. 26-7; KOEFOED-PETERSEN, *Ægyptisk Billedhuggerkunst* (1951), pl. 23; id. *Æg. Sculpture* (1951), pl. 25; (1962), pl. 28; SÉE, *Grandes villes*, fig. on p. 163 [upper]. Male mourners, RADWAN in *Mitt. Kairo*, 30 (1974), Taf. 18 [b], p. 120 [2]. See SCHMIDT, *Den Æg. Sam.* (1908), pp. 157-9 [E.92].

Dayton (Ohio), Art Institute.

Male head, Dyn. V-VI, No. 72.49. *Gazette des Beaux-Arts*, lxxxix (1973), Supp. Feb. 1973, fig. 358; FAY in *The Dayton Art Institute. Bulletin*, 32 [1] (Dec. 1973), fig. 12, p. 10. See ib. 34 [2] (May 1976), p. 30; *The Art Quarterly*, xxxvi (1973), p. 112.

Detroit, Institute of Arts.

Mourners and offerings, end of Dyn. XVIII or early Dyn. XIX, No. 24.98 (probably from same scene as Moscow I.I.a.6008). J. W. in *Bulletin of The Detroit Institute of Arts of the City of Detroit*, vi (1925), p. 41 with fig., cf. p. 50; CAPART, *Documents*, i, pl. 58; PAVLOV in *Yearbook of the Pushkin State Museum of Fine Arts* (1939), pl. xli; *Treasures from The Detroit Institute of Arts* (1960), fig. on p. 18. See WERBROUCK, *Pleureuses*, p. 86.

Edinburgh, Royal Scottish Museum.

Negro groom and chariot horses, late Dyn. XVIII, No. 1961.438.

Florence, Museo Archeologico.

Four men and a female mourner, Dyn. XIX, No. 2581. Text, SCHIAPARELLI, *Mus. Arch. Firenze*, p. 338 [1604]; BEREND, *Principaux monuments*, p. 79. See MIGLIARINI, *Indication*, pp. 30-1.

Poultry-yard and storehouse, with text above, late Dyn. XVIII or Ramesside, found reused in a house near Castelfelfredo, so probably formerly in Acerbi Colln., No. 5412. SCHIAPARELLI, op. cit. pp. 314-15 [1588] with fig.; BEREND, op. cit. pp. 103-4 with fig.; WRESZ., *Atlas*, i. 395; PETRIE ITAL. photo. 165. See WIEDEMANN in *P.S.B.A.* xvii (1895), p. 156 [4]; CURTO, *A Ricordo di due Egittologi Dimenticati* [etc.] in *Atti del Convegno la Lombardia e l'Oriente*, June 11-15, 1962, p. 119 [c] (as 1542).

Frankfurt-am-Main, Liebieghaus.

Man in canoe from netherworld scene, late Dyn. XVIII, No. 270. KERN in *Jaarbericht Ex Oriente Lux*, No. 9 (1944), pl. i, pp. 56-60 [1]; WOLF, *Kunst*, Abb. 502; CURTO, *L'Egitto antico* (1961), Tav. 1, p. 84 [A]; HARI, *Horemheb*, fig. 21, pp. 78-80; BRUNNER-TRAUT, *Die Alten Ägypter*, Taf. 56; *Bildwerke aus dem Liebieghaus* (1962) and (1972), pl. 4. See *Städtische Galerie. Verzeichnis der ausgestellten Bildwerke* (1930), p. 43.

Hamburg, Hamburgisches Museum für Völkerkunde.

Drum of Akhtihotp, Judge and Boundary official, probably Dyn. V, C.4055. Upper part of woman embracing husband, Old Kingdom, No. 1115.05.

Hanover, Kestner-Museum.



Offering-bringer with ointment and cloth, end of Dyn. III or early Dyn. IV, No. 1957.75. WOLDERING, *Ausgewählte Werke der ägyptischen Sammlung* (1958), pl. 13; MUNRO in *Stadel-Jahrbuch*, N.F. 3 (1971), p. 22 [8] with fig. on p. 20. See WOLDERING, *Kestner-Museum 1889-1964*, p. 39 [9].

Upper part of man, Dyn. VI, No. 1955.51. See id. ib. p. 40 [11].

Havana, Museo Nacional.

Female mourners and son Ty , Scribe of recruits, with mummy, probably late Dyn. XVIII, Inv.2. *Palacio de Bellas Artes. Instituto Nacional de Cultura. Sala de Arte Antiguo . . . Colección Conde de Lagunillas* (1956), frontispiece; PRAT PUIG in *Revista del Instituto Nacional de Cultura*, i [3/4] (June-Sept. 1956), fig. on p. 3 [lower].



Heidelberg, Ägyptologisches Institut der Universität.

Sethes-ptah , Overseer of leather-workers, etc., and son Zay , Dyn. V, No. 34. OTTO (E.), *Aus der Sammlung des Ägyptologischen Institutes der Universität Heidelberg* (1964), Abb. 14, p. 92. Title of leather-worker, JUNKER, *Weta und das Lederkunsth Handwerk* [etc.] in *Sitzungsb. Wien*, 231 [1] (1957), Taf. i [a, 4], p. 13.

Leicester, Museums and Art Gallery.

Marsh-scene with man with lotuses and fish, and text, New Kingdom, No. 67.1918.

Leyden Museum.

Nefersethes . . . , Inspector, and wife Khentkaus , Prophetess of Hathor, two blocks from jambs, perhaps Dyn. IV, F.1939/2.5, 13 (formerly in von Bissing Colln. and The Hague, Scheurleer Mus.). VON BISSING in *Bull. Antieke Beschaving*, ix [2] (Dec. 1934), figs. 1, 2, pp. 3-4 [5, 6] (as Gîza).

Serefka , *warb*-priest, etc., drum, Old Kingdom, F.1939/2.16.



Sethes-ptah (same man as Heidelberg 34, see above), drum, Dyn. V, F.1939/2.14 (formerly in von Bissing Colln.). See id. ib. p. 3 note 4.

Donkeys threshing, Dyn. V, Inv.AM.102. LEEMANS, *Aeg. Mon.* i, pl. xxxv [5]; BOESER, *Beschreibung*, i, Taf. xxii; BREMMER, *Eg. kunst*, No. 4; *Gids* (1926), fig. on p. 14; (1928), fig. on p. 15; (1937), fig. on p. 17; WEIGALL, *Anc. Eg. . . . Art*, 53 [upper]; CAPART, *Memphis*, fig. 232; ROSS, *The Art of Egypt*, pl. on p. 114 [3]; FECHHEIMER, *Plastik* (1914), Taf. 119; (1923), Taf. 129; BRUNNER, *Ägyptische Kunst in Die Kunst dem Volke*, No. 85 (1937), Abb. 60; RANKE, *The Art of Ancient Egypt*, and BREASTED, *Geschichte Aegyptens* (1936), 211; WRESZ., *Atlas*, i. 100 [b]; BYVANCK, *De Kunst*, pl. xxii [81]; ERMAN and RANKE, *Aegypten und aegyptisches Leben im Altertum* (1923), Taf. 36 [2]; KLASSENS, *Egyptische kunst*, pl. 21; ASSELBERGHS, *Beeldende Kunst in Oud-Egypte*, fig. 15; WOLF, *Die Welt der Ägypter*, Taf. 32 [upper]; GALASSI in *Critica d'Arte*, n.s. ii (1955), fig. 261 on p. 329 [middle], cf. p. 313; *Artefact*, pl. 34, p. 33; PRITCHARD, *Anc. Near East*, fig. 89; Amsterdam. 5000 jaar, fig. 4 [18]; WOLDERING, *Götter*, Taf. viii on p. 67; POULSEN, *Äg. Kunst. A. und M.* pl. on p. 73; GROENEWEGEN-FRANKFORT and ASHMOLE, *Art of the Ancient World*, fig. 39; BRUNNER-TRAUT, *Die Alten Ägypter*, Taf. 11b; CRONSTRAND drawings, 221-63. See LEEMANS, *Descr. rais.* p. 41 [C.5].

Herdsmen in canoe with cattle crossing canal, Dyn. V-VI, F.1939/2.7 (formerly von Bissing Colln. and The Hague, Scheurleer Mus.). VON BISSING in *Bull. Antieke Beschaving*, ix [1] (June 1934), fig. 1, pp. 1-3 [1].

Carpenters, Dyn. XIX, Inv.AP.40. LEEMANS, *Aeg. Mon.* iii, pl. xxvii; BOESER, *Beschreibung*, iv, Taf. xxxvii [7] (called 6 in text); WRESZ., *Atlas*, i. 420. See LEEMANS, *Descr. rais.* p. 145 [K.17]; BOESER, *Cat.* (1907), p. 65 [58].

Linköping, Stifts- och Landsbibliotek.



Two Ramesside blocks, (a) . . . y , Royal scribe, with wife Ty , Songstress of the Mistress of the Sycamore, (b) Thoth (headless). SÄVE-SÖDERBERGH, *De egyptiska Reliefferna* [etc.] in *Linköpings Biblioteks Handlingar*, N.S. 4 [2] (1950), pls. 1, 2, pp. 1-6. (a) See Stockholm. 5000 år, No. 92.

Liverpool, School of Archaeology and Oriental Studies.

Akhtihotp , Judge and Boundary Official, Director of scribes of petitions, etc., lintel, Dyn. V, E.91.

London, British Museum.

ʿAnkh, Regulator of a phyle of the Pyramid of Shepseskaf, Dyn. IV (James) or later, No. 1234. *Hiero. Texts*, i², pl. xi [2], p. 11.

Hesi —, Royal acquaintance, panel with offering-text, probably Dyn. IV, No. 1212. Ib. i, pl. 21 [4]; i², pl. xiii [1], p. 13. See *Guide (Sculpture)*, p. 2 [4] (as Giza).

Funeral procession with men carrying chest and mourners, late Dyn. XVIII or early Dyn. XIX, No. 326 (formerly Athanasi Colln.). WERBROUCK, *Pleureuses*, pl. xlvii [lower], p. 90; MONTET, *Lives of the Pharaohs*, fig. on pp. 258-9; PIRENNE, *Hist. civ.* iii, pl. 50 after p. 196; EDWARDS in *Rev. d'Ég.* 27 (1975), pl. 9, pp. 117-24. See *Sotheby Sale Cat.* (ATHANASI), March 13-20, 1837, No. 134 (as Abydos); SHARPE, *Eg. Antiq.* pp. 100-1; *Guide (Sculpture)*, p. 237 [856].

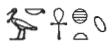
Nebmosi , Overseer of the Treasury, First prophet of Isis Mistress of *heb-sed*, etc., with wife Bektankhet  before him in double-scene, Dyn. XIX, No. 1465. See ib. p. 176 [635].

London, University College Museum.

Forecourt of a tomb, with statues, late Dyn. XVIII or XIX, No. 408. CAPART, *Recueil*, pl. xlii; UPHILL in *J.E.A.* 48 (1962), pp. 162-3 with fig.; STEWART, *Eg. Stelae*, i, pl. 53, p. 55. See *Handbook of Egyptian Antiquities . . . Petrie* (1915), No. 537.

Jamb of Ptaḥmosi , Greatest of the directors of craftsmen, etc., probably Dyn. XIX, No. 14477. STEWART, op. cit. pl. 43 [2], p. 53.

Marseilles, Musée d'archéologie.

Shepseskafʿankh , Royal acquaintance of the Great House, drum, Dyn. V, No. 220. *Le Nil et la société égyptienne* (Musée Borély, Marseille, 6 décembre 1972-1^{er} mars 1973), No. 88 with fig.; WILBOUR MSS. iii.D.12 [top]. Text, MASPERO in *Rec. Trav.* xiii (1890), p. 113 [20]. See id. *Catalogue du Musée Égyptien de Marseille*, p. 14 [20] (as Giza).

Moscow, State Pushkin Mus. of Fine Arts.

Mourners, end of Dyn. XVIII or early Dyn. XIX, I.1.a.6008 (probably from same scene as Detroit 24.98). *Kratkiy putevoditel' po muzeyu. Drevniy mir* (1956), fig. 8; PAVLOV, *Egipet. Putevoditel'* (1945), pl. 12; id. and MARČENKO in *Enciclopedia dell'Arte Antica Classica e Orientale*, v, fig. 335 on p. 243; *Gosudarstvennyy muzey izobrazitel'nykh iskusstv imeni A. S. Pushkina. Zhivopis', skul'ptura, prikladnoe iskusstvo* (1956), pl. 92; PAVLOV and MAT'É, *Pamyatniki iskusstva Drevnego Egipta* [etc.], pls. 54-5; MAT'É, *Iskusstvo Drevnego*

Egipta (1958), fig. 103; (1961), fig. 201; (1970), fig. 79; SHURINOVA, *Iskusstvo Drevnego Egipta*, pl. 94; KHODZHASH (S.) in *Byulleten' VOKS*, No. 8 (103) (Aug. 1956), pl. facing p. 29 [lower]; id. *Iskusstvo Drevnego Vostoka*, pl. 22; id. (= HODJACHE), *Les antiquités égyptiennes au Musée des Beaux-Arts Pouchkine*, pls. 20-1; KATSNEL'SON and others, *Kul'tura drevnego Egipta* (1976), fig. 77.

Munich, Staatliche Sammlung Ägyptischer Kunst.

Man carrying *zad*-pillar, end of Dyn. XVIII, ÄS 2971. *Staatl. Sammlung* (1976), pp. 101-2 with fig.

New York, Metropolitan Museum of Art.

Adjoining blocks of an Overseer of the Treasury of Snefru, Khufu, and Ra'zedef, etc., Nos. 04.2.4-6. WILBOUR MSS. 2 B, 192 [top and middle].

Block with head of ['Ankhn]a'ka [𓆎 𓆏] 𓆑, Dyn. VI, No. 66.99.151 (formerly in Gallatin Colln.). VON BOTHMER (D.), *Ancient Art from New York Private Collections* (Cat. Exhib. . . . Metropolitan Museum of Art, Dec. 17, 1959-Feb. 28, 1960), No. 62 with pl. 20.

Two registers of feeding cattle, and cargo-boats, late Dyn. XVIII, No. 21.2.25. HAYES, *Scepter*, ii, fig. 201; SÉE, *Grandes villes*, fig. on p. 254.

Paris, Louvre.

Khuenptah 𓆎 𓆏 𓆑, King's *warb*-priest, Prophet of Neferirkarē, lintel, temp. Neferirkarē or later, C 154 [N.322]. Name and titles, GAUTHIER, *Livre des Rois*, i, p. 117 [vi]. See DE ROUGÉ, *Notice des monuments* (1883), pp. 133-4.

Nikauinpu 𓆎 𓆏 𓆑, Inspector of the Great House, etc., drum, Dyn. V, C 156 [N.311]. WILKINSON MSS. xxiv. 11 [bottom right]. Text, PIERRET, *Rec. inscr.* ii, p. 69. See DE ROUGÉ, op. cit. p. 134.

Cooking and baking, Dyn. V, E.17499.

Two palm-columns, granite, Old Kingdom, usurped by Ramesses II. See VANDIER, *Guide* (1948 and 1952), p. 9; (1973), p. 14.

Three registers of mourners, late Dyn. XVIII, B 57 [E.11274]. VANDIER in *Mélanges Syriens offerts à Monsieur René Dussaud*, ii, pl. ii, pp. 816-17; CURTO, *L'Egitto antico* (1961), Tav. 4, p. 84 [F]; HARI, *Horemheb*, fig. 42, pp. 110-11; FAZZINI in *Miscellanea Wilbouriana*, 1 (1972), fig. 20, p. 53. See BOREUX, *Guide*, i, pp. 136-7; VANDIER, *Guide* (1948), pp. 17-18; (1952), p. 18; (1973), p. 28.

Shedsunefertem 𓆎 𓆏 𓆑, son of 'Ankhefensekhmet 𓆎 𓆏 𓆑, both Greatest of the directors of craftsmen, with Zeptahefankh, Lector-priest of Ptaḥ, etc., before Ptaḥ and Sekhmet, temp. Sesonchis I, E.25680. *Vingt ans*, p. 21 [Cat. 79] with pl.; VANDIER in *La Revue du Louvre*, 17 (1967), fig. 15, p. 309. See id. ib. 16 (1966), pp. 243-4.

Six blocks of Unnūfer, Prophet of Neith, Director of Selkis, son of Painmu 𓆎 𓆏 𓆑, probably Dyn. XXX, E.3065.

Richmond, Virginia Museum.

Architrave of Irenrē 𓆎 𓆏 𓆑 Ihy 𓆎 𓆏 𓆑, Judge and Boundary official, Overseer of the scribes of the land, etc., Dyn. VI, in two parts, Nos. 51.19.10 and 58.9 (formerly in MacGregor Colln., and right part in Sambon Colln.). *Ancient Art in the Virginia Museum* (1973), fig. on p. 22 [14], cf. p. 23; see *Sotheby Sale Cat.* (MACGREGOR), June 26-July 6, 1922, p. 204 [1575-6]. Right part, *Sotheby Sale Cat.* May 20-1, 1930, pl. v [327], p. 36; COHEN, *Egypte en Voor-Azië*, pl. 3; id. in *Bull. Antieke Beschaving*, vii [1] (June 1932), fig. 3, p. 8; SAMBON,

Aperçu général de l'évolution de la sculpture [etc.] (1931), pl. i; BOTHMER in *Arts in Virginia*, iii [1] (Fall 1962), fig. 2, p. 25; see *The Art Quarterly*, xxi (1958), p. 216.

Rome, Museo Barracco.

Overseer, calves, milking cow, and remains of building papyrus canoe above, Dyn. V-VI, No. 2. BARRACCO and HELBIG, *La Collection Barracco*, n.s. (1907), pl. i; BARRACCO, *Catalogo del Museo di Scultura Antica. Fondazione Barracco* (1910), p. 13 [2] with pl. facing p. 16; ALINARI photo. 34759; omitting canoe, RANKE, *The Art of Ancient Egypt*, and BREASTED, *Geschichte Aegyptens* (1936), 200. See PIETRANGELI, *Museo Barracco di Scultura Antica. Guida* (1949), p. 37; (1960), p. 49; (1963), p. 56.

Rovigo, Museo dell'Accademia dei Concordi.

Pillar of Iymery , Overseer of all trees of Memphis, etc., decorated on two faces, Dyn. V, No. 3. DOLZANI, *La Collezione Egiziana* [etc.], Tav. iv, pp. 9-10.

Stockholm, Medelhavsmuseet.

Ramesesnakht , Scribe of the office of presentation, etc., of Memphis, before man and wife seated, Ramesside, NME 26. PETERSON in *Medelhavsmuseet Bulletin*, 9 (1974), fig. 2, pp. 8-10. Text, MOGENSEN, *Stèles égyptiennes au Musée National de Stockholm*, pp. 50-1. See LIEBLEIN, *Katalog öfver egyptiska fornlemningar i National-Museum* (1868), p. 23 [26].

Remains of text, and five men with offerings, etc., below, Ramesside, NME 38 [MM 32012]. PETERSON in *Medelhavsmuseet Bulletin*, 5 (1969), fig. 2, pp. 5-6, 12.



Man carrying plants, Ramesside, NME 63 [MM 32016]. Id. ib. fig. 7, pp. 10-11.

Tübingen, Ägyptologisches Institut der Universität.

Sankhu-ḥathor , female dwarf, holding chest, perhaps Early Dynastic, Inv. 1098 (formerly in Michaelidis Colln.). KAPLONY, *Inschriften, Suppl.* Taf. v [1067], p. 33.

Block of an Inspector of prophets of the Pyramid of Teti, with remains of offerings, Dyn. V, Inv. 1768.

Uppsala, Victoriamuseum för Egyptiska Fornsaker.

Lintel-fragment of Duarēc  ⌘, Keeper of the gate, etc., and wife Shepsetkau , Dyn. VI, No. 9. LUGN, *Ausgewählte Denkmäler aus ägyptischen Sammlungen in Schweden*, Taf. xi, pp. 14-15 [15].

Three squatting sons of deceased, New Kingdom, B.63 (formerly in Mahler Colln.). MAHLER, *Beöthy Zsolt* [etc.], pp. 53-4 with fig. (as Dyn. V).

Vienna, Kunsthistorisches Museum.

Sakeḥ , Governor of Memphis, etc., in tree-goddess scene, and adoring, Ramesside, Inv. 5816. Text, REINISCH, *Miramar*, Taf. xxxix [D], p. 256 [21]; WRZESINSKI, *Aegyptische Inschriften aus dem K.K. Hofmuseum in Wien*, pp. 128-9 [1.32]. See *Uebersicht* (1895), p. 38 [163]; (1923), p. 13 [163].



Private Collections, dealers, etc.

Upper parts of Merneret-nesut  ⌘, Singer of the Great House, and female harpist,

Dyn. V, in Michaelidis Colln. GRDSELOFF MSS. I.102 (photo.).

Butcher and flutist, Dyn. V, formerly in von Bissing Colln. and The Hague, Scheurleer Mus., now in Van Leer Colln. 8*. VON BISSING in *Bull. Antieke Beschaving*, ix [1] (June 1934), fig. 3, pp. 3-4 [3]; *Jaarbericht Ex Oriente Lux*, No. 5 (1937-8), pl. xxx, p. 466; JANSSEN in *Mededelingen* [etc.], *Ex Oriente Lux*, No. 12 (1957), pl. iv, p. 17 [8*]; F.E.R.E. photo. 21457. See *Uit de Schatkamers der Oudheid. Jubileumtentoonstelling 1898-1938*. Stedelijk Museum, Amsterdam. 3 Sept.-16 Oct. 1938, pp. 60-1 [165].

Man with wine-jar, Dyn. V, in Baron Philippe de Rothschild Collection. SUTTON in *Apollo*, lxxviii (1963), fig. 1 on p. 172.

Lintel of Thenti , Overseer of craftsmen, and wife Ni'ankh-ḥathor , Dyn. V, formerly in Amherst Colln. WILKINSON MSS. xiii. 71 [bottom]. Text, CRUM in GARDINER Notebook, 66, p. 18 [lower]. Names, LIEBLEIN, *Dict.* No. 1407. See *Sotheby Sale Cat.* (AMHERST), June 13-17, 1921, No. 194.

Lintel of Ka'aper , Judge and Boundary official, Royal chamberlain, Prophet of Ḥeḳet, Dyn. V, and block with Senzemib standing, early Dyn. VI, both in Geneva, Fondation Martin Bodmer.

'Ankh-kakai , Royal acquaintance, with son, lower part of jamb, Dyn. V-VI, formerly in Hirsch Colln. *Antike Kunstwerke. Ars Antiqua AG Luzern Auktion*, May 2, 1959, Taf. 3 [5], p. 6.

Drum of Khuwiptah , Prophet of Ptaḥ and Sokari, etc., Dyn. V-VI. *Christie Sale Cat.* April 11, 1972, No. 167 with pl. xviii [lower]; Charles Ede Ltd. *Writing and Lettering in Antiquity* [1972], No. 20 with fig.

Zadshepses , Royal metal-worker, Inspector of sculptors, with family, and offering-bringers below, early Dyn. VI, formerly in Hirsch Colln. *Bedeutende Kunstwerke aus dem Nachlass Dr. Jacob Hirsch* (Auktion, 7. Dezember 1957, Luzern), Taf. 1, p. 7; F.E.R.E. photo. 16399.

Irti , Prophetess of Ḥathor, etc., late Dyn. VI. Block decorated on two faces, (a) man, (b) table, and female offering-bringer below, in Schimmel Colln.; *Man in the Ancient World* (Exhib. New York, Queens College, Flushing, Feb. 10-March 7, 1958), pl. 92, cf. Corrigenda; VON BOTHMER (D.), *Ancient Art from New York Private Collections* (Cat. Exhib. . . . Metropolitan Museum of Art, Dec. 17, 1959-Feb. 28, 1960), No. 63 with pls. 20-1; HOFFMANN, *Norbert Schimmel Collection* (1965), No. 83 with pl.; MUSCARELLA, *Ancient Art. The Norbert Schimmel Collection* (1974), No. 169 with pl. Another, in von Kienbusch Colln.

Remains of people squatting at tables with offerings and offering-bringers, Dyn. XII. *Antike Kunstwerke. Ars Antiqua AG Luzern Auktion*, May 14, 1960, Taf. 2 [3], p. 6.

Ptaḥmosi, Royal scribe, Steward, and wife (name lost), seated, being censured and libated to by son Amenḥotp, Scribe of troops of the *gb(w)*  of the Great House in Memphis, late Dyn. XVIII, in Acerbi Colln. at Castelgoffredo. CURTO, *A Ricordo di due Egittologi Dimenticati* [etc.] in *Atti del Convegno la Lombardia e l'Oriente*, June 11-15, 1962, pl. v [6], p. 118 [7].

Others.

Lintel-fragment of a Prophet of the Sun-temple of Userkaf, temp. Userkaf or later. PRISSE, *Mon.* p. 3 [middle]; MARIETTE, *Mastabas*, fig. on p. 445 [H 6]; NESTOR L'HÔTE MSS. 20396, 355.

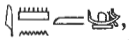

Three personifications of estates, end of Dyn. V. JACQUET-GORDON, *Domaines*, p. 397 [27S5].

Lintel of a Scribe of sacrificial cattle of the slaughterhouse of the god, etc., with address to passers-by, Dyn. V-VI, seen outside entrance to Step Pyramid enclosure in 1951. GARDINER MSS. photo. 28.491.

Block of Amenemwia , Chief steward, New Kingdom, seen in Maspero's house at Şaqqâra in 1881. WILBOUR MSS. 2 B, 170.

Blocks of Nekht-dḥout , Royal scribe, Overseer of the Two Granaries of Upper and Lower Egypt, etc., Ramesside, seen in magazine at Şaqqâra. Name and titles, HELCK, *Zur Verwaltung des Mittleren und Neuen Reichs*, p. 504 [20].

Various fragments, including blocks of Ḥaremḥab and Psammetikhos II, and of Amenakht, Overseer of the Treasury of the Lord of the Two Lands, etc., probably Ramesside. *L. D. Text*, i, p. 139 [middle].

Jamb with offering-text of Paser , Royal scribe, Overseer of the royal harîm, and blocks, including Opening-the-Mouth ceremony for Ptaḥmosi , Overseer of the cattle of Amûn, one with Ptaḥ and Sekhmet, and another with priests dragging sledge with chest with four sons of Horus, Ramesside, seen in 1856. WILKINSON MSS. xiii. 25-6.

Coffins and sarcophagi

Berlin Museum.

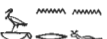
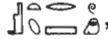

‘Ankh-ḥor , Head of servants, etc., son of Bekenrenef  and Ēsireshti , granite, Dyn. XXVI, No. 41 (East). Texts, WIEDEMANN in *P.S.B.A.* viii (1886), pp. 232-9; SEYFFARTH MSS. vi. 4324-65. Names and titles, LIEBLEIN, *Dict.* No. 1289. See *Ausf. Verz.* pp. 269-70.

Teti-ḥarsiēsi(?) (woman), wooden anthropoid coffin, Ptolemaic, No. 31. *Aeg. und Vorderasiat. Alterthümer*, Taf. 58; *Ausf. Verz.* Abb. 66, p. 342; SCHÄFER and ANDRAE, *Kunst*, Taf. xxv; ROSS, *The Art of Egypt*, pl. on p. 233; STRÖMBOM, *Egyptens Konst.*, fig. 221. Upper part, MAHAFFY, *A History of Egypt* [etc.], iv (1899), fig. 13; BEVAN, *A History of Egypt* [etc.], iv (1927), fig. 15.



Brooklyn Museum.



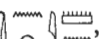

Dḥutardais, daughter of Pedēsi, coffin-lid, Late Period, No. 37.1521E (formerly in N.Y. Hist. Soc. Colln.). See *N.Y.H.S. Cat.* p. 26 [408].

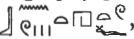

Cairo Museum.

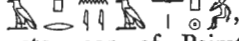
‘Ankh-ḥap , son of ‘Ankh . . .  and Tentamûn , lid-fragment, granite, probably Dyn. XXVII, CG 29311. MASPERO and GAUTHIER, *Sarcophages*, ii, pls. xvi, xvii, pp. 56-9 (texts).



Thaibastimu (woman), wooden coffin, Late Period, JE 35265. Name, see RANKE, *Die ägyptischen Personennamen*, i, p. 387 [18].



Ameniy , Bentehtuf , Prophet of Osiris, son of Mutiyti  (mother), anthropoid lid, Ptolemaic, Temp. No. 13.1.21.1. BUHL, *Sarcophagi*, fig. 52, pp. 90-2 [F, a 2], cf. pl. v. See MASPERO, *Guide*, p. 270 [1303]; DE MEULENAERE in *Bibliotheca Orientalis*, xvii (1960), p. 33 [Fa, 2].

Aperenyas-pakhem (i.e. Apollonius junior)  (also Peḥernüfer-pakhem )², Commander of the army, etc., son of Paimt  and Taremtenubaste , wooden coffin, Ptolemaic, JE 49532. Text, DARESSY in *Ann. Serv.* xvii (1917), pp. 2-5.



Haremḥab , Prophet, son of Therut  (mother), anthropoid, basalt, Ptolemaic, Temp. Nos. 22.1.21.3-4. Detail, LANZONE, *Diz.* Tav. cccxlvii, pp. 1014-15. Text, PIEHL, *Inscr. hiéro.* 3 Sér. il-lxix [E, G]; part, VON BERGMANN in *Rec. Trav.* vi (1885), p. 165 [bottom]. See BUHL, *Sarcophagi*, pp. 41-4 [E, a 4], cf. pl. ii; MASPERO, *Guide*, p. 271 [1306]. Squeezes of two details in Boston Museum, see DUNHAM in *J.A.O.S.* 56 (1936), p. 174 (Nos. 78.181 and 183).



Imḥôtep(?), anthropoid, Ptolemaic, JE 6401 (Temp. No. 3.1.21.12). BUHL, op. cit. fig. 56, pp. 93-4 [F, a 6].

Khaṣfi , son of Renpetnefert  (mother), wooden coffin, Ptolemaic, JE 49531. Texts, DARESSY in *Ann. Serv.* xvii (1917), pp. 5-20. Twelve hours of the day, BRUGSCH in *Ä.Z.* v (1867), pp. 22-6 with Taf. [A]; id. *Thes.* 56-8 [C]. Goose from the 12th hour, KUENTZ, *L'Oie du Nil*, fig. 29, p. 56. Wind-gods, BRUGSCH, *Thes.* 850 [iv].

Khons-ḥap , son of Tanebteḥ  (mother), rectangular wooden coffin, Ptolemaic, CG 29323. MASPERO and GAUTHIER, *Sarcophages*, pls. xlii, xliii, pp. 138-47.

Ptaḥḥotp, Secretary of the Temple of Ptaḥ, etc., son of Nakhtes  (mother), anthropoid lid, Ptolemaic, Temp. No. 3.3.21.8. BUHL, op. cit. fig. 57, pp. 95-6 [F, a 9], cf. pl. v.

Unnüfer , Prophet, Royal scribe, son of Nebt-ḥyt  (mother), lid, Ptolemaic, CG 29310. MASPERO and GAUTHIER, op. cit. pls. xiii-xv, pp. 42-55. Vertical and horizontal text in the centre, PIEHL, *Inscr. hiéro.* 1 Sér. xxxvii-xil [A]; DEVÉRIA squeezes, 6166, ii. 115; vertical, MARIETTE, *Mon. div.* pl. 59; BRUGSCH, *Thes.* 741-3; cols. 2 and part of 3, VANDIER, *La famine dans l'Égypte ancienne*, pp. 129-30. Six squeezes in Boston Museum, see DUNHAM in *J.A.O.S.* 56 (1936), p. 174 (Nos. 78.145 and 147).

Zehō , Prophet of various divinities, etc., son of Weḥebrēc-merneit , Prophet of Thoth, and Wazetiyt , anthropoid lid, Ptolemaic, Temp. No. 13.1.21.2. Text, WILBOUR MSS. iii.B.1. See BUHL, op. cit. pp. 96, 98 [F, a 10], cf. pl. v (called 13.1.2.2).

Gotha, Schlossmuseum.

Anthropoid lid fragment, inscribed, green schist, Ptolemaic, No. 16 Ae. See BUBE, *Das Herzögl. Kunst-Kabinet zu Gotha* (1869), p. 2 [25]; WENIG, *Ägyptische Sammlung (Museen der Stadt Gotha. Schlossmuseum Schloss Friedenstein)*, No. 17.

Leyden Museum.



Minnüfer , Chief Justice and Vizier, etc., outer granite and inner limestone sarcophagi, temp. Neuserre, Inv.AMT.106. LEEMANS, *Aeg. Mon.* iii, L.1, 2, pls. i, ii; BOESER, *Beschreibung*, i, pl. xxx; CAPART, *Recueil*, pl. xiv; DONADONI ROVERI, *Sarcophagi egizi*, Tav. xxxiv, p. 129 [B 50]; *Gids* (1926), fig. on p. 56; (1928), fig. on p. 61; (1937), fig. on p. 81. See PLEYTE, *L'Art antique égyptien dans le Musée de Leide in Verhandlungen des VII. internationalen Orientalisten-Congresses . . . Wien . . . 1886*, Ägyptisch-Afrikanische Section, pp. 47-8 [1]; LEEMANS, *Descr. rais.* p. 146 [L. 1, 2]; BOESER, *Cat.* (1907), p. 30 [9].



London, British Museum.



Irterau , son of Serseru , inner wooden anthropoid coffin, Dyn. XXVI, No.





6695 (formerly in Lethieullier Colln.) (moved here from *Bibl. i.*² 828). GORDON, *Twenty-five Plates*, pls. xi, xii, and *An Essay Towards Explaining the Hieroglyphical Figures, on the Coffin of the Ancient Mummy Belonging to Capt. William Lethieullier* (1737). Names, DAWSON and GRAY, *Catalogue of Egyptian Antiquities in the British Museum*, i, *Mummies and Human Remains*, p. 20 [36 note 1]. See PETTIGREW, *A History of Egyptian Mummies* [etc.] (1834), pp. 120-1; SHARPE, *Eg. Antiq.* pp. 168-9 [59]; *Guide, 1st to 3rd*, pp. 93-4.

Marseilles, Mus. d'archéologie.



‘Ankh-ḥap , Royal herald, Prophet, son of Tadeusiri  (also Tentusiri ) (mother), anthropoid, schist, Ptolemaic, No. 266. BUHL, *Sarcophagi*, fig. 27, pp. 59, 61 [E, a 23], cf. pl. iii; WILBOUR MSS. iii.D.1-2. One scene, LANZONE, *Diz.* Tav. ccxciii [1], p. 801. Text, MASPERO in *Rec. Trav.* xxxvii (1915), pp. 4-6 [66]. See id. *Catalogue du Musée Égyptien de Marseille*, pp. 48-9 [66].

Khet , son of Pameriun(?) , wooden lid of rectangular coffin, Ptolemaic, No. 263. Text, id. in *Rec. Trav.* xxxvii (1915), pp. 3-4 [63]. See id. *Catalogue* [etc.], p. 47 [63].



Pedeḥarneziotef , son of Tanubenwaskhet  (mother), wooden anthropoid coffin, hieroglyphic and demotic texts, Ptolemaic, No. 264. Some texts, id. in *Rec. Trav.* xxxvii (1915), p. 4 [64]. See id. *Catalogue* [etc.], p. 47 [64].

Penēsi , Prophet of Sokari in Asyût, etc., son of Smataui  and Tasmataui , re-used by Pedusiri, Prophet, Royal scribe, son of Pedeḥarpekhrod and Pesedet , anthropoid, basalt, Ptolemaic, No. 267. BUHL, *Sarcophagi*, fig. 28, pp. 61-4 [E, a 24], cf. pl. iii; SCHMIDT, *Levende og Døde*, figs. 1224-5. Two ram-headed gods, LANZONE, *Diz.* Tav. ccxciv, pp. 802-3. Some texts and scenes, WILBOUR MSS. iii.D.17-23, and 3 C.237-8. Texts, MASPERO in *Rec. Trav.* xxxvii (1915), pp. 7-16 [67]; some, BRUGSCH, *Thes.* 1417 [bottom]-1418 [upper] (seen at Luxor in 1858). See MASPERO, *Catalogue* [etc.], pp. 49-53 [67].



New York, Metropolitan Museum of Art.



Zehō , Royal scribe, Prophet of Min, etc., son of Tak'as  (mother), anthropoid, Ptolemaic, No. 11.154.7. BUHL, op. cit. fig. 69, pp. 117-18 [F, b 6], cf. pl. vii.

Norwich, Castle Museum.



Herib , son of Sedem'ash  and Shepenēsi , wooden anthropoid coffin, Dyn. XXVI, No. 242.27. Interior, GRIFFITH INST. photo. 379. See DAWSON in *J.E.A.* xv (1929), pp. 186-8.

Paris, Louvre.

‘Ankh-ḥap , Prophet of the King of Upper and Lower Egypt Snefru, *w nrw*-priest in Letopolis, etc., son of Ḥar-imḥōtep  and Setyerboni , anthropoid, basalt, Ptolemaic, D 13 [N.349]. BUHL, *Sarcophagi*, figs. 30, 60, pp. 104-5 [F, a 18], cf. pl. vi. Text, PIEHL, *Inscr. hiéro.* 1 Sér. xix-xx [G]; DEVÉRIA squeezes, 6166, ii. 117; some, PIERRET, *Rec. inscr.* ii, p. 16 (called D 12); BRUGSCH, *Thes.* 1256-7 [xii] (as A 13). Names and titles, LIEBLEIN, *Dict.* No. 1055. See DE ROUGÉ, *Notice des monuments* (1883), pp. 183-4; BOREUX, *Guide*, i, p. 115; VANDIER, *Guide* (1948 and 1952), p. 20; (1973), p. 44.

Zehō , Prophet of the statues of the King of Upper and Lower Egypt Psammetikhos (probably I) in the Temple of Memphis, etc., son of Pedeḥeka , *w nrw*-priest, etc., and Tashe(n)tiḥet , granite, Dyn. XXVI, D 8 [N.344]. SCHMIDT, *Levende og Døde*,



figs. 1208-9, 1218; *Encycl. phot. Louvre*, i, pls. 142-5; RICHER, *Le Nu*, figs. 164-7; details, DURANTY in *Gazette des Beaux-Arts*, xx (1879), fig. on p. 325; LANZONE, *Diz.* Tav. cxi; GIEDION, *The Eternal Present*, ii, fig. 74; WESTENDORF, *Das Alte Ägypten*, fig. on pp. 210-11; YOYOTTE, *Treasures*, pl. on p. 209. Text, DEVÉRIA squeezes, 6163A. Names and titles, BRUGSCH, *Thes.* 948 [14], 1463 [122] (as D 13); LIEBLEIN, *Dict.* No. 1192; REVILLOUT in *Revue Égyptologique*, vi (1891), p. 131 note 3. See DE ROUGÉ, *Notice des monuments* (1883), pp. 178-9; BOREUX, *Guide*, i, pp. 110-12; VANDIER, *Guide* (1948 and 1952), p. 22; (1973), pp. 39-40.

Zehō , Royal scribe of accounts of everything in the Temple of Imḥōtep son of Ptaḥ, etc., son of Pedepamenkhib  and Renpetnefert , basalt, Ptolemaic, D 9 [N.345]. SHARPE, *Eg. Inscr.* 2 Ser. 1-21; BOREUX, *Guide*, i, pl. xi, pp. 112-13; SCHMIDT, *Levende og Døde*, figs. 1210-11; BÉNÉDITE in *La Revue de l'Art ancien et moderne*, xliii (1923), fig. on p. 293; *Encycl. phot. Louvre*, i, pls. 146-55; DEVÉRIA squeezes, 6163A; 6166, ii. 120; 6169, ii. 67; 6170D, 17; Gal. Nat. Londres, 27; ARCHIVES phot. E.608. Details, WILKINSON, *M. and C.* 2nd Ser. Supp. pl. 87 = ed. BIRCH, iii, pl. lxx facing p. 466; PIANKOFF in *Ann. Serv.* xl (1940), pls. lxxi, lxxii [left], pp. 666-7; lv (1958), pl. iii, p. 159; DESROCHES, *L'Art égyptien au Musée du Louvre* (1941), fig. on 31st p. [lower]; id. and DU BOURGUET, *L'Art égyptien*, pl. xxxviii; BOREUX, *Sculpture*, pls. xli, xlii; BYVANCK, *De Kunst*, pl. lxix [234]; *L'Égypte: Art et Civilisation*, Sér. 57 (1951), pl. 2; WILKINSON MSS. iii. 11 [top], and xvii. C. 8 (squeezes); WILLIAMS rubbings, iii. 95 (cast). Texts, GOODWIN MSS. 31279, 10-11 (6), 14-15 (9), 47-50 (19). See DE ROUGÉ, *Notice des monuments* (1883), pp. 179-81; VANDIER, *Guide* (1948 and 1952), p. 22; (1973), pp. 39-40; WILDUNG, *Imhotep und Amenhotep*, pp. 57-8 [34].



Stockholm, Medelhavsmuseet.

Sit-khemtu (nu) , (woman), rectangular wooden coffin, 1st Int. Period, MM 11399. Name, PETERSON in *Orientalia Suecana*, xix-xx (1970-1), pp. 5-6 [vi].



Trier, Rheinisches Landesmuseum.

Pesteucaunu , daughter of Ḥarwoz , Prophet of Monthu Lord of Thebes, wooden anthropoid coffin, 3rd Int. Period, G. 536. HETTNER, *Illustrierter Führer durch das Provinzialmuseum in Trier* (1903), p. 46 [77] with fig. Names, WIEDEMANN in *P.S.B.A.* xi (1889), p. 74 [3]. See SCHNEEMANN in *Jahresbericht der Gesellschaft für nützliche Forschungen zu Trier über die Jahre 1859 und 1860*, pp. 88-90 [3].

Uppsala, Victoriamuseum för Egyptiska Fornsäker.



Irtenḥarerau , son of Taremtenubastē , (mother), anthropoid lid, Ptolemaic, No. 10. BUHL, *Sarcophagi*, fig. 51, p. 90 [E, b 25]. Text, VASSALLI MSS. 46 [right].

Vienna, Kunsthistorisches Museum.

Panehemēsi , son of Taneferḥeret , (mother), anthropoid, basalt, Ptolemaic, Inv.4. VON BERGMANN in *Jahrbuch der Kunsthistorischen Sammlungen* [etc.], i (1883), Taf. i, pp. 1-40; ii (1884), pp. 1-20; BUHL, *Sarcophagi*, fig. 76, pp. 127-34 [H, 5], cf. pl. ix; Vienna. 5000 Jahre, No. 211 with Abb. Some texts, WRESZINSKI, *Aegyptische Inschriften aus dem K.K. Hofmuseum in Wien*, pp. 153-74; VON BERGMANN in *Sitzungsb. Wien*, lxxxii [1] (1876), pp. 73-88, 92; id. in *A.Z.* xviii (1880), pp. 87-9; H. BRUGSCH in *ib.* i (1863),





pp. 29-30, 41-2; xvii (1879), pp. 20 [bottom], 29 [top]; id. in *Revue Égyptologique*, i (1880), p. 41; DUEMICHEN in *A.Z.* iii (1865), p. 3; LAUTH, *Alexander in Aegypten in Abhandlungen der königl. bayer. Akademie der Wissenschaften*, Philos.-philol. hist. Classe, xiv [1] (1876), pl. at end [4], p. 112; with some scenes, BRUGSCH, *Thes.* 726 [15], 848; WILKINSON MSS. xiii. 66-8 [top]. Two Wind-gods, LANZONE, *Diz.* Tav. clxxxiii [2], ccxiii [1], pp. 490, 558. See *Uebersicht* (1895), p. 34 [xx]; (1923), p. 10 [xx].



Washington (D.C.), United States National Museum.



Eshor , son of Tefnut  (mother), cartonnage-fragment, Dyn. XXVI, No. 1415. PICKERING, *The Gliddon Mummy-case in the Museum of the Smithsonian Institution in Smithsonian Contributions to Knowledge*, No. 208 (1869), passim with pl.; SCHMIDT, *Levende og Døde*, fig. 1258; DINSMOOR in *Proceedings of the American Philosophical Society*, 87 [1] (1943), fig. 16 facing p. 91, cf. p. 97 (last two references from PICKERING). See RANSOM WILLIAMS in *The New-York Historical Society Quarterly Bulletin*, iv [1] (April 1920), pp. 7-8; CASANOWICZ, *The Collections of Old World Archeology* [etc.] in *Annual Report . . . The Smithsonian Institution* (1922), pp. 453-4.



Others.

Nubiysi , daughter of Hori, late New Kingdom. CAIRO, CENTRE OF DOCUMENTATION photo. S.A., 2576.

Pedekhons  Pefteu'auenkhons , Head of dancers of Great Mut Mistress of Asher, etc., son of Hepmen  and Tent-hor , perhaps Dyn. XXX. Names and titles, and names of twelve goddesses with disks, DE ROUGÉ, *Inscr. hiéro.* pl. cii.

Tarepet , daughter of Pedekhonsiy , Prophet of Isis, basalt sarcophagus, Ptolemaic, in magazine at Şaqqâra in 1934-5.

Tesnakht , daughter of Zeamūnef'ankh  and Ta'arwoz , Dyn. XXVI. Text, MARIETTE, *Mon. div.* pl. 62 [a].

Weḥebrēc , Royal scribe, son of Ḥarḥatbeḥes , Dyn. XXVI. Texts of twelve fragments, DEVÉRIA squeezes, 5373B.

Son of Pefteu'(au)shu , wooden anthropoid coffin, Late Period or Ptolemaic, brought to England in about 1734, at one time in Mead Collection. GORDON, *Twenty-five Plates*, pl. xiii, and *An Essay Towards Explaining the Antient Hieroglyphical Figures, on the Egyptian Mummy, in the Museum of Doctor Mead* [etc.] (1737).

Wooden anthropoid coffin and cartonnage, both inscribed, Ptolemaic, brought by Perry to England in 1741, coffin afterwards in Lee and Amherst Collns. PERRY, *A View of the Levant* (1743), pl. 18, pp. 470-3. Coffin, PETTIGREW, *A History of Egyptian Mummies* [etc.] (1834), pl. vi [4], pp. 122-3. *Sotheby Sale Cat.* (AMHERST), June 13-17, 1921, pl. x [348], p. 35; see [BONOMI], *Cat. . . Hartwell House*, pp. 87-8 [589-90].

Anthropoid coffin and cartonnage, inscribed, Ptolemaic, brought by Pococke to Lord Charles Cavendish. POCOCKE, *A Description of the East* (1743), i, pl. xx facing p. 53.

Texts of two, Late Period or Ptolemaic, MARIETTE, *Mastabas*, pp. 448 [H 7], 459 [H 17].

Offering-tables and basins (including ointment-slabs)

Berlin Museum.

Kai , Overseer of metal-workers, etc., Dyn. V-VI, No. 7723. MARIETTE, *Mastabas*, fig. on p. 440 [j]. Text, *Aeg. Inscr.* i, p. 61. See *Ausf. Verz.* p. 65.

Brooklyn Museum. All formerly in N.Y. Hist. Soc. Colln.

Kaemthenen , Smelter, *mhnk* of the King, Dyn. VI, No. 37.1495E. Text, JAMES, *Corpus*, i, pl. xxvi [72], p. 30. See *N.Y.H.S. Cat.* p. 13 [165].

Manūfer , Prophet of Rē in the Sun-temple of Userkaf, etc., Dyn. V, No. 37.1497E. SHARPE, *Eg. Inscr.* 2 Ser. 41 [top right, omitting text in centre]. Text, JAMES, op. cit. pl. xviii [33], p. 12; LIEDER squeezes, 14. See *N.Y.H.S. Cat.* p. 13 [167].

Neferka , Scribe of the troop (*tst*), etc., Dyn. VI, No. 37.1496E. Text, JAMES, op. cit. pl. xxix [76], p. 31. See *N.Y.H.S. Cat.* p. 12 [164].

Cairo Museum.

Abeb , Lector-priest, etc., alabaster, Dyn. V-VI, CG 1341. MARIETTE, *Mastabas*, fig. on p. 436 [c]. Text, BORCHARDT, *Denkmäler*, i, pp. 19-20.

‘Ankh-meryrē , and Khuy , Dyn. VI, JE 43881.

‘Aperef , Assistant of Duau, Dyn. VI or later, CG 1331. Text, id. ib. p. 15.

Ḥetepka-khufu , Lector-priest, etc., perhaps Dyn. V, CG 1324. MARIETTE, op. cit. fig. on p. 439. Text, BORCHARDT, op. cit. pp. 10-11.

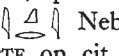
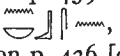
Ikri , Nebsen , Lector-priest, etc., alabaster, Dyn. V-VI, CG 1340. MARIETTE, op. cit. fig. on p. 436 [d]. Text, BORCHARDT, op. cit. p. 19.

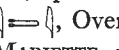
Ithi , Overseer of the scribes of the land of the Sebennite nome, Dyn. V-VI, CG 1346. MARIETTE, op. cit. fig. on p. 437 [e]. Text, BORCHARDT, op. cit. p. 21.

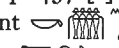
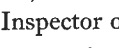
Kakhentiu , Kakhent , Inspector of the boat, Overseer of the six of the boat, etc., and wife Thenteti , Prophetess of Ḥathor, etc., two, Dyn. V-VI, CG 1352, 1356. Texts, id. ib. pp. 24, 26.

Khnemankhu , Overseer of the Palace (*dbt*), Dyn. IV(?), CG 1363. MARIETTE, op. cit. fig. on p. 438 [g]. Text, BORCHARDT, op. cit. p. 29.

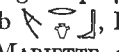
Merib , Royal acquaintance of the Great House, Dyn. V, CG 1343. Id. ib. Bl. 6, p. 20; MARIETTE, op. cit. figs. on pp. 435 [a], 441. Name and title, DE ROUGÉ, *Inscr. hiéro.* pl. lvi [top left].

Nakht, Prophet of Ptaḥ, Dyn. VI, JE 19179.

Neferiru , Old Kingdom, CG 1350. BORCHARDT, op. cit. Bl. 6, p. 23.

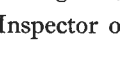
Nezemib , Inspector of tenants of the Great House, etc., Dyn. VI, CG 1369. Id. ib. Bl. 7, p. 32.

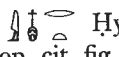
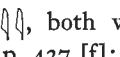
Ni'ankh-ḥathor , and Iynfert , Hy , both women and Royal acquaintances, Dyn. V, CG 1348. MARIETTE, op. cit. fig. on p. 437 [f]; CAIRO, CENTRE OF DOCUMENTATION photo. S.A., 2306. Text, BORCHARDT, op. cit. pp. 22-3. Names and titles, DE ROUGÉ, *Inscr. hiéro.* pl. lii [bottom].

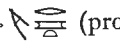
Peru , *ka*-servant, and (probably wife) Mert-min , (probably also called Ḥenutsen), Dyn. V(?), CG 1366. BORCHARDT, op. cit. Bl. 7, p. 30.

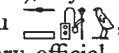
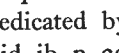
Seshu , Scribe of the archives, dedicated by son Thenti , Judge and Boundary official, Dyn. IV, CG 1365. Text, id. ib. p. 29. Dedication, SETHE, *Urk.* i. 228 [5 (145), F].

No name, alabaster, Old Kingdom, CG 1342. MARIETTE, op. cit. fig. on p. 440 [k]. Text, BORCHARDT, op. cit. p. 20.

Copenhagen, Ny Carlsberg Glyptothek.

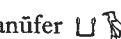
Kanūfer , Overseer of craftsmen, etc. (same man as Brit. Mus. 29207, see *infra*),

Dyn. VI, Æ.I.N. 1551 (formerly in Amherst Colln.). KOEFOED-PETERSEN, *Cat. des bas-reliefs*, pl. lxxxv [86], p. 62 (called Dyn. XVIII–XIX). Text, CRUM in GARDINER Notebook, 66, p. 17 [lower]. See *Sotheby Sale Cat.* (AMHERST), June 13–17, 1921, No. 205 [1st item].

Heidelberg, Ägyptologisches Institut der Universität.

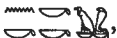
Nikaunebti , Royal acquaintance, Dyn. V, Inv.908. DE RICCI MSS. D.43.

Leningrad, State Hermitage Museum.

Ptahshepses, Overseer [of prophets] of the Pyramid of Userkaf, Dyn. V, No. 18106 (formerly in Hilton Price Colln.). See HILTON PRICE, *A Catalogue of the Egyptian Antiquities* [etc.], i (1897), p. 223 [2058]; *Sotheby Sale Cat.* (HILTON PRICE), July 12–21, 1911, No. 236.

Menekh-ishet , Judge and Master of the largesse, etc., Old Kingdom, No. 2261. Text, STRUVE, *Etyudy po istorii Severnogo Prichernomor'ya, Kavkaza i Sredney Azii*, pp. 305 [56], cf. 290–1. See GOLÉNISCHEFF, *Inventaire de la collection égyptienne* (1891), p. 327.

Leyden Museum.

, Overseer of *warb*-priests, Early Dynastic, F.1939/2.4.

Nebtka , Royal acquaintance (woman), Old Kingdom, F.1939/2.9.

S'ankhnesi , *warb*-priest, late Old Kingdom or 1st Int. Period, F.1939/2.12.

London, British Museum.

Two, Ipi , Prophetess of Neith, etc., Dyn. VI, No. 29208, and Kanüfer (same man as Copenhagen, Ny Carlsberg Glypt. Æ.I.N. 1551, see *supra*), Dyn. VI, No. 29207 (both formerly in Amherst and Bethell Collns.). *Hiero. Texts*, i², pl. xl [3, 2], pp. 43, 42. Text, CRUM in GARDINER Notebook, 66, pp. 14 [bottom], 15 [upper]. See *Sotheby Sale Cat.* (AMHERST), June 13–17, 1921, No. 204; Dec. 15–17, 1924, No. 391.

Sonb , Overseer of the store-room, Dyn. VI, No. 1179. *Hiero. Texts*, i², pl. xxxix [2], pp. 41–2. See *Guide (Sculpture)*, p. 28 [95].

London, University College Museum.

Nüfer , Barber, Prophet of Rē in the Sun-temple of Userkaf, etc., Dyn. V–VI, No. 19658 (formerly in MacGregor and Gordon-Bois Collns.). Text, ČERNÝ Notebook, 49, p. 82 verso [bottom]. See *Sotheby Sale Cat.* (MACGREGOR), June 26–July 6, 1922, p. 207 [1595]; June 10, 1947, No. 104.

Others.

Irti , King's adorer (woman), and others, Dyn. VI. HASSAN, *Giza*, v, fig. 33, p. 185.

Khemtnu , Elder of the house, etc., Dyn. V–VI. Name and titles, MARIETTE, *Mastabas*, p. 442 [n].

Khui , [Judge] and Real keeper of Nekhen, probably alabaster, Dyn. VI. FISCHER in *Metropolitan Museum Journal*, 9 (1974), fig. 7, p. 11 with note 30.

Shemsetka , Prophetess of Ḥathor, etc., Dyn. V–VI. Name and titles, MARIETTE, *op. cit.* p. 442 [m].

Sitmert , Royal acquaintance (woman), Dyn. V-VI. SHARPE, *Eg. Inscr.* 2 Ser. 41 [top right, centre]; LIEDER squeezes, 15.

Various

Pyramidia.

Amenhotp Huy , Governor in Memphis, granite, temp. Ramesses II, in Cairo Mus. Temp. No. 7.11.24.1. GRDSELOFF MSS. 3.6.3-6 (photos.).

Ptaḥemwia, Overseer of the fillet(?) of the Lord of the Two Lands, etc., Dyn. XIX, in Cairo Mus. CG 17109 (JE 8371).

Ptaḥmosi with wife Nefertiti, and Taya , Overseer of builders of the Pharaoh, Ramesside, in Louvre, D 20 [N.361]. ARCHIVES phot. E.806. See DE ROUCÉ, *Notice des monuments* (1883), p. 188; VANDIER, *Guide* (1948), p. 23; (1952), p. 24.

. . . mosi, New Kingdom, in Cairo Mus. JE 48841.

Boxes.

Wooden box containing table with model ritual implements and tools, of a Noble of the King (name lost), 1st Int. Period, in Cairo Mus. CG 1765. BORCHARDT, *Denkmäler*, ii, Bl. 101, pp. 183-6.



Wooden toilet-box with frieze of animals, late Dyn. XVIII, formerly in MacGregor Colln., now in Boston Mus. 49.493. NAVILLE in *Rev. Arch.* 3 Sér. xxxiii (1898), figs. 1, 3, 4, pp. 1-11; CAPART, *L'Art et la parure féminine* in *Annales de la Société d'Archéologie de Bruxelles*, xxi [3 and 4] (1907), pl. iv, p. 13; *Sotheby Sale Cat.* (MACGREGOR), June 26-July 6, 1922, pl. xv [548], xx [548], p. 68; SMITH, *Anc. Eg.* (1952), fig. 63; (1960), fig. 87; id. in *Boston Mus. Bull.* 1 (1952), figs. 1, 2, 5, pp. 74-7; TERRACE in *The Connoisseur*, clxix (1968), fig. 16, p. 56; details, SMITH, *Country Life*, fig. 25.



Wooden toilet-box of Ipy , Servant, with female musicians and dancers, late Dyn. XVIII, formerly in N.Y. Hist. Soc. Colln., now in Brooklyn Mus. 37.600E. CAPART, *L'Art ég.* iv, pl. 747; RIEFSTAHL, *Toilet Articles from Ancient Egypt*, pl. 11 [lower]; *Art of Ancient Egypt* (Emily Lowe Gallery, Hofstra University, Hempstead, New York, Feb. 22-April 6, 1971), No. 24 with fig. Text, JAMES, *Corpus*, i, pl. lxxxiv [427], pp. 173-4. See *N.Y.H.S. Cat.* p. 29 [461].

Canopic-jars.



In Cairo Museum. Late Period unless otherwise stated.





Amenmosi , Royal scribe, General of the Lord of the Two Lands, alabaster, Dyn. XIX, CG 4330 (another, formerly in Hoffmann Colln., see *infra*). Text, REISNER, *Canopics*, p. 225.

ʿAnkh-psammethk , God's father, son of Thaenḥab  (mother), alabaster, Dyn. XXVI, CG 4153-6. Id. ib. pl. xxii, p. 108-11. Texts, PIEHL, *Inscr. hiéro.* 1 Sér. lxxx [P-S].

Ḥarbes , son of Ikenwesh  and Tapert , alabaster, CG 4157-60. REISNER, op. cit. pl. xxiii, pp. 111-16.

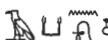
Ḥaremakhet , God's father, etc., four jars with lids, alabaster, CG 4130-5. Id. ib. pl. xix, pp. 92-6.

Ḥarwoz , son of Ir  and Zewertesʿankh , one jar and two lids, alabaster, CG 4288-9. Id. ib. pls. liii, lxix, pp. 196-8.

Ikenwesh , son of Harbes  and Mer(t)ptah , perhaps re-used by wife Tapert , CG 4393. Text, id. ib. p. 246.

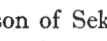
Iraḥor , God's father, son of Sekhmetnefert  (mother), alabaster, CG 4098-101. Id. ib. pl. xiv, pp. 63-6. See id. in *A.Z.* xxxvii (1899), p. 69.

Irefaenptah , God's father, *sem*-priest, son of Pedēsi, alabaster, CG 4106-9. Id. *Canopics*, pl. xv (CG 4108-9), pp. 70-4.

Kay , Head of door-openers, three jars and lids, faience, Ramesside, CG 4220-4. Id. ib. pls. xxxiii, xxxiv, pp. 154-8.

Nay , (woman), alabaster, Dyn. XVIII, CG 4094-7. Id. ib. pl. xiii, pp. 59-62. Texts, PIEHL, *Inscr. hiéro.* I Sér. lxxviii [C-F].

Nac . . . , one jar and four lids, CG 4389-92. See REISNER, op. cit. pp. 244-5.

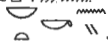
Nebtkenb , (woman), pottery, Dyn. XVIII-XIX, CG 4208. Id. ib. pl. xliv, pp. 150-1.

Nezem , Overseer of the Granary of the Lord of Upper and Lower Egypt, etc., alabaster, temp. Ramesses II, CG 4161-4. Id. ib. pl. xxiv, pp. 116-20; id. in *A.Z.* xxxvii (1899), fig. 5 [except middle] (lids and CG 4163, 4161), p. 67 [24].

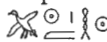
Paraemḥab , Great overseer of the cattle of Amūn, alabaster, probably Dyn. XIX, CG 4322-3 (another, in New Haven, Yale Univ. Art Gallery, 13.1.1953, see *infra*). Id. *Canopics*, pls. liv, lvii, pp. 218-20.

Paser , Governor of the town and Vizier (presumably same as owner of Theb. tb.106), alabaster, temp. Sethos I to Ramesses II, CG 4325-6. Id. ib. pl. lxiv, pp. 221-2 (texts); id. in *A.Z.* xxxvii (1899), fig. 5 [middle], pp. 66-7 [21].

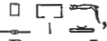
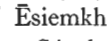

Pedeamūn, son of Ēsi(em)khebi , (mother), alabaster, CG 4294-6 (another in Alexandria, Graeco-Roman Museum, see *infra*). Texts, id. *Canopics*, pp. 201-3.

Pespermeh , son of Ēsiemkhebi , (mother), alabaster, CG 4102-5. Texts, PIEHL, *Inscr. hiéro.* I Sér. lxxix-lxxx [L-O]. See REISNER, op. cit. pp. 66-70 (texts, as Pespershed).

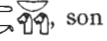

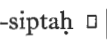
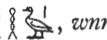
Psammethek, son of Tadeusiri , (mother), alabaster, CG 4145-8. See id. ib. pp. 103-6 (texts).

Psammethek-nebpeḥti , son of Pedeneit, alabaster, CG 4270-3. Texts, id. ib. pp. 185-7.

Psammethek-siptah , *wnrw*-priest in Letopolis, etc., son of Renpetnefert , (mother), alabaster, Dyn. XXVI, CG 4297-9 (another in Manchester, Univ. Mus. 11098, see *infra*). Texts, id. ib. pp. 203-5.

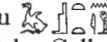
Sekhmetnefert , daughter of Khuikhnum , Prophet of Amūn, and Beketenēsi (?), alabaster, CG 4170, 4172-4. See id. ib. pp. 123-4, 124-6 (texts).



Thaiēsienimu , *sem*-priest, etc., son of Mutardais (mother), alabaster, CG 4311 (another, in Glahn Colln., see *infra*). Text, id. ib. p. 211.

Uzaḥorresnet , Prophet of Ḥa, Secretary, son of Tademeḥent , (mother), alabaster, CG 4122-5. Id. ib. pl. xvi (omitting CG 4124), pp. 84-5.

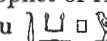

Others.

ʿAḥmosi, Prophet of Amūn Great-in-Victory (*wr-nḥt*), and of Khnum Lord of Ḥer-wēr, son of Teskapu , (mother), Late Period, in Frankfurt-am-Main, Liebieghaus, X. 11214.





Amenmosi (another in Cairo Mus. CG 4330, see *supra*), alabaster, formerly in Hoffmann Colln. Text, LEGRAIN, *Collection H. Hoffmann. Cat. des antiquités égyptiennes*, No. 76 with fig.

Ēsi(em)khebi , daughter of 'Arptah-ḥap  (probably mother), alabaster, Late Period, in Florence Mus. 2215-17. Texts, PELLEGRINI, *I Canopi* [etc.] in *Giornale della Società Asiatica italiana*, xi (1898), pp. 89-91 [25-7].

Ḥaremakhet , son of Kapespu (mother), sandstone, Dyn. XXVI, in Antwerp, Museum Vleeshuis, 79.1.153-6. See ALLEMANT, *Collection d'antiquités égyptiennes* [1878], Nos. 208-11; *A Catalogue . . . Collection of Egyptian Antiquities . . . Allemant*, Foster Sale Cat., London, May 9-10, 1878, No. 252; *Antwerp. Cat. de la Collection d'antiquités égyptiennes* (1881), p. 29 [153-6]; *Oudheidkundige Musea. Vleeshuis, Cat. viii, Egypte*, p. 53 [301-4].

Harkhebi , son of Tefnut  (mother), alabaster, Late Period, formerly in Passalacqua Colln., now in Berlin (East) Mus. 7170, 7174, 7180, 7183. Names, MÜLLER (I.) in *Festschrift Ägyptisches Museum Berlin* (1974), p. 190. See PASSALACQUA, *Cat. raisonné*, p. 74 [1409-12]; *Ausf. Verz.* pp. 276-7.

Ir'ahor , son of Pedehor, alabaster, Late Period, in Vatican Mus. Inv. 141-4. BOTTI and ROMANELLI, *Le Sculture del Museo Gregoriano Egizio*, Tav. xlvi [67-70], pp. 52-3. See MARUCCHI, *Il Museo Egizio Vaticano*, p. 75 [106-7], 76 [110-11].



Neferebrē-emakhet  , son of Psammethek-sineit  , both Commanders of the army, and Tadenubhotp , alabaster, temp. Psammetikhos II or later, formerly in Salt Colln., now in Brit. Mus. 36625-8. Texts, SHARPE, *Eg. Inscr.* 1 Ser. 114. See *Sotheby Sale Cat.* (SALT), June 29-July 8, 1835, No. 805 (repr. ATHANASI, *A Brief Account*); SHARPE, *Eg. Antiq.* p. 92; *Guide, 4th to 6th*, p. 38 [2].

Panehesi , Overseer of the Treasury of the Lord of the Two Lands, etc., alabaster, Ramesside, in Florence Mus. 2237. Text, PELLEGRINI, op. cit. pp. 84-5 [19]. Name and titles, SETHE, *Zur Geschichte der Einbalsamierung* [etc.] in *Sitzungsb. Berlin* (1934), p. 8* [XIII, D]. See MIGLIARINI, *Indication*, p. 52.



Para'emḥab (another two in Cairo Mus. CG 4322-3, see *supra*), alabaster, in New Haven (Conn.), Yale Univ. Art Gallery, 13.1.1953 (P.M. 6263).

Pedeamūn (another three in Cairo Mus. CG 4294-6, see *supra*), alabaster, in Alexandria, Graeco-Roman Mus. 1322. See BOTTI, *Notice des monuments* [etc.] (1893), p. 10 [722]; id. *Catalogue des monuments* [etc.], p. 421 [755].



Psammethek-*a(u)*neit , Commander of the army, Dyn. XXVI, formerly in Burton Colln., now in Durham, Univ. Gulbenkian Mus. N. 1986-9. Texts, WILKINSON MSS. xvii. C.9; BURTON MSS. 25655, 63. See *Sotheby Sale Cat.* (BURTON), July 25-7, 1836, No. 363; BIRCH, *Catalogue of the Collection of Egyptian Antiquities at Alnwick Castle*, pp. 328-30.

Psammethek-sineit  , Commander of the army, son of Neitemḥēt  (mother), alabaster, Dyn. XXVI, in Louvre, N.2975-8 (formerly Mimaut Colln.). DESROCHES-NOBLECOURT, *Les Religions égyptiennes* in *L'Histoire générale des religions*, fig. on p. 311 [lower]; LECA, *Médecine*, fig. 37; ARCHIVES phot. E. 683, 903. See DUBOIS, *Description des antiquités égyptiennes . . . Collection . . . Mimaut* (1837), No. 210 (cf. Nos. 298 and 425 for other monuments); BOREUX, *Guide*, ii, p. 567; VANDIER, *Guide* (1948), p. 75; (1952), p. 76; (1973), p. 143.



Psammethek-siptah (the other three in Cairo Mus. CG 4297-9, see *supra*), alabaster, in Manchester Mus. 11098.

Psammethek-sonb  , God's father, Head of craftsmen, alabaster, Dyn. XXVI. Two, formerly in J. Sams and J. Mayer Collns., now in Liverpool, Merseyside County Museums, M.11242, 11247; *Ancient Egypt. Objects . . . in the possession of J. Sams*

(1839), 20th pl. [middle and right]; M.11242, see GATTY, *Catalogue of the Mayer Collection*, Pt. 1 (1877), p. 38 [217]; (1879), p. 42 [217]. One, in Florence Mus. 2226; text, PELLEGRINI, op. cit. pp. 88-9 [24]; name and titles, BRUGSCH, *Thes.* 1446 [61]; see MIGLIARINI, *Indication*, p. 52.

Teti , Mayor of 'Anu , alabaster, Ramesside, formerly in Passalacqua Colln., now in Berlin (East) Mus. 7171, 7173. Name and title, SETHE, op. cit. p. 8* [XII, A]; MÜLLER (I.) in *Festschrift Ägyptisches Museum Berlin* (1974), p. 187. See PASSALACQUA, *Cat. raisonné*, p. 74 [two of 1413-16]; *Ausf. Verz.* p. 277.

Thaiēsienimu (another, in Cairo Mus. CG 4311, see *supra*), alabaster, in Glahn Colln. *Antik kunst i dansk privateje* (Udstilling i Ny Carlsberg Glyptotek, 16. maj-31. august 1974), No. 3 with fig.

Wehebrēc , son of 'Ankhemmatet  and Webekhnesioh , Dyn. XXVI, in Cincinnati (Ohio), Art Mus. 1947.397-400. [ADAMS], *Ancient Civilizations. Egypt, Greece, Rome* (The Cincinnati Art Museum) [1961], fig. 10; id. *Sculpture Collection of the Cincinnati Art Museum* (1970), figs. on p. 24.

Vessels.

Pottery vase of King 'Aḥa, in Michaelidis Colln. KAPLONY, *Inschriften, Suppl.* Taf. iv [1063], p. 32.

Ivory vase of Merytneit  (woman), Early Dynastic, in Michaelidis Colln. Id. ib. Taf. viii [1073], p. 34.

Alabaster fragment with cartouches of Ḥaremḥab, in Cairo Mus. CG 18790. VON BISSING, *Steingefässe (Cat. Caire)*, fig. on p. 172; HARI, *Horemheb*, fig. 78, p. 284 [32].

Alabaster jar, Pipuy  (woman) before Osiris, New Kingdom, in Cairo Mus. CG 18451. Text, VON BISSING, op. cit. p. 87, cf. Taf. v.

Palettes.

Amenmosi , (probably changed from Ra'mosi), Great scribe of the water in the Temple of Sethos I in the domain of Amūn, schist, temp. Sethos I or later, in Brit. Mus. 12778. GLANVILLE in *J.E.A.* xviii (1932), pl. viii [1], p. 58; WILKINSON MSS. iii. 9A. Text, BUDGE, *The Mummy* (1925), p. 174 [middle]; KITCHEN, *Ram. Inscr.* i. 332 [136]. See *Guide, Eg. Collns.* (1930), p. 58.

Ptaḥmosi , Governor of the town and Vizier, Greatest of the directors of craftsmen, etc., schist, temp. Tuthmosis III, in Louvre, N.3026. HAY MSS. 29848, 126. Text, PIERRET, *Rec. inscr.* i, pp. 93-4. BRUGSCH, *Thes.* 963 [lower]; GARDINER Notebook, 69, p. 2 (from HAY MSS.). See BOREUX, *Guide*, ii, p. 610; ANTHES in *Ä.Z.* 72 (1936), p. 63 [iv. 8a].

Name erased, Outline-draughtsman, wood, Dyn. XVIII, formerly in Burton Colln., now in Brit. Mus. 36825. GLANVILLE, op. cit. pl. viii [3], p. 61 (called Thebes); *Sotheby Sale Cat.* (BURTON), July 25-7, 1836, pl. i [viii], No. 229.

Tena , Scribe of the army of the Lord of the Two Lands, wood, Ramesside, in Berlin Mus. 8042. Text, *Aeg. Inscr.* ii, p. 304. See *Ausf. Verz.* pp. 216-17.

Cubit-measures.

Amenemōpet , Overseer of the Two Granaries of the Lord of the Two Lands in Upper and Lower Egypt, etc., wood, temp. Ḥaremḥab, in Turin Mus. Cat. 6347. LEPSIUS,

Die alt-ägyptische Elle und ihre Eintheilung (repr. from *Abhandlungen der Königl. Akademie der Wissenschaften zu Berlin*, 1865), Taf. i [b], p. 14 [1]; SAIGEY, *Traité de métrologie* [etc.] (1834), pl. 1 [1], pp. 9-12 (text incomplete); VALERIANI and SEGATO, *Atlante Monumentale* [etc.], i (1837), Tav. 37H [2]; SKINNER in SINGER [etc.], *A History of Technology*, i, fig. 566 [upper], p. 775 (text incomplete); SCHWALLER DE LUBICZ, *Le Temple de l'homme*, ii, pl. lxiv [A]; iii, p. 251; LORENZEN, *Technical Studies in Ancient Metrology* (1966), pl. at end; PETRIE ITAL. photos. 171 [3rd from top], 172 [middle], 173 [middle]. Text, HELCK, *Urk.* iv. 2173-4 [upper] [851], cf. *Übersetz.* (1961), p. 429. Names of divinities, LEPSIUS, *Über den ersten Ägyptischen Götterkreis* [etc.] in *Abhandlungen der Berliner Akademie der Wissenschaften*, 1851, Taf. i [iv] after p. 214. Cartouches, GAZZERA, *Descrizione dei Monumenti Egizi* [etc.] (1824), Tav. 12 [5], p. 55. See RODENBACH in *Rev. Arch.* n.s. xvii (1868), pp. 314-17; FABRETTI &c., *R. Mus. di Torino*, ii, p. 244.

Ptahmosi $\square \text{𓆎} \text{𓆏} \text{𓆐}$ (probably same as owner of palette Louvre N.3026, see *supra*), schist, temp. Tuthmosis III, in Leyden Mus. Inv.AD.54. LEPSIUS, *Die alt-ägyptische Elle und ihre Eintheilung* (repr. from *Abhandlungen der Königl. Akademie der Wissenschaften zu Berlin*, 1865), Taf. iii [c], pp. 15-16 [6], 57-8; LEEMANS, *Aeg. Mon.* ii, pl. ccxlviii [634]. See ANTHES in *Ä.Z.* 72 (1936), p. 63 [iv, 8b] (titles); LEEMANS, *Descr. rais.* p. 135 [I. 634].

Model boats.¹ Wood. Probably all early Middle Kingdom. In Cairo Mus.

Rowing-boat, CG 4913. REISNER, *Models of Ships and Boats (Cat. Caire)*, pl. xvii, pp. 69-70.

Three boats with deceased as mummy or seated under canopy, CG 4915-17. Id. ib. pls. xvii, xviii, pp. 70-4. CG 4916, PETRIE in *Anc. Eg.* (1914), fig. 20, pp. 24-5. See MASPERO, *Guide*, p. 324 [3240-2].

Other objects.

Obelisk of Hetepet $\frac{\text{𓆎}}{\text{𓆏}}$, Noblewoman of the King, Dyn. VI, in Cairo Mus. CG 17005. KUENTZ, *Obélisques (Cat. Caire)*, pl. iv, pp. 11-12.

Offering-stand of Hy $\text{𓆎} \text{𓆏}$, Prophetess of Hathor, etc., Dyn. V-VI, in Cairo Mus. CG 1296. BORCHARDT, *Denkmäler*, i, Bl. 1, p. 2.

Bronze shrine of Iyhetek $\text{𓆎} \text{𓆏} \text{𓆐}$, son of Penweben-tanakht(?) $\square \text{𓆎} \text{𓆏} \text{𓆐}$ and Setyersebu $\text{𓆎} \text{𓆏} \text{𓆐}$, Late Period, formerly in Abbott and N.Y. Hist. Soc. Collns., now in Brooklyn Mus. 37.1391E. WILKINSON MSS. xx. A. 4c [lower right]. See *N.Y.H.S. Cat.* p. 53 [840].

Gilded mummy-mask and cartonnage of Pedeharpekhrod, son of Psammethak, Ptolemaic, in Cairo Mus. Temp. No. 20.12.25.1. See MASPERO, *Guide*, p. 393 [3798].

Head-rest of Iti $\text{𓆎} \text{𓆏}$, Count, Overseer of tenants of the Great House, etc., alabaster, Dyn. VI, in Cairo Mus. CG 1792. BORCHARDT, *Denkmäler*, ii, Bl. 116, pp. 213-14.

Head-rest of Iyu $\text{𓆎} \text{𓆏} \text{𓆐}$, Door-keeper, Child of the nursery, wood, early Dyn. XVIII, formerly in N.Y. Hist. Soc. Colln., now in Brooklyn Mus. 37.440E. Text, JAMES, *Corpus*, i, pl. lii [207], p. 90. See *N.Y.H.S. Cat.* p. 31 [486].

Wooden fan-handle of Minnakht $\text{𓆎} \text{𓆏}$, Outline-draughtsman of the Temple of Rē, New Kingdom, in Cairo Mus. Temp. No. 6.4.23.12. VASSALLI MSS. 14. See MASPERO, *Guide*, p. 530 [5337].

¹ Possibly those on p. 673.

Cylinder seal of Userkaf, ivory, in Brit. Mus. 16774. HALL, *Catalogue of Egyptian Scarabs, etc., in the British Museum*, fig. on p. 261 [2597]; PETRIE, *Historical Scarabs*, No. 37; NEWBERRY, *Scarabs*, pl. v [8].

Two clay magical bricks with emplacements for Osiride statuettes, of Neferebrēc-sineit , with incised hieratic text, Dyn. XXVI. Text, ČERNÝ Notebook, 47, p. 77 verso.

Wooden stick of Ḥatiay , Scribe of the Two Granaries of the Temple of the Aten in Memphis, temp. Amenophis III or IV, in Leyden Mus. I.86. LEEMANS, *Aeg. Mon.* ii, pl. lxxxv [86]; HASSAN (A.), *Stöcke und Stäbe im Pharaonischen Ägypten*, p. 155 [43] with Taf. vi [3]. See LEEMANS, *Descr. rais.* p. 103.

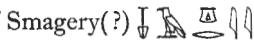
Mummy-cloth of . . . neferebrēc , son of Smagery(?)  (mother), with judgment scene, Dyn. XXVI. WILKINSON MSS. xvii. C.1.

Ptaḥemwia , Overseer of the Treasury of the Temple of a Million Years of Ramesses II in the domain of Amūn in Memphis, etc., on an unidentified object, temp. Ramesses II or later. Name and titles, MARIETTE, *Mon. div.* pl. 62 [c].

Piay , Scribe of the doors in the Temple of Neith Mistress of Sais, on an unidentified object, New Kingdom (or Dyn. XXVI). Name and title, id. ib. pl. 62 [e].

CONTENTS OF FASCICLE 2

PYRAMID-FIELD OF ŞAQQÂRA (continued)

II. NECROPOLIS (continued)

- C. East of the Step Pyramid
Old Kingdom, 575. Late Period, 586
- D. In the Step Pyramid Enclosure, 592.
- E. West of the Step Pyramid
Old Kingdom, 593. Late and Ptolemaic Periods, 612.
Finds, 613.
- F. Around the Pyramid-complex of Unis
Early Dynasty II, 613. Old and Middle Kingdoms, 614.
Late and Ptolemaic Periods, 648. Finds, 651.
- G. Between the Monastery of Apa Jeremias and the Enclosure of
Sekhemkhet
Old Kingdom, 653. New Kingdom, 654. Late Period, 669.
- H. Around Pyramids of Pepy I, Merenrē^c I, and Isesi, 671.
- I. Around Pyramids of Ibi and Pepy II and Mašabet Farašûn, 674.
- J. Tombs of position unknown
Old Kingdom, 689. Middle Kingdom, 700. New Kingdom, 701.
Late and Ptolemaic Periods, 718.
- K. Objects from tombs
Statues, 720. False-doors and stelae, 732. Blocks, etc., 749. Coffins
and sarcophagi, 763. Offering-tables and basins, 767. Pyramidia, 770.
Boxes, 770. Canopic-jars, 770. Vessels, 773. Palettes, 773. Cubit-
measures, 773. Model boats, 774. Other objects, 774.

III. Sacred Animal Complexes

Maps LXIX, LXX

Plan of Eastern and Western Groups, RHONÉ, *L'Égypte à petites journées* (1877), plan on p. 216; MARIETTE, *Sérapéum, Texte*, 1st plan at end; id. in *Bibl. Ég.* xviii, pl. ii; see WILCKEN, *Urkunden der Ptolemäerzeit*, i, pp. 9-12 with Abb. 2 (from MARIETTE).

A. EASTERN GROUP

('Greek Serapeum')

Map LXX

SMITH (H. S.) in *Glimpses of Ancient Egypt. Studies in Honour of H. W. Fairman*, pp. 164-5; MARIETTE, *Sérapéum, Texte*, pp. 72-5; RHONÉ, op. cit. pp. 255-8. Description of building containing colossal statue of Imhōtep, in Arabic MS. of 10th century, see STRICKER in *Acta Orientalia*, xix (1943), pp. 101-18.

NORTHERN ENCLOSURE. 'Es-Sign Yusuf.'

SMITH (H. S.) and JEFFREYS in *J.E.A.* 64 (1978), pp. 12-20, with plan, fig. 1.

Blocks. Ptolemy II Philadelphus; see SMITH (H. S.) in *Glimpses of Ancient Egypt. Studies in Honour of H. W. Fairman*, p. 164. Ptolemy V Epiphanes; (a) cornice, QUIBELL, *Saqqara* (1905-1906), pl. xxxi [5], p. 29; (b) heads of the King and Anubis, SMITH (H. S.) and JEFFREYS, op. cit. pl. v [3], p. 19.

Chapel of Bes. Ptolemaic.

QUIBELL, *Saqqara* (1905-1906), pp. 12-14; plan, on pl. iii.

Clay statue-groups of Bes with nude goddesses, and one with ape, and painted decoration on walls above and at sides, including bees on vine, Apis-bull, remains of soldier and a king slaying foe. One group, in Cairo Mus., id. ib. frontispiece, pl. xxvii, pp. 17, 28; MILNE Photo. Album, 2.9 [lower right]; others and paintings, QUIBELL, op. cit. pls. i, xxvi, xxviii, xxix, pp. 17, 28-9; Apis-bull, see KATER-SIBBES and VERMASEREN, *Apis, I*, p. 12 [32], cf. pl. xxiv (from QUIBELL).



Found in Northern Enclosure

Stela, Bes holding sword and snake, with small female figure, no text, Ptolemaic, formerly in von Bissing Colln. and The Hague, Scheurleer Mus., now in Amsterdam, Allard Pierson Mus. 7762. VON BISSING in *Mitteilungen des Deutschen archäologischen Instituts, Athenische Abteilung*, 1 (1925), Taf. v [2], p. 124 note 2; see *Allard Pierson Museum. Algemeene Gids* (1937), p. 10 [48].

JACKAL GALLERIES.

Position, DE MORGAN, *Carte de la Nécropole Memphite*, on pl. 10.

Coffins of jackals, wood, Ptolemaic or Roman, probably from here, in Cairo Mus. (a) Decorated and inscribed, CG 29765; MASPERO in *Ann. Serv.* iii (1902), pp. 283-5 with plate; GAILLARD and DARESSY, *La Faune momifiée de l'antique Égypte (Cat. Caire)*, pl. lv, pp. 129-30. (b) With decoration of barks and jackals, CG 29760; id. ib. pl. liv, pp. 127-8.

Fragments of false-doors of Sit-wernu  (presumably woman) and Sebkemkhent , 1st Int. Period, intrusive. CAIRO, CENTRE OF DOCUMENTATION photo. S.A., 2088. Names, GUNN Notebook, 21, p. 1.

B. WESTERN GROUP WITH THE SERAPEUM

Maps LXVIII, LXIX

AVENUE OF HUMAN-HEADED SPHINXES. Probably Nektanebos I.

MARIETTE, *Sérapéum, Texte*, pp. 7-10, 13-15, 75-6; id. *Choix de Monuments*, pp. 6-7; RHONÉ, *L'Égypte à petites journées* (1877), pp. 213-15, 218-19; WILCKEN, *Urkunden der Ptolemäerzeit*, i, pp. 7-8, 10. Notes of HARRIS (A. C.) mentioning Avenue of Sphinxes and identifying the Serapeum in 1847-8, SAYCE MSS. 18.

Sphinxes.

Two, in Berlin Mus. 7777-8 (latter in East). No. 7778 (probably), *Aeg. und Vorderasiat. Alterthümer*, Taf. 132; sketches, BORCHARDT in *Amiliche Berichte*, xxxix (1917-18), Abb. 35, col. 107. See *Ausf. Verz.* pp. 312-13.

Five, in Cairo Mus. CG 685, 1193-6; BORCHARDT, *Statuen*, iii, Bl. 126 (CG 685), p. 29; iv, Bl. 168 (CG 1193), pp. 95-6; CG 1193, HASSAN, *The Sphinx*, fig. 23 facing p. 110; id. *The Great Sphinx and its Secrets*, fig. 137, p. 197. Two heads, CG 1024-5; BORCHARDT, op. cit. iv, Bl. 160 (CG 1025), p. 30.

Six, in Louvre, N.391. One, DE MONTGON, *L'Égypte*, fig. on p. 115. See BOREUX, *Guide*, i, p. 168; VANDIER, *Guide* (1948 and 1952), p. 25; (1973), p. 57.

Twelve, in Vienna Mus. Inv.5756-67. See REINISCH, *Miramar* (1865), p. 230 [7-19]; *Uebersicht* (1895), p. 45 [II, IV, VI]; (1923), p. 18 [II, IV, VI].

Others, QUIBELL, *Saqqara (1905-1906)*, pl. xxiv [1], p. 27; LAUER in *Bull. Inst. Ég.* xxxiv (1951-2), fig. 2 on p. 210, cf. p. 207; id. *Saqqara*, pl. 1; id. and PICARD, *Les Statues ptolémaïques du Sarapieion de Memphis*, figs. 2, 13, cf. on pl. 1, p. 3; BINDER-HAGELSTANGE, *Ägypten. Ein Reiseführer* (1966), fig. on p. 346 [right].

EAST TEMPLE. Nektanebos II.

Plan LXVIII [2]

MARIETTE, *Sérapéum. Texte*, pp. 16-19, 23, 76-7, cf. pl. D on p. 26; LAUER and PICARD, op. cit. pp. 7-10, 25, with plan on pl. 26 (from drawing by Mariette).

(1) and (2) Two sphinxes of Nektanebos II, present location unknown.

See MARIETTE, op. cit. pp. 16-17 (as Nektanebos I); LAUER and PICARD, op. cit. pp. 7-8 note 1, 15 [3], 25. Base of one, in Louvre, N.424; BOREUX, *Guide*, i, pl. xxi [lower]; SCHARFF in *Miscellanea Gregoriana*, Abb. 2 [lower], p. 196.

(3) Statue of Onuris, sandstone, present location unknown.

See LAUER and PICARD, op. cit. p. 15 [1].

Found in Temple.

Jamb-fragment, heads of the King and Isis, in Louvre, N.402 [S.993]. VANDIER, *Guide* (1948), pl. vii [2], p. 25; (1952), pl. vii [2], p. 26; (1973), pl. vi [2], p. 57; DEVÉRIA squeezes, 6170C, 1, 1a-c. King, WOLF, *Kunst*, Abb. 689. See DE ROUGÉ, *Notice sommaire* (1876), p. 59; BOREUX, *Guide*, i, p. 175.

Block, upper part of the King before bull-headed Apis, in Louvre, N.423 [S.119]. See id. *ib.* i, pp. 174-5.

Statue of Bes, Dyn. XXX, in Louvre, N.437. *Id. ib.* i, pl. xix, p. 168; GALVANO, *L'Arte egiziana antica*, fig. 60; RANKE, *The Art of Ancient Egypt*, and BREASTED, *Geschichte Aegyptens* (1936), 177; DESROCHES, *L'Art égyptien au Musée du Louvre* (1941), fig. on 29th p. [lower]; LAUER, *Saqqara*, pl. 6; *id.* and PICARD, *op. cit.* fig. 5, p. 9; *Egyptian Mythology*, fig. on p. 113; MICHALOWSKI, *Art*, fig. 620; ARCHIVES phot. E.63; MARBURG INST. photo. 48797. See MARIETTE, *op. cit.* p. 17; VANDIER, *Guide* (1948), p. 25; (1952), p. 26; (1973), p. 57.

Perhaps from here.

Stela, Nektanebos II kneeling before Apis-bull, year 2, quartzite, found reused in Monastery of Apa Jeremias, in Cairo Mus. Temp. No. 2.12.24.3. SPIEGELBERG in QUIBELL, *Saqqara (1907-1908)*, pl. lii, pp. 10, 89-93, 112; text, DARESSY in *Ann. Serv.* ix (1908), pp. 154-6; see KATER-SIBBES and VERMASEREN, *Apis, I*, p. 24 [85] (as Nektanebos I).

Block with cartouches of Nektanebos I, in Louvre, B 33. See DE ROUGÉ, *Notice des monuments* (1883), p. 62.

Found near Hemicycle with Hellenistic Statues, etc.

Blocks from pillars or jambs of Ramesses II. See LAUER and PICARD, *op. cit.* p. 23.

Statuette of Apis-bull, schist, Late Period or Ptolemaic, in Cairo Mus. JE 89607. LAUER in *Ann. Serv.* liv (1957), pl. iv, pp. 111-12; see KATER-SIBBES and VERMASEREN, *Apis, I*, p. 11 [28], cf. pl. xxii (from LAUER).

Upper part of statuette of a Queen or Isis, schist, Ptolemaic. EL-KHOULY in *J.E.A.* 59 (1973), pl. xli [2], p. 155.

APPROACH TO SERAPEUM ENCLOSURE. 'Dromos' of Mariette.

Plan LXVIII [2]

Plan, LAUER and PICARD, *Les Statues ptolémaïques du Sarapieion de Memphis*, on pl. 26 (from drawing by Mariette); view, on pls. 2 [a], 18; LAUER, *Saqqara*, pl. 2. See MARIETTE, *Sérapéum, Texte*, pp. 77-8.

(4) Lion-statue, Dyn. XXX, in Louvre, N.432a [A.F.2962; S.1091].

MARIETTE, *Sérapéum, Atlas*, pl. 4 [d], *Texte*, p. 29; LAUER, *Saqqara*, pl. 7; *id.* and PICARD, *op. cit.* fig. 6, pp. 11, 16 [6], 18-19; DE MONTGON, *L'Égypte*, fig. on p. 94; DESROCHES, *L'Art égyptien au Musée du Louvre* (1941), fig. on 30th p. [lower]; ARCHIVES phot. E.992. See ROEDER in *Miscellanea Gregoriana*, pp. 185-6, 188-9; BOREUX, *Guide*, i, p. 174; VANDIER, *Guide* (1948 and 1952), p. 15.

(5) Statue of Horus as hawk, probably Late Period or Ptolemaic, now destroyed except for base.

See MARIETTE, *Sérapéum, Texte*, p. 29; LAUER and PICARD, *op. cit.* pp. 16 [11], 17.

(6) Two sphinxes of Merneptah, sandstone, one (headless) in Louvre, IM.223 [N.393], the other destroyed.

Louvre sphinx, ARCHIVES phot. E.623. See MARIETTE, *Sérapéum, Texte*, p. 29; LAUER and PICARD, *op. cit.* pp. 16 [15], 18, 23-4; BOREUX, *Guide*, i, p. 170.

(7) Lion-statue, Late Period or Ptolemaic, now displaced.

MARIETTE, *Sérapéum, Atlas*, pl. 5 [a]. Two similar lion-statues, see LAUER and PICARD, *op. cit.* pp. 16 [17], 18, with figs. 11 (from MARIETTE), 12 (one).

Chapel of Apis.

Statue of Apis-bull, Dyn. XXX, in Louvre, N.390 [S.98]. MARIETTE, *Sérapéum, Atlas*, pl. 3 [a]; *Texte*, p. 29; BOREUX, *Guide*, i, pl. xx, pp. 168-9; GALVANO, *L'Arte egiziana antica*, fig. 59; DESROCHES, op. cit. fig. on 30th p. [upper]; DE MONTGON, *L'Égypte*, fig. on p. 112; VANDIER and SOUGEZ, *La Sculpture égyptienne au Musée du Louvre*, 27th pl. [lower]; LAUER, *Saqqara*, pl. 10; id. and PICARD, op. cit. figs. 8, 9, pp. 14, 16 [14], 19; MONTET, *Eternal Egypt*, pl. 69; KATER-SIBBES and VERMASEREN, *Apis, I*, p. 5 [1] with pls. i, ii; ARCHIVES phot. E.73. See DE ROUGÉ, *Notice sommaire* (1876), pp. 57-8; VANDIER, *Guide* (1948 and 1952), p. 14; (1973), p. 57.

SERAPEUM ENCLOSURE WITH TOMBS OF APIS-BULLS

Plans LXVIII [2] and [3]

PYLON. Nektanebos I.

Cornice-blocks with name of the King. See MARIETTE, *Sérapéum, Texte*, p. 27 (as Nektanebos II).

(8) Two lion-statues, in Louvre, N.432b, c [A.F.2963-4; S.971-2].

N.432b [A.F.2963; S.971], BOREUX, *Guide*, i, pl. xxi [upper], p. 169; SCHARFF in *Miscellanea Gregoriana*, Abb. 2 [upper], p. 196; *L'Égypte des Pharaons* (Marcq-en-Baroeul, Oct. 1977-Jan. 1978), No. 1 with fig. (as N.432c); ARCHIVES phot. E.606. See ROEDER in *Miscellanea Gregoriana*, pp. 185-6, 188-9; DE ROUGÉ, *Notice sommaire* (1876), p. 58; VANDIER, *Guide* (1948 and 1952), p. 23; (1973), p. 46.

Donation-stela of Nektanebos I to Khons, originally set in pedestal of one of lion-statues, in Louvre, C 318 [IM.131]. See MARIETTE, *Sérapéum, Texte*, p. 27; VANDIER, *Guide* (1948 and 1952), p. 17; (1973), p. 27.

ISOLATED TOMBS

Plan LXVIII [3]

Plan showing position, RHONÉ, *L'Égypte à petites journées* (1877), on pl. facing p. 228; MALININE [etc.], *Cat.* i, on pl. facing p. xvi. Section of a tomb, MARIETTE, *Sérapéum, Texte*, fig. 1 on p. 117 = id. *Renseignements* (1855), fig. 1 on p. 47 (repr. in *Bibl. Ég.* xviii, fig. 1 on p. 138); MASPERO, *L'Arch. ég.* (1887), fig. 145; (1907), fig. 151.

APIS I [I OF DYN. XVIII] of Mariette. Temp. Amenophis III.

Tomb C1 of Rhoné, A of Mariette.

Chapel. Above burial chamber.

Amenophis III and son D̄hutmosi before Apis-bull. Texts, MARIETTE, *Sérapéum, Texte*, pp. 124-5 = id. *Renseignements* (1855), p. 53 (repr. in *Bibl. Ég.* xviii, p. 149).

Burial chamber.

Four canopic-jars and inscribed block. Id. *Sérapéum*, pl. 1.

Four magical bricks, found in niches, in Louvre, IM.5336-9 [N.842]. MONNET in *Rev. d'Ég.* 8 (1951), pls. 8, 9, 10 [B, C], pp. 153 with note 3, 155-60 [2].

Monuments of D̥hutmosi. In Louvre.

Vase of [D̥hutmosi], alabaster, N.482. Name and title, GAUTHIER, *Livre des Rois*, ii, p. 336 [ciii, B.3]. See PIERRET, *Cat.* No. 364.

Four vases, pottery, N.455, 484. See id. ib. No. 365.

APIS II [V OF DYN. XVIII] of Mariette. Probably Dyn. XVIII.

Tomb C2 of Rhoné, B of Mariette.

Four canopic-jars, in Louvre, S.1164-7. MARIETTE, *Sérapéum*, pl. 5; one, WILKINSON MSS. xxiv. 5 [middle].

Stelae. In Louvre.

May , Servant of Amūn and Apis, two registers, **I**, hawk-headed Horus and deified King Teti(?) before Osiris, with Isis and Nephthys beyond, **II**, May adoring Apis-bull, IM.5305 [E.3012; A.F.125; S.1168]. MALININE [etc.], *Cat.* i, pl. i [1], pp. 1-2; MARIETTE, *Sérapéum*, pls. 6, 7 [1, 2]. Cartouche, id. *Sérapéum, Texte*, fig. 7, pp. 131-5 = id. *Renseignements* (1855), fig. 7, pp. 56-7 (repr. in *Bibl. Ég.* xviii, fig. 7, pp. 158-64); GAUTHIER, *Livre des Rois*, iii, p. 148 [ii]; DEVÉRIA squeezes, 6166, i. 82. See PIERRET, *Cat.* No. 274.

Two registers, **I**, Apis-bull and Osiris, **II**, two men (no names) kneeling adoring before offerings, IM.5306 [S.1170; No. 2]. MALININE [etc.], *Cat.* i, pl. i [2], pp. 2-3. Texts, CHASSINAT in *Rec. Trav.* xxi (1899), p. 70 [xxxiii]. See REVILLOUT, *Cat.* No. 386.

Two registers, **I**, Apis-bull and Osiris seated, **II**, two men (no names) kneeling adoring, IM.5307 [S.1169; No. 1]. MALININE [etc.], *Cat.* i, pl. i [3], p. 3. See REVILLOUT, *Cat.* No. 385.

APIS III [II OF DYN. XVIII] of Mariette. Temp. Tutankhamūn.

Tomb C3 of Rhoné, C of Mariette.

Four canopic-jars, in Louvre, S.1151-4. MARIETTE, *Sérapéum*, on pl. 2; three, GOODWIN MSS. 31279, 25-7; one, DESROCHES, *L'Art égyptien au Musée du Louvre* (1941), fig. on 24th p. [middle]; text of another, WILKINSON MSS. xxiv. 5 [right]. Lid of one, BÉNÉDITE in *Mon. Piot*, xxiv (1921), fig. 10, p. 65. See DE ROUGÉ, *Notice sommaire* (1876), p. 59; BOREUX, *Guide*, i, p. 170.

Three glass pendants with name of Tutankhamūn, in Louvre, No. 456. One, MARIETTE, *Sérapéum*, on pl. 2; PETRIE, *History*, ii (1924), fig. 150, pp. 235, 237; MICHAÏLIDIS in *Ann. Serv.* xlv (1947), fig. 16, p. 125. Text, MARIETTE, *Sérapéum, Texte*, fig. 4, pp. 125-6 = id. *Renseignements* (1855), fig. 4, p. 53 (repr. in *Bibl. Ég.* xviii, fig. 4, p. 150); HELCK, *Urk.* iv. 2062 [785], cf. *Übersetz.* (1961), p. 382. See BOREUX, *Guide*, ii, p. 546 [bottom].

APIS IV AND V [III AND IV OF DYN. XVIII] of Mariette. Temp. Haremḥab.

Tombs C4 and C5 of Rhoné, D and E of Mariette.

See MARIETTE, *Sérapéum, Texte*, pp. 66-7.

Block with name of the King, from débris of chapel. See id. ib. p. 126 = id. *Renseignements* (1855), p. 53 (repr. in *Bibl. Ég.* xviii, p. 151).

First Room. Apis IV. Painted decoration.

Apis-bull, four Sons of Horus, Anubis, Isis, and Nephthys; MARIETTE, *Sérapéum*, pl. 3.

Second Room. Apis V.

Canopic-jars, in Louvre, S.1160-3. Id. ib. pl. 4 [2-6]. See BOREUX, *Guide*, i, p. 170; VANDIER, *Guide* (1948 and 1952), p. 6; (1973), p. 56.

Text of coffin, MARIETTE, *Sérapéum, Texte*, p. 129 = id. *Renseignements*, p. 55 (repr. in *Bibl. Ég.* xviii, p. 156).

APIS VI [I OF DYN. XIX] of Mariette. Temp. Sethos I.

Tomb C6 of Rhoné, F of Mariette.

Block with name of the King, from débris of chapel. See MARIETTE, *Sérapéum, Texte*, p. 137 = id. *Renseignements* (1855), p. 66.

APIS VII AND IX [II AND IV OF DYN. XIX] of Mariette. Years 16 and 30 of Ramesses II.¹

Tomb C8 of Rhoné, G of Mariette.

MARIETTE, *Sérapéum, Texte*, pp. 62-4, 137-42; id. *Renseignements* (1855), pp. 66-8.

South wall with painted decoration. Double-scene, Ramesses II with son Kha'emwëset censuring and libating before bull-headed Apis, with four Sons of Horus behind; id. *Sérapéum*, pl. 8; left half, BRUGSCH, *Recueil*, pl. viii [1]; texts, KITCHEN, *Ram. Inscr.* ii. 367 [131, A].

 Finds.

Canopic-jar dedicated by Kha'emwëset, in Louvre (unnumbered). MARIETTE, *Sérapéum*, pl. 10 [upper middle]; text, KITCHEN, op. cit. 368 [131, D]; see MARIETTE, *Sérapéum, Texte*, pp. 61-2, 138; id. *Renseignements* (1855), p. 66; GOMAA, *Chaemwese* [etc.], pp. 78-9 [22], cf. Abb. 8.

Two magical bricks, in Louvre, IM.3597-8 [N.842]. MONNET in *Rev. d'Ég.* 8 (1951), pls. 10 [A], 11, pp. 154, 156-8 [6]; texts, KITCHEN, op. cit. 368 [131, C].

Pectoral² with name of Ramesses II, gold inlaid with glass, in Louvre, IM.2886 [N.767; E.79]. MARIETTE, *Sérapéum*, pl. 9; SCHUMANN-ANTELME in *Göttinger Miszellen*, No. 21 (1976), pp. 77-82 with figs.; *recto*, RHONÉ, *L'Égypte à petites journées* (1877), pl. facing p. 229 [middle]; PERROT and CHIPIEZ, *Hist. de l'Art*, i, fig. 566; DEVILLE, *Histoire de l'art de la verrerie dans l'antiquité* (1873), pl. cx [A]; MASPERO, *Hist. anc.* ii, fig. on p. 492; id. *Eg. Art*, pl. facing p. 148 [upper], cf. pp. 148-50; id. *Essais*, fig. 56, pp. 183-5; id. *Égypte*, fig. 408; WHYTE in *P.S.B.A.* xv (1893), pl. i facing p. 408, cf. p. 411; VERNIER, *La Bijouterie et la joaillerie égyptiennes*, pl. vii [1]; BÉNÉDITE, *L'Art égyptien dans ses lignes générales*, pl. xxxiv, p. 72; CAPART, *L'Art ég.* iv, pl. 750 [lower]; PETRIE, *Arts and Crafts*, fig. 105 facing p. 94; BOREUX, *L'Art ég.* pl. lxiii [D, middle]; id. *Guide*, ii, pl. xlvi [lower], p. 350; DESROCHES, *L'Art égyptien au Musée du Louvre* (1941), fig. on 25th p. [bottom]; DESROCHES-NOBLECOURT, *Le Style égyptien*, pl. liii [upper], p. 160; id. *L'Art ég.* fig. 73 [top]; id. and DU BOURGUET, *L'Art égyptien*, pl. xxxi; DAUMAS, *Civ. de l'Ég.* pl. 219; CHARBONNEAUX, *Les Merveilles du Louvre*, i, pl. on p. 79 [upper]; WOLDERING, *Ägypten. Die Kunst der Pharaonen*, pl. on p. 185 (reversed); id. *Götter*, fig. on p. 248 [Kat. 102]; KAYSER, *Ägyptisches Kunsthandwerk*, Abb. 202; MICHALOWSKI, *Art*, fig. 796; WILKINSON (A.), *Ancient Egyptian Jewellery*, pl. lxi [A]; FEUCHT-PUTZ, *Die königlichen Pektoreale*, Taf. x [24], p. 172; ALDRED, *Jewels of the Pharaohs*, pl. 145; LAUER, *Saqqara*, pl. 14; VANDIER, *Guide* (1973), pl. xii [1], p. 92; ARCHIVES phot.

¹ From stela of Piay, in Louvre, IM.4963, see *infra*. Year 25 refers to the death of a Mnevis-bull.

² Selected references.



E.337. Name, KITCHEN, *Ram. Inscr.* ii. 366 [130, A (ii)]. See DE ROUGÉ, *Notice sommaire* (1876), p. 73; PIERRET, *Cat.* No. 521; VANDIER, *Guide* (1948), p. 48 [middle], cf. pl. xi [upper]; (1952), p. 49 [middle], cf. pl. xi [upper].

Jewellery dedicated by Paser, Vizier (Theb. tb. 106), in Louvre. (a) Pectoral, IM.2894 [N.762; E.68]; MARIETTE, *Sérapéum*, pl. 12 [middle]; BOREUX, *Guide*, ii, pl. xlvii [upper left], p. 350; id. *L'Art ég.* pl. lxiii [D, right]; DAUMAS, *Civ. de l'Ég.* pl. 226; ARCHIVES phot. E.337; texts, KITCHEN, op. cit. 366-7 [130, B (ii)]; see PIERRET, *Cat.* No. 524; FEUCHT, *Pektorale nichtköniglicher Personen*, pp. 65-6 [11 B], 70 [29]. (b) Colonnade, N.760 [E.69]; BOREUX, *Guide*, ii, pl. xlvi [middle], p. 342; ARCHIVES phot. E.722; see PIERRET, *Cat.* No. 522. Both, see DE ROUGÉ, *Notice sommaire* (1876), p. 74; VANDIER, *Guide* (1948), p. 48; (1952), p. 49.



Stelae. Temp. Ramesses II. In Louvre.

Amenemḥab , Head of outline-draughtsmen of the ḥarīm at Memphis, before bull-headed Apis, probably from here, IM.5954 [No. 11]. MALININE [etc.], *Cat.* i, pl. vi [17], p. 16; see REVILLOUT, *Cat.* No. 395.



Amenmosi, Overseer of the royal apartments of the ḥarīm at Memphis, two registers, I, before Osiris and Isis, II, before Apis-bull, IM.5268 [S.1466; No. 6]. MALININE [etc.], *Cat.* i, pl. iv [10], pp. 10-11; text, CHASSINAT in *Rec. Trav.* xxi (1899), p. 73 [xxxvi]; KITCHEN, *Ram. Inscr.* ii. 374 [132, H]; see REVILLOUT, *Cat.* No. 390.

Dḥutemḥab , Royal scribe, Overseer of the royal apartments of the ḥarīm at Memphis, two registers, I, kneeling adoring bull-headed Apis, II, Ḥori , Deputy in Memphis, kneeling adoring bull-headed Apis, probably from here, IM.5952 [No. 10]. MALININE [etc.], *Cat.* i, pl. vi [15], p. 15; MARIETTE, *Sérapéum*, pl. 17 [right]; see REVILLOUT, *Cat.* No. 394.



Ipy , Scribe of the Temple of Ptah, IM.5271 [S.1465; No. 12]. MALININE [etc.], *Cat.* i, pl. iv [13], p. 13; text, KITCHEN, op. cit. 375 [132, K]; see REVILLOUT, *Cat.* No. 396.

Khons , Head of the *shaytiu*, two registers, I, Khons, wife Nezet  and daughter before Apis-bull in shrine, II, family before Osiris seated, IM.4964 [No. 13]. MALININE [etc.], *Cat.* i, pl. iii [7], pp. 7-8; MARIETTE, *Sérapéum*, pl. 17 [left]; text, KITCHEN, op. cit. 373 [132, F]; names and titles, LIEBLEIN, *Dict.* No. 965; see REVILLOUT, *Cat.* No. 397.

Merihu , Retainer of His Majesty, two registers, I, before Apis-bull and Osiris, II, family, fragmentary, S.N.81 [No. 16]. MARIETTE, *Sérapéum*, pl. 17 [middle]; omitting top, MALININE [etc.], *Cat.* i, pl. iv [11], pp. 11-12; text, KITCHEN, op. cit. 374 [132, I]; see REVILLOUT, *Cat.* No. 400.

Neḥeḥ-endisu , Head of the store-room of Ptah, two registers, I, Neḥeḥ-endisu and wife before bull-headed Apis, II, Neḥeḥ-endisu and Neferronpet  with oryx before Osiris, fragmentary, IM.5270 [No. 14]. MALININE [etc.], *Cat.* i, pl. v [12], pp. 12-13; MARIETTE, *Sérapéum*, pl. 18 [middle]; text, KITCHEN, op. cit. 374-5 [132, J]; see REVILLOUT, *Cat.* No. 398.

Piay , Royal scribe, Overseer of embalmers in the two embalming houses, etc. (a) Apis-bull (died in year 16) and Mnevis-bull (died in year 25), and two registers below, I, Piay and Dḥutmosi Raḥmosi, Chief lector-priest in the embalming house, etc., before Apis-bull with statue in shrine, II, text and two men, year 30, IM.4963 [N.411; S.1457; No. 3]. MALININE [etc.], *Cat.* i, pl. ii [4], pp. 3-5; MARIETTE, *Sérapéum*, pl. 15; upper part, VAN DER LEEUW, *De Godsdienst van het oude Aegypte*, pl. 63 facing p. 112; text, BRUGSCH, *Thes.* 964-6 (as IM.4969); CHASSINAT in *Rec. Trav.* xxi (1899), pp. 70-2 [xxxiv]; KITCHEN, *Ram.*

Inscr. ii. 369–70 [132, A]; date and some names and titles, LIEBLEIN, *Dict.* No. 899 (as No. 2); see MARIETTE, *Sérapéum, Texte*, p. 142 (part of text) = id. *Renseignements* (1855), p. 68; DE ROUGÉ, *Notice sommaire* (1876), p. 59 (as S.1553); REVILLOUT, *Cat.* No. 387. (b) Two registers, I, Piay and Riya , Embalmer in the embalming house, etc., before Apis-bull in shrine, II, text and Riya and another man, year 30, IM.5936 [No. 5 (as No. 4 in 1st ed. in error)]; MALININE [etc.], *Cat.* i, pl. ii [5], pp. 5–6; MARIETTE, *Sérapéum*, pl. 16; I, PRISSE, *L'Art ég. Texte*, fig. on p. 25; text, CHASSINAT, op. cit. xxi (1899), pp. 72–3 [xxxv]; KITCHEN, op. cit. 370–1 [132, B]; names, titles, and date, LIEBLEIN, *Dict.* No. 898 (as No. 1); see REVILLOUT, *Cat.* No. 389. (c) Piay and Yy , Embalmer in the embalming house, etc., before Apis-bull in shrine, fragments, S.N.84 [No. 4]; MALININE [etc.], *Cat.* i, pl. i [6], pp. 6–7; text, KITCHEN, op. cit. 371–2 [132, C]; see REVILLOUT, *Cat.* No. 388.

Ptaḥmosi, Royal scribe, Steward, three registers, I, Ptaḥmosi and wife Yuhebet  before Ptaḥ seated, II, man and wife before Apis-bull, III, people, IM.5269 [No. 9]. MALININE [etc.], *Cat.* i, pl. iii [9], pp. 9–10; MARIETTE, *Sérapéum*, pl. 18 [left]; text, KITCHEN, op. cit. 372–3 [132, E, II]; names and titles of Ptaḥmosi and wife, LIEBLEIN, *Dict.* No. 964; see REVILLOUT, *Cat.* No. 393.

Sekhmetnefert , Mourner of Apis (woman), two registers, I, before Apis-bull, II, people before Osiris seated, IM.6153 [No. 8]. MALININE [etc.], *Cat.* i, pl. iv [8], pp. 8–9; MARIETTE, *Sérapéum*, pl. 18 [right]; text, KITCHEN, op. cit. 373 [132, G]; see REVILLOUT, *Cat.* No. 392.

Thaia , Head of workmen of the Necropolis of the ḥarîm at Memphis, before bull-headed Apis, probably from here, IM.5953 [No. 7]. MALININE [etc.], *Cat.* i, pl. vi [16], pp. 15–16; text, CHASSINAT in *Rec. Trav.* xxi (1899), p. 73 [xxxvii]; see REVILLOUT, *Cat.* No. 391.

GALLERIES

Plan, RHONÉ, *L'Égypte à petites journées* (1877), on pl. facing p. 228; MALININE [etc.], *Cat.* i, on pl. facing p. xvi; part, MARIETTE, *Sérapéum, Texte*, pl. F on p. 43.

'LESSER VAULTS'.



Plan LXVIII [3]

See MARIETTE, *Sérapéum, Texte*, pp. 56–60, 80. Plan of north part, VERCOUTTER in *Kush*, viii (1960), fig. 1, p. 66 note 30.

APIS X–XIV [V–IX OF DYN. XIX] of Mariette. Temp. Ramesses II.

Chambers I, J, K of Mariette, D, D' of Rhoné.

MARIETTE, *Sérapéum, Texte*, pp. 142–3, 145–6, mentioning date 'year 55' on wall of one chamber (presumably K of Mariette); id. *Renseignements* (1855), pp. 85, 86 (repr. in *Bibl. Ég.* xviii, pp. 167, 171–2).

Stela, Merneptah (son of Ramesses II, later King), two registers, I, before Apis-bull, II, Thay  To , Scribe of the Hereditary prince, and father Smentai , Retainer of the Hereditary prince, in Louvre, IM.3747 [N.412; S.1555; No. 15]. MALININE [etc.], *Cat.* i, pl. v [14], p. 14; MARIETTE, *Sérapéum*, pl. 21 (as Apis X); DEVÉRIA squeezes, 6166, ii. 132. Text, KITCHEN, *Ram. Inscr.* ii. 377 [B (ii)]. See DE ROUGÉ, *Notice sommaire* (1876), p. 60; REVILLOUT, *Cat.* No. 399; CHRISTOPHE in *Ann. Serv.* li (1951), p. 343 note 1.

APIS XVI [II OF DYN. XX] of Mariette. Temp. Ramesses VI.

MARIETTE, *Sérapéum, Texte*, p. 147 = id. *Renseignements* (1855), p. 87 (repr. in *Bibl. Ég.* xviii, pp. 173-4).

Jar dedicated by Ramesses VI, in Louvre, N.5415. Id. *Sérapéum*, pl. 22 [3]; see PIERRET, *Cat.* No. 379; VANDIER, *Guide* (1973), p. 99.

APIS XVII [III OF DYN. XX] of Mariette. Temp. Ramesses IX.

Chamber M of Mariette, E' of Rhoné.

Cylindrical jars, (a) small, Ramesses IX, (b) large, Ramesses-Siptah, both in Louvre, N.442. MARIETTE, *Sérapéum*, pl. 22 [5, 7] (latter as Apis IV); cartouches, id. *Sérapéum, Texte*, p. 148 = id. *Renseignements* (1855), p. 87 (repr. in *Bibl. Ég.* xviii, p. 174); see PIERRET, *Cat.* Nos. 375-6; BOREUX, *Guide*, ii, p. 528; VANDIER, *Guide* (1973), p. 99. (b) Id. in *Rev. d'Ég.* 23 (1971), fig. 4, p. 189.

Vase of Ramesses-Siptah, in Louvre, N.5418. Id. ib. fig. 5, pp. 189-91; MARIETTE, *Sérapéum*, pl. 22 [6] (as Apis IV); see PIERRET, *Cat.* No. 374; VANDIER, *Guide* (1973), p. 99.

Faïence *zad*-amulet of Ramesses IX, in Louvre, N.5416. MARIETTE, *Sérapéum*, pl. 22 [4]; ARCHIVES phot. E.1064; see BOREUX, *Guide*, ii, p. 526; VANDIER, *Guide* (1973), p. 99.







APIS XXVII [I OF DYN. XXII] of Mariette. Year 23 of Osorkon II.

MARIETTE, *Sérapéum, Texte*, pp. 158-9 = id. *Renseignements* (1855), pp. 93-4 (repr. in *Bibl. Ég.* xviii, pp. 188-91).

Stela with date, two men (one of them Amenemōpet, Royal scribe, etc.) before bull-headed Apis seated, painted, much effaced, in Louvre, IM.3090 [N.5419; S.1883]. MALININE [etc.], *Cat.* i, pl. vi [18], p. 17; see PIERRET, *Cat.* No. 275.

Statues.

Block-stature of Huy  Chief Governor of Memphis, temp. Ramesses II, in Louvre, N.519. MARIETTE, *Sérapéum*, pl. 23; ARCHIVES phot. E.899; see PIERRET, *Cat.* No. 27; VANDIER, *Guide* (1973), p. 125.

Sheshonk       Ptah-Sokari-Osiris, in Budapest, Szépművészeti Múzeum, 51.2050. OROSZLÁN and DOBROVITS, *Az Egyiptomi Gyűjtemény* (1939), pl. 1, pp. 21-2 [32] (text); VARGA and WESSETZKY, *Egyiptomi kiállítás. Vezető* (1955), pl. vii, p. 17; (1961), pl. xix, p. 26; (1964), pl. xiii, p. 25; id. *Az ókori Egyiptom* (1970), pl. 22; VARGA in *Bull. Soc. fr. d'Ég.* 36 (June 1963), fig. on p. 27 [right], cf. p. 29; id. *Egyiptomi kiállítás. Vezető* (1976), pl. 26. Titles, BUDGE, *The Kings of Egypt*, ii, p. 48 [bottom]; DARESSY in *Rec. Trav.* xxxv (1913), p. 142 [bottom]; BRUGSCH, *Thes.* 1450 [79].

APIS XXVIII [II OF DYN. XXII] of Mariette. Year 14 of Takelothis II.

MARIETTE, *Sérapéum, Texte*, p. 159 = id. *Renseignements* (1855), p. 94 (repr. in *Bibl. Ég.* xviii, p. 191).



Block of Merneptah, Greatest of the Directors of craftsmen of Ptah, with cartouches of Takelothis II, in Louvre, S.N.82 [No. 119]. MALININE [etc.], *Cat.* i, pl. vii [19], p. 18; cartouches, GAUTHIER, *Livre des Rois*, iii, p. 354 [xii].



Lower part of stela, name lost, year 14, perhaps from here, in Alexandria, Graeco-Roman Mus. Text, DARESSY in *Ann. Serv.* v (1904), p. 121 [xxiv]; see BOTTI, *Catalogue des monuments* [etc.], p. 353 [22].

Stela of Zepthef'ankh, Servant of Hathor Mistress of the Southern Sycamore, inscribed in ink, much effaced, probably temp. Takelothis II and from here, in Louvre, IM.2810 [S.1890; No. 21]. MALININE [etc.], *Cat.* i, pl. vii [20], pp. 18-19.

APIS XXIX [III OF DYN. XXII] of Mariette. Year 28 of Sesonchis III.

Chamber P of Mariette, F of Rhoné.



Stela, Pedēsi, son of Thekerti , both Great chiefs of the Ma, and Thesubastepert , with two other men before bull-headed Apis, year 28 of Sesonchis III, in Louvre, IM.3749 [N.413; S.1898; No. 18]. MARIETTE, *Sérapéum*, pl. 24; MALININE [etc.], *Cat.* i, pl. vii [21], pp. 19-20; SCHMIDT, *Levende og Døde*, fig. 887; DEVÉRIA squeezes, 6169, i. 39; WILKINSON MSS. xxiv. 19 [1]. Text, CHASSINAT in *Rec. Trav.* xxii (1900), pp. 9-10 [xxxviii]. Names and titles, LIEBLEIN, *Dict.* No. 1011; id. in *Rev. Arch.* n.s. xviii (1868), p. 283; LEGRAIN in *Rec. Trav.* xxix (1907), pp. 178-9. See MARIETTE, *Sérapéum*, *Texte*, pp. 159-60; YOYOTTE in *Mélanges Maspero*, i [4], p. 124 [3]; DE ROUGÉ, *Notice sommaire* (1876), p. 60; REVILLOUT, *Cat.* No. 401.

Statue-group, two men (unfinished) kneeling supporting stela of Esptaḥ, God's father of Ptaḥ, Prophet of the Temple of Mut foremost of 'Abuy-neteru , son (more likely descendant) of Shedsunefertem , Greatest of the Directors of craftsmen, etc., in Louvre, N.436. VANDIER in *J.E.A.* 35 (1949), pl. xiv, pp. 135-8; stela, MARIETTE, *Sérapéum*, pl. 25 [1].

APIS XXX [IV OF DYN. XXII] of Mariette. Year 2 of Pemu.



Dated stelae. In Louvre. See DE ROUGÉ, *Notice sommaire* (1876), p. 60.

Pedēsi (same as dedicator of stela IM.3749, see *supra*) and son Harsiēsi before bull-headed Apis and Western goddess, giving the date of birth of the Apis-bull as year 28 of Sesonchis III, two stelae, IM.3697, 3736 [S.1904-5; Nos. 34, 36]. MARIETTE, *Sérapéum*, pls. 26-7; MALININE [etc.], *Cat.* i, pl. viii [22-3], pp. 21-3; DEVÉRIA squeezes, 6165, i. 39, 38; WILKINSON MSS. xxiv. 15, 16; names and titles, LEGRAIN in *Rec. Trav.* xxix (1907), pp. 179-80; LIEBLEIN, *Dict.* Nos. 1012-13; see YOYOTTE in *Mélanges Maspero*, i [4], p. 124 [4, 5]. IM.3697, ARCHIVES phot. E.654; text, CHASSINAT in *Rec. Trav.* xxii (1900), pp. 10-11 [xxxix]; incomplete, MARIETTE, *Sérapéum*, *Texte*, pp. 161-3 = id. *Renseignements* (1855), pp. 95-6 (repr. in *Bibl. Ég.* xviii, pp. 194-7); BRUGSCH, *Thes.* 967 [bottom]-968.

Pezai , God's father of Ptaḥ, Prophet of Hathor Mistress of Hetept in Khanūfer, etc., son of Pemu , with King Pemu offering bread to bull-headed Apis and [Hathor], and Pezai behind, painted, IM.3441 [N.414; A.F.122; S.1907]. MALININE [etc.], *Cat.* i, pl. ix [25], pp. 24-5; WILKINSON MSS. xxiv. 24 [right upper], 34 [left lower]; text, CHASSINAT in *Rec. Trav.* xxi (1899), pp. 58-9 [i]; ČERNÝ Notebook, 117, p. 23 [upper]; titles, see VANDIER in *Rev. d'Ég.* 17 (1965), p. 97 [E.lxxiii]; see PIERRET, *Cat.* No. 276.

Senbef , Prophet of the phyle of the 3rd month, etc., IM.4205 [S.1906; No. 35]. MARIETTE, *Sérapéum*, pl. 28 [right]; MALININE [etc.], *Cat.* i, pl. ix [24], p. 24; WILKINSON MSS. xxiv. 14 [right].

Perhaps this Apis.

Stela, Ḥarwen , God's father of Amūn, son of Iuf'ankh , and another man before bull-headed Apis, now lost. MARIETTE, *Sérapéum*, pl. 25 [3]; MALININE [etc.], *Cat. i*, pl. xiv [45] (from MARIETTE), p. 43.

APIS XXXI [V OF DYN. XXII] of Mariette.

Year 4 of Sesonchis V according to Mariette, but this is unlikely since none of the known stelae of year 4 (see *infra*) bears this name. Chamber Q of Mariette, F' of Rhoné.

Stelae. Ascribed to this Apis-bull by Mariette. In Louvre.



Rekhsuptah  and brother Zeptaḥef'ankh, both Singers of the Temple of Ptaḥ, IM.3432 [S.1977; No. 38]. MARIETTE, *Sérapéum*, pl. 29 [lower left]; MALININE [etc.], *Cat. i*, pl. xiv [46], p. 44. Text, CHASSINAT in *Rec. Trav.* xxii (1900), pp. 11–12 [xl]. Three names, LIEBLEIN, *Dict.* No. 1023. See REVILLOUT, *Cat.* No. 412.

Wenamūn , IM.3034 [N.419; No. 58]. MALININE [etc.], *Cat. i*, pl. xx [68], p. 60; text, CHASSINAT, *op. cit.* xxii (1900), p. 14 [xliv]; see REVILLOUT, *Cat.* No. 419.



APIS XXXII [VI OF DYN. XXII] of Mariette. Year 11 of Sesonchis V.

Stelae. In Louvre.

Year 11.

'Ankhefenubaste , son of Pashenēsi , both God's fathers, etc., IM.3719 [No. 37]. MALININE [etc.], *Cat. i*, pl. ix [27], pp. 26–7.

Ḥor, Inspector of *sem*-priests, etc., kneeling before Apis-bull at top, with three people prostrate behind, IM.3049 [N.469; A.F.124; S.1933]. MARIETTE, *Sérapéum*, pl. 30 [upper]; MALININE [etc.], *Cat. i*, pl. ix [26], pp. 25–6; see PIERRET, *Cat.* No. 277.

Zeptaḥef'ankh, Door-opener of the Temple (of Ptaḥ), son of Ḥetep-ptah , and Taruy , IM.3061 [N.421/36; No. 388]. MARIETTE, *Sérapéum*, pl. 30 [lower left]; MALININE [etc.], *Cat. i*, pl. x [28], pp. 27–8; text, CHASSINAT in *Rec. Trav.* xxiii (1901), pp. 82–3 [cxxxix]; ČERNÝ Notebook, 117, p. 11 [upper]; see PIERRET, *Cat.* No. 280.

Probably temp. Sesonchis V.

Ir'ahap , Door-opener of the Temple of Ptaḥ, son of Ḥetep-ptah (same as above), IM.2702 [No. 62]. MARIETTE, *Sérapéum*, pl. 30 [lower right]; MALININE [etc.], *Cat. i*, pl. x [29], pp. 28–9; text, CHASSINAT in *Rec. Trav.* xxii (1900), p. 15 [xliv]; see REVILLOUT, *Cat.* No. 423.

Thonūfer , IM.3110 [No. 124]. MALININE [etc.], *Cat. i*, pl. x [30], p. 29; see REVILLOUT, *Cat.* No. 456.



Pedeamūn-paiat , IM.3427 [N.421/35; S.1929; No. 59]. MALININE [etc.], *Cat. i*, pl. xxiii [77], p. 66; text, CHASSINAT in *Rec. Trav.* xxii (1900), p. 14 [xlvi]; see REVILLOUT, *Cat.* No. 420.

APIS XXXIII [VII OF DYN. XXII] of Mariette. Year 37 of Sesonchis V.

Chamber R of Mariette, F'' of Rhoné.

Stelae.

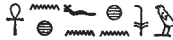

In Cairo Museum

‘Ankhefenkhons , son of Paseshor , both Secretaries of the Place of Truth, two registers, I, Sesonchis V offering bread to Apis-bull, with ‘Ankhefenkhons kneeling behind, II, 8 lines of cursive text, year 37. MARIETTE, *Voyage*, i, on pl. 13, p. 44; id. *Album du Musée de Boulaq* (1872), on pl. 37; text, BRUGSCH, *Thes.* 998–1000; names, LIEBLEIN, *Dict.* No. 2291; see MASPERO, *Guide* (1914), p. 458 [4497].

In Louvre



Year 37.

Gemnefharbak (?), son of ‘Ankh-khons , both God’s fathers, IM.2690 [No. 40]. MALININE [etc.], *Cat.* i, pl. xiii [40], pp. 39–40; text, ČERNÝ Notebook, 117, p. 5 [lower]; names, LIEBLEIN, *Dict.* No. 1199.

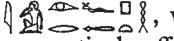



Harwoz , Inspector of *sem*-priests in the Temple of Sokari, etc., son of Tadeneb(t)hen  (woman), sides in form of obelisks, year [3]7, IM.3595 [No. 83]. MARIETTE, *Sérapéum*, pl. 32 [lower right]; MALININE [etc.], *Cat.* i, pl. xi [34], pp. 33–4; see REVILLOUT, *Cat.* No. 431.

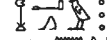
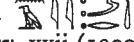

Hepiu  Δ, God’s father, etc., son of Irefa(en)ptah , with double-scene at top, Sesonchis V followed by Hepiu and son Ptaḥhotp respectively offering to bull-headed Apis, IM.3085 [No. 80]. MALININE [etc.], *Cat.* i, pl. xii [36], pp. 35–6; text, ČERNÝ Notebook, 117, p. 17; see REVILLOUT, *Cat.* No. 428.

Heribek , son of Khuwennefer , Ptaḥhotp, son of Estaneb . . . , and others, IM.3079 [No. 75]. MALININE [etc.], *Cat.* i, pl. xi [32], pp. 31–2; WILKINSON MSS. xxiv. 13 [left lower].

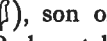

Kereferptah , God’s father, etc., son of Tentnefertem  (woman), IM.3084 [No. 77]. MALININE [etc.], *Cat.* i, pl. xi [33], pp. 32–3.

Kha’su(en)amūn , Inspector of *sem*-priests, *wnrw*-priest in Letopolis, etc., son of Nemareth , IM.3143 [No. 85]. Id. ib. i, pl. xiii [39], pp. 38–9; CHASSINAT in *Rec. Trav.* xxii (1900), p. 16 [lii].

Paseshor , Prophet of Neith, son of Hemptah , Overseer of the prophets in Heracleopolis Magna, Commander of the army, etc., and Irterau , Prophetess of Hathor in Heracleopolis Magna, with genealogy including Nemareth , son of Osorkon II and Wezmutankhes , giving the date of birth of the Apis-bull as year 11, IM.2846 [N.481; A.F.123; S.1959]. MARIETTE, *Sérapéum*, pl. 31; MALININE [etc.], *Cat.* i, pl. x [31], pp. 30–1; WILKINSON MSS. xxiv. 24 [left]. Text in lower register, LEPSIUS, *Über die XXII. ägyptische Königsdynastie* [etc.] in *Abhandlungen der Königl. Preuss. Akademie der Wissenschaften zu Berlin, Philos.-hist. Kl.* (1856), pp. 267–8. Genealogies (some incomplete), LIEBLEIN, *Dict.* No. 1008; id. in *Rev. Arch.* n.s. xviii (1868), pp. 282–3 [i]; LEGRAIN in *Rec. Trav.* xxxi (1909), pp. 1–2. See MARIETTE, *Sérapéum, Texte*, pp. 169–70 = id. *Ren-seignements* (1855), pp. 98–9 (repr. in *Bibl. Ég.* xviii, pp. 206–7); DE ROUGÉ, *Notice sommaire* (1876), p. 66; PIERRET, *Cat.* No. 278.

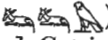
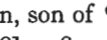

Pashenptah , Prophet of Ptaḥ, Prophet in Smen-ma’et () son of ‘Ankhsemtu , same titles, at top, Sesonchis V libating to Apis-bull, with Pashenptah kneeling behind, IM.3078 [N.488]. MALININE [etc.], *Cat.* i, pl. xii [37], p. 37; text (incomplete), DARESSY in *Rec. Trav.* xxxv (1913), p. 136 [vii]; part, xi (1889), p. 80 [middle]; see PIERRET, *Cat.* No. 279.



Paiuenhor  (also ) , Craftsman, son of 'Ankhpekhrod  , IM.2692 [No. 98]. MALININE [etc.], *Cat. i*, pl. xxviii [98], p. 80; see REVILLOUT, *Cat. No. 441*.



Senbef , *wrrw*-priest in Letopolis, etc., son of 'Ankh-sheshonk  , IM.5947 [No. 106]. MALININE [etc.], *Cat. i*, pl. xxviii [100], pp. 81-2; see REVILLOUT, *Cat. No. 446*.

Name uncertain, Door-opener of Ptaḥ, son of Dḥout , same title, IM.3035 [N.421/284; S.2198; No. 299]. MALININE [etc.], *Cat. i*, pl. xxviii [99], p. 81.

Probably Dyn. XXIV and from here.

Afti  (perhaps also ) , daughter(?) of 'Ankh-ḥor, IM.2679 [No. 430]. MALININE [etc.], *Cat. i*, pl. xxx [105], pp. 85-6.

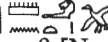
'Akheperrē(?)  , Door-opener of Ptaḥ, son of Pash(en)mehyt  and Ḥathoremḥēt , with bull-headed Apis, IM.3580 [N.677]. *Id. ib. i*, pl. xxxiv [120], pp. 95-6; see PIERRET, *Cat. No. 285*.

Amen(em)ḥēt-pamesha'  , God's father, son of Paneḥesi  , Inspector of *sem*-priests, etc., IM.3118 [No. 108]. MALININE [etc.], *Cat. i*, pl. xxxii [115], p. 92; MARIETTE, *Sérapéum*, pl. 34 [bottom right]; text, CHASSINAT in *Rec. Trav.* xxii (1900), p. 17 [lvi]; see REVILLOUT, *Cat. No. 447*.

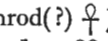
'Ankhpekhrod(?)  , IM.5948 [N.421/107; No. 118]. MALININE [etc.], *Cat. i*, pl. xxxi [109], p. 88; see REVILLOUT, *Cat. No. 451*.

Bekenrenef  , God's father, son of Ḥarwoz, same title, IM.3106 [N.677]. MALININE [etc.], *Cat. i*, pl. xxxii [113], pp. 90-1; text, CHASSINAT in *Rec. Trav.* xxi (1899), p. 61 [xii]; see PIERRET, *Cat. No. 302*.

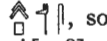
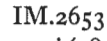
Ḥepuser  , son of Pakharkhons  , IM.2653 [N.679]. MALININE [etc.], *Cat. i*, pl. xxxi [108], p. 87; text, CHASSINAT in *Rec. Trav.* xxi (1899), p. 64 [xviii]; see PIERRET, *Cat. No. 312*.

Hererem  , God's father, son of Pedes  , same title, IM.3113 [N.677]. MALININE [etc.], *Cat. i*, pl. xxxii [114], p. 91; text, CHASSINAT in *Rec. Trav.* xxi (1899), p. 61 [x]; names and titles, LIEBLEIN, *Dict. No. 1174*; see PIERRET, *Cat. No. 300*.

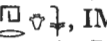
Heribes  , IM.2847 [N.679; No. 323]. MALININE [etc.], *Cat. i*, pl. xxx [104], p. 85; text, CHASSINAT in *Rec. Trav.* xxii (1900), p. 177 [cxxi]; see PIERRET, *Cat. No. 292*.

Ḥetep-ptah, Door-opener of Nefertem Protector of the Two Lands, son of Men  , IM.2757 [N.421; No. 116]. MALININE [etc.], *Cat. i*, pl. xxxi [110], pp. 88-9.

Iraḥap  , IM.3756 [N. 421/38; No. 104]. MALININE [etc.], *Cat. i*, pl. xxxi [111], p. 89; see REVILLOUT, *Cat. No. 445*.

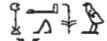
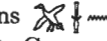
Kha'suenamūn  , God's father, son of Pasenenkhons  . (a) IM.2863 [N.677]; MALININE [etc.], *Cat. i*, pl. xxxii [112], p. 90; text, CHASSINAT in *Rec. Trav.* xxi (1899), p. 59 [iv]; see PIERRET, *Cat. No. 286*. (b) Perhaps same man, IM.3037 [No. 107]; MALININE [etc.], *Cat. i*, pl. xxxiv [122], pp. 97-8; names and titles, LIEBLEIN, *Dict. No. 1198*.

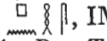
Paneḥesi  , IM.5939 [No. 201]. MALININE [etc.], *Cat. i*, pl. xxx [106], p. 86; text, CHASSINAT in *Rec. Trav.* xxii (1900), p. 22 [lxvi]; see REVILLOUT, *Cat. No. 467*.

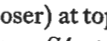
Pedubaste, son of Pen-ḥarwoz  , with names of Neterikhet (Zoser) at top, IM.3036 [N.5442]. MALININE [etc.], *Cat. i*, pl. xxxiii [117], pp. 93-4; MARIETTE, *Sérapéum*, pl. 28 [left] (as Apis IV of Dyn. XXII); WILKINSON MSS. xxiv. 37; see PIERRET, *Cat. No. 281*.

Pef'a-ḥor(?)  , with men kneeling before Apis-bull on sledge at top, IM.4208 [No. 117]. MALININE [etc.], *Cat. i*, pl. xxxiii [116], pp. 92-3.

Pentaōnet  , *warb*-priest, Craftsman, IM.2735 [S.2009; No. 113]. *Id. ib.*, pl. xxix [103], p. 84; see REVILLOUT, *Cat. No. 448*.

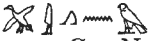
Ptaḥḥotp, Scribe of the divine offerings, son of Paiuenḥor , IM.2673 [No. 90]. MALININE [etc.], *Cat.* i, pl. xxx [107], pp. 86–7; see REVILLOUT, *Cat.* No. 435.

Zeptaḥefcankh, son of Pedes , IM.4162 [N. 421/39; No. 61]. MALININE [etc.], *Cat.* i, pl. xxxiii [118], p. 94; text, CHASSINAT in *Rec. Trav.* xxii (1900), pp. 14–15 [xlviii]; see REVILLOUT, *Cat.* No. 422.

... nakht , IM.2659 [No. 188]. MALININE [etc.], *Cat.* i, pl. xxxiii [119], p. 95.

APIS XXXVI [II OF DYN. XXV] of Mariette. Year 24 of Taharqa.

Chamber (T') of Mariette, (H*) of Rhoné.

Stelae. In Louvre.

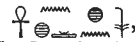
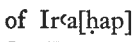
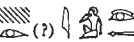

Year 24.

‘Ankh-khons , son of Irca[ḥap]  (??) , with two goddesses, IM.2675. MALININE [etc.], *Cat.* i, pl. xxxv [126], pp. 100–1; VERCOUTTER in *Kush*, viii (1960), pl. xxi [a], p. 68 note 35 (as IM.3146).

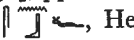

[Ḥar]siēsi, son of Dḥutardais , IM.2705. MALININE [etc.], *Cat.* i, pl. xxxv [127], pp. 101–2.

Ircaḥap , son of Dḥutardais, demotic, IM.2746 [N.454]. Id. ib. i, pl. xxxvi [128], pp. 102–3; VERCOUTTER, op. cit. pl. xxi [b], pp. 68–9 with note 39 (as IM.2705 in error); see PIERRET, *Cat.* No. 303.

Pashensekhmet , IM.2707 [N.421/112; No. 123]. MALININE [etc.], *Cat.* i, pl. xliii [158], pp. 122–3.

Senbef , Hereditary prince, Prophet of Ptaḥ, etc., son of ‘Ankh-unnūfer and Naḥa-tesnakht , before bull-headed Apis, IM.2640 [N.417; S.2018; No. 121]. Id. ib. i, pl. xxxv [125], pp. 99–100; MARIETTE, *Sérapéum*, pl. 35 [left]; WILKINSON MSS. xxiv. 6 [right bottom]. Text, CHASSINAT in *Rec. Trav.* xxii (1900), p. 18 [lvii]; incomplete, REVILLOUT in *Revue Égyptologique*, vii (1896), p. 136 note 1; VERCOUTTER in *Kush*, viii (1960), p. 71. Date, names, and titles, LIEBLEIN, *Dict.* No. 1046. See DE ROUGÉ, *Notice sommaire* (1876), p. 60; REVILLOUT, *Cat.* No. 454.

Probably year 24.

Paraḥarḥa , son of Pederēc , probably IM.2732. MALININE [etc.], *Cat.* i, pl. xliv [159], p. 123.

Pashenēsi, son of Pedenefertem, IM.2763 [N. 421/118]. Id. ib. i, pl. xliv [160], p. 124; text, ČERNÝ Notebook, 117, p. 22 [bottom].

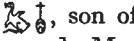
Thonūfer , son of Painmu (owner of stela IM.3424, see *supra*), remains of date, IM.3306 [No. 213]. MALININE [etc.], *Cat.* pl. xlvi [178], p. 136; text, CHASSINAT in *Rec. Trav.* xxii (1900), p. 24 [lxxiv] (as Apis I of Dyn. XXVI).

APIS XXXVII [I OF DYN. XXVI] of Mariette. Years 20/21 of Psammetikhos I.

Chamber T of Mariette, H of Rhoné.

MARIETTE, *Sérapéum, Texte*, pp. 190–2 (repr. in *Bibl. Ég.* xviii, pp. 236–9).



Stelae. In Louvre.

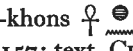

Official stela, with King libating and censng to Apis at top, year 21, giving the date of birth

of the Apis-bull as year 26 of Taharqa, IM.3733 [N.403; S.2035; No. 190]. MALININE [etc.], *Cat.* i, pl. lii [192], p. 146; MARIETTE, *Sérapéum*, pl. 36; PETRIE, *History*, iii, fig. 137; BREASTED, *History*, fig. 182; PARKER in *Kush*, viii (1960), pl. xxxviii, pp. 267–9; DEVÉRIA squeezez, 6165, i. 44; WILKINSON MSS. xxiv. 2 [left]; ARCHIVES phot. E.635. Texts, CHASSINAT in *Rec. Trav.* xxii (1900), p. 19 [lxi]; ČERNÝ Notebook, 117, p. 14 [middle]. Main text, PIEHL, *Inscr. hiéro.* 1 Sér. xxii [C]; MARIETTE, *Sérapéum, Texte*, p. 191 = id. *Renseignements* (1856), p. 75 (repr. in *Bibl. Ég.* xviii, p. 238); REVILLOUT in *Revue Égyptologique*, vii (1896), p. 138 note 1. See id. *Cat.* No. 460; DE ROUGÉ, *Notice sommaire* (1876), p. 61.

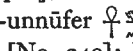
Year 20 (death of the Apis-bull) or 21 (burial).

‘Ankh-khons , son of Ḥarsiēsi, IM.2620 [N.485]. MALININE [etc.], *Cat.* i, pl. lv [205], p. 157; text, CHASSINAT in *Rec. Trav.* xxi (1899), p. 68 [xxviii]; ČERNÝ Notebook, 117, p. 19 [upper]; see PIERRET, *Cat.* No. 330.

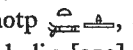
‘Ankh-unnüfer , Judge, son of Esptaḥ, God’s father, and Takhar . (a) IM.2856 [No. 249]; MALININE [etc.], *Cat.* i, pl. lix [217], p. 166; text, CHASSINAT in *Rec. Trav.* xxii (1900), p. 169 [xcv]; names and titles, LIEBLEIN, *Dict.* No. 1139; see REVILLOUT, *Cat.* No. 482. (b) N.421/221 [S.N.54; No. 232], undated; MALININE [etc.], *Cat.* i, pl. lix [220], pp. 168–9; text, CHASSINAT, op. cit. xxii (1900), pp. 164–5 [lxxxv]; names and titles, LIEBLEIN, *Dict.* No. 1222; see REVILLOUT, *Cat.* No. 475.

Atemhotp , son of Ḥeka , God’s father, IM.2867 [No. 273]. MALININE [etc.], *Cat.* i, pl. lix [219], pp. 167–8; text, CHASSINAT, op. cit. xxii (1900), p. 172 [cvi]; see REVILLOUT, *Cat.* No. 492.

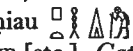
Diptaḥiau , God’s father, *sem*-priest, etc., son of Penamün, IM.3043 [No. 208]. MALININE [etc.], *Cat.* i, pl. lviii [216], p. 165; text, CHASSINAT, op. cit. xxii (1900), p. 23 [lxxi].

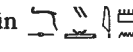
Esamün , IM.2676 [No. 294]. MALININE [etc.], *Cat.* i, pl. lxiv [239], pp. 183–4.

Ḥarenḥap , son of Pa‘ankhi , IM.3087 [N.421/297; S.2082; No. 285].

Ḥarkhebi , son of Esamün, IM.3089 [N.421/111; S.2027; No. 166]. Id. ib. i, pl. lxiii [235], pp. 180–1.

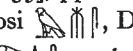
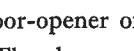
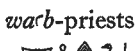
Ḥarmoni , Door-opener of *warb*-priests of the Temple of Ptaḥ, son of Ptaḥardais  and Thes-ḥap-pert , libating to Apis-bull, IM.3072 [S.2178; No. 221]. Id. ib. i, pl. lii [193], p. 147; text, CHASSINAT, op. cit. xxii (1900), p. 26 [lxxx]; names and titles, LIEBLEIN, *Dict.* No. 1219.

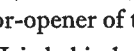
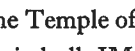

Ḥarwoz , Door-opener of the Temple of Ptaḥ, son of Pennebt-nehēt  and Pen‘aker , with Isis behind Apis-bull, IM.3009 [N.5417]. MALININE [etc.], *Cat.* i, pl. liv [202], p. 154; names, LIEBLEIN, *Dict.* No. 1138; see PIERRET, *Cat.* No. 304.

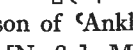
Ḥepardais , IM.2819 [S.2056].

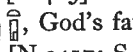
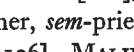
Ḥor, son of ‘Ankh-thekerti , both Singers of the Temple of Ptaḥ, IM.3076 [N.485]. MALININE [etc.], *Cat.* i, pl. lvi [209], p. 160; see PIERRET, *Cat.* No. 310 bis.

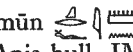
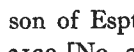
It , God’s father, *sem*-priest, etc., son of Nefertemhotp and Heribesnes , IM.3082 [N.3417; S.2106]. MALININE [etc.], *Cat.* i, pl. liii [195], p. 149; see PIERRET, *Cat.* No. 303 bis.

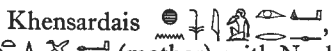

Ḳerfamün , son of Esptaḥ, God’s father, etc., and Kapes  (?), with Isis behind Apis-bull, IM.3129 [No. 250]. MALININE [etc.], *Cat.* i, pl. liv [199], p. 152; text, CHASSINAT in *Rec. Trav.* xxii (1900), p. 169 [xcvi]; names and titles, LIEBLEIN, *Dict.* No. 1225; see REVILLOUT, *Cat.* No. 483.

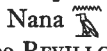
Khensardais , Door-opener of the Temple of Ptaḥ, son of Tadeparēc  (mother), with Nephthys behind Apis-bull, IM.2623 [N.476; S.2038; No. 234]. MALININE [etc.], *Cat.* i, pl. lv [203], p. 155; text, CHASSINAT, op. cit. xxii (1900), p. 165 [lxxxvi]; ČERNÝ Notebook, 117, p. 19 [lower]; see REVILLOUT, *Cat.* No. 476.

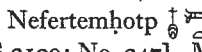
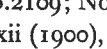
Nana , IM.4058 [S.2159; No. 316]. MALININE [etc.], *Cat.* i, pl. lviii [214], p. 164; see REVILLOUT, *Cat.* No. 500.

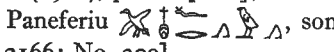
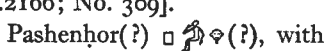

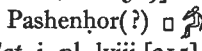
Nefertemḥotp , God's father, *sem*-priest, etc., son of It and Imut , IM.3130 [S.2109; No. 247]. MALININE [etc.], *Cat.* i, pl. liii [196], pp. 149–50; text, CHASSINAT, op. cit. xxii (1900), p. 168 [xciii]; see REVILLOUT, *Cat.* No. 480.

Paneferiu , son of Zeptaḥef'ankh , IM.2619 [N.421/287; S.2166; No. 309].

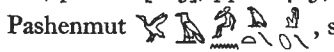
Pashenḥor(?) , with  bark on recto, IM.3046 [No. 150]. MALININE [etc.], *Cat.* i, pl. lviii [215], pp. 164–5; see REVILLOUT, *Cat.* No. 457.

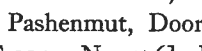
Pashenmut , son of Zeptaḥef'ankh, IM.2681 [N.421/292; S.2048]. Text, ČERNÝ Notebook, 117, p. 21 [lower].

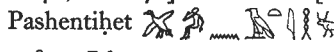
Pashenmut, Door-opener of the Temple of Ptaḥ, son of Pefteu , IM.3027 [S.2041; No. 176]. MALININE [etc.], *Cat.* i, pl. lv [206], pp. 157–8.

Pashentiḥet , Door-opener of the Temple of Ptaḥ, son of Pashenptaḥ , IM.3062 [S.2046; No. 216]. Id. ib. i, pl. lv [204], p. 156.

Pedeḥarenpe , son of Ḥor, S.N.24 [No. 288].

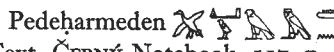
Pedeḥarmeden , son of Uzaḥor, both God's fathers, IM.3045 [S.2131]. Text, ČERNÝ Notebook, 117, p. 5 [upper].

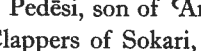
Pedes , son of Ḥeka , IM.2685 [N.421/289]. Text, id. ib. p. 22 [top].

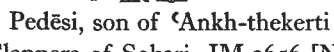
Pedēsi, son of 'Ankh-thekertī , both Singers of the Temple of Ptaḥ, Clappers of Sokari, IM.2656 [N.485]. MALININE [etc.], *Cat.* i, pl. lvi [208], p. 159; text, CHASSINAT in *Rec. Trav.* xxi (1899), pp. 60–1 [ix]; see PIERRET, *Cat.* No. 297.

Pedēsi, S.N.59 [N.421/127; S.2055; No. 139].

Pedubaste, IM.2703.

Pedusiri, son of Amenardais, IM.2621 [S.2172; No. 202]. MALININE [etc.], *Cat.* i, pl. lx [223], p. 171; text, CHASSINAT in *Rec. Trav.* xxii (1900), p. 22 [lxvii]; see REVILLOUT, *Cat.* No. 468.

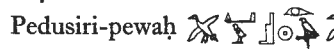
Pedusiri-pewah , son of Bekenrenef, IM.3023 [S.2089; No. 161]. MALININE [etc.], *Cat.* i, pl. lxxv [243], p. 186; text, ČERNÝ Notebook, 117, p. 21 [upper].

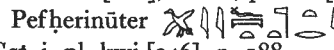
Pefḥerinüter , son of Pedeptaḥ, IM.2734 [S.2104]. MALININE [etc.], *Cat.* i, pl. lxxvi [246], p. 188.

Pefḥerinüter, IM.2768 [S.2057; No. 149].

Pefḥerinüter, IM.3067 [S.2072; No. 128].

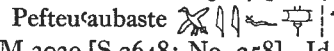
Pefteu'aubaste , God's father, Inspector of *sem*-priests, son of Ḥory, IM.3039 [S.2648; No. 258]. Id. ib. i, pl. lvii [213], p. 163.

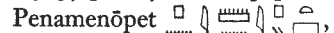
Penamenōpet , son of Pefḥerinüter, IM.2740 [N.421/156; S.2065; No. 162].

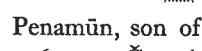
Penamūn, son of Iru , IM.2689 [S.2100; No. 238]. Id. ib. i, pl. lxii [229], pp. 175–6; text, ČERNÝ Notebook, 117, p. 15 [top].

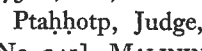
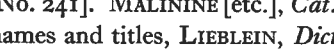

Ptaḥḥotp, Judge, son of Ica , and Keḥḥatenēsi , IM.2624 [No. 241]. MALININE [etc.], *Cat.* i, pl. lx [222], p. 170; text, GOODWIN MSS. 31279, 30 [left]; names and titles, LIEBLEIN, *Dict.* No. 1203; see REVILLOUT, *Cat.* No. 479.

Ptaḥnūfer , son of It and Imut, IM.3077 [S.2105; No. 191]. MALININE [etc.], *Cat.*

i, pl. liii [197], pp. 150–1; WILKINSON MSS. xxiv. 2 [right]; text, CHASSINAT in *Rec. Trav.* xxii (1900), p. 19 [lxii]; see REVILLOUT, *Cat.* No. 461.

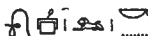
Senbef, son of 'Ankh-sheshonḫ and Mer(yt)ptah , IM.5342 [No. 353]. Text, CHASSINAT in *Rec. Trav.* xxiii (1901), p. 76 [cxxxix].

Userken , IM.3053 [N.421/272; No. 422].

Uzāhorresnet  and Weḥebrēc , both sons of It and Imut, IM.3075 [No. 317]. MALININE [etc.], *Cat.* i, pl. liii [198], pp. 151–2; text, CHASSINAT in *Rec. Trav.* xxii (1900), p. 174 [cxiii]; names and titles, cf. LIEBLEIN, *Dict.* No. 1140; see REVILLOUT, *Cat.* No. 501.

Zeamūnef'ankh, IM.3591 [No. 194]. MALININE [etc.], *Cat.* i, pl. lxi [225], pp. 172–3; see REVILLOUT, *Cat.* No. 464.



Names lost or uncertain. E.5639 [S.N.63] (formerly in Rousset Bey Colln.). IM.2662 [No. 160]. IM.2706 [N.421/299; S.2168; No. 303]. IM.3063 [No. 225], MALININE [etc.], *Cat.* i, pl. lvi [207], pp. 158–9. IM.3105 [S.2079; No. 186]. S.2073 [No. 156]. S.2127. S.2128 [No. 301] (name of the King only).

Undated.

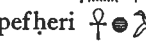

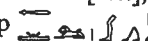
Amennezem , son of Zeamūnef'ankh, Door-opener, IM.2642 [S.2077].

'Ankhpefḥeri , with Isis behind Apis-bull, IM.3579 [N.421/244; S.2151; No. 270]. MALININE [etc.], *Cat.* i, pl. liv [200], p. 153; see REVILLOUT, *Cat.* No. 490.

'Arptaḥ-ḥap , IM.3574 [S.2067; No. 185]. MALININE [etc.], *Cat.* i, pl. lxxv [242], p. 185.

Eshu , son of Pataenruz , IM.3134 [No. 218]. Text, CHASSINAT in *Rec. Trav.* xxii (1900), p. 25 [lxxvii].

Ḥarenḥap , son of (Pa)she(n)mut , IM.3057 [S.2101; No. 165]. MALININE [etc.], *Cat.* i, pl. lxiv [237], pp. 182–3.

Ḥarḥap , son of Shesepamūn-tefḥert , IM.3029 [N.421/256; No. 275].

Ḥarsiēsi, with Isis behind Apis-bull, IM.3318 [N.421/263; S.2152; No. 278]. *Id. ib.* i, pl. liv [201], pp. 153–4; see REVILLOUT, *Cat.* No. 494.

Ḥarsiēsi, son of Meḥamenwia , IM.3757 [No. 168]. MALININE [etc.], *Cat.* i, pl. lxxvi [248], p. 189.

Ḥepardais , son of Amenardais, IM.2699 [S.2050; No. 155].

Ḥor, God's father, son of Pashenēsi, God's father in the Temple of Ptaḥ, IM.3132 [No. 259]. See REVILLOUT, *Cat.* No. 485.

Ḥui , *wab*-priest, son of Pashenēsi, IM.2764 [S.2197; No. 230]. Text, CHASSINAT, *op. cit.* xxii (1900), p. 164 [lxxxiii].



Ip , son of Ḥetep-ptah. (a) IM.2665 [S.2092; No. 158], MALININE [etc.], *Cat.* i, pl. lxii [230], pp. 176–7; text, ČERNÝ Notebook, 117, p. 8; some names and titles, LIEBLEIN, *Dict.* No. 1200. (b) IM.2787 [S.2069; No. 169], MALININE [etc.], *Cat.* i, pl. lxiv [240], p. 184; text, CHASSINAT, *op. cit.* xxii (1900), p. 18 [lix].



Iputi , son of Tade  (mother), IM.3031 [S.2213; No. 281].

Ir'ahor(?) , IM.3104 [S.1892; No. 227]. MALININE [etc.], *Cat.* i, pl. lxi [226], p. 173; text, CHASSINAT, *op. cit.* xxii (1900), p. 26 [lxxxii]; see REVILLOUT, *Cat.* No. 472.

Irḥap , IM.2853 [N.421/293; S.2093; No. 284]. MALININE [etc.], *Cat.* i, pl. lxiii [236], pp. 181–2.

Iufta , God's father, *sem*-priest, IM.2866 [N.677]. See PIERRET, *Cat.* No. 316.

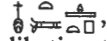

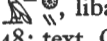
Memi(?) , God's father, son of Panehesi , Scribe of  of the Temple of Ptaḥ, etc., IM.3428 [S.2196; No. 179].



Nefertemḥotp , God's father, *sem*-priest, etc., son of Buiruteha  and Tata , libating to Apis-bull, IM.3142 [No. 248]. MALININE [etc.], *Cat.* i, pl. lii [194], p. 148; text, CHASSINAT in *Rec. Trav.* xxii (1900), pp. 168-9 [xciv]; names and titles, LIEBLEIN, *Dict.* No. 1224; see REVILLOUT, *Cat.* No. 481.

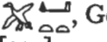

Nekht-ḥaremḥab , son of Ḥetep-ptah, IM.2854 [N.421/296; S.2090; No. 293]. MALININE [etc.], *Cat.* i, pl. lxiii [234], pp. 179-80.

Paba . . . , son of Pashenptah, IM.3112.

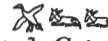
Pade , God's father, son of Ḥarsiēsi, IM.2789 [N.421/254; S.1885; No. 274]. *Id. ib.* i, pl. lx [221], p. 169; text, CHASSINAT, *op. cit.* xxii (1900), p. 172 [cvii]; see REVILLOUT, *Cat.* No. 493.



Pairkap  and Imḥōtep, sons of Ḥepmen  and Ēsireshti , IM.2861 [No. 318]. Text, CHASSINAT, *op. cit.* xxii (1900), pp. 174-5 [cxiv]; see REVILLOUT, *Cat.* No. 502.

Paiuenḥor , son of Keref , IM.3727 [S.2064; No. 184]. MALININE [etc.], *Cat.* i, pl. lxxv [244], pp. 186-7.

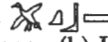

Pakap , son of Senbef , IM.2815 [S.2173; No. 237]. *Id. ib.* i, pl. lx [224], pp. 171-2; text, CHASSINAT, *op. cit.* xxii (1900), pp. 165-6 [lxxxviii]; see REVILLOUT, *Cat.* No. 477.

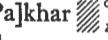
Pakap, IM.2726 [S.2063; No. 137]. MALININE [etc.], *Cat.* i, pl. lxxvii [250], pp. 190-1.

Pakebesh , Singer of Ptaḥ. (a) IM.2858 [No. 271]; names and titles, LIEBLEIN, *Dict.* No. 1223. (b) IM.3108 [S.2186; No. 224].

[Pa]khar , son of Espaper-webekhet , IM.2709 [No. 308].

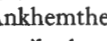
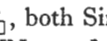

Pashentana , IM.3307 [N.421/279; S.2179; No. 307]. MALININE [etc.], *Cat.* i, pl. lxi [227], p. 174.

Pedeḥarde , son of Pashenmut , IM.3582 [S.2068; No. 142]. *Id. ib.* i, pl. lxvi [247], pp. 188-9.

Pedeneit, son of 'Ankhemthenet  and Sokari , both Singers of the Temple of Ptaḥ, Clappers of Sokari, inscribed on both sides, IM.2658 [No. 211]. *Id. ib.* i, pl. lvii [211], p. 161; text, CHASSINAT, *op. cit.* xxii (1900), p. 24 [lxxiii].

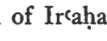

Pedeneit, son of 'Ankh-ḥor, IM.2634 [N.421/258; S.2134; No. 276]. Text, *id. ib.* pp. 172-3 [cviii].

Pedepthah, son of Irtaḥap , IM.2796 [No. 178]. MALININE [etc.], *Cat.* i, pl. lxiii [233], p. 179.

Pedesiptah , son of Ḥepiuiu , IM.2788 [N.421/137; No. 133].

Pede . . . , IM.2663 [S.2093; No. 164]. *Id. ib.* i, pl. lxii [231], pp. 177-8.

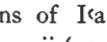
Pedusiri, son of Amenardais, IM.2650 [No. 148]. *Id. ib.* i, pl. lxvi [245], p. 187.

Pedusiri and Amenkha , sons of Ika , IM.2728 [N.421/260; S.2200; No. 277]. Text, CHASSINAT in *Rec. Trav.* xxii (1900), p. 173 [cix].

Pefḥerinüter , IM.5944 [S.2059; No. 129]. MALININE [etc.], *Cat.* i, pl. lxxvii [251], p. 191.

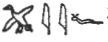
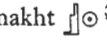
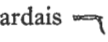
Pefteu'auēsi , son of Usirinakht  and Meḥytardais , IM.3048 [S.2214; No. 245]. Text, CHASSINAT, *op. cit.* xxii (1900), p. 168 [xcii].

Psammethk, Treasurer of the King of Lower Egypt, etc., son of Zeptaḥef'ankh, Singer of the Temple of Ptaḥ, and Ēsi(em)khebi , IM.1805 [N.679]. Text, id. ib. xxi (1899), pp. 64-5 [xx]; see PIERRET, *Cat.* No. 315.



Ptaḥardais(?) , son of Pashenptah, N.421/132 [S.N.75; No. 136]. MALININE [etc.], *Cat.* i, pl. lxi [228], pp. 174-5.

Ptaḥhotp, son of Ptaḥwēr and Ia , IM.2859 [N.421/264; No. 264]. Text, CHASSINAT in *Rec. Trav.* xxii (1900), p. 171 [ciii].

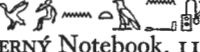
Ptaḥhotp, God's father, son of Gem(n)efḥarbak , IM.3038 [N.421/115; No. 126]. Some names, LIEBLEIN, *Dict.* No. 1218 (as temp. Darius I).

Ptaḥ-khač , son of Pashentanač , IM.2797 [No. 265]. MALININE [etc.], *Cat.* i, pl. lix [218], p. 167; text, ČERNÝ Notebook, 117, p. 15 [middle]; see REVILLOUT, *Cat.* No. 487.

Ptaḥwēr, son of Zeamūnef'ankh, IM.3041 [N.421/338; No. 42]. Text, CHASSINAT, op. cit. xxii (1900), p. 170 [c] (as No. 258).

Shedsunefertem , God's father, *sem*-priest, son of Gem(n)efḥarbak and Sekhmetnefer(t) , IM.3442 [N.421/120; No. 127].

Shedsunefertem, son of Nefertemhotp(?), God's father, *sem*-priest, unnumbered.

Uzahor, *wac*b-priest of the Temple of Ptaḥ, son of Ze[ho], IM.3071 [No. 231]. Text, id. ib. p. 164 [lxxxiv]; see REVILLOUT, *Cat.* No. 474.

Zeamūnef'ankh, son of Ptaḥwēr and Ia, IM.3017 [No. 257]. Text, CHASSINAT, op. cit. xxii (1900), p. 170 [xcix].

Zehō , son of Amenardais, IM.2666 [S.2091; No. 163]. MALININE [etc.], *Cat.* i, pl. lxii [232], p. 178.

Zekhensef'ankh, IM.5428 [S.2142; No. 199]. See REVILLOUT, *Cat.* No. 466.

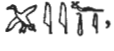
Zeptaḥef'ankh , Door-opener of the Temple of Ptaḥ, son of Pefiti , E.10529. Text, ČERNÝ Notebook, 117, p. 13 [middle].

Zeptaḥef'ankh, God's father, IM.3304 [S.2139; No. 233].

. . . denebwen , Singer of the Temple of Ptaḥ, etc., son of Uzahor, IM.3042 [No. 252]. MALININE, *Cat.* i, pl. lvii [212], p. 162.



Names uncertain. IM.2693 [No. 220]; text, CHASSINAT, op. cit. xxii (1900), p. 26 [lxxix]. IM.2802 [S.2054]. IM.5945 [S.2097; No. 167]; MALININE [etc.], *Cat.* i, pl. lxiv [238], p. 183. S.2146 [No. 255]; text, CHASSINAT, op. cit. xxii (1900), p. 170 [xcviii].

'GREATER VAULTS'.

Plan LXVIII [3]

See MARIETTE, *Sérapéum, Texte*, pp. 46-8, 52-6, 80 [lower]-83. Plan, GUNN in *Ann. Serv.* xxvi (1926), fig. 1 on p. 82; of east part, VERCOUTTER in *Mitt. Kairo*, 16 (1958), fig. 2 (from Mariette papers), pp. 336-7 with note 10.

Doorway with demotic graffiti of year 30 of Ptolemy II Philadelphus, in Louvre, N.420. Texts on jambs, DEVÉRIA squeezes, 6170D, B, C; see BRUGSCH, *Thes.* 993-4 [B]; on south thickness, id. ib. 993 [A]. See DE ROUGÉ, *Notice sommaire* (1876), p. 62; MARIETTE, *Sérapéum, Texte*, p. 57, cf. pl. F [f] on p. 43; BOREUX, *Guide*, i, pp. 169-70; VANDIER, *Guide* (1948), p. 25; (1952), p. 26; (1973), pp. 55-6.

Hieroglyphic graffiti of Imḥōtep son of Ḥor, Hetepniḥap , son of Imḥōtep, Ḥarneziotef , son of Imḥōtep, and others. WILKINSON MSS. xviii. 36 [lower]-37.

APIS XXXVIII [II OF DYN. XXVI] of Mariette. Year 52 of Psammetikhos I.

Chamber U of Mariette, I of Rhoné.

Official stela, in Louvre, E.3335 [No. 239]. DEVÉRIA squeezes, 6168, 5. Text, MARIETTE, *Sérapéum, Texte*, pp. 198–9 = id. *Renseignements* (1856), pp. 78–80 (repr. in *Bibl. Ég.* xviii, pp. 248–9); CHASSINAT in *Rec. Trav.* xxii (1900), p. 166 [lxxxix]. See DE ROUGÉ, *Notice sommaire* (1876), p. 61; BOREUX, *Guide*, i, p. 171; VANDIER, *Guide* (1948), p. 25; (1952), p. 26; (1973), p. 57.

APIS XXXIX [III OF DYN. XXVI] of Mariette. Year 16 of Necho II.

Chamber V of Mariette, J of Rhoné.

Official stela, with bull-headed Apis at top, giving the date of birth of the Apis-bull as year 53 of Psammetikhos I, in Louvre, IM.133 [N.404; S.2243; No. 193]. PETRIE, *History*, iii, fig. 143; WILKINSON MSS. xxiv. 1 [lower]; ARCHIVES phot. E.653. Text, CHASSINAT in *Rec. Trav.* xxii (1900), pp. 20–1 [lxiv]; main text, PIEHL, *Inscr. hiéro.* 1 Sér. xxi [A]. See DE ROUGÉ, *Notice sommaire* (1876), p. 61; REVILLOUT, *Cat.* No. 463; BOREUX, *Guide*, i, p. 172; VANDIER, *Guide* (1948), p. 25; (1952), p. 26; (1973), p. 56.

APIS XL [IV OF DYN. XXVI] of Mariette. Year 12 of Apries.

Chamber X of Mariette, K of Rhoné.

Official stela, with bull-headed Apis at top, giving the date of birth of the Apis-bull as year 16 of Necho II, in Louvre, IM.132 [N.405; S.2244; No. 240]. MARIETTE, *Choix de monuments*, pl. vii, pp. 10–11 (repr. in *Bibl. Ég.* xviii, pl. vii, pp. 316–18); WILKINSON MSS. xxiv. 4 [left]; DEVÉRIA squeezes, 6165, i. 46; 6169, 42; ARCHIVES phot. E.638. Text, CHASSINAT in *Rec. Trav.* xxii (1900), p. 167 [xc]; main text, PIEHL, *Inscr. hiéro.* 1 Sér. xxi–xxii [B]. See DE ROUGÉ, *Notice sommaire* (1876), p. 61; REVILLOUT, *Cat.* No. 478; BOREUX, *Guide*, i, p. 172; VANDIER, *Guide* (1948), p. 25; (1952), p. 26; (1973), p. 57.

APIS XLI [V OF DYN. XXVI] of Mariette. Year 23 of Amasis.



Chamber Y of Mariette, L of Rhoné.

Granite sarcophagus, with lid lying near entrance. Text, BRUGSCH, *Thes.* 966–7 [2]; GUNN in *Ann. Serv.* xxvi (1926), pp. 83–4; of lid, DEVÉRIA squeezes, 6170B, 1.



Stelae. In Louvre.

Official stela, with King kneeling before Apis-bull at top, giving the date of birth of the Apis-bull as year 5, IM.4131 [N.406; S.2259; No. 192]. VERCOUTTER in *Mitt. Kairo*, 16 (1958), Taf. xxxii, p. 334; *Encycl. phot. Louvre*, pls. 156–7; WILKINSON MSS. xxiv. 3; DEVÉRIA squeezes, 6169, i. 43; 6170D, 5; ARCHIVES phot. E.636; upper part, MASPERO, *Hist. anc.* iii, fig. on p. 642. Text, CHASSINAT in *Rec. Trav.* xxii (1900), p. 20 [lxiii]; main text, PIEHL, *Inscr. hiéro.* 1 Sér. xx [H]; beginning, REVILLOUT in *Revue Égyptologique*, i (1880), p. 62 note 1. See GUNN in *Ann. Serv.* xxvi (1926), pp. 92–4; DE ROUGÉ, *Notice sommaire* (1876), p. 61; REVILLOUT, *Cat.* No. 462; BOREUX, *Guide*, i, p. 172; VANDIER, *Guide* (1948), p. 25; (1952), p. 26; (1973), p. 57.

Year 23.

Penptah , Director of the estates of Neith, etc., son of Uzaḥor-meḥent  and Sitpep . (a) IM.3011 [N.421/346; No. 337]; text, CHASSINAT in *Rec. Trav.* xxii

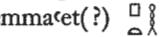
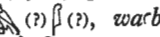
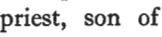
(1900), p. 177 [cxx]; GOODWIN MSS. 31279, 32 [lower]; see VERCOUTTER, *Textes*, p. 24 [b] (as IM.3001); REVILLOUT, *Cat.* No. 511. (b) IM.4192 [N.421/331; No. 350], undated; text, CHASSINAT, op. cit. xxii (1900), p. 180 [cxxvii].

Ptaḥemmat(?)  (?) , *waḥb*-priest, son of Zeiuenptah , God's father, and Mertiotēs , IM.4002 [No. 503]. See PIERRET, *Cat.* No. 307.

Temp. Amasis, undated.



Upper part, [King] adoring Apis-bull and seated Osiris, IM.4074 [No. 325]. Text, CHASSINAT in *Rec. Trav.* xxii (1900), pp. 175–6 [cxvii]; see REVILLOUT, *Cat.* No. 505.

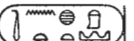

Pasenenkhons , son of King Amasis and Nekhtubasterau, IM.4053 [No. 266]. Text, CHASSINAT, op. cit. xxii (1900), p. 171 [civ]; see REVILLOUT, *Cat.* No. 488.

Psammethek (later King Psammetikhos III), son of King Amasis and Tent-kheta  IM.4034 [N.486; S.2252]. VERCOUTTER, *Textes*, pl. v, pp. 37–43; WILKINSON MSS. xxiv. 24 [right lower]. Text, CHASSINAT in *Rec. Trav.* xxi (1899), p. 63 [xvi]; ČERNÝ Notebook, 117, p. 18 [upper]. See DE ROUGÉ, *Notice sommaire* (1876), p. 66; PIERRET, *Cat.* No. 309.

Probably temp. Amasis. Not necessarily Apis V of Dyn. XXVI.

‘Aḥmosi, son of Heribamūn , both Commanders of the army, and [Sety]erboni, IM.4175. Text, CHASSINAT in *Rec. Trav.* xxi (1899), pp. 68–9 [xxx] (as Apis V of Dyn. XXVI); see PIERRET, *Cat.* No. 333.



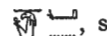

‘Ankh-unnūfer , God's father, Prophet of Isis, son of Ptaḥhotp and Thekhet , IM.4009 [N.421/350; No. 365]. VERCOUTTER, *Textes*, pl. iv, pp. 34–6; text, CHASSINAT, op. cit. xxiii (1901), pp. 79–80 [cxxxiv]; names and titles, LIEBLEIN, *Dict.* No. 1045; see REVILLOUT, *Cat.* No. 529.

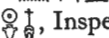
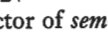

Ḥarkhebi , (perhaps not dedicator of the stela, but one of relatives), son of Taseñhor , (mother), IM.64.

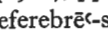

Ḥarshefnakht(?) , son of Weḥbrēc-mer(y)ptah , both God's fathers and Prophets of Amen-rēc foremost of the Temples, Prophets of Pepy, etc., IM.4040 [No. 424]. Text, CHASSINAT, op. cit. xxv (1903), p. 51 [clx]; ČERNÝ Notebook, 117, p. 16 [upper]; see REVILLOUT, *Cat.* No. 539.

Khensardais , son of Atemardais and Mutar[dais], IM.4170.

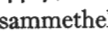
Neferebrēc , Inspector of *sem*-priests, Secretary of the King, etc., son of Psammethek and Esnebttai , (a) IM.3148 [N.479]; text, CHASSINAT, op. cit. xxi (1899), p. 62 [xiii] (as Apis IV of Dyn. XXVI); see PIERRET, *Cat.* No. 305 (as N.671/3148); VERCOUTTER, *Textes*, pp. 24–6 [c]. (b) IM.4110 [N.421/342; No. 336]; id. ib. pl. vii, pp. 48–58; text, CHASSINAT, op. cit. xxii (1900), pp. 176–7 [cxix]; see REVILLOUT, *Cat.* No. 510.

Panehesi , Neferebrēc-sonb , *ḥwn*-priest of Bubastis, son of Pathenfi  and Iḥ-neferu , temp. Amasis, IM.4051 [No. 322]. VERCOUTTER, *Textes*, pl. vi, pp. 44–7; text, CHASSINAT, op. cit. xxii (1900), p. 175 [cxvi].

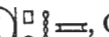
Psammethek-emakhet , son of ‘Ankh-weḥbrēc  and Wendeshes , IM.4174. Names and titles, LIEBLEIN, *Dict.* No. 1157.

Psammethek-meryptah , Overseer of the royal freight boats, etc., son of Ḥarkhons  and Pepy-meriotes , IM.4019 [No. 333]. Text, CHASSINAT, op. cit. xxii (1900), p. 176 [cxviii]; GOODWIN MSS. 31279, 33 [lower]; names and titles, LIEBLEIN, *Dict.* No. 1144.

Psammethek-sonb, Mayor in Sais, etc., son of Hory, God's father, and Sopdetiyti $\Delta^* \Delta \Delta$, IM.4128.

Thaiharimu $\Delta \Delta \Delta \Delta$, God's father, Secretary of Ra-setau, etc., son of Sekhemfankh-ptah $\Delta \Delta \Delta \Delta$ and Hēpet $\Delta \Delta$, IM.3114 [N.421/327; No. 349]. Text, CHASSINAT, op. cit. xxii (1900), p. 179 [cxxvi] (as IM.3714 in error); see REVILLOUT, *Cat.* No. 519.

Wehebrēc-unnūfer $\Delta \Delta \Delta \Delta$, Overseer of the seal, Prophet of Isis and Nephthys, etc., son of Harsiēsi and Estanefert $\Delta \Delta \Delta \Delta$, quartzite, IM.4100. VERCOUTTER, *Textes*, pl. iii, pp. 27-33.

APIS XLII of Mariette. Year 6 of Cambyses.

Chamber Z of Mariette, M of Rhoné.

Text on lid of sarcophagus, GUNN in *Ann. Serv.* xxvi (1926), p. 85.

Official stela, giving the date probably of birth of the Apis-bull as year 27 (of Amasis), in Louvre, IM.4133 [N.407; S.N.83; S.2287; No. 354]. POSENER, *La Première domination perse en Égypte*, pl. ii, pp. 30-5; ARCHIVES phot. E.896. Lines 1 and 2 of text, REVILLOUT in *Revue Égyptologique*, i (1880), pp. 71-2 note 1. See DE ROUGÉ, *Notice sommaire* (1876), p. 61.

APIS XLIII. See *infra*.

APIS XLIV of Mariette. Year 4 of Darius I.

Chamber B' of Mariette, N' of Rhoné.

Stelae. In Louvre.

Year 4.

Official stela, giving the date of birth of the Apis-bull as year 5 of Cambyses, fragmentary, IM.4187 [N.408; S.2274; No. 357]. POSENER, op. cit. pl. iii, pp. 36-41; ARCHIVES phot. E.655; DEVÉRIA squeezes, 6165, i. 53. Text, CHASSINAT in *Rec. Trav.* xxiii (1901), pp. 77-8 [cxxxii]. See DE ROUGÉ, *Notice sommaire* (1876), p. 61.

Hekaemsaf $\Delta \Delta \Delta \Delta$, son of Irefta(en)ptah $\Delta \Delta \Delta \Delta$, both God's fathers, Heads of door-openers, etc., IM.4013. ARCHIVES phot. E.637; text, CHASSINAT, op. cit. xxiii (1901), pp. 76-7 [cxxx] (as IM.4012 and No. 355); names and titles, LIEBLEIN, *Dict.* No. 1051.

Pefneit $\Delta \Delta \Delta \Delta$, son of Harkhebi, both *sem*-priests, *wp-ntrw*y, etc., IM.4086. See PIERRET, *Cat.* No. 320.



Pensekhmet $\Delta \Delta \Delta \Delta$ ^{sic}, son of Ptašshepses, both God's fathers, *wmrw*-priests in Letopolis, etc., and Irti $\Delta \Delta \Delta \Delta$, IM.4188. Text, ČERNÝ Notebook, 117, p. 7 [lower].

Psammethek-meryneit, son of Pashenptah, God's father, *ḳḥ*-priest, IM.3131 [N.421/355].

Ptaḥhotp, God's father in the 1st phyle, *sem*-priest, son of Esunnūfer $\Delta \Delta \Delta \Delta$, IM.4054 [No. 366]. Text, CHASSINAT, op. cit. xxiii (1901), pp. 80-1 [cxxxv].



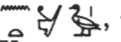



Probably year 4.

‘Aḥmosi, son of Paiuenḥor $\Delta \Delta \Delta \Delta$, both Commanders of the army, and Taḳapenkhebi $\Delta \Delta \Delta \Delta$. (a) IM.4017 [No. 359]; VERCOUTTER, *Textes*, pl. viii, pp. 59-64; DEVÉRIA squeezes, 6165, i. 47; ARCHIVES phot. E.1175; text, PIERRET, *Rec. inscr.* i, pp. 67-9; CHASSINAT in *Rec. Trav.* xxiii (1901), p. 78 [cxxxii]; POSENER, *La Première domination perse en Égypte*, pp. 42-3, cf. 41, 44-6; names and titles, LIEBLEIN, *Dict.* No. 1214; see REVILLOUT, *Cat.* No. 527. (b) N.421/317 [S.N.88; No. 330]; text, POSENER, op. cit. pp. 47, cf. 46.

‘Aḥmosi, Director of the estates, *w nrw*-priest, etc., son of Psammethek-sineit 
, Chief lector-priest, and Tashentiḥet , IM.4129 [N.421/402; No. 417].
 VERCOUTTER, op. cit. pl. xvi, pp. 105–8; text, CHASSINAT, op. cit. xxv (1903), p. 50 [clvi].

Ḥarwoz, Hereditary prince, etc., son of Tesnakht  (mother), IM.4057. See BOTHMER, *Eg. Sculp.* pp. 72, 73.

Pashenptaḥ, God's father and Prophet of Ptaḥ, son of Pedepptaḥ, God's father and Prophet of Bubastis Mistress of ‘Ankhtaui, IM.4118.



Pedeharemḥab , Royal scribe under Amasis, etc., son of Uzaḥorresnet 
, Prophet of Ḥa, etc., and Shep(en)sopdet   , IM.4018 [No. 339]. VERCOUTTER, op. cit. pl. ix, pp. 65–9; text, CHASSINAT, op. cit. xxii (1900), p. 178 [cxxxiii] (as Apis V of Dynasty XXVI); see REVILLOUT, *Cat.* No. 513.

Lower part of a stela, IM.4116.

APIS XLV of Mariette. Temp. Darius I.

Chamber C' of Mariette, N'' of Rhoné.

Stelae dated between years 4 and 34 of Darius I.

Esbanebbed , *sem*-priest, *w p-ntrw y*, son of Shedsunefertem  and Irterau, year 31, in Louvre. (a) IM.4016 [No. 362]; part of text, BRUGSCH, *Thes.* 969 [4]; id. in *A.Z.* xxii (1884), pp. 115–16; date and cartouche, WILKINSON MSS. xxiv. 19 [4]. (b) Probably same man, IM.4068.

Ptaḥḥotp, year 31 (or 34), in Louvre, S.N.74.

APIS XLIII of Mariette. Year 34 of Darius I.



Chamber A' of Mariette, N of Rhoné. Identification doubtful.

Stelae.



Year 34.

In Louvre.



Official stela, inscribed in ink, IM.4039. VERCOUTTER, *Textes*, pl. x, pp. 70–7.



Ḥarkhebi , son of Tabes  (mother), IM.4045 [N.441a]. Text, WILKINSON MSS. xxiv. 26 [1]; ČERNÝ Notebook, 117, p. 20 [lower]; see PIERRET, *Cat.* No. 322.



Ḥarsiēsi, son of Zeharef'ankh , both God's fathers, *w nrw*-priests, IM.4104 [N.421/476]. Part of text, ČERNÝ Notebook, 117, p. 24 [upper].

Ir'āḥor  . . . ḥap , Secretary of Ra-setau, *khet*-priest of Ḥa, etc., IM.4063 [N.475]. Text, CHASSINAT in *Rec. Trav.* xxi (1899), p. 67 [xxvi]; see PIERRET, *Cat.* No. 326.



Ir'āḥor, *sem*-priest, *w nrw*-priest, etc., son of 'Ankh-psammethk and Werek , IM.4046 [No. 394]. Text, CHASSINAT, op. cit. xxiii (1901), pp. 84–5 [cxlii] (as IM.4045).

Iufa , (same man as Berlin 3423, see *infra*) and Ḥor, *sem*-priests, *kḥ*-priests, etc., sons of Pashenptaḥ  and Neitiḳert , IM.4076 [N.441]. Text, id. ib. xxi (1899), pp. 66–7 [xxv]; see PIERRET, *Cat.* No. 325.



Children of Neferebrē-mer(y)ptaḥ , God's father, Prophet of Sobk, and Tashenpashai , IM.4037 [N.421/652; No. 443]. Text, CHASSINAT, op. cit. xxv (1903), p. 55 [clxvii].



(Pa)shenptah , God's father, *sem*-priest, etc., son of Haremakhet and Tasokari , IM.4008 [N.441]. Text, id. ib. xxi (1899), pp. 65-6 [xxiii]; WILKINSON MSS. xxiv. 25 [left lower]; see PIERRET, *Cat.* No. 323.



Pedubaste, son of Pefteu'aubaste, IM.4072 [N.485]. Text, CHASSINAT, op. cit. xxi (1899), p. 65 [xxii]; see PIERRET, *Cat.* No. 321.

Psammethek-emakhet , Prophet of Ptaḥ, *wnrw*-priest, etc., son of Harsiēsi and Takap , IM.4097 [S.2303; No. 364]. Text, CHASSINAT, op. cit. xxiii (1901), pp. 78-9 [cxxxiii] (as IM.4067); names and titles, LIEBLEIN, *Dict.* No. 1230; see DE ROUGÉ, *Notice sommaire* (1876), p. 62.

Ptaḥhotp, son of Shesepamūn-tefḥert , probably year 34 (or 31), IM.4207.

Semtu-tefnakht , God's father, son of Iračəḥeka , Inspector of *sem*-priests, etc., and Renpetnefert , S.N.72.

Weḥebrēt-emkhebi , son of 'Aḥmosi-mer(y)ptaḥ , both *khet*-priests of Ḥa, Prophets of Ptaḥ and Isis foremost of Thenent, etc., and Neityiti , IM.4033 [No. 398]. Text, CHASSINAT, op. cit. xxiii (1901), pp. 85-6 [cxlili].

Zeptaḥef'ankh , *sem*-priest, Secretary of Ra-setau, etc., son of Ḥekaemsaf  and Neferḥeres , IM.3999 [N.421/701; No. 446]. Text, id. ib. xxv (1903), p. 56 [clxx].

Zeptaḥef'ankh(?), God's father and Prophet of Ptaḥ, son of Amenemsaf , IM.4125 [No. 471]. Text, id. ib. xxv (1903), p. 59 [clxxvii].

. . . ḥotp, son of Haremnaḥkeru , probably year 34 of Darius I, IM.4087 [No. 390]. Text, id. ib. xxiii (1901), p. 83 [cxi].

. . . wep'au , Pefteu'aubaste, Treasurer of the King of Lower Egypt, etc., son of Mutardais, Sistrum-player of Ḥaḥor Mistress of the Southern Sycamore (mother), IM.4109. VERCOUTTER, *Textes*, pl. xi, pp. 78-81.

Name lost, son of Psammethek-snefertau  and Setyerboni, IM.4214. Names, LIEBLEIN, *Dict.* No. 1208.



Name lost, N.421/347 [S.N.31; No. 374]. Text, CHASSINAT, op. cit. xxiii (1901), p. 81 [cxxxvi].

In Cairo Museum.

Lower part of stela, CG 50042. SPIEGELBERG, *Die demotischen Denkmäler*, iii, *Demotische Inschriften und Papyri*, Taf. x, p. 13.

Temp. Darius I, probably year 34. In Louvre.

'Aḥmosi, God's father, Scribe, N.421/382 [S.N.64; No. 404]. Text, CHASSINAT in *Rec. Trav.* xxiii (1901), pp. 87-8 [cxlviii] (as year 34); see REVILLOUT, *Cat.* No. 533.

Ḥory, God's father and Prophet of Harsaphes in the domain of the Temple of Sekhmet, son of 'Aḥmosi-men , Iračəḥeka, Greatest of the Directors of craftsmen, and Sekhmetnefert , IM.4038 [N.421/614].

Ptaḥhotp, Overseer of the House of Silver and of the House of Gold, *khet*-priest of Ḥa, etc., IM.1244 [N.677]. Text, CHASSINAT, op. cit. xxi (1899), pp. 67-8 [xxvii]; see COONEY in *Brooklyn Mus. Bull.* xv [2] (Winter 1953), p. 14; BOTHMER, *Eg. Sculp.* p. 77; PIERRET, *Cat.* No. 327.

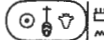

Probably temp. Darius I, year 34. In Louvre.

'Aḥmosi-men , Greatest of the Directors of craftsmen, etc., son of Nekau-

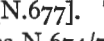
mer(y)ptaḥ  and grandson of Neferebrē-men , IM.4213 [No. 485]. Genealogy, BRUGSCH, *Thes.* 947 [13], cf. 1256; LIEBLEIN, *Dict.* No. 2515.

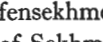
Amenḥotp, son of Psammethēk and Setyerboni , IM.4011 [N.677]. Text, CHASSINAT in *Rec. Trav.* xxi (1899), p. 64 [xix]; see PIERRET, *Cat.* No. 313 (as N.674/7011).

‘Ankhefensekhmet , son of Psammethēk, both Secretaries of the Great Place, Prophets of Sekhmet Mistress of Shendi, etc., and Setyerboni, IM.4080 [No. 219]. Text, CHASSINAT, op. cit. xxii (1900), pp. 25–6 [lxxviii] (as S.4080); names and titles, LIEBLEIN, *Dict.* No. 1205.

‘Ankhefensekhmet, *warb*-priest of the Temples of Memphis, etc., son of Neferseshem-psammethēk  Overseer of *warb*-priests of Sekhmet of the Temple of Ptaḥ, Prophet of the Temple of Merneptaḥ, etc., and Te(nt)nefertem , IM.4111.

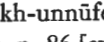
‘Ankh-unnūfer  IM.4060 [N.421/383; No. 399]. Text, CHASSINAT, op. cit. xxiii (1901), p. 86 [cxliv].

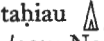
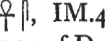
Diptahiau  son of Pedēsi, both God’s fathers, and ‘Ankhes , IM.4029 [N.421/397; No. 421]. Text, id. ib. xxv (1903), pp. 50–1 [clviii] (as Apis of year 34 of Darius I); names and titles, LIEBLEIN, *Dict.* No. 1033.

Diptahiau, son of ‘Ankh-unnūfer, God’s father, and Takap  IM.4056 [N.421/366; No. 405]. Text, CHASSINAT, op. cit. xxiii (1901), p. 88 [cxlix].

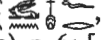

Diptahiau, son of Ptaḥḥotp and Takap, IM.4077.

Esbanebded, son of Shedsunefertem and Irterau, probably from here or year 31, although said to have been found in burial chamber of Apis XLI, IM.5341.

Espakhutai  son of Esunnūfer , both Prophets of Ptaḥ, etc., IM.4099 [N.679]. Text, CHASSINAT, op. cit. xxi (1899), p. 60 [vii]; see PIERRET, *Cat.* No. 294.

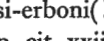
Ḥardedef  son of Pefteu‘aubaste, God’s father, IM.4050.

Ḥarem . . . ḥotp  son of Thešēsi-erboni(?)  (mother), IM.4149 [N.421/390; No. 406]. Text, CHASSINAT, op. cit. xxiii (1901), pp. 88 [cl].

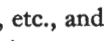

Ḥepmen  son of Esbanebded, both *wrrw*-priests, and Khredu‘ankh , IM.4121 [N.677]. Text, id. ib. xxi (1899), p. 69 [xxxii]; ČERNÝ Notebook, 117, p. 10 [lower]; see PIERRET, *Cat.* No. 686.



Ḥor, Overseer of the fields, Prophet of many gods, etc., son of Uzaḥorresnet  Royal scribe, etc., and Shepensopdet  C 317 [No. 428]. Text, CHASSINAT, op. cit. xxv (1903), pp. 52–3 [clxiii]; see BOREUX, *Guide*, i, p. 174.

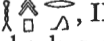

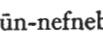
Imḥōtep, son of Setyerboni (mother), IM.4025 [N.421/366; No. 383]. Text, CHASSINAT, op. cit. xxiii (1901), p. 82 [cxxxviii]; ČERNÝ Notebook, 117, p. 4 [lower]; see REVILLOUT, *Cat.* No. 532.

Imḥōtep, son of Ptaḥardais and Tadēsi, IM.4120 [N.421/697; No. 470]. Text, CHASSINAT, op. cit. xxv (1903), p. 58 [clxxvi].



Imḥōtep, son of Ḥeperiu  IM.4134 [N.421/598; No. 472]. Text, id. ib. xxv (1903), p. 59 [clxxviii]; ČERNÝ Notebook, 117, p. 20 [upper] (as IM.4130).

Inamūn-nefnebu  Neferebrē-sineit , son of Ḥekaiotef , IM.4003 [N.421/393; No. 407]. Text, CHASSINAT, op. cit. xxiii (1901), p. 88 [cli].



Iḥardai[s]  son of Pair[kap](?) , N.421/593 [S.N.55; No. 444]. Text, id. ib. xxv (1903), p. 55 [clxviii]; see REVILLOUT, *Cat.* No. 547.

Khnebrē  Director of the estates, *wrrw*-priest, etc., son of Psammethēk-sineit , Chief lector-priest, and Setyerboni, IM.4032 [No. 410]. VERCOUTTER,



Textes, pl. xiii, pp. 88–92; WILKINSON MSS. xxiv. 17 [right]. Text, CHASSINAT, op. cit. xxiii (1901), pp. 89–90 [cliv]; main text, BRUGSCH, *Thes.* 989 [8, a]. Names and titles, LIEBLEIN, *Dict.* No. 1216. See REVILLOUT, *Cat.* No. 535.

Mem , son of Pawen , both God's fathers, *sem*-priests, etc., and Tayirterau , IM.4027 [N.421/403; No. 409]. Text, CHASSINAT, op. cit. xxiii (1901), p. 89 [cliii]; ČERNÝ Notebook, 117, p. 14 [bottom]; part, GOODWIN MSS. 31279, 34. Names and titles, LIEBLEIN, *Dict.* No. 1048. See REVILLOUT, *Cat.* No. 534.





Pashenptah(?), son of Ḥor, IM.4052 [N.481]. Text, CHASSINAT, op. cit. xxv (1903), p. 62 [clxxxii].



Pashenptah, son of Painmu , God's father, *sem*-priest, and Sopdetiyt , IM.4069.





Pedeḥor, son of Pedeḥarpekhrod, IM.4004.

Pedes , son of Senbef , both *sem*-priests, *wṗ-nṯrw*y, etc., IM.4001 [N.421/704; No. 474]. Text, CHASSINAT, op. cit. xxv (1903), p. 61 [clxxx].



Pedēsi, son of Ḥarwoz, IM.4169 [N.421/398; No. 463]. Text, id. ib. xxiii (1901), p. 87 [cxlvii].



Pedusiriwēr-nūfer , Door-opener of the Temple of Serapis, son of Pakap   and Hetepubaste , IM.4150 [N.421/394; No. 402]. Text, id. ib. xxiii (1901), p. 87 [cxlvi].



Pefteu'aukhons, Prophet of Amen-rē Lord of Khentnūfer, etc., son of Semtu-tefnakht  and Takapu , mentioning family with titles of Prophets of (a) a temple () of Ramesses II, (b) Sekhmet of Saḥurē, IM.4107 [N.421/399; No. 413]. Text, id. ib. xxiii (1901), pp. 90–1 [clv]; WILKINSON MSS. xxiv. 17 [left upper]; names and titles, LIEBLEIN, *Dict.* No. 1217.

Psammethek, son of Khnemebrē-siptah   Nekau , Greatest of the Directors of craftsmen of Ptaḥ, etc., and Ēsireshti , IM.4098 [No. 391]. Text, CHASSINAT, op. cit. xxiii (1901), pp. 83–4 [cxli].

Psammethek-ib(?) , Door-opener of Serapis, etc., IM.3047.



Psammethek-menempe , Prophet of Isis Mistress of the Pyramid, Khufu, Raʿzedef, Khephren, and Ḥaremakhet, son of Ḥarwoz and Taremtenubaste , IM.2857 [N.444; No. 291]. Text, CHASSINAT, op. cit. xvii (1895), pp. 53–4 [iv]; xxii (1900), pp. 173–4 [cxi]; WILKINSON MSS. xxiv. 25 [right upper]; see PIERRET, *Cat.* No. 314.

Ptaḥemmaʿkheru  Esptah , son of Ḥor, both *sem*-priests, Secretaries of Ra-setau, etc., IM.137 [No. 401]. Text, CHASSINAT, op. cit. xxiii (1901), pp. 86–7 [cxlvi]; name and titles, LIEBLEIN, *Dict.* 1231.

Semtu-tefnakht , *sem*-priest, etc., son of Irenḥor , IM.138 [N.421/647; No. 448]. Text, CHASSINAT, op. cit. xxv (1903), p. 57 [clxxii] (as IM.198).

Semtu-tefnakht, Director of the estates, Prophet of Harsaphes, etc., son of ʿAḥmosi-men, Greatest of the Directors of craftsmen, etc., and Sekhmetnefert, IM.4044 [N.677]. Text, id. ib. xxi (1899), p. 66 [xxiv]; see PIERRET, *Cat.* No. 324.

Semtu-tefnakht, son of Zeḥo, both God's fathers, *wṗrw*-priests, and ʿAnkh-irterau , IM.4095 [N.421/660; No. 445]. Text, CHASSINAT, op. cit. xxv (1903), pp. 55–6 [clxix].

Senbef , son of Pedes , both God's fathers, and Ēsireshti , IM.42 [N.421/626; No. 441]. Text, id. ib. xxv (1903), p. 54 [clxv] (as N.421/624).

Sinebʿankh , son of Zeptaḥefʿankh, IM.4190.

Weḥebrēt-mer(y)neit ♂ , IM.4055.

Zehō Shedneferterem, *sem*-priest, *wnrw*-priest in Letopolis, etc., son of Nubiyti  (mother), IM.4021.

Zeubastefankh , son of Pedēsi and Irterau, IM.4000 [N.421/676; No. 447]. Text, *id. ib.* xxv (1903), p. 56 [clxxi].

UNNUMBERED APIS. Year 2 of Nepheritis I.

Stelae. In Louvre.



Dated.

IM.4092 [No. 451]; see REVILLOUT, *Notice des papyrus démotiques archaïques* [etc.], pp. 470-1 [123].

IM.4101 [No. 458]; text, DEVÉRIA squeezes, 6165, i. 60-1; see REVILLOUT, *op. cit.* pp. 469-70 [122].

Hor, God's father, *sem*-priest, son of Pawen , IM.4103 [N.421/564]; text of probably this, DEVÉRIA squeezes, 6170D, 18; date and cartouches, VERCOUTTER, *Textes*, p. 100.

Probably year 2 of Nepheritis I.

Name lost, son of Paheter , Overseer of prophets, and Tairterau  IM. 4114. *Id. ib.* pl. xv, pp. 100-4.

APIS XLVI of Mariette. Year 2 of Khebebesh.

Chamber D' of Mariette, O of Rhoné.

Text on lid of black granite sarcophagus, with date, BRUGSCH, *Thes.* 968 [3]; *id.* in *Ä.Z.* ix (1871), p. 13; GUNN in *Ann. Serv.* xxvi (1926), p. 87; DEVÉRIA squeezes, 6165, i. 55; WILKINSON MSS. xviii. 42 [upper left]; xxiv. 6 [right top].

APIS LV of Mariette. Year 17 of Ptolemy VI Philometor.

Chamber P (2nd on right) of Rhoné.

Official stela, year 6 of the three Philometors (*i.e.* Ptolemies VI and VIII and Cleopatra II), giving the date of birth of the Apis-bull as year 19 of Ptolemy V Epiphanes, granite, in Louvre, N.409 (upper part) and E.3866 (lower part). ARCHIVES phot. E.982; DEVÉRIA squeezes, 6165, i. 68, and 6168, 29; text, BRUGSCH in *Ä.Z.* xxii (1884), p. 125; names, *id. Thes.* 865 [middle].

APIS LVII of Mariette. Year 52 of Ptolemy VIII Euergetes II.

Official stela, giving the date of birth of the Apis-bull as year 28 and death as year 51, black granite, in Louvre, IM.4246 [N.410]. ARCHIVES phot. E.983; DEVÉRIA squeezes, 6165, i. 69 and 6196, 17; text, DE ROUGÉ in *Revue Égyptologique*, iv (1887), pp. 110-18, and v (1888), pp. 8-9 (repr. in *Bibl. Ég.* xxii, pp. 424-38, 454-6); WILKINSON MSS. xxiv. 4 [right], 18; lines 2-3, BRUGSCH, *Thes.* p. 867 [upper]. See DE ROUGÉ, *Notice sommaire* (1876), p. 62.

APIS OF AN UNKNOWN PTOLEMY (?).

Chamber R of Rhoné.

Sarcophagus with lid, inscribed, black granite. DÜMICHEN, *Photo. Result.* xiv; PETRIE in WRIGHT, *Twentieth Century Impressions of Egypt*, fig. on p. 132 [upper]; CAPART, *Propos*, fig. 141; DESROCHES-NOBLECOURT, *Les Religions égyptiennes in L'Histoire générale des religions*, fig. on p. 224 [lower]; WOOD and DROWER, *Egypt in Colour*, pl. 11; LAUER, *Saqqara*, pl. 12; RUFFLE, *Heritage of the Pharaohs*, fig. 135. Texts, GUNN in *Ann. Serv.* xxvi (1926), pp. 88-90; WILKINSON MSS. xviii. 38-40.

APIS-STELAE NOT ASSIGNED TO A PARTICULAR APIS-BULL



In Louvre

Probably Dyn. XXII.

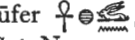

‘Ankh-ḥor , adoring, IM.2865 [N.679]. MALININE [etc.], *Cat.* i, pl. xxiii [80], p. 68; text, CHASSINAT in *Rec. Trav.* xxi (1899), p. 60 [vi]; see PIERRET, *Cat.* No. 291.

‘Ankh-khons , *imy-hnt*, IM.2849 [No. 94]. MALININE [etc.], *Cat.* i, pl. xx [66], p. 59.

‘Ankh-unnüfer , IM.3107 [S.1093; No. 33]. Id. ib. i, pl. xvii [55], p. 51; see REVILLOUT, *Cat.* No. 409.



‘Ashökhi , God's father, *sem*-priest in the Temple of Sokari Lord of Ra-setau, son of Pakhar , same titles, with long genealogy, IM.3429 [No. 96]. MALININE [etc.], *Cat.* i, pl. xvi [52], pp. 48-9; MARIETTE, *Sérapéum*, pl. 34 [bottom left] (as Dyn. XXIV); text, CHASSINAT in *Rec. Trav.* xxii (1900), pp. 16-17 [liv]; genealogy, LIEBLEIN, *Dict.* No. 1027; end of text, BRUGSCH, *Thes.* 1012 [bottom]; SOTTAS, *La Préservation de la propriété funéraire* [etc.], p. 167 [top]; see REVILLOUT, *Cat.* No. 440.

Ḥarsiēsi, son of Ḥarwoz(?), IM.3032 [S.2914; No. 32]. MALININE [etc.], *Cat.* i, pl. xxi [71], pp. 62-3; see REVILLOUT, *Cat.* No. 408.

Ḥarwoz , *warb*-priest of the Great Place, etc., son of Ten-tho  (woman), IM.5937 [No. 19]. MALININE [etc.], *Cat.* i, pl. xviii [59], pp. 53-4; some names and titles, LIEBLEIN, *Dict.* No. 1197; see REVILLOUT, *Cat.* No. 402.



Ḥarwoz-paḥeka , IM.3059 [N.421/38; No. 44]. MALININE [etc.], *Cat.* i, pl. xix [64], pp. 57-8; text, ČERNÝ Notebook, 117, p. 12 [upper].

Ḥepiu , IM.19 [No. 93]. MALININE [etc.], *Cat.* i, pl. xxv [87], p. 72; see REVILLOUT, *Cat.* No. 438.



Ḥerenḥepu , son of Pashenmut , IM.4215 [S.1951; No. 89]. MALININE [etc.], *Cat.* i, pl. xix [62], p. 56; see REVILLOUT, *Cat.* No. 434.

Ḥor, Head of door-openers of the Temple of Ptaḥ, S.N.58 [No. 53]. MALININE [etc.], *Cat.* i, pl. xxvi [90], pp. 74-5.

Irneferenptah , Craftsman, IM.3093 [S.1890; No. 27]. Id. ib. i, pl. xv [47], pp. 44-5.

Merneptah , Prophet of the Temples of Bubastis and Shesmetet (both called Mistress of ‘Ankhtai), etc., son of Esunnüfer , *sem*-priest, and his son Ptaḥhotp, God's father, *sem*-priest, etc. (owner of stela IM.3024, see *infra*), IM.3745 [N.421/63; No. 41]. Id. ib. i, pl. xvi [50], pp. 46-7; MARIETTE, *Sérapéum*, pl. 33 (as Apis VII of Dyn. XXII); VERCOUTTER, *Textes*, pl. i, pp. 1-15 [A]; text, CHASSINAT in *Rec. Trav.* xxii (1900), pp. 12-13 [xli].

Mes-unnüfer , IM.3311 [No. 69]. MALININE [etc.], *Cat.* i, pl. xxiv [83], p. 70; see REVILLOUT, *Cat.* No. 426.



Na'su , Head of the servants of Apis, son of Ḥatneferu , same title, IM.3081 [N.421/94; No. 99]. MALININE [etc.], *Cat.* i, pl. xvii [53], p. 49; see REVILLOUT, *Cat.* No. 442.

Pa'azab , *warb*-priest of the Great Place, son of Ḥarwoz, same title (owner of stela IM.5937, see *supra*), IM.3141 [No. 95]. MALININE [etc.], *Cat.* i, pl. xx [67], pp. 59–60; see REVILLOUT, *Cat.* No. 439.

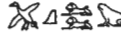
Paḥethi(?) , Workman of the Necropolis, IM.3033 [N.421/37; No. 60]. MALININE [etc.], *Cat.* i, pl. xxi [72], p. 63; text, CHASSINAT in *Rec. Trav.* xxii (1900), p. 14 [xlvi]; see REVILLOUT, *Cat.* No. 421.

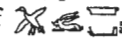

Paḳerer , son of Pashenptaḥ, IM.3065 [No. 25]. MALININE [etc.], *Cat.* i, pl. xxi [69], p. 61.



Pashensekhmet , son of Ptaḥhotp, God's father, *sem*-priest, IM.5432 [S.1895; No. 23]. *Id. ib.* i, pl. xxiv [84], pp. 70–1.

Pawenḥetef , Workman of the Necropolis, son of Paweredu , and others, IM.3083 [N.421/48; No. 47]. *Id. ib.* i, pl. xviii [60], pp. 54–5; text, CHASSINAT in *Rec. Trav.* xxii (1900), pp. 13–14 [xliii]; some names and titles, LIEBLEIN, *Dict.* No. 1017.

Pedekherbek . . . , son of Pedēsi, IM.3103 [N.679]. MALININE [etc.], *Cat.* i, pl. xxv [85], p. 71; text, CHASSINAT in *Rec. Trav.* xxi (1899), p. 68 [xxix]; see PIERRET, *Cat.* No. 332.

Pedēsi, God's father, Inspector of *sem*-priests, before Amen-rē, bull-headed Apis, Ptaḥ and Sokari-Osiris at top, much effaced, S.N.2 [No. 17]. MALININE [etc.], *Cat.* i, pl. xvii [54], pp. 50–1.

Pedesopdu , son of Pe(n)tent-khebi , IM.3128 [N.421/46; No. 65]. *Id. ib.* i, pl. xix [63], pp. 56–7; see REVILLOUT, *Cat.* No. 425.

Pefteu'aukhons , son of Ḥarma'kheru , God's father, with sides in form of obelisks and pyramidion in centre, IM.3008 [N.421/74; No. 81].¹ MALININE [etc.], *Cat.* i, pl. xxi [70], pp. 61–2; MARIETTE, *Sérapéum*, pl. 32 [lower left] (as Apis VII of Dyn. XXII); see REVILLOUT, *Cat.* No. 429.

Penptaḥ , son of Esunnüfer , IM.3305 [N.421/64; No. 73]. MALININE [etc.], *Cat.* i, pl. xix [61], p. 55; see REVILLOUT, *Cat.* No. 427.



Ptaḥhotp, Singer of the Temple of Ptaḥ, IM.3051 [N.421/65; No. 74]. MALININE [etc.], *Cat.* i, pl. xv [48], p. 45.

Ptaḥhotp (stela of father Merneptaḥ, IM.3745, see *supra*), IM.3024 [No. 295]. *Id. ib.* i, pl. xv [51], pp. 47–8; MARIETTE, *Sérapéum*, pl. 35 [middle] (as Apis II of Dyn. XXV).

Ptaḥhotp, inscribed on both sides, IM.2660. MALININE [etc.], *Cat.* i, pl. xxv [88], p. 73.

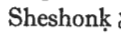
Ptaḥ-kha' , son of Wenemdi-amün , IM.2637 [S.1903; No. 26]. *Id. ib.* i, pl. xviii [58], p. 53; see REVILLOUT, *Cat.* No. 404.

Sheshonḳ , and father Pedeamün, IM.3016 [N.421/16; No. 52]. MALININE [etc.], *Cat.* i, pl. xv [49], pp. 45–6; MARIETTE, *Sérapéum*, pl. 25 [2] (as Apis III of Dyn. XXII); see REVILLOUT, *Cat.* No. 417.

Taped , Head of *kr* of Upper and Lower Egypt, daughter of Puerem , , Commander of the army, libating before Apis-bull, IM.3088 [No. 82]. MALININE [etc.], *Cat.* i, pl. xxiii [79], pp. 67–8; MARIETTE, *Sérapéum*, pl. 32 [upper right]; text,



¹ Modern copy formerly in Paris, Mus. Guimet, Inv.2494, now in Louvre, E.19993; MORET, *Catalogue du Musée Guimet. Galerie égyptienne in Annales du Musée Guimet*, xxxii (1909), pl. xlix, pp. 111–12.

CHASSINAT in *Rec. Trav.* xxii (1900), p. 15 [1]; some names and titles, LIEBLEIN in *Rev. Arch.* n.s. xviii (1868), p. 290 [bottom]; id. *Dict.* No. 1018; see REVILLOUT, *Cat.* No. 430.

Uzahor , Door-opener of Ptaḥ, IM.3426 [N.421/57; No. 70]. MALININE [etc.], *Cat.* i, pl. xxii [76], pp. 65–6.

Uzahor , IM.3101 [N.677]. Id. ib. i, pl. xxv [86], p. 72; see PIERRET, *Cat.* No. 329.

Uzarenu(?) , IM.3302 [No. 268]. MALININE [etc.], *Cat.* i, pl. xvii [56], p. 52; see CHASSINAT in *Rec. Trav.* xxii (1900), pp. 171–2 [cv].

Zeptaḥefankh , Head of craftsmen, son of Nana , IM.3123 [N.421/1; No. 88]. MALININE [etc.], *Cat.* i, pl. xxvi [89], pp. 73–4; text, CHASSINAT in *Rec. Trav.* xxii (1900), p. 16 [liii]; see REVILLOUT, *Cat.* No. 433.

. . . iau , IM.3060 [No. 66]. MALININE [etc.], *Cat.* i, pl. xxii [75], p. 65.



Several names, top missing, IM.2821 [S.2928; No. 49]. Id. ib. i, pl. xx [65], p. 58; see REVILLOUT, *Cat.* No. 415.

Man (name uncertain), IM.3022 [N.421/59]. MALININE [etc.], *Cat.* i, pl. xxiv [81], p. 69.

Man (no name), IM.38 [N.421/606]. Id. ib. i, pl. xviii [57], p. 52; see CHASSINAT in *Rec. Trav.* xxv (1903), p. 62 [clxxxii]; REVILLOUT, *Cat.* No. 566.

Dyn. XXII–XXV.

Year 4 of an unidentified King.

Ḥarwoz , son of Usirinakht , IM.3440 [No. 43]. MALININE [etc.], *Cat.* i, pl. xxxvi [129], p. 103; MARIETTE, *Sérapéum*, pl. 29 [lower right] (as Apis V of Dyn. XXII). Text, CHASSINAT in *Rec. Trav.* xxii (1900), p. 13 [xliv]. Date, see VERCOUTTER in *Kush*, viii (1960), p. 68 with note 36.

Pedusiri, with bull-headed Apis, IM.3019 [S.2661; No. 111]. MALININE [etc.], *Cat.* i, pl. xxxvi [130], p. 104.

Tha-amenemwēset , probably year 4, IM.3146 [N.421/31; No. 56]. Id. ib. i, pl. xxxvi [131], pp. 104–5.

Year 14 of an unidentified King.

Pef . . . , Door-opener of the Temple of Ptaḥ, IM.2686 [No. 28]. MALININE [etc.], *Cat.* i, pl. xxxiv [123], p. 98; VERCOUTTER in *Kush*, viii (1960), pl. xxii [a], p. 69 note 41; text, ČERNÝ Notebook, 117, p. 15 [bottom]; see REVILLOUT, *Cat.* No. 405.



Thaenkonsenimu , Door-opener of the Temple of Ptaḥ, no date but almost certainly contemporary with preceding stela, IM.3117 [S.1889; No. 22]. MALININE [etc.], *Cat.* i, pl. xxxv [124], p. 99; VERCOUTTER, op. cit. pl. xxii [b], p. 69 note 43.

Others.

‘Ankh-ḥor, IM.3100 [N.679]. MALININE [etc.], *Cat.* i, pl. xxxviii [136], p. 108; see CHASSINAT in *Rec. Trav.* xxi (1899), p. 59 [ii]; PIERRET, *Cat.* No. 283.

‘Ankh-ḥor, with two men with hoes at bottom, IM.3056 [N.421/51; No. 48]. MALININE [etc.], *Cat.* i, pl. xxxviii [139], p. 110; see REVILLOUT, *Cat.* No. 414.

‘Ankh-sheshonk , God’s father, son of Ḥarsiēsi, IM.3127 [No. 86]. MALININE [etc.], *Cat.* i, pl. xlii [151], p. 118; names, LIEBLEIN, *Dict.* No. 1024.

Ḥekaen . . . , son of Pueher , with man with basket before shrine with Apis-bull, IM.3025 [No. 51]. MALININE [etc.], *Cat.* i, pl. xxxviii [137], pp. 108–9; see REVILLOUT, *Cat.* No. 416.

Ḥepa’a , Judge, son of Ipu , IM.2631 [No. 195]. MALININE [etc.],

Cat. i, pl. xl [146], pp. 114–15; names, LIEBLEIN, *Dict.* No. 1053; see REVILLOUT, *Cat.* No. 465.

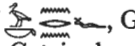
Ihy , son of Bekenrenef , God's father, etc., prostrate before Apis-bull, IM.2775 [No. 46]. MALININE [etc.], *Cat. i*, pl. xxxvii [132], p. 105; MARIETTE, *Sérapéum*, pl. 29 [upper right] (as Apis V of Dyn. XXII); names and titles, LIEBLEIN, *Dict.* No. 1047.

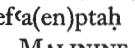
Iref'a(en)ptaḥ , *warb*-priest, Craftsman, unfinished, IM.3308 [N.421/97; No. 103]. MALININE [etc.], *Cat. i*, pl. xxxvii [135], p. 107; text, ČERNÝ Notebook, 117, p. 16 [lower]; see REVILLOUT, *Cat.* No. 444.

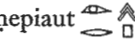
Irhepiauṯ , IM.2799 [No. 105]. MALININE [etc.], *Cat. i*, pl. xxxviii [138], p. 109.

Iry , son of Ptaḥemakhet(?) , S.N.52 [probably IM.3760; No. 173]. *Id. ib. i*, pl. xliii [157], p. 122; text, CHASSINAT in *Rec. Trav.* xxii [1900], p. 19 [lx]; see REVILLOUT, *Cat.* No. 458.

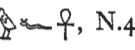
Iuiu , son of Iuf'ankh , N.421/52 [S.N.70; No. 68]. MALININE [etc.], *Cat. i*, pl. xliii [156], p. 121.

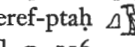
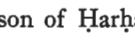
Ḳeref-ptaḥ , son of Ḳarḥap , S.N.16. *Id. ib. i*, pl. xli [148], p. 116.

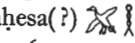
Paḥesa(?) , IM.3144 [N.677]. *Id. ib. i*, pl. xlii [153], pp. 119–20; see PIERRET, *Cat.* No. 296.

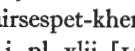
Pairsespet-khemac-amün(?) , IM.3133 [No. 84]. MALININE [etc.], *Cat. i*, pl. xlii [152], pp. 118–19; MARIETTE, *Sérapéum*, pl. 32 [upper left] (as Apis VII of Dyn. XXII). Text, CHASSINAT in *Rec. Trav.* xxii (1900), p. 15 [li]. See REVILLOUT, *Cat.* No. 432.

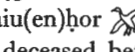
Paiu(en)ḥor , Door-opener of the Temple of Ptaḥ, son of Pashenēsi, with Isis and deceased before Apis-bull in shrine, IM.3439 [N.677]. MALININE [etc.], *Cat. i*, pl. xxxix [142], p. 112; see PIERRET, *Cat.* No. 282.

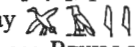
Pay , IM.3064 [N.421/44; No. 64]. MALININE [etc.], *Cat. i*, pl. xxxix [141], p. 111; see REVILLOUT, *Cat.* No. 424.

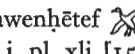
Pawenḥētef , God's father, IM.2717 [N.421/50; No. 67]. MALININE [etc.], *Cat. i*, pl. xli [150], p. 117.

Pedes , Judge, IM.4168 [No. 205]. *Id. ib. i*, pl. xl [144], p. 113. Text, CHASSINAT in *Rec. Trav.* xxii (1900), p. 23 [lxix] (as Apis I of Dyn. XXIV); ČERNÝ Notebook, 117, p. 1 [upper]. Names, LIEBLEIN, *Dict.* No. 1220. See REVILLOUT, *Cat.* No. 469.

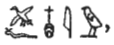
Pedēsi, prostrate before Apis-bull, with text of Pedēḥor(?), son of Pefneferiu , below, IM.2784 [No. 45]. MALININE [etc.], *Cat. i*, pl. xxxvii [133], p. 106.

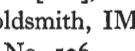
Pedēsi, son of Račmosi , Goldsmith, IM.3316 [N.421/321; S.2226]. *Id. ib. i*, pl. xl [145], p. 114; see REVILLOUT, *Cat.* No. 506.

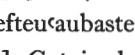

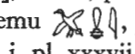
Pefteu'aubaste , kneeling before Apis-bull and Nephthys, No. 200. MALININE [etc.], *Cat. i*, pl. xli [147], p. 115; text, CHASSINAT in *Rec. Trav.* xxii (1900), p. 21 [lxv].

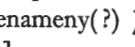
Pemu , prostrate before Apis-bull, IM.2809 [N.421/32; No. 57]. MALININE [etc.], *Cat. i*, pl. xxxvii [134], pp. 106–7; text, CHASSINAT, *op. cit.* xxii (1900), p. 14 [xliv].

Penameny(?) , S.N.60 [No. 55]. MALININE [etc.], *Cat. i*, pl. xxxix [140], p. 110; see REVILLOUT, *Cat.* No. 418.

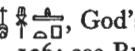
Ptaḥḥotp, son of Ḳor, *khet*-priest of Ḳa, etc., S.N.56 [No. 172]. MALININE [etc.], *Cat. i*, pl. xl [143], pp. 112–13.

Ptaḥḥotp, son of Nefertemḥotp , God's father, etc., IM.2782 [N.421/285; S.2222; No. 290]. *Id. ib. i*, pl. xlv [163], p. 126; see REVILLOUT, *Cat.* No. 498.

Ptaḥnakht , son of 'Ankhefensekhmet(?) , S.N.43 [No. 54]. MALININE [etc.], *Cat.* i, pl. xliii [155], pp. 120-1.

Ptaḥnūfer , son of 'Ankhpekhrod, IM.3587 [No. 24]. *Id. ib. i*, pl. xlii [154], p. 120; see REVILLOUT, *Cat.* No. 403.



Ptaḥwēr , Priest of the Temple of Ptaḥ, IM.3097 [N.677; S.1933]. MALININE [etc.], *Cat.* i, pl. xli [149], pp. 116-17; see PIERRET, *Cat.* No. 287.



Probably Dyn. XXV.



Amenardais, IM.3109 [No. 72]. MALININE [etc.], *Cat.* i, pl. xlv [166], p. 128.



Amenicaseb(?) , IM.3028 [S.2218; No. 310]. *Id. ib. i*, pl. xlvi [167], p. 129.

Bekenrenef , IM.3102 [N.677; S.2025]. *Id. ib. i*, pl. xlv [165], pp. 127-8; incomplete text, CHASSINAT in *Rec. Trav.* xxi (1899), p. 61 [xi] (as Dyn. XXIV); see PIERRET, *Cat.* No. 301.

Espekafai'a , son of Ḥepardais  and Irterau . (a) IM.3080 [S.2198; No. 242], MALININE [etc.], *Cat.* i, pl. xlvi [170], p. 131; text, CHASSINAT in *Rec. Trav.* xxii (1900), pp. 167-8 [xci]. (b) IM.2661 [S.2199; No. 292], MALININE [etc.], *Cat.* i, pl. xlvii [171], p. 132; text, CHASSINAT, *op. cit.* xxii (1900), p. 174 [cxii].

Esptah , son of Sekhmetka , both Overseers of the Necropolis, S.N.78 [No. 39]. MALININE [etc.], *Cat.* i, pl. xlvi [169], pp. 130-1; MARIETTE, *Sérapéum*, pl. 29 [upper left] (as Apis V of Dyn. XXII); names and titles, LIEBLEIN, *Dict.* No. 1201; see REVILLOUT, *Cat.* No. 413.

Ḥekaemhēt , son of Pedes , Prophet of Ptaḥ, IM.3030 [No. 215]. MALININE [etc.], *Cat.* i, pl. xlix [179], pp. 136-7; text, CHASSINAT in *Rec. Trav.* xxii (1900), pp. 24-5 [lxxvi] (as Apis V of Dyn. XXII); ČERNÝ Notebook, 117, p. 3 [lower].

Kemkap , son of Pedekherbek , IM.2762 [No. 187]. MALININE [etc.], *Cat.* i, pl. xlv [164], p. 127.

Pashensekhmet , IM.3058 [No. 246]. *Id. ib. i*, pl. xlix [180], pp. 137-8.

Pedes , IM.2672 [No. 102]. *Id. ib. i*, pl. xlvii [174], p. 134; texts, CHASSINAT in *Rec. Trav.* xxii (1900), p. 17 [lv] (as Apis VI of Dyn. XXII).



Pedubaste, son of Ḥarsīēsi, IM.3010 [No. 378]. MALININE [etc.], *Cat.* i, pl. xlviiii [176], p. 135; MARIETTE, *Sérapéum*, pl. 35 [right] (as Apis II of Dyn. XXV). Text, CHASSINAT in *Rec. Trav.* xxiii (1901), pp. 81-2 [cxxxvii]. See REVILLOUT, *Cat.* No. 531.

Shedsunefertem , son of Siptah (owner of stela IM.2785, see below), IM.2807 [S.2190; No. 214]. MALININE [etc.], *Cat.* i, pl. xlvii [173], p. 133; text, CHASSINAT in *Rec. Trav.* xxii (1900), p. 24 [lxxv] (as Apis I of Dyn. XXVI).

Siptah , Count, Prophet of Wert-ḥekau Mistress of the Palace, etc., IM.2785 [N.5442; S.2189; No. 439]. MALININE [etc.], *Cat.* i, pl. xlvii [172], pp. 132-3.

... amūn, son of 'Ankhpefheri , with Isis and Nephthys, IM.2795 [S.1888; No. 229]. *Id. ib. i*, pl. xlix [181], p. 138; text, CHASSINAT in *Rec. Trav.* xxii (1900), pp. 163-4 [lxxxii].

Dyn. XXV to early Dyn. XXVI.

Ḥarnakht  and Ḥarwoz, sons of Ptaḥhotp, God's father, and Khnemnūfer , IM.2724 [No. 223]. MALININE [etc.], *Cat.* i, pl. xliv [161], pp. 124-5; text, ČERNÝ Notebook, 117, p. 3 [upper]; names, LIEBLEIN, *Dict.* No. 1221; see REVILLOUT, *Cat.* No. 470.

Harwoz, Door-opener of Ptaḥ, IM.3116 [No. 20]. MALININE [etc.], *Cat.* i, pl. li [187], pp. 142-3.

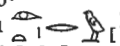
Irterau , Door-opener of Ptaḥ, son of 'Ankh-kh[ons], IM.3020 [No. 287]. *Id.* ib. i, pl. l [184], pp. 140-1; see REVILLOUT, *Cat.* No. 497.

Kha'suenēsi , son of Uzaḥor, IM.3139 [S.2083; No. 144]. MALININE [etc.], *Cat.* i, pl. lii [191], p. 145.

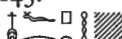
Nefer . . . ptaḥ , IM.3070 [No. 269]. *Id.* ib. i, pl. li [188], p. 143.

Paneḥesi , IM.2710 [N.421/150; S.2125; No. 154]. *Id.* ib. i, pl. xlii [162], p. 125.

Pede . . . (?) , S.N.48. *Id.* ib. i, pl. l [186], p. 142; text, ČERNÝ Notebook, 117, p. 1 [lower].

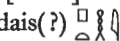
Ptaḥardais (?) , IM.4218 [S.1982; No. 92]. MALININE [etc.], *Cat.* i, pl. l [185], p. 141; see REVILLOUT, *Cat.* No. 437.

Ptaḥhotp, God's father, IM.3588 [No. 138]. MALININE [etc.], *Cat.* i, pl. li [190], pp. 144-5.

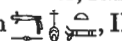
Shedsunefertem , IM.3586 [N.421/271; No. 280]. *Id.* ib. i, pl. li [189], p. 144; text, CHASSINAT in *Rec. Trav.* xxii (1900), p. 173 [cx] (as Apis IV of Dyn. XXII); see REVILLOUT, *Cat.* No. 495.

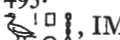
Siptaḥ , IM.3312 [S.2209; No. 329]. MALININE [etc.], *Cat.* i, pl. xlix [182], p. 139.

Wenptaḥ , IM.5949 [N.421/303; S.2216; No. 304]. *Id.* ib. i, pl. l [183], p. 140.

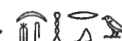
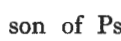

Dyn. XXVI.

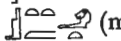

'Aḥmosi . . . , son of Psammethek-sirēc , both Charioteers, N.5442/4130 [S.2278]. Text, CHASSINAT in *Rec. Trav.* xxi (1899), p. 63 [xvii]; names and titles, LIEBLEIN, *Dict.* No. 1260; see PIERRET, *Cat.* No. 311.

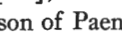
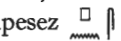
Amenḥotp, IM.3577 [S.2016].

'Ankh-ḥap, son of Ēsiemḥēt , (mother), N.677 [S.2211]. Text, CHASSINAT, *op. cit.* xxi (1899), p. 60 [viii]; see PIERRET, *Cat.* No. 295.

'Ash'ash , son of Paensupesez , IM.2860 [N.677]. Text, CHASSINAT, *op. cit.* xxi (1899), p. 62 [xiv] (as Apis V of Dyn. XXVI); see PIERRET, *Cat.* No. 306.

Dwensupanūfer , son of Ḥarwoz and Kha'sumin , IM.2864 [N.677]. Text, CHASSINAT, *op. cit.* xxi (1899), pp. 62-3 [xv] (as Apis V of Dyn. XXVI); ČERNÝ Notebook, 117, p. 10 [upper]; see PIERRET, *Cat.* No. 308.

Ḥaremma'kheru , son of Ḥarnakht , IM.3135.

Ḥarwoz, Prophet of HORUS, Noble (*srḥ*) of Ḥebnu, with Ptaḥ-Sokari and bull-headed Apis at top, IM.4065. VERCOUTTER, *Textes*, pl. xvii, pp. 109-12; text, ČERNÝ Notebook, 117, p. 6 [lower].

Imut , son of Zeamūnef'ankh, IM.2862 [S.2227, No. 226]. See REVILLOUT, *Cat.* No. 471.

I'oḥweben(?), God's father, IM.5941 [S.2085; No. 228]. See *id.* ib. No. 473.

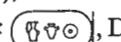
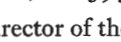
Khneṃbrēc , Director of the estates, *wnrw*-priest in Letopolis, etc., son of Uzaḥor-resnet and Pespermeḥ , IM.4193.

Neferebrēc-merryptaḥ , Prophet of the Ram of Mendes, dedicated by son

Weḥebrēc-mererptaḥ , same title, IM.4042. Text, WILKINSON MSS. xxiv. 7 [right lower]; names and titles, LIEBLEIN, *Dict.* No. 1213.

Neferseshem-psammethek , *warb*-priest of the Temples of Memphis, son

of Weḥbrēc-mer(y)ptaḥ $\textcircled{\text{𓆎}} \textcircled{\text{𓆏}} \textcircled{\text{𓆐}} \textcircled{\text{𓆑}} \textcircled{\text{𓆒}}$, *sem*-priest, Secretary of the Temple of Ptaḥ, etc., and Ēsiwert $\textcircled{\text{𓆓}} \textcircled{\text{𓆔}} \textcircled{\text{𓆕}}$, IM.4067 [N. 418; S.2254]. RICHER, *Le Nu*, fig. 155 [upper]; DEVÉRIA squeezes, 6165, ii. 107; ARCHIVES phot. E.570; deceased kneeling, GROSSET, *The Civilizations of the East*, i, fig. 44. Names and titles, LIEBLEIN in *Rev. Arch.* N.S. xviii (1868), pp. 274–5; id. *Dict.* No. 1207. See DE ROUGÉ, *Notice sommaire* (1876), p. 61.

Pedep $\textcircled{\text{𓆖}} \textcircled{\text{𓆗}}$, son of Pedepḥ, Prophet of Ptaḥ and Bubastis Mistress of ‘Ankhtau, and Neferheres $\textcircled{\text{𓆘}} \textcircled{\text{𓆙}}$, IM.3098 [No. 209]. Text, CHASSINAT in *Rec. Trav.* xxii (1900), pp. 23–4 [lxxii].

Pedes $\textcircled{\text{𓆚}} \textcircled{\text{𓆛}}$, Craftsman, IM.3111 [N.421/522; No. 321]. Text, id. ib. xxii (1900), p. 175 [cxv].

Pefteu‘aukhons $\textcircled{\text{𓆜}} \textcircled{\text{𓆝}} \textcircled{\text{𓆞}} \textcircled{\text{𓆟}} \textcircled{\text{𓆠}}$, IM.3096 [N.679]. Text, id. ib. xxi (1899), p. 65 [xxi]; see PIERRET, *Cat.* No. 317.

Psammethk, Greatest of the physicians of Upper and Lower Egypt, etc. (tomb, see *supra*, p. 649), perhaps temp. Amasis, IM.4084 [No. 338]. Text, CHASSINAT, op. cit. xxii (1900), pp. 177–8 [cxxii] (as Apis V of Dyn. XXVI); MASPERO in *Ann. Serv.* i (1900), p. 185 (by Chassinat); see REVILLOUT, *Cat.* No. 512.

Psammethk, God’s father, Prophet, N.421/12 [No. 260]. Text, CHASSINAT, op. cit. xxii (1900), pp. 170–1 [ci]; see REVILLOUT, *Cat.* No. 486.

Ptaḥhotp, Secretary of Ra-setau, Prophet of Amūn, etc., son of Pedēsi and Sit-ḥap $\textcircled{\text{𓆡}} \textcircled{\text{𓆢}}$, IM.4062 [N.421/328; No. 344]. Text, CHASSINAT, op. cit. xxii (1900), pp. 178–9 [cxxiv]; see REVILLOUT, *Cat.* No. 515.

Ptaḥnūfer, son of Diptahiau $\textcircled{\text{𓆣}} \textcircled{\text{𓆤}}$, IM.3136 [N.421; No. 306]. Text, ČERNÝ Notebook, 117, p. 13 [top]; see REVILLOUT, *Cat.* No. 499.

Uzahor, son of Dḥutardais, IM.2645 [S.2144; No. 189].

Weḥbrēc-unnūfer and Weḥbrēc-mer(y)ptaḥ $\textcircled{\text{𓆥}} \textcircled{\text{𓆦}} \textcircled{\text{𓆧}} \textcircled{\text{𓆨}}$, sons of Menkhib-weḥbrēc, and others, IM.4217 [N.421/339; No. 352]. Text, CHASSINAT, op. cit. xxiii (1901), p. 76 [cxxviii] (as Apis IV of Dyn. XXVI); see REVILLOUT, *Cat.* No. 522.

Weḥbrēc . . ., Inspector of *sem*-priests, etc., son of Sit-ḥap $\textcircled{\text{𓆩}} \textcircled{\text{𓆪}}$ (mother), IM.3095.

Zeptaḥefankh, *wnrw*-priest in Letopolis, etc., son of Sinūhet $\textcircled{\text{𓆫}} \textcircled{\text{𓆬}}$, IM.4189.

Zeptaḥefankh, Door-opener of the Temple of Ptaḥ, son of Tahert $\textcircled{\text{𓆭}} \textcircled{\text{𓆮}}$ (mother), probably temp. Psammetikhos I. Names and titles, LIEBLEIN, *Dict.* No. 1143.

Zeubastefankh, Royal scribe, son of Pedēsi and Irterau, No. 435 (probably).

Name uncertain, IM.2651 [N.421/307; No. 296].

Name lost, fragment, temp. Amasis (probably year 4 or 5), IM.4113. VERCOUTTER, *Textes*, pl. ii, pp. 16–26.

Dyn. XXVI–XXVII.

‘Ahmosi, Overseer of *wacḥ*-priests of Sekhmet, etc., son of Weḥbrēc-[mery]ptaḥ $\textcircled{\text{𓆯}} \textcircled{\text{𓆰}} \textcircled{\text{𓆱}}$, IM.4108.



‘Ahmosi, son of Weḥbrēc-ḥarenpe $\textcircled{\text{𓆲}} \textcircled{\text{𓆳}} \textcircled{\text{𓆴}}$, both Charioteers, and Setyerboni, IM.4126 [N.421/570; No. 449]. Text, CHASSINAT in *Rec. Trav.* xxv (1903), p. 57 [clxxiii]; see REVILLOUT, *Cat.* No. 549.



‘Ankhef(en)mut $\textcircled{\text{𓆵}} \textcircled{\text{𓆶}}$, God’s father, Secretary of Ra-setau, son of Senbef(?), Prophet of Amūn, and Tashensekhmet $\textcircled{\text{𓆷}} \textcircled{\text{𓆸}}$, IM.4089.

Diptahiau $\textcircled{\text{𓆹}} \textcircled{\text{𓆺}}$, God’s father, son of Pedēsi and ‘Ank-tes-ḥert $\textcircled{\text{𓆻}} \textcircled{\text{𓆼}}$ (?), IM. 5343 [N.421/344; No. 348]. Text, CHASSINAT, op. cit. xxii (1900), p. 179 [cxxv] (as Apis V of Dyn. XXVI); names and titles, LIEBLEIN, *Dict.* No. 1229.



Haremnet  β , God's father, *wrrw*-priest in Letopolis, IM.4079.



Imhōtep, Prophet of Serapis, etc., IM.4106.

Mer(y)ptah  β , *wrrw*-priest in Letopolis, Prophet of all the gods in Khanūfer, etc., son of Pashenptah, *wrrw*-priest, etc., and Mernubtiotes  β , IM.4030. VERCOUTTER, *Textes*, pl. xii, pp. 82-7 (as temp. Amasis, or more likely year 34 of Darius I); text, ČERNÝ Notebook, 117, p. 24 [lower].

Neferebrēt  β , son of Shedsunefertem  β , both *wp-ntrwy*, etc., IM.4119. One name and titles, JELÍNKOVÁ in *Ann. Serv.* lv (1958), p. 124 [96].

Pashenptah 'Ankh-ḥap, son of Esptah and Irterau, IM.4043 [N.421/605].

Shep(en)-ius'as  β , God's father, Prophet, son of Painmu  β and Sit-ḥap, IM.4020. Text, ČERNÝ Notebook, 117, p. 13 [bottom].

Weḥebre'c-mer(y)neit  β , Prophet of Ḥeḳet Mistress of Ḥerwēr and Nekhbet Mistress of Nekheb, Deputy of the Temple of Ptaḥ, etc., son of Uzaḥorresnet  β , Chief lector-priest, and Hert  β , Sistrum-player of Sekhmet, top part lost, IM.4112 [N.421/620; No. 473]. VERCOUTTER, op. cit. pl. xiv, pp. 93-9; text, CHASSINAT, op. cit. xxv (1903), pp. 59-61 [clxxxix] (as Apis of year 34 of Darius I).





Weḥebre'c-merypthah, Overseer of the Two Granaries, Overseer of scribes of the Great Prison, son of Irterau (mother), IM.4073 [N.421/324].

Weḥebre'c-nebpeḥti  β , son of Semtu-tefnakht, IM.4066.



Dyn. XXVII.



Fragment of official stela, IM.4198 [N.421/644]. VERCOUTTER in *Mitt. Kairo*, 16 (1958), Taf. xxxi, pp. 333-45 with fig. 1.

Ptolemaic.

'Aḥmosi, Prophet of the Sanctuary ( β) of Ramesses of the Temple ( β) of Memphis, Prophet of Sekhmet of the *mert* of Saḥur'c, etc., son of Herib  β and Tiamūn  β , temp. Ptolemy V Epiphanes, C 316 [No. 427]. Text, CHASSINAT in *Rec. Trav.* xxv (1903), pp. 51-2 [clxii]; OTTO in *Ä.Z.* 81 (1956), pp. 119-20 [1], cf. 109; see BOREUX, *Guide*, i, p. 174.



Ḍḥuti-herib  β , *warb*-priest of the Temples of Memphis, etc., IM.6.

Esnuwēr  β , *warb*-priest of the Temples of Memphis, Prophet of the statues of Nektanebos II in the Temple of the domain of Great Sekhmet 'at the head of the valley', etc., son of Unnūfer, Prophet of the statues of Nektanebos II in various temples, Prophet of Menes and Teti, etc., and Semsem  β , Sistrum-player of Anubis upon his mountain, temp. Ptolemy IV Philopator and V Epiphanes, IM.3689. DEVÉRIA squeezes, 6169, i. 46; text, CHASSINAT, op. cit. xxi (1899), pp. 69-70 [xxxii]; OTTO, op. cit. pp. 127-8 [10], cf. 110; some titles, see DE MEULENAERE in *Chron. d'Ég.* xxxv (1960), pp. 94-5 [6]; see PIERRET, *Cat.* No. 328.



Ḥepmeneḥ  β , son of Ḥarwoz and Renpet  β , hieroglyphic and demotic texts, IM.3345 [N.421/526]. Text, REVILLOUT in *Revue Égyptologique*, vi (1891), pl. 1 facing p. 104, cf. pp. 95-6 (as No. 59).

Itōḥ  β , IM.3717.

Irtharerau  β , S.N.1. WILKINSON MSS. xxiv. 36, with squeeze.

Thaiḥepimu  β , Door-opener of Apis, son of Irtaḥap  β , IM.4167.



Unnūfer, son of Pashentihet  β , hieroglyphic and demotic texts, IM.16. Text, REVILLOUT, op. cit. pl. 2 after p. 104, cf. pp. 97-8 (as No. 117).

Weḥebrē(em)khebi , Chief lector-priest, etc., son of Ḥarwoz and Ēsiwert , and others, S.N.79.

Name illegible, Prophet of the statues of Nektanebos II of the temple in the domain of Osiris Lord of Ra-setau, IM.176 [N.421/601]. Title, DE MEULENAERE, op. cit. p. 95 [7].



Procession of different aspects of Horus, and effaced text below, IM.3 [S.1006]. Short texts, ČERNÝ Notebook, 117, p. 6 [upper].

Date uncertain. Mostly Dyn. XXVI–XXX.

‘Aḥmosi, son of Uzaḥorresnet  both *wnrw*-priests in Letopolis, Prophets of Buto Mistress of Pe and Dep, Overseers of the town, etc., and Her(?)  , Sistrum-player of Neith Mistress of Sais, IM.4012. Text, ČERNÝ Notebook, 117, p. 9.





‘Ankh-ḥap, Prophet of Harpocrates, etc., son of Unnūfer, E.6246.



‘Ankhpefḥeri , IM.3758 [N.677].

‘Ath , *wnrw*-priest, son of Pakha  and Renpetnefert. Text, GOODWIN MSS. 31279, 30 [right]; names, LIEBLEIN, *Dict.* No. 1204.

Dḥutiptaḥ , God’s father, son of ‘Ankh-unnūfer, S.1889 [No. 235]. Text, CHASSINAT in *Rec. Trav.* xxii (1900), p. 165 [LXXXVII].



Diptaḥiau  and Imḥōtep, IM.3729.

Duarē , ‘Ankh-ḥor , son of Pefteu‘aubaste  and Meḥytwērtnebt‘ankh , IM.4135 [No. 143]. Text, id. ib. xxii (1900), p. 18 [lviii] (as S.4135).

Gemniḥarbak , *sem*-priest, Prophet of Ptaḥ, son of Neferebrē  and Shepenubaste , IM.4041 [No. 420]. Text, id. ib. xxv (1903), p. 50 [clvii]; see REVILLOUT, *Cat.* No. 537.

Ḥarbes , son of Pashenḥaṥor  and Irterau, IM.4083 [N.421/579].

Ḥaremḥab , Treasurer of the King of Lower Egypt, etc., son of ‘Ankh-ḥap, on *recto*, and Psammethek-sonb, Prophet of the statue of Amasis, etc., on *verso*, IM.4115. Name and title, JELÍNKOVÁ in *Ann. Serv.* lv (1958), p. 124 [98] (as Pasetemsonb).

Ḥarkhebi , son of Te(n)ṥap  (mother), IM.4071. See PIERRET, *Cat.* No. 293.

Ḥarmaḥkeru , [*wnrw*-priest] in Letopolis, etc., son of Weḥebrē . . . , N.421/698 [S.N.50].



Ḥarsiēsi, son of Sekhmetnefert (mother), IM.4082.

Ḥarsiēsi, son of Ḥekaemsaf , both God’s fathers, IM.4085 [N.421/613; No. 464]. Text, CHASSINAT, op. cit. xxv (1903), pp. 57–8 [clxxiv]; see REVILLOUT, *Cat.* No. 555.

Ḥarsiēsi, *wnrw*-priest in Letopolis, etc., son of Psammethek. Names and titles, LIEBLEIN, *Dict.* No. 1209.

Ḥor, son of Thesubastepert , IM.3145 [No. 327].

Ḥor, God’s father, *wnrw*-priest in Letopolis, IM.4015. One name, JELÍNKOVÁ, op. cit. p. 124 [91].

Irḥaḥor , son of Pairkap  Psammethek-[meryneit], both God’s fathers, Directors of the estates, etc., S.N.47. Text, ČERNÝ Notebook, 117, p. 23 [lower]; name and two titles, JELÍNKOVÁ, op. cit. p. 124 [97] (as Ir‘a).

Kanūfer , son of Tutu-imḥōtep , IM.4075 [N.421/662; No. 442]. Text, CHASSINAT, op. cit. xxv (1903), p. 54 [clxvi].

Kha'emwëset, son of Pemu $\square \text{𓂏} \text{𓂏}$ and Sit-ḥap'ankh $\text{𓂏} \text{𓂏} \text{𓂏} \text{𓂏} \text{𓂏} \text{𓂏} \text{𓂏}$, IM.129 [N.421/658]. See PIERRET, *Cat.* No. 311 bis.

Nefarud $\text{𓂏} \text{𓂏} \text{𓂏} \text{𓂏} \text{𓂏}$, son of Perka $\square \text{𓂏}$, IM.5427 [S.4045; No. 251]. Text, CHASSINAT, op. cit. xxii (1900), pp. 169–70 [xcvii]; names, LIEBLEIN, *Dict.* No. 1226; see REVILLOUT, *Cat.* No. 484.

Nekhten . . . $\text{𓂏} \text{𓂏} \text{𓂏}$, IM.4122 [N.421/404; No. 423]. Text, CHASSINAT, op. cit. xxv (1903), p. 51 [clix]; see REVILLOUT, *Cat.* No. 538.

Painmu $\text{𓂏} \text{𓂏}$, God's father, Prophet, IM.4216 [N.677; No. 204]. Text, CHASSINAT, op. cit. xxii (1900), p. 22 [lxviii] (as N.677/4210); see PIERRET, *Cat.* No. 288.

Pakap $\text{𓂏} \text{𓂏}$, son of Ptaḥhotp, IM.4191.

Pashenptaḥ, God's father, *sem*-priest, etc., son of Ḥaremakhēt $\text{𓂏} \text{𓂏} \text{𓂏}$, IM.4026. Names and titles, LIEBLEIN, *Dict.* No. 1234.

Pashenptaḥ, son of Mer(y)ptaḥ $\text{𓂏} \text{𓂏}$, both God's fathers, *wnrw*-priests in Letopolis, and Khedeb-yerboni, IM.4117. Text, WILKINSON MSS. xxiv. 17 [lower].

Pashe(n)sekhmet-ankh-ḥeka(?) $\text{𓂏} \text{𓂏} \text{𓂏} \text{𓂏} \text{𓂏}$, IM.4210 [N.421/648]. See PIERRET, *Cat.* No. 318.

Pashentiḥet $\text{𓂏} \text{𓂏}$, *wp-ntrwy*, Prophet of Buto Opener of the Ways, etc., son of 'Ankh-ḥap, IM.3732.

Pashentiḥet, son of Pemu $\square \text{𓂏} \text{𓂏}$ and Ēsireshti $\text{𓂏} \text{𓂏}$, IM.4005 [No. 425]. Text, CHASSINAT, op. cit. xxv (1903), p. 51 [clxi]; names and titles, LIEBLEIN, *Dict.* No. 1032.

Pedubaste, son of Pedenefertem $\square \text{𓂏} \text{𓂏}$, both God's fathers, *sem*-priests, etc., No. 78. Text, ČERNÝ Notebook, 117, p. 11 [lower].

Pefteu'auësi, God's father, Secretary of Ra-setau, son of Painmu, IM.4123.

Pefteu'aukhons, son of Shepenubaste, IM.47 [N.421/473; S.993].

Psammethēk, son of 'Ankh-(the)kerti $\text{𓂏} \text{𓂏} \text{𓂏}$ and Tathenef $\text{𓂏} \text{𓂏}$, IM.4010.

Psammethēk-sonb, son of Pedenebwen $\text{𓂏} \text{𓂏}$ and Irterau, IM.4047.

Psammethēk-sonb, *fkt*-priest of the Temple of Ptaḥ, son of Neferebrēc-[mery]ptaḥ $\text{𓂏} \text{𓂏} \text{𓂏}$, with Zēḥo, *fkt*-priest of the Temple of Ptaḥ, IM.4105. Some names and titles, JELÍNKOVÁ in *Ann. Serv.* lv (1958), p. 124 [92–5].

Ptaḥhotp, IM.36.

Ptaḥhotp, son of Ptaḥwēr and Mery(t)ptaḥ, IM.43.

Ptaḥhotp, God's father, *sem*-priest, son of Esunnūfer, IM.3431.

Ptaḥhotp and brothers, sons of Sekhmetardais $\text{𓂏} \text{𓂏} \text{𓂏}$ (mother), S.N.62. Text, ČERNÝ Notebook, 117, p. 2 [lower].

Ptaḥhotp, son of Neferḥōtep, God's father, etc. Names and titles, LIEBLEIN, *Dict.* No. 1206.

Ptaḥwēr, son of Esbanebdeḏ, both God's fathers, *wp-ntrwy*, etc., IM.4127 [No. 408]. Text, CHASSINAT, op. cit. xxiii (1901), p. 89 [cli].

Senbef, IM.37.

Senbef, son of Ptaḥhotp, IM.3040. Names, LIEBLEIN, *Dict.* No. 1227.

Shedsunefertem $\text{𓂏} \text{𓂏} \text{𓂏}$, God's father, *wp-ntrwy*, etc., son of Ptaḥhotp, God's father, IM.4091. Names and titles, id. ib. No. 1228.

Thaiḥepimu $\text{𓂏} \text{𓂏}$, Door-opener of Serapis, etc., son of Psammethēk, IM.139.

Thaiḥepimu, Head of door-openers of Serapis, etc., son of 'Ankh-ḥap and Ēsireshti, IM.4209.

Unnūfer and 'Anemḥo $\text{𓂏} \text{𓂏}$, both God's fathers and Prophets, sons of Pedenefertem, IM.78.

Unnūfer Psammethēk-ibsonb , son of Basa , IM.4006.

Unnūfer, Prophet, son of Psammethēk-sonb and Irterau. Names and titles, id. ib. No. 1152.

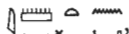
Weḥbrēc Amentefnakht , son of Psammethēk and Tanefertem, IM.4022.

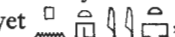

Zeamūnef'ankh , IM.5943 [N.421/411; No. 261]. Text, CHASSINAT, op. cit. xxii (1900), p. 171 [cii] (as Apis I of Dyn. XXVI).

Ze-ēsef'ankh, son of Pentahayet , IM.3099 [N.677]. Text, id. ib. xxi (1899), p. 59 [iii]; see PIERRET, *Cat.* No. 284.

Zehō, son of Hēpmen  and Khedeb-yerboni, IM.136.

Zehō, son of Uzahōr, IM.4163 [N.421/408]. Text, ČERNÝ Notebook, 117, p. 4 [upper].

Names uncertain or lost. IM.4061, originally with cartouches of Saḥurēc, now completely effaced. IM.4244, son of Ḥarbes , N.679/3094 [S.1890]; text, CHASSINAT, op. cit. xxi (1899), pp. 59–60 [v]; see PIERRET, *Cat.* No. 290.

'Aḥmosi  (good name), son of Mutardais , S.N.10 [No. 440]. Text, CHASSINAT, op. cit. xxv (1903), pp. 53–4 [clxiv].

In other museums

Late Period unless otherwise dated

Antwerp, Museum Vleeshuis.

Man kneeling before Apis-bull, No. 79.1.457. *Oudheidkundige Musea. Vleeshuis. Cat. viii, Egypte* (1959), pl. ix [11], p. 26.

Berlin Museum.

Iuf'a (same man as Louvre, IM.4076, see *supra*), son of Pashenptah, *kh*-priest, etc., and Neitikhert, fragment, temp. Darius I, No. 3423. Text, BURCHARDT in *Ä.Z.* 49 (1911), p. 72 [3]. See *Ausf. Verz.* p. 312.

Stela inscribed on both sides, of a son of Paneferrekh(?), No. 2144 (East). See id. ib. p. 312.



Bologna, Museo Civico.

Apis-bull and 4 lines of demotic, No. 1946. See KMINÉK-SZEDŁO, *Catalogo di Antichità Egizie* (1895), p. 215; CURTO, *L'Egitto antico* (1961), p. 151 [394].

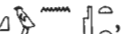
Brussels, Musées Royaux d'Art et d'Histoire.



Ḥarsiēsi, son of [Pa]juenḥor  and Kewenēsi , Dyn. XXVI, E.3468 (formerly in Prince Napoleon and Ravestein Collns.). DE MEULENAERE, *Het leven na de dood in het Oude Egypte* (Tentoonstelling van 21 juni tot 28 september 1969. Provinciaal Gallo-Romeins Museum—Tongeren), No. 71 with pl. 14; LIMME in *Chron. d'Ég.* xlvii (1972), fig. 3, pp. 103–9; id. *Stèles égyptiennes*, No. 16 with fig. See DE MEESTER DE RAVESTEIN, *Musée de Ravestein*, i (1871), p. 28 [25].



Cairo Museum.

'Ankh-ḥor  Weḥbrēc, Overseer of infantry, etc., son of Peḥen  and Tadeusiri, Dyn. XXVI–XXVII, re-used in Monastery of Apa Jeremias, JE 43204. VERCOUTTER, *Textes*, pl. xix, pp. 117–21; QUIBELL, *Saqqara (1908–10)*, pl. lxxxiii, p. 146.

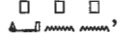

Hēpmen , son of Hēpardais  and Takhyay , Dyn. XXVI–XXVII, CG 31086. SPIEGELBERG, *Die demotischen Inschriften*, Taf. i, pp. 12–13.



Ka , Scribe of divine books, Secretary, son of Pedeneit, re-used in Monastery of Apa Jeremias, JE 40043. Text, QUIBELL, *Saqqara* (1907-8), p. 16.

Pedepenpen , son of Es-zad  and Irterau. LANZONE, *Diz.* pl. cci [2], p. 530.

Pedësi, God's father, Secretary of Ra-setau, son of Pashenptah , God's father, and Tahaib(?) , with hieroglyphic and demotic texts, CG 31157. SPIEGELBERG, op. cit. Taf. xx, pp. 63-4.

Psammethek, son of Pedeharkhebi  and Irterau , JE 15037. LANZONE, *Diz.* pl. cciii [1], pp. 531-2. Names, LIEBLEIN, *Dict.* No. 1159.

Ptahhotp, God's father, *wp-ntrwy*, etc., son of Nekau-mer(y)neteru  and Renpetnefert , probably Dyn. XXVII, JE 20014. VERCOUTTER, *Textes*, pl. xviii, pp. 113-16. Text, PIEHL in *A.Z.* xxv (1887), pp. 122-3 [xlvii] (as No. 2316). See MASPERO, *Guide*, p. 472 [4496].



Siësi , Inspector of *sem*-priests, Secretary of Ra-setau, etc., son of 'Ankhunnüfer , Secretary of the Great Place, etc. Text, PIEHL, *Inscr. hiéro.* 3 Sér. lxxxiii [S].

Unnüfer, JE 4889.

Chicago, Oriental Institute.

Mersurëc , Scribe of the Lord of the Two Lands, New Kingdom, No. 9375.

Grenoble, Musée de Peinture et de Sculpture.

Pedësi, son of Irhepiaut  and Tent , No. 14 [Inv. 1950]. KUÉNY, *L'Égypte ancienne au Musée de Grenoble*, fig. on 15th p. [3]; DEVÉRIA squeezes, 6167, ii. 151. Text, MORET in *Revue Égyptologique*, n.s. i (1919), p. 172 [x]. See TRESSON, *Catalogue descriptif des antiquités égyptiennes de la Salle Saint-Ferriol* (repr. from *Bulletin de l'Académie delphinale*, 6 Sér. iv [1933]), pp. 21-2 [3].

Hildesheim, Roemer-Pelizaeus-Museum.

Zeptahefankh and Harsiësi, sons of Thonüfer , all God's fathers, *sem*-priests, etc., No. 2372. LIMME in *Chron. d'Ég.* xlvii (1972), fig. 1, pp. 83-92. See IPPEL and ROEDER, *Die Denkmäler des Pelizaeus-Museums zu Hildesheim*, p. 90; KAYSER, *Die ägyptischen Altertümer im Roemer-Pelizaeus-Museum in Hildesheim* (1973), p. 120.

Leningrad, State Hermitage Museum.

Irefaenubaste , No. 1095. Text, STRUVE, *Etyudy po istorii severnogo Prichernomor'ya, Kavkaza i Sredney Azii*, pp. 305 [55], cf. 290 (as Ptolemaic). See GOLÉNISCHEFF, *Inventaire de la collection égyptienne* (1891), p. 167.

Meshotp , son of Ptahardais, No. 1096. Text, STRUVE, op. cit. pp. 305 [53], cf. 290 (as Ptolemaic). Names, LIEBLEIN, *Dict.* No. 2549. See GOLÉNISCHEFF, op. cit. p. 167 (as Dyn. XXVI).



London, University College Museum.

Kha . . .  . . . , Mourner of Apis, No. 14610.

Pedubaste, son of Psammethek, formerly in Amherst and Harding Smith Collns., No. 15807. Two names, LIEBLEIN, *Dict.* No. 2382. See *Sotheby Sale Cat.* (AMHERST), June 13-17, 1921, No. 238 [3]; id. November 1-2, 1922, No. 220.

Pefteu^cauneit , son of Pakap  and Ēsiardais , No. 15993.





Marseilles, Musée d'archéologie.



Peḳṣa , son of Ḥarkhebi  and Tiamūn , before bull-headed Apis, Imhōtep and Ptaḥ, Dyn. XXX, No. 246. *Le Nil et la société égyptienne* (Musée Borély, Marseille, 6 décembre–1^{er} mars 1973), No. 173 with fig.; WILDUNG, *Imhotep und Amenhotep*, pp. 40–2 [19] with Taf. v and fig.; id. *Egyptian Saints. Deification in Pharaonic Egypt*, fig. 30; CAIRO, CENTRE OF DOCUMENTATION photo. S.R., Box 173, P. 5019. Text, MASPERO in *Rec. Trav.* xiii (1890), pp. 123–4 [46]. See id. *Catalogue du Musée Égyptien de Marseille* (1889), p. 28 [46].





Vienna, Kunsthistorisches Museum.

Diptaḥiau, *wmrw*-priest, etc., Inv.5833. REINISCH, *Miramar*, Taf. xxxviii, pp. 254–5 [16].

Pedeḥarpekhrod, son of Pede . . .  and Zeubastes^cankh, Inv.5852. Id. ib. Taf. xxxvi, pp. 253–4 [14].

Zeḥo , Neb^cankh , son of Ḥarmosi , both Door-openers of Ptaḥ, and Tashentihet , Inv.6126.

Mentioning Hager(?) , son of Pemu , Inv.5853. Text, id. ib. Taf. xl [5], pp. 257–8 [32].

. . . behēsi . . . , son of Ptaḥnaḳay(?)  [] , Inv.5824. Id. ib. Taf. xxxvii, p. 254 [15].

Others, Inv.5827, 5831, 5841. Inv.5831, id. ib. Taf. xxxv, p. 253 [3].

Present location unknown

Psammethēk (good name), son or husband of Te(nt)ubaste , fragment, Late Period, at one time in Verlaque Colln. Texts, MASPERO in *Mélanges d'archéologie égyptienne et assyrienne*, ii (1875), pp. 212–13 [18].

Panūfer , MARIETTE, *Fouilles*, pl. li [top left].

Apis-bull in shrine being conveyed in bark on wheels, Ptolemaic or Roman. FARAG in *J.E.A.* 61 (1975), pl. xxiii [1], pp. 165–6. (Others, see *supra*, p. 573, where the date is to be corrected, and Mīt Rahîna, Embalming House of Apis-bulls.)

OBJECTS CONNECTED WITH THE SERAPEUM

Statues.

Base with cartouches of Ramesses II, granite. Cartouches, MARIETTE, *Mastabas*, p. 445 [lower middle].

Kha^cemwēset (son of Ramesses II). (a) Holding naos with statue of bull-headed Apis, with a princess (text lost) in relief by left leg, lower part, in court of the house of the Service des Antiquités at Saqqāra; DRIOTON in *Ann. Serv.* xli (1942), pl. i, pp. 21–7; princess, see DESROCHES-NOBLECOURT in SCHAEFFER, *Ugaritica III*, p. 202 with note 2; see GOMAA, *Chaemwese* [etc.], p. 80 [33], cf. Abb. 12 [a]; KATER-SIBBES and VERMASEREN, *Apis, I*, p. 10 [26], cf. pl. xxi (from DRIOTON). (b) Statue-base, re-used in Monastery of Apa Jeremias; text, QUIBELL, *Saqqara (1908–10)*, pp. 45–6, cf. (1907–8), p. 2; see GOMAA, op. cit. p. 81 [37]. (c) Statue-base, granite; id. ib. p. 81 [39] with Taf. iii, Abb. 14 [a].

Ra^cmeses-emperamūn , Steward and Overseer of the Treasury of his lord



Kha'emwëset (son of Ramesses II), holding naos, headless, temp. Ramesses II, in court of the house of the Service des Antiquités at Šaqqâra. DRIOTON, op. cit. pl. ii, pp. 27-35. See GOMAA, op. cit. p. 80 [34], cf. Abb. 12 [b]; KATER-SIBBES and VERMASEREN, op. cit. pp. 10-11 [27], cf. pl. xxi (from DRIOTON).

Man kneeling with naos of Ptaḥ-Sokari-Osiris, with remains of text, late Ramesside, in Vienna Mus. Inv. 5773. HALL in *Apollo*, lxxxv (1967), fig. 12, p. 95; *Meisterwerke. Führer durch das Kunsthistorische Museum*, 1 (1958 and 1968), fig. 3 [middle]; KOMORZYNSKI, *Das Erbe des alten Ägypten*, Abb. 13 [middle]; see REINISCH, *Mirammar*, pp. 241-2 [28], 257 [31], cf. Taf. xl [4] (naos); *Uebersicht* (1895), p. 34 [XIII]; (1923), p. 9 [XIII].

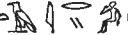

Block-stature, text effaced, granite, late New Kingdom, in Brussels, Mus. Roy. E.2147. CAPART in *Bull. Mus. Roy.* 2 Sér. iii (1910), p. 15 with fig.

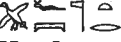
Triple block-stature of Amenḥotp, Penamün , and Tairi-sherit  (woman), granite, Ramesside, probably from here, in Louvre, N.435. VANDIER, *Manuel*, iii, pl. clii [5], p. 672.

Ptaḥaba , Guardian of the house, double block-stature with remains of text, fragmentary, Dyn. XXVI, probably from here, in Louvre, E.17449. See BOTHMER, *Eg. Sculp.* p. 36.

Stature-base of Psammethek , son of Pefḥerinüter  and 'Arptaḥ-ḥap , Late Period. Text, MARIETTE, *Mastabas*, p. 457 [H 15].

Apis-bull protecting man kneeling with offering-table, heads lost, Late Period, in Cairo Mus. CG 683. BORCHARDT, *Statuen*, iii, Bl. 125, p. 28; MASPERO, *Eg. Art*, pl. facing p. 112, cf. pp. 115 and 116 with note; id. *Essais*, fig. 37, p. 134 with note 2 (description in both confused with Cairo CG 676).



Heres'ankh , Prophetess of Philotera (daughter of Ptolemy I Soter), etc., daughter of Neferebrëc , Prophet, and Heres'ankh, headless, Ptolemaic, in Louvre, N.2456. RICHER, *Le Nu*, fig. 173; text, PIERRET, *Rec. inscr.* ii, p. 83 [top] (with sketch); BRUGSCH, *Thes.* 946; names and some titles, LIEBLEIN, *Dict.* No. 2520; see PIERRET, *Cat.* No. 33; BOREUX, *Guide*, ii, p. 491; VANDIER, *Guide* (1948), p. 80; (1952), p. 82; (1973), pp. 154-5.

Man or god, head, arms, and lower parts of legs lost, with text on back pillar, Ptolemaic, probably from here, in Stafford Colln. BOTHMER, *Eg. Sculp.* pl. 120, pp. 168-9 [129].

Head ('Boston Green Head'), with remains of text on back pillar, green schist, Ptolemaic, formerly in Prince Napoleon Colln., now in Boston Mus. 04.1749. FERRI PISANI in *Gazette des Beaux-Arts*, i (1859), fig. on p. 281 [upper] (reversed), cf. p. 275; LENORMANT in ib. xxiii (1867), fig. on p. 31 (reversed); DELBRÜCK, *Antike Porträts*, Taf. 12, p. xxviii; *Handbook* (1910), fig. on p. 34 [upper]; (1920), fig. on p. 53; (1925), fig. on p. 26; (1930 and 1935), fig. on p. 25; (1947 and 1956), fig. on p. 26; (1964), fig. on p. 201 [top]; (1976), fig. on p. 177 [bottom]; DUNHAM in *Boston Mus. Bull.* xxxv (1937), figs. on p. 71, cf. p. 70; id. *The Egyptian Department and its Excavations*, fig. 12; SMITH, *Anc. Eg.* (1942), fig. 101; (1952), fig. 100; (1960), fig. 113; id. in *Boston Mus. Bull.* xlvi (1949), fig. 6, p. 26; id. *Art . . . Anc. Eg.* pl. 185, p. 252; HALL in HAMMERTON, *Universal History of the World*, ii, fig. on p. 1020 [upper right]; PIJOÁN, *Summa Artis*, iii (1945), fig. 637; WOLF, *Kunst*, Abb. 662, p. 628; id. *Die Kultur Ägyptens*, Abb. 85; ATARASHI, *Egypt*, pl. 69; WOLDERING, *Götter und Pharaonen*, Abb. 114; BOTHMER, *Eg. Sculp.* pls. 100, 101 [272], pp. 138-40; id. in *The Brooklyn Museum Annual*, iv (1962-3), fig. 8, p. 46; TERRACE in *The Connoisseur*, clxix (1968), col. pl. 3 on p. 120, cf. p. 118; MCKEON and CARR, *Portraiture in Ancient Egypt* (Gallery Guide, Mus. of Fine Arts, Boston, Nov. 28, 1972-Jan. 7, 1973), fig. 16; BRECKENRIDGE, *Likeness. A Conceptual History of Ancient Portraiture*, fig. 88.

Divinities.

Osiris, basalt, Dyn. XXVI, in Cairo Mus. CG 38368. Text, DARESSY, *Statues*, p. 100; MARIETTE, *Mon. div.* pl. 77 [e] (as bronze); DE ROUGÉ, *Inscr. hiéro.* pl. ccc [top].

Osiris, with figures of 'Aḥmosi , Greatest of the five of Thoth, Overseer of the Treasury, etc., and wife Mutnezemt  on base, Dyn. XIX, in Cairo Mus. CG 38411. DARESSY, *Statues*, pl. xxi, pp. 108-9.

Tuēris, inscribed, black schist, Dyn. XXVI, in Cairo Mus. CG 39147. Id. ib. pl. lv, pp. 285-6; MARIETTE, *Album du Musée de Boulaq* (1872), pl. 5 [right].

Stelae (other than Apis-stelae).

Apries offering to Ptaḥ, with hieroglyphic and Carian texts, probably from here, in Cairo Mus. JE 49060. MASSON and YOYOTTE, *Objets pharaoniques à inscription carienne*, pl. i, figs. 11, 12, pp. 17-20; Carian text, SAYCE in *Transactions of the Society of Biblical Archaeology*, ix (1893), pl. i [ii, 2], pp. 125-6, 146 [ii, 2]; see MASPERO, *Guide* (1902), p. 260 [701 bis].

Blocks of Kha'emwēset (son of Ramesses II).

Remains of 8 lines of text. Text, BRUGSCH, *Thes.* 957 [lower]-958; DEVÉRIA squeezes, 6170C, 5; GOMAA, *Chaemwese* [etc.], Abb. 10, 11 (from BRUGSCH), p. 80 [31].

Upper part of Kha'emwēset, in Louvre, N.518. WENIG in *Forschungen und Berichte*, 14 (1972), Taf. 1 [1], pp. 41-2 [1]; REVILLOUT, *Le Roman de Setna* (1877), frontispiece; id. in *Rev. Arch.* n.s. xxxvii (1879), pl. xiv facing p. 335; GOMAA, op. cit. Taf. viii [a], p. 80 [32]; DEVÉRIA squeezes, 6170C, 6; head, MYŚLIWIEC, *Le Portrait royal dans le bas-relief du Nouvel Empire*, pl. cix [242]. See PIERRET, *Cat.* No. 3; BOREUX, *Guide*, ii, p. 481.

Two registers, I (incomplete), Kha'emwēset kneeling offering to Ptaḥ, II, [Kha'emwēset] with Opening-the-Mouth instruments before Apis-bull in shrine on sledge (II now in Louvre, E.25497). GOMAA, op. cit. pp. 81-2 [40] with Taf. v [b]; WENIG, op. cit. Taf. 2 [1, 2], pp. 42-3 [3]; II, VANDIER in *La Revue du Louvre*, xv (1965), fig. 8, p. 42; *Vingt ans*, p. 20 [Cat. 77] with plate.

Six fragments of jambs, with personifications led by Kha'emwēset, in Vienna Mus. Inv. 5081-3, 5095-7. KOMORZYNSKI in *Archiv für Orientforschung*, xix (1959-60), pp. 67-73 with Abb. 1-4; see GOMAA, *Chaemwese* [etc.], p. 81 [35] with Abb. 13 (Inv. 5095-7). Inv. 5081-2, 200 *Meisterwerke. Führer durch die Kunsthistorischen Sammlungen in Wien*, 13 (1931), fig. 15; *Meisterwerke. Führer durch das Kunsthistorische Museum*, 1 (1958 and 1968), fig. 5; DEMEL, *Ägyptische Kunst*, Abb. 26; LEBOVITCH in *J.N.E.S.* xii (1953), fig. 18, p. 107 (as Ptolemaic); see *Uebersicht* (1895), p. 38 [143]; (1923), p. 13 [143]. Inv. 5083, see Vienna. 5000 *Jahre*, p. 79 [118].

Various

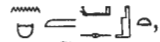
Offering-table of Pedusiri, son of Haremḥab  and Neḥemesēsi , dedicated to Apis, Late Period, in Louvre, D 79. ARCHIVES phot. E.684; text, GOODWIN MSS. 31279, 29 [top]; names, LIEBLEIN, *Dict.* No. 1202.

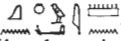
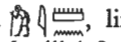
Hawk-coffin dedicated by Kēnamūn , Craftsman of Pharbaethos, son of Weramūn , limestone, late New Kingdom, in Louvre, A.F.448. Text, WIEDEMANN in *P.S.B.A.* xiii (1891), p. 273 [3]. See VANDIER, *Guide* (1973), p. 123.

Apis canopic-jars. (a) Ramesses II, alabaster, in Louvre, N.5438; see PIERRET, *Cat.* No.

367. (b)–(d) Three (two inscribed), Dyn. XXVI, brought from Egypt by Borély in 18th century, in Marseilles, Mus. d'archéologie, 300–2; texts, WILBOUR MSS. iii.D.11 [near top]; see MASPERO, *Catalogue du Musée Égyptien de Marseille*, pp. 65–6 [100–2]. (e)–(i) Five, Late Period, three of them at one time in the possession of Le Maire, two in the possession of Sicard; LUCAS, *Voyage . . . dans la Turquie, l'Asie, Sourie, Palestine, Haute & Basse Egypte*, &c., ii (1724), pl. facing p. 100.

Vase-fragment of Ramesses IX, faience, in Louvre, N.2255. See PIERRET, *Cat.* No. 380 (as Ramesses VIII).

Cylindrical vase of Necho II, alabaster, in Louvre, N.462. See BOREUX, *Guide*, ii, p. 572; PIERRET, *Cat.* No. 383.

Jar with cartouche of Apries, dedicated to Apis, alabaster, in Cairo Mus. CG 18489. VON BISSING, *Steingefässe (Cat. Caire)*, Taf. v, pp. 96–7 with text (as from Abûşîr).



Flat-bottomed jar dedicated to Apis by Unnûfer, son of Psammethék, faience, Dyn. XXVI, in Cairo Mus. CG 18037. Id. *Fayencegefässe (Cat. Caire)*, pp. 107–8 with fig. and text (as from Abûşîr).

Bronze aegis with cartouches of Amasis, in Cairo Mus. Temp. No. 30.5.26.1. MARIETTE, *Album du Musée de Boulaq* (1872), pl. 37 [558]; DE ROUGÉ, *Album photo.* pl. 133.

Intrusive or re-used reliefs.

From New Kingdom tombs.

King Menkauhor, with texts of Amenemōnet, Head of craftsmen of the Lord of the Two Lands (tomb, p. 552), end of Dyn. XVIII, in Louvre, B 48 [IM.2614; N.151; E.3028]. BERLANDINI-GRENIER in *B.I.F.A.O.* 76 (1976), pls. liii–lv, pp. 303–15; BERLANDINI in *Bull. Soc. fr. d'Ég.* No. 83 (Oct. 1978), fig. 1, p. 25; DE ROUGÉ, *Recherches sur les monuments* [etc.] (1866), pl. vi, p. 99 (repr. in *Bibl. Ég.* xxvi, pl. vi, p. 95); id. *Album photo.* pl. 102; MEYER, *Geschichte des alten Aegyptens*, ii, fig. on p. 45; MASPERO, *Hist. anc.* i, fig. on p. 415; id. *Égypte*, fig. 97; BOREUX, *Guide*, ii, pl. lxiii [left], pp. 451–2; PETRIE, *History*, i, fig. 59; GALVANO, *L'Arte egiziana antica*, fig. 10; RICHER, *Le Nu*, fig. 77; MICHALOWSKI, *Art*, fig. 234; DEVÉRIA squeezes, 6166, i. 3; WILKINSON MSS. xxiv. 12 [lower left]; ARCHIVES phot. E.1020. Head, L. D. iii. 291 [19]. See DE ROUGÉ, *Notice des monuments* (1883), p. 66; VANDIER, *Guide* (1948), pp. 23–4; (1952), p. 24.

Two remaining registers, I, Thuthu , Scribe, Physician, and probably wife Nemaui (?)  before Duamut and Nephthys, II, Thuthu and sister Naia  before Kēbhsenuf and King Menkauhor, end of Dyn. XVIII, in Louvre, B 50 [N.152]. JONCKHEERE, *Les Médecins de l'Égypte pharaonique*, fig. 24, p. 72; Kēbhsenuf and Menkauhor, BERLANDINI in *Bull. Soc. fr. d'Ég.* No. 83 (Oct. 1978), fig. 2, p. 25; DEVÉRIA squeezes, 6166, ii. 161. Names and titles, PIERRET, *Rec. inscr.* ii, p. 28; LIEBLEIN, *Dict.* No. 432, *Suppl.* p. 953. See DE ROUGÉ, *Notice des monuments* (1883), pp. 67–8; BERLANDINI-GRENIER in *B.I.F.A.O.* 76 (1976), pp. 315–16.

C. NORTHERN GROUP

Map LXIX

EMERY and SMITH (H. S.), *The Sacred Animal Necropolis at North Saqqâra. The Main Temple Complex and the Northern Dependencies*, in preparation; MARTIN, *The Sacred Animal Necropolis at North Saqqâra. The Southern Dependencies of the Main Temple Complex*, in

press (1979). Plans, EMERY in *J.E.A.* 52 (1966), fig. 1 on p. 4; 53 (1967), fig. 1 on p. 142; 55 (1969), fig. 1 on p. 32; 56 (1970), pl. xviii after p. 10; 57 (1971), pl. xiv facing p. 12; SMITH (H. S.), *A Visit to Ancient Egypt*, fig. 2; MARTIN in *J.E.A.* 60 (1974), figs. 1, 2, 5, 10, 11, cf. 3 (sections) facing pp. 15, 16, 26, 27 and on pp. 17, 20; id. *Hetepka*, pl. 2. Ibis Galleries, POCOCKE, *A Description of the East* (1743), i, p. 54, with plan on pl. xxi [B]; L. D. *Text*, i, pp. 141-2 [LS 4] with plan.

TEMPLE. Nektanebos II.

EMERY in *J.E.A.* 53 (1967), pp. 142-3 (= id. in *Antiquity*, xlii (1968), pp. 99-100), with plan and section, pls. xix, xx, cf. fig. 2; 55 (1969), pp. 31-5, with plan and views, pls. x, xi; 56 (1970), pp. 5-7, with plans, pls. ii, iii; 57 (1971), p. 4, with plan, pl. i; SMITH (H. S.) in ib. 62 (1976), pp. 14-17, with plan, fig. 1; id. *A Visit to Ancient Egypt*, pp. 29-37, with plans, figs. 5, 6, 8.

Blocks with remains of scenes with the King, texts, and royal titles, etc., MARTIN, *Hetepka*, Nos. 340-411B. Upper part of the King before bull-headed Apis, and before [Mother-of-Apis] (= No. 363 of MARTIN), EMERY in *J.E.A.* 55 (1969), pl. ix [2]; SMITH (H. S.), *A Visit to Ancient Egypt*, pl. i [B], p. 34. Cornice-blocks with cartouches (= Nos. 352-3 of MARTIN), EMERY in *J.E.A.* 55 (1969), pl. ix [3, 4], p. 34.

Finds from Temple Terrace and neighbourhood of Animal Galleries

Texts, MARTIN, *Hetepka* (numbers in square brackets are those of the publication).

Statues and statuettes.



Lower part of seated statue, granite, Dyn. III, in Brit. Mus. 67154. [9]; see EMERY in *J.E.A.* 53 (1967), p. 143; *Brit. Mus. Quarterly*, xxxiv (1969-70), p. 186.

Fragment of statue-base of Khuit[rē]  (woman), Dyn. V-VI, in Edinburgh, Roy. Scot. Mus. 1969.81. [86].



Statuette-fragment(?), Ptahshepses, Dyn. V-VI. [105].

Front part of prostrate King, probably Ramesses II, schist, in Edinburgh, Roy. Scot. Mus. 1971.130. *On View (A Guide to Museum and Gallery Acquisitions in Great Britain)*, 6 (1971-2), 12th pl. [middle left] after p. 10, cf. p. 27. See ALDRED in *Triennial Report 1971-3*, p. 27.

Miniature block-statuette of Paser, Vizier (Theb. tb.106), temp. Sethos I to Ramesses II, faience, in Hildesheim Mus. 4886. [140]; *Meisterwerke altägyptischer Keramik*. Höhr-Grenzhausen, 16. Sept. bis 30. Nov. 1978, No. 293 with fig.

Double-statuette, Ma[hu](?)  . . . of the fields of Amūn, and wife Tia , both seated, schist, Dyn. XIX, in Cairo Mus. JE 91915. [144].





Kanüfer , God's father and Prophet of the Ram 'Lord of Per-ka', squatting with figure of Ptah, wood, New Kingdom, in Cairo Mus. JE 91118. [203]; EMERY in *J.E.A.* 53 (1967), pls. xxiv [2], xxi [4, middle], p. 143; id. in *Antiquity*, xlii (1968), pls. xiv [d], xv [b, middle], p. 99; *I.L.N.* March 25, 1967, fig. 6 on p. 30; BACON in ib. July 29, 1967, on fig. 4 on p. 25; Aug. 5, 1967, fig. 2 on p. 25.

Lower part of statue of Sety , Custodian of the Treasury, son of Ptah-kha' , kneeling with figure of Ptah, schist, New Kingdom, in Brit. Mus. 67156. [201].



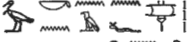



Torso and legs of statue of Sesonchis V, glass frit, in Cambridge, Fitzwilliam Mus. E.6. 1969. [155]; see EMERY in *J.E.A.* 53 (1967), p. 143 [near bottom] (as Tuthmosis II).

A kneeling King, unfinished, wood, 3rd Int. Period, in Brit. Mus. 67143. See *Brit. Mus. Quarterly*, xxxiv (1969-70), p. 186.



Man holding figure of Ptaḥ, wood, 3rd Int. Period, in Brit. Mus. 67138. EMERY in *J.E.A.* 53 (1967), pls. xxiii [3], xxi [4, left], p. 143; id. in *Antiquity*, xlii (1968), pls. xiv [b], xv [b, left], p. 99; BACON in *I.L.N.* July 29, 1967, figs. 6 on p. 24, on 4 on p. 25; *Exhibition of Recent Discoveries in Egypt and the Sudan by the Egypt Exploration Society*. Brit. Mus. 16th Oct.-30th Nov. 1968, frontispiece; SMITH (H. S.), *A Visit to Ancient Egypt*, pl. vi [A]; *On View (A Guide to Museum and Gallery Acquisitions in Great Britain)*, 4 (1969-70), 9th pl. after p. 32 [right bottom], cf. p. 50. See *Brit. Mus. Quarterly*, xxxiv (1969-70), p. 186.



Bekennanefu  | Psammethek-menkhib  , Royal scribe, etc., son of 'Ankh-sineb'ankh  , kneeling with naos of Ptaḥ, re-dedicated in demotic by Ḥarpaësi, son of Ḥaremḥab, schist, late Dyn. XXVI or Dyn. XXVII, in Toronto Mus. 969. 137.1. [199]; EMERY in *J.E.A.* 53 (1967), pls. xxiii [1, 2], cf. xxi [1], p. 143; id. in *Antiquity*, xlii (1968), pl. xiv [a], p. 99; *I.L.N.* March 25, 1967, fig. 3 on p. 30; BACON in *ib.* Aug. 5, 1967, figs. 4-6 on p. 26; NEEDLER in *Rotunda. The Bulletin of the Royal Ontario Museum*, 2 [4] (1969), fig. on p. 31; *Gazette des Beaux-Arts*, lxxvii (1971), Supp. Feb. 1971, fig. 203; SMITH (H. S.), *A Visit to Ancient Egypt*, pl. vi [D].

Man with figure of Ptaḥ, wood, Dyn. XXVI, in Cairo Mus. JE 91115. EMERY in *J.E.A.* 53 (1967), pl. xxiii [5]; id. in *Antiquity*, xlii (1968), pl. xiv [c], p. 99; BACON in *I.L.N.* July 29, 1967, fig. 2 on p. 23; SMITH (H. S.), *op. cit.* pl. vi [B]; id. in *Bull. Soc. fr. d'Ég.* Nos. 70-1 (June-Oct. 1974), fig. on p. 19.

Pentashendyt  , son of 'Ankhpefḥeri  , Prophet of Amūn, and Theshkenspert  , kneeling with figure of Osiris, schist, Dyn. XXVI-XXVII, in Cairo Mus. JE 91113. [202]; EMERY in *J.E.A.* 53 (1967), pl. xxiv [1], p. 143; BACON in *I.L.N.* Aug. 5, 1967, fig. 11 on p. 27 (as diorite).











[Pede]jatun(?), Regulator of the Temple of Ptaḥ, with figure of Ptaḥ, wood, Late Period, in Cambridge, Fitzwilliam Mus. E.8.1969. [204]; EMERY in *J.E.A.* 53 (1967), pl. xxi [4, right]; id. in *Antiquity*, xlii (1968), pl. xv [b, right], p. 99; *On View (A Guide to Museum and Gallery Acquisitions in Great Britain)*, 4 (1969-70), 7th pl. after p. 16 [top left], cf. p. 21.

Bekenkons  , *sem*-priest, etc., kneeling with figure of Osiris(?), lower part, damaged, schist, Late Period, in Brit. Mus. 67155. [205].

Bekenptah  , *warb*-priest of Ptaḥ, Scribe of the army in Memphis, etc., seated clad in long robe, headless, probably granite, Late Period. [200].

Double-statuette, man and wife, wood, Late Period, in Cambridge, Fitzwilliam Mus. E.12.1969. BACON in *I.L.N.* July 29, 1967, fig. 11 on p. 24; *On View (A Guide to Museum and Gallery Acquisitions in Great Britain)*, 4 (1969-70), 7th pl. after p. 16 [top middle], cf. p. 21.

Divinities. Late Period.

Osiris. (a) Seated, dedicated by Deubasteiau  , son of Pefteu'aubaste  , schist, in Cairo Mus. JE 91116; [207]; EMERY in *J.E.A.* 53 (1967), pl. xxiv [3], p. 143. (b) Seated, dedicated by Mosi, son of Zeamūnef'ankh(?)  , diorite with traces of gilt, in Toronto Mus. 972.51.16; [206]. (c) Dedicated by Pedēsi, son of 'Ankh-khons  , basalt, originally gilded, in Bolton Mus. A-76. 1969; [208]; see *On View (A Guide to Museum and Gallery Acquisitions in Great Britain)*, 5 (1970-1), p. 13. (d) Perhaps Osiris, fragment, dedicated by a son of Tademehyt   (mother), granite, in Edinburgh, Roy. Scot. Mus. 1969.80; [210]. (e) Dedicated by a *warb*-priest of Ptaḥ, Sistrum-player of Ḥaṭḥor Mistress of the Sycamore, wood, in Cairo Mus. JE 91114; [209].

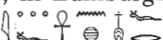
Ptah. (a) Throne and legs, dedicated by Shedsunefertem , Greatest of the Directors of craftsmen, etc., faience, temp. Sesonchis I, in Edinburgh, Roy. Scot. Mus. 1971.165; [214]. (b) Base, dedicated by Iuf'ankh-nüfer , wood, in Birmingham, City Mus. 460.69; [213].

A goddess, bust, schist; EMERY in *J.E.A.* 53 (1967), pl. xxvi [3] facing p. 145; BACON in *I.L.N.* July 29, 1967, fig. 14 on p. 25.

Animals and sphinxes.

Uraeus-serpent and Sokari as hawk on sledge, statue-group with cartouche of Ramesses II, incomplete, glass, in Cairo Mus. JE 91117. [123]; EMERY in *J.E.A.* 53 (1967), pl. xxv [5], p. 143; id. in *Antiquity*, xlii (1968), pl. xv [a], p. 100; BACON in *I.L.N.* Aug. 5, 1967, fig. 7 on p. 26.

Baboon, faience, Late Period, in Cairo Mus. JE 91112. SMITH (H. S.), *A Visit to Ancient Egypt*, pl. vii [D]; EMERY in *J.E.A.* 55 (1969), pl. vi [4].

Head of lioness, wood, Late Period. Id. ib. 53 (1967), pl. xxvi [5], p. 143; SMITH (H. S.), op. cit. pl. vi [C].

Jackal, three statues, Late Period. (a) In London, Univ. Coll. 30565; EMERY in *J.E.A.* 53 (1967), pl. xxii [6], p. 143. (b) In New York, M.M.A. 69. 105; id. ib. pls. xxi [2], xxii [5], p. 143; BACON in *I.L.N.* July 29, 1967, fig. 8 on p. 24; LILYQUIST in *The Metropolitan Museum of Art. Notable Acquisitions 1965-1975*, fig. on p. 73 [middle]; *Report on Projects funded by the Adelaide Milton de Groot Fund* (New York, M.M.A., 1977), fig. on p. 9 [top]; see FISCHER in *M.M.A. Bull.* n.s. xxviii (Oct. 1969), p. 70.

Sphinx, Ptolemaic, in Birmingham, City Mus. 65.71.

False-doors and stelae.

Ḳednas , Supervisor of the Treasury, upper part, Dyn. V-VI. [26].



Senezem . . . , Overseer of scribes of the Two Granaries, etc., fragment, Dyn. V-VI. [33].



Zadptah , Craftsman, upper part, Dyn. III or late Old Kingdom. [13].



Stela-fragment with Nefer(t), Songstress of Bubastis, in lower register, Dyn. XIX. [130].



Mutnefert (woman), Dyn. XIX. [137].

Stela-fragment mentioning King Teti, Ramesside. [151].

Pente[nt]-khebi , Chiseller (by), son of Pedesopdu , probably Dyn. XXII. [168].

Ḳeribni , son of Unnüfer, before cow Setyerboni  on sledge, probably Dyn. XXVII. [165]; SMITH (H. S.), *A Visit to Ancient Egypt*, pl. ii [D]. •

Ptahardais , son of Thaiḥepimu , Late Period. [164].

Takhet , daughter of Takernefer(t)  (mother), Late Period. [163].

Upper part of donation-stela(?), with Apries offering field to Bubastis and Neḥi. [159].

Lintels, blocks, etc.

Two blocks of Inti , Judge and Keeper of Nekhen, late Old Kingdom. [100-1].

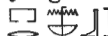
Drum-fragment of Perneb , Royal acquaintance, Dyn. V-VI. [31].

Offerings, and [wife Ḳemtrêc , Royal acquaintance], Dyn. V-VI. [44].

Block of Shesethef , Inspector of oils of King's adorners, Dyn. V-VI. [99].

Ducks in pool, Dyn. V–VI, in Cairo Mus. JE 91104. [53]; *The Egyptian Museum, Cairo in ten years 1965–1975*, pl. i, p. 42.

Lintel-fragment of a Director of bowmen, Assistant royal scribe, etc., Dyn. V. [98].

Blocks with names of Ramesses II. [121–2].











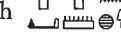

Relief-fragments from shrine of ‘Anta, probably temp. Ramesses II. [147].

Blocks mentioning brother Paraemḥab , Overseer of the cabinet, Dyn. XIX. [131–2].

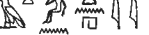
Column-base of Raḥmosi, Chief steward of Khons, etc., alabaster, Ramesside. [143].

Block with remains of text of Ptolemy II Philadelphus. [338].

Offering-tables and basins. Some fragmentary. Late Period unless otherwise stated.

‘Ankhepkhrod, in Cairo Mus. JE 91518, [268]. Ḥarardais , son of Pedēsi, [267]. Ḥarnakht and Ḥarsiēsi, sons of Esby , [270]. Ḥarsiēsi, son of Imḥōtep, in Brit. Mus. 67243, [266]. Half-brothers Ḥarwoz , son of Weḥberēc-ḥarenpe , and Pedepamenkh , son of Esbi , both sons of Tashentnehy , (mother), in Cairo Mus. JE 91143, [263]. Mesthu , Royal acquaintance, late Old Kingdom, [79]. Pedehor, [272]. Pedeneit, son of ‘Ankhepkhrod, [269]. Pedēsi, [235]. Pefḥerinüter  and Eṣhor , mentioning cow Setyerboni , probably Dyn. XXVII, in Cairo Mus. JE 91519, [260]. W[ash]ptaḥ , Dyn. V–VI, [113]. Zehō , son of Pawenhētef, [265]. A Prophet of Khufu, etc., Dyn. V–VI, in Cairo Mus. JE 91916, [80].

Other objects.

Vase of Nezem-seshet , Scribe of divine books, alabaster, Dyn. I–III. [3].

Furniture-fragment of Ramesses XI, wood, in London, Univ. Coll. 30629. [154]; see EMERY in *J.E.A.* 53 (1967), p. 143 (as Ramesses IX).

Standing sphinx, presumably part of furniture, wood, Late Period, in Cairo Mus. JE 91111. Id. ib. pl. xxiii [4], p. 143; *I.L.N.* March 25, 1967, fig. 4 on p. 30.

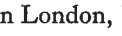
Wooden shrines or similar. (a) Fragment with Horus-name of Sethos II or Ramesses VI, in Brit. Mus. 68173; [125]. (b) Fragment of Amasis, with glass inlay and gold leaf, in Toronto Mus. 969.137.2; [160]; NEEDLER in *Rotunda. The Bulletin of the Royal Ontario Museum*, 2 [4] (1969), fig. on p. 30 [lower]; see EMERY in *J.E.A.* 53 (1967), p. 143. (c) Door fragment of Amasis, in Brit. Mus. 68169; [161]. (d) Door, man offering vase, with demotic text in ink on back, gilded, Late or Ptolemaic Periods, in Cambridge, Fitzwilliam Mus. E.5. 1969; [286]; *On View (A Guide to Museum and Gallery Acquisitions in Great Britain)*, 4 (1969–70), 7th pl. after p. 16 [top right], cf. p. 21. (e) Panel, a King offering to Isis and Harpocrates, inscribed, inlaid with glass, Late or Ptolemaic Periods, in Cairo Mus. JE 91103; [337]; EMERY in *J.E.A.* 53 (1967), pl. xxv [3]. (f) Panel, man and two gods in relief, Late Period, in Birmingham, City Mus. 442.69; id. ib. pl. xxii [3]. (g) Panels, with dedications in ink to Isis by Pedeneshmet, son of Pedepaneshmet , Late Period, in London, Univ. Coll. 8576–7; [288, 287]. (h) Panel, head of a king, probably Dyn. XXVI; SMITH (H. S.) and JEFFREYS (D. G.) in ib. 63 (1977), pl. iv [3], p. 25.

White Crown flanked by arms, wood, probably Late Period, in Cairo Mus. JE 91110. EMERY in ib. 53 (1967), pl. xxvi [1, 2], p. 143; BACON in *I.L.N.* Aug. 5, 1967, fig. 8 on p. 26.

Fragment of sarcophagus-lid of Ḥuy , First prophet of Sekhmet, etc., New Kingdom, re-used. [238].

Wooden plank from coffin with remains of texts and scenes, Late Period, re-used. MARTIN in *J.E.A.* 60 (1974), fig. 6, p. 21.

Dummy mummy of Apis-bull, skull attached to wooden body, Late Period, in Cairo Mus. JE 91318. EMERY in *ib.* 55 (1969), pl. viii [1-4], p. 33; *id.* in *Antiquity*, xliii (1969), pl. xiv [a, b], p. 108; SMITH (H. S.), *A Visit to Ancient Egypt*, pl. ii [E] and front cover; *The Egyptian Museum, Cairo in ten years 1965-1975*, pl. xii, p. 40 [54]; *A Brief Description of the Principal Monuments (Cairo Museum, 1976)*, No. 6368 with fig.; KATER-SIBBES and VERMASEREN, *Apis, I*, p. 24 [86] with pls. lviii, lix.

Probably from here.



Shrine of Nektanebos II, parts of back and sides, wood with glass inlay, formerly in Abbott and N.Y. Hist. Soc. Collns., now in Brooklyn Mus. 37.258-60E. RIEFSTAHL, *Ancient Egyptian Glass and Glazes in the Brooklyn Museum* (1968), figs. 69-71, p. 109. Nos. 37.258E and 37.260E, *id.* *Glass and Glazes from Ancient Egypt*, figs. 16a, b. See *N.Y.H.S. Cat.* p. 48 [759-61].

SOUTH IBIS GALLERIES.

EMERY in *J.E.A.* 51 (1965), pp. 4, 6-7; 52 (1966), pp. 3-6. Plan, *id.* *ib.* 51 (1965), fig. 2 on p. 7, cf. fig. 1 on p. 5 (section); 52 (1966), fig. 2 on p. 6; *id.* in *I.L.N.* March 6, 1965, fig. 4 on p. 21; SMITH (H. S.), *A Visit to Ancient Egypt*, figs. 4, cf. 3, pp. 22-9. View of forecourt, LECLANT in *Orientalia*, n.s. 42 (1973), pl. viii [9], pp. 400-1; of entrance, EMERY in *J.E.A.* 52 (1966), pl. i [3], p. 5; of galleries, some showing pots with mummies, 51 (1965), pl. iv [1, 2] facing p. 6; 52 (1966), pls. ii, iii [1, 2], p. 5; *id.* in *I.L.N.* March 6, 1965, figs. 2 on p. 21, 7 on p. 23; LAUER, *Saqqara*, pl. 166. View of rock-cut statues, Old Kingdom, restored in Late Period, EMERY in *I.L.N.* March 6, 1965, fig. 9 on pp. 22-3; *id.* in *J.E.A.* 51 (1965), pl. ii [2], p. 6; 52 (1966), pl. i [4], p. 5. Decorated wrappings of mummies, *id.* *ib.* 51 (1965), pl. v, p. 4; 52 (1966), fig. 4, pp. 6, 8; *id.* in *I.L.N.* March 6, 1965, fig. 10 on p. 23; one, with Nefertem, in Brit. Mus. 67149, MACQUITTY, *Island of Isis*, figs. on p. 52, cf. on p. 53; LAUER, *Saqqara*, pl. 168.

Probably from here.

Ibis mummy, in Vienna Mus. Inv.8639. Text, BRUGSCH, *Thes.* 970 [left], cf. 969-70.

Sarcophagus of Thaenmu , Scribe of all accounts of the Treasury, son of Tadeim-ḥōtep  (mother), Dyn. XXVI. Texts, DEVÉRIA squeezes, 5372A.

Head of block-stature, Late Period, in Cairo Mus. CG 871. See BORCHARDT, *Statuen*, iii, p. 131.

HAWK GALLERIES.

EMERY in *J.E.A.* 57 (1971), pp. 4-8, with plan, pl. iii, and views, pls. iv, v [2]; SMITH (H. S.), *A Visit to Ancient Egypt*, pp. 45-9, with plan, fig. 10. Decorated wrappings of mummies, EMERY, *op. cit.* pl. vi [1], p. 5. Texts of objects, MARTIN, *Ḥetepka* (numbers in square brackets are those of the publication).

Base for statuette of Ptaḥ, with Souls of Nekhen and Pe and name of Neterikhet (Zoser), bronze. EMERY, *op. cit.* pl. ix [1].

Statuette of Mut, dedicated by Pedubaste, son of Paḥor , schist, Late Period, in Cairo Mus. JE 91459. [227].

Canopic-jar of Psammetikhos I, re-used, in Cairo Mus. JE 91520. [157]; EMERY, *op. cit.* pl. vi [2], p. 5.

Hand censer with figure of a kneeling king, inscribed, bronze, Late Period, from deposit of temple equipment. EMERY, *op. cit.* pl. x [4], p. 6.

Sistrum-handle of Nektanebos II, fragment, faience. [300].

Inscribed wooden hawk-coffin, Ptolemaic. [289].

Fragment of text, gold leaf on plaster, from hawk-mummy wrapping, Late or Ptolemaic Periods. [304].

BABOON GALLERIES.

EMERY in *J.E.A.* 56 (1970), pp. 7-9, with plan, fig. 1 on p. 9, and views, pls. xi [1, 2], xii, xiii; SMITH (H. S.), *A Visit to Ancient Egypt*, pp. 41-4, with plan, fig. 9, and views, pls. i [C], iii [A]. View, LAUER, *Saqqara*, pl. 167; of chapel and entrance, SMITH (H. S.) in *Bull. Soc. fr. d'Ég.* Nos. 70-1 (June-Oct. 1974), figs. on pp. 13, 14. Plan, EMERY in *J.E.A.* 57 (1971), pl. ii, p. 4. Texts of objects, MARTIN, *Hetepka* (numbers in square brackets are those of the publication).

Statues.

Fragment with speech of Ptaḥ to Amenophis III, over life-size, faience, in Cairo Mus. JE 91304. [118].



Isis suckling Horus, inscribed, Late Period(?), in Cairo Mus. JE 91301. [211]; EMERY in *J.E.A.* 56 (1970), pl. xiv [1], p. 8; head of Horus, 55 (1969), pl. vii [5, 6].

Two baboons, Ptolemaic, one in Cairo Mus., other in New York, M.M.A. 1971.51. *Id. ib.* 56 (1970), pl. xiv [2, 3], p. 8. Cairo Mus., SMITH (H. S.), *A Visit to Ancient Egypt*, pl. iii [B]. M.M.A. 1971.51, LILYQUIST in *The Metropolitan Museum of Art. Notable Acquisitions 1965-1975*, fig. on p. 73 [bottom]; *Report on Projects funded by the Adelaide Milton de Groot Fund* (New York, M.M.A., 1977), front cover; see *Metropolitan Museum Journal*, 7 (1973), p. 155.

Baboon, Ptolemaic, in Toronto Mus. 972.51.1. MILLET in *Royal Ontario Museum Toronto. 22nd Annual Report, July 1971-June 1972*, fig. on p. 18, cf. p. 17.

Two sphinxes, Ptolemaic. One, in Cairo Mus. JE 91303, EMERY in *J.E.A.* 56 (1970), pl. xiv [lower right] (called 4); other, headless, in Cambridge, Fitzwilliam Mus. E.11.1971, *Annual Report* (1971), pl. ii [upper] (restored), p. 9.



False-doors and stelae.



Lower part of false-door, Isbu , Overseer of oils in the Two Houses, etc., and wife Henutemakhet , Prophetess of Neith, etc., on right jamb, and Ptaḥshepses and wife Khenut  on left jamb, Dyn. VI. [27]. Lintel-fragment of Isbu, [28].

Esharemwia , Elder of the hall of Ptaḥ foremost of the Two Lands in Thenent, son of Pedusiri, with Psammetikhos II before Ptaḥ and Isis. [158].



Irterau ; two registers, I, adoring seated Osiris, with Western goddess behind, II, kneeling adoring Apis-bull, Late Period. [167].

Meresh , with hieroglyphic and Carian texts, Dyns. XXVI-XXVII. EMERY in *J.E.A.* 56 (1970), pl. xv [5], p. 8; MASSON and others, *Carian Inscriptions from North Saqqâra and Buhen*, pp. 20-1 [1], 58-60 [1] with pls. i [1], ii [1], xxxi [1].

Iresh , son of Nerseker , with hieroglyphic and Carian texts, Late Period, in Cairo Mus. JE 91387. *Id. ib.* pp. 25-6 [7], 86-7 [7] with pls. vi, xxxv [1].

Pasinu , son of 'Ankh-ḥarmenḥap , with Apis-bull, Late Period. [166]; EMERY in *J.E.A.* 56 (1970), pl. xiv [lower left] (called 4).

Blocks.

Remains of three registers, I, butchers, II, sons Iynerfertenptah  and Thesenptah , both Inspectors of oils of King's adorners, and daughter Theset , Prophetess of Ḥathor, III, three offering-bringers, late Old Kingdom. [22].

Remains of personification and text mentioning Ramesses II. [124].

Offering-text of Pedubaste, Late Period. [292].

Various.

Offering-table of Amentefnakht , son of Irḥeka  and Tabes , Late Period. [261].

THE ISEUM. Burial-place of Isis Mother-of-Apis  cows. Temp. Amasis to Ptolemy XV Caesar.

EMERY in *J.E.A.* 57 (1971), pp. 10-12, with plan, pl. xiii, and views, pls. xi, xii; SMITH (H. S.) in *ib.* 62 (1976), p. 17, with view, pl. vi [3]; *id.* *A Visit to Ancient Egypt*, pp. 37-41, with plan, fig. 7, and views, pl. ii [A, B]. Dates on hieratic and demotic stelae and graffiti, see *id.* in *Rev. d'Ég.* 24 (1972), pp. 176-87.

Wooden panel with painted procession of foreigners with bull and cow, Dyn. XXVII. EMERY, *op. cit.* fig. 3, pp. 10-11; MARTIN, *Hetepka*, No. 284.

Offering-table of Uzahor  and 'Ankhpekhrod, Late Period, in Oxford, Ashmolean Mus. 1971.135. *Id.* *ib.* No. 259.

IV. Miscellaneous

Statues.

Head in White Crown, probably Teti, in Louvre, A.F.2573. VANDIER, *Manuel*, iii, pl. vii [4], p. 574. See *id.* *Guide* (1973), p. 74.

Lower part of *heb-sed* statuette of Pepy II, alabaster, in Brooklyn Mus. 16.80. Text, JAMES, *Corpus*, i, pl. xxvi [70], p. 29. See WIEDEMANN, *Ägyptische Geschichte* (1884), p. 215 with note 5; WILBOUR MSS. 2 C, 45; COONEY in *Rev. d'Ég.* 27 (1975), pp. 84 [bottom]-85 [top].

Small blue glass head, perhaps Amenophis III, in Cairo Mus. JE 4404. *Id.* *Glass Sculpture in Ancient Egypt* in *Journal of Glass Studies*, ii (1960), fig. 15, p. 24.

Divinities.

Horus, inscribed, green paste, Dyn. XXI, formerly in Allemant Colln., now in Antwerp, Mus. Vleeshuis, 79.1.234. CISELET in *Chron. d'Ég.* x (1935), pp. 320-1 with fig. See ALLEMANT, *Collection d'antiquités égyptiennes* [1878], No. 413; *A Catalogue . . . Collection of Egyptian Antiquities . . . Allemant*, Foster Sale Cat., London, May 9-10, 1878, No. 364; *Antwerp. Cat. de la Collection d'antiquités égyptiennes* (1881), pp. 36-7 [234]; *Oudheidkundige Musea. Vleeshuis, Cat. viii, Egypte*, p. 47 [230].

Isis suckling Horus, inscribed, alabaster, protected by vulture, bronze, Dyn. XXV-XXVI, formerly in N.Y. Hist. Soc. Colln., now in Brooklyn Mus. 37.400E. ROEDER, *Ägyptische Bronzefiguren*, Taf. 90 [c, d], p. 497 [669, c]; *Art of Ancient Egypt* (Emily Lowe Gallery,

Hofstra University, Hempstead, New York, Feb. 22–April 6, 1971), No. 10 with fig. (without vulture). See *N.Y.H.S. Cat.* p. 19 [291].

Osiris, dedicated by a son of Bintenduanüter (Theban tb.407), quartzite or basalt, Dyn. XXVI, in Louvre, N. 3952. Upper part, DE MEULENAERE and BOTHMER in *Kémi*, xix (1969), pl. iii, pp. 11 with note 2, and 14 with note 7. Text on back pillar, MARIETTE, *Mastabas*, p. 448 [H 4]; id. *Mon. div.* pl. 77 [c].

Ptaḥ, dedicated by Meniuser , son of Nakht, basalt, Dyn. XIX, found in trench with animal bones, in Cairo Mus. CG 38432. DARESSY, *Statues*, pl. xxv, p. 117.

Ptaḥ, unfinished, with preliminary sketch, perhaps New Kingdom, in Cairo Mus. JE 45322. DE RACHEWILTZ, *L'Arte*, Tav. 12 [left], p. 16. Essen. 5000 Jahre, No. 145 with Abb. See Brussels. 5000 ans, p. 31 [79] (as Ptolemaic).

Tutu as sphinx, Roman, formerly in Abbott and N.Y. Hist. Soc. Collns., now in Brooklyn Mus. 37.1509E. COONEY, *Late Egyptian and Coptic Art*, pl. 8, p. 16; id. in *Brooklyn Mus. Bull.* x [3] (Spring 1949), fig. on p. 23; SAUNERON in *J.N.E.S.* xix (1960), pls. xi, xii, pp. 274 [50], 276. See BONOMI, *Cat. Colln. Abbott*, p. 4 [37]; *N.Y.H.S. Cat.* p. 9 [133].

Trial-pieces, etc. Late Period or Ptolemaic. In Cairo Museum.

Plaster-mask of a King, CG 1185. BORCHARDT, *Statuen*, iv, Bl. 166, p. 92.

Two royal heads, CG 33332, 33362. EDGAR, *Sculptors' Studies and Unfinished Works (Cat. Caire)*, pls. ix, xvi, pp. 13–14, 40; PRISSE, *L'Art ég.* ii, *Sculpture*, 31st pl. [8, 2], 'Études de têtes' [etc.], *Texte*, p. 408.

Two royal heads, CG 33350, 33358. EDGAR, op. cit. pls. xiii, xv, pp. 30–1, 37–8; WEIGALL, *Anc. Eg. . . . Art*, 332 [lower]. CG 33350, PRISSE, op. cit. 31st pl. [3], *Texte*, p. 408.

Royal heads, CG 33331, 33333, 33348, 33351, 33353, 33356, 33359–61, 33363–4. EDGAR, op. cit. pls. ix, xiii–xvi, pp. 12–13, 14, 28–9, 31–3, 33–4, 36–7, 38–40, 40–2.

Royal head. PRISSE, op. cit. 31st pl. [4], 'Études de têtes' [etc.], *Texte*, p. 408.

Half royal head, CG 33352. Id. ib. 31st pl. [1], *Texte*, p. 408; EDGAR, op. cit. pl. xiii, p. 33. See MASPERO, *Guide*, p. 497 [4801].

Stelae.

Upper part, double-scene, King Ḥaremḥab before Osiris, probably from here, in Cairo Mus. Temp. No. 22.5.25.2. Text, DARESSY in *Ann. Serv.* xvii (1917), p. 85; HELCK, *Urk.* iv. 2129 [830], cf. *Übersetz.* (1961), p. 410; HARI, *Horemheb*, pl. xlix (from DARESSY), p. 293.

A Ptolemy (names erased) before bull-headed god  and Theban triad, in Cairo Mus. CG 22161. KAMAL, *Stèles Ptolémaïques et Romaines (Cat. Caire)*, pl. xlix, pp. 146–7; LANZONE, *Diz.* Tav. cxxxv [lower]. Texts of gods, BRUGSCH, *Dictionnaire Géographique de l'Ancienne Égypte*, pp. 201–2 (as Mît Ghamr). See HABACHI in *Ann. Serv.* liii (1956), p. 462.

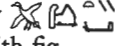





Paṣahaty  before Sēth, votive stela, faience, Ramesside. BAKRY in ib. lvii (1962), pp. 7–8 with fig.

Blocks, etc.

Pyramid-text fragment, end of Dyn. V or Dyn. VI, in Berlin Mus. 7727. Text, *Aeg. Inschr.* i, p. 4. See *Ausf. Verz.* p. 44.

Horus-name of Pepy I, in Basel, Mus. für Völkerkunde, III.5220. HORNING in *So lebten die Alten Ägypter* (Sonderausstellung 1976–7), fig. 3 on p. 12. See RÜTIMEYER,

Führer durch das Museum für Völkerkunde Basel, Alt-Ägypten (1930), p. 17; id. *Bericht* (1921) in *Verhandlungen der Naturforschenden Gesellschaft in Basel*, xxxiii, p. 3.

Block of Senbef      , Prophet, Inspector of sem-priests of Sokari, son of Imes , Lector-priest, probably trial-piece, Dyn. VI (James) or Middle Kingdom (Simpson), formerly in Abbott and N.Y. Hist. Soc. Collns., now in Brooklyn Mus. 37.1355E. WILKINSON MSS. xli. 43 verso [bottom right]. Text, JAMES, *Corpus*, i, pl. xxv [65], p. 27. See BONOMI, *Cat. Colln. Abbott*, p. 2 [8]; *N.Y.H.S. Cat.* p. 14 [183]; SIMPSON in *A.J.A.* 79 (1975), p. 153 [65]; DE MEULENAERE in *Chron. d'Ég.* xlix (1974), p. 270.

Lintel of Ramesses III, in Brit. Mus. 1344. See *Guide (Sculpture)*, p. 198 [717].

Trial-pieces, etc. Late Period or Ptolemaic. In Cairo Museum.

Winged goddess, head of jackal, Apis-bull, ram, man's head, CG 33413, 33425, 33437, 33444, 33489. EDGAR, *Sculptors' Studies and Unfinished Works (Cat. Caire)*, pls. xxvi, xxviii, xxxii, xlili (excluding CG 33444), pp. 58, 61, 66, 69, 82. *Recto* of CG 33437, KATER-SIBBES and VERMASEREN, *Apis, I*, p. 12 [31] with pl. xxiii.

Forepart of ram, CG 33443. EDGAR, *op. cit.* pl. xxxiii, p. 69; PRISSE, *L'Art ég.* ii, *Sculpture*, 36th pl. [top], 'Animaux' [etc.]; MARIETTE, *Album du Musée de Boulaq* (1872), pl. 24 [683]; DE ROUGÉ, *Album photo.* pl. 137; WEIGALL, *Anc. Eg. . . . Art*, 329 [lower left]; CAPART, *Propos*, fig. 44 [left]; KEIMER in *Ann. Serv.* xxxviii (1938), fig. 39, p. 316.

Vessels.

Alabaster jar of Tuthmosis III, 21 hin, in Cairo Mus. CG 18734. VON BISSING, *Steingefässe (Cat. Caire)*, Taf. iv, pp. 156-7; MARIETTE, *Mon. div.* pl. 100 [lower]. Text, LEGRAIN, *Répertoire*, No. 145; LUCAS and ROWE in *Ann. Serv.* xl (1940), pp. 87 [7], cf. 78-9 [vii]. See DARESSY in *Bull. Inst. Ég.* iii Sér. 8 (1897), p. 151 [1]; MASPERO, *Guide*, p. 542 [5510].

Alabaster vase of Tuthmosis III and Queen Siti'oḥ, 16 hin. Text, WILKINSON MSS. xxii. 38.

Others.

Alabaster model sistrum of Teti 'beloved of Hathor Mistress of Dendera', in New York, M.M.A. 26.7.1450. DAVIES (N. DE GARIS) in *J.E.A.* vi (1920), pl. viii, pp. 69-72; HAYES, *Scepter*, i, fig. 76; HICKMANN, *45 Siècles*, pl. lxxxviii [A, B]; FISCHER, *Dendera in the Third Millennium B.C.* [etc.], frontispiece, p. 37; HORNEMANN, *Types*, vi, pl. 1568; KAYSER, *Ägyptisches Kunsthandwerk*, Abb. 65; SÉE, *Naissance*, fig. on p. 203. Upper part, PIJOÁN, *Summa Artis*, iii (1945), fig. 214. See *Burlington Fine Arts Club. Catalogue of an Exhibition of Ancient Egyptian Art* (1922), p. 90 [39].

Two alabaster tablets from foundation deposit of Psammetikhos I, formerly in N.Y. Hist. Soc. Colln., now in Brooklyn Mus. 37.465E. See *N.Y.H.S. Cat.* p. 41 [646-7].

Weight of 300 deben in shape of cow's head, with cartouches of Sethos I, granite, in Cairo Mus. CG 31651. WEIGALL, *Weights and Balances (Cat. Caire)*, pl. iii, p. 55; text, KITCHEN, *Ram. Inscr.* i. 125 [66]. See MASPERO, *Guide*, p. 542 [5512].

Terminal of handle of model axe with cartouche of Amenophis III, lapis lazuli, formerly in N.Y. Hist. Soc. Colln., now in Brooklyn Mus. 37.280E. Text, JAMES, *Corpus*, i, pl. lxxxix [252d], p. 111. See *N.Y.H.S. Cat.* p. 38 [592].

EL-‘AZÎZÎYA

Offering-table of Tuthmosis IV, granite, in Cairo Mus. CG 23088. Text, KAMAL, *Tables d'offrandes (Cat. Caire)*, p. 72; HELCK, *Urk.* iv. 1558 [493], cf. *Übersetz.* (1961), p. 149. See GAUTHIER in *Ann. Serv.* x (1910), p. 201 [upper].

Cylinder seal of Menkheperre (probably Tuthmosis III), showing Asiatic influence. CHASSINAT in *B.I.F.A.O.* viii (1911), fig. 1, pp. 145-8.

MÎT RAHÎNA

Map LXXI

Plan, L. D. i. 9, *Text*, i, pp. 202-4; PETRIE, *Memphis*, i, pl. i; DIMICK (J.) in ANTHES, *Mit Rahineh* 1955, map at end, pp. 81-3 (also published separately); WILKINSON MSS. xiii. 39; BURTON MSS. 25620, 9, with description, 25618, 82, 83, 84, 86, 88.

Northern Enclosure

PALACE OF APRIES.

KEMP in *Mitt. Kairo*, 33 (1977), pp. 101-8, with plan and sections, figs. 1, 2, and views, Taf. 28-30. Plan, PETRIE, *Memphis*, ii, pl. i. Views, including some showing palm-capitals, id. ib. ii, pls. x-xiii, pp. 1-5; DIMICK (M. T.), *Memphis, the City of the White Wall*, 13th-15th pls.; SÉE, *Naissance*, fig. on pp. 158-9.



Palm-capitals. (a) Copenhagen, Ny Carlsberg Glypt. Æ.I.N. 1045, MOGENSEN, *Coll. ég.* pl. cxi [A 747], p. 103; see KOEFOED-PETERSEN, *Cat. des bas-reliefs*, pp. 60-1 [81]. (b) Munich, Staatl. Samml. ÄS 79, VON BISSING in *Münchner Jahrb.* (1911), Abb. 13, p. 170 [19]; see WOLTERS, *Führer* (1923), p. 54 [82]; (1928), p. 55 [82].

Column-fragment with cartouche of Apries, in Bristol, City Mus. H 648. PETRIE, op. cit. ii, pl. xix [bottom right], pp. 3, 14. See GRINSELL, *Guide Catalogue to the Collections from Ancient Egypt* (1972), p. 59.

Blocks from thicknesses of gate in destroyed pylon, three registers on each side with unnamed king in *heb-sed* ceremonies, Dyn. XXVI. PETRIE, op. cit. ii, pls. ii [1-3, 6, 7], iii-ix, pp. 5-11; iii, pl. xxxi [top right and upper middle right]. Left thickness: **I**, in Liverpool, Merseyside County Museums, 10.9.09.1, 2, see *Handbook and Guide to the Egyptian Collection* [etc.] (1932), p. 39 [5]; **II**, right side, in Oxford, Ashmolean Mus. 1909.1154 (for other blocks see right thickness, **II**); **III**, in Cairo Mus. JE 41436. Right thickness: **I**, in Copenhagen, Ny Carlsberg Glypt. Æ.I.N. 1046, MOGENSEN, *Coll. ég.* pl. cii [A 703], p. 95; CAPART, *Documents*, ii, pls. 88-9; id. *L'Art ég.* iii, pl. 593; KOEFOED-PETERSEN, *Cat. des bas-reliefs*, pl. lv [55], pp. 45-6; PIRENNE, *Hist. civ.* iii, pls. 32-3 after p. 140; head of king, PETRIE, *Arts and Crafts*, fig. 6 facing p. 14; **II**, new reconstruction, SÄVE-SÖDERBERGH, *On Egyptian Representations of Hippopotamus Hunting as a Religious Motive in Horae Soederblomianae*, iii (1953), fig. 13, pp. 49-53; KEES in *Studi Rosellini*, ii, Tav. xv, p. 149; block mentioning Festival of the White Hippopotamus, in Brussels, Mus. Roy. E.5036, DE WIT in *Chron. d'Ég.* xxxiii (1958), fig. 4, pp. 25-8; text, SPELEERS, *Rec. inscr.* p. 86 [320]; rest in New York, M.M.A. 09.183.1; **III**, two fragments in London, Univ. Coll. 15858-9.

Three fragments of texts, in Copenhagen, Ny Carlsberg Glypt. Æ.I.N. 1048-50. MOGENSEN, *Coll. ég.* pl. ci [A 701], pp. 94-5; two, PETRIE, op. cit. ii, pl. ii [4, 5], p. 5.

Bronze corner of door of Psammetikhos II, in Edinburgh, Roy. Scot. Mus. 1910.155. Id. ib. iii, pls. xxxii [3], xxxiii [13], p. 40; RUFFLE, *Heritage of the Pharaohs*, fig. 134 [upper].

Door-jamb of Thaiēsîmu , Royal scribe, Royal herald, etc., *recto*, Thaiēsîmu and text mentioning ‘Aḥmosi-sineit , Overseer of the antechamber, temp. Amasis to Dyn. XXVII, *verso*, Thaiēsîmu suckled by goddess Semset, temp. Nektanebos I, re-used, in Cambridge, Fitzwilliam Mus. E.5.1909; PETRIE, *op. cit.* ii, pls. xvii, xxv [right], pp. 13, 20-1; Thaiēsîmu on *recto*, id. *Arts and Crafts*, fig. 9 facing p. 20; PIRENNE, *Hist. civ.* iii, pl. 34 facing p. 141; see SCHARFF in *Ä.Z.* 74 (1938), p. 44, cf. Abb. 2. Companion-piece, in Brooklyn Mus. 56.152, see *infra*.

Blue glazed bowl fragment of Teos, in London, Univ. Coll. 15991. PETRIE, *Memphis*, ii, pl. xiv [bottom right], p. 12; id. *Scarabs and Cylinders*, pl. lvii [30.2].











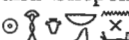

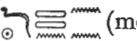

Ivory inlay, man with birds, Late Period, in Edinburgh, Roy. Scot. Mus. X.294.3. Id. *Memphis*, ii, pl. xiv [middle right], p. 12; id. *Arts and Crafts*, fig. 126 facing p. 136.

Clay sealings. Id. *Memphis*, iii, pls. xxxv [1-21], xxxvi [1-21], xxxvii [42, 47-9], pp. 42-3.

‘CAMP’. Plan of gate, PETRIE, *Memphis*, i, pl. xxx [left].

Two blocks from east of Palace, one of them with names of Ay, now in Boston Mus. 09.641, the other with Sekhmet and a king, perhaps same date, in Rochdale Mus. Id. *ib.* ii, pl. xix [top middle, and right], p. 14.

Embalming-bed of Amenhotp, Chief steward, temp. Amenophis III (Şaqqâra tomb, see *supra*, pp. 702-3), alabaster, from south of Palace. HABACHI in *Mitt. Kairo*, 22 (1967), Taf. x, xi, figs. 1, 2, pp. 42-7.

Bronzes, including [Nos. 1-13 of Daressy] plaques with king or Nile-god offering and names of Tuthmosis III, Osorkon III, Kashta, Psammetikhos II, Amasis, Amenardais I, and Shepenwept I or II, [Nos. 14-16] three oval plaques dedicated by Wehebrēc-nebken , son of Psammethek-tancit , both Commanders of the army, temp. Psammetikhos II, Piamūn , son of Harbes , and unnamed, [Nos. 17-22] mirrors, including [No. 17] Mutardais , daughter of Thai-pautitai-imu  (mother), [No. 18] Irterau , daughter of Riri  and Taherib , [No. 19] Kequiry , daughter of Menamenrēc  (mother), [No. 20] Thesmutpert , daughter of Amen(em)ōpet , [No. 21] Esinḥertardais , daughter of Pedeharsemtu  and Heribi , mostly 3rd Int. Period or Dyn. XXVI, originally presumably from Thebes, found probably here, in Cairo Mus. JE 35107 (mirrors CG 44076-80), and Temp. Nos. 27.11.26.3, 4. DARESSY in *Ann. Serv.* iii (1902), pls. i-iii (some), pp. 139-50. Nos. 1, 2, 6, MASPERO, *Égypte*, figs. 560-2. Cartouches of Tuthmosis III on No. 7, LEGRAIN, *Répertoire*, No. 152. Incomplete top registers of Nos. 14 and 15, WAINWRIGHT in *Ann. Serv.* xxviii (1928), figs. 2, 3, p. 179; cloaked image, see DORESE in *Rev. d'Ég.* 25 (1973), pp. 101-4 [15, 16], cf. fig. 1 (from DARESSY). Nos. 17-21, BÉNÉDITE, *Miroirs (Cat. Caire)*, pls. xvi-xx, pp. 36-41; MUNRO in *Ä.Z.* 95 (1968-9), Taf. ii-vi (from BÉNÉDITE), pp. 92-3, 97-100. See MASPERO, *Guide*, pp. 457-8 [4340-51]; DANINOS PACHA in *Ann. Serv.* v (1904), pp. 142-3; KEMP in *Göttinger Miszellen*, No. 29 (1978), p. 61.

Ptaḥ Enclosure with Dependencies

TEMPLE OF PTAḤ. Ramesses II

Plan, PETRIE, *Memphis*, i, pl. ii; DARESSY in *Ann. Serv.* iii (1902), fig. 1, pp. 22-4; with

sections, HAENY, *Basilikale Anlagen in der ägyptischen Baukunst des Neuen Reiches in Beiträge zur ägyptischen Bauforschung*, 9, Abb. 27a, b, pp. 69–70. Views, PETRIE, *op. cit.* i, on pls. xxi–xxiii, pp. 5–6; ROBICHON and VARILLE, *En Égypte* (1937), pl. 32; (1955), pl. 27; KEES, *Das alte Ägypten* (1955), Abb. 28; (1958), Abb. 34; Eng. ed. *Ancient Egypt* (1961), pl. 16 [b]; WESTENDORF, *Das Alte Ägypten*, fig. on p. 167; JAMES, *The Archaeology of Ancient Egypt*, fig. on p. 111; DIMICK (M. T.), *Memphis, the City of the White Wall*, 2nd pl.; TADEMA and TADEMA SPORRY, *De Pyramiden van Egypte*, pl. 1.

COLOSSI IN FRONT OF PYLON.

Fragments of statues of Ramesses II, red granite, alabaster, and limestone; PETRIE, *Memphis*, i, pl. xxiii [top right, and middle], pp. 5, 9–10. Two red granite heads, in Cairo Mus. CG 643–4; BORCHARDT, *Statuen*, ii, Bl. 118, pp. 188–9; see MASPERO, *Guide*, p. 182 [671–2]; id. and ROEDER, *Führer*, p. 50 [612–13]. Texts of limestone colossus, DARESSY, *op. cit.* p. 25 [near bottom].

Basalt base of colossus of Ramesses II with name-rings, standing in advance of Pylon. PETRIE, *op. cit.* i, pl. xxiii [bottom], p. 10. See DARESSY, *op. cit.* pp. 24 [bottom]–25 [top].

Found in front of Pylon.

Endowment stela of Ameny  Chief Justice and Vizier, granite, temp. Sesostri I. Part of text, PETRIE, *op. cit.* i, pl. v, pp. 6–7, 17–18.

Three fragments of quartzite stela with coronation-text of Haremḥab (for other copies see *Bibl.* ii². 6 and Turin Mus. Cat. 1379). Texts, DARESSY, *op. cit.* pp. 27–8 [1–3]; HARI, *Horemheb*, pls. xxxviii, xxxix [upper] (from DARESSY and PETRIE), pp. 214–17. Fragment I, PETRIE, *op. cit.* i, pl. vi, pp. 7, 18; HELCK, *Urk.* iv. 2121–4 [826], cf. *Übersetz.* (1961), pp. 407–8; see GARDINER in *J.E.A.* 39 (1953), pp. 14, 28–31. Fragment III, PETRIE, *op. cit.* i, pl. xxvi [2], pp. 10, 20. See NEWBERRY in *Anc. Eg.* (1925), p. 4.

Two inscribed basalt blocks. Text, DARESSY, *op. cit.* p. 28 [4]; KITCHEN, *Ram. Inscr.* ii. 492 [190, 3]; of one, PETRIE, *op. cit.* i, pl. xxiv [lower], p. 10.

Foundation deposit of Ramesses II and son Kha'emwëset, in Manchester Mus. 4947–51; id. *ib.* i, pl. xix [lower left] (two objects not illustrated), p. 8; texts, KITCHEN, *Ram. Inscr.* ii. 493 [190, 6]; see GOMAA, *Chaemwese* [etc.], pp. 82–3 [45], cf. Abb. 16 [a]. Sandstone block and faience plaque of Ramesses II and Kha'emwëset, probably from here, in Brit. Mus. 48664, 49235; see WEINSTEIN, *Foundation Deposits in Ancient Egypt*, p. 258 [89, B]; GOMAA, *op. cit.* p. 83 [46–7]; No. 48664, text, SHORTER in *Studies Presented to F. Ll. Griffith*, p. 132; see *Guide*, 4th to 6th, p. 292 [61].^a Faience plaque of Ramesses II, perhaps from here, in Brit. Mus. 49234.

PYLON.

Cartouches of Setnakht, PETRIE, *Memphis*, i, pl. xxvi [7], p. 10; KITCHEN, *Ram. Inscr.* v. 3 [4, e]; see DARESSY, *op. cit.* pp. 25 [bottom]–26 [top].

Doorway. Jambs, outer, Ramesses II offering to Sekhmet and to Ptaḥ, inner, names and titles of the King; text, id. *ib.* p. 26 [near top and middle]; KITCHEN, *Ram. Inscr.* ii. 488 [190, 1]. Bottom of one thickness, names and titles of Merneptah and Ramesses III; PETRIE, *op. cit.* i, pl. xxii [top], p. 9; FISCHER in *Artibus Asiae*, xxiv [1] (1961), fig. 3 on p. 50; text, DARESSY, *op. cit.* pp. 26 [bottom]–27 [top].

HYPOSTYLE HALL WITH NORTH AND SOUTH CORRIDORS. 'West Hall.'

Texts, KITCHEN, *Ram. Inscr.* ii. 487–8 [189], 492–3 [190, 4].



Architectural elements of Ramesses II. Fragments of columns, PETRIE, *Memphis*, i, pls. xx [21], xxii [bottom right], p. 9; texts of two, DARESSY in *Ann. Serv.* iii (1902), p. 29 [7, 10]. Drums of granite columns, PETRIE, op. cit. i, pl. xxv [lower right], p. 10; SOGA, *The Nile*, fig. on p. 174 [right]; see DARESSY, op. cit. p. 29 [9]. Block with head of Ptaḥ and names of the King, granite, PETRIE, op. cit. i, pl. xxiv [upper], p. 10; cf. DARESSY, op. cit. p. 30 [15]. Texts of others, id. ib. pp. 28 [5], 30 [11-14, 16].

Column-fragments of Sethos II, quartzite. Texts, id. ib. pp. 30-1 [17].

False-door fragments of Ramesses II, granite. PETRIE, op. cit. i, pl. xx [22], pp. 8-9.

Finds



Statues.



Raꜣy   , Royal scribe, Overseer of the Two Granaries, etc., lower part, temp. Amenophis III, in Dublin, National Mus. 1908.514. PETRIE, *Memphis*, i, pl. xix [right], p. 8. See MURRAY, *General Guide to the Art Collections*, iii, *Egyptian Antiquities*, p. 65.



Two colossal statues of Ptaḥ dedicated by Ramesses II, sandstone, in Cairo Mus. CG 38429-30. DARESSY, *Statues*, pl. xxv, pp. 116-17; GRIFFITH INST. photo. 387 (*in situ*); MASPERO, *Guide* (1914), pp. 168-9 [662-3] with fig. 48; (1915), p. 268 [1295-6] with fig. 95 (both figs. CG 38429); id. and ROEDER, *Führer*, p. 50 [390-1] with Taf. 20 [a] (CG 38429). CG 38429, CAPART, *Memphis*, fig. 208; COOK in HAMMERTON, *Universal History of the World*, i, fig. on p. 645 [near right]; ROEDER, *Die ägyptische Götterwelt*, Taf. 2 [a]. CG 38430, MASPERO, *Égypte*, fig. 368. Texts, DARESSY in *Rec. Trav.* xiv (1893), p. 174 [lxviii]; KITCHEN, *Ram. Inscr.* ii. 493 [190, 5].









Votive stelae.





Texts of some, PETRIE, *Memphis*, i, pl. xv [bottom].

ʿAḥmosi  , New Kingdom. (a) Bristol Mus. H 2218B, id. ib. i, pl. xvi [43], pp. 8, 20. (b) Hanover Mus. 1935.200.199, id. ib. i, pl. xvi [44], pp. 8, 20.

Beken[rēꜥ]   , Custodian of the gate, with Tuthmosis I offering to Ptaḥ and Sekhmet, in Edinburgh, Roy. Scot. Mus. 1908.361. Id. ib. i, pl. vii [46], p. 7.



Huy  , Chariot-warrior, Dyn. XIX, in Edinburgh, Roy. Scot. Mus. 1908.360. Id. ib. i, pl. xvii, pp. 8, 20.

Ken   and Merenptah      , Ramesside, in New York, M.M.A. 08.205.2C. Id. ib. i, pl. xv [40], p. 8.

Mer(y)rēꜥ    , Scribe of Memphis(?), Ramesside, in Philadelphia Mus. E 12509. Id. ib. i, pl. xiv [31], pp. 8, 19.

Nehia    (woman), Dyn. XIX, in Manchester Mus. 4911. Id. ib. i, pls. vii [lower right], xvi [42], pp. 8, 20.

Raꜣmosi, Head of serfs, temp. Tuthmosis IV. (a) Brussels, Mus. Roy. E.4499, id. ib. i, pls. vii [upper left], viii [4], p. 19; text, SPELEERS, *Rec. inscr.* p. 37 [134]; names of Ptaḥ and King, HELCK, *Urk.* iv. 1563 [502], cf. *Übersetz.* (1961), p. 152. (b) Hanover Mus. 1935.200.229, PETRIE, op. cit. i, pls. viii [3], ix [lower middle right], pp. 7, 18-19. (c) Edinburgh, Roy. Scot. Mus. 1908.362, id. ib. i, pl. xv [36], pp. 8, 19.



Rēꜥ   , Dyn. XVIII, formerly in New York, M.M.A. 08.205.2A. Id. ib. i, pl. xiv [33], p. 8.

Name unknown, with King [Merneptah] before Ptaḥ and Astarte, fragment, in London, Univ. Coll. 14392. Id. ib. i, pl. xv [37], pp. 8, 19; STEWART, *Eg. Stelae*, i, pl. 41 [2], p. 51; LECLANT in *Syria*, xxxvii (1960), fig. 1, pp. 10-13.

Others. Copenhagen, Ny Carlsberg Glypt. Æ.I.N. 1014-15, PETRIE, op. cit. i, pls. xvi [41], xiv [32], pp. 8, 20; MOGENSEN, *Coll. ég.* pls. cv [A 713], cviii [A 728], pp. 97, 100; SCHMIDT, *Choix* (1910), pl. xv [33-4], p. 29; Æ.I.N. 1014, KOEFOED-PETERSEN, *Ægyptens Guder*, pl. 18; Æ.I.N. 1015, id. *Les stèles égyptiennes*, pl. 39, p. 33. London, Victoria and Albert Mus. 423-4.1908, PETRIE, op. cit. i, pl. vii [lower left], viii [1], p. 7. London, Univ. Coll. 14396-7, id. ib. i, pls. xiv [35], xv [38], pp. 8, 19; STEWART, op. cit. pl. 29 [3, 5], p. 37. Philadelphia Mus. E 12508, PETRIE, op. cit. i, pl. xiv [34].

Ear-stelae.

Amenmosi, Ramesside, in Manchester Mus. 4906. PETRIE, *Memphis*, i, pls. ix [top near right], x [10], pp. 7, 19.

Iay , Head of quarrymen, and Huy , Door-opener of the door of the tomb, Ramesside, in Brussels, Mus. Roy. E.4498. Id. ib. i, pl. xii [21], pp. 7, 19. Text, SPELEERS, *Rec. inscr.* p. 47 [167]. See DE MEULENAERE, *Het leven na de dood in het Oude Egypte* (Tentoonstelling van 21 juni tot 28 september 1969. Provinciaal Gallo-Romeins Museum—Tongeren), No. 69.

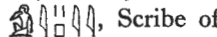
Ipy , Scribe of meat-offerings of Amūn, Ramesside, formerly in New York, M.M.A. 08.205.2E. PETRIE, op. cit. i, pl. xi [19], p. 7.

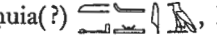
Mahūia(?) , Ramesside, in Brit. Mus. 1471. Id. ib. i, pl. xiii [30], pp. 7, 19. See *Guide (Sculpture)*, p. 304 [1171].

Ptaḥmosi, Head of sculptors, Ramesside, in Manchester Mus. 4909. PETRIE, op. cit. i, pls. ix [49], xiii [middle], pp. 7, 19.

Raḥmosi, Scribe of the Treasury of the Lord of the Two Lands, and wife Tentiunu , Ramesside. Id. ib. i, pl. xi [20], pp. 7, 19.

Others, Ramesside. Bristol Mus. H 2218A, id. ib. i, pl. xi [16]; see GRINSELL, *Guide Catalogue to the Collections from Ancient Egypt* (1972), p. 49. Brussels, Mus. Roy. unnumbered, PETRIE, op. cit. i, pls. ix [top right], xii [25], pp. 7, 25. Copenhagen, Ny Carlsberg Glypt. Æ.I.N. 1016-17, id. ib. i, pls. ix [top near left], xi [18], xiii [26], p. 19; MOGENSEN, *Coll. ég.* pl. cv [A 711-12], p. 97; SCHMIDT, *Choix* (1910), pl. xv [32, 31], pp. 29-30; KOEFOED-PETERSEN, *Les stèles égyptiennes*, pl. 40, p. 33. Dublin, National Mus. 1908.518-19, PETRIE, op. cit. i, pls. ix [upper middle left], x [12], xiii [29], p. 19; see MURRAY, *General Guide to the Art Collections*, iii, *Egyptian Antiquities*, p. 66. Edinburgh, Roy. Scot. Mus. 1908.363, PETRIE, op. cit. i, pl. xi [17]. Hanover Mus. 1935.200.204 (formerly The Hague, Scheurleer Mus.), id. ib. i, pl. viii [2], p. 7. Brit. Mus. 1472 and another, id. ib. i, pls. ix [upper middle near right and top left], x [14, 5], p. 7; see *Guide (Sculpture)*, p. 304 [1172]. London, Univ. Coll. 14398, 14394, 14393, 14395, PETRIE, op. cit. i, pls. ix [48], x [8, 9], xii [24], p. 7; STEWART, *Eg. Stelae*, i, pl. 29 [4, 6] (14398, 14395), pp. 37-8. Manchester Mus. 4905, 4907-8, PETRIE, op. cit. i, pls. x [6], xiii [27-8], p. 7. Philadelphia Mus. E 12506-7, id. ib. i, pls. x [11], ix [lower middle near left], xii [23], pp. 7, 19. Rochdale Mus., id. ib. i, pl. xi [15], pp. 7, 19. Formerly in New York, M.M.A. 08.205.2D, id. ib. i, pls. ix [lower middle near right], xii [22]; No. 08.205.2B, then Legg Colln., id. ib. i, pl. x [13].

Blocks. Re-used.

Five offering-bringers, Dyn. V-VI, in Brussels, Mus. Roy. E.5297. PETRIE, *Memphis*, i, pl. iii [left top], p. 6. See DE MEULENAERE, *Het leven na de dood in het Oude Egypte* (Tentoonstelling van 21 juni tot 28 september 1969. Provinciaal Gallo-Romeins Museum—Tongeren), No. 40.

Lintel and jambs of Neuserrêc, granite, from Sun-temple at Abû Ghurâb (*Bibl.* iii². 314-24), in Cairo Mus. Temp. Nos. 22.11.14.17-19. Lintel and one jamb, PETRIE, *op. cit.* i, pl. iii [middle and left bottom], p. 6.

Lintel of King Teti. *Id. ib.* i, pl. iii [right bottom], p. 6. Text, DARESSY in *Ann. Serv.* iii (1902), p. 29 [6].

God with shrine, Old Kingdom. PETRIE, *op. cit.* ii, pl. xviii [upper left], p. 13.

Jamb with remains of text mentioning Ramesses II, in Hanover Mus. 232. *Id. ib.* i, pl. xxvi [left], p. 10.

Three blocks, New Kingdom, (a) tree, in Brussels, Mus. Roy. E.7546, (b) upper part of god, in Rochdale Mus., (c) child on bull's head, in New York, M.M.A. 08.205.12. *Id. ib.* i, pl. xxvi [3-5], p. 10.

Offering-tables.

Wahka ꜥꜣ, Count, Overseer of prophets, early(?) Dyn. XII, granite. PETRIE, *Memphis*, i, pl. iv, p. 6.

Amenhotp, Chief steward in Memphis, temp. Amenophis III (Şaqqâra tomb, see *supra*, pp. 702-3), in New York, M.M.A. 08.205.3. *Id. ib.* i, pls. ix [bottom right], xviii, p. 8, 20. Text, HELCK, *Urk.* iv. 1804 [646], cf. *Übersetz.* (1961), p. 264.

Various.

Model bark, granite, Dyn. XIX, in Cairo Mus. CG 4924. REISNER, *Models of Ships and Boats (Cat. Caire)*, pl. xix, pp. 82-3; GÖTTLICHER and WERNER, *Schiffsmodelle im Alten Ägypten*, Taf. xvii [2]. See MASPERO, *Guide*, p. 168 [590].

Model bark with naos and statues of gods, incomplete, Dyn. XIX, in Cairo Mus. CG 4930. REISNER, *op. cit.* pls. xx, xxi, pp. 91-2. See MASPERO, *op. cit.* p. 168 [591].

EXTERIOR OF HYPOSTYLE HALL.

Base of north and south walls, geographical processions. North, MARIETTE, *Mon. div.* pl. 31; eight figures, BRUGSCH, *Dictionnaire Géographique de l'Ancienne Égypte*, p. 270; two, PETRIE, *Memphis*, i, pl. xxi [bottom left], p. 9; four names, BRUGSCH in *Ä.Z.* x (1872), p. 20; see YOYOTTE in *B.I.F.A.O.* lxi (1962), pp. 82-8, cf. 80-2. South, *id. ib.* pl. vii, pp. 88-9, cf. 80-2; three figures, PETRIE, *op. cit.* i, pl. xxi [near bottom left]; four names, DARESSY in *Ann. Serv.* iii (1902), p. 27 [middle]. Texts of both, KITCHEN, *Ram. Inscr.* ii. 488-92 [190, 2]. Sketch, possibly from here, WILKINSON MSS. xiii. 36 [lower]. Block re-used in Monastery of Apa Jeremias at Şaqqâra, see *supra*, p. 667.

Found nearby

Statue of Ramesses II and Ptaḥ-tatanen seated, granite, in Cairo Mus. CG 554. BORCHARDT, *Statuen*, ii, Bl. 93, pp. 101-2; HORNEMANN, *Types*, iv, pl. 1119; GRIFFITH INST. photo. 386. See MASPERO, *Guide*, p. 169 [597].

Bust, with scarab on head, probably Ramesses II (no text), granite, in Cairo Mus. CG 38104. See DARESSY, *Statues*, p. 35; MASPERO, *Guide*, p. 188 [731].

Headless sphinxes holding vase, of Ramesses II, sandstone. (a) PETRIE, *Memphis*, vi, pl. lviii [30], p. 33. (b) Cairo Mus. CG 1211, probably from here; BORCHARDT, *Statuen*, iv, Bl. 170, p. 110; text, KITCHEN, *Ram. Inscr.* ii. 497 [193, D]; see MASPERO, *Guide*, p. 161 [553].

ENCLOSURE WALL

NORTH GATE.

Lintel of Amenemhêt III, quartzite. PETRIE, *Memphis*, v, pl. lxxvii [top], p. 32.

Colossal double-statue, Ramesses II and Ptaḥ, granite, in Copenhagen, Ny Carlsberg Glypt. Æ.I.N. 1483. Id. ib. v, pls. lxxvii [lower], lxxviii [middle right], p. 32; MOGENSEN, *Coll. ég.* pl. vii [A 14], p. 8; KOEFOED-PETERSEN, *Det gamle Ægypten* (1943), fig. on p. 18; id. *Ægyptisk Billedhuggerkunst* (1938), pl. 29; (1951), pl. 31; id. *Eg. Sculpture* (1951), pl. 33; (1962), pl. 35; id. *Cat. des statues*, pls. 68-9, pp. 34-5 [58]; CAPART in *Fra Ny Carlsberg Glyptotekets Samlinger* (1920), fig. 4, p. 46; MURRAY, *Sculpture*, pl. xxv [1]; *Capolavori*, i, No. 12 (1963), fig. on p. 185 [lower]; Eng. ed. fig. on p. 177 [lower]; upper part, FRANCESCHI and JOHANSEN, *Et hundrede fire og tyve fotografier*, pl. 17. Text, KITCHEN, *Ram. Inscr.* ii. 486-7 [188]. See BAGNOLD in *P.S.B.A.* x (1888), p. 458 [middle]; CHRISTOPHE in *Bull. Inst. Ég.* xxxvii (1954-5), p. 7 note 1.

Sphinx of Ramesses II, usurped by Merneptah, granite, in Philadelphia Mus. E 12326. PETRIE, *Memphis*, v, pl. lxxviii [top], pp. 32-3; vi, pl. lvi [19, 20], p. 33; E. H. H[ALL] in *Penn. Mus. Journ.* v (1914), figs. 24-6, pp. 49-54; vi (1915), fig. 63 on p. 83; xvii (1926), figs. on pp. 107 [right], 115; RANKE in *Penn. Mus. Bull.* xv [2-3] (Nov. 1950), on fig. 59, pp. 101-2; RAINEY in ib. 18 [4] (Nov. 1954), on fig. on p. 26; O'CONNOR and SILVERMAN in *Expedition*, 21 [2] (Winter 1979), on fig. 64 on p. 42.

Scribe-statue (headless) of Amenhotp, Chief steward, etc. (Šaqqâra tomb, see *supra*, pp. 702-3), quartzite, temp. Amenophis III, in Oxford, Ashmolean Mus. 1913.163. PETRIE, *Memphis*, v, pls. lxxviii [bottom right], lxxix, lxxx, pp. 33-6 (translation by Gardiner). Text, HELCK, *Urk.* iv. 1793-1801 [642], cf. *Übersetz.* (1961), pp. 259-63. See HAYES in *J.E.A.* 24 (1938), pp. 12 [P], 18-19, 20-1; BOTHMER in *Boston Mus. Bull.* xlvii (1949), pp. 48-9 with fig. 10 (from PETRIE). (The statue does not join Boston Mus. 29.729.)

Head, probably Late Period, in Copenhagen, Ny Carlsberg Glypt. Æ.I.N. 1480. PETRIE, *Memphis*, v, pl. lxxviii [middle left], p. 33.

SOUTH GATE.

Colossi.

Ramesses II, with daughter in relief by left leg, limestone, 'Abû el-Ḥôl'. L. D. i. 10 and iii. 142 [e-h], cf. *Text*, i, p. 204; ROSELLINI, *Mon. Stor.* lxxvi [1, 2]; BRUGSCH, *Recueil*, pl. i; PRISSE, *L'Art ég.* ii, *Sculpture*, 43rd pl., 'Colosse de Ramsès II', *Texte*, pp. 416-17; BONOMI in *Transactions of the Royal Society of Literature*, 2 Ser. ii (1847), pl. facing p. 304 [middle and right], cf. pp. 299-304; BAGNOLD in *P.S.B.A.* x (1887-8), pls. after p. 452, cf. pp. 452-5, 456 [lower]-457 [upper]; BÉCHARD and PALMIERI, *L'Égypte et la Nubie* (1887), pl. liii (reversed); HOREAU, *Panorama d'Égypte et de Nubie* (1841), pl. ix [lower]; MASPERO, *Hist. anc.* ii, fig. on p. 423; id. *Essais*, figs. 52-3; id. *Eg. Art*, pl. facing p. 140; EBERS, *Ægypten*, i, fig. on p. 143; Eng. ed. fig. on p. 124; VIOLLET and DORESSE, *Egypt*, pls. 164-5; HOREAU MSS. 4 [2]; GRIFFITH INST. photo. 380A (SEBAH, 177A); LUMLEY MSS. 16; BURTON MSS. 25634, 27-32, and 25618, 89; WILKINSON MSS. v. 52 [bottom], xiii. 35 [lower left], xxxvii. 52 [lower], cf. 53. Upper part, LANGE and HIRMER, *Ægypten. Architektur* (1955), pl. 229; (1957), pl. 242; (1967), pl. 240. Head or face, CHAMPOLLION in *Bibl. Ég.* xxxi, pl. iii, pp. 98-101; RANKE, *The Art of Ancient Egypt*, and BREASTED, *Geschichte Ägyptens* (1936), 159; LANGE, *Äg. Kunst*, pl. 102; id. *Ägyptische Bildnisse*, Taf. 28; BAIKIE, *Eg. Antiq.* pl. iii [right]; HERMANN, *Führer durch die Altertümer von Memphis und Sakkara*, frontispiece; *The*

Egyptian Education Bureau London. The Bulletin, No. 46 (July 1950), front cover; MONTET, *Lives of the Pharaohs*, pl. on p. 147; ANGIOLETTI and BIGONGIARI, *Testimone in Egitto* (1969), Tav. 32; MACQUITTY, *Island of Isis*, fig. on p. 26. Belt, dagger, and pectoral, EVERS, *Staat aus dem Stein*, ii, Taf. i [33]; and texts, CHAMPOLLION, *Mon.* x [3]. Dagger and cartouche on belt, ROSELLINI, *Mon. Civ.* cxxii [3]. Texts, KITCHEN, *Ram. Inscr.* ii. 494 [191, A]. See HÉKÉKYAN BEY MSS. 37458, 32, 44-8 (with plans and views); id. *A Treatise on the Chronology of Sirodiac Monuments* (1863), pp. 17-19; HORNER in *Philosophical transactions of the Royal Society*, 148 (1858), pp. 55-7, 74, cf. 61-3.

Left fist of colossal statue, granite, probably from here, in Brit. Mus. 9. *Descr. Ant.* v, pls. 3, 4 [1]; BONOMI in *Transactions of the Royal Society of Literature*, 2 Ser. ii (1847), pl. facing p. 304 [bottom left]; LONG, *The Egyptian Antiquities in the British Museum*, i (1846), pp. 256-7 with fig. See SHARPE, *Eg. Antiq.* p. 57; *Guide (Sculpture)*, p. 164 [597].

Found near South Gate

Statues.

Royal.

Amenemhēt III, usurped by Merneptah, granite, in Berlin (East) Mus. 1121. BRUGSCH, *Recueil*, pl. ii; *Aeg. und Vorderasiat. Alterthümer*, Taf. 11; *Ausf. Verz.* Abb. 14, p. 80; WEIGALL, *Anc. Eg. . . . Art.* 98 [lower]; VON BISSING, *Denkmäler*, Text to Taf. 39 [a] [fig.]; FECHHEIMER, *Plastik*, Taf. 52-3; BÉNÉDITE in *Gazette des Beaux-Arts*, 5 Pér. i (1920), fig. on p. 315; STRÖMBOM, *Egyptens Konst.* fig. 43; MURRAY, *Sculpture*, pl. xviii [3]; SCHÄFER, *Äg. Kunst*, fig. on p. 25 [9]; *Führer* (1961), Abb. 19, p. 53; HORNEMANN, *Types*, i, pl. 169; WENIG in *Forschungen und Berichte. Staatliche Museen zu Berlin*, 3/4 (1961), Abb. 4, p. 122; Museul de artă, Bucharest. *Egiptul antic* [etc.] (1975), No. 81 with fig. on p. 36; DEMBSKA and ŁYCZKOWSKA in *Przegląd Orientalistyczny*, 4 [104] (1977), 1st pl. after p. 342. Upper part, HAMMERTON, *Universal History of the World*, i, fig. on p. 429; GARDINER MSS. photo. 28.3. Texts, *Aeg. Inscr.* i, p. 144, and ii, p. 18. Cartouches, WILKINSON MSS. xiii. 76 [top].

Rameses II holding standard with head of divinity, probably usurped by Rameses VI. WILKINSON MSS. v. 37 [middle right], xxxvii. 54, cf. 55. Text, *L. D. Text*, i, p. 204 [α]; BURTON MSS. 25618, 90; LIEDER squeezes, 16.8. See CHRISTOPHE in *Bull. Inst. Ég.* xxxvii [1] (1954-5), pp. 26-7 [7].

Rameses III. Name on back, LIEDER squeezes, 16.9. See BRUGSCH, *Reiseberichte*, p. 67.

Rameses IV seated, with cartouche of Rameses VI on bracelet. WILKINSON MSS. xiii. 31 (repr. CHRISTOPHE, op. cit. pl. vii, pp. 21-2 [3], 26 [3]).



Royal head, New Kingdom. WILKINSON MSS. xiii. 32 [upper left].

Shabataka seated, headless and fragmentary, granite, in Cairo Mus. CG 655. BORCHARDT, *Statuen*, iii, Bl. 121, p. 2; id. in *Ä.Z.* xxxvi (1898), Abb. 12, pp. 15-16 (as Karnak); VON BISSING, *Denkmäler*, Text to Taf. 60-1 [2nd fig.]; BOSSE, *Die menschliche Figur*, Taf. vii [142], p. 54; WILKINSON MSS. xiii. 37 [upper], 76 [bottom left]. Text, BRUGSCH, *Thes.* 1064 [7]; incomplete, MARIETTE, *Mon. div.* pl. 29 [e]. See MASPERO, *Guide*, p. 185 [680].

Private.

Minnakht (Theb. tb.87), lower part of seated statue, granite, temp. Tuthmosis III, in Vienna Mus. Inv. 5802. Text, VON BERGMANN, *Hieroglyphische Inschriften*, Taf. i [lower], ii [upper]; REINISCH, *Miramar*, Taf. iv [D], xxxiii, pp. 97 [9], 249-52 [1]; SETHE, *Urk.* iv. 1188-9 [351]; LIEDER squeezes, 16.4. See BRUGSCH, *Reiseberichte*, p. 71 [vii].

Seated headless statue of a Hereditary princess (*rprt*), granite, Dyn. XVIII, in Vienna Mus. Inv. 5769. Text, REINISCH, op. cit. Taf. xxx [C], p. 236 [23]. See BRUGSCH, op. cit. p. 71 [ix]; *Uebersicht* (1895), p. 36 [xxxvi]; (1923), p. 12 [xxxvi].

Amenmes(su) (Theb. tb. 373), son of Penzerti  and Iny  (i.e. Mutemōnet), scribe-statue, granite, temp. Ramesses II, upper part (headless) in Manchester Mus. 5187, lower part in Vienna Mus. Inv. 5749. Upper part, PETRIE, *Memphis*, iii, pls. xxx [2], xxxi [lower middle left], p. 39. Lower part, HABACHI in *Studies in Honor of George R. Hughes*, pp. 88–9 [6] with figs. 25–8, cf. 24 (upper part); REINISCH, *Miramar*, Taf. xxvii, pp. 225–8 [1]; BRUGSCH, *Monumens de l'Égypte* (1857), pl. xiii [lower]; list of feasts, id. *Thes.* 239–41; see id. *Reiseberichte*, p. 68 [i]; *Uebersicht* (1895), p. 34 [xvi]; (1923), p. 10 [xvi].

Kha'emwēset (son of Ramesses II), kneeling, incomplete, dedicated by son Ra'messu , granite, in Vienna Mus. Inv. 5768. Text, BRUGSCH, *Recueil*, pl. v [1, 2]; REINISCH, *Miramar*, Taf. xxx [A], pp. 233–5 [21]; WRESZINSKI, *Aegyptische Inschriften aus dem K. K. Hofmuseum in Wien*, pp. 132–5; GOMAA, *Chaemwese* [etc.], Abb. 17, p. 83 [48]; three columns, LIEDER squeezes, 16.2; titles, BRUGSCH, *Thes.* 957 [upper].



Nezem , Royal messenger to every country, Overseer of the granaries of the Western Border, etc., block-statue with figure of Ptaḥ-tatanen at front, sandstone, temp. Ramesses II, in Boston Mus. 29.730. DUNHAM in *J.E.A.* xxi (1935), pl. xix, pp. 150–1. Text on back, MARIETTE, *Mon. div.* pl. 27 [f]; BRUGSCH, *Recueil*, pl. v [3]; LIEDER squeezes, 16.6. See BRUGSCH, *Reiseberichte*, p. 71 [vi].

Paser, Vizier (Theb. tb. 106), temp. Sethos I to Ramesses II. (a) Kneeling with figure of Ptaḥ, cartouche of Ramesses II, granite, in Durham, Univ. Gulbenkian Mus. N.511; BIRCH, *Catalogue of the Collection of Egyptian Antiquities at Alnwick Castle*, pl. A [left], p. 72; *Gulbenkian Museum of Oriental Art and Archaeology*, pl. vii; RAWSON in *Apollo*, civ (1976), fig. 3 on p. 90; WILKINSON MSS. xxv. 51 verso; text, LIEDER squeezes, 16.1. (b) Standing holding figure of Ptaḥ, lower part, schist, in Cairo Mus. CG 630; BORCHARDT, *Statuen*, ii, Bl. 116, pp. 177–9; text, DARESSY in *Rec. Trav.* xiv (1893), pp. 172–4 [lxvii]; KITCHEN, *Ram. Inscr.* iii. 11–13 [5].

Upper part, head destroyed, with text on back pillar, temp. Ramesses II, in Cairo Mus. CG 870. BORCHARDT, *Statuen*, iii, p. 131 with fig. (as from the Serapeum at Ṣaqqâra); WILKINSON MSS. xviii. 42 [right] (provenance).



Ḥuy, kneeling, headless, holding Ḥaṭhor-head, Ramesside, in Cairo Mus. JE 71897. WILKINSON MSS. xiii. 77 [lower right].



Roma , Chief steward in the Temple of Ptaḥ, kneeling with naos of Ptaḥ, fragmentary, Ramesside, sandstone, in Berlin (East) Mus. 2085. Texts, *Aeg. Inscr.* ii, pp. 80–2; some, LIEDER squeezes, 16.5. See *Ausf. Verz.* pp. 140–1; BRUGSCH, *Reiseberichte*, pp. 69–70 [iii].

Ḥarwoz , Greatest of the seers of Heliopolis, etc., son of [Ḥa]r[ua] and Nekht-ubasterau , lower part of scribe-statue, granite, temp. Psammetikhos I, in Vienna Mus. Inv. 5750. REINISCH, *Miramar*, Taf. xxviii, pp. 228–9 [2]. Text, VON BERGMANN, *Hieroglyphische Inschriften* [etc.], Taf. iii [upper]. Names and titles, LIEBLEIN, *Dict.* No. 2380; LÉGRAIN in *Rec. Trav.* xxx (1908), pp. 20–1 [C]. See BRUGSCH, *Reiseberichte*, p. 70 [iv].

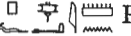
Uzaḥorresnet Neferebrēc-nebpeḥti, Commander of troops, with naos of Osiris, fragmentary, granite, temp. Psammetikhos II–Apries, in Vienna Mus. Inv. 5774 and Paris, Musée Rodin, 284. See id. ib. pp. 68–9 [ii]. Vienna Mus. Inv. 5774, see REINISCH, *Miramar*, p. 242 [29]. Paris, Musée Rodin, 284, see *Rodin collectionneur. Musée Rodin, Paris, 1967–1968*, No. 67.

Harsemtuemhēt , Prophet of Neith Mistress of Sais, etc., scribe-statue, upper part lost, sandstone, Dyn. XXVI, in Cairo Mus. CG 888. Text, BORCHARDT, *Statuen*, iii, pp. 139-40; DARESSY in *Mélanges Maspero*, i [1], pp. 86-8; on base, LIEDER squeezes, 16.7; WILKINSON MSS. xiii. 77 [upper]. See BRUGSCH, *Reiseberichte*, pp. 70-1 [v]. Another statue of same man, also probably from here, see *Bibl.* vii. 420 (as Harkhebi in error).

Pefteu'au-amūn  Psammethek-nūfer , Overseer of scribes of the council, etc., headless, kneeling with naos of Ptaḥ, diorite, Dyn. XXVI, in Turin Mus. Cat. 3020. HÉKÉKYAN BEY MSS. 37458, 49, 51, 52, 91 (provenance). Text, MASPERO in *Rec. Trav.* iv (1883), p. 150 [xliv]. Names and titles, BRUGSCH, *Thes.* 1431 [34]. See FABRETTI, etc., *R. Mus. di Torino*, pp. 409-10.

Iry , warb-priest of the Great Place of Ptaḥ, etc., son of Harenḥap , headless block-statue, sandstone, Late Period, in Cairo Mus. CG 1106. Text, BORCHARDT, *Statuen*, iv, pp. 59-60; MARIETTE, *Mon. div.* pl. 27 [c]; BRUGSCH, *Thes.* 1062 [1]; DE ROUGÉ, *Inscr. hiéro.* pl. ciii [upper]; LIEDER squeezes, 16.3. See BRUGSCH, *Reiseberichte*, p. 71 [viii].

Basalt head and torso (no name), Late Period, in Brussels, Mus. Roy. E.4064 and 4618 (1st ed. incorrect). PETRIE, *Memphis*, iii, pls. xxx [1], xxix [1], p. 39; text of E.4618, SPELEERS, *Rec. inscr.* p. 86 [325].

telae.

Fragment with text naming Osorkon II, in Cairo Mus. JE 28582. Text, WILKINSON MSS. xiii. 76 [middle].

Blocks.

Blocks of Amenophis IV, re-used, one (= pl. 2 of NICHOLSON) in Sydney Univ. Nicholson Mus. of Antiquities, R.1143. NICHOLSON, *On some Remains of the Disk Worshippers* [etc.] in *Transactions of the Royal Society of Literature*, 2 Ser. ix (1870), pls. 1, 2, pp. 197-214 (repr. NICHOLSON, *Aegyptiaca*, pls. 1, 2, pp. 117-34); some, WILKINSON MSS. xiii. 78 [lower]-79; WILBOUR MSS. 3C, 239; two, NEWBERRY in *J.E.A.* xiv (1928), figs. 3, 4 (from NICHOLSON), pp. 8-9. Texts of two, SANDMAN, *Texts from the Time of Akhenaten*, p. 200 [cclxxxiii, cclxxxiv]. Block in Sydney, LÖHR in *Studien zur altägyptischen Kultur*, 2 (1975), Taf. iv [1], pp. 154-5; see REEVE, *Catalogue of the Museum of Antiquities of the Sydney University* (1870), p. 91 [1143].

Column-drum, Ramesses II offering to Ptaḥ, granite, in Copenhagen, Ny Carlsberg Glypt. Æ.I.N. 1147; MOGENSEN, *Coll. ég.* pl. cx [A 741], p. 102; KOEFOED-PETERSEN, *Cat. des bas-reliefs*, pl. lxxxiii [79], p. 60. Another, in Manchester Mus. See PETRIE, *Memphis*, iii, p. 39.

Ptaḥ in shrine, Dyn. XIX, re-used, in Copenhagen, Ny Carlsberg Glypt. Æ.I.N. 1510. Id. ib. vi, pl. lix [39], p. 33; KOEFOED-PETERSEN, *Cat. des bas-reliefs*, pl. xlii [42], p. 38.

Block of Shabataka. Cartouche, WILKINSON MSS. xiii. 76 [near bottom].

Names of Achoris, WILKINSON MSS. xiii. 76 [bottom right].

Various.

Fragments of altar-pedestal of Ramesses II, usurped by Ramesses III, VII, and IX, granite. See BRUGSCH, *Reiseberichte*, p. 67 [bottom] (possibly this). (a) Formerly in Fernandez Colln., now in Marseilles, Mus. d'archéologie, 205; text, WILKINSON MSS. xiii. 64 [lower right], 68 [lower]; WILBOUR MSS. iii. D. 11 [middle]; see MASPERO, *Catalogue du Musée Égyptien de Marseille*, p. 5 [5]. (b) Formerly in Palin Colln., now in Louvre, D 61;

LEPSIUS, *Auswahl*, Taf. xiv [bottom]; see DE ROUGÉ, *Notice des monuments* (1883), pp. 210-11; VANDIER, *Guide* (1948), p. 22; (1952), p. 23.

SUBSIDIARY BUILDINGS AND MONUMENTS

A. CHAPEL OF AMENOPHIS III. Along east to west axis of Temple of Ptaḥ.

Two quartzite blocks, the King before Sekhmet, in Boston Mus. 10.650 and Copenhagen, Ny Carlsberg Glypt. Æ.I.N. 1152. PETRIE, *Memphis*, iii, pl. xxix [2, 3], p. 39. Boston block, SIMPSON, *The Face of Egypt: Permanence and Change in Egyptian Art*, No. 38 with fig. Copenhagen block, MOGENSEN, *Coll. ég.* pl. cvii [A 723], p. 99; id. in *B.I.F.A.O.* xxx (1930), pl. i [1], pp. 457-8; KOEFOED-PETERSEN, *Cat. des bas-reliefs*, pl. xlvi [35], p. 32; the King, MYŚLIWIEC, *Le Portrait royal dans le bas-relief du Nouvel Empire*, pl. lxiii [147].

Quartzite head of Amenophis III, uninscribed, allegedly from here, in New York, M.M.A. 56.138. SCOTT in *M.M.A. Bull.* n.s. xv (Feb. 1957), fig. on p. 148, cf. p. 149; MÜLLER (H. W.) in *Encyclopaedia of World Art*, iv, pl. 373.

B. CHAPEL OF AMASIS. Along east to west axis of Temple of Ptaḥ.

Quartzite blocks, including one, now in Edinburgh, Roy. Scot. Mus. 1910.154, with upper part of the King. PETRIE, *Memphis*, iii, pls. xxix [4, 5], xxxii [4-7], p. 39.

C. COLOSSUS OF RAMESSES II.

Colossal statue, with son Kha'emwëset and daughter Bent'anta in relief, usurped by Rameses IV, granite, now set up in Cairo, Station Square. CHRISTOPHE in *Bull. Inst. Ég.* xxxvii [1] (1954-5), pls. i-iv, figs. 1-3, pp. 5-19; HABACHI, *Features of the Deification of Rameses II*, pl. xiv, figs. 22 (= WILKINSON MSS. vii. 50), 23-4, pp. 35-7; WARD (J.), *Pyramids and Progress*, fig. on p. 47 [upper]; CAPART, *Memphis*, fig. 9; RICHER, *Le Nu*, fig. 100; PETRIE in WRIGHT (A.), *Twentieth Century Impressions of Egypt*, fig. 2 on p. 129 [lower]; LANGE, *Ägypten. Landschaft*, pl. 31; KUSCH, *Ägypten im Bild*, Abb. 58; DE MONTGON, *L'Égypte*, fig. on p. 89; WRIGHT (G. E.), *Biblical Archaeology*, fig. 31; *I.L.N.* Nov. 12, 1955, fig. on p. 823 [middle left]; DESROCHES-NOBLECOURT in *Bull. Soc. fr. d'Ég.* No. 23 (May 1957), pp. 15-18 with figs.; *Egypt Trav. Mag.* No. 17 (Dec. 1955), figs. on pp. 12-13; SOGA, *The Nile*, fig. on p. 142 [right]; MICHALOWSKI, *Art*, fig. 818; ELSTNER, *Egypt. The Gift of the Nile*, pl. 21; B. G. M[ERTZ] in *The New Encyclopaedia Britannica (Macropaedia)*, 15th ed., vol. 11, fig. on p. 896; GRIFFITH INST. photos. 380, 3287; SOMERS CLARKE MSS. 19.4 (photo.); WILKINSON MSS. vii. 50 and xiii. 34 [bottom]. Hand, FEDDEN, *The Land of Egypt*, fig. 8. Upper part of Bent'anta, BUTTLES, *The Queens of Egypt*, pl. xv; MURRAY, *Splendour*, pl. lxxvii [1]; id. *Sculpture*, pl. xxvii [2]; id. in *Anc. Eg.* (1925), pl. facing p. 97, cf. p. 102; head, PETRIE, *History*, iii, fig. 35; name, LIEBLEIN, *Dict.* No. 2098. Text, KITCHEN, *Ram. Inscr.* ii. 494 [191, B]. See BAGNOLD in *P.S.B.A.* x (1888), pp. 456 [upper], 457 [lower]-460; GOMAA, *Chaemwese* [etc.], p. 84 [50].

D. STELA OF APRIES.

Year 13, recording donation to Temple, sandstone. BRUGSCH, *Recueil*, pl. iii; MARIETTE, *Mon. div.* pl. 30 [b]; GUNN in *Ann. Serv.* xxvii (1927), pp. 211-37 with pl. Text, PIEHL in *A.Z.* xxviii (1890), p. 104; 1st line, WILKINSON MSS. xiii. 35 [top].

E. COLOSSAL ALABASTER SPHINX. Dyn. XVIII or Ramesses II.

Views¹ (some of details), ANTHES, *Mit Rahineh* 1956, pls. 54-5, pp. 42-3; MONTET, *Lives of the Pharaohs*, fig. on p. 69 (as Giza); DE MONTGON, *L'Égypte*, figs. on pp. 23, 31; ROBICHON and VARILLE, *En Égypte* (1937), pl. 31; (1955), pl. 30; LAURENT-TÄCKHOLM, *Faraos blomster*, pl. on p. 200; FEDDEN, *The Land of Egypt*, fig. 6; COTTRELL, *Egypt*, fig. 25; ROEDER, *Volks-glaube im Pharaonenreich*, Taf. 6; LANGE, *Ägypten. Landschaft*, pl. 32; id. *Äg. Kunst*, pl. 96; id. *Pyramiden, Sphinx, Pharaonen*, pl. 18; id. and HIRMER, *Ägypten. Architektur* (1955 and 1957), pl. 114; (1967), pl. 122; ELSTNER, *Egypt. The Gift of the Nile*, frontispiece; ANGIOLETTI and BIGONGIARI, *Testimone*, Tav. 31; KUSCH, *Ägypten im Bild*, Abb. 59; WOOD and DROWER, *Egypt in Colour*, pl. 18; VIOLLET and DORESSE, *Egypt*, pl. 163; DIMICK (M. T.), *Memphis. The City of the White Wall*, frontispiece; SIEGNER, *Ägypten. Ein Bildwerk*, pl. 148; GILBERT, *Couleurs de l'Égypte Ancienne*, pl. 14; WESTENDORF, *Das Alte Ägypten*, fig. on p. 166; SOGA, *The Nile*, figs. on pp. 145 [upper], 174 [left]-175; BINDER-HAGELSTANGE, *Ägypten. Ein Reiseführer* (1966), fig. on p. 321; *Capolavori*, i, No. 11 (1963), fig. on p. 169 [bottom]; Eng. ed. fig. on p. 161 [bottom]; DAVID, *The Egyptian Kingdoms*, figs. on pp. 9, 20; FAGAN, *The Rape of the Nile*, fig. on p. 343. See *Chron. d'Ég.* xxviii (1953), p. 282; EVERS, *Staat aus dem Stein*, ii, p. 85 [577].

F. HATHOR-COLUMN CAPITAL. Not *in situ*.

DIMICK (M. T.), *Memphis. The City of the White Wall*, 3rd pl. [lower].

G. EMBALMING HOUSE OF APIS-BULLS. Temp. Sesonchis I.

EL AMIR in *J.E.A.* 34 (1948), pp. 51-6, with views, etc., pls. xv-xvii; DIMICK (J.) in ANTHES, *Mit Rahineh* 1955, pp. 75-9, with plan, pl. 41, and views, etc., pls. 42-5; id. in *Archaeology*, 11 (1958), pp. 183-9, with reconstruction and view, figs. on pp. 183-4; see *J.E.A.* 27 (1941), p. 165. Position, cf. PETRIE, *Memphis*, i, pl. xxx [lower right], pp. 12-13. View, DIMICK (M. T.), *Memphis. The City of the White Wall*, 1st pl.

Embalming-tables with lion-bed in relief on sides, alabaster. (a) DIMICK (J.) in ANTHES, *Mit Rahineh* 1955, pl. 43 [a, 4], p. 77; id. in *Archaeology*, 11 (1958), on fig. on p. 186 [upper]; POSENER, SAUNERON, and YOYOTTE, *Dict. civ.* fig. on p. 169; *Great Museums*, fig. on p. 214 [60]; JAMES, *The Archaeology of Ancient Egypt*, fig. on p. 114; COTTRELL, *Egypt*, fig. 24; EL AMIR, op. cit. pl. xv [2-4, 6], pp. 51, 54; VIOLLET and DORESSE, *Egypt*, pls. 166-7; DESROCHES-NOBLECOURT, *Les Religions égyptiennes* in *L'Histoire générale des religions*, figs. on p. 309; DIMICK (M. T.), *Memphis. The City of the White Wall*, on 5th pl. (b) DIMICK (J.) in ANTHES, *Mit Rahineh* 1955, pl. 45 [a], p. 77 [5]; id. in *Archaeology*, 11 (1958), fig. on p. 186 [lower]; DIMICK (M. T.), *Memphis. The City of the White Wall*, 6th pl.; EL AMIR, op. cit. pls. xvi [3, 4], xvii [3], pp. 52, 55; ANTHES in *Penn. Mus. Bull.* 20 [1] (March 1956), fig. 8, pp. 21-3.

Altar of Necho II, alabaster. EL AMIR, op. cit. pl. xv [5], p. 51; DIMICK (J.) in ANTHES, *Mit Rahineh* 1955, pl. 45 [e], p. 78 [bottom].

Table of 3 blocks, (a) south side, cartouches of Sesonchis I, and Anubis libating and Shedsunefertem , Greatest of the Directors of craftsmen, son of 'Ankhefensekhmet, in Opening-the-Mouth ceremony, (b) north side, cartouches of Ramesses II and name of Apis. (a) BRUGSCH, *Thes.* 817, 948-9 [15]; DIMICK (J.) in *Archaeology*, 11 (1958), fig. on p. 188, cf. p. 189; id. in ANTHES, *Mit Rahineh* 1955, pl. 44 [a, 7], pp. 75, 78; DIMICK (M. T.),

¹ Selected references.

Memphis. The City of the White Wall, 4th pl.; text, BRUGSCH in *Ä.Z.* xvi (1878), pp. 38-41; part, VERCOUTTER, *Textes*, p. 57. See PETRIE, *Memphis*, i, pp. 12-13; KEES in *Ä.Z.* 87 (1962), pp. 145-6 [2].

Block-stand of Amasis, alabaster, in Cairo Mus. JE 86757. EL AMIR, op. cit. on pl. xvi [5], pp. 52, 54.

Other finds.

Lower part of seated statuette of Shedsunefertem, Greatest of the Directors of craftsmen, etc., quartzite, temp. Sesonchis I, in Cairo Mus. JE 86758. Text, KEES in *Ä.Z.* 87 (1962), pp. 142-5.

Front part of statuette of bull, diorite. EL AMIR, op. cit. pl. xvii [1], p. 52.

Stelae showing Apis-bull in shrine being conveyed in bark on wheels, Ptolemaic or Roman. (a) and (b) Id. ib. pl. xvii [4], p. 52; see KATER-SIBBES and VERMASEREN, *Apis, I*, p. 20 [67-8] (No. 68 not in Cambridge), cf. pl. xlviii (= No. 67, from EL-AMIR). (c) Cambridge, Fitzwilliam Mus. E.74.1911; PETRIE, *Memphis*, iv, pl. xxxi [bottom right], p. 24; KATER-SIBBES and VERMASEREN, op. cit. p. 20 [71] with pl. xlix (as No. 68 in error). (d) Cairo Mus. JE 45044; MARIETTE, *Mon. div.* pl. 35 [top]; *Encycl. phot. Caire*, pl. 192; see MASPERO, *Guide*, p. 472 [4495]; KATER-SIBBES and VERMASEREN, op. cit. p. 21 [72], cf. pl. li (from MARIETTE). (e) Berlin Mus. 7494, probably from here; ERMAN, *Die ägyptische Religion* (1905), fig. 107; (1909), fig. 106; id. *Die Religion der Ägypter* (1934), fig. 133; SCHARFF, *Götter Ägyptens*, Taf. 15; KATER-SIBBES and VERMASEREN, op. cit. p. 19 [66] with pl. xlvii; see *Ausf. Verz.* p. 313. (f) Leipzig, Äg. Mus. Inv.1830, probably from here; MOND and MYERS, *The Bucheum*, iii, pl. cix [1]; i, p. 80; HAAS, *Bilderatlas zur Religionsgeschichte*, fig. 47; KATER-SIBBES and VERMASEREN, op. cit. p. 20 [70] with pl. 1; F.E.R.E. photo. 5953; see KRAUSPE, *Ägyptisches Museum der Karl-Marx-Universität Leipzig* (1976), p. 63 [84/2]. (g) Hildesheim Mus. 1876, possibly from here; KATER-SIBBES and VERMASEREN, op. cit. p. 20 [69] with pl. 1; see IPPEL and ROEDER, *Die Denkmäler des Pelizaeus-Museums zu Hildesheim*, p. 89. (Others, see *supra*, p. 573, where the date is to be corrected, and Şaqqâra, Serapeum, Apis-stelae not assigned to a particular Apis-bull.)

Measuring-vessel of Darius I, year 34, alabaster, in Cairo Mus. JE 86754. EL AMIR, op. cit. pl. xvii [2], pp. 52, 54; LUCAS in *Ann. Serv.* xlii (1943), figs. 30-1, pp. 165-6.

H. CHAPEL OF SABACON.

Plan and view, PETRIE, *Memphis*, i, pls. xxvii [upper left], xxv [bottom left], p. 10.

I. TEMPLE OF TUTHMOSIS IV.

Foundation deposit, in Manchester Mus. 4938-46; PETRIE, *Memphis*, i, pl. xix [upper left], p. 8; texts, HELCK, *Urk.* iv. 1561 [498], cf. *Übersetz.* (1961), p. 151. Another, in Cairo Mus. JE 35174; see DARESSY in *Ann. Serv.* iii (1902), p. 25 [upper].

Found in this area.

Seated royal statues, Old Kingdom. Khephren, alabaster, in Cairo Mus. CG 41; Menkaurê, diorite, CG 42; Neuserre, granite, CG 38; Menkauhor, alabaster, CG 40; another, uninscribed, alabaster, CG 39. BORCHARDT, *Statuen*, i, Bl. 10, 11, pp. 36-9; VANDIER, *Manuel*, iii, pls. iii [2], v [2], vi [1, 3, 5], p. 558; MASPERO, *Guide*, figs. 12-14 (CG 42, 38-9), pp. 53-5 [111-15]; id. in GRÉBAUT, *Le Musée Égyptien*, i, pls. viii-xii, pp. 9-12; see BORCHARDT in *Ä.Z.* xxxvi (1898), p. 17. CG 38, BOTHMER in *Kémi*, xxi (1971), pl. ii, pp. 14-15; incomplete, id. in *Mitt. Kairo*, 30 (1974), Taf. 45 [a, b], p. 165 with note 3; PETRIE, *History*, i

(1899), fig. 45; (1923), fig. 58 (= PETRIE GĪZA photo. 515). CG 38-9, 41-2, MASPERO, *Hist. anc.* i, figs. on pp. 390, 364, 372, 374; BUDGE, *A History of Egypt*, ii, figs. on pp. 73, 44, 48, 53. CG 39, upper part, VON BISSING, *Äg. Kunstgeschichte*, Taf. li [343], *Text*, i, p. 86. CG 39, 42, GOSSE, *The Civilization of the Ancient Egyptians*, fig. 79. CG 40-1, HORNE-MANN, *Types*, iii, pls. 766, 686. CG 41, VON BISSING, *Denkmäler*, i, Taf. 9; WEIGALL, *Anc. Eg. . . . Art*, 28; SCHÄFER and ANDRAE, *Kunst* (1925), 220; (1930 and 1942), 230; RAGAI, *L'Art*, pl. 35 [62]; HAMMERTON, *Universal History of the World*, i, fig. on p. 425 [right]; *Encycl. phot. Caire*, pl. 11; PIJOÁN, *Summa Artis*, iii (1945), fig. 135; MONTET, *Eternal Egypt*, pl. 21; DONADONI, *Egyptian Museum Cairo*, pl. on p. 33 [left]; SUZUKI, *Sculpture of the World*, 3, *Egypt*, pl. 3; LECLANT and others, *Le temps des Pyramides*, fig. 183. CG 41-2, MASPERO, *Égypte*, figs. 143, 27. CG 42, id. *Eg. Art*, pl. facing p. 38 [upper]; id. *Essais*, fig. 1, pp. 20-2; incomplete, PETRIE GĪZA photo. 514.

Statue-base(?) imitating façade, alabaster, Dyn. II-III, in Cairo Mus. CG 57001 (JE 27851). MASPERO in GRÉBAUT, *Le Musée Égyptien*, i, pl. vii [lower], p. 9; BORCHARDT in *Ä.Z.* 41 (1904), Abb. 1, p. 85; LAUER, *Pyr. à deg.* i, fig. 69, pp. 87-8. See MASPERO, *Guide*, p. 79 [176].

Stela-fragment, double-scene, Amenophis III led by Sekhmet receives life from Ptaḥ, in Cairo Mus. JE 34558 (quoted in error in *Bibl.* ii². 446). Id. in GRÉBAUT, op. cit. pl. vii [upper], pp. 8-9. Heads of the King, MYŚLIWIEC, *Le Portrait royal dans le bas-relief du Nouvel Empire*, pls. lxxv [153], lxxvii [156]. See BOGOSLOVSKAYA in *Tutankhamon i ego vremya* (1976), p. 55, cf. fig. on p. 56.

J. CHAPEL OF SETHOS I.

HABACHI in ANTHES, *Mit Rahineh* 1956, p. 60.

Doorway, with lintel with double scene, a King before Ptaḥ. Id. in *Göttinger Miszellen*, No. 31 (1979), on pl. i on p. 55, cf. pp. 49-50.

Blocks of Sabacon and Taharqa, re-used (former in Berlin (West) Mus. 39/66). See LECLANT in *Orientalia*, n.s. 20 (1951), p. 346. Block of Sabacon, HABACHI in *Göttinger Miszellen*, No. 31 (1979), on pl. i on p. 55; KAISER, *Äg. Mus. Berlin* (1967), p. 96 [957] with Abb.

Three seated statues, Ptaḥ (headless) between Isis and Nephthys, both nursing Sethos I. PERKINS in *A.Ĵ.A.* liii (1949), pl. ix [A], p. 41; DESROCHES-NOBLECOURT in *Bull. Soc. fr. d'Ég.* No. 1 (June 1949), fig. on p. 10 [upper], cf. pp. 14, 17; LECLANT, op. cit. pls. xxxiii-xxxiv [16-18], pp. 345-6 [6]; Ptaḥ and Nephthys, *Jaarbericht Ex Oriente Lux*, No. 13 (1953-4), pl. lxxiii [upper], p. 304 [49].

Stela, Merneptah before Ptaḥ, with text mentioning building enclosure wall. HABACHI in ANTHES, *Mit Rahineh* 1955, pl. 9 [a], p. 5; text, KITCHEN, *Ram. Inscr.* iv. 32 [14].

K. TEMPLE OF RAMESSES II.

ANTHES, *Mit Rahineh* 1956, pp. 4-17, with plans, sections, and views, pls. 1-15; id. in *Penn. Mus. Bull.* 20 [1] (March 1956), pp. 12-14, with plan and views, on figs. 1, 2, 4; 21 [2] (June 1957), pp. 3-7, with plan and views, on figs. 1-3. Plan, id. *Mit Rahineh* 1955, on pl. 1.

Pylon.

HABACHI in ANTHES, *Mit Rahineh* 1956, pp. 60-5; JACQUET in *ib.* 1955, pl. 10 [b], pp. 13-14.

North wing. Texts, KITCHEN, *Ram. Inscr.* ii. 495-6 [192, B].

Outer face. Remains of [King] before goddess, offering milk, and before Ptaḥ below; HABACHI in *Mit Rahineh* 1956, pls. 20 [b], 21, 23 [b], fig. 4 [E 1, 3, 4, frag. 1], pp. 61, 64.

Thickness. King offers image of Ma'et to Ptaḥ, id. ib. pl. 20 [a], fig. 4 [S 1-6], pp. 61, 63.

Inner face. Two registers, King before god, and before Ptaḥ, with name of door below, and block with heads of Ptaḥ and King receiving *heb-sed*; id. ib. pls. 22, 23 [a], fig. 4 [W 1-5, frag. 3], pp. 63, 65.

Re-used block with bowing courtier, temp. Amenophis IV. Id. ib. pl. 23 [c, left], p. 65.

Sanctuary.

Views, ANTHES, *Mit Rahineh* 1955, pl. 10 [a], pp. 65-6; DIMICK (M. T.), *Memphis. The City of the White Wall*, 7th and 8th pls.; DESROCHES-NOBLECOURT, *Les Religions égyptiennes in L'Histoire générale des religions*, fig. on p. 249 [left]; BADAWI in *Ann. Serv.* xliv (1944), pls. xxiii, xxiv, p. 205.

King before Ptaḥ, on right side of façade, HELCK, *Ägypten* in HAUSSIG, *Götter und Mythen im Vorderen Orient*, Taf. v [10] after p. 406.

Re-used block of Amenophis III. See ANTHES, *Mit Rahineh* 1956, p. 5 [upper].



Names of Sethos II at base of walls and pillars. See id. ib. p. 8 [top].

Finds from Temple and neighbourhood

Statues.

Head, granite, probably Middle Kingdom. ANTHES, *Mit Rahineh* 1956, pl. 38 [a, b], p. 100 [40].

Head and shoulders of prostrate man, quartzite, probably end of Dyn. XVIII. Id. ib. pl. 38 [g, h], pp. 100-1 [42].

Amenhotp  Huy , Chief Governor in Memphis, Steward, middle part, sandstone, temp. Ramesses II. BADAWI in *Ann. Serv.* xliv (1944), pl. xxii, pp. 202-5.





Mutemwia  (woman), seated, lower part, Ramesside. ANTHES, *Mit Rahineh* 1956, pl. 35 [f, g], fig. 14 [a, b], p. 98 [37].

'Aḥmosi , seated, headless, New Kingdom. BAKRY in ib. 1955, pl. 22, fig. 13 [142], p. 41.

Roy , kneeling, lower part, New Kingdom. Id. ib. pl. 23, fig. 13 [143], p. 41.

Head, New Kingdom. ANTHES, *Mit Rahineh* 1956, pl. 35 [a-c], p. 100 [41].

Torso, quartzite, probably Dyn. XXVI. Id. ib. pl. 35 [d, e], fig. 14 [39], p. 100.

Uzahorresnet , Greatest of the physicians, temp. Amasis to Darius I, dedicated by Minardais(?) , son of Weḥebrēc  and Sems(et) , fragment, granite, probably Dyn. XXXI. Id. ib. pls. 36, 37 [a-c], fig. 13, pp. 98-100 [38]; see id. in *Penn. Mus. Bull.* 21 [2] (June 1957), p. 14.

Headless sphinx, probably Late Period. Id. *Mit Rahineh* 1956, pl. 40 [a], p. 101 [43].

Royal head, sculptor's model, Late Period or Ptolemaic. BAKRY in ib. 1955 pl. 24 [c, d], p. 41 [144].

Fragmentary statuettes of Tuēris, probably Dyn. XIX. ANTHES, *Mit Rahineh* 1956, pl. 27 [b-i], p. 78 [5-8].

Ramesside blocks. Mostly re-used in intrusive burials of 3rd Int. Period.

ANTHES, *Mit Rahineh* 1955, pp. 67-9, with position on pl. 1; id. ib. 1956, pp. 17-20, with position on pl. 1.

Jamb-fragment mentioning Inenay , Head of physicians in the Temple of Ptaḥ, and Paḥatiḥa , with former kneeling. BAKRY in *ib.* 1955, pl. 25 [d], fig. 13 [148], p. 43. Title of Inenay, VAN DE WALLE and DE MEULENAERE in *Rev. d'Ég.* 25 (1973), pp. 77-8.

Five blocks of Iyiry , Greatest of the Directors of craftsmen, temp. Sethos II (Šaqqâra tomb, see *supra*, p. 704). ANTHES, *Mit Rahineh* 1956, pls. 27 [a], 28, 29 [a], figs. 7, 8, pp. 79-85 [Ba]; id. in *Penn. Mus. Bull.* 21 [2] (June 1957), frontispiece, figs. 8-11, pp. 12-13, 28-33; deceased and wife, with children below, LECLANT in *Orientalia*, n.s. 27 (1958), pl. iii [4], p. 83.

Jambs of Neḥesi , Commander of the army of the Lord of the Two Lands, etc., with 3 columns of hymn to King's *ka* on each. ANTHES, *Mit Rahineh* 1956, pl. 29 [b, c], fig. 9, pp. 85-7 [Bb]; see id. in *Penn. Mus. Bull.* 21 [2] (June 1957), p. 13 [lower].

Five blocks, one of them originally of the end of Dyn. XVIII; id. *Mit Rahineh* 1956, pl. 30 [a-e], fig. 10, pp. 87-8 [Bc]; blocks with Osiris seated and man before Anubis, id. *ib.* 1955, pl. 12 [a], p. 67 note 11. Three blocks, including jamb-fragment of a Chief steward in the Temple of Ramesses II, id. *ib.* 1956, pl. 32 [a, d, c], fig. 11 [19, 21], pp. 88-9 [Bd]. Two blocks, lower part of seated man and of seated couple, id. *ib.* pl. 33 [b-d], p. 91 [Be].

Other blocks.



Fragment of text of Ḥaremḥab (less likely Amenophis I). ANTHES, *Mit Rahineh* 1956, pl. 39 [a, 57], fig. 14 [57], p. 104.

Fragment of topographical list, probably Dyn. XVIII. Id. *ib.* pl. 39 [a, 56], fig. 14 [56], p. 104.

Royal head, trial-piece, perhaps New Kingdom. Id. *ib.* 1955, pl. 24 [a], p. 43 [150].

Various fragments, id. *ib.* pls. 25 [a, c], 26 [a], pp. 43 [154, 152, 153].



Column-fragment of Ramesses II. PETRIE, *Memphis*, i, on pl. xxv [middle left], pp. 10, 12.

Lintel with Ptaḥ-khaḥ  and father 'Ashakhet , both God's fathers and Secretaries of the Temple of Ptaḥ, etc., kneeling before cartouches of Psusennes I, and jambs with offering-texts. ANTHES, *Mit Rahineh* 1956, pl. 31, fig. 12 [26-8], pp. 92-5 [Cb]; see id. in *Penn. Mus. Bull.* 21 [2] (June 1957), pp. 13-14 (as Kha).

Upper part of jamb with offering-text to Sekhmet, Dyn. XXI. Id. *Mit Rahineh* 1956, pl. 30 [f], fig. 12 [29], p. 96 [Cc].

Other finds.

Votive stela, man before Ptaḥ, and fragments of others, New Kingdom. ANTHES, *Mit Rahineh* 1956, pls. 39 [f, c-e], 40 [c], fig. 14 [53], pp. 102-4 [52, 51, 53-5].

Offering-basin with [statue] of Amenemḥēt , Scribe of the dockyard, son of Nebwaḥwi , Dyn. XIX. Id. *ib.* pls. 24, 25 [a-c], fig. 5, pp. 73-5; id. in *Penn. Mus. Bull.* 21 [2] (June 1957), fig. 5, pp. 5-7, 25; LECLANT in *Orientalia*, n.s. 27 (1958), pl. iv [5], p. 83; JACQUET and WALL-GORDON in *Mitt. Kairo*, 16 (1958), Taf. xii, xiii, pp. 161-75 with figs.; O'CONNOR and SILVERMAN in *Expedition*, 21 [2] (Winter 1979), fig. 49 on p. 32.

Faience tower-tile, inscribed on four faces, dedicated by Paḳebēḥ , Head of the making (*wḥt*) of faience (*mfkwt*), with offering-scene at top, Dyn. XIX. ANTHES, *Mit Rahineh* 1956, pl. 26 [a, b], fig. 6 [2], pp. 75-6.

Jar-fragment of Ḥatshepsut, alabaster. Id. *ib.* 1955, pl. 26 [d], fig. 14 [155], p. 44.

L. TEMPLE OF RAMESSES II.

EL-SAYED MAHMUD, *A New Temple for Hathor at Memphis*, p. 1 [top], with position on fig. 1.

pp. 32-40; discussion of parts, VIKENTIEV in *Bull. Inst. Ég.* xxx (1947-8), pp. 251-307 with figs. 6, 9; DRIOTON in *Ann. Serv.* xlv (1947), pp. 57-64, 99-106; GRDSELOFF in *ib.* pp. 107-20. See *Descr. somm.* No. 6301.

Sarcophagus-lid of woman Tatashakhet, Dyn. XXII. See EL-AMIR in *The Egyptian Education Bureau London. The Bulletin*, No. 40 (Nov.-Dec. 1949), p. 19.

THEKERTI , Great Chief of the Ma, Greatest of the Directors of craftsmen.¹ Probably temp. Sesonchis III.



Father, Sheshonk¹ (tomb, see above).

See BADAWI in *Ann. Serv.* liv (1957), p. 157 [bottom].

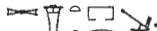
PEDĒSI , Great Chief of the Ma, Greatest of the Directors of craftsmen.¹ Temp. Pemu or later.

Parents,¹ Thekerti (tomb, see above) and Thesubasteper(t) .

See *id.* *ib.* xlv (1944), p. 181.

Outer sarcophagus of Amenhotp  Huy , Chief Governor in Memphis, etc., granite, temp. Ramesses II, re-used. *Id.* *ib.* pls. xvi-xx, pp. 182-202.

Anthropoid coffin, silver. *Id.* *ib.* pl. xxi, p. 185 note 1.

Another burial, probably from same or adjoining tomb.

Anthropoid sarcophagus of Amenhotp Huy (same as above), granite, re-used, in Cairo Mus. JE 59128. HAMADA in *ib.* xxxv (1935), pls. i, ii, pp. 122-31; HORNEMANN, *Types*, iii, pl. 799; see BADAWI, *op. cit.* xlv (1944), p. 182 note 1.

ĤARSIĒSI , Great Chief of the Ma, Greatest of the Directors of craftsmen.¹ Temp. Pemu or later.

Father, Thekerti (BADAWI) or Pedēsi (tombs of both, see above).

See BADAWI in *Ann. Serv.* xlv (1944), p. 181 note 2; liv (1957), pp. 157 [bottom]-158 [top].

FINDS FROM PTAḤ ENCLOSURE AND DEPENDENCIES

Statues.



Royal.

Sesostris II kneeling, fragment, sandstone, in Cairo Mus. CG 387. BORCHARDT, *Statuen*, ii, Bl. 61, pp. 6-7. Text, MARIETTE, *Mon. div.* pl. 27 [a]; BRUGSCH, *Thes.* 1063 [4].

Lower part of seated King, New Kingdom. PETRIE, *Memphis*, vi, pl. lvi [21], p. 33.

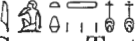
Private.

‘Ankhu , Scribe of the Great Prison, son of Itneferu  (mother), squatting, headless, granite, Middle Kingdom, in Cairo Mus. CG 410. Text, MARIETTE, *Mon. div.* pl. 27 [b]; BRUGSCH, *Thes.* 1062 [3]; BORCHARDT, *Statuen*, ii, p. 21.

Ptaḥwēr , Chief steward, etc., son of ‘Amet  (mother), granite, Middle

¹ Not mentioned in tomb.

Kingdom, in Berlin (East) Mus. 8808. Texts, *Aeg. Inschr.* i, p. 146; BRUGSCH, *Thes.* 1062 [2]; KAYSER, *Die Tempelstatuen ägyptischer Privatleute im mittleren und im neuen Reich*, pp. 14-15; on front, MARIETTE, op. cit. pl. 27 [d]. See *Ausf. Verz.* pp. 82-3.

Amenhotp, Chief [steward], etc. (Ṣaqqâra tomb, see *supra*, pp. 702-3), scribe-statue, granite, temp. Amenophis III, in Cairo Mus. CG 1169. Text, BORCHARDT, *Statuen*, iv, p. 88; HELCK, *Urk.* iv. 1801 [643], cf. *Übersetz.* (1961), p. 263.



Nefertemhotp, block-statue with four female relatives in high relief on sides, Ramesside, in Bristol Mus. H 395. PETRIE, *Memphis*, ii, pl. xviii [lower left], p. 14 (as Cambridge).

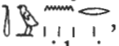

Ptaḥmosi, Royal scribe, Ramesside. Text, MARIETTE, *Mon. div.* pl. 28 [e].

Tenro , Scribe of the Temple of Ptaḥ, block-statue with naos at front, sandstone, Ramesside, in Cairo Mus. CG 1210. Text, id. ib. pl. 27 [h]; BORCHARDT, *Statuen*, iv, p. 109.

A Fan-bearer on the right of the King, Prophet of Amūn at Karnak, etc., Ramesside. Text, MARIETTE, op. cit. pl. 28 [a].

Papu , Overseer of cattle, Steward of Ptaḥ, etc., squatting, fragment, New Kingdom (?), in Cairo Mus. CG 671. See BORCHARDT, *Statuen*, iii, pp. 17-18 (text); text, MARIETTE, op. cit. pl. 28 [b].

Harsiēsi , Greatest of the Directors of craftsmen, etc., holding naos of Ḥathor, dedicated by son 'Ankhefensekhmet , same title, fragment, sandstone, temp. Sesonchis V, in Cairo Mus. CG 1212. BORCHARDT, *Statuen*, iv, Bl. 170, pp. 110-11. Text, MARIETTE, op. cit. pl. 27 [g].

Neferebrēc-sineit , Overseer of singers of the Great House, etc., son of Merib , kneeling with naos, lower part, schist, temp. Psammetikhos II or later, in Berlin (East) Mus. 8809. SCHÄFER and ANDRAE, *Kunst* (1925), 415 [1]; (1930), 431 [1]; (1942), 436 [1]; WORRINGER, *Ägyptische Kunst*, Abb. 29. Text, MARIETTE, op. cit. pl. 28 [d]; BRUGSCH, *Thes.* 1063 [6]; PIEHL in *P.S.B.A.* x (1888), pp. 536-7 [11], cf. xi (1889), p. 77. See *Ausf. Verz.* p. 256.

Pef[teu'aneit], Greatest of physicians of Upper and Lower Egypt, etc., middle part, basalt, temp. Apries. BAKRY in *Oriens Antiquus*, ix (1970), Tav. xxxv-xxxvii, fig. 1, pp. 325-33.

'Aksonb , First prophet of Amen-rēc Lord of Diospolis Inferior, etc., lower part of squatting statue, early Dyn. XXVI, in Cairo Mus. CG 915. Text, BORCHARDT, *Statuen*, iii, pp. 151-2; part, BRUGSCH, *Thes.* 1063 [5]; id. *Dictionnaire Géographique de l'Ancienne Égypte*, p. 1327 [top].

Head, sandstone, Dyn. XXV-XXVI, in Brit. Mus. 37883. PRISSE, *L'Art ég.* ii, *Sculpture*, 33rd pl. 'Fragments de statues iconiques' [etc.] [1], *Texte*, p. 409; BUDGE, *A History of Egypt*, iii, fig. on p. 131; WEIGALL, *Anc. Eg. . . . Art*, 320 [upper left]; HALL in *J.E.A.* xiii (1927), pls. xi, xii, pp. 27-9, 265-6; id. in HAMMERTON, *Universal History of the World*, ii, fig. on p. 1022 [left]; id. in *Encyclopaedia Britannica*, 14th ed. (1929), pl. x [9]; *The Cambridge Ancient History. Plates*, i (1927), pl. on p. 269 [a]; *Guide, 3rd and 4th*, fig. on p. 95, cf. p. 96 [186]; *Guide, 4th to 6th*, fig. on p. 123, cf. p. 124 [39]; *Guide, Eg. Collns.* (1930), fig. 92, p. 171; (1964), fig. 70, p. 185; ROSS, *The Art of Egypt*, pl. on p. 227; BOSSE, *Die menschliche Figur*, Taf. xi [201], p. 73; POULSEN (F.), *Ägyptens Kunst* (1933), fig. 81; WOLF, *Kunst*, Abb. 632; id. *Hochkulturen*, Abb. 55; WOLDERING, *Götter*, Abb. 96; VANDERSLEYEN, *Das Alte Ägypten*, Abb. 214; JAMES, *An Introduction to Ancient Egypt*, fig. 79.

Man (name lost) holding naos, fragment, slate, Dyn. XXVI, in Cairo Mus. CG 673. BORCHARDT, *Statuen*, iii, Bl. 123, p. 20. Text, MARIETTE, *Mon. div.* pl. 29 [c]; BRUGSCH, *Thes.* 1065 [9].

Head, granite, Late Period, in Copenhagen, Ny Carlsberg Glypt. Æ.I.N. 1505. PETRIE, *Memphis*, vi, pl. lv [15], p. 33; MOGENSEN, *Coll. ég.* pl. xviii [A 75], p. 20; KOEFOED-PETERSEN, *Cat. des statues*, pl. 122, p. 66 [114].

Divinities.

Upper part of bull-headed Apis, Dyn. XII. PETRIE, *Memphis*, vi, pl. liii [4], p. 32. See VANDIER, *Manuel*, iii, pp. 197 note 2, 605.

Osiris seated, headless, dedicated by Irtaḥor Neferebrēc-nūfer (Ṣaqqâra tb. LS 23), basalt, temp. Necho II to Apries, in Cairo Mus. CG 38236. DARESSY, *Statues*, pl. xiv, pp. 69-70. Text, MARIETTE, *Mon. div.* pl. 29 [a]; PIEHL in *Ä.Z.* xxv (1887), pp. 120-1 [xlv]. See MASPERO, *Guide*, p. 204 [828].

Lower part of statue of Osiris, dedicated by 'Ankhpekhrod  granite, Dyn. XXVI, in Cairo Mus. CG 38233. Text, MARIETTE, op. cit. pl. 28 [c]; DARESSY, op. cit. pp. 68, cf. 67 (as Ṣaqqâra).

Stelae.

Amenophis II before Ptaḥ, in Cairo Mus. CG 34020. LACAU, *Stèles*, pl. xii, pp. 40-1.



Tuthmosis IV smiting enemy before Ptaḥ. PETRIE, *Memphis*, vi, pl. lv [12], p. 33.

Amenḥotp, Steward, temp. Amenophis III (Ṣaqqâra tomb, see *supra*, pp. 702-3), and son Piay  Scribe, in Manchester Mus. 5050. Id. ib. ii, pls. xviii [lower right], xxv [lower left], pp. 14, 21. Text, HELCK, *Urk.* iv. 1804-6 [647], cf. *Übersetz.* (1961), pp. 264-5.

Wenent , son of Irterau (?), ear-stela, Dyn. XVIII(?). PETRIE, *Memphis*, vi, pl. lv [13], p. 33.

Ratmosi , Goldworker, with representation of Pylon of Temple of Ptaḥ, Dyn. XIX, in Cairo Mus. Temp. No. 16.3.25.12. MARIETTE, *Mon. div.* pl. 30 [a]; BRUYÈRE, *Mert Seger à Deir el Médineh*, fig. 30, p. 50 note 1. See YOYOTTE, *Les Pèlerinages dans l'Égypte ancienne* in *Sources Orientales*, iii, pp. 44, 70 [81] (as Temp. No. 14.3.25.12).

[Man] before Ptaḥ and Sekhmet, fragment, Dyn. XIX, in Copenhagen, Ny Carlsberg Glypt. Æ.I.N. 1516. PETRIE, *Memphis*, vi, pl. lviii [34], p. 33; MOGENSEN, *Coll. ég.* pl. cvi [A 717], p. 98; KOEFOED-PETERSEN, *Les Stèles égyptiennes*, pl. 38, pp. 32-3.

Unnūfer , God's father of Osiris, Scribe of accounts, etc., dedicated by son Shed-suḥori , Scribe of the temple, etc., fragment, Ramesside. Text, MARIETTE, *Mon. div.* pl. 29 [b].

. . . ḥotp before Reshef, Ramesside, in London, Univ. Coll. 14400. PETRIE, *Memphis*, iii, pl. xxxix [5], p. 39; LEBOVITCH in *Ann. Serv.* xl (1940), fig. 60, p. 491; STEWART, *Eg. Stelae*, i, pl. 35 [2], p. 44.

Hawk and ibis, Late Period or Ptolemaic, in Cairo Mus. PETRIE, *Memphis*, vi, pl. lx [44], p. 34.

Blocks.

Man with staff, Dyn. IV-V, re-used. PETRIE, *Memphis*, vi, pl. liii [3], p. 32.

Cornice of a Hereditary prince, etc., Old Kingdom(?). Id. ib. vi, pl. liv [5], p. 32.

Remains of texts, Old Kingdom. Id. ib. vi, pl. liii [1, 2], p. 32.

Column, probably temp. Amenophis III, in Brussels, Mus. Roy. E.4987. Id. ib. ii, pl. xix [upper left], pp. 14, 18; *Bruxelles. Mus. Roy. Département égyptien. Album* (1934), pl. 2. Text, SPELEERS, *Rec. inscr.* p. 38 [141].

Blocks of Amenophis IV. Fragment of rewarding scene, with collars, PETRIE, *op. cit.* vi, pl. liv [6], p. 32; see LÖHR in *Studien zur altägyptischen Kultur*, 2 (1975), Taf. v [2] (from PETRIE), p. 161. Fragment of boat scene, in Cambridge, Fitzwilliam Mus. E.19.1913, PETRIE, *op. cit.* vi, pl. liv [7], p. 32; detail showing animal skin, DAVIES MSS. 2.30 [middle]; see LÖHR, *op. cit.* Taf. iv [3] (from PETRIE), pp. 160-1. Offering-scene, in Brussels, Mus. Roy. E.7636, PETRIE, *op. cit.* vi, pl. liv [8], p. 32; LÖHR, *op. cit.* Taf. iv [2], p. 160. Upper part of Queen Nefertiti, in London, Univ. Coll. 73, PETRIE, *op. cit.* vi, pl. liv [9], p. 32; SAMSON, *Amarna*, pl. 21 (as 037); STEWART, *Eg. Stelae*, i, pl. 9 [2], p. 17; see LÖHR, *op. cit.* Taf. iii [2] (from PETRIE), p. 159 (as 037). Chariot and men before altars, formerly in von Bissing Colln. and The Hague, Scheurleer Mus., PETRIE, *op. cit.* vi, pl. liv [10], p. 32; COHEN, *Egypte en Voor-Azië*, pl. 14; see LÖHR, *op. cit.* Taf. v [1] (from PETRIE), pp. 159-60. All blocks, see ROEDER, *Amarna-Reliefs aus Hermopolis*, ii, pp. 362-3 [d].

Remains of text, temp. Amenophis IV, possibly in Cairo Mus. MARIETTE, *Mon. div.* pl. 27 [e]. Text, LEGRAIN, *Répertoire*, No. 298.

Block with cartouche of Ḥaremḥab, in Chicago, Or. Inst. 9169; PETRIE, *Memphis*, vi, pl. lv [17], p. 33. Another, *id. ib.* vi, pl. lv [16], p. 33.

Lintel of Ramesses II. *Id. ib.* vi, pl. lix [36], p. 33.

Jamb with two registers, Ramesses II offering image of Ma'et, and censuring and libating, before Ptaḥ, quartzite. *Id. ib.* vi, pl. lvi [18], p. 33.

Ramesses II before Ptaḥ. Sketches, WILBOUR MSS. 2 E, 19.

Head of King, perhaps Ramesses II, granite, in Copenhagen, Ny Carlsberg Glypt. Æ.I.N. 1513 (moved here from *Bibl.* iv. 86). PETRIE, *Memphis*, vi, pl. lix [37], p. 33; MOGENSEN, *Coll. ég.* pl. cix [A 738], p. 102 (as Ṭarkhân); KOEFOED-PETERSEN, *Cat. des bas-reliefs*, pl. xli [41], p. 38; head, MYŚLIWIEC, *Le Portrait royal dans le bas-relief du Nouvel Empire*, pl. cviii [239].

King, perhaps Ramesses II, embraced by Ptaḥ, granite. PETRIE, *op. cit.* vi, pl. lix [38], p. 33.

Part of double-scene, Kha'emwëset (son of Ramesses II) and men performing ceremony, in Cambridge, Fitzwilliam Mus. E.59.1914. *Id. ib.* vi, pl. lvi [22], p. 33; see GOMAA, *Chaemwese* [etc.], p. 82 [44].

Name of Merneptah-Siptah altered to Sethos II. PETRIE, *op. cit.* vi, pl. lvii [23], p. 33.

Lintel of Iny , Royal scribe, Chief lector-priest, Dyn. XIX, in Philadelphia Mus. E 12279. *Id. ib.* iii, pl. xxxi [bottom].

Column-fragments of Ramesses III. *Id. ib.* i, on pl. xxv [middle left], p. 10; ii, pl. xxiii [middle left, bottom left], pp. 14, 19.

Cornice of Ramesses VI, in Copenhagen, Ny Carlsberg Glypt. Æ.I.N. 1148. *Id. ib.* iii, pl. xxxi [lower middle right], pp. 39-40. See KOEFOED-PETERSEN, *Cat. des bas-reliefs*, p. 60 [80].

Upper part of King's *ka*, probably New Kingdom. PETRIE, *Memphis*, vi, pl. lviii [31], p. 33.

Two blocks, priests before King(?), and upper part of Ptaḥ, granite, probably New Kingdom. *Id. ib.* vi, pl. lviii [32-3], p. 33.

Apis-bull running towards Mert, basalt, probably New Kingdom. *Id. ib.* iii, pl. xxx [3], p. 39.

Remains of King Amenemōpet before Sekhmet, in Cairo Mus. Temp. No. 3.7.24.11. Texts, GAUTHIER in *Ann. Serv.* xxii (1922), pp. 204-5.

Column of Shedsunefertem , Chief Governor of Memphis, etc., with cartouches of Siamūn, and Ptaḥ and Ḥathor. PETRIE, *Memphis*, ii, pl. xxiii [right], p. 14.

Cornice-fragment of Sesonchis I. Id. ib. vi, pl. lvii [24], p. 33.

[King] before bark of Sokari, sandstone, Dyn. XXVI, about 30 metres south-east of Pylon of the Temple of Ptah. Text, DARESSY in *Ann. Serv.* iii (1902), p. 31 [19].

Trial-piece, hawk, quartzite, Dyn. XXVI, in Copenhagen, Ny Carlsberg Glypt. Æ.I.N. 1512. PETRIE, *Memphis*, vi, pl. lxi [50], p. 34; MOGENSEN, *Coll. ég.* pl. lxxxv [A 647], p. 82; id. *Modeller og Øvelsesstykker* [etc.] in *Fra Ny Carlsberg Glyptoteks Samlinger* (1920), fig. 30, p. 36.

Cartouche of Nektanebos I, in London, Univ. Coll. 14538; PETRIE, *Memphis*, vi, pl. lvii [25], p. 33. Another, id. ib. iii, pl. xxxii [1].

Blocks of Nektanebos II, re-used in tank or vat between Hypostyle Hall of the Temple of Ptah and Embalming House of Apis-bulls. Texts, DARESSY in *Ann. Serv.* ii (1901), pp. 241-2.

Two inscribed blocks, Late Period. BRUGSCH, *Thes.* 1061 [bottom].

Three Souls of Pe, Late Period, in Copenhagen, Ny Carlsberg Glypt. Æ.I.N. 1511. PETRIE, *Memphis*, vi, pl. lv [11], p. 32; MOGENSEN, *Coll. ég.* pl. cviii [A 733], p. 101; KOEFOED-PETERSEN, *Cat. des bas-reliefs*, pl. li [51], pp. 42-3.

Trial-piece, vulture, Late Period, in London, Univ. Coll. 15507. PETRIE, op. cit. v, pl. lxxviii [bottom left], p. 33; VON BISSING in *Bull. Antieke Beschaving*, v [1] (June 1930), fig. 3 on pl. facing p. 6 (as Cairo).

Various.

Sarcophagus of cat, dedicated by Dḥutmosi (son of Amenophis III), in Cairo Mus. CG 5003. BORCHARDT in *Ä.Z.* 44 (1907), p. 97 with fig.; WILDUNG in *Die Kunst*, 90 [6] (June 1978), fig. 5 on p. 335; id. and GRIMM, *Götter, Pharaonen* (1978), No. 28; FISCHER in *Metropolitan Museum Journal*, 12 (1977), fig. 5, p. 178 with note 33. Texts, DARESSY in *Rec. Trav.* xiv (1893), pp. 174-5 [lxix]; REISNER, *Canopics*, pp. 392-4. See MASPERO, *Guide* (1902), p. 75 [232].

Kôm el-Nawa

Lintel-fragments of Amenemḥet II, granite. L. D. *Text*, i, p. 203 [middle]; PETRIE, *Memphis*, ii, pl. xxiii [top], p. 14.

Block of Amasis, granite. Id. ib. ii, pl. xxiii [left lower middle], p. 14.

Block with head of Ptah, quartzite, Dyn. XVIII. *Sotheby Sale Cat.* Nov. 11, 1963, No. 89 with fig.

Lower part of Horus on crocodiles stela, granite, Dyn. XXVI, in Cairo Mus. CG 9411. Text, DARESSY, *Textes et dessins magiques (Cat. Caire)*, pp. 26-7; part, KLASSENS, *A Magical Statue Base* [etc.], pp. 37-8 [C 4].

Kôm el-Arbaîn

Fragments of statue-base of Ḥori , Governor of the town, Vizier, etc., son of Ḥori, Greatest of the Directors of craftsmen, sandstone, temp. Merneptah-Siptah to Ramesses III, one formerly in New York Hist. Soc. Colln., now in Brooklyn Mus. 37.1920E, other in Cairo Mus. CG 1174. Brooklyn Mus. fragment, DE MEULENAERE in *Annuaire de l'Institut de Philologie et d'Histoire Orientales et Slaves*, xx (1968-72), pls. i, ii, pp. 191-6; ČERNÝ MSS. photos. 2.186; see *N.Y.H.S. Cat.* p. 8 [126]. Text of Cairo fragment, BORCHARDT, *Statuen*, iv, p. 90.

Remains of double-stature, lower part of seated god probably crowning kneeling Haremhab (only feet left), quartzite. See SIMPSON in *J.E.A.* 42 (1956), pp. 118-19.

Kôm el-Fakhry

CEMETERY. 1st Int. Period or early Middle Kingdom.

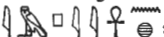
Tombs with decorated burial chambers, see EL HITTA in *La Revue du Caire*, xxxiii [175] (1955), pp. 50-1; LILYQUIST in *J.A.R.C.E.* xi (1974), pp. 27-30 (several men called Impy and woman Impyankh , Prophetess of Hathor, etc.), with views, etc., pls. i-iii.

Re-used blocks from tombs of Dynasty XXX.

Neferseshem-psammethek , Scribe of divine books, etc., in Cairo Mus. See YOYOTTE in *Chron. d'Ég.* xxix (1954), p. 278. (a) Presentation of jewellery, with deceased seated on left, JE 10978; MARIETTE, *Mon. div.* pl. 35 [middle]; MASPERO, *Le Musée Égyptien*, ii, pls. xxxv [upper], xxxvi, pp. 79-80; id. *Égypte*, fig. 520; id. *Guide* (1914), fig. 61, p. 203 [870]; (1915), fig. 73, p. 210 [870]; BORCHARDT, *Das Grabdenkmal des Königs S'ashu-er*, ii, Abb. 10, p. 63; SCHMIDT, *Levende og Døde*, fig. 892; TERRACE and FISCHER, *Treasures*, pp. 173-6 with pls.; DEVÉRIA squeezes, 6165, i. 51; couples with jewellery, *Encycl. phot. Caire*, pl. 191; Brussels. 5000 ans, fig. 44, p. 30 [72]; London. 5000 Years, pl. xxiii, p. 21 [78]; Louisiana. 5000 års, No. 204 with fig.; Zürich. 5000 Jahre, Abb. 70, p. 76 [215]; head of 2nd girl from right, HEMELRIJK in *Bull. Antieke Beschaving*, xxxviii (1963), fig. 1, pp. 31-2; 1st and 2nd couples from right, DRIOTON in *Studies Presented to F. Ll. Griffith*, pl. 46 [c], pp. 293-4; 2nd, ALDRED, *Jewels of the Pharaohs*, pl. 149; 2nd and 3rd, WEIGALL, *Anc. Eg. . . . Art*, 324; see MARIETTE, *Notice des principaux monuments . . . à Boulaq* (1864), pp. 75-6 [49]. (b) Offering-bringers before deceased seated on left, JE 10976; MARIETTE, *Mon. div.* pl. 35 [bottom]; MASPERO, *Le Musée Égyptien*, ii, pls. xxxii [top], xxxiii; PERROT and CHIPIEZ, *Hist. de l'Art*, i, figs. 485-6; SPRINGER, *Die Kunst des Altertums* (1923), Abb. 128; BUHL in *Fra Nationalmuseets Arbejdsmark* (1948), fig. 2, pp. 49-50; 1st to 4th offering-bringers with children, *Encycl. phot. Caire*, pl. 189; 4th to 6th, HAMANN, *Ag. Kunst*, Abb. 326; see MASPERO, *Guide*, p. 200 [801].

Upper parts of offering-bringers before deceased seated on right, JE 10977. MASPERO, *Le Musée Égyptien*, ii, pl. xxxviii [top], pp. 81-2.

Miscellaneous.

Bust, perhaps Tutankhamûn or Haremhab, in Cairo Mus. JE 55032. See *Descr. somm.* No. 6183.

Lower part of statue of King Petubastis (Sehetepibrê) seated, granite. HABACHI in *Å.Z.* 93 (1966), Taf. v [b, c], figs. 1-3, pp. 70-1.

Fragment of statue of kneeling captive attacked by lion, slate, Late Period, in Cairo Mus. Temp. No. 16.9.30.12. HORNEMANN, *Types*, v, pl. 1333.

Kôm el-Rabîca

TEMPLE OF HATHOR. Temp. Ramesses II.

EL-SAYED MAHMUD, *A New Temple for Hathor at Memphis*, passim, with plan, fig. 2, diagrams of scenes, fig. 3, and views, pls. 1-4, 6. View, BAKRY in *Mitt. Kairo*, 28 (1972),

Taf. xxii [left upper], p. 77. Names of Ḥathor, KITCHEN, *Ram. Inscr.* ii. 496 [192, C]. See LECLANT in *Orientalia*, n.s. 41 (1972), p. 254 [13]; 42 (1973), p. 403 [25, b].

Pylon.

Doorway, west thickness. Remains of top register, with King before [a god], scene with [Ptaḥ], and royal names.

EL-SAYED MAHMUD, *op. cit.* pls. i and 5, p. 7 (references to pls. in text incorrect, *passim*).

West part, inner face. From east, remains of top two registers, I, 1, King offering incense to Ptaḥ, 2, before a seated god, 3, kneeling on *heb*-sign before a seated god, with a goddess behind him. II, 1, King before a lioness-headed goddess, 2, preceded by standards, 3, purified by Horus and Thoth before Ptaḥ, 4, offering collar to Ḥathor.

Id. *ib.* pls. ii-x and 11, 12, 15, 16, pp. 7-8. 4, BAKRY, *op. cit.* Taf. xxii [left lower], p. 77.

Court.

West wall. Remains of register II (I lost), from north, 1, King in foundation ceremony before Sefkhet-ṭabu, 2, before Min-Amūn, 3, with *hes*-vase before Ḥathor Mistress of Ḥetept, 4, before [a god], 5, [before a lion-headed goddess].

EL-SAYED MAHMUD, *op. cit.* pls. xi-xix and 13, 14, pp. 8-11.





Pillars with Ḥathor capitals and scenes of king before gods (including Amen-rē^c) and royal names.

Id. *ib.* pls. 7-10, p. 11, with texts of one column on fig. 4; BAKRY, *op. cit.* Taf. xxii [right], p. 77.

BUILDING OF SIAMŪN.

Plan, PETRIE, *Memphis*, i, pl. xxx [upper right], p. 12.

Monuments of 'Ankhefenmut.

Lintel, Siamūn in double-scene, right, followed by 'Ankhefenmut , God's father, Secretary of Ptaḥ, etc., son of Ḥatiay , before Ptaḥ and Sekhmet, left, followed by Neterkheperre^c-mer(y)ptaḥ , Paupau , Greatest of the Directors of craftsmen of Ptaḥ, etc., before Ptaḥ and Ḥathor, and left jamb with offering-texts of 'Ankhefenmut, in Copenhagen, Ny Carlsberg Glypt. Æ.I.N. 1012. Id. *ib.* ii, pl. xxiv [top and right], pp. 14-15, 19-20; MOGENSEN, *Coll. ég.* pl. cxi [A 746], pp. 102-3; SCHMIDT, *Choix* (1910), pls. xvii [43], xviii [45], pp. 31-2; id. *Levende og Døde*, figs. 484-5; KOEFOED-PETERSEN, *Cat. des bas-reliefs*, pls. lxvii-lxxii, pp. 54-5 [71], 74-5. Texts, id. *Rec. inscr.* pp. 84-5. Names and titles, see DE MEULENAERE in *Bibliotheca Orientalis*, xiv (1957), p. 72 [71].

Lintels, double-scene, 'Ankhefenmut as fan-bearer kneeling before names of Siamūn. (a) Philadelphia Mus. E 14345; PETRIE, *Memphis*, ii, pl. xxiv [upper middle], pp. 15, 20; RANKE in *Penn. Mus. Bull.* xv [2-3] (Nov. 1950), fig. 26, p. 46. (b) Manchester Mus. 4933; texts, PETRIE, *op. cit.* ii, pl. xxiv [left lower middle]. (c) Pittsburgh, Museum of Art, Carnegie Institute, 3755; texts, id. *ib.* ii, pl. xxiv [right lower middle]. (d) Brit. Mus. 1470; texts, id. *ib.* ii, pl. xxiv [left bottom]; see *Guide (Sculpture)*, pp. 303-4 [1170] (with royal names).

Fragments of lintel and jamb, similar to last (name lost), re-used near Enclosure Wall of Ptaḥ. ANTHES, *Mit Rahineh 1956*, pls. 32 [b], 33 [a], fig. 11 [24-5], p. 92.

Lintel, Siamūn followed by 'Ankhefenmut before Amen-rē^c and Mut, in Cairo Mus. JE 40033. PETRIE, *Memphis*, i, pl. xxxi [top and middle right], p. 13; ii, pl. xix [left bottom]

(omitting 'Ankhefenmut), p. 18; upper part of Siamûn, id. *Egypt and Israel*, fig. 32; see MASPERO, *Guide* (1915), p. 181 [663].

Two jamb-fragments of 'Ankhefenmut (another name of father was Kha'emwëset , in Bristol, City Mus. H 3568-9. See GRINSELL, *Guide Catalogue to the Collections from Ancient Egypt* (1972), p. 57. Texts of one, PETRIE, *Memphis*, ii, pl. xxiv [middle bottom], pp. 15, 20.

Two jamb-fragments of 'Ankhefenmut, in Brussels, Mus. Roy. E.4979, and Manchester Mus. 5106. Id. ib. ii, pl. xxiii [middle and right of middle lower], pp. 14, 19. Text of Brussels E.4979, SPELEERS, *Rec. inscr.* p. 81 [308].

Other finds.

Fragmentary lintel, left part of double-scene, [Osorkon I] followed by Zeptahefankh, Overseer of cattle of the Temple of Ptaḥ, etc., before Bubastis and Horus, in Munich, Staatl. Samml. Gl.78. VON BISSING in *Münchener Jahrb.* (1911), Abb. 11, p. 166 [12]; *Äg. Sammlung* (1966), Abb. 64; *Staatl. Sammlung* (1972), pl. 45 [lower], p. 82; EGGBRECHT *Schlachtungsbriäuche im Alten Ägypten* [etc.], Taf. xiv [C]. See PETRIE, *Memphis*, ii, p. 14; WOLTERS, *Illus. Kat.* p. 13 [34c]; id. *Führer*, p. 13 [70]; *Staatl. Sammlung* (1976), p. 147.

Two fragments of texts mentioning Temple of Osiris, probably 3rd Int. Period, re-used. PETRIE, *Memphis*, i, pl. xxxii [left], p. 13.

Block with remains of biographical text, 3rd Int. Period. Id. ib. ii, pl. xxiii [upper middle], pp. 14, 19.

Statue (head and feet lost) of Thaihepimu , brother of Teos and father of Nektanebos II, breccia, in New York, M.M.A. 08.205.1. Id. ib. i, pls. xxxi [upper left], xxxii [right], pp. 13, 20-1; SCOTT, *Egyptian Statues* (1945), 28th pl. (as quartzite); *Guide to the Collections. Egyptian Art* (1962), fig. 49. See *A Handbook of the Egyptian Rooms* (1911), pp. 133-4; DE MEULENAERE in *Ä.Z.* 90 (1963), p. 91.

Ramesseid temple-blocks. From foundations of church south-west of Building of Siamûn.

PETRIE, *Memphis*, iv, pls. xxvii-xxx, pp. 23-4. Libyan(?) figures and cartouches of Ramesses II (= pl. xxviii [top right]) and offerings (= pl. xxix [4th from top right]), in Cambridge, Fitzwilliam Mus. E.63 and 75.1911. Parts of 4 hieroglyphs from name of Ramesses II (= pl. xxviii [on top left]), in Chicago, Or. Inst. 9160. Arm with censer, and smaller figure of man below (= pl. xxix [middle bottom]), in Copenhagen, Ny Carlsberg Glypt. Æ.I.N. 1421; MOGENSEN, *Coll. ég.* pl. c [A 693], pp. 93-4; KOEFOED-PETERSEN, *Cat. des bas-reliefs*, pl. xlvi [49], p. 42. Names of Ramesses II (= pl. xxviii [top left]), in Evans-ton (Ill.), Hibbard Memorial Library, 4. Palimpsest texts (= pl. xxx [2nd from top right]), in Manchester Mus. 5375.

Kôm el-Qalra

Map LXXII [1]

ANTHES, *Mit Rahineh* 1956, pp. 35-8, with plan, figs. 2, cf. 1.

TEMPLE OF PTAḤ. Merneptah.

PETRIE, *Memphis*, i, pp. 3-4, 11-12, with plan, pl. xxvii.

Outer court.

Doorway. Lintel, double-scene. King seated in kiosk, and smiting foes before Ptaḥ;

QUIBELL in *Ann. Serv.* viii (1907), pp. 120–1 with pl.; PETRIE, *Memphis*, ii, pl. xxi, pp. 18–19.

Re-used lotus-capitals, probably Dyn. V. One, in Manchester Mus. 5107, id. ib. i, pl. iii [right top], p. 6; PETRIE, *Egyptian Architecture*, pl. xviii [94]; SPANTON in *Anc. Eg.* (1917), fig. 47, p. 19. Another two, in Manchester Mus. 5102 and Cairo Mus.; one, PETRIE, *Memphis*, ii, pl. xviii [upper right], pp. 13–14; SPANTON, op. cit. fig. 46, p. 19.

Re-used column-fragment of Kha'emwëset (son of Ramesses II), in Edinburgh, Roy. Scot. Mus. 1908.364; PETRIE, *Memphis*, i, pl. xxv [top left], pp. 10, 11; GOSSE, *The Civilization of the Ancient Egyptians*, fig. 107; GOMAA, *Chaemwese* [etc.], Abb. 15, p. 82 [42]. Text of another, presumably from here, PETRIE, *Memphis*, ii, pl. xxv [upper left], pp. 15, 20; see GOMAA, op. cit. p. 82 [43], cf. Abb. 16 [b] (from PETRIE).

Inscribed column with rope-pattern binding, probably from here; PETRIE, *Memphis*, i, pls. xxv [upper right], xxvi [6], pp. 10, 20.

Inner doorway.

Left jamb with names of the King and Nile-gods at bottom, in Brit. Mus. 1469; id. ib. i, pl. xxix [right], p. 11; see *Guide (Sculpture)*, p. 303 [1169].

Finds

Two colossal negro heads, Dyn. XIX, in Bristol, City Mus. H 799, and Copenhagen, Ny Carlsberg Glypt. Æ.I.N. 1047. PETRIE, *Memphis*, ii, pl. xx [top and middle], p. 14. Bristol H 799, GRINSELL, *Guide Catalogue to the Collections from Ancient Egypt* (1972), fig. 29, p. 52. Copenhagen Æ.I.N. 1047, MOGENSEN, *Coll. ég.* pl. xviii [A 76], p. 20; KOEFOED-PETERSEN, *Cat. des statues*, pl. 92, p. 50 [80].

Stela-fragment with head of Sëth, Ramesside. PETRIE, op. cit. ii, pl. xx [bottom], p. 14.

Two stelae with Hathor-cow, one dedicated by woman Tanenuny  Nurse of the King's son, Ramesside, in Manchester Mus. 4910, 4914. Id. ib. i, pl. xxviii [21–2], p. 12.

PYLON. Merneptah.

C. S. F[ISHER] in *Penn. Mus. Journ.* viii (1917), pp. 226–8. View, ib. vi (1915), fig. 61 on p. 81.

Two papyrus-columns, King before gods, in Philadelphia Mus. E 13576–7. *Penn. Mus. Journ.* xvii (1926), fig. on p. 111 [left, right]; RANKE in *Penn. Mus. Bull.* xv [2–3] (Nov. 1950), on fig. 63, p. 104; part of text, FISCHER in *Metropolitan Museum Journal*, 12 (1977), p. 177.

Outer doorway, in Philadelphia Mus. E 13575, and two blocks E 13568–9. (a) and (b) Jambs. Four registers, **I**, King before Ptah, **II**, receives *heb-sed* from Ptah in kiosk, **III**, receives  from Nefertem, **IV**, smites foes. Base, *sma*-symbol bound by Nile-gods, with two kneeling captives, and names of Ramesses IV below. (c) and (d) Thicknesses. Ptah in kiosk before names of the King. Base, four geographical personifications, and names of Ramesses IV below.

(a) and (b) Omitting **I**, *Penn. Mus. Journ.* xvii (1926), fig. on p. 109 [left, right]. (a) **IV** and base, RANKE in *Penn. Mus. Bull.* xv [2–3] (Nov. 1950), fig. 62, pp. 102–4; Nile-gods, CAPART in *Chron. d'Ég.* xxxii (1957), fig. 78, p. 235 (repr. as *Causeries sur l'Art égyptien*, fig. 68, p. 77). (b) Two blocks E 13568–9, see RANKE, op. cit. p. 105 [near top]. **II**, C. S. F[ISHER] in *Penn. Mus. Journ.* viii (1917), fig. 84, p. 226; **IV** and base, CHRISTOPHE in *Bull. Inst. Ég.* xxxvii [1] (1954–5), pl. vi, p. 21 [2, b]. (d) Bottom register and base, id. ib. pl. v, pp. 20–1 [2, a]; base, ANTHES, *Mit Rahineh* 1956, pl. 53, pp. 14, 36–7, 38.

PALACE. Merneptah.

Plan LXXII [2]

C. S. F[ISHER] in *Penn. Mus. Journ.* viii (1917), pp. 211-25, with plan, fig. 79, and views, figs. 77-8, 80-1, 83. View, *ib.* vi (1915), fig. 60 on p. 81. Reconstruction, O'CONNOR and SILVERMAN in *Expedition*, 21 [2] (Winter 1979), fig. 36 on p. 25 (by Fisher).

Outer Vestibule. 20 of Fisher.

Columns and bases of Merneptah, in Philadelphia Mus. E 13558-9. E 13558B, *Penn. Mus. Journ.* xvii (1926), fig. on p. 107 [left].

Court. 19 of Fisher.

(1) Lintel, in Philadelphia Mus. E 13557.

Inner Vestibule. 18 of Fisher.

Column of Ramesses II, re-used by Merneptah, granite, in Philadelphia Mus. E 636. RANKE in *Penn. Mus. Bull.* xv [2-3] (Nov. 1950), on fig. 59, p. 100; O'CONNOR and SILVERMAN in *Expedition*, 21 [2] (Winter 1979), on fig. 64 on p. 42.

Throne Room. 7 of Fisher.

C. S. F[ISHER] in *Penn. Mus. Journ.* xii (1921), pp. 30-4 with pl. iii (reconstruction); xv (1924), pp. 93-100. Model, *ib.* xvii (1926), fig. on p. 113.

(2) Doorway. Lintel, double-scene, King seated receiving *heb-sed* from Horus and Sēth standards, and before Ptaḥ, jamb, names with Nile-gods at bottom.

FISHER in *ib.* xv (1924), fig. on p. 92, cf. pp. 97-8; PHILAD. photos. 33989-91.

Dais of throne, bows and foreigners. C. S. F[ISHER] in *Penn. Mus. Journ.* viii (1917), fig. 82, p. 218; KUHLMANN, *Der Thron im alten Ägypten*, Taf. v [12].

Window, in Philadelphia Mus. E 13565. FISHER in *Penn. Mus. Journ.* xv (1924), fig. on p. 96, cf. p. 97; see RANKE in *Penn. Mus. Bull.* xv [2-3] (Nov. 1950), pp. 104-5.

Room 14 (of Fisher).

(3) Doorway. Block from outer left jamb with remains of text and King with lion smiting foreigners, in Philadelphia Mus. E 17527.

Philadelphia E 17527, ΠΙΘΟΑΝ, *Summa Artis*, iii (1945), fig. 554; see RANKE in *Penn. Mus. Bull.* xv [2-3] (Nov. 1950), p. 105.

Room 12 (of Fisher).

(4) Doorway, in Philadelphia Mus. E 13560.

Private Apartments behind Throne Room.

Window, in Philadelphia Mus. E 13564. FISHER in *Penn. Mus. Journ.* xv (1924), fig. on p. 99; RANKE in *Penn. Mus. Bull.* xv [2-3] (Nov. 1950), fig. 64, p. 104; CAPART in *Chron. d'Ég.* xxxii (1957), fig. 32, p. 185; *id.* *Causeries sur l'Art égyptien*, fig. 22, p. 30.

Hall. 5 of Fisher.

EDGAR in *Ann. Serv.* xv (1915), pp. 97-104, with plan, views, and sketch of decoration, figs. 1, 2, and pl.

Columns. Texts, id. ib. pp. 100-1.

Doorways, names of the King on lintels and jambs (one doorway in Cairo Mus. JE 45029, and another, formerly in Cairo Mus. Temp. No. 3.2.21.1, now in Philadelphia Mus. E 13552). Texts, id. ib. pp. 102-4.

Bedroom. 10 of Fisher.

(5) Doorway, in Philadelphia Mus. E 13553-4. Lintel and jambs, royal names; FISHER in *Penn. Mus. Journ.* xv (1924), fig. on p. 94; ib. xvii (1926), fig. on p. 111 [middle].



Finds from the South Pylon and Palace areas

In Cairo Museum.

Statues.

Head,¹ variously identified but probably Nefertiti, quartzite, 'Amarna Period, in Cairo Mus. JE 45547. *Penn. Mus. Journ.* vi (1915), fig. 62 on p. 82; C. S. F[ISHER] in ib. viii (1917), fig. 88, p. 228; CAPART, *Documents*, i, pl. 30; id. *L'Art ég.* ii, pl. 346; *Encycl. phot. Caire*, pl. 102; DRIOTON and SVED, *Art ég.* fig. 82; LANGE, *Ägyptische Bildnisse*, pl. 20; BILLE-DE MOT, *Die Revolution des Pharaos Echnaton*, Abb. 77; ROEDER in *Ä.Z.* 83 (1958), Taf. iv [a], pp. 62-3; PETERSON in *Medelhavsmuseet Bulletin*, 4 (1964), fig. 8, p. 25; ALDRED, *N.K. Art* (1951), pl. 130; (1961), pl. 135; id. *Akhenaten*, pl. 8; id. *Akhenaten and Nefertiti*, fig. 37, p. 61; GILBERT in *Chron. d'Ég.* xxxvi (1961), figs. 10, 11, pp. 40-5; Paris. *Toutankhamon et son temps*. Petit Palais, 1967, Exhib. Cat. No. 12 with figs.; Brussels. *5000 ans*, fig. 25, p. 25 [34]; Vienna. *5000 Jahre*, No. 104 with Abb.; Stockholm. *5000 år*, No. 78 with fig.; London. *5000 Years*, pl. xxii, p. 18 [59]; Essen. *5000 Jahre*, No. 97 with Abb.; Amsterdam. *5000 jaar*, fig. 22 [59]; Louisiana. *5000 års*, No. 155 with fig.; MICHALOWSKI, *Art*, fig. 455; BRINKMANN in *Jahrbuch der Staatlichen Kunstsammlungen in Baden-Württemberg*, iv (1967), fig. 7, p. 14; PAVLOV in *Vestnik Drevney Istorii*, 1972, No. 4 (122), fig. 2, p. 90; PERC, *Spomeniki starega Egipta* (1974), No. 26 with fig.; *Le Règne du Soleil. Akhnaton et Nefertiti*. Exposition . . . Bruxelles, 17 janvier-16 mars 1975, No. 18; *Echnaton, Nofretete, Tutanchamun*. Ausstellung . . . Wien, 23. April-29. Juni 1975, No. 18; *Solens rike. Akhnaton, Nefertiti, Tut-ank-Amon*. Utstillingen . . . Oslo, 16. juli-16. september 1975, No. 18 with pl. 6; *Echnaton och Nefertiti*. Utställning . . . Stockholm, 16 oktober-7 december 1975, No. 18 with pl. 6; *Nofretete, Echnaton*. Ausstellung . . . München, 17. Januar-21. März 1976, No. 54; *Nofretete, Echnaton*. Ausstellung . . . Berlin, 10. April-16. Juni 1976, No. 54; *Echnaton, Nofretete, Tutanchamun*. Ausstellung . . . Hildesheim, 15. Juli-26. September 1976, No. 54; FATON in *Archeologia*, No. 80 (March 1975), fig. on p. 63 [upper]; HARRIS in *Gutenberghus Årsskrift*, 1976, fig. on p. 11; *Akhnaton og Nefertiti* in *Louisiana Revy*, 17 [1] (Oct. 1976), fig. on p. 1 [54]. See *Descr. somm.* No. 6212.

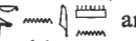
Small glass head, possibly of Merneptah, JE 46416. COONEY, *Glass Sculpture in Ancient Egypt* in *Journal of Glass Studies*, ii (1960), figs. 20-1, p. 28.

May  Overseer of works in the Temples of Rē and Ptaḥ, son of Bekenamūn  and Takertia , squatting, with cartouches of Merneptah on shoulders, granite, JE 67878. HABACHI in *Chron. d'Ég.* xxix (1954), figs. 27-8, pp. 213-16; *Ramsès le Grand* (Galeries Nationales du Grand Palais, Paris, 1976), Cat. xiii; *Bible et Terre Sainte*, No. 185 (Nov. 1976), fig. 8. Text and notes, GRDSELOFF MSS. 3.5.

¹ Selected references.

Stelae.

Lower part of stela of year 24 (of Ramesses III) concerning presenting statue of Ramesses III to the Temple of Merneptah (Excav. No. 2882). SCHULMAN in *J.N.E.S.* xxii (1963), pl. vii, pp. 177-84. Text, KITCHEN, *Ram. Inscr.* v. 249-50 [74]. See HELCK in *J.N.E.S.* xxv (1966), pp. 32-41.

Ramesses III censes three barks on stands, JE 45548. PHILAD. photo. 34078.

Ramesses IX kneels with wine before Ptaḥ, year 13, JE 45567. Ib. 34073.

Rebaḥi  (or Baḥi?) before two figures of Amen-rē^c and Mut(?), upper part, Ramesside, JE 45557. SCHULMAN in *J.N.E.S.* xxiii (1964), pl. iii [upper], pp. 278-9.

Others, Ramesside, JE 45535, 45543, 45550, 45552. JE 45543, PHILAD. photo. 34037.

Lower part of donation-stela, Petubastis I before god, year 6, with text mentioning Yewerhen , Leader of foreign troops, etc., JE 45530. SCHULMAN in *J.A.R.C.E.* v (1966), pl. xiii [2], pp. 33-9. Text, DARESSY MSS. E.30 [6]. Localities Per-ḥenu and Per-sekhemkheper, see YOYOTTE in *Rev. d'Ég.* 13 (1961), pp. 93-4 [b]; 15 (1963), p. 90.

Ḥaṭḥor Mistress of Aphroditopolis before Ptaḥ, dedicated by Pinezem , Dyn. XXI, JE 45539.

Late Period stela, JE 45549. PHILAD. photo. 34049.



Blocks, etc.

Jamb with remains of text of Ramesses III, sandstone, JE 45570. GABALLA in *J.E.A.* 59 (1973), pl. xxxvii [2], fig. 3, p. 113 [3]; text, KITCHEN, *Ram. Inscr.* v. 230 [62].

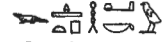

Offering-texts mentioning Queen Tausert, JE 45568. GABALLA in *B.I.F.A.O.* 71 (1972), pl. xxvi, fig. 4, p. 134.

Lintel-fragment of Shedsunefertem, Prophet of Ptaḥ, etc., kneeling before names of Siamūn, JE 45569.



In Philadelphia, University Museum.**Statues.**

Sebkḥotp-ḥenku , Greatest of the Directors of craftsmen, etc., son of Ressonb , warb-priest of Neith, and Neitnub , seated, headless, granite, Middle Kingdom, E 13647.

Senusert , son of Ḥetep, squatting, lower part, granite, Middle Kingdom, No. 29.75.484.

Werbauptah  [], squatting in cloak, fragment, basalt, Middle Kingdom, No. 29.75.502.



Amenophis IV, fragment of back pillar, sandstone, E 13644. LÖHR in *Studien zur alt-ägyptischen Kultur*, 2 (1975), pp. 149-50 with fig.

A Scribe of Ptaḥ, son of Teti , Scribe, and Ra'eres , kneeling, sandstone, Dyn. XIX, No. 29.75.525.

Merysekhmet , Mayor, holding stela with statuette of Ptaḥ, granite, Ramesside, E 13652.

An Overseer of the harīm, fragment of block-statue, Ramesside, No. 29.75.551.



Royal bust (name lost) holding inscribed staff, granite, New Kingdom(?), E 13653.

Kha'emwëset , warb-priest of Ptaḥ, etc., squatting, headless, dedicated by son Werkherp-ḥemut , Scribe, sandstone, New Kingdom, E 12038.

Neffronpet , Scribe of the fields of Amūn, block-statue, headless, sandstone, New Kingdom, E 13645.

Ptaḥwēr , Fashioner of gods of the Mansion of Gold, seated, lower part, New Kingdom, E 13661.

Upper part of seated statuette, granite, New Kingdom, E 13646.

Pain , son of Zepthaḥef'ankh , scribe-statue, headless, Dyn. XXI, E 13648. C. S. F[ISHER] in *Penn. Mus. Journ.* viii (1917), fig. 86, p. 228; PHILAD. photo. 34078.

Statue-base, inscribed, granite, Dyn. XXII–XXV, No. 29.75.544.

Foreign soldier, Dyn. XXVII or later, No. 29.75.499.

Seated man, Dyn. XXX–XXXI, No. 29.75.533.

An Overseer of the royal harīm, holding Ḥaṭḥor-head, fragment of block-statue, probably Late Period, No. 29.75.531.

Woman seated, lower part with remains of text, Late Period, No. 29.75.454.

Royal head, sculptor's model, Late Period or Ptolemaic, E 13658. *Penn. Mus. Journ.* vi (1915), fig. 64 on p. 84.



Statuettes of Ptaḥ. (a) Dedicated by Paḥemmeter , fragment, New Kingdom, No. 29.75.511. (b) Dedicated by a Chief royal scribe of the Lord of the Two Lands, alabaster base and feet, New Kingdom, E 13655. (c) Wearing feathered robe, headless, inscribed, faience, probably Dyn. XVIII, No. 29.84.482; *The Pennsylvania Gazette*, 77 [5] (March 1979), fig. on p. 33 [lower left].

Stelae.

Top of stela, Tuthmosis III seated, E 13623. PHILAD. photo. 34067.

Inḥertmosi , Outline-draughtsman, probably Dyn. XVIII, E 13595.

Ramesseid stelae. Titles of some, SCHULMAN in *J.A.R.C.E.* vi (1967), p. 154 note 4.

Amenemōpet , Mayor of Hermonthis and Dendera, King's son in the Wādi Naṭrūn, etc., with wife Ipa , granite, E 13608. PHILAD. photo. 34045.

Amenḥotp, E 13614.

Kauemperptaḥ , Sailor of the bark of Ptaḥ, E 13609. PHILAD. photo. 34075.

Kharu , Servant (*bsk*) of the Temple of Ptaḥ, E 13598.

Kha'emwēset , Governor of the Town and Vizier, Greatest of the Directors of craftsmen, etc., before Ptaḥ and Ma'et, faience, temp. Ramesses IX, E 13578. SCHULMAN in *Expedition*, 2 [4] (Summer 1960), fig. on p. 32, cf. p. 33.



Kha'y , Infantryman of the Residence, E 13613. PHILAD. photo. on 34070.

Mosi, E 13597.

Neferronpet , Servant (*sdm-rš*), upper part, E 13602.



Neḥeh , No. 29.75.561. PHILAD. photo. 34051.

Paserpanub , E 13612. See VANDIER in *Rev. d'Ég.* 17 (1965), p. 94 [D. cxiv].

Pashensekhmet , Overseer of works of Ptaḥ, and wife Tentnamensh , fragment, E 13618. PHILAD. photo. 34066.

Payneferptaḥ , Servant (*sdm*) of Ptaḥ, re-used basin, granite, E 13628.

Pedeḥnutpet , E 13624.

Ptaḥmay , *wab*-priest, with wife Nubemwaskhet , Songstress of Amūn, and family, E 13610. C. S. F[ISHER] in *Penn. Mus. Journ.* viii (1917), fig. 85, p. 227.

Puipeḥ(?) , E 13627.

Puy , Songstress, E 13592. PHILAD. photo. 33919.

Ra'meses-sauemyunu , Royal butler, E 13625. *Ib.* 34074.



Suemankhef , Scribe . . ., No. 29.75.565.

Ptaḥ and god Neḥi as bird, E 13621. SCHULMAN in *J.N.E.S.* xxiii (1964), pls. i, iii [fig. 1], pp. 275-6, 279.

Osiris seated, E 13589. Id. in *J.A.R.C.E.* vi (1967), pl. ii [8], p. 156 [8].

Head of ram of Amen-rē, E 13631. Id. ib. pl. i [4], p. 155 [4].

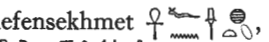
Others, E 13579-80, 13582-3, 13585-6, 13588, 13590-1, 13593-4, 13596, 13599-601, 13603-7, 13611, 13615-17, 13619-20, 13622, 13626, 13629-30, 13632, 13641, 13651, and Nos. 29.75.554, 557-8, 560, 563-4, 566-7, 574, 29.84.76, 742, 29.85.732. E 13605 and 13607, on PHILAD. photo. 34070; E 13630, ib. 33921, 34050.

Ānkhfensekhmet , Incense-bearer of Ptaḥ, son of Ababsunüter-nehktef 
, Late Period, E 13581. PHILAD. photo. 34043.

Blocks, etc.

Lintel of Sethos I, E 13573. See RANKE in *Penn. Mus. Bull.* xv [2-3] (Nov. 1950), p. 100. [Ramesses II] offers image of Maet to Ptaḥ, No. 29.75.555.

Lintel, Ramesses II kneels before Amen-rē as ram, E 13572. PHILAD. photos. 34011-12. See RANKE, op. cit. p. 100.

Lintel-fragment of Setau, Viceroy of Kush, etc., adoring names of Ramesses II, E 13566. SCHULMAN in *The Society for the Study of Egyptian Antiquities Journal*, viii (1978), pl. iv, pp. 42-5 (as E 13655); PHILAD. photo. 34115. Text, KITCHEN, *Ram. Inscr.* iii. 111 [65] (as E 13655). See RANKE, op. cit. pp. 99-100.

Lintel-fragment(?), Ramesses III kneels with image of Maet before Ptaḥ in kiosk, E 13570.

Lintel, double-scene, Neferronpet , Governor of the Town and Vizier, etc., kneels before cartouches of Ramesses VI, E 13567. CHRISTOPHE in *Bull. Inst. Ég.* xxxvii [1] (1954-5), pl. viii, pp. 24-5 [2]. See RANKE, op. cit. p. 100.

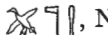
Offering-table cut out from block of Paḥemner , New Kingdom, E 13684.

Trial-piece(?), male head, Late Period, E 13643. C. S. F[ISHER] in *Penn. Mus. Journ.* viii (1917), fig. 87, p. 228; *MASCA Journal*, 1 (Dec. 1978), fig. on p. 3 [right].

Trial-piece, *recto*, man holding lion, *verso*, hawk, uraeus, and altar, Late Period, E 13634.

Other finds.

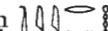
Lower part of niche with statuette of Tyerneḥ , Fan-bearer on the right of the King, with deceased kneeling adoring on sides, granite, New Kingdom, E 13662.

Location unknown. Some possibly in Cairo Mus.

Statues.

Bust with cartouche of Ramesses III on shoulder, granite.

Penmehyt holding headless figure of Ptaḥ, New Kingdom (Excav. No. 2218).

Amenardais , Director of the Palace, Scribe of the royal documents in the presence, statue-base, Dyn. XXVI (Excav. No. 11821).

Stelae. Ramesside unless stated.

Ānkh-ptāḥ , Carrier of the offering-table of Ptaḥ, before Ptaḥ and Sekhmet (Excav. No. 2906). PHILAD. photo. 34029.

Ḥatnūfer , adores Amen-rē, Ptaḥ, lion-headed goddess and Amenōpet (Excav. No. 3634). Ib. 34041.

Nezem , upper part (Excav. No. 3201).



Paḳer . . . , with Reshef at top. PHILAD. photo. 34054.

Stankh , Field-worker of the Temple of Ptaḥ, with two figures of Ptaḥ (Excav. No. 2766). SCHULMAN in *J.N.E.S.* xxiii (1964), pl. ii, pp. 278-9 [2].

Stankh adores Sobk (Excav. No. 2673).

Small stelae, Ptaḥ seated, Ḥathor-head, etc., on re-used blocks. SCHULMAN in *J.A.R.C.E.* vi (1967), pls. i [1-3], ii [5-7], pp. 154-6 [1-3, 5-7].

Others, Excav. Nos. 1689, 2090, 2774, 2786, 2840-2, 2907, 2992, 3108, 4696. Excav. Nos. 1689, 2907, 3108, PHILAD. photos. 34106, 34069, 34058.

Pedeneit , son of Neitemḥēt  (mother), followed by brother 'Ankh-weḥebrē , Dyn. XXVI (Excav. No. 1802). PHILAD. photos. 34046-7.

Tawertemḥab , (woman) seated, Dyn. XXVI (Excav. No. 2795).

Jambs, lintels, blocks, etc.

Sethos I (Excav. No. 2667).





Ramesses II, (a) and Merneptah (Excav. No. 4350); PHILAD. photo. 34080; (b) usurped by Setnakht (Excav. No. 4373).

Merneptah, (a) Excav. No. 4353; (b) offers image of Ma'et to Ptaḥ in kiosk; PHILAD. photo. 34022; (c) between Thoth and Horus; ib. 34021.

Ramesses III (Excav. No. 4372); PHILAD. photo. 34082.

Ramesses IX holding two ointment-jars (Excav. No. 9348).

Ramesses XI (Excav. No. 6773).



Others, New Kingdom unless stated. Amenemōnet , First prophet of Amūn; PHILAD. photo. 38723. Amenemōpet, Overseer of the granary, etc., temp. Ḥaremḥab, re-used; ib. 38718-19. Bekenamūn, Greatest of the Directors of craftsmen(?); ib. 38722. Ḥēt , Overseer of prophets of all the gods of Panopolis, First prophet of Min. Ḥori , Governor of the town and Vizier, adores names of Setnakht; ib. 38605. Kha'em-wēset (Excav. No. 7182). Ptaḥmosi, Greatest of the Directors of craftsmen (Excav. No. 4370). Ra'mosi, Scribe, Director of all works before His Lord; ib. 38371-2, 38688. To , Vizier, temp. Ramesses III. King near building with two columns (Excav. No. 2903). Three kneeling Libyans, Dyn. XVIII (Excav. No. 2889).



MISCELLANEOUS FROM KŌM EL-QAL'Ā

Statues.

Semtu-tefnakht , Overseer of crews of royal boats, etc., squatting with left knee up, headless, granite, temp. Psammetikhos I, in Cairo Mus. CG 653. BORCHARDT, *Statuen*, ii, Bl. 120, p. 197. Text, MARIETTE, *Mon. div.* pl. 34 [g]; DARESSY in *Ann. Serv.* xviii (1919), pp. 30, cf. 29; WILBOUR MSS. 3 C. 74.

Neferebrēc-nūfer , (i.e. Ir'ahor, Ṣaqqāra tb. LS 23), holding naos of Ptaḥ, faience, temp. Psammetikhos II, in Cairo Mus. CG 807. BORCHARDT, op. cit. Bl. 149, pp. 104-5. Texts, MARIETTE, op. cit. pl. 34 [a]; PIEHL, *Inscr. hiéro.* 3 Sér. lxxi-lxxii [I]; part, DE ROUGÉ, *Inscr. hiéro.* pls. xlv, xlvi. See MASPERO, *Guide*, p. 448 [4238].



Ḥor , son of Penen , block-statue, face destroyed, slate, Dyn. XXVI, in Boston Mus. 29.731. DUNHAM in *J.E.A.* xv (1929), pl. xxxiii, p. 165. Parts of text, BRUGSCH, *Recueil*, pl. iv [6]; MARIETTE, op. cit. pl. 34 [b]; MÜLLER (W. Max) in *Rec. Trav.* xxvi (1904), pp. 33 [top], cf. 32.

Pikha's , General of the Residence, etc., son of 'Ankh-hap  and Hathor-emakhet , headless, holding figure of Apis, schist, Dyn. XXX or Ptolemaic, in Cairo Mus. CG 1085. BORCHARDT, *Statuen*, iv, Bl. 162, pp. 49-50. Text, MARIETTE, op. cit. pl. 34 [c]; DARESSY in *Rec. Trav.* xv (1893), p. 157 [5].

Hawk protecting King, Late Period(?), in Cairo Mus. JE 33262. HORNEMANN, *Types*, v, pl. 1309. See *Bull. Inst. Ég.* iii Sér. 9 (1898), p. 413.



Man holding naos of Harpocrates, Ptolemaic, in Cairo Mus. JE 33266. MASPERO, *Égypte*, fig. 485. See id. *Guide*, p. 226 [973]; *Bull. Inst. Ég.* iii Sér. 9 (1898), p. 413.

Stelae.

Pakharu , Door-keeper of the Temple of Ptaḥ, son of 'Ankh-khons  and Heresibnes , Horus on crocodiles, Dyn. XXVI, in Cairo Mus. CG 9405. DARESSY, *Textes et dessins magiques (Cat. Caire)*, pls. v, vi, pp. 15-17.

Fragment with trilingual decree (of year 6) of Ptolemy IV Philopator, granite, in Cairo Mus. CG 31088. KAMAL, *Stèles Ptolémaïques et Romaines (Cat. Caire)*, pl. lxxiv (as 21088 in error), pp. 218-19; SPIEGELBERG, *Die demotischen Inschriften*, Taf. ii, pp. 14-20; PERDRIZET in *Bulletin de Correspondance Hellénique*, xxxv (1911), pl. ii, pp. 122-3. Ptolemy on horseback, MASPERO, *Égypte*, fig. 503. See MASPERO, *Guide*, p. 232 [995].

Ptolemy VI Philometor in double-scene before divinities of Tanis and Thebes, with line of demotic below, in Cairo Mus. CG 22189. KAMAL, op. cit. pl. lxiv, pp. 187-8. Text, DARESSY in *Rec. Trav.* xxiv (1902), p. 166 [cciii].

Stela of Pa'r'ashthereth  or Pa'ri , son of Shemrebi  (mother), Horus on crocodiles, with hieroglyphic and Phoenician texts, greywacke, on limestone pedestal with offering-basin, Ptolemaic, in Cairo Mus. CG 9402. DARESSY, *Textes et dessins magiques (Cat. Caire)*, pls. ii, iii, pp. 3-11; LACAU in *Mon. Piot*, xxv (1921-2), pl. xvi, figs. 4-6, pp. 195-6, 199-201. *Recto*, BORCHARDT, *Works of Art*, pl. 29; DE WIT, *Oud-Egyptische Kunst*, fig. 142 facing p. 225 (with pedestal); ROEDER, *Der Ausklang der ägyptischen Religion* [etc.], Taf. 10 (with pedestal), Abb. 6, p. 162; LEIBOVITCH, *Anc. Eg.* fig. 139; LOUKIANOFF in *Bull. Inst. Ég.* xiii (1930-1), pl. iii [14] (as CG 9404), p. 79; xxi (1938-9), pl. vi, p. 261; PICARD in *Société Royale d'Archéologie, Alexandrie. Bulletin*, n.s. x [1] [No. 32] (1938), fig. 3, p. 14; DRIOTON, *La magie dans l'Égypte des Pharaons in Formes et Couleurs*, xi [1] (1949), 4th fig.; PIRENNE, *Hist. civ.* iii, pl. 107 facing p. 392; SEELE in *J.N.E.S.* vi (1947), pl. iii [B], pp. 43, 48. Parts of text, KLASSENS, *A Magical Statue Base* [etc.], pp. 37-8, 46-50 [C 3]. See MASPERO, *Guide*, p. 490 [4751].

Blocks.

Block (perhaps stela) with cartouches of the Aten and Amenophis IV on three sides, in Cairo Mus. MARIETTE, *Mon. div.* pl. 34 [e]. Text, SANDMAN, *Texts from the Time of Akhenaten*, p. 161 [clxxvii]; LEGRAIN, *Répertoire*, No. 299. See LÖHR in *Studien zur altägyptischen Kultur*, 2 (1975), pp. 151-2 with fig. (from MARIETTE).

Rameses II holds captives, in Cairo Mus. JE 46189. BRUYÈRE, *Rapport sur les fouilles de Deir el Médîneh (1935-1940)*, iii, fig. 5, p. 63; MITRY, *Illus. Cat.* No. 769; FORMAN (W. and B.) and VILÍMKOVÁ, *Eg. Art*, pls. 85-6; DE RACHEWILTZ, *Vita nell'antico Egitto*, Tav. v [lower]; upper part of King, MYŚLIWIEC, *Le Portrait royal dans le bas-relief du Nouvel Empire*, pl. cx [244]. See *Descr. somm.* No. 769.

Others.

Offering-table of Amenemḥet I, granite, in Cairo Mus. Text, MARIETTE, *Mon. div.* pl. 34 [f].

Sistrum of Darius I, faience, in Cairo Mus. CG 69324. HICKMANN, *Instruments de Musique (Cat. Caire)*, pl. lviii, p. 85; id. in *Bull. Inst. Ég.* xxxvi (1953-4), fig. 5, p. 591. Text, MARIETTE, *Mon. div.* pl. 34 [d]; POSENER, *La Première Domination Perse* [etc.], pp. 153-4 [102].

Bolt with lion, bronze, probably Ptolemaic, in Cairo Mus. JE 37765. DARESSY in *Ann. Serv.* vi (1905), pl. ii, pp. 237-8; PILLET in *ib.* xxiv (1924), fig. 3, p. 192 [2]; see VARILLE in *ib.* liii (1956), p. 86 with fig. 1 (from DARESSY).

Miscellaneous from Mît Rahîna

Statues.

Royal.

Upper part of Sesostris I, diorite, in Berlin (East) Mus. 1205. EVERS, *Staat aus dem Stein*, i, Taf. 45; HAMANN, *Äg. Kunst*, Abb. 170. Head, L. D. iii. 301 [82] (as Nektanebos I). See *Ausf. Verz.* p. 247 (as Nektanebos I); *Führer* (1961), p. 49.

Colossal head wearing White Crown, perhaps Sesostris I, granite, in Brit. Mus. 615. BUDGE, *Egyptian Sculptures in the British Museum*, pl. x. See *Guide (Sculpture)*, p. 39 [137].

Bust, perhaps of Sesostris II, granite, in Copenhagen, Ny Carlsberg Glypt. Æ.I.N. 659. SCHMIDT (V.) in *P.S.B.A.* xxviii (1906), pp. 268-9 with pl.; id. *Den Æg. Sam.* (1908), pp. 81-4 with fig. [E.40]; id. *Choix* (1910), pl. vi [10], pp. 19-20; id. *Levende og Døde*, fig. 256; EVERS, *Staat aus dem Stein*, i, Taf. 69; MOGENSEN, *Coll. ég.* pl. ii [A 3], pp. 5-6; KOEFOED-PETERSEN, *Cat. des statues*, pl. 21, pp. 15-16 [19]; id. *Ægyptisk Billedhuggerkunst*, pl. 11; id. *Eg. Sculpture* (1951), pl. 11; (1961), pl. 15; ALDRED, *M.K. Art*, pl. 42.

Colossal head, perhaps of Amenophis II, in Cairo Mus. CG 641. BORCHARDT, *Statuen*, ii, Bl. 118, pp. 187-8. See VANDIER in *Mon. Piot.* xliii (1949), p. 8 with fig. 6 [d] (from BORCHARDT).

Headless kneeling statue of Amenophis III with offering-table, cartouche erased, quartzite, in Cambridge, Fitzwilliam Mus. E.82.1913.

Fragment of back pillar with Aten cartouches, perhaps from statue of Amenophis IV, quartzite, in Copenhagen, Ny Carlsberg Glypt. Æ.I.N. 1144. MOGENSEN, *Coll. ég.* pl. iii [A 7], p. 6; id. in *B.I.F.A.O.* xxx (1930), pl. i [2], p. 458; KOEFOED-PETERSEN, *Cat. des statues*, pl. 52, p. 28 [45] (as granite). Text, SANDMAN, *Texts from the Time of Akhenaten*, p. 184 [bottom]. See LÖHR in *Studien zur altägyptischen Kultur*, 2 (1975), pp. 148-9 with fig. (after MOGENSEN).

Sethos I (or II). Text on back, BRUGSCH, *Thes.* 1066 [9].

Seated god, with [Sethos I] between knees, granite, in Cairo Mus. CG 1293. HORNEMANN, *Types*, iv, pl. 1127. Text, BORCHARDT, *Statuen*, iv, pp. 151, cf. 150; KITCHEN, *Ram. Inscr.* i. 124 [64].

Colossus of Ramesses II wearing Blue Crown and holding standards of Ptaḥ and Thoth, granite, found at Hod el-Wissada. EL-AMIR in *Ann. Serv.* xlii (1943), pls. xxi, xxii, pp. 359-63; KINROSS, *Portrait of Egypt*, 3rd pl. after p. 16; WILDUNG, *Egyptian Saints. Deification in Pharaonic Egypt*, fig. 10. Texts, KITCHEN, *Ram. Inscr.* ii. 496 [193, A]; of standards, ČERNÝ Notebook, 118, p. 1. See *Chron. d'Ég.* xxi (1946), pp. 55-6.

Statue-base with names of Ramesses II and Queen Merytamün. DARESSY MSS. E.30 [8].

Statue-base of Ramesses II. WILKINSON MSS. xiii. 36 [upper].

Ramesses II holding standard, fragments, granite, in Cairo Mus. Temp. No. 31.12.38.1.

Texts, DARESSY in *Ann. Serv.* xx (1920), pp. 167–8 [1]; KITCHEN, *Ram. Inscr.* ii. 494–5 [192, A].

Adoring baboon protecting King, probably Sethos II, granite, in Vienna Mus. Inv. 5782. DEMEL, *Ägyptische Kunst*, Abb. 23; *Meisterwerke. Führer durch das Kunsthistorische Museum*, 1 (1958 and 1968), fig. 14; MICHALOWSKI, *Art*, fig. 539; VANDIER, *Manuel*, iii, pl. cxxx [4] (from DEMEL), p. 645. See REINISCH, *Miramar*, p. 243 [59].

Statue-base(?) of Ramesses III, usurped by Ramesses IV and VI. BRUGSCH, *Recueil*, pl. iv [2]. See CHRISTOPHE in *Bull. Inst. Ég.* xxxvii [1] (1954–5), pp. 22–3 [4].

Ramesses VI, head and legs lost, granite, in Berlin (East) Mus. 7701. Muzeul de artă, Bucharest. *Egiptul antic* [etc.] (1975), No. 71 with fig. on p. 38. Texts, *Aeg. Inscr.* ii, p. 85. See *Ausf. Verz.* p. 120.

Fragment of seated statue, granite, New Kingdom(?), in Cairo Mus. CG 1206. See BORCHARDT, *Statuen*, iv, p. 107.

Fragment of statue of Apries kneeling with figure of Ptaḥ, alabaster, in Cairo Mus. CG 1052. Text, BORCHARDT, *Statuen*, iv, p. 39.

Head, perhaps of Amasis, schist, in Louvre, E.25480. VANDIER in *A.Z.* 90 (1963), Taf. xi, xii, pp. 115–18. See id. in *La Revue du Louvre*, xii (1962), p. 294 with note 14.

Royal head (sculptor's model), Dyn. XXVII, in Budapest, Szépművészeti Múzeum, 60.17. VARGA in *Bulletin du Musée National Hongrois des Beaux-Arts*, 18 (1961), fig. 2, pp. 3–7; id. *Egyptomi kiállítás. Vezető* (1976), pl. 47; id. and WESSETZKY, *Egyptomi kiállítás* (1961), pl. xv [2]; (1964), pl. xvi [2]; id. *Az ókori Egyiptom. Kiállításvezető* (1970), pl. 28.

Achoris kneeling, lower part, diorite, in Cairo Mus. CG 681. BORCHARDT, *Statuen*, iii, Bl. 124, p. 25.

Ptolemy XII Neos Dionysos, granite, in Berlin (East) Mus. 8810. See *Ausf. Verz.* p. 324 (as Ptolemy X, i.e. IX Soter II); BOTHMER in *La Revue des Arts*, ix (1959), p. 107 note 26.

Private.

Ḥetepdief  kneeling, with names of Kings Ḥetepsekhemui, Ra'neb and Ninüter, granite, late Dyn. II or Dyn. III, in Cairo Mus. CG 1. BORCHARDT, *Statuen*, i, Bl. 1, pp. 1–2; WEIGALL, *Anc. Eg. . . . Art*, 13 [left]; JÉQUIER in DE MORGAN, *Recherches*, ii, pl. iv, fig. 852; PETRIE, *History*, i (1894), fig. 18; (1923), figs. 19–20 (= PETRIE Giza photo. 501); VON BISSING, *Äg. Kunstgeschichte*, Taf. lxiv [391], *Text*, i, p. 39; id. in *Rev. Arch.* 4 Sér. xv (1910), fig. 35, p. 259; MASPERO, *Égypte*, fig. 137; id. in GRÉBAUT, *Le Musée Égyptien*, i, pl. xiii, figs. 1, 2, pp. 12–13; CAPART, *Les Débuts de l'art en Égypte*, fig. 180; id. *Primitive Art in Egypt*, fig. 196; CAROTTI, *L'Arte*, fig. 36; MITRY, *Illus. Cat.* No. 3072; BYVANCK, *De Kunst* (1947), pl. xiv [49]; SMITH, *Hist. Eg. Sculp.* pl. 2 [b], p. 16; HORNEMANN, *Types*, iii, pl. 557; SHOUKRY, *Privatgrabstatue*, Abb. 1; GIEDION, *The Eternal Present*, ii, figs. 219–20; WOLF, *Kunst*, Abb. 33, pp. 60–1; id. *Die Kultur Ägyptens*, Abb. 52; LANGE and HIRMER, *Ägypten. Architektur* (1967), pl. 7; TERRACE and FISCHER, *Treasures*, pp. 25–8 with pls.; *Great Museums*, pls. 12, 13; WESTENDORF, *Das Alte Ägypten*, fig. on p. 26; MICHALOWSKI, *Art*, fig. 183; VANDERSLEYEN, *Das Alte Ägypten*, Abb. 122, fig. 62 on p. 220; SUZUKI, *Sculpture of the World*, 3, *Egypt*, pl. 29; LECLANT and others, *Le temps des Pyramides*, fig. 173. Royal names, MORET in *Mélanges Maspero*, i [2], fig. 1, p. 624. See MASPERO, *Guide*, p. 300 [3072].

Kawa'ḥ, King's son of his body (of Khufu), Chief Justice and Vizier (Giza tb. G 7110+7120), seated, restored by Kha'emwaset (son of Ramesses II), lower part, diorite, in Cairo Mus. JE 40431. GOMAA, *Chaemwese* [etc.], Taf. iv, Abb. 19, p. 84 [51].

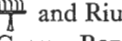
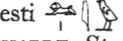
Menkheperresonb , Overseer of foreign countries, Chief of the Meza, etc., son of Neferkhaut  and Riuresti , block-statue, granite, temp. Tuthmosis III, in Cairo Mus. CG 547. BORCHARDT, *Statuen*, ii, Bl. 91, pp. 92-4; HORNE-MANN, *Types*, ii, pl. 446. Text, SETHE, *Urk.* iv. 991-4 [291].

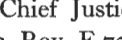
Neferweben , Chief Justice and Vizier, seated, headless, granite, temp. Tuthmosis III, in Brussels, Mus. Roy. E.7333. CAPART in *Bull. Mus. Roy.* 3 Sér. x (1938), fig. 21, pp. 114-16.

Sebkhotp, Overseer of the seal (Theb. tb. 63), seated on cushion reading, sandstone, fragment, temp. Tuthmosis IV, in Cairo Mus. CG 1090. BORCHARDT, *Statuen*, iv, Bl. 162, p. 51. Text, HELCK, *Urk.* iv. 1585 [519], cf. *Übersetz.* (1961), p. 164.

Haremhab (later King) as scribe,¹ granite, in New York, M.M.A. 23.10.1. WINLOCK in *M.M.A. Bull.* Pt. ii, Oct. 1923, pp. 3-4 with figs. on pp. 1, 5, 9, 13; id. in *J.E.A.* x (1924), pls. i-iv, pp. 1-5; id. *Egyptian Statues and Statuettes* (1937), fig. 19; ROSS, *The Art of Egypt*, pl. on p. 176; KEES, *Ägyptische Kunst*, Abb. 37; ROSTOVITZ, *A History of the Ancient World*, i, pl. xxx [1]; STEINDORFF, *Die Blütezeit des Pharaonenreichs* (1926), Abb. 190; id. and SEELE, *When Egypt Ruled the East*, fig. 95; SCHÄFER and ANDRAE, *Kunst* (1930 and 1942), 354-5; PILLET, *Thèbes. Palais et Nécropoles*, fig. 70; BOREUX in *Mon. Piot*, xxxiii (1933), fig. 1, p. 14; HAMMERTON, *Universal History of the World*, i, fig. on p. 668 (as Cairo Mus.); *A Guide to the Collections*, i (1934), fig. on p. 13; (1936 and 1937), fig. on p. 17; (1939 and 1940), fig. on p. 19; RANKE, *The Art of Ancient Egypt*, and BREASTED, *Geschichte Aegyptens* (1936), 141; HAMANN, *Äg. Kunst*, Abb. 273; HOYNINGEN-HUENE and STEINDORFF, *Egypt* (1943), fig. on p. 123; (1945), fig. on p. 128; CAPART, *L'Art ég.* ii, pl. 360; id. *Limites*, pl. iii [4], p. 44; SCOTT, *Egyptian Statues* (1945), 20th pl.; PIJOÁN, *Summa Artis*, iii (1945), figs. 455-6; CID PRIEGO, *El Arte Egipcio*, pl. facing p. 164 [upper]; WILSON, *The Burden of Egypt*, fig. 26a; ALDRED, *N.K. Art* (1951), pl. 169; (1961), pl. 171; id. *Akhenaten*, pl. 56; TAYLOR in *M.M.A. Bull.* n.s. x (April 1952), fig. on p. 221; BENDOW, *Stormaktstidens Egypt*, pl. facing p. 112 [right lower]; LANGE and HIRMER, *Aegypten. Architektur* (1955), pls. 196-7; (1957), pls. 198-9; (1967), pls. 202-3; WOLF, *Kunst*, Abb. 445; HAYES, *Scepter*, ii, fig. 190; HARI, *Horemheb*, figs. 4, 5, pl. vii, pp. 42-5; SMITH, *Art . . . Anc. Eg.* pl. 140, p. 207; DONADONI in *Enciclopedia dell'Arte Antica Classica e Orientale*, iii, fig. 329; PRITCHARD, *Anc. Near East*, fig. 418; *Guide to the Collections. Egyptian Art* (1962), fig. 39; MICHALOWSKI, *Art*, fig. 372; POULSEN (V.), *Ägyptische Kunst. Neues Reich und Spätzeit*, pl. on p. 61; GILES, *Ikhnoton: Legend and History*, pl. xiii [upper]; GROENEWEGEN-FRANKFORT and ASHMOLE, *Art of the Ancient World*, fig. 67 (as diorite); VANDERSLEYEN, *Das Alte Ägypten*, Abb. 201 [a]. Upper part or head, *A Brief Guide to the Egyptian Collection* (1946), fig. on p. 21; MÜLLER (H. W.) in *Münchener Jahrb.* 3 Ser. xviii (1967), Abb. 13, pp. 22-3 (as diorite). Text, HELCK, *Urk.* iv. 2089-94 [804], cf. *Übersetz.* (1961), pp. 393-5.

Teti, Head of *wacb*-priests, statue-group, Dyn. XVIII, in Cairo Mus. JE 44673.

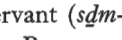
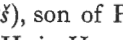
Piay , Servant (*sdm-cs*), son of Pawēr , block-statue with Hathor-emblem at front, schist, temp. Ramesses II, in Husson Colln. CLÈRE in *J.E.A.* 54 (1968), pls. xxii, xxiii, fig. 2, pp. 138-41, 145-8.

Rameses-smakhaset , Chief steward in the Temple of the ka of Ptah, etc., bust, granite, temp. Ramesses II, in Hildesheim Mus. 423. HABACHI in *Studia Aegyptiaca*, i (*Recueil . . . Wessetzky*), figs. 6-9, pp. 139-42. See IPPEL and ROEDER, *Die Denkmäler des Pelizaeus-Museums zu Hildesheim*, pp. 81-2.

Iyiry , Greatest of the Directors of craftsmen, block-statue with naos of

¹ Selected references.

Ptaḥ-Sokari, temp. Sethos II, in Louvre, A 71 [N.72]. CLARAC, *Musée de Sculpture* [etc.], v, pl. 997 [2558E], *Texte*, v, p. 302; VANDIER, *Manuel*, iii, pl. cliii [3], p. 672; ARCHIVES phot. E.7-LE-21. Texts, DEVÉRIA squeezes, Gal. Nat. Londres, 14. Name and titles, PIERRET, *Rec. inscr.* i, p. 10. See DE ROUGÉ, *Notice des monuments* (1883), pp. 37-8; VANDIER, *Guide* (1948), p. 14; (1952), p. 15; (1973), p. 23.

A Second prophet of Ptaḥ, head, granite, Dyn. XIX, in Harrow School Mus. 956. See BUDGE, *Cat. of the Egyptian Antiquities . . . of . . . Sir Gardner Wilkinson*, p. 86.

Female head, Dyn. XIX, in Dublin, National Mus. 1908.516. See MURRAY, *General Guide to the Art Collections*, iii, *Egyptian Antiquities*, p. 65.

Neferronpet $\frac{\text{𓆎}}{\text{𓆏}}$ $\frac{\text{𓆎}}{\text{𓆏}}$, Royal scribe in the Temple of Ptaḥ, son of Nebt-tauī $\frac{\text{𓆎}}{\text{𓆏}}$ $\frac{\text{𓆎}}{\text{𓆏}}$ (mother), lower part of kneeling statue with two small figures on either side, sandstone, New Kingdom, in Cairo Mus. JE 41642. HORNEMANN, *Types*, v, pl. 1367.

Granite torso (with recently added name of Amenophis I), New Kingdom, in Copenhagen, Ny Carlsberg Glypt. Æ.I.N. 32. See SCHMIDT, *Den Æg. Sam.* (1899), p. 108 [A.77]; (1908), pp. 150-1 [E.86].

A Fan-bearer on the right of the King, etc., probably New Kingdom. Text, BRUGSCH, *Thes.* 1065 [8].

Seated double-statue, Dyn. XVIII, usurped by Shedsunefertem, Greatest of the Directors of craftsmen, son of 'Ankhefensekhmet $\frac{\text{𓆎}}{\text{𓆏}}$ $\frac{\text{𓆎}}{\text{𓆏}}$ $\frac{\text{𓆎}}{\text{𓆏}}$ $\frac{\text{𓆎}}{\text{𓆏}}$, same title, and wife Tashepenēsi $\frac{\text{𓆎}}{\text{𓆏}}$ $\frac{\text{𓆎}}{\text{𓆏}}$ $\frac{\text{𓆎}}{\text{𓆏}}$ $\frac{\text{𓆎}}{\text{𓆏}}$, temp. Sesonchis I, granite, in Cairo Mus. CG 741. BORCHARDT, *Statuen*, iii, Bl. 137, pp. 67-9; WILDUNG and GRIMM, *Götter, Pharaonen* (1978), No. 52. Text, DARESSY in *Rec. Trav.* xviii (1896), pp. 46-9 [i]. Name and titles of wife, GRDSELOFF in *Ann. Serv.* xlvii (1947), p. 212. See KEES in *Ä.Z.* 87 (1962), pp. 140-2 [a].

Niche, dedicated by 'Ankh-sheshonḳ $\frac{\text{𓆎}}{\text{𓆏}}$ $\frac{\text{𓆎}}{\text{𓆏}}$ $\frac{\text{𓆎}}{\text{𓆏}}$ $\frac{\text{𓆎}}{\text{𓆏}}$, God's father, etc., with 6 statuettes of his ancestors, (a) 'Ankh-sheshonḳ, Head of the Heads of craftsmen of the Temple of Ptaḥ, etc., son of Iufta $\frac{\text{𓆎}}{\text{𓆏}}$ $\frac{\text{𓆎}}{\text{𓆏}}$, (b) probably his wife Tapert $\frac{\text{𓆎}}{\text{𓆏}}$ $\frac{\text{𓆎}}{\text{𓆏}}$, daughter of Pedēsi $\frac{\text{𓆎}}{\text{𓆏}}$ $\frac{\text{𓆎}}{\text{𓆏}}$ $\frac{\text{𓆎}}{\text{𓆏}}$ $\frac{\text{𓆎}}{\text{𓆏}}$, Great chief of the Ma, etc., (c) probably their son Thaenab $\frac{\text{𓆎}}{\text{𓆏}}$ $\frac{\text{𓆎}}{\text{𓆏}}$ $\frac{\text{𓆎}}{\text{𓆏}}$ $\frac{\text{𓆎}}{\text{𓆏}}$, Head of craftsmen of the Temple of Ptaḥ, etc., (d) his wife Esmerptah $\frac{\text{𓆎}}{\text{𓆏}}$ $\frac{\text{𓆎}}{\text{𓆏}}$ $\frac{\text{𓆎}}{\text{𓆏}}$ $\frac{\text{𓆎}}{\text{𓆏}}$, (e) their son 'Ankh-sheshonḳ, Head of craftsmen, etc., (f) his wife Nekhtubasterau $\frac{\text{𓆎}}{\text{𓆏}}$ $\frac{\text{𓆎}}{\text{𓆏}}$ $\frac{\text{𓆎}}{\text{𓆏}}$ $\frac{\text{𓆎}}{\text{𓆏}}$, sandstone, probably Dyn. XXV, in Cairo Mus. JE 36728. VERNUS in *B.I.F.A.O.* 76 (1976), pls. v, vi, pp. 3-15. Text, LEGRAIN in *Rec. Trav.* xxix (1907), pp. 174-8.

'Ankhemthenent $\frac{\text{𓆎}}{\text{𓆏}}$ $\frac{\text{𓆎}}{\text{𓆏}}$ $\frac{\text{𓆎}}{\text{𓆏}}$ $\frac{\text{𓆎}}{\text{𓆏}}$ $\frac{\text{𓆎}}{\text{𓆏}}$, with name of father(?) Iref'acnptah $\frac{\text{𓆎}}{\text{𓆏}}$ $\frac{\text{𓆎}}{\text{𓆏}}$ $\frac{\text{𓆎}}{\text{𓆏}}$ $\frac{\text{𓆎}}{\text{𓆏}}$, bust, quartzite, Dyn. XXV, formerly in Cairo Mus. JE 29878, now in New York, M.M.A. 07.228. 47. HOYNINGEN-HUENE and STEINDORFF, *Egypt* (1945), fig. on p. 168; BOTHMER, *Eg. Sculp.* pl. 10 [23-5], pp. 11-12 [10].

Pedēsi $\frac{\text{𓆎}}{\text{𓆏}}$ $\frac{\text{𓆎}}{\text{𓆏}}$ Ḥarkhebi $\frac{\text{𓆎}}{\text{𓆏}}$ $\frac{\text{𓆎}}{\text{𓆏}}$ $\frac{\text{𓆎}}{\text{𓆏}}$ $\frac{\text{𓆎}}{\text{𓆏}}$, block-statue, Dyn. XXV-XXVI, in Cairo Mus. CG 659. See BORCHARDT, *Statuen*, iii, pp. 7-8 (text).

Amen(em)ōpetemḥēt $\frac{\text{𓆎}}{\text{𓆏}}$ $\frac{\text{𓆎}}{\text{𓆏}}$ $\frac{\text{𓆎}}{\text{𓆏}}$ $\frac{\text{𓆎}}{\text{𓆏}}$ $\frac{\text{𓆎}}{\text{𓆏}}$, Overseer of singers of Amūn of Ōpet, etc., son of Iḥsetpep $\frac{\text{𓆎}}{\text{𓆏}}$ $\frac{\text{𓆎}}{\text{𓆏}}$ $\frac{\text{𓆎}}{\text{𓆏}}$ $\frac{\text{𓆎}}{\text{𓆏}}$ $\frac{\text{𓆎}}{\text{𓆏}}$ (mother), kneeling (headless) holding Ḥathor-head, schist, temp. Psammetikhos I, in New York, M.M.A. 24.2.2. FISCHER in *Apollo*, lxxxiii (1965), fig. 8, p. 173; DE MEULENAERE in *Metropolitan Museum Journal*, 8 (1973), figs. 1-4, pp. 27-32; RUSSMANN in *ib.* figs. 1-3, pp. 33-46.

Nekht-ḥarḥebi $\frac{\text{𓆎}}{\text{𓆏}}$ $\frac{\text{𓆎}}{\text{𓆏}}$ $\frac{\text{𓆎}}{\text{𓆏}}$ $\frac{\text{𓆎}}{\text{𓆏}}$ $\frac{\text{𓆎}}{\text{𓆏}}$ Neferebrēc-sineit $\frac{\text{𓆎}}{\text{𓆏}}$ $\frac{\text{𓆎}}{\text{𓆏}}$ $\frac{\text{𓆎}}{\text{𓆏}}$ $\frac{\text{𓆎}}{\text{𓆏}}$ $\frac{\text{𓆎}}{\text{𓆏}}$, Royal herald, etc., son of Pede[neit], kneeling with naos of Ptaḥ, lower part, schist(?), temp. Psammetikhos II or later, in Berlin (East) Mus. 11332. See *Ausf. Verz.* pp. 256-7.



Pedubaste $\frac{\text{𓆎}}{\text{𓆏}}$ $\frac{\text{𓆎}}{\text{𓆏}}$ $\frac{\text{𓆎}}{\text{𓆏}}$ $\frac{\text{𓆎}}{\text{𓆏}}$ $\frac{\text{𓆎}}{\text{𓆏}}$ Weḥebrēc $\frac{\text{𓆎}}{\text{𓆏}}$ $\frac{\text{𓆎}}{\text{𓆏}}$ $\frac{\text{𓆎}}{\text{𓆏}}$ $\frac{\text{𓆎}}{\text{𓆏}}$, Royal scribe, etc., son of Usirinakht, kneeling with



offering-table, fragment, granite, temp. Apries, in Marseilles Mus. 210 (formerly attached to upper part of another statue). WILBOUR MSS. iii. D. 15-16. Some names, LIEBLEIN, *Dict.* No. 2339. See MASPERO, *Catalogue du Musée Égyptien de Marseille*, pp. 9-10 [10].

‘Aḥ[mosi]  (i.e. ‘Aḥmosi-sineit), Overseer of the antechamber, etc., kneeling with naos of Ptah, lower part, slate, temp. Amasis to Dyn. XXVII, in Cairo Mus. CG 666. Text, BORCHARDT, *Statuen*, iii, p. 14; DARESSY in *Rec. Trav.* xi (1889), p. 93 [xliii] (as basalt). (Head in Moscow Mus. I.I.a.5740 may join.)



Uzahorresnet , Greatest of the physicians, fragment of probably naophorous statue, granite, temp. Amasis to Darius I, in Michaelidis Colln. MICHAELIDIS in *Ann. Serv.* xliii (1943), figs. 34-5, pp. 101-2 [vii].

Upper part of scribe-statue, schist, early Dyn. XXVI, in New York, M.M.A. 25.2.1. WINLOCK, *Egyptian Statues and Statuettes* (1937), fig. 22; SCOTT, *Egyptian Statues* (1945), 27th pl.; BOTHMER, *Eg. Sculp.* pl. 20 [46], pp. 24-5 [21]; *Treasures from the Metropolitan* (Indianapolis Museum of Art, Oct. 25, 1970-Jan. 3, 1971), No. 58 with fig. (as Dyn. XXV).



Ḥarenḥap , Judge of the Great Place of the Temple of Ptah-Sokari-Apis, son of Ipi  and Zeubastes^cankh , kneeling, probably Dyn. XXVI, in Berlin (East) Mus. 10289. See *Ausf. Verz.* p. 258; *Führer* (1961), p. 77.

Ipy , Greatest of the Six, etc., son of Pedēsi , kneeling with naos, lower part, basalt, Dyn. XXVI, formerly in Turaev Colln., now in Leningrad, State Hermitage Mus. 2961. LAPIS and MAT'É, *Drevneegipetskaya skul'ptura v sobranii Gosudarstvennogo Ermitazha*, fig. 73, pl. iii [117], pp. 109-10. Text, TURAJEFF in *Ä.Z.* 48 (1910), p. 163 [iv]; WILBOUR MSS. 2 Q, 5 (giving provenance).

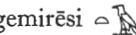
Ptahḥotp , Overseer of the Treasury, etc., head and feet lost, holding [naos], schist, temp. Darius I, in Brooklyn Mus. 37.353. COONEY in *Brooklyn Mus. Bull.* xv [2] (Winter 1953), figs. 1-5, pp. 2-16; BOTHMER, *Eg. Sculp.* pls. 60-1 [151-3], pp. 76-7 [64].

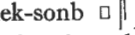
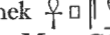
Psammethēk-sineit , Director of all craftsmen of the King in silver and gold, son of Zeptaḥef^cankh  and Tagemirēsi , kneeling with naos of Osiris, greywacke, Dyn. XXVII, in Cairo Mus. CG 726. BORCHARDT, *Statuen*, iii, Bl. 134, pp. 60-2; CAPART, *L'Art ég.* (1909), pl. 86; (1911), pl. 187 (upper part); id. *L'Art ég.* ii, pls. 385-6; ROEDER, *Altägyptische Erzählungen und Märchen*, Taf. 11; BOSSE, *Die menschliche Figur*, Taf. vi [125], p. 49; LEBOVITCH, *Anc. Eg.* fig. 93; TULLI in *Miscellanea Gregoriana*, fig. 6, p. 217; BOTHMER, *Eg. Sculp.* pls. 61-2 [154-7], pp. 78-9 [65]; id. in *The Connoisseur Year Book 1962*, fig. 7, p. 37; HORNEMANN, *Types*, iii, pl. 615; TERRACE and FISCHER, *Treasures*, pp. 169-72 with pls.; PERC, *Spomeniki starega Egipta* (1974), No. 36 with fig. Upper part or head, OFFORD in *P.S.B.A.* xxi (1899), pl. facing p. 80; SPIEGELBERG, *Geschichte*, Abb. 77; VON BISSING, *Denkmäler*, Text to Taf. 108 [a] [figs.]; PIRENNE, *Hist. civ.* iii, pl. 39 facing p. 161; RICHTER in *The Journal of Roman Studies*, xlv (1955), pl. iv [14], p. 43 with note 32. See MASPERO, *Guide*, p. 203 [824]; BRUGSCH in *Bull. Inst. Ég.* iii Sér. 7 (1897), p. 144.

Psammethēk-sonb , Vizier, etc., son of ‘Ankh-psammethēk , God's father, *imy-ıwnt*, kneeling with naos of Atum, Dyn. XXIX, in Cairo Mus. CG 682. BORCHARDT, *Statuen*, iii, Bl. 124, pp. 26-7; GRDSELOFF in *Ann. Serv.* xl (1940), fig. 28, p. 189. Text, DARESSY in *Rec. Trav.* xiv (1893), pp. 177-8 [lxxii]; id. MSS. E.30 [8]. See YOYOTTE in *B.I.F.A.O.* liv (1954), pp. 93-4 [Doc. 6, b].



Esmiḥos , Overseer of the royal harīm, etc., son of Pedemiḥos , Prophet, kneeling with naos of Ptah, fragment, granite, Late Period, in Naples, Museo Nazionale, 1063. Text, WIEDEMANN in *Rec. Trav.* viii (1886), p. 68 [10]. Names and titles, LIEBLEIN,

Dict. No. 2363. See MARUCCHI in RUESCH, *Guida illustrata del Museo Nazionale di Napoli* (1911), p. 139 [425]; YOYOTTE in *B.I.F.A.O.* lii (1953), p. 184 note 2.

Pedepap , God's father, *sem*-priest, headless block-stature, Late Period, in Cairo Mus. CG 595. Text, BORCHARDT, *Statuen*, ii, p. 149.



Block-stature, Late Period, in Cairo Mus. CG 727. Id. ib. iii, Bl. 134, p. 62.

Head, faience, Late Period, in Cairo Mus. CG 808. Id. ib. iii, Bl. 149, p. 106; MARIETTE, *Album du Musée de Boulaq* (1872), on pl. 25; COTTRELL, *Egypt*, fig. 75.

Lower part of statue of daughter of Ḥarḥap  (mother), dedicated by brother Pedekhons , *wab*-priest of the gods of Memphis, etc., Ptolemaic, in Cairo Mus. JE 35351. Text, DARESSY in *Rec. Trav.* xiv (1893), p. 184 [lxxxiii]; xxiv (1902), p. 161 [cxciv].

Head ('Brooklyn Black Head'), with remains of text on back pillar, diorite, late Ptolemaic, in Brooklyn Mus. 58.30. BOTHMER, *Ag. Sculp.* frontispiece and pls. 123-4 [329-31], pp. 172-3 [132]; BRENDL in *A. J. A.* 71 (1967), pl. 120 [7], p. 408; CHARBONNEAUX in *Mélanges d'archéologie et d'histoire offerts à André Piganiol* (ed. CHEVALLIER), i (1966), fig. 12, p. 418; *Handbook* (1967), pl. on p. 96; *Brief Guide* (1970 and 1974), fig. on p. 90; WESTENDORF, *Das Alte Ägypten*, fig. on p. 228; WOLF, *Hochkulturen*, Abb. 58; FAZZINI, *Images for Eternity*, Cat. No. 117; *Ägyptische Kunst aus dem Brooklyn Museum* (Berlin, Ägyptisches Museum, 4. Sept.-31. Okt. 1976), No. 84; VANDERSLEYEN, *Das Alte Ägypten*, Abb. 236; *Égypte Éternelle. Chefs-d'œuvre du Brooklyn Museum* (Palais des Beaux-Arts, Bruxelles, 9 décembre 1976-20 février 1977), No. 84.

Part of head, basalt, Ptolemaic, in Brooklyn Mus. 57.42. BOTHMER, *Ag. Sculp.* pl. 98 [263], p. 136; FAZZINI, *Images for Eternity*, Cat. No. 115; *Ägyptische Kunst aus dem Brooklyn Museum* (Berlin, Ägyptisches Museum, 4. Sept.-31. Okt. 1976), No. 81; *Égypte Éternelle. Chefs-d'œuvre du Brooklyn Museum* (Palais des Beaux-Arts, Bruxelles, 9 décembre 1976-20 février 1977), No. 81.

Pedusiri , Prophet of Khem Lord of Letopolis, etc., son of Ḥar-ʿashakhet  and Ēsiwert , schist, Roman, formerly in Huber Colln., now in Cairo Mus. CG 696. BORCHARDT, *Statuen*, iii, Bl. 128, pp. 38-9; MASPERO, *Égypte*, fig. 484; id. *Guide*, fig. 78, p. 225 [971]; id. and ROEDER, *Führer*, Taf. 42 [a], p. 62 [720] (as granite); *Encycl. phot. Caire*, pl. 216; *Great Museums*, fig. 7 on p. 127; DONADONI, *Egyptian Museum Cairo*, pls. on pp. 156-7. Upper part, DRIOTON and SVED, *Art ég.* fig. 147; MICHALOWSKI, *Art*, fig. 695. Text, BRUGSCH, *Recueil*, pl. vii [2]; DARESSY in *Rec. Trav.* xv (1893), p. 159 [7].

Divinities, animals, sphinxes.



Torsos of two female sphinxes with name of Amenemḥet III, granite, in Vienna Mus. Inv. 5753-4. REINISCH, *Miramar*, p. 230 [5, 6] with Taf. xxix [2] (one). Inv. 5753, EVERS, *Staat aus dem Stein*, ii, Taf. xiv [68], p. 113; VON BISSING, *Äg. Kunstgeschichte*, Taf. lxxii [481], *Text*, ii, pp. 140 note 6, 147; KEIMER in *Ann. Serv.* xxxv (1935), pl. iv [b] (from EVERS), pp. 185, 190 [2], 191 [4]; SCHWEITZER, *Löwe und Sphinx im alten Ägypten*, Taf. ix [5], p. 44. See *Uebersicht* (1895), p. 33 [III]; (1923), p. 9 [III].

Ptaḥ seated, fragment, dedicated by Merneptah (son of Ramesses II, later King), diorite, in Berlin (East) Mus. 7553. Text, *Aeg. Inscr.* ii, p. 85; KITCHEN, *Ram. Inscr.* ii. 496-7 [193, B]. See *Ausf. Verz.* p. 122.

Ptaḥ, diorite, dedicated by Ramesses II, in Berlin (East) Mus. 2274. Text, *Aeg. Inscr.* ii, p. 86; KITCHEN, *Ram. Inscr.* ii. 497 [193, C]. See *Ausf. Verz.* pp. 121-2.

Lion devouring captive, temp. Ramesses II, in Cairo Mus. JE 37647. HAMZA in *Ann. Serv.* xxx (1930), fig. 6, p. 48; HORNEMANN, *Types*, v, pl. 1329.

Thoth, faience statue-base, dedicated by Bek(en)amūn, Overseer of foreign countries, New Kingdom, in Cairo Mus. JE 30139. See *Bull. Inst. Ég.* iii Sér. 3 (1892), p. 281.

Osiris, dedicated by Kharkhons , Door-opener, son of (U)serken , granite, 3rd Int. Period, in Blacas Colln. Texts, BLACAS in *Revue Égyptologique*, n.s. i (1919), pp. 39, 40-6.

Head of Neith, granite, Dyn. XXVI, in Brit. Mus. 659. See *Guide (Sculpture)*, p. 238 [872].

Head, probably of Hathor, Late Period, formerly in von Bissing Colln. PETRIE, *Memphis*, i, pl. xxxiii [lower middle], p. 13.

Colossal head, perhaps of Imhōtep, Late Period, in Copenhagen, Ny Carlsberg Glypt. Æ.I.N. 1384. MOGENSEN, *Coll. ég.* pl. xix [A 77], p. 20; KOEFOED-PETERSEN, *Cat. des statues*, pl. 121, p. 66 [I13].

Sphinx, Ptolemaic or Roman, in Cairo Mus. CG 1175. BORCHARDT, *Statuen*, iv, Bl. 165, p. 90.

Sphinx, Ptolemaic, in Baltimore, Johns Hopkins Univ. Mus. 9210. POOLE in *Art News*, xlvii [9] (Jan. 1949), fig. on p. 38 [upper].

Cache of bronze statuettes. Dyn. XXII or later. All formerly in Posno Colln.

Hôtel Drouot Sale Cat. May 22-6, 1883, Nos. 524, 468, 190, 266 with pls. vi, v, iii, iv. See *Antiquités égyptiennes . . . Collection de M. Gustave Posno* (1874), Nos. 524, 468, 190, 266; STERN in *Zeitschrift für die gebildete Welt*, iii (1883), pp. 285-7.

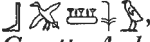
(a) Bepshes , Child of the Chief of a foreign country, in Louvre, E.7693. LONGPÉRIER in *Gazette Archéologique*, viii (1883), pl. 13, pp. 95-6; PERROT and CHIPIEZ, *Hist. de l'Art*, i, fig. 435; MASPERO, *L'Arch. ég.* (1887), fig. 272; (1907), fig. 296; VON BISSING in *Mitteilungen des Kaiserlich Deutschen Archäologischen Instituts, Athenische Abteilung*, xxxviii (1913), Abb. 8, pp. 253-7; FECHHEIMER, *Kleinplastik der Ägypter*, Taf. 105; BÉNÉDITE in *La Revue de l'Art ancien et moderne*, xliii (1923), fig. 6, p. 171; BOREUX, *Guide*, ii, pl. lvi [left], pp. 409-10; SCHMIDT, *Levende og Døde*, fig. 897; BOSSE, *Die menschliche Figur*, Taf. i [18], p. 18; MICHALOWSKI, *Art*, fig. 593; VANDIER, *Guide* (1948), pl. xv [2], p. 71; (1952), pl. xv [2], p. 73; (1973), pl. xix [1], p. 122; ARCHIVES phot. E.65. Name and title, YOYOTTE in *B.I.F.A.O.* lvii (1958), pp. 81-9 with fig. 1; REVILLOUT in *Revue Égyptologique*, iii (1885), p. 47 [bottom].

(b) Man, in Louvre, E.7692. LONGPÉRIER in *Gazette Archéologique*, viii (1883), pl. 12, pp. 94-6; PERROT and CHIPIEZ, *Hist. de l'Art*, i, fig. 434; VON BISSING in *Mitteilungen des Kaiserlich Deutschen Archäologischen Instituts, Athenische Abteilung*, xxxviii (1913), Abb. 7, pp. 253, 257-8; MASPERO, *Égypte*, fig. 538; RICHER, *Le Nu*, fig. 152; SCHMIDT, *Levende og Døde*, fig. 896; *Encycl. phot. Louvre*, i, pl. 108; CHARBONNEAUX, *Les Merveilles du Louvre*, i, pl. on p. 139 [left]. See BOREUX, *Guide*, ii, p. 333.





(c) Horus¹ pouring libation, in Louvre, E.7703. PERROT and CHIPIEZ, *Hist. de l'Art*, i, fig. 44; MASPERO, *Égypte*, fig. 539; id. *L'Arch. ég.* (1887), fig. 271; (1907), fig. 295; id. *Hist. anc.* i, fig. on p. 100; RICHER, *Le Nu*, fig. 153; STRÖMBOM, *Egyptens Konst*, fig. 213; BÉNÉDITE in *La Revue de l'Art ancien et moderne*, xliii (1923), fig. 5, p. 171; BOREUX, *Guide*, ii, pl. lvi [right], pp. 565-6; id. *L'Art ég.* pl. lviii; GAUCH in *Bulletin des Musées de France*, v (1933), fig. on p. 119; *Encycl. phot. Louvre*, i, pls. 120-1; DESROCHES, *L'Art égyptien au Musée du Louvre* (1941), fig. on 27th p. [upper]; RANKE, *The Art of Ancient Egypt*, and BREASTED, *Geschichte Aegyptens* (1936), 176; PIJOÁN, *Summa Artis*, iii (1945), fig. 274;

¹ Selected references.

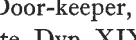
Two men Hori , each Greatest of the Directors of craftsmen, the 1st son of Kha'emwëset (son of Ramesses II), the 2nd father of Vizier Hori, and Kha'emwëset (father of 1st Hori), before Ptaḥ and Sekhmet, with relatives before Hāthor below, sandstone, late Dyn. XIX to early Dyn. XX, in Michaelidis Colln. MAYSTRE in *Ann. Serv.* xlvi (1948), pl. i, pp. 449-55.

Paḥemneter , Greatest of the Directors of craftsmen, etc., before Ptaḥ, granite, probably Dyn. XIX, in Cairo Mus. JE 27322. Text, DARESSY in *Rec. Trav.* x (1888), p. 150 [xiii].

Roma , Door-keeper, with paralysed leg, and wife Imaia  and son, dedicated to Astarte, Dyn. XIX, in Copenhagen, Ny Carlsberg Glypt. Æ.I.N. 134. MADSEN in *Å.Z.* 41 (1904), pp. 114-15 with fig.; MOGENSEN, *Coll. ég.* pl. cvii [A 724], p. 99; SCHMIDT, *Den Æg. Sam.* (1908), pp. 180-3 [E.111] with fig.; id. *Choix* (1910), pl. xiv [29], pp. 28-9; *Levende og Døde*, fig. 493; SLOMANN in *Bulletins et Mémoires de la Société d'Anthropologie de Paris* (1927), fig. 8, p. 76; DAWSON, *Magician and Leech*, pl. i (frontispiece), p. 107; RANKE in *Studies Presented to F. Ll. Griffith*, pl. 66, pp. 413-14; PIJOÁN, *Summa Artis*, iii (1945), fig. 605; WOLF, *Die Welt der Ägypter*, Taf. 107; KOEFOED-PETERSEN, *Les stèles égyptiennes*, pl. 44, pp. xxxv, 35-6, 74; WATERMANN, *Bilder aus dem Lande des Ptaḥ und Imhotep*, Abb. 20, p. 44; SIGERIST, *A History of Medicine*, i, pl. viii [20]; RIAD, *La Médecine au temps des Pharaons*, fig. 56; HARRISON in *The Biblical Archaeologist*, xvi (1953), fig. 14, p. 89; MAZAR, *Views*, ii, pl. 167; GHALIOUNGUI, *Magic and Medical Science* (1973), pl. 21; BRUNNER-TRAUT, *Die Alten Ägypter*, Taf. 48; LECA, *Médecine*, pl. ix; WELLS, *Bones, Bodies and Disease*, pl. 44. Deceased, TOLSTOÏ, *Étude des Représentations Pathologiques dans l'Art Égyptien*, fig. 7, pp. 78-80. Texts, KOEFOED-PETERSEN, *Rec. inscr.* p. 59 [134].

Seba , Overseer of the cattle of Ptaḥ, and wife Wert-khenr(eti) , three registers, I, deceased and two female relatives before Osiris and Sons of Horus, II, deceased and wife kneeling before Apis-bull, III, Mosi , Craftsman of the Place of Truth, and his wife Ēsinefer(t) , kneeling before Hāthor-cow, incomplete, Dynasty XIX, in Florence Mus. 2541. BEREND, *Principaux monuments*, pl. vii, pp. 52-3; SPIEGELBERG, *Ägyptologische Mitteilungen in Sitzungsberichte der Bayerischen Akademie der Wissenschaften*, Philos.-philol. und hist. Kl. (1925), 2. Abhand. Taf. iv (from BEREND), pp. 20-1, 22-4; BOSTICCO, *Le stèle egiziane del Nuovo Regno*, fig. 53, pp. 59-61; ALINARI photo. 43809 [left]; MARBURG INST. photo. 628883. Apis-bull, LANZONE, *Diz.* Tav. cci [1], p. 530. Names and titles, LIEBLEIN, *Dict.* Nos. 785, 2074. See ROSELLINI, *Breve Notizia degli Oggetti di Antichità Egiziane* [etc.] (1830), p. 93 [106]; SCHIAPARELLI, *Mus. Arch. Firenze*, pp. 360-2 [1624] (text); MASPERO in *Rec. Trav.* ii (1880), p. 179 [xxxix]; MIGLIARINI, *Indication*, p. 16.

Names lost, with Ptaḥ and Termuthis in upper register, Dyn. XIX, in London, Univ. Coll. 14572. STEWART, *Ég. Stelae*, i, pl. 28 [2], p. 36.





Kha , Barber, before Ptaḥ, Ramesside, in London, Univ. Coll. 14427. Id. ib. pl. 29 [1], p. 36.

Fragment, two faces, (a) two men (one a General, Overseer of a fortress, etc.) adoring, (b) Ptaḥ and Sekhmet, quartzite, Ramesside, in London, Univ. Coll. 14578. Id. ib. pl. 29 [8], p. 38.

Name much effaced, with Tuthmosis IV smiting enemies before Ptaḥ, probably Ramesse-side, in Hanover, Kestner-Mus. 1935.200.230. MUNRO in *Städel-Jahrbuch*, N.F. 3 (1971), p. 35 [32] with fig.



Paḥu , Tallow-chandler, before Ptaḥ, New Kingdom, in Berlin (West) Mus. 9427. Text, *Aeg. Inschr.* ii, p. 216. See *Ausf. Verz.* p. 133.







Pillar with Horus-name of Ramesses III. Text, BRUGSCH, *Recueil*, pl. iv [4].

Column, Hori  , Greatest of the Directors of craftsmen, etc., son of Ptaḥmosi  , before Ptaḥ and before Mut, probably Ramesside, in Cairo Mus. Temp. No. 20.1.25.4. Text, DARESSY in *Rec. Trav.* xi (1889), p. 81 [xxiv]. Names and titles, LIEBLEIN, *Dict.* No. 2042.

Titles of a Prophet of Icoḥ, Saḥurē, and Astarte, etc., with a Ramesside(?) cartouche. BRUGSCH, *Recueil*, pl. iv [3].

Two fragments of column-base of a Greatest of the Directors of craftsmen, etc., with cartouches of Sesonchis I, granite. DARESSY in *Rec. Trav.* xxii (1900), p. 143 [clxxvii].

Two blocks, Sesonchis III and Thekerti  , Greatest of the Directors of craftsmen, etc., before Sekhmet, and remains of similar scene before Ptaḥ and Sekhmet below, in Cairo Mus. JE 46915. Texts, id. in *Ann. Serv.* xx (1920), pp. 169-70 [5].

Remains of a goddess, with text mentioning Zeubastes(ankh       ), Chief of the harīm of Ptaḥ, etc., Dyn. XXII. Texts, id. ib. pp. 170-1 [6].

Block with dramatic mythological text, basalt, temp. Sabacon, in Brit. Mus. 498. SHARPE, *Eg. Inscr.* 1 Ser. 36-7 [top], 38; READ and BRYANT in *P.S.B.A.* xxiii (1901), pl. facing p. 160, cf. pp. 160-87; BREASTED in *Ä.Z.* xxxix (1901), Taf. i, ii, pp. 39-54; WILLIAMS rubbings, iv. 125-6; SEYFFARTH MSS. xii. 9768-72 (rubbings). Text, ERMAN, *Ein Denkmal memphitischer Theologie in Sitzungsber. Berlin*, xliii (1911), pp. 924-45, cf. 916-24, 946-7; SETHE, *Das „Denkmal memphitischer Theologie“* [etc.] in *Dramatische Texte* [etc.] (*Untersuchungen zur Geschichte und Altertumskunde Aegyptens*, 10), pp. 20-77, cf. 1-19, 78-80; line 2, DE ROUGÉ in *Mélanges archéologiques*, i (1873), pp. 20-1 (repr. in *Bibl. Ég.* xxvi, pp. 281-2); lines 3-48, JUNKER, *Die politische Lehre von Memphis in Abhandlungen der Preussischen Akademie der Wissenschaften*, Phil.-hist. Kl. (1941), No. 6, Taf. 1, pp. 7-77; parts, SANDMAN HOLMBERG, *The God Ptaḥ*, pp. 3*-5* [1-4], cf. 19-22 (from JUNKER). Cartouche and sketch, YORKE and LEAKE in *Transactions of the Royal Society of Literature of the United Kingdom*, i, Pt. i (1827), pl. x [26] (repr. as *Remarks on some Egyptian Monuments in England*). See JUNKER, *Die Götterlehre von Memphis (Schabaka-Inschrift) in Abhandlungen der Preussischen Akademie der Wissenschaften*, Phil.-hist. Kl. (1939), No. 23, pp. 3-77; DRIOTON in *Arts Asiatiques*, i (1954), pp. 96-7; SHARPE, *Eg. Antiq.* p. 89 [135*]; *Guide (Sculpture)*, pp. 220-1 [797]; *Guide, Eg. Collns.* (1964), pp. 61, 132; JUNGE in *Mitt. Kairo*, 29 (1973), pp. 195-204.

Fragments of the so-called 'Palermo Stone', with list of kings, etc., probably a Dyn. XXV copy of earlier document, basalt. GIUSTOLISI, *La 'Pietra di Palermo' e la cronologia dell'Antico Regno in Sicilia archeologica*, i [4] (1968), pp. 5-14 with figs.; ii [5] (1969), pp. 38-55 with figs.; ii [6] (1969), pp. 21-38. Texts of kings of Dynasties IV and V, SETHE, *Urk.* i. 235-49 [10 (150)]. See GODRON in *Chron. d'Ég.* xxvii (1952), pp. 17-22; HELCK in *Mitt. Kairo*, 26 (1970), pp. 83-5.

(a) Palermo, Museo Nazionale; PELLEGRINI, *Nota sopra un'iscrizione egizia* [etc.] in *Archivio Storico Siciliano*, n.s. xx (1896), Tav. i, ii, pp. 297-316; SCHÄFER, *Ein Bruchstück altägyptischer Annalen* (repr. from *Anhang zu den Abhandlungen der königl. Preuss. Akademie der Wissenschaften zu Berlin*, 1902), Taf. i, ii, pp. 1-41; NAVILLE in *Rec. Trav.* xxv (1903), pls. i, ii, pp. 64-81; GREGORIO, *Détails historiques et fac-simile en photographie de la 'Pierre de Palerme'*; DARBY, GHALIOUNGUI, and GRIVETTI, *Food: The Gift of Osiris*, i, figs. 1. 20-1. *Recto*, BREASTED, *History*, fig. 29; DONADONI in *Enciclopedia dell'Arte Antica Classica e Orientale*, ii, fig. 1216, p. 956; BRENTJES, *Von Schanidar bis Akkad*, pl. 90; ROUSSEAU-LIESENS, *Le Dossier secret du Nil et la Pierre de Palerme*, fig. 21; bottom part, PETRIE in HAMMERTON, *Universal History of the World*, i, fig. on p. 24. Names of estates of Neferirkarē, JACQUET-GORDON, *Domaines*, p. 151 [3R5]. Boats, HASSAN, *Giza*, vi [1], fig. 33, pp.

77-8. Palaeographical notes, CHEREZOV in *Festschrift Golenishchev (Drevniy Egipet. Sbornik statey.)*, pp. 262, cf. 261-72.

(b)-(d) Cairo Mus. JE 39734-5, 44859, said to have been found at el-Minya, see *Bibl.* iv. 133.

(e) Cairo Mus. JE 44860; GAUTHIER in MASPERO, *Le Musée Égyptien*, iii, pl. xxxi, pp. 29, 50-3; text, DARESSY in *B.I.F.A.O.* xii (1916), pp. 173-4.

(f) Cairo Mus.; DE CENIVAL in *Bull. Soc. fr. d'Ég.* No. 44 (Dec. 1965), pp. 13-17 with fig.

(g) London, Univ. Coll. 15508; STEWART, *Egyptian Stelae, Reliefs and Paintings from the Petrie Collection*, ii, pl. 3 [1], p. 6 [17]; *recto*, PETRIE in *Anc. Eg.* (1916), fig. on p. 119, cf. pp. 115, 120; *verso*, REEVES in *Göttinger Miscellen*, No. 32 (1979), pp. 47-51 with figs.

Jamb with Amasis wearing Red Crown, quartzite; text, DARESSY in *Ann. Serv.* xx (1920), p. 171 [7]. Companion-piece (White Crown) in Memphis (Tennessee), at entrance to Zoological Garden.

Names of Amasis, WILKINSON MSS. xiii. 32 [lower right]. Others, *L. D. Text*, i, on p. 204 [bottom].

Door-jamb of Thaiēsimu (companion-piece in Cambridge, Fitzwilliam Mus. E.5.1909, see *supra*), *recto*, Thaiēsimu and text, *verso*, Thaiēsimu embraced by goddess Semset , temp. Nektanebos I, in Brooklyn Mus. 56.152. BOTHMER, *Eg. Sculp.* pls. 70-1 [181-4], pp. 92-4 [74]; upper part of Thaiēsimu, BRECKENRIDGE, *Likeness. A Conceptual History of Ancient Portraiture*, figs. 32-3.

Names of Ptolemy I Soter. *L. D. Text*, i, on p. 204 [bottom].

Various.

Shrines.

Osiris and Min, dedicated by Siamün , Scribe of the Great Prison, son of Sery  and Sitip , Middle Kingdom, in Berlin Mus. 1624. Texts, *Aeg. Inschr.* i, pp. 151-2. See *Ausf. Verz.* p. 85.

Paḥ, with statuette, dedicated by Amenemōnet , Overseer of work on the pylon, cartouche of Ramesses II, quartz, in London, Univ. Coll. 14490.

Block, probably from shrine, Ramesses II offering(?), quartzite, in Munich, Staatl. Sammlung, Gl.124. *Äg. Sammlung* (1966), Abb. 59; *Staatl. Sammlung* (1976), p. 7 with fig.; head of King, MYŚLIWIEC, *Le Portrait royal dans le bas-relief du Nouvel Empire*, pl. cvi [235]. See WOLTERS and VON BISSING in *Münchner Jahrb.* (1913), p. 162 [533]; *Staatl. Sammlung* (1972), p. 5.

Termuthis, dedicated by Amenḥotp Huy , Servant (*sdm-cš*), Dyn. XIX, formerly in Descotil Colln. (quoted in error in *Bibl.* iv. 5). *Descr. Ant.* v, pl. 47 [6-8]; DENON, *Voyage dans la Basse et la Haute Égypte* (Paris, 1802), pl. 124 [4-6]; *Histoire scientifique et militaire de l'Expédition française en Égypte. Atlas*, pls. 269-70 [4-6].

Neith, dedicated by Amasis, granite, in Cairo Mus. CG 70010. ROEDER, *Naos (Cat. Caire)*, Taf. 8 [a], pp. 37-8; FECHHEIMER, *Plastik* (1914), on Taf. 98; (1923), on Taf. 108. See MASPERO, *Guide*, p. 212 [879].

Vessels.

Apophis II (‘Aḳenenrēc), fragment, granite, in Berlin Mus. 20366. LABIB, *Die Herrschaft der Hyksos in Ägypten und ihr Sturz*, Taf. 4, p. 29 [1]. Text, *Aeg. Inschr.* i, p. 269; HELCK, *Historisch-biographische Texte*, p. 56 [78].

Sethos I, faience, in Cairo Mus. JE 87784.

Chalice with gods, etc., in relief, inscribed for Sheshonk , son of (Osorkon II and) Keramama, incomplete, faience, in Berlin (West) Mus. 4563. WALLIS, *Egyptian Ceramic Art* (1900), fig. 38, p. 25; VON BISSING in *Nachr. Göttingen* (1941), Taf. ii [1], p. 119; TAIT in *J.E.A.* 49 (1963), pl. xxi [1], fig. 6, pp. 123-4 [xxxii]; KAISER, *Äg. Mus. Berlin* (1967), Abb. 814c, p. 80; KAYSER, *Ägyptisches Kunsthandwerk*, Abb. 119; *Meisterwerke altägyptischer Keramik*. Höhr-Grenzhausen, 16. Sept. bis 30. Nov. 1978, No. 349 with fig. Rim with text, TAIT in *Apollo*, lxxviii (1963), fig. 1, p. 200. See *Ausf. Verz.* p. 445.

Seven inscribed ointment-jars, faience, Late Period, formerly in Hilton Price and MacGregor Collns., now in Brooklyn Mus. 49.52.1-7. *Sotheby Sale Cat.* (MACGREGOR), June 26-July 6, 1922, pl. vii [290], p. 40; RIEFSTAHL, *Ancient Egyptian Glass and Glazes in the Brooklyn Museum* (1968), fig. 64, p. 108; HILTON PRICE in *P.S.B.A.* xxv (1903), pp. 326-7 with pl. (one); *Sotheby Sale Cat.* (HILTON PRICE), July 12-21, 1911, No. 713 with pl. xvii (one). Texts, HILTON PRICE, *A Catalogue of the Egyptian Antiquities* [etc.], ii (1908), p. 88 [4791].

Others.

Mirror of Ḥetep-ḥathor , Prophetess of Ḥathor, etc., bronze, late Old Kingdom or early Middle Kingdom, in Cairo Mus. CG 44075 (JE 30065). LILYQUIST, *Ancient Egyptian Mirrors* [etc.], fig. 11, p. 14 with note 142; BÉNÉDITE, *Miroirs (Cat. Caire)*, pp. 34-5 with fig. 8. See KAPLONY, *Beschriftete Kleinfunde in der Sammlung Georges Michailidis*, p. 25 [60, 1].

Weight of 270 debens of Taharqa, basalt, in Cairo Mus. CG 31652. WEIGALL, *Weights and Balances (Cat. Caire)*, pls. v, vi, p. 10. See MASPERO, *Guide*, p. 542 [5511].

Sistra of Amasis, faience. (a) Fragment, Reading, Ure Museum of Greek Archaeology, E.63.18. (b) Cairo Mus. CG 69334; HICKMANN, *Instruments de Musique (Cat. Caire)*, pl. lix [A, B], p. 93; id. *Ägypten*, Abb. 27 [right].

Faience fragment of King Senkamaniskeñ, in Cairo Mus. JE 41293. See DARESSY in *Ann. Serv.* x (1910), pp. 183-4.

Plaque mentioning Temple of Sethos I, faience, probably from foundation deposit, in New York, M.M.A. 17.194.2333. Text, BRUGSCH, *Thes.* 1223 [lower middle] (perhaps this); KITCHEN, *Ram. Inscr.* i. 124 [63, b]. See HAYES, *Scepter*, ii, p. 332.



Plaque of Ramesses III, faience, in Cairo Mus. JE 30082. See *Bull. Inst. Ég.* iii Sér. 3 (1892), p. 278.

Menat-fragment with cartouche of Psammetikhos II, faience, in Munich, Staatl. Sammlung, ÄS 5464.

Cylinder-seal with Horus-name Sekhemkhaꜣu (probably Shepseskharēꜣ), bronze, in Cairo Mus. JE 45495. Text, DARESSY in *Ann. Serv.* xv (1915), p. 94 [upper] (as JE 45041).

Clay sealing with cartouches of Amasis, in London, Univ. Coll. 17061. PETRIE, *Scarabs and Cylinders with Names*, pl. lviii [26.5.1].

EL-BADRASHEIN

Stela, To , Pastry-cook, with wife Iay  and others before Ptaḥ and Sekhmet, Dyn. XX, in Cairo Mus. JE 34208. MASPERO in GRÉBAUT, *Le Musée Égyptien*, i, pl. xlvi [right], p. 44.

PYRAMID-FIELD OF DAHSHÛR

Maps LXXIII, LXXIV

Plan, L. D. i. 34 [left]–35; DE MORGAN, *Dahchour*, i, plan at the beginning; ii, pl. i; id. *Carte de la Nécropole Memphite*, 1–4; FAKHRY, *Sneferu*, i, fig. 3 (adapted from DE MORGAN); and view, PERRING, *Pyramids*, iii, pl. xiii [bottom right and 15]; VYSE, *Operations*, iii, pl. facing p. 56. Plan of southern part, ARNOLD and STADELMANN in *Mitt. Kairo*, 31 (1975), Abb. 3 on p. 172. Views (mostly pyramids), FRITH, *Cairo, Sinai, Jerusalem* [etc.] (1860), 8th pl. = id. *Lower Egypt and Thebes*, 14th pl.; SÉE, *Naissance*, fig. on pp. 164–5 (with south Şaqqâra); YOYOTTE, *Treasures*, pl. on p. 18. MICHAŁOWSKI, *Pyramidy i mastaby*, pl. 27. Views of Pyramids, with plan and sections of interior of the Red Pyramid, POCOCKE, *A Description of the East*, i (1743), pl. xix facing p. 52. General accounts of de Morgan's excavations, DARESSY in *Bull. Inst. Ég.* iii Sér. 5 (1894), pp. 193–205; DE MORGAN in *Comptes rendus* (1895), pp. 169–79; id. in *Bull. Inst. Ég.* iii Sér. 7 (1897), pp. 131–3.

I. Pyramids

A AND B. PYRAMID-COMPLEXES OF SNEFRU 'PYRAMID-TOWN' BORCHARDT in *Ä.Z.* 42 (1905), p. 1, with position, Abb. 1.

Protective decree of Pepy I, year of 21st census, found near south-east corner of building, in Berlin (East) Mus. 17500. Id. ib. Taf. i, ii, pp. 2–11; WEILL, *Les Décrets Royaux* [etc.], pl. iii [1], pp. 43–52; MORET in *Journal Asiatique*, 11^e Sér. x (1917), pls. iv, v, pp. 387–427; GOEDICKE, *Königliche Dokumente aus dem Alten Reich*, Abb. 5, pp. 55–77. Text, SETHE, *Urk.* i. 209–13 [45 (136)]. See FAKHRY, *Sneferu*, i, p. 9; *Führer* (1961), p. 47.

A. NORTHERN COMPLEX

MARAGIOGLIO and RINALDI, *L'Architettura*, iii, pp. 124–39, with plans and sections, Tav. 18, 19.

CAUSEWAY.

See FAKHRY, *Sneferu*, i, p. 33.

PYRAMID. Lepsius, XLIX; Red Pyramid.

L. D. *Text*, i, pp. 206–7. Description, plans, and section, BURTON MSS. 25618, 9–10; 25620, 137. Plans, sections, and view, PERRING, *Pyramids*, iii, pl. xiv; VYSE, *Operations*, iii, pls. facing pp. 64, 65 [1st pl.], 58 [upper], cf. pp. 63–5. Vertical aerial view, GRINSELL, *Eg. Pyramids*, pl. xiii [a] facing p. 157; id. *Barrow, Pyramid and Tomb*, fig. 68. Views (some also showing interior), CAPART, *Memphis*, figs. 37–8; GILBERT, *Le Classicisme de l'architecture égyptienne*, fig. 3; VARILLE, *À propos des pyramides de Snefrou*, fig. 1, pp. 3–4; FAKHRY, *The Pyramids*, figs. 56, 58, pp. 95–7; id. in *The Egyptian Education Bureau London. The Bulletin*, No. 65 (May–June 1952), fig. on p. 31 [lower]; LAUER, *Mystère*, pl. ix [a]; VANDERSLEYEN, *Das Alte Ägypten*, Abb. 26 [b], 27 [a]; MENDELSSOHN, *The Riddle of the Pyramids*, pls. 29, 30; LECLANT and others, *Le temps des Pyramides*, figs. 87, 291; of interior, MENDELSSOHN in *Science Journal*, 4 [3] (1968), fig. on p. 51.

Masons' graffiti, on casing blocks on south side. L. D. ii. 1 [f, g], and *Text*, i, p. 206.

B. SOUTHERN COMPLEX

(perhaps also )

MARAGIOGLIO and RINALDI, *L'Architettura*, iii, pp. 54-123, with plans and sections, Tav. 8-17.

Plan, FAKHRY, *Sneferu*, i, fig. 5; id. in *Ann. Serv.* lii (1954), fig. 1 on p. 567; id. *The Pyramids*, fig. 43.

LOWER CAUSEWAY.

ARNOLD and STADELMANN in *Mitt. Kairo*, 31 (1975), p. 173 [2], with view, Taf. 111 [c].

LOWER TEMPLE.

Plan LXXIII (inset)

FAKHRY, *Sneferu*, i, pp. 27-9, 33, and 106-17 (by Ricke), with plans, reconstruction, and views, pls. iv [B], xlvi, xlvi, xlvi [A], xlix-li, figs. 60-2; id. ib. ii, Pt. 1, passim, with plans, reconstruction, and views, pls. i-iii [A], v-xi, figs. 1, 3-6; id. ib. ii, Pt. 2, passim; id. in *Ann. Serv.* lii (1954), pp. 569-93, with plan and views, pls. i [A], iv, v [A], vi, vii, fig. 3; RICKE in ib. pp. 610-16, 618-23, with plans and views, pls. iv-vi [a], Abb. 4, 6. Plan and reconstruction, FAKHRY, *The Pyramids*, fig. 44. Plan, reconstruction, and view, SMITH, *Art . . . Anc. Eg.* pl. 25 [A], figs. 12, 13, pp. 39-41. Views, LECLANT in *Orientalia*, n.s. 21 (1952), pls. xxx [5], xxxii [7], p. 237.

Fragments of two stelae with names of Snefru (originally one at each corner). FAKHRY, *Sneferu*, ii, Pt. 1, pls. iii [B], iv, pp. 1, 3; see id. in *Ann. Serv.* lii (1954), pp. 573-4 [A].

Central Hall and Court.

(1), (2)-(5), (6), (7) Base. Processions of nomes and estates, of Upper Egypt at (1)-(5), and of Lower Egypt at (6) and (7).

FAKHRY, *Sneferu*, ii, Pt. 1, pls. xii-xv, xxvii [C], figs. 9-34, cf. 8, pp. 17-58; id. in *Ann. Serv.* lii (1954), pls. v [B], viii-x, figs. 4-6, pp. 572, 573, 577-83. Parts, id. *The Pyramids*, figs. 42, 45; LECLANT in *Orientalia*, n.s. 21 (1952), pl. xxxi [6], p. 237; EDWARDS, *Pyramids* (1961), pl. 10 [b]; WOLF, *Kunst*, Abb. 172; SMITH, *Art . . . Anc. Eg.* pl. 26 [B]; HELCK, *Geschichte des Alten Ägypten*, Taf. i [3]; LAUER, *Mystère*, pl. 12 [a]. Names, JACQUET-GORDON, *Domaines*, pp. 125-37 [1R4], cf. figs. 1, 2.

Pillars.

Relief-fragments, the King alone or with gods (including Ptah, Min, and Seshet), in *heb-sed* ceremonies, and inspecting cattle-stalls of oryxes, Nile-gods bringing offerings, and fowling-scenes. FAKHRY, *Sneferu*, ii, Pt. 1, pls. xviii [A], xix [A, B left], xxiii-xxvii [A, B], xxix [A], cf. xxx-xxxii, figs. 35-118, pp. 59-110; id. in *Ann. Serv.* lii (1954), pls. xi [A], xii [B], xiv [A], xv [A], xvi, pp. 584-7 [1, 4, 8, 9, 11].

Six Chapels.

Relief-fragments, the King and names. Id. *Sneferu*, ii, Pt. 1, pls. xx-xxii, xxviii [B], xxix [B], cf. xxx-xxxii, figs. 119-37, pp. 111-22; id. in *Ann. Serv.* lii (1954), pls. xi [B], xiii, xiv [B], fig. 7, pp. 573, 585-7 [2, 5-7]. Two, RICKE in ib. pl. vi [b, c], Abb. 5, pp. 622-3.

Fragments of three statues of the King, originally attached to rear walls of niches of

Chapels. FAKHRY, *Sneferu*, ii, Pt. 2, pls. xxxiii–xxxvii, pp. 3–4 [A]; id. in *Ann. Serv.* lii (1954), pls. xviii, xix, pp. 575 [2], 588. Head and hand, id. *The Pyramids*, fig. 47.

Relief-fragments, original position uncertain.

The King, gods, and names. FAKHRY, *Sneferu*, ii, Pt. 1, frontispiece, pls. xvi, xvii, xviii [B], xix [B right], xxviii [A], xxix [C, D], cf. xxx–xxxii, figs. 138–282, pp. 125–65; id. in *Ann. Serv.* lii (1954), pls. xii [A], xv [B], xvii, pp. 585 [3], 587 [10], 588; heads of the King and lion-headed goddess, id. *The Pyramids*, fig. 46; SMITH, *Art . . . Anc. Eg.* pl. 26 [A], p. 41; DE RACHEWILTZ, *L'Arte*, Tav. 17, p. 30.

Statues

Old Kingdom.

‘Aḥauka , [King's son] of his body (probably of Snefru), Lector-priest, squatting, fragmentary. FAKHRY, *Sneferu*, ii, Pt. 2, pl. xlvi [A], p. 10 [2].

Duarē (tomb, see *infra*), temp. Saḥurē or later. Two fragmentary scribe-statues, id. ib. ii, Pt. 2, pls. xlvi [B, C], xlvii, figs. 285–6, pp. 10–11 [3, 4]; id. in *Ann. Serv.* lii (1954), pl. xxii [A] (one only), p. 589.

Nefermaet , Treasurer of the King of Lower Egypt, lower part of squatting statue, diorite. Id. *Sneferu*, ii, Pt. 2, fig. 287, p. 12 [5].



Wemtet[ka] , King's daughter of his body, squatting, Dyn. IV–V. Id. ib. ii, Pt. 2, pls. xliii, xlv, fig. 284, p. 9 [1]. Text, id. in *Ann. Serv.* lii (1954), p. 590 [top].



A Prophet of Snefru, Secretary, squatting with arms crossed on breast, headless, Dyn. V. Id. *Sneferu*, ii, Pt. 2, pl. xlv, p. 12 [6]; id. in *Ann. Serv.* lii (1954), pl. xxii [B] after p. 594.

Fragment of seated statue, with text mentioning Khufu, granite. Id. *Sneferu*, ii, Pt. 2, fig. 288, p. 13 [8].



Fragments of sandstone statuettes, one with text mentioning Snefru. Id. ib. ii, Pt. 2, fig. 288, pp. 12 [7], 13 [9].

Middle Kingdom.



Ameny-snefru , son of I'akhu , fragment. FAKHRY, *Sneferu*, ii, Pt. 2, fig. 307, p. 31 [43].

Faiḥezui , Inspector of prophets of the southern Pyramid of Snefru, etc., son of Snefruemsasi , (mother), block-statue, headless. Id. ib. ii, Pt. 2, pls. li, lii, figs. 289–90, pp. 15–16 [2]; see id. in *Ann. Serv.* lii (1954), p. 590; BOTHMER in *Brooklyn Museum Annual*, ii–iii (1960–2), p. 32 [xviii].

Iḳer , Guardian of the chamber, seated, fragment. FAKHRY, *Sneferu*, ii, Pt. 2, fig. 311, p. 32 [49].

Iti , Recipient from the ruler's table, son of Ameny-waḥ  and Kerḥi , statue-base with family in relief. Id. ib. ii, Pt. 2, pls. lxi, lxii, figs. 340–2, pp. 41–4 [1]; id. in *Ann. Serv.* lii (1954), pl. xxvi [B], p. 590.

Khentiuka , Chief lector-priest, fragment. Id. *Sneferu*, ii, Pt. 2, fig. 337, p. 38 [70].





Khent[iuka], Overseer of the cabinet, son of Si-ḥaṭḥor  and Sit-ḥaṭḥor , statue-base. Id. ib. ii, Pt. 2, pls. lxiii, lxiv, figs. 343–6, pp. 47–50 [4].



Meket , statue-base fragment, basalt. Id. ib. ii, Pt. 2, fig. 301, p. 28 [34].

Meket , fragmentary statue-base with family in relief. Texts, id. ib. ii, Pt. 2, pp. 45–6 [2].

Meketankh , Director of boats, and a Chief lector-priest of Snefru, seated, fragment of double-statuette, granite. Texts, id. ib. ii, Pt. 2, p. 21 [9].



Nakht-snefru , statuette-base and feet. Id. ib. ii, Pt. 2, pl. lx [B], fig. 299, p. 27 [30].

Neteruankh(?) , warb-priest, son of Hāthoriyti  (mother), and wife(?) Sepenmut , daughter of Meri , seated double-statuette, incomplete. Id. ib. ii, Pt. 2, pl. lvii [A], figs. 295-6, pp. 19-20 [7]; see BOTHMER in *Brooklyn Museum Annual*, ii-iii (1960-2), p. 33 [xx] (as two men).

Ptaḥpuwah  Renefso(n)b , . . . of the Pyramid of Snefru, Keeper of the chamber of the Great House, son of Sit-hāthor  (mother), statue-base with scenes in relief. FAKHRY, *Sneferu*, ii, Pt. 2, pls. lxvi [D], lxvii, figs. 350-3, pp. 53-5 [6].

Raḥotp , Steward, fragments. Id. ib. ii, Pt. 2, pl. lxxvii [A, left], figs. 303-6, p. 30 [40-2].

Renesankh , seated, much damaged. Id. ib. ii, Pt. 2, pl. lvi [A], fig. 294, p. 19 [5].

Si-hāthor , warb-priest [of Snefru], son of Mek(et) , headless block-statuette dedicated by son Min-snefru-sheri . Id. ib. ii, Pt. 2, pls. liii, liv, figs. 291-3, pp. 17-18 [3]; id. in *Ann. Serv.* lii (1954), pl. xxiv [A], p. 590; see BOTHMER in *Brooklyn Museum Annual*, ii-iii (1960-2), pp. 32-3 [xix].

Snefru-ḥirkhent , Lector-priest, statue-base with relatives in relief. FAKHRY, *Sneferu*, ii, Pt. 2, pls. lxv, lxvi [C], figs. 347-9, pp. 51-2 [5]; id. in *Ann. Serv.* lii (1954), pl. xxvi [A], p. 590.

Snefruḥotp , Chief lector-priest and Inspector of prophets in the Pyramid of Snefru, ebony. Id. *Sneferu*, ii, Pt. 2, pl. 1, p. 15 [1]; id. in *Ann. Serv.* lii (1954), pl. xxiii, p. 590.

. . . rer  . . . Snefru, son of Khent[iuka]. Fragments, granite; id. *Sneferu*, ii, Pt. 2, figs. 316, 318, pp. 34 [58], 36 [62].

A Scribe, Inspector of prophets, statuette-base fragment with name of Sesostris II, granite. Id. ib. ii, Pt. 2, fig. 339, p. 39 [72].

Two inscribed double-statuettes, man and woman, and two women, basalt and alabaster, fragments. See id. ib. ii, Pt. 2, p. 22 [10, 11].

Statue-bases, inscribed and some with relatives in relief, mostly fragments. Id. ib. ii, Pt. 2, figs. 354-84, pp. 46-7 [3], 55-61 [7-22].

Inscribed fragments, limestone, basalt, and granite. Id. ib. ii, Pt. 2, pl. lxxvi [C], figs. 297-8, 300, 302, 308-10, 312-15, 317, 319-36, 338, pp. 24 [20], 26 [25], 27-8 [31-2], 29 [35-6], 31-2 [44-8], 32-3 [50-1], 33-4 [53-7], 35 [59-61], 36 [63], 37-8 [64-9], 39 [71].

Uninscribed statues and fragments, limestone, basalt, alabaster, granite, diorite, and sandstone. Id. ib. ii, Pt. 2, pls. lv, lvi [B], lvii [B], lviii, lix, lx [A, C, D], pp. 19 [4, 6], 21 [8], 22-4 [12-19], 25 [21-4], 26-7 [26-9], 28 [33], 29 [37-9], 33 [52]; four, id. in *Ann. Serv.* lii (1954), pls. xxiv [B], xxv [A] and [B] (= No. 27), p. 590; one, LECLANT in *Orientalia*, n.s. 21 (1952), pl. xxxiii [8], p. 237.

Other finds

Old Kingdom and 1st Int. Period.

Stela of Neteraperef , King's son, Prophet of Snefru foremost of the *ḥt*-Pyramid, etc., with three estates at bottom, middle Dyn. V or later, found re-used, in Cairo Mus. JE 89290. FAKHRY, *Sneferu*, ii, Pt. 2, pls. xxxviii-xl, fig. 283, pp. 4-8 [B]; id. in *Ann. Serv.* lii (1954), pl. xxi, pp. 591-2; H. BR[UNNER] in *Archiv für Orientforschung*, xvi (1952-3), Abb.

20, pp. 162-3; FISCHER, *Dendera in the Third Millennium B.C.*, pl. i, pp. 8-9. Names of estates, JACQUET-GORDON, *Domaines*, pp. 434-5 [2D4], cf. figs. 187-8. Dating, SCHMITZ, *Untersuchungen zum Titel s3-njswt 'Königsohn'*, pp. 152-4 [VI].

Incomplete stela of woman Khons , 1st Int. Period. FAKHRY, *Sneferu*, ii, Pt. 2, pl. lxxiii [B], fig. 402, pp. 84-5 [3].

Clay sealings of Neferirkarē. See id. ib. ii, Pt. 2, pp. 13-14 [C].

Middle Kingdom.



Stela-fragment mentioning Ipi , Chief lector-priest. FAKHRY, *Sneferu*, ii, Pt. 2, fig. 409, p. 87 [11].



Family-stela of an Outline draughtsman, Lector-priest (name erased). Id. ib. ii, Pt. 2, pls. lxxii, lxxiii [A], pp. 79-83 [1].

Inscribed stela-fragments. Id. ib. ii, Pt. 2, pls. lxxvii [A, middle and right], figs. 401, 403-8, 412, pp. 83-4 [2], 85-7 [4-10], 88 [15].

Inscribed fragments. Id. ib. ii, Pt. 2, figs. 410-11, 413-26, pp. 87-8 [12-14], 88-90 [16].

Pedestal and offering-table of Snefru, Overseer of *warb*-priests of the temple, etc., son of Meket  (mother). Id. ib. ii, Pt. 2, pl. lxx, figs. 390-3, 427, pp. 69-74 [2], 91-2 [17]; see id. in *Ann. Serv.* lii (1954), p. 591 [11].



Offering-table of Sebkhotp Petety , Lector-priest, son of Renesankh  Hezert  (mother). Id. *Sneferu*, ii, Pt. 2, pl. lxxiv [A], fig. 428, p. 92 [18].

Offering-table of Meket , Director of recruits, son of Sitmeseh  (mother), and wife Sitamün. Id. ib. ii, Pt. 2, pl. lxxv [A], fig. 429, p. 93 [19].

Offering-table with remains of texts and scenes, unfinished. Id. ib. ii, Pt. 2, pl. lxxiv [B], p. 94 [22].

Naos of Snefru, *warb*-priest, son of Ipet , (mother), fragments. Id. ib. ii, Pt. 2, pl. lxxi, figs. 397-400, pp. 75-7 [5].

Naos-fragments with remains of scenes and texts. Id. ib. ii, Pt. 2, figs. 394-6, pp. 74-5 [3, 4].

Shrine for torch of Seshenu , Overseer of the Temple, Overseer of sculptors, son of Kerhi  (mother), with 'text of the torch', and relatives. Id. ib. ii, Pt. 2, pls. lxxviii, lxxix, figs. 385-9, pp. 63-9 [1].

Trial-piece, *recto*, cartouche of Amenemhēt II, *verso*, hand holding pigeons, and foxes mating. See id. ib. ii, Pt. 2, p. 99 [16].

Fragment of limestone lid of box for documents concerning appointment of temple officials, years 1, 5, 11, 15. Id. ib. ii, Pt. 2, pl. lxxvi [B], fig. 430, p. 96 [6].

Two fragmentary inscribed pestles, sandstone and basalt. Texts, id. ib. ii, Pt. 2, p. 97 [9, 10].

Cylinder seal with Horus-name of Snefru, faience. See id. ib. ii, Pt. 2, p. 95 [1].

UPPER CAUSEWAY.



FAKHRY, *Sneferu*, i, pp. 36-9, with views, pls. iii, iv [A], and RICKE in ib. pp. 105-6, with plans and section, fig. 59; RICKE in *Ann. Serv.* lii (1954), pp. 609-10, with plans and views, pls. ii [b], iii, Abb. 3; JÉQUIER, *Douze ans*, pp. 11-12, with plan, fig. 2.

UPPER TEMPLE.

FAKHRY, *Sneferu*, i, pp. 75-87, 98-104 (latter by Ricke), with plans, sections, views, and reconstruction, pls. xxvii-xxxi and frontispiece, figs. 4, 42-5, 57-8; id. in *Ann. Serv.* li (1951), pp. 513-21, with plan and views, pl. ii [B], figs. 1, 2; lii (1954), pp. 564-5, and RICKE in ib.

pp. 605-8, with plans and views, pls. i, ii [a], Abb. 1, 2. Plan, FAKHRY, *The Pyramids*, fig. 48; SMITH, *Art . . . Anc. Eg.* fig. 11, p. 39. View, LECLANT in *Orientalia*, N.S. 21 (1952), pl. xxix [4], p. 237; HELCK, *Geschichte des Alten Ägypten*, Taf. i [2].

Fragments of two stelae with names of the King. FAKHRY, *Sneferu*, i, figs. 38-41, p. 75.



Two altars, both of Snefrusonb-nezes , Great *warb*-priest, Regulator of a phyle, son of Ip  (mother), and probably his father Snefru(sonb), same titles, Dyn. XII. Id. *ib.* i, pls. xxxii-xxxvi, figs. 47-52, pp. 84-7; id. in *Ann. Serv.* li (1951), pls. iii, iv, figs. 3-5, pp. 518-21; one, LECLANT, *op. cit.* pl. xxxiii [9], p. 237.

PYRAMID. Lepsius, LVI. Blunted, Bent, False, or Rhomboidal Pyramid.

L. *D. Text*, i, p. 208; BURTON MSS. 25618, 11-12, with plan, 25620, 138; PETRIE, *A Season in Egypt*, pp. 26-32, with plans and section, pl. xxiv; FAKHRY, *Sneferu*, i, pp. 25-6, 32, 40-59, 65-73 (by MUSTAPHA), with plans, sections, views, etc., pls. ii, v, vi, viii-xv, xxvi, figs. 16-24, 33-6; ii, Pt. 2, p. 102 with fig. (by RINALDI); id. in *Ann. Serv.* li (1951), pp. 509-13, with views, pls. i, ii [A]; id. *The Pyramids*, pp. 88-94, with plan, sections, views, etc., figs. 50-5; MUSTAPHA in *Ann. Serv.* liii (1954), p. 599, with plans, sections, views, etc., pls. 2-6, fig. 4. Plan, sections, and view, PERRING, *Pyramids*, iii, pls. xv [1, 2, 4-6, 9], xvi; VYSE, *Operations*, iii, pls. facing pp. 65 [2nd pl.], 66, 67, 68, 69 [1-3].

Vertical aerial view, GRINSELL, *Eg. Pyramids*, pl. xiii [b] facing p. 157; id. *Barrow, Pyramid and Tomb*, fig. 67. Aerial view, SAMIVEL and AUDRAIN, *The Glory of Egypt*, pl. 19. Views¹ (some including interior), FRITH, *Cairo, Sinai, Jerusalem* [etc.] (1860), 20th pl.; CAPART, *Memphis*, fig. 33; id. *L'Art ég.* i, pl. 10; SCHÄFER and ANDRAE, *Kunst* (1925), 201 [lower]; (1930 and 1942), 208 [lower]; PIJOAN, *History of Art*, i, fig. 73; id. *Summa Artis*, iii (1945), fig. 93; BORCHARDT and RICKE, *Egypt*, pl. 96; STEINDORFF, *Kunst*, 110; VARILLE, *À propos des pyramides de Snefru*, fig. 2, pp. 4-8; HAMANN, *Ag. Kunst*, Abb. 117; DE WIT, *Oud-Egyptische Kunst*, fig. 10 facing p. 24; DESROCHES-NOBLECOURT, *L'Art ég.* fig. 7; GARNONS WILLIAMS in *I.L.N.* March 22, 1947, fig. 1 on p. 303; FAKHRY in *The Egyptian Education Bureau London. The Bulletin*, No. 65 (May-June 1952), fig. on p. 31 [upper], cf. pp. 28, 33; SPIEGEL, *Hochkultur*, Taf. 6 [b]; COTTRELL, *Egypt*, fig. 78; BAROCAS, *Egypt*, fig. 3; *Great Museums*, fig. on p. 192 [20]; MENDELSSOHN, *The Riddle of the Pyramids*, pls. vii, 25-7; id. in *Science Journal*, 4 [3] (1968), fig. on p. 50 [upper right]; MICHAŁOWSKI, *Piramidy i mastaby*, pls. 23-4; SOGA, *The Nile*, figs. on pp. 50 [upper], 60; MONTET, *Lives of the Pharaohs*, fig. on p. 19; DAVID, *The Egyptian Kingdoms*, fig. on p. 37 [top]; LAUER, *Mystère*, pls. viii, 11 [b]; VANDERSLEYEN, *Das Alte Ägypten*, Abb. 26 [a]; LECLANT and others, *Le temps des Pyramides*, figs. 85-6, 289-90; HAY MSS. 29812, 92-4; of interior, GARNONS WILLIAMS in *I.L.N.* March 22, 1947, figs. 3-10 on pp. 304-5; EDWARDS, *Pyramids* (1961), pl. 10 [a], 11 [a]; SMITH, *Art . . . Anc. Eg.* pl. 25 [B], p. 39; RUFFLE, *Heritage of the Pharaohs*, fig. 133.

Masons' graffiti and marks, including two with names of Snefru (one from Upper Burial Chamber, the other from north-east corner of Pyramid). FAKHRY, *Sneferu*, i, pls. xvi-xx, figs. 25-9, p. 59; name of Snefru at north-east corner, GARNONS WILLIAMS in *I.L.N.* April 5, 1947, figs. 2, cf. 1, on p. 344; see VARILLE, *À propos des pyramides de Snefru*, pp. 6-7.

Two visitors' graffiti, of Pairptah , God's father of Ptah, son of Penamün , and of Neferher , *warb*-priest, Late Period, in Northern Entrance Passage. FAKHRY, *Sneferu*, i, figs. 14, 15, pp. 46-7; PERRING, *Pyramids*, iii, pl. xv [7, 8]; VYSE, *Operations*, iii,

¹ Selected references.

pl. facing p. 69 [4], cf. p. 76; MARIETTE, *Mastabas*, p. 576; PETRIE, *A Season in Egypt*, pl. xix [695-6]; id. in SAYCE MSS. 14d; WILKINSON MSS. v. 46 [lower]; HAY MSS. 29833, 79 [right top]; BURTON MSS. 25618, 13, 16, and 25620, 133, 134 (squeezes).

SUBSIDIARY PYRAMID. Lepsius, LVII.

FAKHRY, *Sneferu*, i, pp. 89-96, 104-5 (latter by RICKE), with plans, sections, and views, pls. xxxvii-xxxix, xlv, xlv, figs. 55-6; id. in *Ann. Serv.* lii (1954), pp. 565-8, with views, pls. ii [A], cf. i [B]. Section, PERRING, *Pyramids*, iii, pl. xv [3]; MARIETTE, *Mastabas*, p. 582, cf. pp. 579-82. Views, GARNONS WILLIAMS in *I.L.N.* April 5, 1947, figs. 4, 5 on p. 344. Measurements, VYSE, *Operations*, iii, p. 70.

Masons' graffiti. FAKHRY, *Sneferu*, i, pls. xxi-xxiv, p. 94.

Two stelae with names of the King (lower part of the northern only, the southern in Cairo Mus. JE 89289). FAKHRY, *Sneferu*, i, pls. xl-xliii, figs. 53-4, pp. 89-90, 104 (last by Ricke). Cairo JE 89289, FAKHRY in *Ann. Serv.* lii (1954), pls. ii [B], iii, p. 566; EDWARDS, *Pyramids* (1961), pl. 11 [b]; King seated, FAKHRY, *The Pyramids*, fig. 49; MENDELSSOHN, *The Riddle of the Pyramids*, pl. 47.

C. PYRAMID-COMPLEX OF SESOSTRIS III

Plan LXXV

CAUSEWAY.

JÉQUIER in *Ann. Serv.* xxv (1925), pp. 56-61, with plan and section, fig. 1; id. *Douze ans*, pp. 134-8, with view, fig. 38.

Block, two registers of Nubian archers, in Cairo Mus. JE 51978; id. *ib.* fig. 39, p. 136; MÜLLER, *Äg. Kunst*, Abb. 71; FISCHER in *Kush*, ix (1961), pl. xiv [c], pp. 72-3; see GUNN in *Ann. Serv.* xxix (1929), p. 93. Another two blocks, in Cairo Mus. JE 51958 (stolen), 51959. Sea-going boats, see JÉQUIER in *Ann. Serv.* xxv (1925), p. 59; id. *Douze ans*, pp. 136-7.

UPPER ENCLOSURE

Plan, DE MORGAN, *Dahchour*, i, fig. 105 between pp. 48-9; ii, pl. xv; id. in *Le Monde Moderne*, Jan. 1895, p. 71.

MORTUARY TEMPLE.

Reliefs. Names of the King, id. *Dahchour*, i, figs. 111-12, p. 51; another, fig. on p. 47 [top], cf. p. 165. Fragments of cartouche, offering-list, offering-bringers, offerings, butchers, priests, etc., PERRING, *Pyramids*, iii, pl. xiii [4-12]; VYSE, *Operations*, iii, pls. facing pp. 60 and 63 [3-10], cf. pp. 72-6 (BIRCH) (repr. DE MORGAN, *Dahchour*, i, fig. 1 [lower], p. 3).

PYRAMID. Lepsius, XLVII.

DE MORGAN, *Dahchour*, i, pp. 47-50, 84-5, with sections, etc., figs. 106-9, and views, pls. ii, iii, xii-xiv; ii, figs. 132-6, cf. 131 (sarcophagus), pp. 87-97. View, in *Le Monde Moderne*, Jan. 1895, fig. on p. 68. Section and view, PERRING, *Pyramids*, iii, pl. xiii [1, 14]; VYSE, *Operations*, iii, on pls. facing pp. 60, 58 [lower], cf. pp. 57-63. Description, BURTON MSS. 25618, 17.

Visitors' graffiti, hieratic, probably Ramesside (one [= fig. 183] in Cairo Mus. CG 25377), DE MORGAN, *Dahchour*, i, figs. 183-6, p. 77; transcription of Cairo CG 25377, DARESSY,

Ostraca (Cat. Caire), p. 98. Another two, PERRING, op. cit. iii, pl. xiii [2, 3]; VYSE, op. cit. iii, pl. facing p. 60 [1, 2] (repr. DE MORGAN, *Dahchour*, i, fig. 1 [upper]).

NORTH GALLERIES AND MASTABAS OF PRINCESSES.

DE MORGAN, *Dahchour*, i, pp. 53-75, with plans and sections, figs. 119-21, 124, 128, 163, cf. pls. xv-xxv (jewellery); id. in *Comptes rendus* (1894), pp. 113-17, with plan on p. 115. View, id. in *Le Monde Moderne*, Jan. 1895, fig. on p. 72.

Two inscribed pottery jars, Middle Kingdom. Id. *Dahchour*, i, figs. 164-5, p. 73.



Upper gallery with four mastabas above.

Fragments with titles of a queen, id. ib. i, fig. 182, p. 77.

I (from west). Fragments of statue of Nesumontu , Chief steward, etc., diorite, Dyn. XII. Text, id. ib. i, fig. 116, p. 53.

II. Sarcophagus of Nefert-henut , King's wife (of Sesostris III), etc. Id. ib. i, figs. 117-18, p. 53.

Lower gallery.

Sarcophagi of Ment  and Sent-senbetes , both King's daughters (of Sesostris III). Texts, id. ib. i, figs. 122-3, p. 56.



Two fragmentary canopic-jars of Ment, alabaster, in Cairo Mus. CG 4005-6. Texts, id. ib. i, fig. 126, p. 57; REISNER, *Canopics*, pp. 3-4; id. in *A.Z.* xxxvii (1899), pp. 62 [8], cf. 64 [1, a].

Granite chest, uninscribed, in Cairo Mus. CG 4046, originally containing inscribed gold-leaf covered wooden canopic-box of a princess. Text of box, DE MORGAN, *Dahchour*, i, fig. 125, p. 57. Cairo CG 4046, REISNER, *Canopics*, pl. lxxx, pp. 25-7; see MASPERO, *Guide*, p. 110 [307].

1st 'cache' of jewellery. With scarab of Sit-hathor , King's daughter (of Sesostris II).

Pectoral¹ of Sesostris II, gold and coloured stones, in Cairo Mus. CG 52001. DE MORGAN, *Dahchour*, i, p. 60 [1] with pls. xv [1], xvi [1], xxi [upper right]; VERNIER, *Bijoux et orfèvreries (Cat. Caire)*, pl. i, pp. 1-4; id. *La Bijouterie et la joaillerie égyptiennes*, pl. ix [1, 3], p. 115; MÖLLER, *Die Metallkunst der alten Ägypter*, Taf. 7; BOREUX, *L'Art ég.* pl. lxii [a]; WILKINSON (A.), *Ancient Egyptian Jewellery*, pl. xv, p. 85. *Recto*, DE MORGAN in *Le Monde Moderne*, Jan. 1895, fig. on p. 73 [lower]; BORCHARDT, *Works of Art*, pl. 41 [top]; WEIGALL, *Anc. Eg. . . . Art*, 92 [upper]; SCHÄFER and ANDRAE, *Kunst* (1925), 296 [upper left]; (1930 and 1942), 309 [upper left]; WOLF in BOSSERT, *Geschichte des Kunstgewerbes*, iv, fig. 2 on p. 115; MITRY, *Illus. Cat.* No. 3983; CAPART, *L'Art ég.* iv, pl. 634 [lower]; *Encycl. phot. Caire*, pl. 73; SMITH, *Art . . . Anc. Eg.* pl. 80 [A, top], p. 111; PIRENNE, *Hist. civ.* ii, pl. 17 facing p. 64; PIJOÁN, *Summa Artis*, iii (1945), fig. 296 [upper left]; LEIBOVITCH, *Anc. Eg.* fig. 118; LANGE and HIRMER, *Ägypten. Architektur* (1967), pl. xiv [top]; Amsterdam. *5000 jaar*, fig. 20 [48]; Brussels. *5000 ans*, fig. 17, p. 24 [26]; MICHALOWSKI, *Art*, fig. 791; ALDRED, *Jewels of the Pharaohs*, pl. 33; LECLANT and others, *Le temps des Pyramides*, figs. 220, 232. *Verso*, PETRIE, *Arts and Crafts*, fig. 97 facing p. 88; WARD (J.), *The Sacred Beetle*, fig. on p. 34 [lower]; id. in *P.S.B.A.* xxii (1900), fig. on p. 310; STEINDORFF, *Kunst*, 292 [upper right]. See MASPERO, *Guide*, p. 424 [3983]; EVERS, *Staat aus dem Stein*, ii, pp. 66-8 [447 (7), 454]; FEUCHT-PUTZ, *Die königlichen Pektoreale*, p. 161 [1], cf. Taf. iv.

¹ Selected references.

2nd 'cache' of jewellery. With scarabs of Mereret  (or Meryt )¹, King's daughter (of Sesostriis III and probably Khnemt-neferhet ).

Pectoral¹ of Sesostriis III, gold and coloured stones, in Cairo Mus. CG 52002. DE MORGAN, *Dahchour*, i, p. 64 [1] with pls. xix [1], xxi [upper left]; VERNIER, *Bijoux et orfèveries (Cat. Caire)*, pl. i, p. 4; id. *La Bijouterie et la joaillerie égyptiennes*, pl. ix [4, 5], pp. 93, 115; WEIGALL, *Anc. Eg. . . . Art*, 93 [upper]; MÖLLER, *Die Metallkunst der alten Ägypter*, Taf. 8; CAPART, *L'Art ég.* iv, pl. 635; id. *L'Art ég.* (1909), pl. 50; BOREUX, *L'Art ég.* pl. lxii [b]; WILKINSON (A.), *Ancient Egyptian Jewellery*, pl. xvii and col. pl. ii, pp. 85-6. *Recto*, DE MORGAN in *Le Monde Moderne*, Jan. 1895, fig. on p. 73 [upper]; MASPERO, *Guide*, fig. 121, pp. 423-4 [3970]; SCHÄFER and ANDRAE, *Kunst* (1925), 296 [upper right]; (1930 and 1942), 309 [upper right]; BORCHARDT, *Works of Art*, pl. 41 [bottom]; PIJOÁN, *Summa Artis*, iii (1945), fig. 296 [upper right]; LANGE and HIRMER, *Ägypten. Architektur* (1967), pl. xiv [middle]; SMITH, *Art . . . Anc. Eg.* pl. 80 [A, bottom], p. 111; KAYSER, *Ägyptisches Kunsthandwerk*, col. pl. xiii facing p. 224; MÜLLER, *Äg. Kunst*, Abb. 76 [upper]; *Great Museums*, pl. 57; YOYOTTE, *Treasures*, pl. on p. 55 [upper]; ALDRED, *Jewels of the Pharaohs*, pl. 41; VILÍMKOVÁ, *Chefs-d'œuvre*, pl. 9; VANDERSLEYEN, *Das Alte Ägypten*, Abb. lvi [a]; WESTENDORF, *Das Alte Ägypten*, fig. on p. 97; DEMISCH, *Die Sphinx*, Abb. 65; LECLANT and others, *Le temps des Pyramides*, fig. 234. *Verso*, PETRIE, *Arts and Crafts*, fig. 98 facing p. 88; WARD (J.), *The Sacred Beetle*, fig. on p. 117; id. in *P.S.B.A.* xxii (1900), fig. on p. 311; STEINDORFF, *Kunst*, 292 [upper left]; ALDRED, *M.K. Art*, pl. 72. See EVERS, *Staat aus dem Stein*, ii, pp. 68-70 [458-66], cf. i, Abb. 20 on p. 79 (from VERNIER); FEUCHT-PUTZ, *Die königlichen Pektoreale*, p. 163 [4], cf. Taf. iv.

Pectoral¹ of Amenemhêt III, gold, coloured stones, and faience(?), in Cairo Mus. CG 52003. DE MORGAN, *Dahchour*, i, p. 64 [2] with pls. xx [2], xxi [lower]; VERNIER, *Bijoux et orfèveries (Cat. Caire)*, pl. ii, p. 5; id. *La Bijouterie et la joaillerie égyptiennes*, pl. xi [4, 5], pp. 93, 115; WEIGALL, *Anc. Eg. . . . Art*, 105; ALDRED, *Jewels of the Pharaohs*, pls. 42, 76; WILKINSON (A.), *Ancient Egyptian Jewellery*, pl. xviii, pp. 86-7. *Recto*, DE MORGAN in *Le Monde Moderne*, Jan. 1895, fig. on p. 74 [upper]; MITRY, *Illus. Cat. No. 3971; Encycl. phot. Caire*, pl. 74; SCHÄFER and ANDRAE, *Kunst* (1925), 296 [lower right]; (1930 and 1942), 309 [lower right]; ROSENBERG, *Ägyptische Einlage in Gold und Silber*, figs. 12-14, pp. 5-7; id. *Geschichte der Goldschmiedekunst. Zellenschmelz*, figs. 4, 5, pp. 5, 6; KISA, *Das Glas im Altertume*, i, Abb. 26, p. 147; PIJOÁN, *Summa Artis*, iii (1945), fig. 296 [lower right]; WOLDE-RING, *Götter*, Taf. xv; WOLF in BOSSERT, *Geschichte des Kunstgewerbes*, iv, fig. 3 on p. 115; RIESTERER, *Kunstschätze . . . Kairo*, pl. 22 (as el-Lâhûn); MICHALOWSKI, *Art*, fig. 793; LANGE and HIRMER, *Ägypten. Architektur* (1967), pl. xiv [bottom]; MÜLLER, *Äg. Kunst*, Abb. 76 [lower]; *Great Museums*, pl. 56; YOYOTTE, *Treasures*, pl. on p. 55 [lower]; VILÍMKOVÁ, *Chefs-d'œuvre*, pl. 10; WILDUNG and GRIMM, *Götter, Pharaonen* (1978), No. 19. *Verso*, ALDRED, *M.K. Art*, pl. 73; KAYSER, *Ägyptisches Kunsthandwerk*, Abb. 153. See MASPERO, *Guide*, p. 424 [3971]; EVERS, *Staat aus dem Stein*, ii, pp. 70-1 [467-71]; FEUCHT-PUTZ, *Die königlichen Pektoreale*, pp. 163-4 [5], cf. Taf. iv.

Two bracelet slides of Amenemhêt III, gold and coloured stones, in Cairo Mus. CG 52026-7. DE MORGAN, *Dahchour*, i, p. 66 [15, 16] with pl. xx; ALDRED, *Jewels of the Pharaohs*, on pl. 46. See VERNIER, *Bijoux et orfèveries (Cat. Caire)*, p. 21; MASPERO, *Guide*, p. 423 [3968-9].

¹ Selected references.

Two shafts north of Mastaba I. D and F of de Morgan.

Two uninscribed alabaster sarcophagi, Old Kingdom, in Cairo Mus. CG 28102-3. LACAU, *Sarcophages*, pl. xiv (CG 28102), p. 80. See DE MORGAN, *Dahchour*, i, pp. 75-6; FIRTH [etc.], *Step Pyr.* i, p. 42 note; LAUER in *Ann. Serv.* xxxiii (1933), pp. 165-6; DONADONI ROVERI, *Sarcofagi egizi*, pp. 110-11 [B 6, 7]; MASPERO, *Guide*, pp. 11 [30], 28 [40].

Fragment with names of Sesostris III, from shaft D. DE MORGAN, *Dahchour*, i, fig. 127, pp. 57, 165; id. in *Le Monde Moderne*, Jan. 1895, fig. on p. 70.

SOUTH MASTABAS.

Relief-fragments, perhaps from here. Offering-lists, id. *Dahchour*, i, figs. 178-80, p. 76.

SOUTH-EAST COURT.

Visitors' graffiti, hieratic, Ramesside (column-fragments with some [= figs. 190-1, 194] in Cairo Mus. CG 25378-9). Id. ib. i, figs. 190-5, p. 78; transcription of Cairo CG 25378-9, DARESSY, *Ostraca (Cat. Caire)*, pp. 98-100.

Fragment of votive stela, deceased before statue of deified Sesostris I, New Kingdom. DE MORGAN, *Dahchour*, i, fig. 83bis on p. 42, cf. p. 165.

Shaft H. Paneit  Head of police, son of Pedusiri and Taimhōtep, Ptolemaic.

Names and titles, id. ib. i, fig. 200, p. 78.

Lower part of statuette of Senbebu(?) , Door-keeper of the temple, Middle Kingdom, intrusive. Id. ib. i, fig. 175bis, p. 165.

BOAT-BURIALS. Some in a brick-built vaulted chamber.

DE MORGAN, *Dahchour*, i, pp. 81-3, with plans, sections, and views, including wooden boats and sled, pls. xxviii-xxx, figs. 201-4. View, WARD (J.), *Pyramids and Progress*, figs. on p. 56 [upper, cf. lower right].



Boats. (a) and (b) Two (also fragment of rudder and sled), in Cairo Mus. CG 4925-6 (with CG 4927-8); see REISNER, *Models of Ships and Boats (Cat. Caire)*, pp. 83-9, with details; MASPERO, *Guide*, p. 7 [6, 9] (as Sesostris II); view of one boat, CLARKE and ENGELBACH, *Ancient Egyptian Masonry*, fig. 34; MITRY, *Illus. Cat.* No. 6; hawk-heads on rudder-posts, DAVIES MSS. 2.14. (c) Chicago, Field Mus. Nat. Hist. A.31760; BREASTED, *History*, fig. 82; LANDSTRÖM, *Ships of the Pharaohs*, figs. 274, cf. 275, 277-82, pp. 90-3. (d) Pittsburgh, Museum of Art, Carnegie Institute, 1842.

D. PYRAMID-COMPLEX OF AMENEMHĒT II

Plan LXXIV (inset)



UPPER ENCLOSURE

DE MORGAN, *Dahchour*, ii, pp. 29-39, with plans and sections, pl. ii, figs. 63, 77-83.



Inscribed temple relief-fragments with names of Amenemhēt II (one = fig. 93, formerly in Paris, Mus. Guimet, 4849, now in Louvre, E.22348), and of intrusive private monuments of Si-ipy , Regulator of a phyle, son of 'Amet  (mother), Senbebu , Great *wab*-priest of Ptah, and others, Middle Kingdom, from eastern part. Id. ib. ii, figs. 86-94, pp. 37-9.

PYRAMID. Lepsius, LI, White Pyramid.

Masons' graffiti and marks. Id. *Dahchour*, ii, figs. 64-76, 85, pp. 31, 36.

Fragment of statue of Sebkhemhêt , Chief steward, son of Sitwerut  (mother), diorite, Middle Kingdom, intrusive. Text, id. ib. ii, fig. 84, p. 36.

TOMBS IN WEST PART OF ENCLOSURE

ITI  and KHNEMT , King's daughters (presumably of Amenemhêt II).¹



DE MORGAN, *Dahchour*, ii, pp. 40-68, with plan, section, and view, figs. 96-8. Date, see WILLIAMS (B.) in *Serapis*, 3 (1975-6), pp. 41-55 (as Dyn. XIII).

Masons' graffiti. DE MORGAN, op. cit. ii, figs. 99-104, p. 44.



Wooden rectangular coffins. Iti, id. ib. ii, figs. 105, 109, pp. 46-8 (texts). Khnemt; texts, id. ib. ii, pp. 57-8.

Canopic chest of Khnemt, wood(?). Texts, id. ib. ii, p. 68.

Two sets of alabaster ointment jars, eight each, and another jar, in Cairo Mus. CG 18643-50 (with wooden box, CG 18642), 18652-9 (box, CG 18651), 18661. VON BISSING, *Steingefässe (Cat. Caire)*, pp. 136-9, 140 with Taf. A. Texts, DE MORGAN, *Dahchour*, ii, figs. 108, 110, pp. 49, 56.

Lower part of false-door of Amenemhêtankh  , King's son (probably of Amenemhêt II), etc., re-used in offering-chamber of Khnemt, in Cairo Mus. CG 1488 (panel, see *infra*). Id. ib. ii, fig. 111, p. 68; text, BORCHARDT, *Denkmäler*, i, pp. 189-90.





AMENHOTP, Overseer of the seal, etc., temp. Amenemhêt II, and KEMINUB

 , King's wife (of Amenemhêt II).

DE MORGAN, *Dahchour*, ii, pp. 68-71, with plan, fig. 112.

Fragments of inscribed wooden coffin of Amenhotp. Id. ib. ii, figs. 113-15, p. 70.

Fragments of wooden coffin with Chapter 30B of Book of the Dead and canopic-chest of Keminub. Id. ib. ii, figs. 116-17, p. 70.

ITIWERT²  , King's daughter (presumably of Amenemhêt II), and SIT-HAT(HOR)-MER(T)  , temp. Amenemhêt II.

DE MORGAN, *Dahchour*, ii, pp. 71-7, with plan and section, figs. 118-19.

Masons' graffiti. Id. ib. ii, figs. 120-2, p. 71.

Wooden coffins. Itiwert; texts, id. ib. ii, pp. 73-4. Sit-hat(hor)-mer(t), in Cairo Mus. CG 28101; texts, id. ib. ii, pp. 75-6; LACAU, *Sarcophages*, ii, pp. 77-9, cf. 80; Coffin-texts, DE BUCK, *Coffin Texts*, vii, Da 1 C.

Canopic-chests, wood(?). Iti(wert); text, DE MORGAN, op. cit. ii, p. 74. Sit-hat(hor)-mer(t); text, id. ib. ii, p. 76 [lower].

Two sets of alabaster ointment jars, in Cairo Mus. CG 18662-9 (probably these), 18670-7. Texts, VON BISSING, *Steingefässe (Cat. Caire)*, pp. 140-3; of jars of Sit-hat(hor)-mer(t), DE MORGAN, op. cit. ii, fig. 126, p. 76.

Statue of swan, wood, from offering-chamber of Itiwert, in Cairo Mus. Temp. No. 24.6.25.4. Id. ib. ii, fig. 123, p. 74; VANDIER D'ABBADIE in *Rev. d'Ég.* 25 (1973), pl. 2, pp. 38-41 with fig. 4.

¹ Uninscribed jewellery of Iti and Khnemt is in Cairo Museum.

² Jewellery in Cairo Museum.

E. PYRAMID-ENCLOSURE PROBABLY OF DYNASTY XIII

Lepsius, LIV

FAKHRY, *The Pyramids*, p. 217; ARNOLD and STADELMANN in *Mitt. Kairo*, 31 (1975), p. 174 [4], with view, Taf. 112 [b].

F. PYRAMID-COMPLEX OF AMENEMHĒT III

ARNOLD in *Archiv für Orientforschung*, xxv (1974-7), pp. 321-2 [2-5], cf. Abb. 8; id. and STADELMANN in *Mitt. Kairo*, 31 (1975), pp. 170-3 [1], cf. Taf. 110 [b].

VALLEY TEMPLE.

ARNOLD and STADELMANN in *Mitt. Kairo*, 33 (1977), pp. 15-17 [2], with plan, Abb. 1, and views, Taf. 1 [b], 2 [a].

Limestone model of interior of a pyramid, late Dyn. XII or Dyn. XIII. Id. ib. Taf. 3 [b], p. 16.

CAUSEWAY.

DE MORGAN, *Dahchour*, ii, pp. 99-100, with sections, figs. 143-4.

UPPER ENCLOSURE

Plan, DE MORGAN, *Dahchour*, i, fig. 205; ii, pls. xvii, cf. xvi (as Amenemhēt II); ARNOLD and STADELMANN in *Mitt. Kairo*, 31 (1975), Abb. 1 facing p. 170.

MORTUARY TEMPLE.

DE MORGAN, *Dahchour*, i, pp. 116-17; ii, p. 98.

Fragment of text, id. ib. i, fig. 271, p. 117; ii, fig. 142, p. 98; ARNOLD and STADELMANN in *Mitt. Kairo*, 31 (1975), Taf. 111 [b], p. 170.

Fragment of offering-list, probably from here, in Heidelberg, Äg. Inst. 27. EVERS, *Staat aus dem Stein*, i, Taf. 110; OTTO (E.), *Aus der Sammlung des Ägyptologischen Institutes der Universität Heidelberg* (1964), Abb. 11, p. 91.

Hieratic graffito of Mery-inher(t) , Administrator of the ruler's table(?), son of Sonb, Dyn. XII or 2nd Int. Period, in Cairo Mus. CG 25380. DE MORGAN, *Dahchour*, i, fig. 272, p. 117. Transcription, DARESSY, *Ostraca (Cat. Caire)*, p. 100.

Wooden statuette, Middle Kingdom, in Cairo Mus. CG 515. DE MORGAN, op. cit. i, figs. 270, 274, p. 117; BORCHARDT, *Statuen*, ii, Bl. 88, p. 78.

PYRAMID. Lepsius, LVIII; Black Pyramid.

ARNOLD and STADELMANN in *Mitt. Kairo*, 33 (1977), pp. 18-20 [4], with section and view of interior, Abb. 3 and Taf. 3 [a]; L. D. Text, i, p. 209; VYSE, *Operations*, iii, pp. 70-1; DE MORGAN, *Dahchour*, i, pp. 87-8; ii, pp. 102-5; BURTON MSS. 25618, 14. Section, PERRING, *Pyramids*, iii, pl. xiii [13]. View, FRITH, *Cairo, Sinai, Jerusalem* [etc.] (1860), 23rd pl.; MARIETTE, *Mastabas*, fig. on p. 575; DE MORGAN, *Dahchour*, i, pls. xxxii, xl; id. in *Le Monde Moderne*, Jan. 1895, fig. on p. 76; WARD (J.), *Pyramids and Progress*, fig. on p. 54 [lower]; EVERS, *Staat aus dem Stein*, i, Taf. 108; BORCHARDT and RICKE, *Egypt*, pl. 97; HELCK, *Geschichte des Alten Ägypten*, Taf. iii [9]; MENDELSSOHN, *The Riddle of the Pyramids*, pl. 44;

D'ERME, *Egiziani costruttori*, fig. on p. 32 [upper]; of entrance, ARNOLD in *Archiv für Orientforschung*, xxv (1974-7), Abb. 9 on p. 322; id. and STADELMANN in *Mitt. Kairo*, 31 (1975), Taf. 111 [a], cf. Abb. 2 facing p. 170 (section).

Pyramidion of Amenemhêt III, granite, in Cairo Mus. JE 35133 (also JE 35745). E and N faces (of Maspero), and all texts, MASPERO in *Ann. Serv.* iii (1902), pp. 206-8 with pl.; E and usually one other face, id. *Égypte*, fig. 182; BREASTED, *History*, fig. 94; id. *The Dawn of Conscience*, fig. 6 facing p. 58; PIER, *Inscriptions of the Nile Monuments*, fig. 3; EVERS, *Staat aus dem Stein*, i, on Taf. 109; MITRY, *Illus. Cat.* No. 626; VAN DER LEEUW, *De Godsdienst van het oude Aegypte*, pl. 14 facing p. 36; GIEDION, *The Eternal Present*, ii, fig. 287; BRUNNER-TRAUT, *Die Alten Ägypter*, Taf. 33; VANDERSLEYEN, *Das Alte Ägypten*, Abb. 56; RUFFLE, *Heritage of the Pharaohs*, fig. 42; *Ancient Egypt: Discovering its Splendors*, fig. on p. 78 [right]; TEICHMANN, *Der Mensch und sein Tempel. Ägypten*, Abb. 4. 2nd line of text on W face (of Maspero), FISCHER, *The Orientation of Hieroglyphs*, i, fig. 60, p. 56. See SCHÄFER in *Ä.Z.* 41 (1904), pp. 84-5; MASPERO, *Guide*, p. 176 [626].

Masons' graffiti, in burial chamber. DE MORGAN, *Dahchour*, ii, fig. 152, p. 104.

Fragment of canopic-jar of Hathor-hotpet $\begin{matrix} \text{⊙} \\ \text{⊕} \\ \text{⊕} \end{matrix}$, King's daughter, in Cairo Mus. JE 59175. Id. ib. ii, fig. 154, p. 105.

TOMBS IN NORTH PART OF ENCLOSURE

I. King AWIBRĒ I $\begin{matrix} \text{⊙} \\ \text{⊕} \\ \text{⊕} \end{matrix}$ HOR $\begin{matrix} \text{⊕} \\ \text{⊕} \\ \text{⊕} \end{matrix}$ (or $\begin{matrix} \text{⊕} \\ \text{⊕} \\ \text{⊕} \end{matrix}$). Dyn. XIII.

DE MORGAN, *Dahchour*, i, pp. 88-106, with plans and sections, figs. 206, 208, 211, 242 (on p. 89)-244bis; id. in *Le Monde Moderne*, Jan. 1895, pp. 77-80, with section, fig. on p. 79 [left]; id. in *Comptes rendus* (1894), pp. 171-2.

Two alabaster stelae, with offering-text, and with 14 columns of Pyramid-texts, in Cairo Mus. JE 30952, 30951. Texts, id. *Dahchour*, i, figs. 218, 217, pp. 94 [4, 3], 165.

Circular offering-table, in Cairo Mus. JE 30953. Text, id. ib. i, fig. 219, p. 95 [5].

Wooden rectangular coffin (gold leaf with texts, in Cairo Mus. CG 28106, and fragment with *usat*-eyes, CG 28100). Id. ib. i, pl. xxxvi [bottom], figs. 241, 241bis, p. 101. CG 28100 and 28106, LACAU, *Sarcophages*, ii, pl. xix (CG 28100), pp. 77, 84-5. Texts, DE BUCK, *Coffin Texts*, vii, Da 4 C. CG 28100, see MASPERO, *Guide*, p. 331 [3298].

Mummy-mask, wood, in Cairo Mus. CG 28107. DE MORGAN, *Dahchour*, i, fig. 229, p. 98; id. in *Le Monde Moderne*, Jan. 1895, fig. on p. 79 [right]; see LACAU, op. cit. ii, p. 85.

Canopic-chest, wood with gold leaf (fragments in Cairo Mus. JE 51266), with clay sealing of Amenemhêt III. DE MORGAN, *Dahchour*, i, pls. xxxvi [middle right], xxxvii, figs. 245-6, pp. 102, 104-5.

Four canopic-jars, alabaster, in Cairo Mus. CG 4019-22. REISNER, *Canopics*, pl. iv, pp. 11-14; EVERS, *Staat aus dem Stein*, i, Taf. 134 [upper]. Texts, DE MORGAN, *Dahchour*, i, fig. 247, p. 106. See REISNER in *Ä.Z.* xxxvii (1899), pp. 62 [12], cf. 64 [I, b]; MASPERO, *Guide*, p. 328 [3280].

Wooden *ka*-statue,¹ in Cairo Mus. CG 259 (with fragment of *ka*-sign, CG 1159), found in wooden naos, CG 70035 (fragments of inscribed gilded plaster, formerly in Hilton Price Colln., now in Copenhagen, Ny Carlsberg Glypt. Æ.I.N. 1382). DE MORGAN, *Dahchour*, i, pls. xxxiii-xxxv, figs. 212-16, pp. 91-2 [1, 2]. CG 259 and 1159, BORCHARDT, *Statuen*, i, Bl. 56 (CG 259), p. 166, and iv, Bl. 164, p. 84. CG 259 and 70035, CAPART, *L'Art ég.* ii, pl. 288; GUIMET in *Revue de l'Histoire des Religions*, lxxviii (1913), figs. 1, 2, pp.

¹ Selected references.

12-13; ROSS, *The Art of Egypt*, pl. on p. 138 [2]; SCHWEITZER, *Das Wesen des Ka*, Taf. iii [b]; LANGE and HIRMER, *Aegypten. Architektur* (1955 and 1957), pls. 112-13; (1967), pls. 120-1; SMITH, *Art . . . Anc. Eg.* pl. 65 [A], pp. 100, 102; MONTET, *Eternal Egypt*, pl. 45; HAYES in *The Cambridge Ancient History*, Plates to Vols. i and ii (1977), 70; SHURINOVA, *Iskusstvo Drevnego Egipta*, pl. 51; MASPERO, *Guide*, fig. 37 (CG 259), pp. 101-2 [280-1]; *Descr. somm.* No. 280 with pl. CG 259, DE MORGAN in *Le Monde Moderne*, Jan. 1895, figs. on pp. 80, 81; CAPART, *L'Art ég.* (1909), pl. 40; VON BISSING, *Denkmäler*, i, Taf. 40A [left], and *Text* [1st fig.]; TARCHI, *L'Architettura*, Tav. 17 [upper right]; BULLE, *Der schöne Mensch im Altertum*, Taf. 11, 12; WEIGALL, *Anc. Eg. . . . Art*, 113-14; STEINDORFF, *Kunst*, 204; BREASTED, *History*, fig. 88; MURRAY, *Sculpture*, pl. xviii [4]; SCHÄFER and ANDRAE, *Kunst* (1925), 273; (1930 and 1942), 285; PIJOÁN, *Summa Artis*, iii (1945), fig. 247; ALDRED, *M.K. Art*, pl. 79; DONADONI, *Egyptian Museum Cairo*, pl. on p. 80; *Great Museums*, pl. 50 and fig. on p. 88; MICHALOWSKI, *Piramidy i mastaby*, pls. 25-6; SUZUKI, *Sculpture of the World*, 3, *Egypt*, pl. 76 and fig. on p. 140; incomplete, DAUMAS, *Civ. de l'Ég.* pl. 124; VANDIER, *Eg. Sculpture*, pl. 55; JAMES, *Egyptian Sculptures*, pl. 9; WOLF, *Kunst*, Abb. 275; MICHALOWSKI, *Art*, fig. 330; WESTENDORF, *Das Alte Ägypten*, fig. on p. 96. CG 70035, ROEDER, *Naos (Cat. Caire)*, Taf. 40 [a], pp. 121-2. Copenhagen Æ.I.N. 1382, KOEFOED-PETERSEN, *Catalogue des sarcophages et cercueils égyptiens*, pl. xix, p. 14 [4]; parts of texts, HILTON PRICE, *A Catalogue of the Egyptian Antiquities* [etc.], i (1897), p. 454 [3819].

Wooden gold-leaf covered *ka*-statuette (fragments of probably this statuette in Cairo Mus. CG 1163), originally in wooden naos. Text on base, DE MORGAN, *Dahchour*, i, fig. 209, pp. 90, 95 [7], cf. fig. 220. Cairo CG 1163, BORCHARDT, *Statuen*, iv, Bl. 164, p. 86.

Two libation-vases, alabaster, fragmentary (now restored), in Cairo Mus. CG 4028-9. REISNER, *Canopics*, pl. vi, pp. 17-18 (lids not belonging). Text, DE MORGAN, *op. cit.* i, fig. 210, pp. 90, 95 [6].

2. NUBHETEPTI-KHRED , King's daughter. Dyn. XIII.

DE MORGAN, *Dahchour*, i, pp. 107-15, with plans, figs. 249-50; id. in *Le Monde Moderne*, Jan. 1895, pp. 80-2, with plan on p. 82; id. in *Comptes rendus* (1894), pp. 172-5.

Wooden rectangular coffin (gold leaf with texts, in Cairo Mus. CG 28104). DE MORGAN, *Dahchour*, i, pl. xxxvi [top], figs. 263, cf. 264, p. 110. Texts of Cairo CG 28104, LACAU, *Sarcophages*, ii, pp. 81-2; DE BUCK, *Coffin Texts*, vii, Da 2 C.

Canopic-chest, wood with gold leaf (in Cairo Mus. JE 51268). DE MORGAN, *Dahchour*, i, pl. xxxvi [middle left], fig. 268, p. 115.

Four canopic-jars, alabaster, in Cairo Mus. CG 4007-10. REISNER, *Canopics*, pl. i, pp. 4-7. Texts, DE MORGAN, *Dahchour*, i, fig. 269, p. 115. See REISNER in *Ä.Z.* xxxvii (1899), pp. 62 [12], 64 [II], cf. fig. 3 [right] (CG 4010); MASPERO, *Guide*, p. 328 [3281].

Seven inscribed ointment-jars, alabaster, in Cairo Mus. CG 18722-8, in wooden box, CG 18721, sealed by Senebtifi , Real royal acquaintance. DE MORGAN, *Dahchour*, i, figs. 258-62, pp. 109-110. CG 18721-8, see VON BISSING, *Steingefässe (Cat. Caire)*, pp. 153-5 (texts).

BUILDING NORTH OF CAUSEWAY.

DE MORGAN, *Dahchour*, ii, p. 100, with plan and section, figs. 145-6. View, ARNOLD and STADELMANN in *Mitt. Kairo*, 31 (1975), Taf. 110 [a], pp. 171, 173.

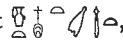
Fragments of false-door and offering-table of Khnemt-neferhezet-cat , King's wife (of Amenemhêt III), etc. DE MORGAN, *Dahchour*, ii, figs. 147-8, p. 100.

REMAINS OF BUILDING SOUTH OF CAUSEWAY. Plan, id. ib. ii, fig. 150, p. 102.

Sandstone jamb-fragment of Amenemhêt III. Id. ib. ii, fig. 149, p. 102.

G AND H. PYRAMIDS PROBABLY OF DYNASTY XIII

ARNOLD and STADELMANN in *Mitt. Kairo*, 31 (1975), p. 174 [3].

I. PYRAMID OF AMENY-ḲEMAU . Dyn. XIII

MARAGIOGLIO and RINALDI in *Orientalia*, n.s. 37 (1968), pp. 325–38, with plans and sections, pls. li, lii, and views, pls. liii–lx [1–21]; LECLANT in ib. n.s. 27 (1958), pp. 81–2 [10] with note 7; H. BR[UNNER] in *Archiv für Orientforschung*, xviii (1957–8), pp. 479–80; GABRA, *Chez les derniers adorateurs du Trismegiste*, p. 205; ARNOLD and STADELMANN in *Mitt. Kairo*, 31 (1975), p. 174 [3], with view, Taf. 112 [a], and position, on Abb. 3.

Inscribed canopic-jar fragments, in Cairo Mus. Temp. Nos. 25.11.60.1–4.

II. Necropolis

Maps LXXIII, LXXIV

A. EAST OF THE NORTHERN PYRAMID OF SNEFRU

NORTHERN PART (SOUTH-EAST OF THE ENCLOSURE OF SESOSTRIS III)

5. Probably Dyn. IV.

DE MORGAN, *Dahchour*, i, p. 9, with plan, fig. 6.

Reserve-head, probably female, in Cairo Mus. CG 519. Id. ib. i, fig. 7; SMITH, *Hist. Eg. Sculp.* pl. 6 [a], p. 27 [29]; SIMPSON in *M.M.A. Bull.* n.s. vii (June 1949), fig. on p. 289 [left]. See BORCHARDT, *Statuen*, ii, p. 79.

7. Mastaba-group. Probably Dyn. V.

DE MORGAN, *Dahchour*, i, pp. 11–13, with plan, fig. 9. Dating as late Old Kingdom, SCHMITZ, *Untersuchungen zum Titel ss-njswt 'Königsson'*, pp. 150–1 [IV].

Male statue, headless, from Tomb a. DE MORGAN, op. cit. i, fig. 10.

Offering-table of Ni'ankhrēc , Royal acquaintance, from Tomb b. Name, id. ib. i, p. 12.

Fragments of false-door of Ka'ahaf , King's son of [his body], Overseer of the expedition, Prophet of Snefru, etc. (four fragments in Cairo Mus. CG 1381–3, 1672). Id. ib. i, figs. 12, 13. Texts of CG 1381–3, 1672, BORCHARDT, *Denkmäler*, i, pp. 41–2; ii, p. 129.

SOUTHERN PART (NORTH OF THE ENCLOSURE OF AMENEMHÊT II)

Plan LXXIV (inset)

Plan, DE MORGAN, *Dahchour*, ii, pl. ii.

1. SESHEMNŪFER , Scribe of the royal documents in the presence. 2nd half of Dyn. V or Dyn. VI.

DE MORGAN, *Dahchour*, ii, pp. 2-3, with plan, fig. 2.

Fragments of north false-door. Deceased carried in palanquin, in Berlin (East) Mus. 15790; id. ib. ii, fig. 3; Szépművészeti Múzeum, Budapest. *Egyiptomi művészet* [etc.] (1975), No. 13 with fig. 2; see *Führer* (1961), p. 44. Offering-bringers, DE MORGAN, op. cit. ii, fig. 4.

South brick-built false-door. Men bringing unguents, painted, in Cairo Mus. CG 1783, 1785. Id. ib. ii, fig. 5; BORCHARDT, *Denkmäler*, ii, Bl. 109, pp. 203, 204.

Painted scenes of carpenters and butchers, latter in Cairo Mus. CG 1781. DE MORGAN, op. cit. ii, figs. 6, 7; Cairo CG 1781, BORCHARDT, op. cit. ii, Bl. 108, p. 202.

2. IN-SNEFRU-ISHTEF , Inspector of tenants of the Great House, etc. Dyn. V-VI.

DE MORGAN, *Dahchour*, ii, pp. 4-7, with plan, on fig. 8, and section of shaft, fig. 12. Date, BALCZ in *Ä.Z.* 67 (1931), pp. 9-15.

False-door, in Dundee, Mus. and Art Gallery, 66.222. DE MORGAN, op. cit. ii, fig. 9.

Wall-paintings, in Cairo Mus. CG 1769-80. All, BORCHARDT, *Denkmäler*, ii, Bl. 102-7, pp. 188-202. CG 1769, remains of two registers, **I**, men carrying [palanquin], **II**, freight-boats; DE MORGAN, op. cit. ii, pl. xx; boats, WRESZ., *Atlas*, i. 411; boat on right, KÖSTER, *Das antike Seewesen*, Taf. 5. CG 1770, two registers, **I**, bringing donkeys, piling up sheaves, winnowing, **II**, rowing-boats; DE MORGAN, op. cit. ii, pl. xxi; piling up sheaves, id. *Recherches*, i, fig. 522; boats, WRESZ., op. cit. i. 409. CG 1771, remains of registers before [deceased] and attendants, presenting fowl in **I**, and unloading fish in **II**; unloading fish, id. ib. i. 413; DE MORGAN, *Recherches*, i, fig. 519; FARINA, *La Pittura egiziana*, Tav. xi (from WRESZ.). CG 1772, netting fish; DE MORGAN, *Dahchour*, ii, pl. xxiii; WRESZ., op. cit. i. 412 (reversed). CG 1773, two sailing-boats; DE MORGAN, *Dahchour*, ii, pl. xix; WRESZ., op. cit. i. 410; boat on right, JÉQUIER in *B.I.F.A.O.* ix (1911), pl. iii [1], p. 58 note 2. CG 1774, registers, **I** (lower part only), bringing cattle before deceased and wife, **II**, estates; DE MORGAN, *Dahchour*, ii, pl. xviii; WRESZ., op. cit. i. 415; names, JACQUET-GORDON, *Domaines*, pp. 440-1 [4D6], cf. figs. 191-2. CG 1775, lower part of two scenes, deceased and family spearing fish and fowling; DE MORGAN, *Dahchour*, ii, pl. xxiv. CG 1776, registers of funeral scenes, **I** (almost completely lost), men dragging sledge, **II**, rowing-boats towing boat with shrine, **III**, men towing boat towards embalming-house, with butchers; id. ib. ii, pl. xxii; **III**, JUNKER in *Mitt. Kairo* 9 (1940), Abb. 2, pp. 10-12; embalming-house and lector-priest, BORCHARDT, *Ägyptische Tempel mit Umgang in Beiträge zur ägyptischen Bauforschung*, 2, Abb. 7, pp. 24-5; see WERBROUCK, *Pleureuses*, pp. 79-80. CG 1777, deceased seated, with monkey under chair, and [man] making bed under canopy. CG 1778, lady guest, and two registers of female dancers and musicians from banquet scene; DE MORGAN, *Dahchour*, ii, pl. xxv; HICKMANN, *45 Siècles*, pls. lxi, cii; id. in *Bull. Inst. Ég.* xxxv (1952-3), pl. ii, p. 320; dancers and musicians, WRESZ., op. cit. i. 414. CG 1779-80, lower part of deceased seated and offerings, with offering-bringers below.

Wall-paintings, perhaps also from here, but more likely from another tomb. Lower part of two scenes, deceased and family (including son Nikau[p]tah , Inspector of tenants of the Great House) spearing fish and fowling (canoe with fish from fishing scene in Cairo Mus. CG 1782 and 1786); DE MORGAN, *Recherches*, i, fig. 516; CG 1782 and 1786,

BORCHARDT, *Denkmäler*, ii, Bl. 108, 109, pp. 203, 205; CG 1786, GALASSI, *L'arte del più antico Egitto* [etc.] in *Rivista dell'Istituto Nazionale d'Archeologia* [etc.], N.S. iv (1955), fig. 63, p. 62; DAVIES (NINA), *Ancient Egyptian Paintings*, i, pl. iv; SMITH, *Hist. Eg. Sculp.* pl. 51 [b], pp. 205-6 note 2; DAVIES MSS. photo. 1.328. Two registers before deceased (lower part only) and son, netting fowl, and cattle crossing water, with herdsmen in canoe (right part of latter, with stern of canoe and cattle, in Cairo Mus. CG 1784); DE MORGAN, *Recherches*, i, fig. 517; Cairo CG 1784, BORCHARDT, *Denkmäler*, ii, Bl. 109, p. 204; CAPART, *Memphis*, fig. 374; id. *L'Art ég.* iii, pl. 420; part, MÜLLER (H. W.) in *Encyclopedia of World Art*, iv, pl. 328 [lower].



Lower part of pair-statue. DE MORGAN, *Dahchour*, ii, fig. 13.

7. NEFERIRTNES , Inspector of tenants of the Great House. Dyn. VI.

DE MORGAN, *Dahchour*, ii, pp. 10-11, with plan, fig. 21.

Offering table of woman Khenti , in Corridor. Id. ib. ii, fig. 25.

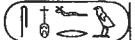
False-door, from Offering-room, in Cairo Mus. CG 1393. Id. ib. ii, fig. 22; text, BORCHARDT, *Denkmäler*, i, p. 54.

8. NI'ANKH-SNEFRU  FEFI , Judge and Inspector of scribes, etc. Probably Dyn. VI.

DE MORGAN, *Dahchour*, ii, pp. 11-12, with plan, on fig. 26.

False-door, in Cairo Mus. CG 57122. Id. ib. ii, fig. 27.

Drum with names and title, in Cairo Mus. CG 1489. Text, BORCHARDT, *Denkmäler*, i, p. 190.

Small false-door and lintel of Shepy , Chief of the estate, Lector-priest, etc. Texts, DE MORGAN, op. cit. ii, figs. 28-9.

11. NEFERHER-SNEFRU  , King's son. Probably Dyn. V or VI.

DE MORGAN, *Dahchour*, ii, p. 14, with plan, on fig. 26.

Drum of doorway with name and title, in Cairo Mus. CG 1487. Text, id. ib. ii, fig. 32; BORCHARDT, *Denkmäler*, i, p. 189.

12. UZAU , Overseer of the department of tenants of the Great House, Overseer of interpreters, etc. Dyn. VI.

DE MORGAN, *Dahchour*, ii, pp. 14-15, with plan, fig. 33.

Lintel of doorway with offering-text, in Berthoud (Burgdorf), *Sammlung für Völkerkunde*, 7613. Id. ib. ii, fig. 34.

24. Probably Dyn. VI.

DE MORGAN, *Dahchour*, ii, pp. 18-21, with plan, on fig. 43.

Statuettes from serdāb. All wood. Numbers are those of Cairo Mus.

Woman grinding corn, CG 504. Id. ib. ii, fig. 44, p. 18 [1]; id. *Recherches*, i, fig. 325;

BORCHARDT, *Statuen*, ii, Bl. 86, p. 73; CHAMPDOR, *Thèbes aux Cent Portes*, fig. on p. 32. See BREASTED (Jr.), *Eg. Servant Statues*, p. 21 [e, 4].

Rower, and kneeling man. DE MORGAN, *Dahchour*, ii, figs. 45-6, p. 18 [2, 3].

Two female offering-bringers with basket on head, CG 509-10. Id. ib. ii, fig. 47 (one), pp. 18-20 [4, 5]; BORCHARDT, op. cit. ii, Bl. 87 (CG 509), pp. 75-6; one, see BREASTED (Jr.), op. cit. p. 61 [4].

Man seated, CG 517. DE MORGAN, *Dahchour*, ii, fig. 48, p. 20 [6]; BORCHARDT, op. cit. ii, Bl. 88, p. 78.

Two, man standing (one CG 503). DE MORGAN, *Dahchour*, ii, fig. 49 (CG 503), p. 20 [7, 8]. CG 503, BORCHARDT, op. cit. ii, Bl. 85, p. 73.

Two groups, originally four 'servants of the estate of Shepy' (cf. *supra*, tb.8) each (only three of each left), CG 511-12. DE MORGAN, *Dahchour*, ii, pl. iii (CG 511), pp. 20-1 [9, 10]; BORCHARDT, op. cit. ii, Bl. 87-8, pp. 76-7. CG 511, TARCHI, *L'Architettura*, Tav. 17 [upper left]. See BREASTED (Jr.), op. cit. p. 60 [17].

Two seated and four standing statuettes. See DE MORGAN, *Dahchour*, ii, p. 21 [11-16].

Four standing statuettes, CG 505, 516, 514, 506. Id. ib. ii, pl. iv, p. 21 [17-20] (misreading title as name); BORCHARDT, op. cit. ii, Bl. 86 (CG 505-6), pp. 73-4, 77, 78. CG 506, see BOREUX in *Revue de l'Art ancien et moderne*, lxxi (1937), p. 212, cf. fig. 3 (from BORCHARDT).

Other statuettes, some fragmentary. See DE MORGAN, *Dahchour*, ii, p. 21 [21-30].

27. KEDSHEPSES , King's son of his body, Prophet of Snefru, etc. Probably Dyn. V or later.

DE MORGAN, *Dahchour*, ii, p. 22, with plan, on fig. 50. Dating as late Dyn. VI or 1st Int. Period, SCHMITZ, *Untersuchungen zum Titel sꜣ-njꜣwt 'Königsson'*, p. 149 [III].

False-door jamb, with names and titles of deceased and sons, in Cairo Mus. CG 1390. Texts, DE MORGAN, op. cit. ii, fig. 51; BORCHARDT, *Denkmäler*, i, p. 51.

28. KANŪFER , King's eldest son of his body, Overseer of the Pyramid of Snefru, etc.¹ Advanced Dyn. IV or later.

Wife, Khunesu , King's adorer, etc.

DE MORGAN, *Dahchour*, ii, p. 23, with plan, fig. 52. Dating as end Dyn. VI to Dyn. VIII, SCHMITZ, *Untersuchungen zum Titel sꜣ-njꜣwt 'Königsson'*, pp. 145-9 [II].

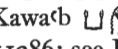
South niche in east façade, with false-door. DE MORGAN, op. cit. ii, pl. xxvi, fig. 53. Central part of false-door, in Brit. Mus. 1324; *Hiero. Texts*, i, pl. 4; i², pl. x [1], p. 10; *Guide (Sculpture)*, pl. i, p. 4 [8] (as Gîza); *Wall Decorations of Egyptian Tombs*, fig. 1; dedication of eldest son Kawaḥ , Royal acquaintance, SETHE, *Urk.* i. 227 [5 (145), A]. Niche, in Louvre, E.11286; see BOREUX, *Guide*, i, p. 230; VANDIER, *Guide* (1948 and 1952), p. 8; (1973), p. 12.

Offering-table, dedicated by son Kanūfer, in Brit. Mus. 1345. DE MORGAN, *Dahchour*, ii, fig. 54; *Hiero. Texts*, i, pl. 5 [9]; i², pl. ix [2], p. 9; see *Guide (Sculpture)*, p. 5 [9] (as Gîza).

Drum, perhaps from here, in Louvre, C 155 [E.3908]. WILKINSON MSS. xviii. 43 [right]. Name and titles, PIERRÉT, *Rec. inscr.* ii, p. 56. See DE ROUGÉ, *Notice des monuments* (1883), p. 134; BOREUX, *Guide*, i, p. 236.

¹ Also Chief Justice and Vizier, in unclear context.

B. EAST OF THE SOUTHERN PYRAMID OF SNEFRU

IYNÛFER , King's son, etc. Early Dyn. IV.

BARSANTI in *Ann. Serv.* iii (1902), pp. 198–201 [I], with plans, sections, and elevations, figs. 1–6; MASPERO, *Trois années de fouilles* [etc.] in *Mém. Miss.* i, pp. 189–90 [1].

Lower parts of two niches, with estates on thicknesses, in Cairo Mus. CG 57121, 57120 (JE 38563–4). BARSANTI, op. cit. pls. i, ii, pp. 198–9. Jambs and rear wall of CG 57120, and upper part of deceased from rear wall of CG 57121, STAEHELIN, *Tracht*, Taf. vi [10], xv [23]. Right jamb of CG 57120, SMITH, *Hist. Eg. Sculp.* pl. 36 [b], p. 150; id. *Art . . . Anc. Eg.* pl. 28 [A], p. 41. Names of estates, JACQUET-GORDON, *Domaines*, pp. 430–3 [1D4], cf. figs. 183–6, with pl. i facing p. 201 (estate No. 14, from CG 57120). Hieroglyph of ram in name of estate No. 1 (of JACQUET-GORDON) on CG 57121, KEIMER in *Ann. Serv.* xxxviii (1938), pl. xl, p. 299. Texts of CG 57120, WILBOUR MSS. 2 G, 62 [top]. See MASPERO, *Guide*, p. 39 [75A, B].

DUARĒC , Overseer of the two Pyramids of Snefru, Prophet of RēC in the Sun-temple of Userkaf,¹ *wa^cb*-priest of the Pyramid of Userkaf,¹ etc. Temp. SaḥurēC or later.

Wife, Mertiotēs , Royal acquaintance.

MASPERO, *Trois années de fouilles* [etc.] in *Mém. Miss.* i, pp. 190–1 [2], with plan. Some texts, WILBOUR MSS. 2 G, 63, 64 [lower]. Names, titles, and names of two estates, LIEBLEIN, *Dict.* No. 1379.

Outer Room.

False-door of deceased and eldest son 'Ankhma'rēC , Overseer of the southern Pyramid of Snefru, etc., in Cairo Mus. CG 1389. BORCHARDT, *Denkmäler*, i, Bl. 12, pp. 49–51, cf. ii, Bl. 58 [1552A, lintel]; some texts, MASPERO, op. cit. p. 190; names and some titles, LIEBLEIN, *Dict.* No. 1363.

Offering-basins, in Cairo Mus. Deceased, CG 1375; text, BORCHARDT, op. cit. i, p. 34. 'Ankhma'rēC, CG 1325; id. ib. i, Bl. 4, p. 11.

Inner Room.

Doorway, lintel, and jambs with names and titles, and thicknesses, registers, I, III, IV, estates, II, bringing oryx, in Cairo Mus. CG 1552. Id. ib. ii, Bl. 58 (lintel belongs to CG 1389), pp. 9–13; texts of thicknesses, MASPERO, op. cit. pp. 190–1; names of estates, JACQUET-GORDON, *Domaines*, pp. 436–9 [3D5], cf. figs. 189–90.

KAWEZ'ANKH , Boundary official of a frontier district, Overseer of the phylai of Upper Egypt, etc. Middle Dyn. V.

Parents, Nesutnūfer (not mentioned here) and Khentetka Khent  (Giza tb. G 4970, *Bibl.* iii². 143–4).

MASPERO, *Trois années de fouilles* [etc.] in *Mém. Miss.* i, p. 191 [3], with name and title from lintel of doorway; cf. FISCHER in *J.A.O.S.* 74 (1954), pp. 27–8.

False-door, in Brit. Mus. 1223. *Hiero. Texts*, i, pl. 15 [65]; i², pl. viii [2], p. 8; part of text, WILBOUR MSS. 2 G, 62 [middle].



¹ On offering-basin Cairo CG 1375 only.

NEFERMA'ET , Overseer of the phylai of Upper Egypt, etc. Middle Dyn. V.

Parents, Nesutnūfer and Khentetka Khent (latter not mentioned here) (Giza tb. G 4970, *Bibl.* iii². 143-4).

BARSANTI in *Ann. Serv.* iii (1902), pp. 203-4 [IV, V] (probably same tomb); cf. FISCHER in *J.A.O.S.* 74 (1954), pp. 26-9.

Lintel and drum of false-door, mentioning deceased and father, in Cairo Mus. CG 57143. Texts, BARSANTI, *op. cit.* p. 204 [V]; WILBOUR MSS. 2 G, 62 [bottom]; of lintel, MASPERO, *Trois années de fouilles* [etc.] in *Mém. Miss.* i, p. 191 [4, 1st text].

Relief-fragments. (a) Deceased and wife at table. (b) Two registers with four people seated, including brothers of deceased Kaemib , Sole companion, and Kaḥersetef , Inspector of boats, in Cairo Mus. CG 57142. (c) Lintel or drum with name and titles. (d) Couple standing. Texts of all, BARSANTI, *op. cit.* pp. 203-4 [IV]; of (c), MASPERO, *op. cit.* p. 191 [4, 2nd text].

ITHI , Overseer of the chamber of dancers, etc. Dyn. IV-V.

Wife, Wesenptah(?) , *mitrt.*

Deceased and wife seated, with two sons and two daughters. Texts, MASPERO, *Trois années de fouilles* [etc.] in *Mém. Miss.* i, p. 191 [5]; some names and titles, LIEBLEIN, *Dict.* No. 1372.

THENTI , Prophet of Snefru, etc. Old Kingdom.

Name and titles from lintel of doorway, MASPERO, *Trois années de fouilles* [etc.] in *Mém. Miss.* i, p. 191 [6].

KAEMKED , Prophet of Snefru(?), Secretary [of the King in] all his places, etc. Probably Dyn. V.

Mother, Nefertnesut , King's daughter, Prophetess of Snefru and Ḥaḥor Mistress of the Sycamore, etc.

Lower part of false-door, in Cairo Mus. JE 37953. Texts, BARSANTI in *Ann. Serv.* iii (1902), pp. 202-3 [III]; WILBOUR MSS. 2 G, 64 [upper]. Dating as late Old Kingdom, SCHMITZ, *Untersuchungen zum Titel s3-njswt 'Königssohn'*, pp. 151-2 [V].

KARES , Prophet of Snefru, etc. Old Kingdom.

Wife, Merestankh , Prophetess of Ḥaḥor Mistress of the Sycamore, etc.

Lower part of false-door. Texts, BARSANTI in *Ann. Serv.* iii (1902), pp. 201-2 [II].

FINDS

Two standing statues, headless, Old Kingdom. GABRA, *Chez les derniers adorateurs du Trismegiste*, fig. on p. 209, cf. p. 205.

C. NORTH OF THE ENCLOSURE OF SESOSTRIS III

Plan LXXV

Plan and views, DE MORGAN, *Dahchour*, i, pls. iv, v, fig. 18.

2. KHNEMHOTP , Chief Justice and Vizier, etc. Probably temp. Sesostris III.

DE MORGAN, *Dahchour*, i, pp. 18-23, with plan and section, figs. 20-1.



Frieze with offering-texts, from exterior (fragment formerly in Likhachev Colln. and Leningrad, Institute of Books, Documents and Manuscripts of the Academy of Sciences of U.S.S.R., now in Leningrad, State Hermitage Mus. 18230, and another in Marschall Colln.). Id. ib. i, fig. 24. Leningrad 18230 (= fig. 24, C, 2nd line right), PEREPELKIN, *Fragment d'une inscription égyptienne de la 12^e dynastie* [etc.] in *Comptes Rendus de l'Académie des Sciences de l'U.R.S.S.*, 1929, fig. on p. 20 (in Russian); LANDA and LAPIS, *Egyptian Antiquities in the Hermitage*, pl. 19. Marschall Colln. block (= fig. 24, A, 2nd line left), ALTENMÜLLER in HORNOSTEL and others, *Kunst der Antike* (1977), No. 8 with fig.

Fragments with titles, remains of autobiographical text, etc., including one mentioning deified Amenemhêt'ankh  (perhaps son of Amenemhêt II). DE MORGAN, op. cit. i, figs. 22-3, 25-6.

Canopic-chest, sandstone, in Cairo Mus. CG 4048. REISNER, *Canopics*, pl. lxxxii, pp. 28-32; texts, DE MORGAN, op. cit. i, fig. 28; see MASPERO, *Guide*, p. 110 [308].

6. Middle Kingdom.

DE MORGAN, *Dahchour*, i, p. 25, with plan and sections, fig. 33.

Offering-table of Tem'a , daughter of Sit-hathor  (mother). Id. ib. i, fig. 34.



8. NAME UNKNOWN. Middle Kingdom.

Mother, Sit-hathor .

DE MORGAN, *Dahchour*, i, pp. 25-6, with plan and section, fig. 37.

Fragment of false-door. Id. ib. i, fig. 36.

II. KHENTEKHTAIEMSAF , Embalmer. Temp. Sesostris III or later.

Mother(?), Sent . Wife, Sit-hathor .

DE MORGAN, *Dahchour*, i, pp. 27-30, with plans, section, and views, pls. vi-ix, figs. 41-3. View, id. in *Le Monde Moderne*, Jan. 1895, fig. on p. 69.

Fragments of reliefs and inscriptions, deceased and wife at tables, etc., from exterior, in Cairo Mus. CG 1468-77. Id. *Dahchour*, i, figs. 44-53; BORCHARDT, *Denkmäler*, i, Bl. 37 (CG 1477), pp. 158-64.

Offering-table, against east face. Text, DARESSY in *Rec. Trav.* xxiv (1902), p. 163 [cxvii].

Canopic-chest, in Cairo Mus. CG 4049. REISNER, *Canopics*, pl. lxxix, pp. 32-3; DE MORGAN, *Dahchour*, i, figs. 54-5; see MASPERO, *Guide*, p. 116 [361] (as Dyn. XIII).

17. SEBKEMḤĒT , Chief Justice and Vizier, etc. Probably temp. Sesostris III.

DE MORGAN, *Dahchour*, i, pp. 31-3, with plan, section, etc., figs. 61-3; cf. SIMPSON in *J.E.A.* 43 (1957), pp. 26-9.

Fragments of reliefs with offering-bringers and titles. DE MORGAN, *op. cit.* i, figs. 65-7. Fragments of offering-table. *Id. ib.* i, fig. 64.

18. NAME UNKNOWN, Hereditary prince, Count, etc. Temp. Sesostris III.

DE MORGAN, *Dahchour*, i, pp. 33-4.

Relief-fragments with [deceased] at table, offering-bringers and butchers. *Id. ib.* i, figs. 68-9.

19. Probably late Dyn. XII.

DE MORGAN, *Dahchour*, i, pp. 34-5, with plan and section, figs. 70-1.

Fragments of squatting statuette, diorite or granite (head formerly in Cairo Mus. CG 828 and von Bissing Colln., now in The Hague, Gemeente Museum voor Oude Kunst, 1952). Head and text, *id. ib.* i, figs. 72, 72a; head, VAN GELDER in *Mededeelingen van den Dienst voor Kunsten en Wetenschappen der Gemeente 's-Gravenhage*, v (1938), fig. 5, p. 9; SCHEURLEER in *Jaarbericht Ex Oriente Lux*, No. 7 (1940), pl. xvi, p. 550 [20]; see BORCHARDT, *Statuen*, iii, pp. 115-16.



22. Middle Kingdom.

DE MORGAN, *Dahchour*, i, pp. 35-6.

Texts of wooden coffin, *id. ib.* i, fig. 73 (by Daressy).

24. IPITI , Overseer of the department, etc. 2nd half of Dyn. XII.

DE MORGAN, *Dahchour*, i, p. 37, with section, fig. 77.

Stela, with Kha'kheperrē-sonb  | , Embalmer of the temple, before deceased, and uninscribed offering-table, in Cairo Mus. CG 1486. *Id. ib.* i, pl. xi, p. 165; BORCHARDT, *Denkmäler*, i, Bl. 41, pp. 187-8; see MASPERO, *Guide*, p. 113 [324].

25. KHNEḤOTP , Regulator of a phyle. Middle Kingdom.

Mother(?), Mereryt .

DE MORGAN, *Dahchour*, i, p. 38.

False-door, in Cairo Mus. CG 1478. *Id. ib.* i, fig. 79; BORCHARDT, *Denkmäler*, i, Bl. 38, p. 165.

27. NENI , Nubian (woman). Middle Kingdom.

DE MORGAN, *Dahchour*, i, pp. 38-9.

Stela, in Cairo Mus. CG 1481. *Id. ib.* i, fig. 80; BORCHARDT, *Denkmäler*, i, Bl. 38, pp. 168-9.

28. NEN...  (woman). Middle Kingdom.

DE MORGAN, *Dahchour*, i, p. 40.

Stela. Id. ib. i, fig. 81.

D. SOUTH OF THE ENCLOSURE OF AMENEMHËT II

SIËSI , Overseer of the seal, etc. Dyn. XII.



'Pyramid' LV of Lepsius.



DE MORGAN, *Dahchour*, ii, pp. 78-86.

Four relief-fragments, in Cairo Mus. Temp. Nos. 24.5.28.1-4. MASPERO, *Guide*, pp. 112 [319-20] with fig. 42 (one relief), 115 [334-5]. (a) *Sem*-priest, etc., before deceased at table, DE MORGAN, op. cit. ii, pl. xiv; MASPERO and ROEDER, *Führer*, Taf. 21 [a], p. 33 [224]; VANDERSLEYEN, *Das Alte Ägypten*, Abb. 276; head of deceased, MASPERO, *Égypte*, fig. 198. (b) Head of deceased, PIRENNE, *Hist. civ.* ii, pl. 31 facing p. 101.

Pyramid-texts, from walls of Burial Chamber. DE MORGAN, op. cit. ii, pp. 78-85 (by Legrain).

FINDS

Panel of false-door of Amenemhêt'ankh, King's son (probably of Amenemhêt II) (lower part, see *supra*), probably intrusive, and relief-fragment with two squatting men (including 'his brother' Amenemhêt'ankh ) , Regulator of a phyle). DE MORGAN, op. cit. ii, fig. 128.

Stela and offering-table of Senu'ankh , Boat-builder, son of H̄etep-h̄athor  H̄etep  (mother), Middle Kingdom, in Cairo Mus. CG 20528-9. Id. ib. ii, figs. 129-30; texts, LANGE and SCHÄFER, *Grab- und Denksteine des Mittleren Reichs (Cat. Caire)*, ii, pp. 129-31.

III. Miscellaneous

Old Kingdom.

Seated (headless) and standing statues, Dyn. V, in Cairo Mus. CG 507-8. BORCHARDT, *Statuen*, ii, Bl. 87 (CG 508), pp. 74-5.

Head, granite, in Cairo Mus. CG 1249. See id. ib. iv, p. 129.

False-door of Ismet , Noblewoman of the King, Prophetess of H̄athor, Dyn. VI or later, in Cairo Mus. CG 1395. Id. *Denkmäler*, i, Bl. 14, pp. 55-6; VANDIER, *Manuel*, ii, fig. 278 [lower right], p. 404.

Offering-table of Sethu , Judge and Overseer of scribes, Dyn. V-VI, in Cairo Mus. CG 1330. BORCHARDT, *Denkmäler*, i, Bl. 5, p. 14; MARIETTE, *Mon. div.* pl. 94; CAPART, *Memphis*, fig. 221; VANDIER, *Manuel*, ii, fig. 308 [bottom left], pp. 526-8 [3]; PETRIE GIZA photo. 555.

Offering-table 'of King Kakai (Neferirkarē)', in Cairo Mus. JE 37951.

Obelisk of Snefru... H̄etep , Overseer of commissions, Overseer of the five... of the Great House, Dyn. VI, found south of the Red Pyramid, in Cairo Mus. CG 1315. BORCHARDT, *Denkmäler*, i, Bl. 2, p. 8; text, KUENTZ, *Obélisques (Cat. Caire)*, pp. 6-7.

Bowl of King Kha'ba, diorite, said to come from here, formerly in Robinow Colln., now

in Manchester Mus. 5373. ARKELL in *J.E.A.* 44 (1958), p. 120 with figs.; KAPLONY in *Mitt. Kairo*, 20 (1965), Taf. vi [57], p. 27 [57]; see *The Museums Journal*, 59 (1959-60), p. 111.

Ink-slab of Zadkarē (Isesi), flint, bought in Cairo, said to come from here, in London, Univ. Coll. 11771. PETRIE, *History*, i (1894), fig. 48; (1923), fig. 61; id. *Objects of Daily Use*, pl. lvi [9], p. 63; id. KOPTOS photos. 30-1; text, id. *Scarabs and Cylinders*, pl. ix [5.8(3)]; see *Burlington Fine Arts Club* (1922), p. 89 [35].

Middle Kingdom.

Statuette of Khentiuka , son of Khentiuka, with offering-text invoking Snefru and Ptaḥ-Sokari, diorite, probably temp. Sesostri III, probably from here, formerly in Benzion Colln. and Meyers (G. H.) Colln., Washington (D.C.), 7.2, now in New York, M.M.A. 62.77. HAYES in *M.M.A. Bull.* n.s. xxi (Oct. 1962), fig. on p. 68, cf. p. 69; F.E.R.E. photo. 17647; see *Benzion Collection Sale Cat.* (Cairo, March 14, 1947), No. 186.

Upper part of seated statuette, grey hard stone, in Cairo Mus. CG 518. HORNEMANN, *Types*, iii, pl. 738. See BORCHARDT, *Statuen*, ii, pp. 78-9.

Seated statuette, wood, in Cairo Mus. CG 513. See id. *ib.* ii, p. 77.

Block(?) with texts of Senebsuma' , Overseer of the seal, etc. Text, MARIETTE, *Mastabas*, p. 583.

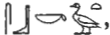
Gold leaf from coffin of woman Sitsobk , in Cairo Mus. CG 28105. Coffin-texts, LACAU, *Sarcophages*, ii, p. 83; DE BUCK, *Coffin Texts*, vii, Da 3 C.

Late Period.

Coffin of woman Ḥartesnakht . Text, MARIETTE, *Mastabas*, p. 584.

ADDENDA

The following notes complete the information on some monuments included in this volume, but do not attempt to add to the cited works or list all new material which has come to our notice since the publication of Fascicle 1 in 1978. Most of them are based on published or personal communications of other Egyptologists, in particular R. S. Bianchi, E. Brovanski, W. V. Davies, E. Edel, H. G. Fischer, R. Gillam, L. Limme, H. De Meulenaere, D. A. Pendlebury, B. J. Peterson, and A. Roccati. The footnotes on pages 420, 501, and 547 are to be disregarded.

Page

- 451 Tomb No. 9 [B 4], İpi. Thicknesses, in Ungar Colln., are on loan to Zürich, Rietbergmuseum.
- 452 Tomb No. 14 [D 43], Smenkhuṭtaḥ Itwesh. Delete Inv. 1841 of Vienna, Kunsthistorisches Museum.
- 463 Tomb No. 47 [E 3], Sabu Thety, is dated temp. Pepy II or later.
- 481 (2) Relief with geese and cranes, from 4th register, is in Turin Mus. Sup. 1257.
- 482 Tomb No. 73 [D 13], Shepsi. Father, Peḥnuika (tomb D 70 [LS 15]); wives of father, Zefatsen and Ḥetepḥeres. Date, probably middle Dyn. V.
- 491 (4) Zefatsen is Peḥnuika's wife.
- 503 Tomb of Unnūfer. Reliefs in Louvre, E. 3065, quoted on p. 760, should be moved here.
- 505 Sarcophagus of Zeḥo is the same as New York, M.M.A. 11.154.7, quoted on p. 765, so the entry should be deleted here.
- 506 Stela of Khaṣḥap. Delete Phoenician.
- 506 n. 1 Head of marble sarcophagus probably does not belong to the stela, and should be deleted.
- 507 Sarcophagus of Ḥarkhebi. Correct the name to Ḥaremḥab.
- 558 Tomb of Raṣwēr. Now published by el-Fikey, *The Tomb of the Vizier Rēc-wer at Saqqara*, and the date should be corrected to probably temp. Pepy I or later.
- 561 Shaft No. 289, Khenu and Ipiemsaf. Khenu is a Scribe and Treasurer of the God of the Pyramid of Merykarēc, Regulator of a phyle of the Pyramid of Teti, etc., so the dating probably is 1st Int. Period.
- 562 Statue of Thauineb-ḥezet. Correct the name of father to Khnemnakht.
- 570 Block of Meḥi. Part is in Amsterdam, Allard Pierson Mus. 8752 (formerly Zandee Colln.).
- 571 Ointment-slab of Sekhemptaḥ Sekhemu. Correct the title to Inspector of manicurists of the Great House.
- 589 Another two blocks are at Wildenstein Art Center, Houston (Texas).
- 638 Tomb of Akhtiḥotp. One wooden statue (No. 4 of Batrawi) is in Cairo Mus. JE 93167.
- 661 Tomb of Iurokhy. Correct the date to temp. Ramesses II.
- 691 Tomb of Inpukhaṣ. Lower part of false-door is in Wellcome Colln.
- 695 n. 1 This relief is now Brooklyn Mus. 79.176. Another relief was seen with Ede (dealer in London) in 1980.
- 698-9 Tomb of Tepemṣankh. This man is the same as Tepemṣankh quoted in *Bibl.* iii². 109, and the whole entry should be moved there.

Page

- 706 Tomb of Neferronpet. A relief-fragment is at Wildenstein Art Center, Houston (Texas).
- 707 Tomb of Nia. Lid of double ushabti-coffin of deceased and wife is in Boston Mus. 1977.717.
- 726 See note to p. 755.
- 732 See note to p. 757.
- 755 Four pillars of Khaꜣy, perhaps the same man as that mentioned on p. 726, are probably in Cairo Mus.
- 757 Lintel of Meru, the same man as that mentioned on p. 732, is in Dresden, Skulpturensammlung, Inv. Aeg. 753.
- 760 See note to p. 503.
- 762 The lintel-fragment of a Prophet of the Sun-temple of Userkaf is in Kristianstad Mus.
- 763 Sarcophagus-fragment of Unnūfer, Prophet, Royal scribe, son of Nebt-ḥyt (mother), Ptol., formerly Amherst and Kahn Collns., is in Bryn Athyn (Pa.), Museum of the Academy of the New Church. This is the same man as the owner of the lid in Cairo Mus. CG 29310, quoted on p. 764.
- 764 See preceding note.
- 773 Canopic-jars of Weḥebrēꜥ. The name of the mother should be read Webennesiꜥoḥ. Šaqqāra as the provenance of the piece is in doubt.

APPENDIXES

A. CLASSIFICATION OF SELECTED SCENES IN OLD KINGDOM PRIVATE TOMBS

Numbers refer to pages

SUMMARY OF SECTIONS

Division into sections retained from *Bibl.* iii², Part 1

- | | |
|--|---|
| 1. Deceased and family in marshes | 8. Marsh-scenes |
| 2. Palanquin scenes | 9. Crafts |
| 2A. Deceased painting seasons | 10. Baking and cooking |
| 2B. Deceased and wife playing draughts | 11. Brewing |
| 3. Agriculture | 12. Music, singing, and games |
| 3A. Gardening | 13. Funerary scenes and rites |
| 3B. Poultry-yard | 14. Estates |
| 4. Vintage | 15. Special or less common scenes |
| 5. Herdsmen and herds | 16. Special or unusual people |
| 6. Rendering accounts | 17. Less common animals, birds, and insects |
| 7. Butchers | |

1. Deceased and family in marshes

- (a) **Fowling**
467 (7), 495 (2), 520 (2), 522 (13), 526 (12), 583 (2), 595, 596, 616 (2), 620 (5), 628 (5), 631 (12), 634 (6)–(7), 639 (4), 642 (4), 643 (22), 644 (4), 645 (3), 646, 696, 891, 891.
- (b) **Spearing fish**
518 (3), 522 (13), 527 (15), 583 (2), 594 (8), 595, 596, 614 (4), 616 (2), 620 (7), 624 (2), 626 (4), 631 (12), 634 (6)–(7), 642 (4), 643 (22), 644 (4), 645 (3), 891, 891. The same, but not performed by the tomb-owner, 534 (81), 639 (4).
- (c) **Pulling papyrus from raft**
471 (23), 534 (81).
- (d) **Other or unspecified activities**
476 (45), 522 (9), 617 (2) and (4), 624 (4).

2. Palanquin scenes

- (a) **Deceased in palanquin**
460 (3), 470 (6)–(7), 496 (13), 497 (2), 520 (3), 523 (22), 532 (74), 535 (108), 536 (115), 536 (116)–(117), 596, 603 (20), 643 (18), 647, 671, 891, 891. On donkeys, 642 (11).
- (b) **Men or women carrying empty palanquin**
527 (14), 535 (94).

2A. Deceased painting seasons

509 (13), 526 (10).

2B. Deceased and wife playing draughts

533 (79).

3. Agriculture

- (a) **General**
Including ploughing, hacking ground, issuing seed, sowing, animals treading grain, reaping corn, binding sheaves, filling and tying sacks with sheaves, bringing donkeys, donkeys carrying produce, heaping sheaves, threshing with donkeys, sheep, or cattle, piling up, sifting, winnowing and measuring corn, filling granaries, stacking straw. Flute-player, singer, and men with resonant sticks in harvest scenes, *see* Sect. 12a.
447 (4), 454 (2), 467 (2), 472 (34), 476 (46), 481 (2), 486 (2), 487 (2), 491 (3), 494, 496 (13), 498, 512 (2), 533 (80), 546, 569, 578, 584 (8), 585, 594 (7), 595, 597 (15), 599 (4), 620 (9), (10), and (13), 623 (6), 624 (3) and (9), 628 (9), 635 (3), 637 (2), 640 (1)–(2), 643 (17) and (18), 644 (2), 645 (2), 647, 654, 671, 694, 699 (2), 753, 755, 756, 758, 891.
- (b) **Flax-harvest**
Including pulling flax and tying up bundles.
454 (2), 467 (2), 472 (34), 496 (13), 520 (8), 533 (80), 578, 584 (8), 594 (7), 628 (9), 635 (3), 643 (18), 644 (2), 645 (2), 694, 699 (2), 755.
- (c) **Various**
Picking fruit (mostly figs), 495 (7)–(8), 525, 533 (78), 584 (7), 616, 620 (14), 624 (6), 637 (2), 642 (10). Catching birds (not the same as netting fowl in marshes, Sect. 8e), including putting birds into cages, 473 (36), 495 (9), 533 (78) and (80), 546, 584 (7), 594 (6), 635 (3), 637 (2), 642 (7). Felling trees, including carrying and dressing logs, 628 (10), 640 (3), 642 (7). Filling water-pool, 628 (10).

3A. Gardening

527 (13), 616, 622 (31), 637 (2), 642 (7), 694.

3B. Poultry-yard

Including scenes of feeding fowl.

469 (1), 470 (10), 516 (9), 518 (4), 523 (20), 529 (33), 536 (117), 631 (8), 750.

4. Vintage

Including watering, picking grapes, bringing baskets of grapes, treading grapes and pressing must, filling and sealing wine-jars, but omitting bringing wine. Men with resonant sticks, *see* Sect. 12a.

473 (36), 495 (7)-(8), 531 (66), 584 (7), 599 (1)-(2), 601 (17), 624 (7), 628 (10), 637 (2), 640 (1)-(2), 642 (7), (9), and (10), 750.

5. Herdsmen and herds

Butchers, *see* Sect. 7.

(a) General

Mostly cattle, but also goats. Including feeding, milking, calving, cow suckling calf, bull mounting cow, men overthrowing bull and lassoing cow. Omitting scenes of bringing cattle, etc.

454 (1), 467-8 (8), 469 (1), 470 (9), 475 (44), 476 (46), 488 (6), 494, 495 (10), 518 (4), 520 (4), 522 (12), 523 (20), 535 (93), 570, 575 (3), 594 (6) and (8), 599 (1)-(2), 599 (6), (7), and (10)-(11), 602 (18), 607 (3), 608, 614 (3), 617 (7), 620 (8), 624 (9) and (11), 631 (6), 635 (2) and (3), 637 (1), 640 (1)-(2), and (3), 642 (7), 643 (22), 644 (5), 646, 653 (3), 753, 754, 754, 761.

(b) Crossing water

Including herdsmen in papyrus rafts reciting charm against crocodiles.

438, 467 (8), 475 (44), 476 (46), 482 (5), 487 (7), 494 (1), 495 (2), 512 (2), 520 (4), 522 (12), 527 (13), 594 (8), 599 (5), 601 (17), 617 (7), 620 (13), 635 (2), 639 (4), 640 (1)-(2), 643 (22), 646, 758, 892.

(c) Cooking or drinking

454 (1), 575 (3), 594 (8), 640 (1)-(2), 643 (22), 644 (5), 754.

(d) Mat making

475 (44), 522 (12), 594 (8), 643 (22), 644 (5), 754. *See also* Sect. 9h.

(e) Special details

Skinning goat, 640 (1)-(2). Feeding puppy, 522 (12).

6. Rendering accounts by chiefs of estates, herdsmen, etc.

461 (1), 467 (2), 474 (37), 484 (5), 486 (2), 495 (10) and (11), 509 (15), 518 (4), 522 (11), 528 (23), 617 (3), 618 (8), 631 (13), 635 (3), 637 (1), 640 (1)-(2), 643 (17), 645 (2), 699 (2), 756.

7. Butchers

447 (1), 448 (7), (9), (10), (12), and (13), 454 (1) and (3), 455, 455 (2), 456 (6), 460 (3), 461 (6) and (7), 468 (8), 468, 470 (4), 471 (24), 475 (38) and (41), 481, 481 (1), 483, 483, 484 (6) and (7), 485 (6) and (7), 486 (1), 487 (1), 488 (5), 492 (7), 493 (3), 495 (12), 497 (4), 498, 499, 506, 510 (30) and (36), 513 (16), 516 (11), 518, 518 (9), 519 (2)-(3), 520 (8), 524 (35), 529 (35) and (39), 531 (62), 535 (97) and (109), 536 (121), 539, 541, 558, 569, 570, 575 (3), 576 (5), 577, 579, 581, 581 (5), 582 (5), 583 (3), 594 (7) and (8), 595, 596, 597 (15), 599 (7), 600 (16), 603 (19), 607 (5), 609, 609, 614 (2), 615 (3), 616 (12), 618 (20), 619 (21) and (24), 621 (17), (19), and (25), 625 (21) and (23), 627 (2), 628 (8), 629 (16), 631 (18), 634 (6)-(7), 634 (1), 636 (5), 639 (2)-(3), 640 (4), 642 (2) and (3), 642 (4), 644 (25) and (26), 646, 653 (7), 671, 696, 696, 699 (4) and (6), 762, 827, 891, 891.

8. Marsh-scenes

Deceased fowling, fishing, etc., *see* Sect. 1. Herdsmen with cattle crossing water, *see* Sect. 5b.

(a) Papyrus harvest, with men pulling or carrying bundles of papyrus

443, 467 (7), 476 (46), 494, 599 (6), 601 (17), 617 (7), 623 (5), 628 (9) and (10), 635 (2), 637 (2), 640 (1)-(2), 644 (3) and (5), 695.

(b) Making papyrus-rafts (sometimes with men making ropes)

467 (7), 476 (46), 522 (12), 594 (8), 599 (6), 601 (17), 613, 617 (7), 628 (9), 635 (2), 640 (1)-(2), 644 (3) and (5), 695, 761.

(c) Netting fish

468 (8), 475 (44), 482 (5), 487 (7), 492 (4), 498, 501 (1), 520 (4), 522 (9), 523 (21), 529 (26) and (36), 535 (93), 569, 583 (2), 585, 594 (8), 607 (4), 616 (4)-(5), 617 (4), 620 (13), 627 (3), 628 (9), 631 (1), 635 (2), 639 (4), 640 (1)-(2), 642 (9), 644 (4), 695, 700 (8), 754, 891. With small net/hand-net/dip-net/clap-net, 467 (7), 522 (13), 529 (26), 599 (5), 605, 617 (2), (4), and (7), 642 (9); with baskets, 469 (1), 476 (46), 523 (21), 529 (26), 642 (9), 753. Spearing fish, *see* Sect. 1b.

(d) Angling

476 (45), 515 (6), 522 (9) and (13), 529 (26), 594 (8), 599 (6), 617 (4) and (7).

(e) Netting fowl

Including making/mending and setting up clap-net, waiting for birds to enter net, pulling rope, taking birds out of net and putting into cages, but omitting men bringing fowl. 454 (2), 468 (8), 475 (44), 482 (5), 484, 488 (5), 492 (4), 513 (8), 516 (9), 523 (20), 579, 583 (2), 585, 594 (8), 597 (15), 599 (3), 601 (17), 614 (3), 619 (3), 620 (13), 623 (5), 635 (2), 639 (4), 640 (1)-(2), 642 (9), 644 (5), 646, 699 (2), 754, 892.

- (f) **Hippopotamus-hunt**
476 (45), 494, 522 (13), 527 (15), 579, 617 (7), 635 (2).
- (g) **Boatmen jousting**
454 (2), 467 (8), 476 (46), 570, 594 (8), 599 (5), 601 (17), 606 (1), 614 (3), 618 (17), 635 (2), 640 (1)-(2), 643 (22), 695, 753, 753.
- (h) **Various**
Cutting out roes of fish/cutting open fish/preparing botargo, 475 (44), 482 (5), 488 (6), 492 (4), 498, 518 (7), 523 (21), 583 (2), 594 (8), 601 (17), 607 (3), 608, 628 (9), 631 (5), 635 (2), 644 (3), 695, 753, 754. Fishing from boats (unspecified), 623 (5). Unloading fish, 891. Plucking lotus-flowers from rafts, 614 (3).
- (i) **Unspecified**
Could also be Sect. 1.
509 (22), 519 (2)-(3), 608, 616 (13).

9. Crafts

- (a) **Metal-workers**
Including men with blowpipes, weighing, beating metal, pouring molten metal into mould, etc.
473 (36), 484 (5), 486 (2), 513 (7), 522 (14), 528 (20), 620 (11), 631 (9), 643 (19).
- (b) **Carpenters**
Including bending poles, sawing, making bed, coffin, door-bolt, wooden column, etc.
473 (36), 484 (5), 486 (2), 528 (20), 640 (3), 643 (19), 891.
- (c) **Boat-builders**
471 (26)-(27), 473 (35), 495 (6), 532 (76), 640 (3), 642 (7). Making papyrus-rafts, *see Sect. 8b.*
- (d) **Jewellers (usually dwarfs)**
486 (2), 513 (7), 528 (20), 600 (16), 631 (9), 640 (1)-(2), 643 (19).
- (e) **Leather-workers**
473 (36), 513 (7).
- (f) **Makers of stone vessels**
473 (36), 486 (2), 499, 513 (7), 528 (20).
- (g) **Sculptors**
473 (36), 486 (2), 513 (7), 528 (20), 631 (9), 643 (19). *See also Sect. 13c.*
- (h) **Others**
Pottery-making, 472 (32), 496. Seal-maker, 473 (36). Mat-making, 498; *see also Sect. 5d.* Spinning, 546. Unspecified, 754.

10. Baking and cooking

Herdsmen cooking, *see Sect. 5c.*

- (a) **Bread or cakes**
Also preparing for brewing. Including issuing corn, grinding corn on quern, sifting flour, kneading dough, shaping loaves, heating pots, pouring dough into pots, testing bread with stick, and baking cakes on fire.
472 (32), 486 (2), 488 (6), 498, 509 (15),

512 (5), 583 (2), 584 (8), 594 (5), 616 (1), 620 (8), 642 (6), 753, 753, 760.

- (b) **Fowl or meat**
Including plucking, cleaning, cooking, or roasting fowl, and cutting up and cooking meat.
448 (11), 488 (5), 516 (9), 594 (7), 607 (3), 620 (8), 628 (7), 631 (5).
- (c) **Unspecified**
443, 483 (1), 605, 760.

11. Brewing

Baking bread, *see Sect. 10a.* Including grinding corn in mortar, treading pieces of bread in vat, straining beer, cleaning, filling, and sealing beer-jars.

472 (32), 486 (2), 488 (6), 509 (15), 510, 512 (5), 594 (5), 620 (8), 642 (6), 745, 753.

12. Music, singing, and games

- (a) **Musicians (mainly flutists and harpists), including scenes with wife or daughter playing the harp, and singers**
471 (25), 475 (38), 486 (4), 488, 495 (7)-(8), 498, 501 (4), 530 (50), 541, 580 (4), 582 (6), 584 (6), 585, 594 (7), 600 (16), 607 (4), 614 (3), 616 (6), 621 (17), 623, 628 (7), 631 (7), 636 (5), 640 (5), 643 (20), 644 (7), 646, 697, 699 (6), 761, 762, 891. Flute-player in harvest-scene, 533 (80), 584 (8), 620 (10), 694; with singer, 472 (34). Men with resonant sticks in harvest-scene, 584 (8); in vintage-scene, 531 (66), 637 (2), 640 (1)-(2), 750.
- (b) **Male or female dancers/acrobats and/or clappers**
471 (25), 487 (2), 488, 495 (7)-(8), 498, 514 (23), 522 (15), 530 (53), 535 (100), 577, 579, 580 (4), 584 (6), 585, 605, 607 (4), 621 (17), 628 (7), 636 (5), 640 (1)-(2), 643 (20), 699 (6), 891. Female clappers and dancers in funeral-scene, *see Sect. 13d*; mirror-dance, *see Sect. 12d.*
- (c) **Playing *mehen*-game (snake-game) and/or *senet*-game (draughts)**
495 (7)-(8), 496, 498, 584 (6), 585, 628 (7), 631 (7).
- (d) **Children playing games**
Including mirror-dance.
498, 509 (16), 533 (78), 595 (8), 601 (17), 602 (18).

13. Funerary scenes and rites

- (a) **Coffin or sarcophagus**
Carried or dragged, 514 (22), 532 (70), 605, 618 (9), 628 (8), 891. Transported in boat, 532 (70), 618 (9), 628 (8), 653 (4)-(5), 891. Men before canopy with coffin(?), 653 (4)-(5).
- (b) **Chest(s) with feathers on top**
619, 653 (4)-(5); being dragged, 524 (30) and (32), 599 (7), 616 (3), 623 (6), 642 (5).

(c) Statue(s) of deceased

Dragged to tomb (but also in connection with sculptors), including censings, 447 (1), 460 (3), 471 (24), 487 (1), 495 (9), 523 (18), 528 (20), 583 (1), 593 (2) and (3), 605, 616 (3), 617 (5), 627 (2), 634 (1), 642 (2), (3), and (5), 654 (9), 695. Transported in boat, 470 (4), 593 (3), 642 (2) and (3). Offering to, sometimes with censings, 508 (12), 519 (4), 528 (24), 531 (54), 642 (2) and (3). Others, 452.

(d) Dancers and clappers

Dancers, 605, 618 (9), 628 (8); accompanying statues, 634 (1). Female dancers and clappers, 532 (70), 593 (3), 653 (4)-(5).

(e) Buildings

Purification-tent or embalming house, 532 (70), 628 (8), 891. House of deceased, 514 (22). Tomb, 532 (70).

14. Estates

Concordance with H. K. Jacquet-Gordon, *Les Noms des domaines funéraires sous l'Ancien Empire égyptien* (1962). The list includes estates in royal complexes, on other monuments, or named only, and all those in Part 1 of *Top. Bibl.* iii².

| <i>Jacquet-Gordon</i> | <i>Bibl.</i> iii ² | <i>Jacquet-Gordon</i> | <i>Bibl.</i> iii ² |
|-----------------------|--------------------------------|-----------------------|--------------------------------|
| 1 R 4 | 877 | 24 G 5 | 142 (2) (= upper half of page) |
| 1 R 5 | 398 | 25 G 5 | 144 (6) |
| 2 R 5 | 330 (16), 332 | 26 G 5 | 208 (4)-(5) |
| 3 R 5 | 873 | 27 G 5 | 52 |
| 4 R 5 | 337 | 28 G 5 | 66 |
| 5 R 5 | 314 | 29 G 5 | 266 (6), 267 |
| 6 R 5 | 424 | 30 G 5 | 154 (6) |
| 7 R 5 | 418 | 31 G 5 | 171 (5) |
| 1 R 6 | 426 (5) and (6) | 32 G 5 | 190 (3) |
| 1 A 4 | 7 | 33 G 5 | 283 (1) and (2) |
| 1 G 4 | 134 | 34 G 5 | 263 (7), 264 (8) |
| 2 G 4 | 189 (7) and (9) | 35 G 5 | 206 (2) |
| 3 G 4 | 196 (2) | 36 G 5 | 205 |
| 4 G 4 | 194 | 37 G 5 | 245 |
| 5 G 4 | 139 | 38 G 5 | 86 (8) and (13) |
| 6 G 4 | 140 | 39 G 5 | 88-9 (8) |
| 7 G 4 | 204 (2) and (3) | 40 G 5 | 95 (3) |
| 8 G 4 | 202 (3) | 41 G 5-6 | 164 (3) |
| 9 G 4 | 232 (3) | 42 G 6 | 102 (3) |
| 10 G 4 | 198 (9) | 43 G 6 | 225 (15) |
| 11 G 4-5 | 234 (3) | 44 G 6 | 87 |
| 12 G 4-5 | 231 (4), 232 (8) | 45 G 6 | 227 |
| 13 G 4-5 | 71 (3) | 46 G 6 | 51 (1) and (2) |
| 14 G 4-5 | 244 (1) | 47 G 6 | 149 (3) |
| 15 G 4-5 | 256 (2) | 48 G 6 | 167 |
| 16 G 4-5 | 219 | 49 G 6 | 106 (2) |
| 17 G 4-5 | 145 | 50 G 6 | 179 |
| 18 G 5 | 142 (2) (= lower half of page) | 1 S 4 | 493 (1) |
| 19 G 5 | 77 (2)-(3) | 2 S 4 | 453 (4) |
| 20 G 5 | 146 (9) | 3 S 4 | 453 (5) |
| 21 G 5 | 278 | 4 S 4 | 502 (3) and (4) |
| 22 G 5 | 78 (3)-(4) | 5 S 4 | 443 |
| 23 G 5 | 150 (6) | 6 S 5 | 694 |
| | | 7 S 5 | 578 |
| | | 8 S 5 | 582 (2) |
| | | 9 S 5 | 580 (2) and (3) |
| | | 10 S 5 | 483 (1) |
| | | 11 S 5 | 583 (1) |
| | | 12 S 5 | 637 (5) |
| | | 13 S 5 | 488 (1) and (3) |
| | | 14 S 5 | 652 |
| | | 15 S 5 | 487 (2) |
| | | 16 S 5 | 608 |
| | | 17 S 5 | 469 (1), 477 (44)-(46) |
| | | 18 S 5 | 491-2 (3) and (4) |
| | | 19 S 5 | 495 (6) |
| | | 20 S 5 | 455 (2) |
| | | 21 S 5 | 497 (3) |
| | | 22 S 5 | 693 |
| | | 23 S 5 | 692 |
| | | 24 S 5 | 597 (16) and (17) |
| | | 25 S 5 | 599 (1)-(2) and (5)-(6) |
| | | 26 S 5 | 623 (4) |
| | | 27 S 5 | 763 |
| | | 28 S 5-6 | 603 (19) |
| | | 29 S 5-6 | 652 |
| | | 30 S 6 | 627 (2) |
| | | 31 S 6 | 595 |
| | | 32 S 6 | 512 (3) |
| | | 33 S 6 | 543 |
| | | 34 S 6 | 491 |
| | | 35 S 6 | 529 (32) |

| | |
|-----------------------|-------------------------------|
| <i>Jacquet-Gordon</i> | <i>Bibl. iii</i> ² |
| 36 S 6 | 535 (99) |
| 37 S 6 | 460 (3) |
| 38 S 6 | 620 (10) |
| 39 S 6 | 615 (1) |
| 40 S 6 | 631 (2) |
| 1 D 4 | 894 |
| 2 D 4 | 880 |
| 3 D 5 | 894 |
| 4 D 6 | 891 |

Others (mostly no names), 74 (5), 75 (3), 96 (1), 136 (3), 186 (5), 192 (5), 255 (6) and (7), 263 (5), 264 (10) and (11), 493 (5), 585, 614 (3), 624 (10), 642 (11), 643 (19), 678.

15. Special or less common scenes

Hunting-scene, 473 (35), 487 (3), 491 (4), 493 (4), 528 (18), 536 (112), 599 (1)-(2), 601 (17), 605, 619, 628 (10), 642 (10). Rewarding scene, 647; rewarding weavers with jewellery, 634 (1), 653 (1); putting necklaces in boxes, 496 (13). Servants preparing bed, 530 (51), 607 (3), 616 (10), 621 (16), 624 (16), 639 (1), 645 (1), 752, 891; and chair, 699 (2). Market-scenes, 473 (36), 484 (5), 512 (6), 523 (22), 642 (7). Surgical operations, 514 (21). Circumcision, 514 (21). Manicure and pedicure, 509 (16), 642 (7). Fattening hyenas, 523 (20), 532 (76). Inspection of linen, 496. Boat or raft transporting cattle, 593 (4), 618 (15); corn, 623 (6); oils, 642 (10). Men tied to whipping-post, 509 (15), 528 (23). Siege of a fortified settlement, 542 (5).

16. Special or unusual people

Barbers, 642 (7). Fishmonger, 642 (7). Swimmers, 532 (70). Dwarfs with dog(s) and/or monkey, 470 (6)-(7), 475 (44), 501 (4), 513 (8), 523 (22), 532 (74), 584 (8), 696, 696; as attendant, 624 (8); with box, 510 (38), 518 (3); holding palette, 640 (4); making jewellery, *see* Sect. 9d.

17. Less common animals, birds, insects

Only when specifically mentioned in the text. Baboon, 460 (3), 484 (5), 613, 640 (1)-(2) and (3). Civet-cat, 619. Eel, 608. Frog, 527 (12), 583 (2). Grasshopper, 527 (12). Hare, 473 (35), 576 (4). Hedgehog, 515 (7), 519 (8). Hoopoe, 481, 593 (1). Hyena, 523 (20), 532 (76), 602 (18). Ichneumon, 526 (12), 527 (15), 579, 594 (8), 620 (5), 623 (5). Leopard, 602 (18). Lion, 473 (35), 519 (8), 536 (112), 602 (18), 605. Monkey, 501, 513 (8), 523 (22), 529 (27), 535 (108), 600 (16), 640 (3), 693, 696, 696, 891. Moufflon, 621 (18). Otter, 534 (81). Panther, 696. Turtle, 620 (13). Wild dog, 601 (17).

B. CLASSIFICATION OF SELECTED OLD KINGDOM TEXTS

I. Texts in K. Sethe, Urkunden des Alten Reichs (1933)

| <i>Urk. i</i> | <i>Present location</i> | <i>Page</i> |
|------------------|--|-------------|
| 1-6 [1, A-E] | Şaqqâra Tomb LS 6 | 493-4 |
| 6-7 [1, F] | Berlin (West) Mus. 1106 | 493 |
| 10 [8] | Cairo Mus. CG 1566 | 693 |
| 33 [19, A] | Cairo Mus. CG 1415 | 484 (4) |
| 33 [19, B] | Cairo Mus. CG 1417 | 483 (2) |
| 33-4 [20] | Şaqqâra Tomb C 25 | 690 |
| 34 [21] | Cairo Mus. CG 1691 | 693 |
| 34-5 [22] | Şaqqâra Tomb No. 83 [D 6; S 907] | 488 (2) |
| 36-7 [24] | Şaqqâra Tomb D 52 | 582 |
| 37 [25] | Berlin (East) Mus. 15004 | 578 |
| 38-40 [26, A, B] | Cairo Mus. CG 1482 | 482-3 |
| 40-5 [27] | Cairo Mus. CG 1569, 1674, 1570, 1673, 1702, JE 55937 | 456 |
| | Aberdeen Mus. 1558a, b, c, 1560 | |
| 48-9 [30, A, B] | Şaqqâra Tomb D 70 [LS 15] | 492 (5) |
| 49-51 [31] | Leyden Mus. F.1904/3/1 | 593 (1) |
| 51-3 [32, A, B] | Brit. Mus. 682 | 464 |
| 58 [40] | Cairo Mus. CG 1461 | 468 |

| <i>Urk. i</i> | <i>Present location</i> | <i>Page</i> |
|------------------------|---|-----------------------------------|
| 58 [41] | Cairo Mus. CG 1308 | 462 |
| 68-9 [45] | Şaqqâra Tomb No. 75 [D 10] | 483 |
| 73 [50] | Cairo Mus. CG 376 | 722 |
| 75 [1] | Cairo Mus. CG 1732 | 611 |
| 80 [4] | Şaqqâra Tomb D 65 | 606 |
| 81 [5, A, B] | Şaqqâra Tomb of Ptahshepses [II] | 460 (1) |
| 82-4 [5, C, D] | Cairo Mus. CG 1565 | 460 (4) |
| 84-5 [6] | Cairo Mus. CG 1709, 1756 | 463 |
| 87-8 [8, A] | Şaqqâra Tomb of Mereruka | 526 (10) |
| 88 [8, B] | Şaqqâra Tomb of Mereruka | 532 (70) |
| 97 [15, C] | Berlin (East) Mus. 7715 | 423 |
| 97 [16] | Cairo Mus. | 424 |
| 153 [I (92)] | Cairo Mus. JE 49889 | 407 |
| 173-4 [19 (110), A] | Şaqqâra Tomb No. 60 [D 22] | 469 (1) (e) |
| 174 [19 (110), B] | Şaqqâra Tomb No. 60 [D 22] | 469 (1) (f) |
| 175 [20 (111), A, B] | New York, M.M.A. 26.9.1 | 541 |
| 176 [20 (111), C, D] | Şaqqâra Tomb of Kaemsenu | 541 |
| 177 [21 (112), A] | Şaqqâra Tomb of Sekhemka | 596 |
| 177 [21 (112), B] | Philadelphia Mus. E 15729 | 455-6 (5) |
| 177 [21 (112), C] | Cairo Mus. CG 1565 | 460 (4) |
| 178 [21 (112), D] | Cairo Mus. CG 1421 | 468 |
| 179-80 [24 (115)] | Şaqqâra Tomb LS 16 [S 902] | 496 |
| 180-6 [25 (116), A-E] | Şaqqâra Tomb No. 84 [D 7; S 919] | 489 (1), (5), (6), (3) and (4) |
| 188-9 [28-9 (119-20)] | Şaqqâra Tomb of Ptahhotp [II] | 604 (20) |
| 190-1 [30 (121)] | Şaqqâra Tomb No. 75 [D 10] | 483 |
| 191-2 [31 (122) A, B] | Şaqqâra Tomb No. 14 [D 43] | 452 |
| 192 [31 (122), C] | Brooklyn Mus. 37.25E | 452 |
| 192-3 [31 (122), D, E] | Brooklyn Mus. 37.27-8E | 452 |
| 193 [32 (123)] | Şaqqâra Tomb of Seshemnûfer | 615 (6) |
| 194-6 [33 (124), A-D] | Şaqqâra Tomb LS 10 | 521 (5) and (6) |
| 197 [34 (125)] | Unknown | 546 |
| 198 [35 (126)] | Unknown | 546 |
| 198-200 [36-7 (127-8)] | Şaqqâra Tomb of Neferseshemrê Sheshi | 512 (6) |
| 200-1 [38 (129)] | Şaqqâra Tomb of Uzahateti Neferseshemtah | 515 |
| 201-3 [39 (130), A, B] | Şaqqâra Tomb of 'Ankhmaḥor | 512 (1) |
| 203 [39 (130), C] | Şaqqâra Tomb of 'Ankhmaḥor | 513 (12) |
| 203 [39 (130), D] | Şaqqâra Tomb of 'Ankhmaḥor | 514 (20) |
| 204-5 [41 (132), A] | Şaqqâra Tomb of 'Ankhmaḥor | 515 |
| 205 [41 (132), B] | Şaqqâra Tomb of Khentka Ikhekhi | 511 |
| 206-7 [42 (133)] | Cairo Mus. JE 47749 | 543 |
| 209-13 [45 (136)] | Berlin (East) Mus. 17500 | 876 |
| 227 [5 (145), A] | Brit. Mus. 1324 | 893 |
| 227 [5 (145), B] | Manchester Mus. 10780 | 745 |
| 228 [5 (145), E] | Cairo Mus. CG 394 | 736 |
| 228 [5 (145), F] | Cairo Mus. CG 1365 | 768 |
| 235-49 [10 (150)] | Palermo Mus. and Cairo Mus. CG 39734-5, 44859-60 | 873 |
| 249-50 [11 (151)] | Unknown | 547 |
| 255-6 [14 (154)] | Brussels, Mus. Roy. E.2243 | 694 |
| 260 [18 (158)] | Leipzig Mus. Inv.359 | 686 |
| 262 [19 (159), C] | Şaqqâra tomb-group N. IV | 677 |
| 271-2 [26 (166), A] | Pyramid-enclosure of Iput II | 432 |
| 272 [26 (166), B] | Pyramid-enclosure of Wezebtan | 433 |
| 272-3 [27 (167), A] | Cairo Mus. JE 49681 | 432 |
| 273-4 [27 (167), B, C] | Pyramid-enclosure of Wezebtan | 433 |
| 307 [38 (178)] | Cairo Mus. JE 56370 | 431 |









II. Other Old Kingdom texts

| | |
|---|--|
| Address, 508 (7)-(9), 519, 520, 570, 609, 610, 623, | Biographical text, 508 (10), 569, 605, 626 (3), 625 (1), 626, 626 (3), 630, 646, 763. |
| Appointment as <i>ka</i> -servant, 674. | Contract with funerary priests, 642 (8). |

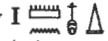
| | |
|---|---|
| Cryptographic offering-text, 754. | Purchase of tomb, 652. |
| Decree, 395, 433, 684. | Pyramid-texts (Old Kingdom only), 396, 421, 423, 425, 425, 430, 432, 433, 750, 751. |
| Graffiti (other than mason's), 424, 428, 510 (41), 521, 522. | Rewarding craftsmen, 646. |
| Linen account, 641. | Shepherd's song, 454 (2), 476 (46), 533 (80), 620 (13), 624 (9), 654. |
| Love-poem, 535 (100). | Threat, 630. |
| Mason's graffiti and marks, 393, 399, 400, 417, 421, 425, 434, 497, 576 (6), 579, 633, 876, 881, 882. | Will, 628 (6). |
| Mortuary endowment, 652. | Wisdom text, 646. |
| | Unclassified, 604. |

C. PYRAMIDS

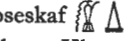
in this volume

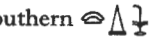
| | | <i>Lepsius</i> ¹ | <i>Perring</i> ² <i>and Vyse</i> | | <i>Page</i> |
|--|----------------------|-----------------------------|--|--|-------------|
| ŠAQQĀRA | | | | | |
| Teti  | Dyn. VI | XXX | 1 | | 395 |
| Iput I | | | | | 396 |
| Khuit | | | | | 397 |
| Userkaf  | Dyn. V | XXXI | 2 | el-Haram | 398 |
| | | | | el-Makharbish | |
| Neterikhet (Zoser) | Dyn. III | XXXII | 3 | el-Haram | 399 |
| | | | | el-Mudarrag | |
| Sekhemkhet | Dyn. III | | | | 416 |
| ? ('Great Enclosure') | probably Dyn. III | | | | 417 |
| Unis  | Dyn. V | XXXV | 4 | | 421 |
| Pepy I  | Dyn. VI | XXXVI | 5 | | 423 |
| Isezi  | Dyn. V | XXXVII | 6 | Haram el-Shawwâf | 424 |
| Probably wife of Isezi | Dyn. V | XXXVIII | 7 | | 424 |
| Merenrē I  | Dyn. VI | XXXIX | 8 | | 425 |
| Ķakarē Ibi | Dyn. VIII | XL | | | 425 |
| Pepy II  | Dyn. VI | XLI | 9 | | 429 |
| Neit | | | | | 431 |
| Iput II | | | | | 432 |
| Wezebtan | | XLII | | | 433 |
| Shepseskaf  | Dyn. IV | XLIII | | Maštabet Fara'ûn | 434 |
| Userkarē Khenzer | Dyn. XIII | XLIV | | | 434 |
| ? | Dyn. XIII | XLVI | | | 435 |
| DAHSHÛR | | | | | |
| Snefru  | Dyn. IV | | | | |
| Northern | | XLIX | | Red | 876 |
| Southern  | | LVI | | Blunted, Bent, False, or Rhomboidal | 881 |
| Subsidiary | | LVII | | | 882 |
| Sesostris III | Dyn. XII | XLVII | | | 882 |
| Amenemhēt II | Dyn. XII | LI | | White | 886 |
| ? | Dyn. XIII | LIV | | | 887 |

¹ 'Pyramids' XXXIII and XXXIV are the North and South Buildings in the Step Pyramid Enclosure, p. 412, XLVIII is the easternmost of the South Mastabas in the Pyramid-complex of Sesostris III, p. 885, LV is the tomb of Siēsi, p. 898. Pyramids XXIX, XLV, L, LII, and LIII have been omitted here.

² Numbering of the Šaqqāra pyramids.

| | | <i>Lepsius</i> | <i>Perring and Vyse</i> | <i>Page</i> |
|---------------|-----------|----------------|-----------------------------|-------------|
| Amenemhêt III | Dyn. XII | LVIII | Black | 887 |
| ? | Dyn. XIII | | | 890 |
| ? | Dyn. XIII | | | 890 |
| Ameny-Ḳemau | Dyn. XIII | | | 890 |

D. NUMBERED ŞAQQÂRA TOMBS

in this volume

Approximate location of tombs marked 'Position unknown' is in some cases indicated by headings in the text

(a) *Mariette and de Morgan*

| <i>No.</i> | <i>Position on map</i> | <i>Page</i> | <i>No.</i> | <i>Position on map</i> | <i>Page</i> |
|------------|-------------------------------|---------------------------|---------------|--|---------------------------|
| 1 | XLV, B-1 | 448 | 47 | XLVI, D-2 | 463 <i>and</i> Addenda |
| 2 | XLV, B-1 | 449 | 48 | XLVI, D-2 | 464, 465 <i>note</i> 1 |
| 3 | XLV, B-1 | 449 | 49 | XLVI, D-2 | 464, 505, 583 |
| 4 | XLV, C-1 | 449 | 50 | XLVI, D-2 | 464 |
| 5 | XLV, C-3 | 449 | 51 | XLVI, D-2 | 465 |
| 6 | XLV, B-3 | 450 | 52 | XLVI, D-2 | 465 |
| 7 | XLV, B-2 | 450 | 53 | XLVI, D-2 | 465 |
| 8 | XLV, B-2 | 451 | 54 | XLVI, D-2 | 465 |
| 9 | XLV, B-2 | 451 <i>and</i> Addenda | 55 | XLVI, D-2 | 466 |
| 10 | XLV, B-3 | 451 | 56 | XLVI, D-2 | 466 |
| 11 | XLV, B-2 | 451 | 57 | XLVI, D-1 | 467 |
| 12 | XLV, B-3 | 451 | 58 | XLVI, D-1 | 468 |
| 13 | XLV, B-3 | 451 | 59 | XLVI, D-1 | 468 |
| 14 | XLV, B-3 | 452 <i>and</i> Addenda | 60 | XLVI, D-1 | 468, 507 |
| 15 | XLV, B/C-3 | 452 | 61 | XLVI, D-1 | 478 |
| 16 | XLVI, D-2 | 453 | 62 | XLVI, D-1 | 478 |
| 17 | identification not certain | | 63 | XLVI, D-1 | 479 |
| 18 | XLV, C-3 | 453 | 64 | XLVI, D-1 | 479 |
| 19 | XLV, C-1 | 453 | 65 | XLVI, D-2 | 480 |
| 20 | XLV, C-1 | 454 | 66 | XLVI, D-2 | 457 <i>note</i> 1, 480 |
| 21 | XLV, C-1 | 455 | 67 | XLVI, D-2 | 481 |
| 22 | XLV, C-1 | 455 | 68 | XLVI, D-2 | 481 |
| 23 | XLV, C-1 | 456 | 69 | XLVI, D-2 | 481 |
| 24 | XLV, C-2 | 456 | 70 | XLVI, D-2 | 482 |
| 25 | XLV, C-2 | 456 | 71 | XLVI, D-3 | 482 |
| 26 | XLV, C-2 | 456 | 72 | XLVI, E-3 | 482 |
| 27 | XLV, C-2 | 457 | 73 | XLVI, E-3 | 482 <i>and</i> Addenda |
| 28 | XLV, C-2 | 457 | 74 | XLVI, E-3 | 482 |
| 29 | XLV, C-2 | 457 | 75 | XLVI, E-3 | 483 |
| 30 | XLV, C-2 | 457 | 76 | XLVI, E-3 | 483 |
| 31 | XLV, C-2 | 458 | 77 | XLVI, E-3 | 484 |
| 32 | XLV, C-2 | 458 | 78 | XLVI, E-3 | 485 |
| 33 | XLV, C-2 | 458 | 79 | XLVI, E-3 | 485 |
| 34 | XLV, C-2 | 458 | 80 (probably) | XLVI, E-3 | 487 |
| 35 | XLVI, D-3 | 458 | 81 | XLVI, E-3 | 488 |
| 36 | XLVI, D-2 | 459, 724 | 82 | XLVI, E-3 | 488 |
| 37-8 | XLVI, D-2 | 460 | 83 | XLVI, E-3 | 488 |
| 39 | XLVI, D-2 | 461 | 84 | XLVI, E-3 | 489 |
| 40 | XLVI, D-2 | 461 | 85 | XLVI, E-2 | 489 |
| 41-2 | XLVI, D-2 | 462 | 86 | Galleries in the Step Pyramid Enclosure | 415 |
| 43 | XLVI, D-2 | 463 | 87 | tomb not identified | |
| 44 | XLVI, D-2 | 463 | 88 | unknown | 489 |
| 45 | XLVI, D-2 | 463 | | | |
| 46 | XLVI, D-2 | 463 | | | |

Numbered Şaqqâra tombs

911

(b) Mariette

| No. | Position on map or equation | Page | No. | Position on map or equation | Page |
|-----------|--------------------------------|--------------------|------|--|--------------------|
| A 1 | = No. 18 | 453 | D 11 | = No. 76 | 483 |
| A 2 | = No. 5 | 449 | D 12 | = No. 74 | 482 |
| A 3 | = S 2405 | 437 | D 13 | = No. 73 | 482 and Addenda |
| A 4 | = No. 86 | 415 | D 14 | = No. 70 | 482 |
| B 1 | = No. 71 | 482 | D 15 | = No. 69 | 481 |
| B 2 | unknown | 490 | D 16 | = No. 67 | 481 |
| B 3 | unknown | 490 | D 17 | = No. 65 | 480 |
| B 4 | = No. 9 | 451 and Addenda | D 18 | = No. 64 | 479 |
| B 5 | = No. 1 | 448 | D 19 | = No. 63 | 479 |
| B 6 | = No. 3 | 449 | D 20 | = No. 62 | 478 |
| B 7 | unknown | 490 | D 21 | = No. 61 | 478 |
| B 8 | unknown | 689 | D 22 | = No. 60 | 468, 507 |
| B 9 | = No. 88 | 489 | D 23 | = No. 57 | 467 |
| B 10 | = No. 2 | 449 | D 24 | = No. 56 | 466 |
| B 11 | = No. 4 | 449 | D 25 | = No. 55 | 466 |
| B 12 | = No. 12 | 451 | D 26 | = No. 52 | 465 |
| B 13 | = No. 11 | 451 | D 27 | = No. 53 | 465 |
| B 14 | unknown | 690 | D 28 | = No. 46 | 463 |
| B 15 | XLV, C-1 | 491 | D 29 | = No. 34 | 458 |
| B 16 | = No. 15 | 452 | D 30 | = No. 33 | 458 |
| C 1 | = No. 48 | 464, 465 note | D 31 | = No. 32 | 458 |
| C 2 | = No. 8 | 451 | D 32 | = No. 31 | 458 |
| C 3 | = No. 25 | 456 | D 33 | = No. 30 | 457 |
| C 4 | = No. 68 | 481 | D 34 | = No. 29 | 457 |
| C 5 | = No. 40 | 461 | D 35 | = No. 28 | 457 |
| C 6 and 7 | = Nos. 41-2 | 462 | D 36 | = No. 27 | 457 |
| C 8 | = No. 36 | 459 | D 37 | = No. 26 | 456 |
| C 9 | = No. 50 | 464 | D 38 | = No. 24 | 456 |
| C 10 | = No. 49 | 464, 505, 583 | D 39 | = No. 22 | 455 |
| C 11 | = LS 22 | 579 | D 40 | = No. 21 | 455 |
| C 12 | unknown | 690 | D 41 | = No. 20 | 454 |
| C 13 | = No. 7 | 450 | D 42 | = No. 19 | 453 |
| C 14 | = No. 10 | 451 | D 43 | = No. 14 | 452 and Addenda |
| C 15 | = No. 6 | 450 | D 44 | = No. 13 | 451 |
| C 16 | = No. 39 | 461 | D 45 | LVIII, G-4 | 577 |
| C 17 | = No. 43 | 463 | D 46 | LVIII, F-4 | 577 |
| C 18 | = No. 72 | 482 | D 47 | unknown | 580 |
| C 19 | = No. 54 | 465 | D 48 | LVIII, G-4 | 577 |
| C 20 | = No. 35 | 458 | D 49 | LVIII, G-4 | 578 |
| C 21 | = No. 45 | 463 | D 50 | unknown | 581 |
| C 22 | = No. 51 | 465 | D 51 | unknown | 581 |
| C 23 | = No. 44 | 463 | D 52 | unknown | 582 |
| C 24 | = No. 66 | 457 note 1, 480 | D 53 | unknown | 582 |
| C 25 | unknown | 690 | D 54 | unknown | 582, 464 note 1 |
| C 26 | = LS 20 | 565 | D 55 | unknown | 583 |
| C 27 | unknown | 690 | D 56 | unknown | 584 |
| D 1 | = No. 78 | 485 | D 57 | LVIII, G-4 | 579 |
| D 2 | = No. 79 | 485 | D 58 | unknown | 585 |
| D 3 | = No. 80 | 487 | D 59 | LVIII, F-2 | 595 |
| D 4 | = No. 81 | 488 | D 60 | LVIII, F-1 | 459, 593 |
| D 5 | = No. 82 | 488 | D 61 | LVIII, F-2 | 608 |
| D 6 | = No. 83 | 488 | D 62 | LVIII, F-2 | 596 |
| D 7 | = No. 84 | 489 | D 63 | LVIII, F-2 | 598 |
| D 8 | = No. 85 | 489 | D 64 | LVIII, F-2 | 598 |
| D 9 | = No. 77 | 484 | D 65 | LVIII, F-2 | 606 |
| D 10 | = No. 75 | 483 | D 66 | Sarcophagus- Shaped Tomb of Shepseskaf | 434 |

| No. | Position on map or equation | Page | No. | Position on map or equation | Page |
|--------------|--------------------------------|--------------------|-----------------------|--------------------------------|--------------------|
| D 67 | unknown | 689 | F 4 | = Nos. 41-2 | 462 |
| D 68 | unknown | 689 | H 1 | unknown | 611 |
| D 69 | unknown | 689 | H 2 | = LS 17 | 575 |
| D 70 | XLVI, E-3 | 491 | H 3 | = Nos. 37-8 | 460 |
| E 1, 2 | = Nos. 37-8 | 460 | H 4 (statue) | | 828 |
| E 3 | = No. 47 | 463 and Addenda | H 5 (false- door) | | 466 |
| E 4 | = No. 16 | 453 | H 6 (lintel) | | 762 and Addenda |
| E 5 | = No. 23 | 456 | H 7 (coffin) | | 767 |
| E 6 | = No. 58 | 468 | H 8 (stela) | | 667 |
| E 7 | = No. 59 | 468 | H 9 | unknown | 666 |
| E 8 | LVIII, F-1 | 595 | H 10 (block) | | 753 |
| E 9 | LVIII, F-2 | 596 | H 11 (false- door) | | 483 |
| E 10 | unknown | 585 | H 12 | unknown | 492 |
| E 11 | unknown | 585 | H 13 (false- door) | | 586 |
| E 12 | unknown | 586 | H 14 | = No. 48 | 464 |
| E 13 | unknown | 586 | H 15 (false- door) | | 608 |
| E 14 | unknown | 611 | H 15 (statue) | | 818 |
| E 15 | unknown | 611 | H 16 (coffin) | | 507 |
| E 16 | unknown | 689 | H 17 (coffin) | | 767 |
| E 17 | LXII | 633 | | | |
| F 1 | unknown | 586 | | | |
| F 2 (lintel) | | 753 | | | |
| F 3 | unknown | 586 | | | |

(c) *S* (= *Šaqqāra*) series, used by Quibell, Firth, and Egypt Exploration Society

For another set of Quibell's numbers see Sect. (g)

| No. | Position on map or equation | Page | No. | Position on map or equation | Page |
|---------|--------------------------------|----------|---------|--------------------------------|----------|
| S 901 | = No. 78 | 485 | S 2407 | XLV, B-3 | 439 |
| S 902 | = LS 16 | 494 | S 2427 | XLV, B-3 | 439 |
| S 903 | = No. 80 | 487 | S 2429 | XLV, B-3 | 440 |
| S 905 | = No. 79 | 485 | S 2437 | XLV, B-3/4 | 440 |
| S 906 | XLVI, E-3 | 496 | S 2446 | XLV, B-4 | 440 |
| S 907 | = No. 83 | 488 | S 2452 | XLV, B-3/4 | 440 |
| S 908 | = No. 82 | 488 | S 2466 | unknown | 440 |
| S 909 | XLVI, E-3 | 496 | S 2498 | XLV, B-3/4 | 440 |
| S 910 | = No. 85 | 489 | S 2608 | unknown | 547, 547 |
| S 911 | XLVI, E-3 | 496 | S 2720 | LII | 556, 557 |
| S 912 | XLVI, E-3 | 496 | S 2721 | unknown | 556 |
| S 913 | XLVI, E-3 | 497 | S 2727 | LII | 557 |
| S 915 | XLVI, E-3 | 498 | S 2730 | LII | 555 |
| S 916 | XLVI, E-2 | 498 | S 2734 | LII | 547 |
| S 919 | = No. 84 | 489 | S 2735 | LII | 556 |
| S 920 | XLVI, D-1 | 499 | S 2736 | LII | 555 |
| S 2146E | unknown | 436 | S 2740 | unknown | 547 |
| S 2171 | XLV, B/C-4 | 436, 436 | S 2741 | unknown | 547 |
| S 2171H | XLV, B/C-4 | 436, 436 | S 2745 | unknown | 547 |
| S 2185 | XLV, B/C-4 | 437 | S 2748 | unknown | 547 |
| S 2302 | XLV, B-4 | 437 | S 2757 | LII | 549 |
| S 2305 | XLV, B-4 | 437 | S 3009 | XLV, B-3 | 440 |
| S 2322 | XLV, B-4 | 437 | S 3014 | unknown | 440 |
| S 2331 | XLV, B-4 | 437 | S 3017 | XLV, B-3 | 440 |
| S 2347 | XLV, B-4 | 437 | S 3035 | XLV, A-3/4 | 440 |
| S 2400 | XLV, A-4 | 437 | S 3036 | XLV, A-3 | 442 |
| S 2401 | XLV, A-4 | 437 | S 3036X | XLV, A-3 | 442 |
| S 2405 | XLV, B-3 | 437 | S 3037 | unknown | 442 |

Numbered *Šaqqâra* tombs

913

| No. | Position on map or equation | Page | No. | Position on map or equation | Page |
|---------|--------------------------------|------|--------|--------------------------------|------------|
| S 3038 | XLV, A-3 | 442 | S 3500 | XLV, B/C-4 | 444 |
| S 3038X | = S 3037 | 442 | S 3503 | XLV, C-4 | 444 |
| S 3050 | XLV, A/B-3 | 505 | S 3504 | XLV, C-4/5 | 445 |
| S 3073 | = No. 5 | 449 | S 3505 | XLV, C-5 | 446 |
| S 3073X | unknown | 442 | S 3506 | XLV, C-5 | 446 |
| S 3076 | = No. 18 | 453 | S 3507 | XLVI, D-5 | 447 |
| S 3078 | XLV, C-2/3 | 443 | S 3508 | XLV, C-2 | 447 |
| S 3080 | XLV, C-2 | 443 | S 3509 | XLV, C-2 | 447 |
| S 3111 | XLV, A-3 | 443 | S 3510 | XLV, C-2 | 448 |
| S 3120 | XLV, A-4 | 443 | S 3511 | XLV, C-2 | 448 |
| S 3121 | XLV, A-4 | 443 | S 3513 | XLV, C-2 | 448, 506 |
| S 3302 | unknown | 443 | S 3514 | XLV, C-2 | 448, 506 |
| S 3357 | XLV, B-4 | 443 | S 3516 | XLV, C-2 | 448 note 1 |
| S 3471 | XLV, B-4 | 444 | S 3518 | XLV, B-2/3 | 448 |
| S 3477 | unknown | 444 | | | |

(d) *Lepsius*¹

| No. | Position on map or equation | Page | No. | Position on map or equation | Page |
|--------------------------|--------------------------------|----------|-------|--------------------------------|--------------------|
| LS 4 (Ibis Galleries) | | 821 | LS 19 | LI, F-5 | 566 |
| LS 5 | XLVI, D-2 | 492 | LS 20 | LI, E-5 | 565 |
| LS 6 | XLVI, D-3 | 493, 506 | LS 22 | LVIII, G-4 | 579 |
| LS 7 | XLVI, D-3 | 503, 506 | LS 23 | LVIII, G-6 | 588 |
| LS 8 | LI, D-4 | 556 | LS 24 | LVIII, G-6 | 588 and Addenda |
| LS 10 | LII (Kagemni) | 521 | LS 25 | LXII | 661 and Addenda |
| LS 12 | = S 2735 | 556 | LS 26 | LXII | 667 |
| LS 13 | LI, E-5 | 558 | LS 27 | LXI | 661 |
| LS 14 | XLVI, E-4 | 494 | LS 28 | LXI | 663 |
| LS 15 | = D 70 | 491 | LS 29 | LXI | 664 |
| LS 16 | XLVI, E-3 | 494 | LS 31 | LXI | 653 |
| LS 17 | LVIII, F-4 | 575 | LS 32 | unknown | 686 |
| LS 18 | LI, E-4 | 565 | | | |

(e) *Jéquier*

Map LXVII [2]

| No. | Page | No. | Page | |
|------------------|-------------------------------|---------|-------------------------------|-----|
| M. II | 680 | N. I | 676 | |
| M. III | 680 | N. II | 677 | |
| M. IV | 680 | N. III | 677 | |
| M. VI | 681 | N. IV | 677 | |
| M. VII | 681 | N. V | 678 | |
| M. VIII | position not marked on map | 688 | N. VI | 678 |
| M. IX | 682 | N. VII | 679 | |
| M. X (west part) | 682 | N. VIII | 679 | |
| M. XI | 682 | N. IX | 679 | |
| M. XII | 682 | N. X | 679 | |
| M. XIII | 683 | N. XI | 680 | |
| M. XIV | 684 | O. I | position not marked on map | |
| M. XV | 684 | O. II | position not marked on map | |
| M. XVI | 685 | | | |
| M. XVII | 685 | | | |

¹ Tomb LS 1, see *Bibl. iii*², Pt. 1, p. 351. LS 2-3, 9, 11, 21, and 30 have been omitted here.

(f) *Firth (C. M.) and Gunn (B.), Teti Pyramid Cemeteries (1926)*

Map LII

| No. | Page | No. | Page |
|-----|---------------------------------|----------|---------------------|
| 33 | 544 | HMK. 6 | 540 |
| 47 | 538 | HMK. 26 | 540 |
| 81 | 539 | HMK. 30 | 538 |
| 213 | 544 | HMK. 37 | 539 |
| 225 | 540 | HMK. 40 | 543 |
| 227 | 540 | HMK. 69 | 538 |
| 240 | shaft in mastaba of Kaemsenu | HMK. 120 | 538 |
| 255 | shaft in mastaba of Kaemsenu | HMK. 125 | 538 |
| | | HMK. 140 | 538 |
| | | HMK. 159 | position unknown |

| (g) <i>Quibell</i> | | | (i) <i>Various</i> | | |
|--------------------|------------------|--------------------|-------------------------|--------------------------------|--------|
| No. | Position on map | Page | Name | Position on map or equation | Page |
| 289 | LI, E-5 | 561 and Addenda | 'Tomb with Cow' | | 592 |
| 75 | LI, E-6 | 560 | 'Tombe du Defterdar' | LS 16 | 494 |
| 276 | LI, E-5/6 | 562 | 'Mastaba du Louvre' | | 634 |
| | (h) <i>Loret</i> | | 'Rue de Tombeaux' | | 511-16 |
| | Map LII | | Mastaba X | XLV, C-5 | 499 |
| No. | | Page | | | |
| 2 | | 552 | | | |
| 4 | | 553 | | | |
| 5 | | 553 | | | |

E. VIZIERS

The list includes Viziers quoted in *Top. Bibl.* iii², Part 1

Old Kingdom¹

| | Date | A. Weil, <i>Die Veziere des Pharaonenreiches</i> | Pages |
|-----------------|--|--|--------------------|
| Menka | Dyn. III(?) | — | 404 |
| Neferma'et | Snefru | AR 2 | 122 |
| Hemyunu | Khufu | — | 122 |
| Kawa'ab | Khufu | — | 118, 155, 187, 864 |
| Minkha'ef | Khufu to Khephren | — | 195 |
| Khufukha'ef [I] | Khufu to end of Dyn. IV | — | 188 |
| Nebemakhet | Khephren to Menkaurē' or a little later | — | 198, 199, 229, 230 |
| Nikaurē' | Khephren to end of Dyn. IV | AR 4 | 232 |

¹ For Imhōtep (later tradition), see p. 571. See also 'Ankh-ḥaf, p. 196; Babaf, p. 155; Neferma'et, p. 183; Duaenrē', p. 148.

| | <i>Date</i> | <i>A. Weil, Die Veziere des Pharaonenreiches</i> | <i>Pages</i> |
|--|---|--|--|
| Sekhemkarē ^c | Khephren to early Dyn. V | AR 5 | 233 |
| Kanūfer | advanced Dyn. IV or later | — | 893 |
| ‘Ankhma ^c rē ^c | end of Dyn. IV | — | 246 |
| Yunmin | end of Dyn. IV | AR 3 | 237 |
| Werbauba | Saḥurē ^c | — | 327 |
| Washptaḥ (Isi) | Neferirkarē ^c | AR 7 | 456 |
| name lost | early Dyn. V | — | 150 |
| Minnūfer | Neuserrē ^c | AR 9 | 337, 764 |
| Ptaḥshepses | middle Dyn. V | AR 8 | 337, 340, 571 |
| Peḥnuika | middle Dyn. V or later | AR 6 | 482, 491 |
| Ptaḥhotp | middle Dyn. V or later | AR 12 | 462 |
| Ptaḥhotp | middle Dyn. V or later | AR 10 | 653 |
| Ptaḥhotp-deshher | middle Dyn. V or later | AR 11 and 13 | 462 |
| Kai | middle Dyn. V or later | AR 19 | 479 |
| Thenti | middle Dyn. V or later | AR 33 | 482 |
| Seshemnūfer [III] | Isesi (early) | — | 82, 153, 153 |
| Ptaḥhotp [I] | Isesi | AR 14 | 596, 599, 608 |
| Ra ^c shepses | Isesi | — | 485, 489, 494, 497 |
| Senezemib (Inti) | Isesi | AR 16 | 85, 229 |
| Akhtihotp | Isesi–Unis | AR 15 | 597, 599, 605 |
| Ptaḥhotp [II] (Thefi) | Isesi–Unis | — | 599, 600, 606 |
| Senezemib (Meḥi) | Unis | AR 17 | 84, 85, 86, 87, 92, 129 |
| Sekhem‘ankhptaḥ | late Dyn. V or Dyn. VI | — | 191 |
| Akhtihotp (Ḥemi) | end of Dyn. V or early Dyn. VI | — | 627 |
| Tepem‘ankh [I] | end of Dyn. V. or Dyn. VI | AR 18 | 483 |
| Kagemni (Memi, Gemni) | Teti | AR 25 | 521, 546, 546 |
| Mereruka (Meri) | Teti | AR 26 | 525, 546, 569 |
| Khentka (Ikhekhi) | Pepy I | — | 508 |
| Ra ^c wēr | probably Pepy I (rather than late Dyn. VI) | — | 558 |
| Meryteti (Meri) | Pepy I or later | AR 27 | 536 (see name-index for other references) |
| Meḥu | Pepy I or later | — | 619 |
| ‘Ankhma ^c ḥor (Sesi) | early Dyn. VI | — | 512 |
| Neferseshemrē ^c (Sheshi) | early Dyn. VI | AR 24 | 511 |
| Nūfer (Idu [I]) | early Dyn. VI | — | 165 |
| Imameryrē ^c (Imapepy) | Pepy II | — | 683 |
| Ihykhent | Pepy II | — | 428 |
| Idi | Pepy II | — | 428, 678 |
| Niḥēbsed- neferkarē ^c | Pepy II | — | 683 |
| Kha ^c baukhnun (Biu) | Pepy II | — | 684 |
| Khenu | Pepy II | — | 427 |
| Shena ^c y | Pepy II | — | 678 |
| Teti | Pepy II | — | 684 |
| Mereri | late Dyn. VI | — | 607 |
| Thethu | probably late Dyn. VI | — | 537 |
| Sesi | end of Dyn. VI or 1st Int. Period | AR 28 | 689 |
| Iynefert | Dyn. VI | — | 616 |
| Ihy | Dyn. VI | — | 617, 619 |
| Ni ^c ankhba | Dyn. VI | — | 629 |
| Nebkauḥor (Idu) | Dyn. VI | — | 627 |
| Neferseshem- seshet (Khenu) | Dyn. VI | AR 23 | 585 |

Middle Kingdom

| | <i>Date</i> | M. Valloggia in <i>B.I.F.A.O.</i> 74 (1974), pp. 124-32 | <i>Pages</i> |
|-----------|------------------------|---|--------------|
| Ameny | Sesostris I | 7 | 832 |
| Sebkemḥet | probably Sesostris III | 11 | 897 |
| Khnemḥotp | probably Sesostris III | 12 | 896 |

New Kingdom¹

| | | W. Helck, <i>Zur Verwaltung des Mittleren und Neuen Reichs</i> , pp. 433-65 | |
|----------------------|-------------------------------------|---|---------------------------------|
| Neferweben | Tuthmosis III | 7 | 865 |
| Ptaḥmosi | Tuthmosis III | 8 | 773, 774 |
| Ptaḥmosi | Amenophis III | 14 | 721, 725 |
| Dḥutmosi | Amenophis III | 15 | 712 |
| ‘Aperir | probably Amenophis IV | — | 562 |
| ? | late Dyn. XVIII or Ramesside | — | 755 |
| Paser | Sethos I-Ramesses II | 24 | 771, 783, 783, 821, 838, 838 |
| Neferronpet | Ramesses II | 27 | 706 |
| Paraḥotp (Raḥotp) | Ramesses II | 28/29 | 665 |
| Ḥori | Merneptah-Siptah to Ramesses III | 39 | 731, 851, 861, 871 |
| To | Ramesses III | 40 | 861 |
| Neferronpet | Ramesses IV-VI | 41 | 707, 860 |
| Kha‘emwaset | Ramesses IX | 43 | 859 |

Late Period

| | | A. Weil, <i>Die Veziere des Pharaonenreiches</i> | |
|-----------------------------|----------------|--|-----|
| Bekenrenef | Psammetikhos I | SP 19 | 588 |
| Psammethek-sonb | Dyn. XXIX | SP 27 | 867 |
| Pedeneit (Pashe(n)tiḥet) | Dyn. XXX | — | 591 |

F. HIGH PRIESTS OF MEMPHIS

The title has been rendered ‘Greatest of the Directors of craftsmen’, with variants for the Old Kingdom (see Appendix G, titles 135-7). The list includes HPM quoted in *Top. Bibl.* iii², Part 1

Old Kingdom²

| | <i>Date</i> | D. W[ildung] in <i>Lexikon der Ägyptologie</i> (ed. W. Helck and W. Westendorf), ii. 1258-63 | <i>Pages</i> |
|------------------|------------------------|--|--------------|
| Ra‘nūfer | early Dyn. V | 5 | 461 |
| Ra‘neferref‘ankh | Ra‘neferref or later | 6 | 698 |
| Ptaḥshepses | Neuserreḥ | 3 | 327, 464 |
| Ptaḥshepses | probably middle Dyn. V | 9 | 464 |
| Sabu-kem | Dyn. V | 10 | 463 |
| Sethu | probably Dyn. V | 11 | 698 |
| Sabu (Ibebi) | Teti | 7 | 460 |

¹ The title of Ḥatiay, p. 43, is to be corrected to ‘Head of chisellers’.

² For No. 14 of *Lexikon der Ägyptologie*, see p. 730.

| Date | D. W[i]ldung] in <i>Lexikon der Ägyptologie</i> (ed. W. Helck and W. Westendorf), ii. 1258-63 | Pages |
|---|---|--|
| Ptaḥshepses [II] | Teti or later | 8 460 |
| Sabu (Thety) | Pepy II or later ¹ | 12 463 |
| Ptaḥshepses [I] | Dyn. VI | — 499 |
| Middle Kingdom and 2nd Int. Period | | |
| Sebkḥotp-ḥenku | Middle Kingdom | — 858 |
| Seḥetepebrē-ankh | Middle Kingdom | 17 571 |
| Senbuy | 2nd Int. Period | — 738 |
| New Kingdom and 3rd Int. Period | | |
| Ptaḥmosi | Tuthmosis III | 28 773, 774 |
| Ptaḥmosi | Amenophis III | 30 712, 727 |
| Dḥutmosi ² | Amenophis III | 31 780, 781, 851 |
| Ptaḥmosi | Amenophis III | 32/33 571, 712 |
| Ptaḥemḥēt (Ty) | Tutankhamūn or Ay | 38 571, 711 |
| Meryptaḥ | probably Ḥaremḥab | 37 706 |
| Kha'emwēset | Ramesses II | 50/57 704 (see name-index for other references) |
| Neferronpet | Ramesses II | 55 706 |
| Paḥemneter | probably Ramesses II | 34/47 571, 708, 727 |
| Iyiry | Sethos II | 59 704, 845, 865 |
| ? | Dyn. XIX | — 669 |
| Paḥemneter | probably Dyn. XIX | 46 871 |
| Ptaḥmosi | probably Dyn. XIX | — 759 |
| Ḥori | Merneptaḥ-Siptaḥ to Ramesses III | 58 851, 871 |
| Ḥori | late Dyn. XIX to early Dyn. XX | 58 703, 871 |
| Paḥemneter | late Dyn. XIX to Dyn. XX | 60 314, 731 |
| Kha'emwēset | Ramesses IX | 61 859 |
| Ḥori | probably Ramesside | 39 873 |
| Bekenamūn | New Kingdom | — 861 |
| Ptaḥmosi | New Kingdom | — 861 |
| Neterkheperrē- mer(y)ptaḥ (Paupau) | Siamūn | 64 853 |
| ʿAnkhefensekhmet | Sesonchis I | 68 760, 841, 866, 872 |
| Shedsunefertem | Sesonchis I | 69 760, 786, 823, 841, 842, 858, 866, 872 |
| ? | Sesonchis I | — 873 |
| Sheshonḳ | Osorkon II | 73 722, 785, 846, 875 |
| Merenptaḥ | Takelothis II | 72 785 |
| Thekerti | probably Sesonchis III | 74 786, 847, 873 |
| Pedēsi | Sesonchis III and later | 75 786, 786, 847 |
| Ḥarsiēsi | Pemu or later | 77 786, 847, 848 |
| ʿAnkhefensekhmet | Sesonchis V | 78 848 |
| Late Period | | |
| ʿAḥmosi-men (Irʿaḥeka) | Darius I | 80 801, 801, 803 |
| Khnebrē- siptaḥ (Nekau) | Darius I | 82 803 |
| ? | probably Late Period | — 592 |

¹ Rather than Pepy I, since the name appears in the Mortuary Temple of Pepy II (Jéquier, *Le Monument nétaire de Pepi II*, ii, pl. 74).

² The title not mentioned in *Top. Bibl.*

| | Date | D. W[ildung] in <i>Lexikon der Ägyptologie</i> (ed. W. Helck and W. Westendorf), ii. 1258-63 | Pages |
|-------------------------|------------------------------|--|--------------------|
| Ptolemaic Period | | | |
| Esisut (Pedubaste) | Ptolemy II Philadelphus | 85/86/87 | 743, 743, 747 |
| Zehø | Ptolemy III Euergetes I | 89 | 748 |
| Haremakheth | probably Ptolemy V Epiphanes | 90 | 718, 749 |
| 'Anemhø | probably Ptolemy V Epiphanes | 88 | 718, 747, 748 |
| Pedubaste | Cleopatra VII Philopator | 92 | 743 |
| Pashenptah | Cleopatra VII Philopator | 93 | 743, 744, 744, 744 |
| Pedubaste (Imhøtep) | Cleopatra VII Philopator | 95 | 744 |

G. OLD KINGDOM AND FIRST INTERMEDIATE PERIOD TITLES

The list includes several epithets, and also titles quoted in *Top. Bibl.* iii^a, Part 1

I. Occurrences

See Section II for hieroglyphic forms

1. Abdominal physician, 564.
2. Administrator of the Treasury, 295.
3. Adorer of Harzedef, 192.
4. Adorner of Horus, 451.
5. Assistant of Duau, 239, 258, 404, 426, 768.
6. Assistant leather-worker, 117.
7. Assistant royal scribe, 824.
8. *ꜥꜣw*-official, 100, 103.
Attendant of the Great House, *see* Keeper of
the legs of the Great House.
9. Barber, 350, 769.
10. Belonging to the foremost seat, 157, 190,
236.
11. Boat-builder, 728.
12. Book-keeper of the Great House, 298.
13. Book-keeper of the *mert*(?), 604.
14. Book-keeper of the royal documents, 306.
15. Boundary official, 117, 293, 632.
16. Boundary official of Dep, 125, 265, 281, 344.
17. Boundary official of a frontier-district,
143, 222, 721, 894.
18. Boundary official of a settlement, 68.
19. Boundary official of (the district) 'Star of
Horus Foremost of Heaven', 133, 723.
20. Boundary official (*rꜥ*) of the northern
settlement, 693.
21. Brewer, 48.
22. 'Brother of the endowment', 82, 640.
23. 'Brother of the endowment' of Ptaḥhotp
[II], 606.
24. Butcher of the Great House, 641.
25. Butcher of the slaughterhouse, 465, 502.
26. Butcher of the slaughterhouse of the Great
House, 253. *See also* Title 352.
27. Carpenter of the Great Dockyard, 143.
28. Carpenter of Nekhen, 633.
29. Carpenter of the Royal House, 110.
30. Chief of *bat*, 141, 223, 227, 263.
31. Chief of the estate, 538, 567, 569, 671, 673,
675, 677, 677, 679, 680, 681, 681, 681,
681, 682, 682, 682, 683, 683, 683, 684,
684, 685, 892.
32. Chief of the estate 'Mansion of Khufu', 50,
50.
33. Chief of the estate of Meres'ankh, 502.
34. Chief of an estate of the Pyramid of
Khephren, 292.
35. Chief of an estate of the Pyramid of Pepy I,
609, 609, 610.
36. Chief of an estate of the Pyramid of Pepy
II, 609.
37. Chief of a funerary estate of Snefru in the
Letopolite nome, 493.
38. Chief of the Great Estate, 405, 451, 493, 637.
39. Chief Justice and Vizier, *see* Appendix E.
40. Chief of the King, 260.
41. Chief lector-priest, 31, 74, 133, 187, 241,
427, 459, 487, 568, 736.
42. Chief lector-priest of his father, 234, 243.
43. Companion, 120, 155, 403, 403, 683.

44. Companion of the Great House, 193 (*as Inspector in error*), 207, 295.
45. Companion of his father, 200.
46. Companion of Horus, 624.
47. Companion of the house, 134, 164, 167, 167, 442, 520, 546, 569, 623, 625.
48. Count, 91, 191, 301, 393, 511, 518, 518, 566, 569, 609, 676, 676, 678, 684, 688, 694, 774.
49. [*cancelled*]
50. Count in Nekhen, 577.
51. Craftsman, 67, 67, 502, 823.
52. Dancer, 449.
53. Daughter of the God, 288 note 1.
54. Daughter of the God of his body, 179 note 1.
55. Dentist, 150.
56. Director of all divine offices, 306.
57. Director of bowmen, 57, 579, 824.
58. Director of brewers, 723.
59. Director of the Broad Hall, 222, 586, 632, 633.
60. Director of cattle-herdsmen, 61.
61. Director of corn-measurers, 69.
62. Director of a crew of recruits, 50, 58, 72, 96, 299, 544.
63. Director of the dining hall, 272, 272, 279, 547, 567, 683, 683, 698, 739.
64. Director of the dining hall of the Great House, 210, 544, 604.
65. Director of dwarfs in charge of dressing, 101.
66. Director of embalmers, 120.
67. Director of embalmers of the Great House, 122.
68. Director of the estates of the Red Crown, 563.
69. Director of eye physicians of the Great House, 258.
70. Director of hairdressers, 274.
71. Director of interpreters, 159.
72. Director of the *is*-chamber, 202.
73. Director of *kakau*-boats, 694.
74. Director of the kilt, 270, 480.
75. Director of King's hairdressers, 208, 258, 277.
76. Director of King's *warb*-priests, 53, 68, 105, 249, 693.
77. Director of King's *warb*-priests of the Pyramid of Khufu, 137.
78. [*cancelled*]
79. Director of members of a phyle, 49, 58, 220.
80. Director of members of a phyle of the Pyramid of Khephren, 302.
81. Director of the *mstt* and *mndt* barks, 672.
82. Director of *nšd-ms* metal-workers of the Great House, 698.
83. Director of the Palace, 5, 77, 78, 94, 135, 141, 200, 201, 208, 258, 263, 274, 343, 497, 723.
84. Director of the pastures, 7, 61.
85. Director of scribes, 454, 506.
86. Director of scribes of the granary, 157.
87. Director of scribes in the Great Broad Hall, 252.
88. Director of scribes of the house of the master of the largesse, 465, 741.
89. Director of scribes of the members of the Great Jury, 160.
90. Director of scribes of petitions, 451, 465, 485, 741, 759.
91. Director of singers, 639, 639.
92. Director of singers in the Two Houses, 640.
93. Director of smelters of gold, 505.
94. Director of tomb-makers, 116, 119, 211.
95. Director of the Two Canals, 308.
96. Director of the Two Seats, 227, 723.
97. Director of the Two Seats in the Mansion of Life, 223.
98. Director of vine-dressers, 205, 306, 745.
99. Director of *warb*-priests, 493.
100. Director of *warb*-priests of Sekhmet of the Great House, 638.
101. Director of the washing of hands of the Great House, 672.
102. Elder of the dockyard, 250, 250, 600, 608.
103. Elder(?) of the expedition, 214.
104. Elder of the Hall, 118, 118, 237, 293, 310, 723.
105. Elder of the Hall of the Pyramid of Khephren, 244.
106. Elder of the Hall of the Pyramid of Khufu, 211.
107. Elder of the Hall of the Pyramid of Menkaurē, 238.
108. Elder of the Hall of the Pyramid of Zadkarē, 608.
109. Elder of the house, 62, 107, 107, 140, 177, 178, 209, 271, 586, 732, 769.
110. Elder of the house of the Great Estate, 177.
111. Elder of the house of the hereditary prince, 104.
112. Elder of the *is*-chamber in the Two Houses, 598, 630.
113. Elder of the physicians of the Great House, 258, 563.
114. Eldest lector-priest, 563, 567, 568, 687.
115. Eldest son of his body of Khephren, the King of Upper and Lower Egypt, 243.
116. Embalmer, 107.
117. Embalmer of Anubis, 419, 427.
118. Eye physician, 210, 282, 564.
119. Eye physician of the Great House, 137, 288.
120. Favourite metal-worker of the Great House, 452.
121. Female steward, 103.
122. Flutist, 95.
123. Flutist of the Great House, 729.
124. Foremost of the Keepers of ornaments of dancers, 243.
125. Goldsmith, 55.
126. Gold-worker, 638.
127. Gold-worker of King's adorners, 568.
128. Great overlord of the Panopolite nome, 689.

129. Great overlord of the Thinite nome, 685, 691.
 130. Great *warb*-priest, 545, 563.
 131. Greatest of the *best*, 257, 258.
 132. Greatest of the craftsmen of the King, 211.
 133. Greatest of the dentists, 563.
 134. Greatest of the Directors of craftsmen, 499, 698, 698.
 135. Greatest of the Directors of craftsmen on the day of the festival, 461, 463.
 136. Greatest of the Directors of craftsmen in the Two Houses, 460, 464.
 137. Greatest of the Directors of craftsmen in the Two Houses on the day of the festival, 460, 463, 464.
 138. Greatest of the Five, 678, 684.
 139. [cancelled]
 140. Greatest of leather-craftsmen, 738.
 141. Greatest of physicians and dentists, 437.
 142. Greatest of the physicians of the Great House, 482.
 143. Greatest of the physicians of Lower Egypt, 451.
 144. Greatest of the physicians of Upper and Lower Egypt, 634.
 145. Greatest of the seers, 394, 403, 509.
 146. Greatest of the seers in On, 71.
 147. Greatest of the Ten of the Great Court, 253.
 148. Greatest of the Ten of the Mansion of Life, 253.
 149. Greatest of the Ten of Upper Egypt, 4, 48, 49, 59, 79, 84, 96, 124, 149, 158, 161, 190, 202, 241, 241, 248, 248, 252, 437, 693, 722.
 150. Hairdresser of the Great House, 62, 253.
 151. He who has command over Selkis, 137.
 152. [cancelled]
 153. *heka*-priest of Mehyt, 57.
 154. Herdsman of Apis, 183, 205, 216.
 155. Herdsman of *rekhyt*, 5, 228.
 156. Herdsman of Thentet-cattle, 261.
 157. Herdsman of the White Bull, 77, 159, 344.
 158. Hereditary prince, 155, 183, 187, 203, 203, 205, 228, 230, 239, 241, 274, 403, 427, 548, 645, 681, 683, 849.
 159. Honoured by Harzedef, 143.
 160. Honoured by Iny (Neuserrē), 345.
 160A. Honoured by Kagemni, 546.
 161. Honoured by the Lord of Panopolis, 687.
 162. Honoured by Merenrē I, 694.
 162A. Honoured by Meri, 569.
 163. *imy-hnt*, 307.
 164. Inspector, 246, 758.
 165. Inspector of administrators, 61.
 166. Inspector of administrators of the granary, 69.
 167. Inspector of administrators of the Treasury, 131, 191, 207, 207.
 168. [cancelled]
 169. Inspector of boat(s), 58, 299, 448, 768, 895.
 170. Inspector of book-keepers, 216.
 171. Inspector of builders, 54, 54, 80, 121, 178, 296.
 172. Inspector of carpenters of the Royal House, 114.
 173. Inspector of cooling of the Great House, 262.
 174. Inspector of corn-measurers of the estates, 115.
 175. Inspector of craftsmen, 108, 113, 116, 213, 281.
 176. Inspector of craftsmen of the *warbt*, 54, 287, 611.
 177. Inspector of dancers, 571.
 178. Inspector of embalmers, 87, 565.
 179. Inspector of an estate of Neferkarē, 738.
 180. Inspector of the Great House, 115, 145, 193 (*in error*, see title 44), 548, 570, 760.
 181. Inspector of hairdressers of the Great House, 447, 722.
 182. Inspector of *ka*-servants, 65, 83, 110, 112, 121, 139, 151, 161, 164, 177, 209, 228, 261, 261, 267, 271, 272, 275, 278, 544, 629, 678, 727, 727.
 183. Inspector of King's adorners of the Great House, 582.
 184. Inspector of King's hairdressers, 217, 306, 466, 540, 575, 586.
 185. [cancelled]
 186. Inspector of magazines(?), 447.
 187. Inspector of manicurists of the Great House, 213, 571 (*as hairdressers in error*).
 188. Inspector of masters of the largesse, 214.
 189. Inspector of metal-workers of the *warbt*, 63.
 190. Inspector of the most select of those who are in attendance (𓅓𓅓𓅓), 448, 734.
 191. Inspector of Nubians, 247.
 192. Inspector of officials (*strw*), 308, 310, 458, 548.
 193. Inspector of oils of King's adorners, 823, 827.
 194. Inspector of oils of King's adorners of the Great House, 451.
 195. Inspector of physicians, 288, 619, 736.
 196. Inspector of physicians of the Great House, 137, 209, 223, 288.
 197. Inspector of prophets, 116, 131, 144, 306, 545, 678, 686.
 198. Inspector of prophets of Hathor, 109, 214, 238. See also Title 201.
 199. Inspector of prophets of Hathor of the *meri*-temple, 633.
 200. Inspector of prophets of Hathor of the *meri*-temple of Unis, 483.
 201. Inspector of prophets of Hathor in the Sun-temple of Neferirkarē, 582.
 202. Inspector of prophets of her (i.e. of Wezebten's) funerary estate, 432.
 203. Inspector of prophets of Horus in the chapel (*snwt*), 608.
 204. Inspector of prophets of the *ka*-temple of Pepy I, 609.
 205. Inspector of prophets of the King's mother, 260.
 206. Inspector of prophets of Menkaurē, 261.
 207. Inspector of prophets of the *meri*-temple of Pepy I, 689.

208. Inspector of prophets of Ptah, 575.
 209. Inspector of prophets of the Pyramid of Isesi, 600. *See also title 219.*
 210. Inspector of prophets of the Pyramid of Khufu, 93.
 211. Inspector of prophets of the Pyramid of Menkauhor, 599, 600.
 212. Inspector of prophets of the Pyramid of Menkaurē, 250.
 213. Inspector of prophets of the Pyramid of Merenrē I, 691.
 214. Inspector of prophets of the Pyramid of Neuserrē, 599.
 215. Inspector of prophets of the Pyramid of Pepy I, 508, 536, 537, 621.
 216. Inspector of prophets of the Pyramid of Pepy II, 610, 685, 685.
 217. Inspector of prophets of the Pyramid of Teti, 508, 511, 512, 518, 525, 559, 563, 566, 607-8, 761.
 218. Inspector of prophets of the Pyramid of Unis, 615, 622, 627.
 219. Inspector of prophets of the Pyramid of Zadkarē, 599. *See also title 209.*
 220. Inspector of prophets of the Pyramid-town of Teti, 515.
 221. Inspector of prophets of Rē in the Sun-temple of Neferirkarē, 582.
 222. Inspector of the Pyramid of Pepy II, 742.
 223. Inspector of recruits, 215.
 224. Inspector of rowers of the bark, 294.
 225. Inspector of the Royal House, 544.
 226. Inspector of scribes, 111.
 227. Inspector of scribes of the crews, 275.
 228. Inspector of scribes of the granary, 8 (*as Overseer in error*), 106, 240, 696.
 229. Inspector of scribes of the house of the master of the largesse, 489, 690, 721.
 230. Inspector of scribes of petitions, 568, 582.
 231. Inspector of scribes of the royal documents, 165, 457, 480.
 232. Inspector of scribes of the royal documents of the granary, 123.
 233. Inspector of scribes of the royal documents of the Treasury, 218.
 234. Inspector of scribes of the royal light cloth (*ššp*), 218.
 235. Inspector of scribes of the royal linen (*ššrw*), 218.
 236. Inspector of scribes of sacrificial cattle, 622.
 237. Inspector of scribes of the sealed documents, 693, 724.
 238. Inspector of scribes of the Treasury, 276, 284, 309.
 239. Inspector of sculptors, 762.
 240. Inspector of *sem*-priests of Sokari, 829.
 241. Inspector of singers, 238, 641, 641.
 242. Inspector of singers of the Great House, 145.
 243. Inspector of singers to the flute, 465.
 244. Inspector of singers of the Pyramid of Userkaf, 581.
 245. Inspector of the store-room of the Sun-temple of Neuserrē, 307.
 246. Inspector of tenants, 53, 53, 92, 293, 306.
 247. Inspector of tenants of the Great House, 69, 76, 94, 108, 143, 143, 269, 281, 293, 546, 568, 607, 629, 630, 768, 891, 891, 892.
 248. Inspector of tenants of the Pyramid of Khephren, 292.
 249. Inspector of tenants of the Pyramid of Teti, 525.
 250. Inspector of treasurers of the Temple, 448, 449.
 251. Inspector of *warb*-priests, 50, 57, 62, 64, 93, 99, 178, 213, 213, 247, 248, 293, 306, 722.
 252. Inspector of *warb*-priests of the King's mother, 210, 213.
 253. Inspector of *warb*-priests of Menkaurē, 261.
 254. Inspector of *warb*-priests of the Pyramid of Khephren, 184, 185, 193, 207, 207, 307, 308.
 255. Inspector of *warb*-priests of the Pyramid of Khufu, 49, 66, 105, 110, 117, 138, 166, 185, 344.
 256. Inspector of *warb*-priests of the Pyramid of Neuserrē, 600.
 257. Inspector of *warb*-priests of the Pyramid of Sahurē, 344.
 258. Inspector of *warb*-priests of the Pyramid of Snefru, 96.
 259. Inspector of *warb*-priests in (*or of*) the Pyramid of Userkaf, 491, 577, 580.
 260. Inspector of *warb*-priests of Rē in the Sun-temple of Userkaf, 577.
 261. Inspector of *warb*-priests in the Sun-temple of Userkaf, 578.
 262. Inspector of the *warbt*, 54, 639.
 263. Inspector of workmen of the *warbt* of the Necropolis, 113.
 264. Inspector of young men of the Great Estate, 279.
 265. Inspector of young men of the Great House, 299.
 266. Inspector of *rh-ntry*, 302, 302.
 267. Inspector . . . of the Pyramid of Pepy II, 679.
 268. *iun-kenmut*-priest, 159, 221, 238, 242, 249, 448.
 269. *iry-ntr*, 317, 317, 317.
 270. Judge and Book-keeper, 68, 598.
 271. Judge and Boundary official, 5, 127, 142, 157, 160, 162, 178, 221, 238, 242, 249, 250, 280, 448, 458, 501, 565, 579, 601, 757, 759, 760, 762, 768.
 272. Judge and Boundary official of the Great House, 60.
 273. Judge and Elder of the dockyard, 692.
 274. Judge and Elder of the Hall, 87, 94, 126, 135, 214, 246, 253, 457, 458, 593.
 275. Judge and Inspector of book-keepers, 251, 464, 480, 565, 582, 585, 697.
 276. Judge and Inspector of scribes, 115, 251, 298, 487, 496, 604, 690, 690, 892.
 277. Judge and Inspector of tenants of the Great House, 113.
 278. Judge and Keeper of Nekhen, 87, 310, 543, 627, 823.

279. Judge and Keeper of Nekhen who judges rightly, 246.
280. Judge and Master of the largesse, 405, 451, 692, 769.
281. Judge and Overseer of scribes, 84, 111, 138, 158, 160, 163, 167, 179, 222, 222, 238, 293, 456, 480, 481, 482 (of the book), 490, 583, 606, 606, 637, 699, 736, 898.
282. Judge and Overseer of scribes of the herds, 544 (*perhaps thus*).
283. Judge and Overseer of scribes of the secret judgement of the Great Court, 160.
284. Judge and Real keeper of Nekhen, 769.
285. Judge and Royal scribe, 54.
286. Judge and Scribe, 97, 202, 493, 568, 593, 692, 723.
287. Judge and Scribe of the crews, 135.
288. Judge and Scribe of petitions, 570.
289. Judge in the Six Great Courts, 673.
290. Judge and Strong-of-voice, 52.
291. Judge and Strong-of-voice of the granary, 62.
292. Judge and Supervisor of police, 308, 722.
293. *ka*-servant, *passim*.
294. *ka*-servant of the endowment of Sole companion Ra'wēr, 271.
295. *ka*-servant of the endowment of Werirni, 478.
296. *ka*-servant of the King's mother, 284.
297. *ka*-servant of (Senezemib) Mehi, 92.
298. *ka*-servant of Ptahhotp [I], 608.
299. Keeper of the diadem, 208, 217, 253, 274, 277, 306.
300. Keeper of the diadem in the place of the King (?), 243.
301. Keeper of the dining-room (?) of the royal repast of the Great House, 739.
302. Keeper of the dockyard, 220.
303. Keeper of the gate, 761.
304. Keeper of the legs (*better*: Attendant) of the Great House, 192.
305. Keeper of the linen (*ššrw*) of the Royal House, 306.
306. Keeper of the magazine, 610.
307. Keeper of the magazine of gold, 178.
308. Keeper of Nekhen, 191.
309. Keeper of oils of the Great House, 133.
310. Keeper of the whole Pe, 216.
311. Keeper of the writing material of the King, 739.
312. *khet*-priest of Ha, 339.
313. *khet*-priest of Thentet-cattle, 134.
314. *khet*-priest of Wēr, 134.
315. *khet*-priestess of Horus, 179 note 1.
316. King's adorning, 72, 96, 99, 274, 286, 299, 485, 671, 678, 678, 690, 727, 769, 893.
317. King's adorning and Keeper of gold, 247.
318. King's adorning and Keeper of unguents, 99.
319. King's architect and builder, 542, 542, 543.
320. King's architect and builder in the Two Houses, 85, 87, 89-90.
321. King's daughter, 59, 72, 139, 139, 153, 277, 281, 340, 343, 403, 407, 431 note 1, 432 note 1, 482, 496, 545, 895.
322. King's daughter of his body, 3, 3, 52, 71, 87, 124, 134, 136, 139, 191, 194, 197, 200, 216, 230, 233, 249, 256, 396 note 1, 515, 518, 521, 606, 617, 619, 723, 878.
323. King's eldest daughter, 464.
324. King's eldest daughter of his body, 243, 273, 508, 525, 614.
325. King's eldest son, 3, 230, 679, 683, 684, 684.
326. King's eldest son of his body, 3, 3, 26, 187, 214, 232, 233, 237, 246, 274, 293, 487, 536, 627, 675, 893.
327. King's hairdresser, 265.
328. King's mother, 273, 396 note 1, 577, 676.
329. King's [secretary] of all secret commands of the frontier-posts, 519.
330. King's sole adorning, 271, 282, 301, 492, 496, 511, 539, 544, 545, 563, 564, 568, 568, 568, 610, 610, 674, 674, 674, 676, 676, 677, 681, 681, 686, 686, 687, 688, 688, 741.
331. King's son, 10, 57, 59, 124, 183, 194, 201, 202, 219, 234, 239, 241, 241, 403, 403, 489, 489, 616, 630, 645, 879, 892, 894.
332. King's son of his body, 5, 31, 71, 74, 78, 99, 122, 125, 149, 153, 188, 191, 195, 200, 203, 203, 204, 211, 230, 234, 277, 548, 577, 585, 864, 878, 890, 893.
333. King's *warb*-priest, *passim*.
334. King's *warb*-priest of the Great House, 70, 259, 449.
335. King's *warb*-priest of the *mert* of Userkaf, 581.
336. King's *warb*-priest of the Palace (*ḏbt*), 238.
337. King's *warb*-priest of the Pyramid of Khufu, 50, 211.
338. King's wife, 194, 233, 249, 256, 273, 396 note 1, 397 note 1, 431 note 1, 432 note 1, 432 note 2, 479, 482, 488, 624, 676.
339. Leader of the land of the Aphroditopolite nome, 143.
340. Leader of the land of the Oryx-nome, 405.
341. Leader of the land of the Thinite nome, 143.
342. Leather-worker, 311.
343. Lector-priest, *passim*.
344. Lector-priest of the *ḏbt*-bark of Horus, 519, 630.
345. Lector-priest of the endowment, 736.
346. Lector-priest of his father, 31.
347. Lector-priest of the *mit*-bark of Horus, 519, 630.
348. Lector-priest of Neferirkarē, 161.
349. Lector-priest of Saḥurē, 161.
350. Magician of Selkis of the Great House, 272.
351. Manicurist, 271, 350.
352. Master butcher of the Great House, 614, 639, 644. *See also Title 26*.
353. Master of the Great House, 238.
354. Master of the house of the Great House, 137, 165, 178.

355. Master of the house of tenants of the Great House, 287.
356. Master of the largesse in the Mansion of Life, 135, 235, 254, 281, 307, 478.
357. Master of the largesse in the Mansion of Life of Seshet, 452.
358. Master of the largesse of *rekhyt*, 214, 215.
359. Master of the Palace (*ḏbt*), 68.
360. Master of the royal largesse, 219.
361. Master of wood, 279.
362. Metal-worker of the Great House, 506, 608.
363. Metal-worker in the Two Houses, 452.
364. *mḥnk* of the King, 461, 499, 611, 768.
365. Mistress of the house, 54.
366. *mītrt*, 12, 50, 62, 63, 64, 72, 82, 97, 97, 99, 99, 100, 100, 103, 103, 104, 114, 117, 119, 120, 121, 129, 176, 178, 203, 207, 212, 217, 218, 220, 286, 302, 307, 490, 502, 506, 586, 652, 692, 735, 738, 740, 895.
367. Mother of the King of Upper and Lower Egypt, 179 note 1.
368. Mother of the two Kings of Upper and Lower Egypt, 288 note 1.
369. Mourner (*ḏrt*), 349.
370. Noble of the King, 60, 167, 167, 168, 192, 520, 546, 546, 547, 547, 548, 548, 569, 608, 622, 623, 625, 646, 652, 747, 770.
371. Noble of the King of the Great House, 625.
372. Noblewoman of the King, 539, 681, 683, 688, 688, 723, 774, 898.
373. Official (*sr*) of the Acacia-house, 507.
374. Official (*iry-ḥt*) of the Chamber of unguents of King's adorners, 458.
375. One belonging to the endowment of Ni'ankh-khnum and Khnemhotp, 644.
376. One belonging to the estate 'Mansion of Har-kheper (Ra'zedef)', 142.
377. One belonging to the Great Estate, 121, 121.
378. One who is in the magistracy, 748.
379. One who sets right the judgement, 686.
380. One who sets right the judgement of the Great Court, 248, 306, 308.
381. Overlord of linen (*ḏt*), 678.
382. Overlord of linen (*ššrw*), 106.
383. Overlord of Nekheb, 183, 235, 272, 585, 694, 723.
384. Overseer of all craftsmen, 465.
385. Overseer of all his (Ra'wēr's) properties in and outside the endowment, 269.
386. Overseer of all trees of Memphis, 761.
387. Overseer of all works, 243.
388. Overseer of all works of the King, 48, 89, 137, 146, 149, 155, 161, 163, 212, 234, 242, 344, 452, 481, 485, 489, 500, 502, 586.
389. Overseer (*mdh*) of Anubis foremost of the Sacred Land, 449.
390. Overseer of barbers, 84, 116.
391. Overseer of beef fat, 641, 644.
392. Overseer of bleachers of linen, 735.
393. Overseer of boat-nets, 98.
394. Overseer of the Broad Hall, 241.
395. Overseer of builders, 54, 203.
396. Overseer of butchers of the slaughterhouses of the Great House, 690.
397. Overseer of butlers, 255.
398. Overseer of carpenters, 63.
399. Overseer of carpenters of the *is*-chamber of the Royal House, 72.
400. Overseer of cattle of the Ibis-nome, 7.
401. Overseer of cattle-stalls, 276.
402. Overseer of the chamber of dancers, 895.
403. Overseer of commands (of the King), 262.
404. Overseer of commissions, 57, 77, 94, 159, 165, 308, 563, 596, 898.
405. Overseer of commissions in the whole country, 159.
406. Overseer of commissions of cedar, 158.
407. Overseer of commissions of the Great House, 75, 162, 247.
408. Overseer of commissions of the Pyramid of Iseti, 424.
409. Overseer of commissions of the Pyramid of Neuserre', 315.
410. Overseer of commissions of the Pyramid of Pepy I, 753.
411. Overseer of commissions of the Pyramid of Unis, 748.
412. Overseer of commissions of the Sun-temple of Neuserre', 315.
413. Overseer of commissions of tenants of the Great House, 109, 153.
414. Overseer of commissions of tenants of the Pyramid of Iseti, 424.
415. Overseer of commissions of tenants of the Pyramid of Pepy I, 546, 630.
416. Overseer of commissions of tenants of the Pyramid of Teti, 520.
417. Overseer of corn-measurers, 62, 120.
418. Overseer of craftsmen, 108, 117, 140, 192, 689, 762, 768.
419. Overseer of craftsmen of the Great House, 138.
420. Overseer of craftsmen of the *wacbt*, 273, 453.
421. Overseer of the crew of rowers, 114.
422. Overseer of dancers of the King, 282.
423. Overseer of dates, 309.
424. Overseer of dentists, 295 (as physicians).
425. Overseer of the department, 116, 176, 260.
426. Overseer of the department of the Great House, 104, 287, 652, 680, 686.
427. Overseer of the department of tenants, 545.
428. Overseer of the department of tenants of the Great House, 53, 56, 80, 109, 126, 134, 148, 152, 160, 164, 269, 284, 286, 518, 547, 570, 614, 646, 698, 892.
429. Overseer of the desert(s), 238, 729.
430. Overseer of directors, 741.
431. Overseer of the dockyard, 99.
432. Overseer of draughts-players of the crews, 100.
433. Overseer of the duck-pond, 450, 478.
434. Overseer of entertainment, 145.
435. Overseer of the expedition, 58, 137, 148, 204, 238, 240, 246, 262, 482, 489, 489, 492, 544, 544, 562, 564, 565, 569, 570, 611, 681, 685, 890.

436. Overseer of faience-workers, 652.
 437. Overseer of Farâfra Oasis, 721.
 438. Overseer of female dancers, 61.
 439. Overseer of female singers, 450.
 440. Overseer of female weavers, 120.
 441. Overseer of the fields, 450.
 442. Overseer of the five of the boat, 214.
 443. Overseer of the five . . . of the Great House, 898.
 444. Overseer of flutists, 129.
 445. Overseer of the four of the boat, 214.
 446. Overseer of fringed cloth (*sî't*) of the King, 488.
 447. Overseer of the gangs, 272.
 448. Overseer of the gates in the Two Houses, 222.
 449. Overseer of gold of the magazines in the Two Houses, 586.
 450. Overseer of gold-workers, 645.
 451. Overseer of gold-workers of King's adorners, 456.
 452. Overseer of the granary, 262, 491, 610, 691, 696.
 453. Overseer of the Great Court, 159, 586, 633.
 454. Overseer of the Great Estate, 51, 109, 698.
 455. Overseer of the *g's-pr*, 301, 622, 675, 681, 682, 682, 682, 684.
 456. Overseer of the *g's-pr* of the Necropolis, 212.
 457. Overseer of the *g's-pr* of tomb-makers, 50.
 458. Overseer of 'Hair of the Earth', 517, 569.
 459. Overseer of hairdressers of the Great House, 453, 637, 698.
 460. Overseer of herds, 211.
 461. Overseer of the House of Cedar, 165.
 462. Overseer of the House of Weapons, 72, 87.
 463. Overseer of the House of weaving women, 65, 109.
 464. Overseer of the House of weaving women of the Residence, 269 (*translated differently*), 465.
 465. Overseer of the House of *wehar*-boats, 264.
 466. Overseer of the houses of the King's children, 50, 135.
 467. Overseer of hunters, 292.
 468. Overseer of interpreters, 311, 892.
 469. Overseer of the *is*-chamber, 118.
 470. Overseer of the *is*-chamber of hairdressing, 727.
 471. Overseer of the *is*-chamber of the *warbt*, 116.
 472. Overseer of judgement, 506.
 473. Overseer of the jury, 723.
 474. Overseer of the jury of the Pyramid of Menkaurê, 294.
 475. Overseer of *ka*-servants, 62, 75, 82, 105, 106, 108, 121, 135, 137, 202, 204, 210, 213, 244, 245, 251, 271, 271, 280, 285, 285, 286, 470, 506, 690.
 476. Overseer of *ka*-servants of the endowment of Kanenesut, 144.
 477. Overseer of *ka*-servants of the endowment (of Rekhtrê), 250.
 478. Overseer of *ka*-servants of the King's mother, 210, 284, 284.
 479. Overseer of *ka*-servants of the King's wife (probably Rekhtrê), 262.
 480. Overseer of *ka*-servants of the Pyramid of Ra'zedef, 7.
 481. Overseer of *ka*-servants of Send in the Necropolis, 490.
 482. Overseer of the King in all his departments, 96.
 483. Overseer of King's adorners, 586.
 484. Overseer of King's adorners of the Great House, 691.
 485. Overseer of King's *harîm*, 152 (*translated differently*), 453.
 486. Overseer of the King's house, 545.
 487. Overseer of the King's *warbt*, 64, 736.
 488. Overseer of ladies of the *harîm*, 450.
 489. Overseer of the ladies of the *harîm* of the King, 282.
 490. Overseer of leather-workers, 570, 758.
 491. Overseer of the Letopolite nome, 166, 179, 201.
 492. Overseer of linen (*ššrw*), 127, 275, 278, 488, 511, 548, 678, 678, 682, 687, 722, 736.
 493. Overseer of linen (*ššrw*) of the endowment, 265.
 494. Overseer of linen (*ššrw*) of the Pyramid of Khephren, 295.
 495. Overseer of linen (*ššrw*) of the Pyramid of Khufu, 295.
 496. Overseer of manicurists of the Great House, 242, 453, 455, 641.
 497. Overseer of the marsh-lands, 478.
 498. Overseer of the Memphite nome, 166, 179, 201.
 499. Overseer of metal-workers, 645, 767.
 500. Overseer of metal-workers of the Great House, 609, 611.
 501. Overseer of miners, 736.
 502. Overseer of the *nehet*-sanctuary of the *mert* of Ḥathor, 578.
 503. Overseer of the new settlements, 55.
 504. Overseer of the new settlements of the Pyramid of Isesi, 166, 201.
 505. Overseer of the nomes of Lower Egypt, 609.
 506. Overseer of the Nubian troops, 439.
 507. Overseer of officials (*šrw*), 246, 262, 307, 613, 722.
 508. Overseer of oils of the King's adorners, 577.
 509. Overseer of oils in the Two Houses, 826.
 510. Overseer of the Palace (*rh*), 242, 598, 741.
 511. Overseer of the Palace (*db:t*), 768.
 512. Overseer of Per-nu of the Great House, 262.
 513. Overseer of the phylai of Upper Egypt, 59, 124, 158, 894, 895.
 514. Overseer of physicians, 284. *See also title* 424.
 515. Overseer of prophets of Ḥathor Mistress of Nidua-snefru, 678.
 516. Overseer of prophets of Onuris, 691.
 517. Overseer of prophets of the Pyramid of Userkaf, 769.
 518. Overseer of the Pyramid of Khephren, 241, 248, 248, 249, 302.
 519. Overseer of the Pyramid of Khufu, 58.

520. Overseer of the Pyramid of Menkaurē, 298.
 521. Overseer of the Pyramid of Neferirkarē, 468.
 522. Overseer of the Pyramid of Neuserrē, 468.
 523. Overseer of the 'Pyramid' of Shepseskaf, 213.
 524. Overseer of the Pyramid of Snefru, 893.
 525. Overseer of the Pyramid-town of Kakai (Neferirkarē), 344.
 526. Overseer of the Pyramid-town of Khephren, 257.
 527. Overseer of the Pyramid-town of Khufu, 48, 64, 66, 68, 184, 306.
 528. Overseer of the Pyramid-town of Menkauhor, 599.
 529. Overseer of the Pyramid-town of Menkaurē, 184.
 530. Overseer of the Pyramid-town of Neuserrē, 599.
 531. Overseer of the Pyramid-town of Teti, 521.
 532. Overseer of the Pyramid-town of Zadkarē (Isesi), 599.
 533. Overseer of the Residence (*lnw*), 277.
 534. Overseer of the Road of Horus, 238.
 535. Overseer of the royal commissions of the Pyramid of Pepy I, 90.
 536. Overseer of royal fortresses, 729.
 537. Overseer of the royal granary/ies, 137, 449.
 538. Overseer (*mdh*) of the royal scribes, 84, 437.
 539. Overseer of the royal sealed documents of the Great House, 213.
 540. Overseer of the royal sealed documents of the land, 213.
 541. Overseer of the royal sealed documents of the *meret*, 213.
 542. Overseer of the sail(?), 548.
 543. Overseer of scribes, 157, 160, 163, 251, 307, 565, 596, 652.
 544. Overseer of scribes of the crews, 72, 96, 211, 211, 457, 592, 611, 735.
 545. [cancelled]
 546. Overseer of scribes of the Great Court, 606.
 547. Overseer of scribes of the land, 236, 241, 451, 760.
 548. Overseer of scribes of the land of the Sebennite nome, 768.
 549. Overseer of scribes of the land of  nome, 443.
 550. Overseer of scribes of the land in the Two Houses, 450, 465, 608.
 551. Overseer of the scribes of the land in the Two Houses of Upper and Lower Egypt, 451.
 552. Overseer of scribes of the *meret*, 185.
 553. Overseer of scribes of the Pyramid of Khufu, 64, 284.
 554. Overseer of scribes of the royal documents, 146, 163, 456, 501, 686.
 555. Overseer of scribes of the royal documents of all works of the King, 484.
 556. Overseer of scribes of the royal sealed documents, 241.
 557. Overseer of scribes of the sealed documents, 566.
 558. Overseer of scribes of the Two Granaries, 823.
 559. Overseer of sculptors, 52, 451, 601, 690.
 560. Overseer (*mdh*) of sculptors, 403, 404, 437, 437.
 561. Overseer (*mdh*) of sculptors in the Two Houses, 499.
 562. Overseer of the seal(?), 517.
 563. Overseer of singers of the Great House, 129, 468, 468.
 564. Overseer of singing in the Great House, 174, 282.
 565. Overseer of the six of the boat, 448, 768.
 566. Overseer of smelters of gold, 546.
 567. Overseer of smelters of gold of King's adorners, 754.
 568. Overseer of the southern Pyramid of Snefru, 894.
 569. Overseer of the store-room, 68 (*translated differently*), 120, 140, 177, 308, 351, 433, 544, 548, 735, 736, 769.
 570. Overseer of the store-room of the King's repast, 214, 280, 295, 447.
 571. Overseer of the store-room of the Sun-temple of Userkaf, 303.
 572. Overseer of strongholds of the Heliopolitan-East nome, 143.
 573. Overseer of the Sun-temple of Neferirkarē, 468.
 574. Overseer of the Sun-temple of Neuserrē, 468.
 575. Overseer of the Sun-temple of Ra'neferef, 468.
 576. Overseer of the Sun-temple of Sahurē, 468.
 577. Overseer of the *tyw* of the Great Bark, 116.
 578. Overseer of the ten, 54, 148, 177, 736.
 579. Overseer of the ten of the boat, 96, 104, 214, 448.
 580. Overseer of the ten craftsmen, 611.
 581. Overseer of the ten craftsmen of the *warbt*, 54.
 582. Overseer of the ten of the Great Bark, 736.
 583. Overseer of the ten of the Great Estate, 112.
 584. Overseer of the ten of the Great House, 152.
 585. Overseer of tenants, 622, 742.
 586. Overseer of tenants of the Great House, 60, 94, 120, 261, 545, 604, 622, 673, 675, 679, 679, 680, 687, 687, 694, 699, 774.
 587. Overseer of tenants of the Pyramid of Pepy I, 678.
 588. Overseer of tenants of the Pyramid of Teti, 567.
 589. Overseer of tomb-makers, 116.
 590. Overseer of the Treasury, 54, 64, 96, 98, 259, 466, 478, 494, 501, 736, 739.
 591. Overseer of the Treasury of Khufu, 760.
 592. Overseer of the Treasury of Ra'zedef, 760.
 593. Overseer of the Treasury of the Residence, 455.
 594. Overseer of the Treasury of Snefru, 760.
 595. Overseer of the treasury of the two boat-crews, 276.

596. Overseer of Tura quarries, 586.
 597. Overseer of tutors of the King's children of his body, 240.
 598. Overseer of the Two Canals of the Great House, 698.
 599. Overseer of the Two Cool Chambers of the Great House, 678, 680, 680, 681.
 600. Overseer of the Two Granaries, 454, 506, 511, 537, 565, 651.
 601. Overseer of the Two Houses of Gold, 257, 258, 452.
 602. Overseer of the Two Houses of Weapons, 126.
 603. Overseer of the two *is*-chambers of the King's adorners of the Great House, 577.
 604. Overseer of the two Pyramids of Snefru, 894.
 605. Overseer of the Two Treasuries, 137, 205, 212, 257, 258, 506, 604, 684.
 606. Overseer of Upper Egypt, 428, 494, 519, 537, 616, 675, 678.
 607. [cancelled]
 608. Overseer of *warb*-priests of Peribsen in the Necropolis, 490.
 609. Overseer of the *warbt*, 54, 138, 611.
 610. [cancelled]
 611. Overseer of washermen, 97, 116.
 612. Overseer of weavers of the Great House, 100.
 613. Overseer of works, 91, 205, 451.
 614. Overseer of works of the King, 138, 202, 693, 697.
 615. Overseer of young men, 465.
 616. Overseer of the young men in the endowment of Companion Ra'wēr, 269.
 617. Painter, 231, 282.
 618. Physician, 282, 601.
 619. Physician of the Great House, 228, 258, 540.
 620. Policeman, 60.
 621. Prophet, 153, 276, 724, 829.
 622. Prophet of Anubis, 253.
 623. Prophet of Anubis foremost-of-Sepa, 223.
 624. Prophet of Bubastis, 453.
 625. Prophet of Buto, 274, 638.
 626. Prophet of Buto in Pe and Dep, 265.
 627. Prophet of Duamutf, 122.
 628. Prophet of Duau, 288.
 629. Prophet of Ḥathor, 149, 212, 464.
 630. Prophet of Ḥathor foremost of the Pyramid of Userkaf, 578.
 631. Prophet of Ḥathor Mistress of Dendera, 633.
 632. Prophet of Ḥathor in the Sun-temple of Neferirkarē, 174, 453, 498, 577, 584, 596, 693, 697, 699, 723.
 633. Prophet of Ḥathor in the Sun-temple of Userkaf, 723.
 634. Prophet of Heka, 223, 451, 634.
 635. Prophet of Heḳet, 57, 142, 339, 502, 633, 762.
 636. Prophet of Horus *kmw-r*, 127, 443, 450.
 637. Prophet of Horus *mḏdw* (Khufu), 76, 137, 140, 140, 153, 168, 178.
 638. Prophet of Horus of Mesen, 579.
 639. Prophet of Horus and Sēth foremost of the divine monument, 736.
 640. Prophet of Horus of Shenwet(?), 223, 451.
 641. Prophet of Horus *wšr-ib* (Khephren), 244.
 642. Prophet of *hrwy-nb* (Golden Horus name of Khufu), 140, 178.
 643. Prophet of Khephren, 7, 98, 213, 241, 241, 244, 247, 248, 253, 258, 272, 308, 467.
 644. Prophet of Khnem-khufu, 97, 271.
 645. Prophet of Khnum, 453.
 646. Prophet of Khnum in all his places, 634.
 647. Prophet of Khnum foremost of Ḥer-wēr in all his places, 482.
 648. Prophet of Khufu, 53, 56, 58, 58, 64, 64, 70, 76, 79, 98, 101, 105, 109, 110, 116, 117, 118, 126, 137, 140, 140, 141, 152, 153, 155, 168, 169, 170, 178, 200, 210, 220, 273, 278, 482, 483, 693, 756, 824.
 649. Prophet of Khufu foremost-of-the-*akhet*-Pyramid, 50.
 650. Prophet of the King's mother, 111, 257.
 651. Prophet of Ma'et, 79, 94, 162, 221, 236, 252, 280, 293, 632, 722.
 652. Prophet of *mḏd-r-nbty* (*nebty*-name of Khufu), 76, 137, 140, 152, 177.
 653. Prophet of Menkaurē, 82, 213, 253, 254, 261, 272, 279, 287, 294, 298, 306, 483.
 654. Prophet of Mert of Upper Egypt, 639.
 655. Prophet of the *mert*-temple of Menkauhor, 611.
 656. Prophet of Min Lord of Panopolis, 567.
 657. Prophet of *nbty-wšr-m* (*nebty*-name of Khephren), 244.
 658. Prophet of Nebka, 500.
 659. Prophet of Neferirkarē, 169, 174, 453, 463, 596, 760.
 660. Prophet of Neith, 405.
 661. Prophet of Nekhbet, 274, 577.
 662. Prophet of Neuserre, 106, 106, 169, 174, 245, 453, 596.
 663. Prophet of Osiris, 254.
 664. Prophet of Ptaḥ, 273, 453, 499, 689, 753, 762, 768.
 665. Prophet of the Pyramid of Isesi, 260, 455, 633. *See also title 676.*
 666. Prophet of the Pyramid of Khephren, 292.
 667. Prophet of the Pyramid of Menkauhor, 55, 191, 585, 595.
 668. Prophet of the Pyramid of Merenrē I, 609.
 669. Prophet of the Pyramid of Neferirkarē, 447, 584.
 670. Prophet of the Pyramid of Neuserre, 55, 463, 481, 485, 584, 595, 722.
 671. Prophet of the Pyramid of Pepy I, 519.
 672. Prophet of the Pyramid of Ra'neferef, 584.
 673. Prophet of the Pyramid of Saḥurē, 52.
 674. Prophet of the Pyramid of Teti, 520, 559, 608.
 675. Prophet of the Pyramid of Unis, 460, 608, 622, 626, 627, 633.
 676. Prophet of the Pyramid of Zadkarē (Isesi), 595, 693, 697. *See also title 665.*
 677. Prophet of Ra'neferef, 453, 581.

678. Prophet of Raʿzedef, 3, 98, 101.
679. Prophet of Rēc, 464, 691.
680. Prophet of Rēc in the Sun-temple of Menkauhor, 191, 245, 460.
681. Prophet of Rēc in the Sun-temple of Neferirkarēc, 174, 254, 453, 460, 463, 464, 467, 481, 492, 494, 498, 541, 541, 577, 583, 584, 595, 596, 608, 693, 697, 699, 723.
682. Prophet of Rēc in the Sun-temple of Neuserre, 53, 56, 106, 245, 282, 460, 464, 467, 498, 593, 595, 641, 643, 696.
683. Prophet of Rēc in the Sun-temple of Sahurē, 722.
684. Prophet of Rēc in the Sun-temple of Userkaf, 52, 449, 460, 463, 464, 467, 481, 498, 541, 568, 581, 583, 723, 744, 768, 769, 894.
685. Prophet of Sahurēc, 52, 106, 169, 174, 214, 240, 447, 453, 467, 481, 583, 606, 744.
686. Prophet of Sed, 596.
687. Prophet of Seshet, 84, 449.
688. Prophet of the shrine of Anubis in Aphroditopolis, 106.
689. Prophet of the shrine of Sēth, 736.
690. Prophet of Snefru, 878, 890, 893, 895, 895, 895.
691. Prophet of Snefru foremost of the ḥr-pyramid, 879.
692. Prophet of Sokari, 273, 453, 499, 689, 762.
693. Prophet of Sopt, 403, 502.
694. Prophet of the Souls of Nekhen, 253.
695. Prophet of the statue (of Khephren), 143.
696. Prophet of the Sun-temple of Neferirkarēc, 478, 689.
697. [cancelled]
698. Prophet of the Sun-temple of Userkaf, 478, 483, 582, 762.
699. Prophet of Termuthis, 501.
700. Prophet of Thoth, 502.
701. Prophet of Userkaf, 498, 581, 581.
702. Prophet of Wepwaut, 253.
703. Prophetess of Hathor, 51, 55, 55, 66, 72, 77, 80, 87, 99, 101, 104, 118, 134, 135 (interpreted incorrectly), 143, 149, 150, 162, 167, 179, 184, 200, 205, 212, 229, 240, 243, 245, 254, 261, 273, 274, 274, 282, 286, 298, 303, 304, 306, 310, 450, 451, 458, 460, 482, 483, 501, 511, 518, 539, 539, 541, 544, 544, 545, 546, 546, 548, 548, 548, 563, 564, 565, 566, 567, 568, 568, 568, 568, 568, 570, 577, 578, 596, 608, 610, 610, 623, 641, 643, 644, 674, 674, 675, 676, 676, 681, 681, 682, 682, 683, 688, 688, 690, 697, 698, 723, 729, 732, 741, 749, 749, 758, 762, 768, 769, 774, 827, 852, 898.
704. Prophetess of Hathor in all her places, 67, 94, 260, 453, 519, 626, 698.
704A. Prophetess of Hathor foremost of the Temple of Khephren, 302.
705. Prophetess of Hathor in the mert-temple of Unis, 652.
706. Prophetess of Hathor Mistress of Dendera, 54, 148, 207.
707. Prophetess of Hathor Mistress of Dendera in all her places, 309.
708. Prophetess of Hathor Mistress of the Deserts, 72, 118.
709. Prophetess of Hathor Mistress of the Shrine of the Southern Sycamore, 536.
710. Prophetess of Hathor Mistress of the Sycamore, 66, 66, 96, 98, 139, 153, 203, 206, 207, 246, 260, 340, 448, 468, 490, 492, 498, 520, 565, 580, 583, 608, 632, 637, 641, 641, 736, 895, 895.
711. Prophetess of Hathor Mistress of the Sycamore in all her beautiful places, 639.
712. Prophetess of Hathor Mistress of the Sycamore in all her places, 126, 131, 230, 232, 451, 746.
713. Prophetess of Hathor Mistress of the Two Banks of Horus, 676.
714. Prophetess of Hathor North of the Wall (correctly: Prophetess of Hathor), 135.
715. Prophetess of Iput I, 568, 570.
716. Prophetess of Khufu, 72, 200, 216, 490.
717. Prophetess of the mert-temple of Teti, 606.
718. Prophetess of nbty-špsš (nebtj-name of Shepseskaf), 256.
719. Prophetess of Neith, 51, 77, 80, 99, 101, 134, 143, 149, 200, 205, 215, 227, 232, 246, 260, 282, 286, 286, 451, 457, 460, 483, 490, 568, 606, 626, 643, 729, 735, 736, 769, 826.
720. Prophetess of Neith in all her places, 309.
721. Prophetess of Neith foremost of the temple of Khephren, 302.
722. Prophetess of Neith North of her Wall, 498.
723. Prophetess of Neith North of the Wall, 71, 135 (incorrectly as belonging to Hathor), 139, 450, 468, 580, 583, 639, 746.
724. Prophetess of Neith Opener of the Ways, 67, 96, 98, 131, 153, 165, 207, 746.
725. Prophetess of Neith Opener of the Ways in all her pure places, 565.
726. Prophetess of Raʿzedef, 3.
727. Prophetess of Snefru, 895.
728. Prophetess of Thasepēf, 256.
729. Real Chief Justice and Vizier, 508.
730. Real count, 610.
731. Real royal acquaintance, 463.
732. Real royal chamberlain, 742.
733. Recruit, 100, 100, 104, 106, 700.
734. Recruiter of the desert guides of Wenet and of every foreign country(?), 749.
735. Regulator of a phyle, 292, 562, 563, 568, 570, 673.
736. Regulator of a phyle of the Pyramid of Merykarēc, 538, 538, 562, 563, and Addenda.
737. Regulator of a phyle of the Pyramid of Pepy I, 676.
738. Regulator of a phyle of the Pyramid of Shepseskaf, 307, 759.
739. Regulator of a phyle of the Pyramid of Teti, 538, 544, 562.

740. Rower of the bark, 295.
 741. Royal acquaintance, *passim*.
 742. Royal acquaintance of the Great House, 129, 638, 759, 768.
 743. Royal chamberlain, 5, 66, 142, 154, 167, 218, 228, 244, 249, 255, 263, 280, 280, 345, 402, 440, 496, 517, 539, 579, 586, 595, 596, 605, 605, 622, 633, 633, 653, 671, 677, 677, 677, 681, 742, 756, 762.
 744. Royal chamberlain of the Great House, 66, 155, 165, 239, 521, 547.
 745. [cancelled]
 746. Royal scribe, 76, (97 to be deleted), 503.
 747. Scribe, 20, 54, 97 (as Royal scribe in error), 103, 121, 145, 292, 439, 517, 544, 546, 567, 723, 724, 727.
 748. Scribe of the archives, 114, 170, 503, 768.
 749. Scribe of a boat's side, 694, 742.
 750. Scribe of the crews, 275.
 751. Scribe of divine books/writing, 133, 141, 282, 403, 563, 736, 824.
 752. Scribe of the divine treasure in the Temple of Ptah, 746.
 753. Scribe of the documents, 405.
 754. Scribe of enrolment of the crew of the boat, 611. See also Title 778.
 755. Scribe of the expedition, 251, 540, 570.
 756. Scribe of the four divisions of craftsmen, 281.
 757. Scribe of the granary, 129, 176, 272, 296, 458.
 758. Scribe of the Great House, 547.
 759. Scribe of the house of the master of the largesse, 730.
 760. Scribe of the King's expedition in Wenet, Serer, Tapa, and Ida, 501.
 761. Scribe of the new settlements of the Great Estate, 51.
 762. Scribe of petitions, 264.
 763. Scribe of a phyle, 84, 433, 608, 679, 688.
 764. Scribe of a phyle of the endowment of Meḥi (probably Senzemib), 129.
 765. Scribe of a phyle of the endowment of Senzemib, 163.
 766. Scribe of a phyle of the Pyramid of Khufu, 176.
 766A. Scribe of the Pyramid of Merykarē, see Addenda.
 767. Scribe of the Pyramid-town, 567.
 768. Scribe of recruits, 114.
 769. Scribe of the royal documents, 48, 74, 133, 158, 162, 211, 306, 307, 457, 675, 684, 687, 736, 742.
 770. Scribe of the royal documents of the granary, 124, 691.
 771. Scribe of the royal documents of the Great House in the presence, 168.
 772. Scribe of the royal documents in the presence, 158, 161, 167, 250, 582, 605, 677, 688, 891.
 773. Scribe of the royal linen (*šrw*), 243.
 774. Scribe of sacrificial cattle of the slaughter-house of the god, 763.
 775. Scribe of the Treasury, 121, 129, 306.
 776. Scribe of the treasury of the estate 'Mansion of Menkaurē', 298.
 777. Scribe of the treasury of the Pyramid of Merykarē, 562.
 778. Scribe of the troop (*gst*), 768. See Title 754.
 779. Scribe of the Two Granaries, 567.
 780. Sculptor, 197, 282, 543.
 781. Sculptor of the *warbt*, 247.
 782. Seal-bearer, 442.
 783. Sealer of the best provisions of the King of Lower Egypt, 276.
 784. Secretary, 64, 77, 110, 137, 143, 178, 209, 307, 878.
 785. Secretary of all commands of the King, 228, 579.
 786. Secretary of all foreign countries, 565.
 787. Secretary of all secret commands of the King, 223.
 788. Secretary of all works, 627.
 789. Secretary of commissions of the divine offerings, 251.
 790. Secretary of craftsmen, 168.
 791. Secretary of the estates of Neith, 723.
 792. Secretary of every secret judgement of the Great Court, 94.
 793. Secretary of the God's treasure, 567, 732.
 794. Secretary of his Lord, 79, 94, 152, 190, 286.
 795. Secretary of judgement, 68, 115, 222.
 796. Secretary of the jury of the Pyramid of Menkaurē, 294.
 797. Secretary of the King in all his places, 895.
 798. Secretary of the King in all his secrets, 742.
 799. Secretary of the King in the Great House, 145.
 800. Secretary of the King's repast of the Great House, 350.
 801. Secretary of the King's *warbt*, 212.
 802. Secretary of Neferirkarē, 638.
 803. Secretary of the private hearing in the Six Great Courts, 686.
 804. Secretary of the Pyramid of Khephren, 302.
 805. Secretary of the Pyramid of Menkaurē, 311.
 806. Secretary of the royal ḥarīm, 260.
 807. Secretary of the secret judgement of the Great Court, 160, 162.
 808. Secretary of the Toilet-house, 115, 133, 135, 141, 234, 235, 253, 254, 281, 306, 343, 485, 497, 634, 687, 722, 723, 723, 730, 732.
 809. Seer of Horus and Sēth, 136, 273.
 810. *sem*-priest, 78, 125, 270, 318, 480.
 811. 'Servants of the estate of Shepy', 893.
 812. Servant of the Souls of Nekhen, 404.
 813. Servant of the throne, 343.
 814. Singer of the Great House, 105, 761.
 815. 'Sister of the endowment', 485.
 816. *sma*-priest of Anubis, 127, 133.
 817. *sma*-priest of Horus, 742.
 818. Smelter, 768.
 819. Sole companion, *passim*.
 820. Sole companion of his father, 5, 293.
 821. Steward, 62, 65, 92, 108, 114, 129, 154,

II. Hieroglyphic forms

Only one form given. Numbers refer to Section I

Summary:

- | | |
|---|-------------------------------|
| A. Ranks and court | N. Entertainment |
| B. Filiation and relationship | O. Scribes |
| C. Officials of treasuries | P. Judiciary |
| D. Granaries, farming, and husbandry | Q. Various officials |
| E. Endowments and estates | R. Priests and temples |
| F. Tenants | S. Necropolis |
| G. Crafts, trades, and professions | T. Pyramids and pyramid-towns |
| H. Physicians | U. Sun-temples |
| I. Army, expeditions, and police | V. Buildings |
| K. Boats, barks, and dockyards | W. Kings |
| L. Barbers, hairdressers, and manicurists | X. Gods |
| M. Attendants, etc. | Y. People |
| Z. Geographical | |









A. Ranks and court.

| | | | | | |
|-----|-----|-----|-----|-----|-----|
| 39 | 158 | 48 | 873 | 819 | 741 |
| 729 | 730 | 872 | 43 | 820 | 731 |
| 877 | | | 47 | | 742 |
| 366 | | | 44 | | |
| | | | 45 | | |
| 370 | 372 | 371 | 743 | 732 | 744 |
| 828 | 164 | 180 | | 430 | |

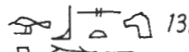
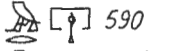
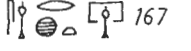
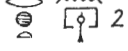
B. Filiation and relationship.

| | | | |
|-----|-----|--------------------|-----|
| 331 | 321 | 338 | 328 |
| 332 | 322 | 46 | 367 |
| 325 | 323 | 809 | 368 |
| 326 | 324 | <u>wrt hts</u> 899 | 315 |
| 115 | | | 53 |
| | | | 54 |

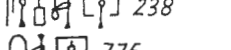
C. Officials of treasuries.

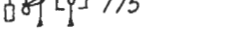













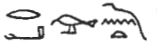

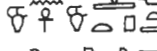







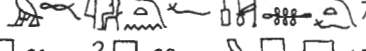

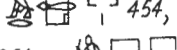

-  605
  601
  131
 590
  167
  2
  854
  233
 593
  238
 595
  775

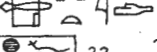
Overseer of the Treasury of Khufu, Raʿzedef, and Snefru, 591, 592, 594

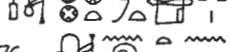



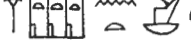
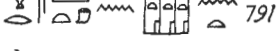
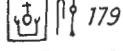
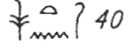



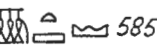

D. Granaries, farming, and husbandry.

-  600
  558
  417
  441
  60
 537
  779
  174
 452
  232
  61
  497
  401
 166
  770
  84
 291
  228
  86
  400
  460
 757
  282
 827
  433
 874
  98
  423
  458

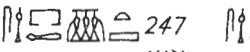
E. Endowments and estates.

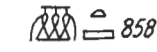
-  22
  815
 Omitting titles of owners:  23
  476
 294
  295
  375
  202
 811
  385
 477
  298
  616
  345
 764
  765
  493
 31
  38
  454, probably same as  822
  583
 264
  110
  376
  761
  377
 32
  37
  776
 68
  791
  179
 40
  33

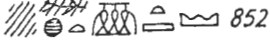
F. Tenants.

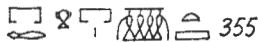
-  428
  427
  586
  585
 277
  247
  246
  859
  858
Imy-ht hnty(w)-š pr-ꜥ3 853
  852
 413
  355

G. Crafts, trades, and professions.

- 418 384 419 175 51 829
- 132 580 790
- 499 363 566
- 500 362 120 *imy-r stw(w) nbw hkr(w)-nsw* 567
- 450 125 93
- 451 127 818
- 82 501 126 364
- 589 94 867 825
- imy-r kd(w)* 395 171 320 319
- 398 399 172 29
- 559 239 561 560 780
- 436 617 11
- 490 342 6 140
- 612 440 392
- 58 21 611 897
- 396 26 and 352 24 25 391

- 468 71 467 734
- 223 62 733
- 782 783 397
- 597 876

- 784 *n k3wt nbt* 788
- 794 799 797
- 798 329
- 785 787
- 786 789 793 800

H. Physicians

- 514 144 141 69
- 195 143 133 118
- 196 424 119
- 618 142 55
- 619 113 1

I

Army, expeditions, and police.

- 435
 103
 831
 755
 760
 57
 506
 620
 836
 292

K

Boats, barks, and dockyards.

- 169
 73
 81 ^{sic?}
 344
 445
 442 ^{sic}
 565
 579
 347
 582
 393
 542
 577
 749
 740
 Inspector of rowers of the bark 224
 421
 754
 870
 871
 869
 302
 102
 273
 431
 27
 465

L

Barbers, hairdressers, and manicurists.

- 390
 351
 187
 496
 327
 150
 70
 75
 184
 181
 459

M

Attendants, etc.

- 316
 330
 317
 318
 183
 193
 194
 483
 484
 508
 4
 309
 509
 299
 300
 190
 65
 808
 Attendant of the Great House 304

N

Entertainment.

- 814
 91
 92
 241
 242
 243
 244
 439
 563
 564
 857
 52
 177
 422
 438
 124
 432
 122
 123
 444
 434

O. Scribes.

747
 85
 226
 543
 758
 746
 286
 276
 281
 285
 753
 769
 231
 554
 772
 771
 555
 556
 237
 557
 539
 538
 7
 311
 541
 540

762
 90
 230
 288
 750
 227
 544
 287
 547
 550
 551
 548
 549
 552
 768
 763
 756
 773
 235
 234
 751
 774
 Inspector of scribes of sacrificial cattle 236
 748
 12
 270
 170
 275
 14
 13
 826











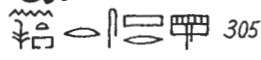
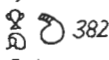



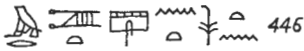

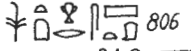
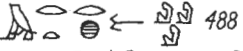

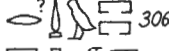

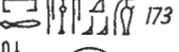
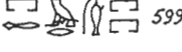
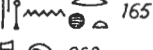

P. Judiciary.

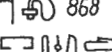
379
 380
 289
 473
 472
 795
 807
 792
 803
 89
 283

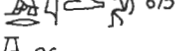
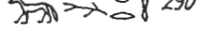
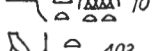
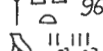
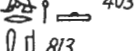



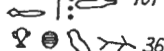









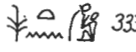
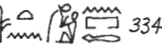
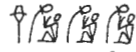
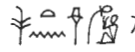



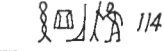

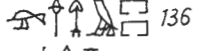
Q. Various officials.

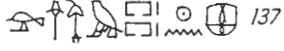
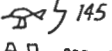
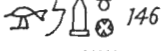
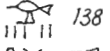
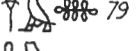
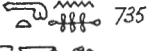
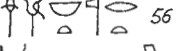
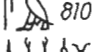
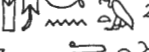
613
 614
 387
 388
 578
 584
 447
 404
 407
 405
 406
 425
 426
 482
 15
 271
 Judge and Boundary official of the Great House 272
 18
 20
 16
 17
 19
 Overseer of the new settlements 503
 534
 429
 95
 598
 30
 360
 280
 188
 358
 835
 192
 507



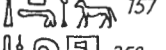

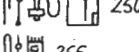
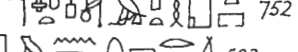

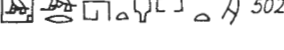
Q. Various officials (contd.)

-  305  382  492
 381
 74  446
 485  806  488  489
 834  306  307  186  449
 173  599
 165 Supervisor of the Two Houses 855  353
 868  562
 265  615  290
 10  96
 403  443  147
 813  101
 8  361 One who is in the magistracy 378

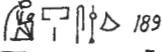
R. Priests and temples.

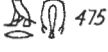
-  621  197  130  894
 878  333  334  99  76  251
 343 Lector-priest of his father 346  41  42  114
 134  136  135  137
 145  146  138
 79  735  56
 810  268  269  155  163  314
 157  313  156
 250  752
 266  502

S. Necropolis.

-  262  609  487  801  781
 471  176  420  581
 189  898  263
 455  457  456
 832  293  182  475  481
 369  608
 116  117  66  67  178

T. Pyramids and pyramid-towns.



524 888 258

604 568 691



imy-r 519 shd hm(w)-ntr 210 337 77 255

553 766 106

495 649 527



480



518 838 hm-ntr 666 883 254 80
804 105 494 shd hnty(w)-š 248

34 856 526



520 212 885
107 imy-r d3d3t 474 hry-sšt3 d3d3t 796 805 867

529



523 738



imy-r [hm(w)-ntr] 517 889 259

630



673 887 257

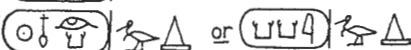

521 841 669 525 881

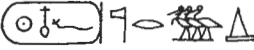

844 672



522 842 670 214

886 256 409 530



839 667 211 884 528

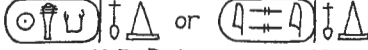

847 665 and 676 209 and 219 882 532

108 504 408 414 860

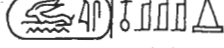

846 675 218 866 411

T

Pyramids and pyramid-towns (contd.)

91 845 91 674 91 217 91 865 91 249 91 588 91 416 91 739 91 220 91 531

91 843 91 671 91 215 91 737 91 35 91 863 91 587 91 415 91 535 91 410

91 840 hm-ntr-668 91 213 91 895 91 862

91 216 91 896 91 267 91 222 91 864 91 36

91 736 91 777 91 766 A 91 870 A

unspecified 91 767

U

Sun-temples.

91 698 91 684 91 261 91 892 91 571 91 260 91 633

91 576 91 683 91 891

91 573 91 849 91 696 91 681 91 221 91 632

(also 91 575)

91 574 91 850 91 682 91 412 91 245

91 848 91 680

V

Buildings.

121 and 821 Mistress of the house 365 91 466 91 109 91 354









































91 112 hrp is 72 91 469 91 470 91 603

91 851 91 569 91 570 91 374

















































91 830 91 63 91 64 91 301 91 512

91 225 91 486 91 336 hry db3t 359 91 511 91 533



V. Buildings (contd.)

- | | | | | | | | | | | | | |
|---|---|---|---|---|---|---|---|---|---|---|---|-----|
|  | 83 |  | 510 |  |  | 373 | | | | | | |
|  |  | 97 |  |  | 356 |  |  | 148 | | | | |
|  | 59 |  |  | 394 |  |  | 87 |  | 104 |  |  | 274 |
|  |  | 453 |  |  | 546 |  |  | 402 | | | | |
|  |  | 536 |  |  | 462 |  |  | 602 |  |  | 461 | |
|  |  | 463 |  |  | 464 |  |  | 303 |  |  |  | 448 |

W. Kings.

- | | | | | | | | | | |
|---|---|--|--|---|---|---|---|---|------|
|  |  | (preceded by  ?), 658 | | | | | | | |
|  |  | 690 and 727 | | | | | | | |
|  |  |  |  |), also  |  | 637, 642, 644, 648, 652, 716 | | | |
|  |  | 678 and 726 | | | | | | | |
|  |  |  |  | 641, 643, 657 |  | 695 |  |  | 704A |
| | | | | |  |  |  | 721 | |
|  |  | 653 |  | 206 |  | 253 | | | |
|  | (i.e. Shepseskaf) |  | 718 | | | | | | |
|  |  | 701 |  | 335 | | | | | |
|  |  | 685 |  | 349 |  | 893 | | | |
|  |  | 659 |  | 348 |  | <u>hry-sšt3</u> 802 | | | |
|  |  | 677 | | | | | | | |
|  |  | 662 |  |  | 160 | | | | |
|  |  |  | (preceded by  ?), 655 | | | | | | |
|  |  |  | 200 |  |  | 705 | | | |
|  |  |  | 837 |  | 717 | | | | |
|  |  |  | 207 |  | <u>shd hm(w)-ntr hwt-k3</u> 204 | | | | |
|  |  |  | 162 | | | | | | |

X. Gods.

- | | | | | | | | | | | |
|---|---|---|---|--|--|--|---|-----|---|-----|
|  |  | 622 |  |  | 623 |  |  | 694 |  | 812 |
|  | 816 |  |  | 389 |  |  | 624 | | | |
|  |  |  | 516 |  |  | 664 |  | 208 | | |
|  |  | 625 |  |  | 626 |  | 651 | | | |
|  |  | 702 |  |  | 656 | | | | | |
|  |  | 663 |  |  | 654 | | | | | |

X. Gods (contd.)

153
 , etc. 660 and 719 720
of
 723 722
 724 725
 661
 679 890
 699
 312
 629 and 703 704
 198 199
of True prophetess of Hathor 875
 710 712 711
 709
 631 and 706 707
 708
 713
 515

154
 203 817
 640 638 636
 639
 635
 634
 645 646
 647
 692 240
 693
 151 350
 100
 687
 689
 686
 728
 628 5
 627
 700

Y. People.

Omitting titles: 297 833 823 824
 715 160A 162A 880
 3 159 ss pr hry-wdb 759 88 229
 650 205 879 252 296 478 479
 III

Z. Geographical.

606 513 149
 28 50 308 278 284 279
 383 341 129 128 167
 339 688 340
 505
 498 386 491 310
 572 596
 437 191

APPENDIXES

H. APIS-BULLS

in this volume

| <i>Apis-bull</i> (numbering of Mariette) | <i>Date</i> | <i>Burial chamber</i> | | <i>Page</i> | |
|---|-------------------------|--|--------------|----------------------|-----|
| | | <i>Mariette</i> | <i>Rhoné</i> | | |
| <i>Dyn. XVIII</i> | | | | | |
| I | I | Amenophis III | A | C ₁ | 780 |
| II | V | probably Dyn. XVIII | B | C ₂ | 781 |
| III | II | Tut ^{ank} hamūn | C | C ₃ | 781 |
| IV and V | III and IV | Ḥaremḥab | D and E | C ₄ and 5 | 781 |
| <i>Dyn. XIX</i> | | | | | |
| VI | I | Sethos I | F | C ₆ | 782 |
| VII and IX | II and IV | years 16 and 30 of Ramesses II | G | C ₈ | 782 |
| X-XIV | V-IX | Ramesses II | I, J, K | D, D | 784 |
| <i>Dyn. XX</i> | | | | | |
| XVI | II | Ramesses VI | | | 785 |
| XVII | III | Ramesses IX | M | E' | 785 |
| <i>Dyn. XXII</i> | | | | | |
| XXVII | I | year 23 of Osorkon II | | | 785 |
| XXVIII | II | year 14 of Takelothis II | | | 785 |
| XXIX | III | year 28 of Sesonchis III | P | F | 786 |
| XXX | IV | year 2 of Pemu | | | 786 |
| XXXI | V | ? (Mariette: year 4 of Sesonchis V) | Q | F' | 787 |
| XXXII | VI | year 11 of Sesonchis V | | | 787 |
| XXXIII | VII | year 37 of Sesonchis V | R | F'' | 787 |
| <i>Dyn. XXIV</i> | | | | | |
| XXXIV = XXXV | I (= I of Dyn. XXV) | year 6 of Bocchoris = year 2 of Sabacon | S | G | 789 |
| <i>Dyn. XXV</i> | | | | | |
| XXXVI | I (= I of Dyn. XXIV) | | | | |
| | II | year 24 of Taharqa | (T') | (H*) | 791 |
| <i>Dyn. XXVI</i> | | | | | |
| XXXVII | I | years 20/21 of Psammetikhos I | T | H | 791 |
| XXXVIII | II | year 52 of Psammetikhos I | U | I | 797 |
| XXXIX | III | year 16 of Necho II | V | J | 797 |
| XL | IV | year 12 of Apries | X | K | 797 |
| XLI | V | year 23 of Amasis | Y | L | 797 |
| <i>Dyn. XXVII</i> | | | | | |
| XLII | | year 6 of Cambyses | Z | M | 799 |
| XLIII | | year 34 of Darius I | A' | N | 800 |
| XLIV | | year 4 of Darius I | B' | N' | 799 |
| XLV | | Darius I | C' | N'' | 800 |
| <i>Dyn. XXIX</i> | | | | | |
| unnumbered | | year 2 of Nepheritis I | | | 804 |

| <i>Apis-bull</i> (numbering of Mariette) | <i>Date</i> | <i>Burial chamber</i> | | <i>Page</i> |
|---|---|-----------------------|---------------------|-------------|
| | | <i>Mariette</i> | <i>Rhone'</i> | |
| | <i>contemporary with Dyn. XXXI</i> | | | |
| XLVI | year 2 of Khebebesb | D' | O | 804 |
| | <i>Ptolemaic</i> | | | |
| LV | year 17 of Ptolemy VI Philometor | | P (2nd on right) | 804 |
| LVII | year 52 of Ptolemy VIII Euergetes II | | | 804 |
| unnumbered | unknown | | R | 804 |

I. APIS-STELAE IN THE LOUVRE

Only those mentioned in this volume

| <i>C No.</i> | <i>Page</i> | <i>IM No.</i> | <i>Page</i> | <i>IM. No.</i> | <i>Page</i> |
|----------------|-------------|---------------|-------------|----------------|-------------|
| 316 | 812 | 2660 | 806 | 2768 | 793 |
| 317 | 802 | 2661 | 809 | 2775 | 808 |
| | | 2662 | 794 | 2782 | 808 |
| <i>IM. No.</i> | <i>Page</i> | 2663 | 795 | 2784 | 808 |
| 3 | 813 | 2665 | 794 | 2785 | 809 |
| 6 | 812 | 2666 | 796 | 2787 | 794 |
| 16 | 812 | 2672 | 809 | 2788 | 795 |
| 19 | 805 | 2673 | 791 | 2789 | 795 |
| 36 | 814 | 2675 | 791 | 2795 | 809 |
| 37 | 814 | 2676 | 792 | 2796 | 795 |
| 38 | 807 | 2679 | 790 | 2797 | 796 |
| 42 | 803 | 2680 | 789 | 2799 | 808 |
| 43 | 814 | 2681 | 793 | 2802 | 796 |
| 47 | 814 | 2682 | 789 | 2807 | 809 |
| 64 | 798 | 2685 | 793 | 2809 | 808 |
| 78 | 814 | 2686 | 807 | 2810 | 786 |
| 129 | 814 | 2689 | 793 | 2815 | 795 |
| 132 | 797 | 2690 | 788 | 2819 | 792 |
| 133 | 797 | 2692 | 790 | 2821 | 807 |
| 136 | 815 | 2693 | 796 | 2846 | 788 |
| 137 | 803 | 2699 | 794 | 2847 | 790 |
| 138 | 803 | 2702 | 787 | 2849 | 805 |
| 139 | 814 | 2703 | 793 | 2853 | 794 |
| 176 | 813 | 2704 | 789 | 2854 | 795 |
| 1244 | 801 | 2705 | 791 | 2856 | 792 |
| 1805 | 796 | 2706 | 794 | 2857 | 803 |
| 2619 | 793 | 2707 | 791 | 2858 | 795 |
| 2620 | 792 | 2709 | 795 | 2859 | 796 |
| 2621 | 793 | 2710 | 810 | 2860 | 810 |
| 2623 | 793 | 2717 | 808 | 2861 | 795 |
| 2624 | 793 | 2718 | 789 | 2862 | 810 |
| 2631 | 807 | 2724 | 809 | 2863 | 790 |
| 2634 | 795 | 2726 | 795 | 2864 | 810 |
| 2637 | 806 | 2728 | 795 | 2865 | 805 |
| 2640 | 791 | 2732 | 791 | 2866 | 794 |
| 2642 | 794 | 2734 | 793 | 2867 | 792 |
| 2645 | 811 | 2735 | 790 | 3008 | 806 |
| 2650 | 795 | 2740 | 793 | 3009 | 792 |
| 2651 | 811 | 2746 | 791 | 3010 | 809 |
| 2653 | 790 | 2757 | 790 | 3011 | 797 |
| 2656 | 793 | 2762 | 809 | 3012 | 789 |
| 2658 | 795 | 2763 | 791 | 3016 | 806 |
| 2659 | 791 | 2764 | 794 | 3017 | 796 |

| <i>IM. No.</i> | <i>Page</i> | <i>IM. No.</i> | <i>Page</i> | <i>IM. No.</i> | <i>Page</i> |
|----------------|-------------|----------------|-------------|----------------|-------------|
| 3019 | 807 | 3092 | 789 | 3440 | 807 |
| 3020 | 810 | 3093 | 805 | 3441 | 786 |
| 3022 | 807 | 3095 | 811 | 3442 | 796 |
| 3023 | 793 | 3096 | 811 | 3574 | 794 |
| 3024 | 806 | 3097 | 809 | 3577 | 810 |
| 3025 | 807 | 3098 | 811 | 3579 | 794 |
| 3027 | 793 | 3099 | 815 | 3580 | 790 |
| 3028 | 809 | 3100 | 807 | 3582 | 795 |
| 3029 | 794 | 3101 | 807 | 3586 | 810 |
| 3030 | 809 | 3102 | 809 | 3587 | 809 |
| 3031 | 794 | 3103 | 806 | 3588 | 810 |
| 3032 | 805 | 3104 | 794 | 3591 | 794 |
| 3033 | 806 | 3105 | 794 | 3592 | 789 |
| 3034 | 787 | 3106 | 790 | 3595 | 788 |
| 3035 | 790 | 3107 | 805 | 3689 | 812 |
| 3036 | 790 | 3108 | 795 | 3697 | 786 |
| 3037 | 790 | 3109 | 809 | 3717 | 812 |
| 3038 | 796 | 3110 | 787 | 3719 | 787 |
| 3039 | 793 | 3111 | 811 | 3721 | 789 |
| 3040 | 814 | 3112 | 795 | 3727 | 795 |
| 3041 | 796 | 3113 | 790 | 3728 | 789 |
| 3042 | 796 | 3114 | 799 | 3729 | 813 |
| 3043 | 792 | 3116 | 810 | 3732 | 814 |
| 3045 | 793 | 3117 | 807 | 3733 | 792 |
| 3046 | 793 | 3118 | 790 | 3736 | 786 |
| 3047 | 803 | 3123 | 807 | 3745 | 805 |
| 3048 | 795 | 3127 | 807 | 3747 | 784 |
| 3049 | 787 | 3128 | 806 | 3749 | 786 |
| 3050 | 789 | 3129 | 792 | 3756 | 790 |
| 3051 | 806 | 3130 | 793 | 3757 | 794 |
| 3053 | 794 | 3131 | 799 | 3758 | 813 |
| 3054 | 789 | 3132 | 794 | 3760 | |
| 3056 | 807 | 3133 | 808 | (probably) | 808 |
| 3057 | 794 | 3134 | 794 | 3999 | 801 |
| 3058 | 809 | 3135 | 810 | 4000 | 804 |
| 3059 | 805 | 3136 | 811 | 4001 | 803 |
| 3060 | 807 | 3139 | 810 | 4002 | 798 |
| 3061 | 787 | 3141 | 806 | 4003 | 802 |
| 3062 | 793 | 3142 | 795 | 4004 | 803 |
| 3063 | 794 | 3143 | 788 | 4005 | 814 |
| 3064 | 808 | 3144 | 808 | 4006 | 815 |
| 3065 | 806 | 3145 | 813 | 4008 | 801 |
| 3067 | 793 | 3146 | 807 | 4009 | 798 |
| 3068 | 789 | 3148 | 798 | 4010 | 814 |
| 3070 | 810 | 3302 | 807 | 4011 | 802 |
| 3071 | 796 | 3304 | 796 | 4012 | 813 |
| 3072 | 792 | 3305 | 806 | 4013 | 799 |
| 3075 | 794 | 3306 | 791 | 4015 | 813 |
| 3076 | 792 | 3307 | 795 | 4016 | 800 |
| 3077 | 793 | 3308 | 808 | 4017 | 799 |
| 3078 | 788 | 3311 | 806 | 4018 | 800 |
| 3079 | 788 | 3312 | 810 | 4019 | 798 |
| 3080 | 809 | 3316 | 808 | 4020 | 812 |
| 3081 | 806 | 3318 | 794 | 4021 | 804 |
| 3082 | 792 | 3345 | 812 | 4022 | 815 |
| 3083 | 806 | 3424 | 789 | 4025 | 802 |
| 3084 | 788 | 3426 | 807 | 4026 | 814 |
| 3085 | 788 | 3427 | 787 | 4027 | 803 |
| 3087 | 792 | 3428 | 795 | 4029 | 802 |
| 3088 | 806 | 3429 | 805 | 4030 | 812 |
| 3089 | 792 | 3431 | 814 | 4032 | 802 |
| 3090 | 785 | 3432 | 787 | 4033 | 801 |
| 3091 | 789 | 3439 | 808 | 4034 | 798 |

Apis-stelae in the Louvre

943

| <i>IM. No.</i> | <i>Page</i> | <i>IM. No.</i> | <i>Page</i> | <i>IM. No.</i> | <i>Page</i> |
|----------------|-------------|----------------|-------------|----------------|-------------|
| 4037 | 800 | 4113 | 811 | 5427 | 814 |
| 4038 | 801 | 4114 | 804 | 5428 | 796 |
| 4039 | 800 | 4115 | 813 | 5432 | 806 |
| 4040 | 798 | 4116 | 800 | 5936 | 784 |
| 4041 | 813 | 4117 | 814 | 5937 | 805 |
| 4042 | 810 | 4118 | 800 | 5939 | 790 |
| 4043 | 812 | 4119 | 812 | 5941 | 810 |
| 4044 | 803 | 4120 | 802 | 5943 | 815 |
| 4045 | 800 | 4121 | 802 | 5944 | 795 |
| 4046 | 800 | 4122 | 814 | 5945 | 796 |
| 4047 | 814 | 4123 | 814 | 5947 | 790 |
| 4050 | 802 | 4125 | 801 | 5948 | 790 |
| 4051 | 798 | 4126 | 811 | 5949 | 810 |
| 4052 | 803 | 4127 | 814 | 5952 | 783 |
| 4053 | 798 | 4128 | 799 | 5953 | 784 |
| 4054 | 799 | 4129 | 800 | 5954 | 783 |
| 4055 | 804 | 4131 | 797 | 6153 | 784 |
| 4056 | 802 | 4133 | 799 | | |
| 4057 | 800 | 4134 | 802 | <i>N. No.</i> | <i>Page</i> |
| 4058 | 793 | 4135 | 813 | 403 | 792 |
| 4060 | 802 | 4149 | 802 | 404 | 797 |
| 4061 | 815 | 4150 | 803 | 405 | 797 |
| 4062 | 811 | 4162 | 791 | 406 | 797 |
| 4063 | 800 | 4163 | 815 | 407 | 799 |
| 4065 | 810 | 4167 | 812 | 408 | 799 |
| 4066 | 812 | 4168 | 808 | 409 | 804 |
| 4067 | 811 | 4169 | 803 | 410 | 804 |
| 4068 | 800 | 4170 | 798 | 411 | 783 |
| 4069 | 803 | 4174 | 798 | 412 | 784 |
| 4071 | 813 | 4175 | 798 | 413 | 786 |
| 4072 | 801 | 4187 | 799 | 414 | 786 |
| 4073 | 812 | 4188 | 799 | 417 | 791 |
| 4074 | 798 | 4189 | 811 | 418 | 811 |
| 4075 | 813 | 4190 | 803 | 419 | 787 |
| 4076 | 800 | 4191 | 814 | 421 | 790 |
| 4077 | 802 | 4192 | 798 | 421 | 811 |
| 4079 | 812 | 4193 | 810 | 421/1 | 807 |
| 4080 | 802 | 4198 | 812 | 421/12 | 811 |
| 4082 | 813 | 4205 | 786 | 421/16 | 806 |
| 4083 | 813 | 4207 | 801 | 421/31 | 807 |
| 4084 | 811 | 4208 | 790 | 421/32 | 808 |
| 4085 | 813 | 4209 | 814 | 421/35 | 787 |
| 4086 | 799 | 4210 | 814 | 421/36 | 787 |
| 4087 | 801 | 4213 | 802 | 421/37 | 806 |
| 4089 | 811 | 4214 | 801 | 421/38 (sic) | 790 |
| 4091 | 814 | 4215 | 805 | 421/38 (sic) | 805 |
| 4092 | 804 | 4216 | 814 | 421/39 | 791 |
| 4095 | 803 | 4217 | 811 | 421/44 | 808 |
| 4097 | 801 | 4218 | 810 | 421/46 | 806 |
| 4098 | 803 | 4244 | 815 | 421/48 | 806 |
| 4099 | 802 | 4246 | 804 | 421/50 | 808 |
| 4100 | 799 | 4963 | 783 | 421/51 | 807 |
| 4101 | 804 | 4964 | 783 | 421/52 | 808 |
| 4103 | 804 | 5268 | 783 | 421/57 | 807 |
| 4104 | 800 | 5269 | 784 | 421/59 | 807 |
| 4105 | 814 | 5270 | 783 | 421/63 | 805 |
| 4106 | 812 | 5271 | 783 | 421/64 | 806 |
| 4107 | 803 | 5305 | 781 | 421/65 | 806 |
| 4108 | 811 | 5306 | 781 | 421/74 | 806 |
| 4109 | 801 | 5307 | 781 | 421/77 | 789 |
| 4110 | 798 | 5341 | 802 | 421/94 | 806 |
| 4111 | 802 | 5342 | 794 | 421/97 | 808 |
| 4112 | 812 | 5343 | 811 | 421/107 | 790 |

| <i>N. No.</i> | <i>Page</i> | <i>N. No.</i> | <i>Page</i> | <i>N. No.</i> | <i>Page</i> |
|---------------|-------------|---------------|-------------|-----------------|-------------|
| 421/111 | 792 | 421/476 | 800 | 677 (sic) | 813 |
| 421/112 | 791 | 421/522 | 811 | 677 (sic) | 814 |
| 421/115 | 796 | 421/526 | 812 | 677 (sic) | 815 |
| 421/118 | 791 | 421/564 | 804 | 679 (sic) | 790 |
| 421/120 | 796 | 421/570 | 811 | 679 (sic) | 790 |
| 421/127 | 793 | 421/579 | 813 | 679 (sic) | 796 |
| 421/132 | 796 | 421/593 | 802 | 679 (sic) | 802 |
| 421/137 | 795 | 421/598 | 802 | 679 (sic) | 805 |
| 421/150 | 810 | 421/601 | 813 | 679 (sic) | 806 |
| 421/156 | 793 | 421/605 | 812 | 679 (sic) | 807 |
| 421/221 | 792 | 421/606 | 807 | 679 (sic) | 811 |
| 421/244 | 794 | 421/613 | 813 | 679/3094 | 815 |
| 421/254 | 795 | 421/614 | 801 | 3417 | 792 |
| 421/256 | 794 | 421/620 | 812 | 5417 | 792 |
| 421/258 | 795 | 421/626 | 803 | 5419 | 785 |
| 421/260 | 795 | 421/644 | 812 | 5442 (sic) | 790 |
| 421/263 | 794 | 421/647 | 803 | 5442 (sic) | 809 |
| 421/264 | 796 | 421/648 | 814 | 5442/4130 | 810 |
| 421/271 | 810 | 421/652 | 800 | <i>E. No.</i> | <i>Page</i> |
| 421/272 | 794 | 421/658 | 814 | 3012 | 781 |
| 421/279 | 795 | 421/660 | 803 | 3335 | 797 |
| 421/284 | 790 | 421/662 | 813 | 3866 | 804 |
| 421/285 | 808 | 421/676 | 804 | 5639 | 794 |
| 421/287 | 793 | 421/697 | 802 | 6246 | 813 |
| 421/289 | 793 | 421/698 | 813 | 10529 | 796 |
| 421/292 | 793 | 421/701 | 801 | <i>S.N. No.</i> | <i>Page</i> |
| 421/293 | 794 | 421/704 | 803 | 1 | 812 |
| 421/296 | 795 | 441 (sic) | 800 | 2 | 806 |
| 421/297 | 792 | 441 (sic) | 801 | 10 | 815 |
| 421/299 | 794 | 441a | 800 | 16 | 808 |
| 421/303 | 810 | 444 | 803 | 22 | 789 |
| 421/307 | 811 | 454 | 791 | 24 | 793 |
| 421/309 | 789 | 469 | 787 | 31 | 801 |
| 421/317 | 799 | 471 | 789 | 43 | 809 |
| 421/321 | 808 | 475 | 800 | 47 | 813 |
| 421/324 | 812 | 476 (sic) | 789 | 48 | 810 |
| 421/327 | 799 | 476 (sic) | 793 | 50 | 813 |
| 421/328 | 811 | 479 | 798 | 52 | 808 |
| 421/331 | 798 | 481 (sic) | 788 | 54 | 792 |
| 421/338 | 796 | 481 (sic) | 803 | 55 | 802 |
| 421/339 | 811 | 485 (sic) | 792 | 56 | 808 |
| 421/342 | 798 | 485 (sic) | 792 | 58 | 805 |
| 421/344 | 811 | 485 (sic) | 793 | 59 | 793 |
| 421/346 | 797 | 485 (sic) | 801 | 60 | 808 |
| 421/347 | 801 | 486 | 798 | 62 | 814 |
| 421/350 | 798 | 488 | 788 | 63 | 794 |
| 421/355 | 799 | 677 (sic) | 790 | 64 | 801 |
| 421/366 (sic) | 802 | 677 (sic) | 790 | 70 | 808 |
| 421/366 (sic) | 802 | 677 (sic) | 790 | 72 | 801 |
| 421/382 | 801 | 677 (sic) | 790 | 74 | 800 |
| 421/383 | 802 | 677 (sic) | 794 | 75 | 796 |
| 421/390 | 802 | 677 (sic) | 801 | 78 | 809 |
| 421/393 | 802 | 677 (sic) | 802 | 79 | 813 |
| 421/394 | 803 | 677 (sic) | 802 | 81 | 783 |
| 421/397 | 802 | 677 (sic) | 803 | 82 | 785 |
| 421/398 | 803 | 677 (sic) | 807 | 83 | 799 |
| 421/399 | 803 | 677 (sic) | 808 | 84 | 784 |
| 421/402 | 800 | 677 (sic) | 808 | 88 | 799 |
| 421/403 | 803 | 677 (sic) | 809 | <i>A.F. No.</i> | <i>Page</i> |
| 421/404 | 814 | 677 (sic) | 809 | 122 | 786 |
| 421/408 | 815 | 677 (sic) | 810 | | |
| 421/411 | 815 | 677 (sic) | 810 | | |
| 421/473 | 814 | 677 (sic) | 810 | | |

Apis-stelae in the Louvre

| <i>A.F. No.</i> | <i>Page</i> | <i>S. No.</i> | <i>Page</i> | <i>S. No.</i> | <i>Page</i> |
|-----------------|-------------|---------------|-------------|---------------|-------------|
| 123 | 788 | 2077 | 794 | 2648 | 793 |
| 124 | 787 | 2079 | 794 | 2661 | 807 |
| 125 | 781 | 2082 | 792 | 2914 | 805 |
| | | 2083 | 810 | 2928 | 807 |
| <i>S. No.</i> | <i>Page</i> | 2085 | 810 | 4045 | 814 |
| 993 | 814 | 2089 | 793 | <i>No.</i> | <i>Page</i> |
| 1006 | 813 | 2090 | 795 | 1 | 781 |
| 1093 | 805 | 2091 | 796 | 2 | 781 |
| 1168 | 781 | 2092 | 794 | 3 | 783 |
| 1169 | 781 | 2093 (sic) | 794 | 4 | 784 |
| 1170 | 781 | 2093 (sic) | 795 | 5 | 784 |
| 1457 | 783 | 2097 | 796 | 6 | 783 |
| 1465 | 783 | 2100 | 793 | 7 | 784 |
| 1466 | 783 | 2101 | 794 | 8 | 784 |
| 1555 | 784 | 2104 | 793 | 9 | 784 |
| 1883 | 785 | 2105 | 793 | 10 | 783 |
| 1885 | 795 | 2106 | 792 | 11 | 783 |
| 1888 | 809 | 2109 | 793 | 12 | 783 |
| 1889 (sic) | 807 | 2125 | 810 | 13 | 783 |
| 1889 (sic) | 813 | 2127 | 794 | 14 | 783 |
| 1890 (sic) | 786 | 2128 | 794 | 15 | 784 |
| 1890 (sic) | 805 | 2131 | 793 | 16 | 783 |
| 1890 (sic) | 815 | 2134 | 795 | 17 | 806 |
| 1892 | 794 | 2139 | 796 | 18 | 786 |
| 1895 | 806 | 2142 | 796 | 19 | 805 |
| 1898 | 786 | 2144 | 811 | 20 | 810 |
| 1903 | 806 | 2146 | 796 | 21 | 786 |
| 1904 | 786 | 2151 | 794 | 22 | 807 |
| 1905 | 786 | 2152 | 794 | 23 | 806 |
| 1906 | 786 | 2159 | 793 | 24 | 809 |
| 1907 | 786 | 2166 | 793 | 25 | 806 |
| 1929 | 787 | 2168 | 794 | 26 | 806 |
| 1933 (sic) | 787 | 2172 | 793 | 27 | 805 |
| 1933 (sic) | 809 | 2173 | 795 | 28 | 807 |
| 1951 | 805 | 2178 | 792 | 32 | 805 |
| 1959 | 788 | 2179 | 795 | 33 | 805 |
| 1977 | 787 | 2186 | 795 | 34 | 786 |
| 1982 | 810 | 2189 | 809 | 35 | 786 |
| 1995 | 789 | 2190 | 809 | 36 | 786 |
| 2009 | 790 | 2196 | 795 | 37 | 787 |
| 2016 | 810 | 2197 | 794 | 38 | 787 |
| 2018 | 791 | 2198 (sic) | 790 | 39 | 809 |
| 2025 | 809 | 2198 (sic) | 809 | 40 | 788 |
| 2027 | 792 | 2199 | 809 | 41 | 805 |
| 2035 | 792 | 2200 | 795 | 42 | 796 |
| 2038 | 793 | 2209 | 810 | 43 | 807 |
| 2041 | 793 | 2211 | 810 | 44 | 805 |
| 2046 | 793 | 2213 | 794 | 45 | 808 |
| 2048 | 793 | 2214 | 795 | 46 | 808 |
| 2050 | 794 | 2216 | 810 | 47 | 806 |
| 2054 | 796 | 2218 | 809 | 48 | 807 |
| 2055 | 793 | 2222 | 808 | 49 | 807 |
| 2056 | 792 | 2226 | 808 | 51 | 807 |
| 2057 | 793 | 2227 | 810 | 52 | 806 |
| 2059 | 795 | 2243 | 797 | 53 | 805 |
| 2063 | 795 | 2244 | 797 | 54 | 809 |
| 2064 | 795 | 2252 | 798 | 55 | 808 |
| 2065 | 793 | 2254 | 811 | 56 | 807 |
| 2067 | 794 | 2259 | 797 | 57 | 808 |
| 2068 | 795 | 2274 | 799 | 58 | 787 |
| 2069 | 794 | 2278 | 810 | 59 | 787 |
| 2072 | 793 | 2287 | 799 | 60 | 806 |
| 2073 | 794 | 2303 | 801 | | |

| <i>No.</i> | <i>Page</i> | <i>No.</i> | <i>Page</i> | <i>No.</i> | <i>Page</i> |
|------------|-------------|------------|-------------|------------|-------------|
| 61 | 791 | 133 | 795 | 227 | 794 |
| 62 | 787 | 136 | 796 | 228 | 810 |
| 64 | 808 | 137 | 795 | 229 | 809 |
| 65 | 806 | 138 | 810 | 230 | 794 |
| 66 | 807 | 139 | 793 | 231 | 796 |
| 67 | 808 | 142 | 795 | 232 | 792 |
| 68 | 808 | 143 | 813 | 233 | 796 |
| 69 | 806 | 144 | 810 | 234 | 793 |
| 70 | 807 | 148 | 795 | 235 | 813 |
| 72 | 809 | 149 | 793 | 237 | 795 |
| 73 | 806 | 150 | 793 | 238 | 793 |
| 74 | 806 | 154 | 810 | 239 | 797 |
| 75 | 788 | 155 | 794 | 240 | 797 |
| 76 | 789 | 156 | 794 | 241 | 793 |
| 77 | 788 | 158 | 794 | 242 | 809 |
| 78 (sic) | 789 | 160 | 794 | 245 | 795 |
| 78 (sic) | 814 | 161 | 793 | 246 | 809 |
| 79 | 789 | 162 | 793 | 247 | 793 |
| 80 | 788 | 163 | 796 | 248 | 795 |
| 81 | 806 | 164 | 795 | 249 | 792 |
| 82 | 806 | 165 | 794 | 250 | 792 |
| 83 | 788 | 166 | 792 | 251 | 814 |
| 84 | 808 | 167 | 796 | 252 | 796 |
| 85 | 788 | 168 | 794 | 255 | 796 |
| 86 | 807 | 169 | 794 | 257 | 796 |
| 87 | 789 | 172 | 808 | 258 | 793 |
| 88 | 807 | 173 | 808 | 259 | 794 |
| 89 | 805 | 176 | 793 | 260 | 811 |
| 90 | 791 | 178 | 795 | 261 | 815 |
| 91 | 789 | 179 | 795 | 264 | 796 |
| 92 | 810 | 184 | 795 | 265 | 796 |
| 93 | 805 | 185 | 794 | 266 | 798 |
| 94 | 805 | 186 | 794 | 268 | 807 |
| 95 | 806 | 187 | 809 | 269 | 810 |
| 96 | 805 | 188 | 791 | 270 | 794 |
| 98 | 790 | 189 | 811 | 271 | 795 |
| 99 | 806 | 190 | 792 | 273 | 792 |
| 100 | 789 | 191 | 793 | 274 | 795 |
| 102 | 809 | 192 | 797 | 275 | 794 |
| 103 | 808 | 193 | 797 | 276 | 795 |
| 104 | 790 | 194 | 794 | 277 | 795 |
| 105 | 808 | 195 | 807 | 278 | 794 |
| 106 | 790 | 199 | 796 | 280 | 810 |
| 107 | 790 | 200 | 808 | 281 | 794 |
| 108 | 790 | 201 | 790 | 284 | 794 |
| 110 | 789 | 202 | 793 | 285 | 792 |
| 111 | 807 | 204 | 814 | 287 | 810 |
| 112 | 789 | 205 | 808 | 288 | 793 |
| 113 | 790 | 208 | 792 | 290 | 808 |
| 114 | 789 | 209 | 811 | 291 | 803 |
| 115 | 789 | 211 | 795 | 292 | 809 |
| 116 | 790 | 213 | 791 | 293 | 795 |
| 117 | 790 | 214 | 809 | 294 | 792 |
| 118 | 790 | 215 | 809 | 295 | 806 |
| 119 | 785 | 216 | 793 | 296 | 811 |
| 120 | 789 | 218 | 794 | 299 | 790 |
| 121 | 791 | 219 | 802 | 301 | 794 |
| 123 | 791 | 220 | 796 | 303 | 794 |
| 124 | 787 | 221 | 792 | 304 | 810 |
| 126 | 796 | 223 | 809 | 306 | 811 |
| 127 | 796 | 224 | 795 | 307 | 795 |
| 128 | 793 | 225 | 794 | 308 | 795 |
| 129 | 795 | 226 | 810 | 309 | 793 |

Apis-stelae in the Louvre

947

| <i>No.</i> | <i>Page</i> | <i>No.</i> | <i>Page</i> | <i>No.</i> | <i>Page</i> |
|------------|-------------|------------|-------------|------------|-------------|
| 310 | 809 | 365 | 798 | 427 | 812 |
| 316 | 793 | 366 | 799 | 428 | 802 |
| 317 | 794 | 374 | 801 | 430 | 790 |
| 318 | 795 | 378 | 809 | 435 | |
| 321 | 811 | 383 | 802 | (probably) | 811 |
| 322 | 798 | 388 | 787 | 439 | 809 |
| 323 | 790 | 390 | 801 | 440 | 815 |
| 325 | 798 | 391 | 803 | 441 | 803 |
| 327 | 813 | 394 | 800 | 442 | 813 |
| 328 | 789 | 398 | 801 | 443 | 800 |
| 329 | 810 | 399 | 802 | 444 | 802 |
| 330 | 799 | 401 | 803 | 445 | 803 |
| 333 | 798 | 402 | 803 | 446 | 801 |
| 336 | 798 | 404 | 801 | 447 | 804 |
| 337 | 797 | 405 | 802 | 448 | 803 |
| 338 | 811 | 406 | 802 | 449 | 811 |
| 339 | 800 | 407 | 802 | 451 | 804 |
| 344 | 811 | 408 | 814 | 458 | 804 |
| 348 | 811 | 409 | 803 | 463 | 803 |
| 349 | 799 | 410 | 802 | 464 | 813 |
| 350 | 798 | 413 | 803 | 470 | 802 |
| 352 | 811 | 417 | 800 | 471 | 801 |
| 353 | 794 | 420 | 813 | 472 | 802 |
| 354 | 799 | 421 | 802 | 473 | 812 |
| 357 | 799 | 422 | 794 | 474 | 803 |
| 359 | 799 | 423 | 814 | 485 | 802 |
| 362 | 800 | 424 | 798 | 503 | 798 |
| 364 | 801 | 425 | 814 | | |

INDEXES

I. KINGS

- Achoris (Khnumma^cetrē^c). Statue, 864. Architrave, 671. Block, 839.
- ‘Aḥa. Vessels, 442, 444, 773. Sealings, 444. Time of, 443.
- Amasis (Khnebrē^c). Chapel, 840. Statue, 864. Stelae, 870, 870. Shrines dedicated by, 824, 824, 874. Block-stand, 842. Blocks, 851, 874. Sistra, 875. Aegis, 820. Plaque, 831. Sealing, 875. In scenes on jambs, 874. In titles, 591, 800, 813. Time of, 648, 649, 649, 650, 670, 740, 797, 798, 798, 799, 811, 811, 827, 831, 844, 867, 867. Sons, Pasenenkhons, Psammethēk; *see* Index 2.
- Amenemhēt I (Seḥetepebrē^c). Offering-table, 862. Pyramid of, in title, 551. Time of, 550.
- Amenemhēt II (Nubkaurē^c). Pyramid-complex, 885. Lintel-fragment, 851. Blocks, 885. Mentioned on block, 571. Cartouche on trial-piece, 880. Man called after, 687. Time of, 686, 886, 886, 886. Wife, Keminub; son, Amenemhēt^cankh; daughters, Iti, Itiwert, Khnemt; *see* Index 2.
- Amenemhēt III (Nima^cetrē^c). Pyramid-complex, 887. Statue, 837. Female sphinxes with name of, 868. Pyramidion, 888. Lintel, 836. Jamb-fragment, 890. Pectoral, 884. Bracelet slides, 884. Sealing, 888. Time of, 725. Wife, Khnemt-neferhezēt-^cat; *see* Index 2.
- Amenemhēt (unspecified). Man called after, 687.
- Amenemnesut (Neferkarē^c). Name on block, 751.
- Amenemōpet (Userma^cetrē^c-setepenamūn). In scene, 850.
- Amenophis I (Zeserkarē^c). Cylinder seal, 557. Hieratic graffiti, time of, 412. Text of (?), 845. (Name recently added to torso, 866.)
- Amenophis II (‘Akheperurē^c). Statue, 863. Stela, 846. In scene on stela, 849. Time of, 737.
- Amenophis III (Nebma^cetrē^c). Chapel, 840. Statues, 826, 827, 840, 863. Block, 844. Kohl-tube, 689. Model axe, 829. In scenes, 780, 843 (stela). In title, 712. Time of, 557, 702, 705, 706, 712, 718, 721, 721, 725, 725, 725, 727, 737, 737, 740, 742, 752, 775, 780, 831, 833, 835, 836, 848, 849, 849. Son, Dhutmosi; *see* Index 2.
- Amenophis IV (Neferkheperurē^c-wa^cenrē^c). Statues, 858, 863. Blocks, time of, 839, 844, 850, 850, 862, 872. Ring, 717. Time of, 562, 666, 737, 775.
- Ameny-Ḳemau. Pyramid, 890.
- Amosis (Nebpeḥtirē^c). Mentioned in text, 554.
- Apophis II (‘Aḳenenrē^c). Vessel, 874.
- Apophis III (Nebkhepeshrē^c). Cartouches on dagger, 552.
- Apries (Ha^cetrē^c-Weḥebrē^c). Palace, 830. Statue, 864. Stelae, 840, 872. Column-fragment, 830. Jar dedicated to Apis, 820. In scenes on stelae, 819, 823. Time of, 587, 588, 797, 838, 848, 849, 867.
- Augustus. Time of, 744, 744.
- Awibrē^c I (Hor). Tomb, 888.
- Ay (Kheperkheperurē^c). Block, 831. In title, 742. Time of, 655, 711, 742.
- ‘Azab (Merpaba). Vessels, 402, 402, 403, 440. Sealings, 443. Time of, 442, 443.
- Bocchoris (Wahkarē^c). Graffito, 789. Time of, 789, 789, 789.
- Cambyses (Mesutirē^c). Time of, 799, 799.
- Cleopatra VII Philopator. Time of, 743, 744, 744 744.
- Darius I. Measuring vessel, 842. Sistrum, 863. Time of, 799, 800, 800, 800, 801, 801, 801, 815, 844, 867, 867.
- Den (Khasty). Vessels, 402, 402, 436, 441, 442, 447. Sickle, 441. Sealings, 436, 441, 441, 442, 442, 443, 445, 446, 447, 499. Time of, 440, 442, 443, 446, 447.
- Haremḥab (Zeserkheperurē^c). Statues, 852, 852. Stelae, 832, 870. In scenes, 828 (on stela), 846. Blocks, 763, 845, 850. Vessel, 773. Time of, 554, 661, 701, 706, 773, 781, 861.
- Hatshepsut (Ma^ctkarē^c). Jar-fragment, 845.
- Hetep, *see* Hetepsekhemui.
- Hetepsekhemui (Hetep). Vessels, 403, 403, 403. Sealings, 613. Name on statue, 864.
- Hor, *see* Awibrē^c I.
- Ibi (Ḳakarē^c). Pyramid, 425.
- Irynūter, *see* Semerkhet.
- Isesi (Zadkarē^c). Pyramid-complex, 424. Pyramid, in titles, *see* Appendix G. Blocks, 421. Sealing, 542. Stopper, 598. Ink slab, 899. Copy of letter, in tomb, 496. Mentioned on false-door, 674. Time of, 452, 455, 485, 489, 494, 595, 596, 599, 600, 693, 697. Wives, Meres^cankh (probably); name unknown, 424; son, Rē^cemka (probably); *see* Index 2.
- Ḳa^ca. Vessels, 402, 402, 402, 403. Label, 445. Sealings, 443, 443, 444, 445, 446, 447. Time of, 443, 443, 444, 446.
- Ḳakai, *see* Neferirkarē^c.
- Ḳakarē^c, *see* Ibi.
- Ḳashta (Ma^ctrē^c). Plaque, 831.
- Kha^cba. Bowl, 898.
- Kha^csekhem. Vessel, 402.
- Kha^csekhemui (Nebwyhetepimef). Vessel, 403. Sealings, 402, 415.
- Khasty, *see* Den.

- Khebebesb (Senenenptah-seteptatenen). Time of, 804.
- Khenzer (Userkarē). Pyramid-enclosure, 434. Statue, 435. Brick with date, 434. Graffiti, 434. Wife, Seneb[ḥenaʿs] (possibly); *see* Index 2.
- Khephren. Statue, 842. Sealing, 598. In titles, *see* Appendix G and 803.
- Khetu (unspecified). Man called after, 687.
- Khufu. Mentioned on statue, 878. Time of, 502. In titles, *see* Appendix G and 803. Son, Kawaʿb; *see* Index 2.
- Menes. In title, 812.
- Menkauhor (Ikauhor). Statue, 842. In scenes, 750, 820, 820. Time of, 455, 485, 582, 611, 641. In titles, *see* Appendix G.
- Menkaurē. Statue, 842. In scene, 750. In titles, *see* Appendix G.
- Merenrē I (Nemtiemsaf). Pyramid-complex, 425. Pyramid mentioned, 431. Vessels, 430, 626. Time of, 609, 673, 673, 674, 753. In titles, *see* Appendix G. Wife (?), Neit; *see* Index 2.
- Merenrē II (Nemtiemsaf). *See* Nemtiemsaf, Index 2.
- Merneptah (Baenrē-meriamūn). Temple, 854; pylon, 855. Palace, 856. Temple, mentioned on stela, 858; in titles, 737, 802. Statues, 837, 857. Sphinxes, 779, 836. Stela, 843. Doorway, 832. Blocks, 861, 872. In scenes, 833, 861. Cartouches on statue, 857. Time of, 715, 737. *See also* Merneptah, Index 2.
- Merneptah-Siptah (Akhenrē-setepenrē). Blocks, 850, 872. Column-fragment, 872. Time of, 851.
- Merpaba, *see* ʿAzab.
- Merykarē. In titles, *see* Appendix G.
- Meryrē, *see* Pepy I.
- Merytneit. Vessels, 445. Time of, 444.
- Naʿr, *see* Naʿrmer.
- Naʿrmer (Naʿr). Vessel, 402.
- Nebka. In title, *see* Appendix G. *See also* Sanakht.
- Nebkhepshehrē, *see* Apophis III.
- Necho II (Wehemēbrē). Altar, 841. Vase, 820. Time of, 413, 588, 740, 797, 797, 849.
- Neferirkarē (Kakai). Offering-table, 898. Sealings, 880. Mentioned in text, 456. Estates mentioned, 873. Time of, 456, 466, 478, 577, 582, 583, 697, 699, 747, 760. In titles, *see* Appendix G.
- Neferkarē (Dyn. VII or VIII). Mother, ʿAnkhespepy, *see* Index 2.
- Neferkarē, *see* Pepy II.
- Nektanebos I (Nekhtnebef). Pylon, 780. Avenue of sphinxes, 778. Donation-stela, 780. Blocks, 671, 779, 851. Graffiti, 591. Time of, 831, 874. In title, 503.
- Nektanebos II (Nekhtnarhebi). Temples, 778, 821. Sphinxes, 778. Shrine, 825. Blocks, 851. Foundation deposit, 507. Sistrum handle, 826. In scene on stela, 779. Time of, 503, 504.
- In titles, 743, 747, 812, 812, 813. Father, Thaiḥepimu; *see* Index 2.
- Nemtiemsaf, *see* Merenrē I and II.
- Nepheritis I (Baenrē-merineteru). Time of, 804, 804.
- Neterikhet (Zoser). Step Pyramid enclosure, 399. Pyramid mentioned in Ramesside graffito, 434. Statues, 407, 414. Boundary stelae, 407, 414, 416. Box, 401. Sealings, 401, 402, 415, 437, 439, 448. In Ramesside scene, 556. Name(s) on stela, 790; on statue-base, 825. Time of, 437.
- Neuserre (Iny). Statue, 842. Lintel and jambs, 835. Sealing, 565. Time of, 453, 463, 464, 467, 468, 481, 584, 593, 641, 689, 696, 722, 764. In titles, *see* Appendix G.
- Ninüter. Vessels, 403, 403. Sealings, 436, 437, 440, 613. Name on statue, 864. Time of, 436, 437, 440.
- Nubnūfer (probably same as Raʿneb). Vessels, 403.
- Osorkon I (Sekhemkheperrē-setepenrē). In scene, 854.
- Osorkon II (Usermaʿetrē-setepenamūn). Mentioned in text, 839. Time of, 785, 846. Sons, Nemareth, Sheshonk; *see* Index 2.
- Osorkon III (Usermaʿetrē-setepenamūn). Plaque, 831.
- Pemu (Usermaʿetrē-setepenamūn). In scene on stela, 786. Time of, 786, 847, 847.
- Pepy I (Nefersahor, later Meryrē). Pyramid-complex, 422. Blocks, 828, 872. Vessels, 422, 430, 431, 537, 626, 677. Cylinder seal, 542. Plaque, 395. Decree, 876. Man called after, 687. Mentioned in text, 520. Pyramid mentioned, 431, 508. Names on sarcophagus of Queen ʿAnkhespepy, 676. Time of, 463, 508, 508, 520, 536, 570, 586, 609, 619, 621, 625, 753, 756. In titles, *see* Appendix G. Mother, Iput I; daughter, Neit; *see* Index 2.
- Pepy II (Neferkarē). Pyramid-complex, 425. Statues, 429, 827. Vessels, 430, 430, 626, 681. Plaque, 395. Disks, 432. In scenes, 395 (plaque), 685 (panel), 750 (Ramesside block). Decrees, 433, 684. Dedication on lintel, 432. Graffito, 428. Pyramid mentioned, 431, 432, 432; on vase, 433. Man called after, 687. Time of, 432, 609, 610, 678, 683, 683, 684, 684, 684, 685, 685, 685, 686, 686, 686, 687, 742. In titles, *see* Appendix G. Wives, ʿAnkhespepy, Iput II, Neit, Wezebtan; *see* Index 2.
- Pepy (unspecified). In titles, 798.
- Peribsen. In title, *see* Appendix G.
- Petubastis I (Usermaʿetrē-setepenamūn). In scene on stela, 858.
- Petubastis (Seḥetepibrē). Statue, 852.
- Psammetikhos I (Wehebrē). Canopic-jar, 826. Foundation deposit, 829. Cartouches in tomb, 589. In title, 765. Time of, 588, 669, 740, 746, 791, 797, 797, 811, 838, 861, 866.

- Psammetikhos II (Neferebrē). In scene on stela, 826. Block, 763. Bronze corner of door, 830. Plaque, 831. *Menat*-fragment, 875. Time of, 772, 831, 838, 848, 861, 866.
- Psammetikhos III (ʿAnkhkaenrē). *See* Psammethek, Index 2.
- Psusennes I (ʿAkheperrē-setepenamūn). Cartouches on lintel, 845.
- Ptolemy I Soter. Block, 874. Daughters, Arsinoë [II], Philotera; *see* Index 2.
- Ptolemy II Philadelphus. Blocks, 777, 824. In title, 741. Time of, 743, 743, 743, 748. Graffiti, 796.
- Ptolemy III Euergetes I. In titles, 718, 741, 747. Time of, 743, 748.
- Ptolemy IV Philopator. In scene, 862 (stela with decree). In titles, 718, 741, 747. Time of, 743, 748, 812.
- Ptolemy V Epiphanes. In scene, 777. Cornice block, 777. In titles, 718, 741. Time of, 718, 804, 812, 812.
- Ptolemy VI Philometor. In scene on stela, 862. Time of, 804, 804.
- Ptolemy VIII Euergetes II. Time of, 738, 744, 804, 804.
- Ptolemy IX Soter II. Time of, 738.
- Ptolemy X Alexander I. Time of, 738.
- Ptolemy XII Neos Dionysos. Statue, 864. Time of, 738.
- Ptolemy XV Caesar. Time of, 827.
- Ptolemy (unspecified). In scene on stela, 828. Time of, 804.
- Raʿkhaʿef, *see* Khephren.
- Raʿmesse-meriamūn, *see* Ramesses II.
- Ramesses II (Usermaʿetrē-setepenrē Raʿmesse-meriamūn). Temples, 831, 843, 845, 852. Temples in titles, 654, 667, 713, 726, 748, 775, 803, 845. Statues, 817, 821, 832, 832, 835, 835, 836, 836, 837, 840, 846, 863, 863, 863, 863. Statues of Ptaḥ dedicated by, 833, 868. Sphinxes, 835, 836, 841. Apis canopic-jar, 819. Vase, 559. Pectoral, 782. Foundation deposits, 832, 832, 832. Columns and fragments, 760, 845, 856, 872, 872, 872. False-door, 833. Altar-pedestal, 839. Cartouche(s) adored, 654, 860. Cartouches on statues, 823, 838; on table, 841. Blocks, jambs, etc., 779, 824, 827, 833, 835, 850, 854, 854, 861, 872, 872. Name written by Ptaḥ, 872. Name on shrine of Ptaḥ, 874. In scenes, 654, 669, 782, 832, 839, 850, 850, 850, 850, 860, 860, 862, 872, 874; *see also* temples. Graffiti, 408, 412, 412, 428, 434. Time of, 553, 559, 654, 665, 666, 667, 667, 667, 704, 706, 708, 713, 715, 726, 728, 740, 742, 748, 750, 756, 770, 771, 771, 775, 782, 783, 784, 785, 818, 821, 824, 838, 838, 838, 838, 844, 847, 865, 865, 868. Mother, Tui; sons, Khaʿemwēset, Merneptah, Raʿmeses-userpeḥti; daughters, Bentʿanta, Merytamūn; *see* Index 2.
- Ramesses III (Usermaʿetrē-meriamūn). Statues, 837, 864. Stela, 858. Altar-pedestal, 839. Column-fragments, 850. Pillar, 873. Doorway, 832. Lintel, 829. Jamb, 858. Block, 861. Plaque, 875. In scenes, 858 (stela), 860 (lintel). Cartouche on statue, 860. Statues mentioned on stela, 858. Time of, 851, 861.
- Ramesses IV (Heḫmaʿetrē-setepenamūn). Statues, 837, 840, 864. Doorway, 855, 855. Time of, 707.
- Ramesses VI (Nebmaʿetrē-meriamūn). Statues, 837, 837, 864, 864. Cornice, 850. Shrine-fragment, 824. Jar, 785. Cartouches adored, 860. Time of, 785.
- Ramesses VII (Usermaʿetrē-meriamūn). Altar-pedestal, 839.
- Ramesses IX (Neferkarē-setepenrē). Altar-pedestal, 839. Vessels, 785, 820. *Zad*-amulet, 785. In scenes, 858 (stela), 861. Time of, 785, 859.
- Ramesses XI (Menmaʿetrē-setepenptah). Block, 861. Furniture-fragment, 824.
- Ramesses (unspecified). In title, 812.
- Ramesses-Siptah. Vessels, 785, 785.
- Raʿneb. Stela, 870. Vessel, 403. Sealings, 613. Name on statue, 864. *See also* Nubnūfer.
- Raʿneferef. Cylinder seal, 598. Sealing, 598. Time of, 581, 585, 698. In titles, *see* Appendix G.
- Raʿzedef. In scene on Ramesside block, 750. In title, 803; *see also* Appendix G.
- Sabacon (Neferkarē). Chapel, 842. Stela, 789. Block, 843. Time of, 789, 873.
- Sahurē. Mentioned in text, 482. Cartouches on late stela, 815. Time of, 450, 482, 577, 580, 582, 722, 744, 878, 894. In titles, 803, 812, 873; *see also* Appendix G.
- Sanakht. Sealings, 405. *See also* Nebka.
- Sekhemib Perenmaʿet. Vessels, 403.
- Sekhemkhaʿu, *see* Shepseskare.
- Sekhemkhet. Step pyramid enclosure, 415. Sealing, 416. *See also* Teti.
- Semerket (Irynūter). Vessels, 402, 402, 402, 442. Senti, *see* Den.
- Send. In titles, *see* Appendix G.
- Senkamaniskeñ. Faience fragment, 875.
- Sesonchis I (Hezkheperrē-setepenrē). Cornice-fragment, 851. Column-base, 873. Time of, 760, 823, 841, 841, 842, 866, 872.
- Sesonchis III (Usermaʿetrē-setepenamūn). In scene, 873. Time of, 786, 786, 786, 847.
- Sesonchis V (ʿAkheperrē). Statue, 821. In scenes on stelae, 788, 788, 788. Time of, 787, 787, 787, 848.
- Sesostris I (Kheperkarē). Statues, 863, 863. Statue in scene on stela, 885. Mentioned in text, 564. Time of, 394, 832.
- Sesostris II (Khaʿkheperrē). Statues, 847, 863. Pectoral, 883. Mentioned on statue-base, 879. Daughter, Sit-ḥathor; *see* Index 2.
- Sesostris III (Khaʿkaurē). Pyramid-complex, 882. Fragment with names, 885. Pectoral, 884. Time of, 725, 896, 896, 897, 897, 899. Wives, Khnemt-neferḥezet, Nefert-ḥenut; daughters, Ment, Mereret (Meryt), Sent-senbetes; *see* Index 2.

- Sesostris (unspecified). Cartouche on block, 571.
- Sethos I (Menma'etrē). Chapel, 843. Statues, 843, 863, 863. Lintel, 860. Block, 861. Vessel, 874. Weight, 829. In scenes, 664 (stela), 846. Temple, mentioned on plaque, 875. Temple, in title, 773. In title, 716. Time of, 559, 664, 716, 771, 773, 782, 821, 838.
- Sethos II (Userkheperurē-setepenrē). Statues, 863, 864. Shrine-fragment, 824. Column-fragments, 833, 872. Blocks, 850, 872. Names of, in temple, 844. Time of, 704, 845, 866.
- Setnakht (Userkha'urē-setepenamūn). Block, 861. Cartouches on pylon, 832. Names adored, 861.
- Shabataka (Zadkaurē). Statue, 837. Block, 839.
- Shepseskaf. Burial-complex, 433. In title, 688; *see also* Appendix G.
- Shepseskare (Sekhemkha). Cylinder seal, 875.
- Siamūn (Neterkheperre-setepenamūn). Building of, 853. In scenes on lintels, 853, 853. Names on lintels, 853, 858. Cartouches on column, 850.
- Sneferka. Vessels, 403, 446.
- Snefru. Pyramid-complexes, 876. Stelae, 877. Cylinder seal, 880. Names in mason's graffiti, 881. Mentioned on false-door, 674; on statues, 878, 899. Man called after, 687. Time of, 502. In titles, 743, 765, 878, 879, 879, 879, 879; *see also* Appendix G. Son, 'Aḥauka; *see* Index 2.
- Taharqa (Khunefertemrē). Block, 843. Weight, 875. Time of, 791, 792.
- Takelothis II (Hezkheperre-setepenrē). Name on fan, 652. Cartouches on block (stela), 785. Time of, 785, 786.
- Teos (Irma'etenrē). Bowl fragment, 831. Brother, Thaihepimu; *see* Index 2.
- Teti. Pyramid-complex, 393. Statues, 562, 827. Lintel, 835. Vessels, 394. Mace-heads, 395. Model sistrum, 829. Death-mask, 395. Later stelae, mostly with scenes, 395, 395, 395, 395, 572, 572, 667, 781, 823. Mentioned on blocks, 397, 422, 607. Pyramid mentioned in Rameside graffito, 434. Time of, 460, 460, 521, 525, 646, 755. In titles, 394, 550, 551, 700, 812; *see also* Appendix G. Wives, Iput I, Khuit; daughter, Inti; *see* Index 2. *See also* Teti-merneptah.
- Teti (probably Sekhemkhet). In scene on Rameside block, 556.
- Teti-merneptah (i.e. Teti). In scenes on naos-shaped statue-pedestal, 729.
- Tutankhamūn (Nebkheperurē). Statue, 852. In scenes, 659, 846; on stela, 870. Glass pendants, 781. Graffito, 414. Time of, 655, 661, 704, 711, 781, 870.
- Tuthmosis I ('Akheperkarē). In scene on stela, 833. Temple, in title, 740.
- Tuthmosis III (Menkheperre). In scene on stela, 859. Vessels, 829, 829. Cylinder seal, 830. Plaque, 831. Temple, in title, 701. Time of, 773, 774, 837, 865, 865.
- Tuthmosis IV (Menkheperurē). Temple, 842. In scenes on stelae, 849, 871. Offering table, 830. Time of, 721, 730, 833, 865.
- Unis. Pyramid-complex, 417. Statue (?), 625. Vessels, 421, 430. 'Crews' of, in scenes, 419. Mentioned on statue, 651; on stela, 652. Time of, 599, 600, 616, 624, 631. Pyramid, in titles, 615, 615; *see also* Appendix G. Wives, Khenut, Nebt; daughter, Hemtrē (Hemi); *see* Index 2.
- Userkaf. Pyramid-complex, 397. Statue, 397. Cylinder seal, 775. Cartouche on offering-basin, 437. In scene on Rameside block, 556. Time of, 437, 581, 746, 762. In titles, *see* Appendix G. Mother, Neferhetpes; daughter, Kha'ma'et; *see* Index 2.
- Userkarē, *see* Khenzer.
- Wedemu, *see* Den.
- Weneg. Vessels, 403, 440.
- Xerxes I. Time of, 734.
- Zadkarē, *see* Isesi.
- Zer. Vessels, 402. Labels, 436, 436, 441. Sealings, 437, 444, 444, 446. Time of, 436, 437, 444.
- Zet. Vessel, 402. Wand, 445. Labels, 445. Sealings, 445. Time of, 445.
- Zoser, *see* Neterikhet.
- Name? Vessel, 403.

2. PRIVATE NAMES

SECTION I

References to tomb-owners in Roman type.

HPM = High Priest of Memphis.

References to Addenda not included

1. Ababsunüter-nekhtef, 860.
 2. Abeb, 768.
 3. Abebi, 546.
 4. 'Abed, 552.
 5. Abeh, 734.
 6. Abneb, 741.
 7. Afti, f. 790.
 7. 'Aha, 405.
 7A. 'Aha-^{ca}, 572.
 8. 'Aḥaka, 404.
 9. 'Aḥauka (various), 722, 878.
 10. 'Aḥemnefert, f. 449.
 11. 'Aḥmosi (various), 413, 507, 721, 736, 742, 771, 798, 799, 800, 801, 811, 811, 812, 813, 815, 819, 833, 844.
 'Aḥmosi, f. (various), 732, 742.
 'Aḥmosi, *see* 'Aḥmosi-sineit.
 12. 'Aḥmosi-men (Ir^aḥeka), 801, 801, 803.
 13. 'Aḥmosi-mer(y)ptah, 801.
 14. 'Aḥmosi-sineit ('Aḥmosi), 831, 867.
 15. 'Aḥmosi . . . , 810.
 16. Ak, 722.
 17. 'Akheperre^c (?), 790.
 18. Akhetbu, f. 734.
 19. Akhi (Ip), 690.
 20. Akhi, 677.
 Akhi, *see* Unis-akhi.
 21. 'Akhet, 558.
 22. Akhti^a, 500.
 23. Akhtihotp (Hemi), Vizier, 627, 629.
 24. Akhtihotp (Ipi), 609.
 25. Akhtihotp (Ipi-uzau), 606.
 26. Akhtihotp, Vizier, 597, 599, 600, 605.
 Akhtihotp (others), 453, 480, 602, 633, 634, 638, 721, 757, 759.
 Akhu, *see* Methefi.
 27. 'Aksonb, 848.
 28. 'Aku, f. 571.
 29. Amenardais [I], daughter of Kashta, 831.
 30. Amenardais (various), 651, 793, 794, 795, 796, 809, 860.
 Amenardais, f. 734.
 31. Amenemḥab (Pakharu), 740.
 32. Amenemḥab (others), 428, 552, 571, 655, 669, 736, 740, 783.
 33. Amenemḥēt (various), 412, 572, 735, 845.
 34. Amenemḥēt^aankh, probably son of Amenemḥēt II, 394, 886, 896, 898.
 Amenemḥēt^aankh, 898.
 35. Amen(em)ḥēt-pamesha^c, 790.
 36. Amenemōnet, 552, 820.
 Amenemōnet (others), 701, 861, 874.
 37. Amenemōpet, 773, 861.
 Amenemōpet (others), 671, 785, 859, 870.
 Amenemōpet, f. (various), 572, 748-9.
 38. Amen(em)ōpet, 831.
 39. Amen(em)ōpetemḥēt, 866.
 40. Amenemsaf, 801.
 41. Amenemwia (various), 556, 763.
 42. Amenḥori . . . , 749.
 43. Amenhotp (Huy), 571, 702-3, 704, 831, 835, 836, 848, 849.
 Amenhotp (Huy), 770, 785, 844, 847, 847.
 Amenhotp (Huy), 874.
 44. Amenhotp (others), 572, 755, 762, 802, 810, 818, 859, 886.
 45. Amen^aaseb (?), 809.
 46. Amenir(t)erau (?), 740.
 47. Ameniy (Bentehtuf), 763.
 48. Amenkha^c, 795.
 49. Amenma, 557.
 50. Amenmes(su), 838.
 51. Amenmosi (Ra^amosi), 675.
 Amenmosi (Ra^amosi), 773.
 52. Amenmosi, 770, 771.
 Amenmosi (others), 571, 688, 701, 717, 737, 783, 834.
 53. Amennakht, 763.
 54. Amennezem, 794.
 55. Amentanakhti, 573.
 56. Amentefnakht (Ḥa^aḥebrē^c-meryptah), 650.
 57. Amentefnakht, 827.
 Amentefnakht, *see* Weḥ-ebrē^c.
 58. Amenwahsu, 729.
 59. Ameny, Vizier, 832.
 Ameny (others), 429, 433, 687, 688.
 60. Ameny-snefru, 878.
 61. Ameny-wah, 878.
 62. Ameny-wahib, 674.
 63. 'Amet, f. (various), 847, 885.
 64. 'Anemḥo (Pasekhem), 738.
 65. 'Anemḥo, 718, 747, 748.
 'Anemḥo, 814.
 66. 'Ankh, 759.
 67. 'Ankhef (various), 510, 516.
 68. 'Ankhefenkhons, 788.
 69. 'Ankhefenmut, 853.
 70. 'Ankhef(en)mut, 811.
 71. 'Ankhefensekhmet, 760, 841, 866, 872.
 'Ankhefensekhmet (others), 613, 718, 802, 802, 848, 860.
 72. 'Ankhefensekhmet (?), 809.
 73. 'Ankhefenubaste, 787.
 74. 'Ankhemmatet, 773.
 75. 'Ankhemthenent (various), 795, 866.
 76. 'Ankhes, f. 802.
 77. 'Ankhesni, f. 741.
 78. 'Ankhet, f. 612.
 79. 'Ankh-ḥap, 743, 765.
 'Ankh-ḥap (others), 504, 505, 507, 592, 612, 763, 765, 810, 813, 813, 814, 814, 862.
 'Ankh-ḥap, *see* Pashenptah.
 80. 'Ankh-ḥapi, 651.
 81. 'Ankh-ḥarmenḥap, 827.
 82. 'Ankh-has, f. 465.
 83. 'Ankh-ḥathor, f. 746.
 84. 'Ankh-ḥor (Weḥebrē^c), 815.
 85. 'Ankh-ḥor (others), 588, 732, 763, 789, 790, 795, 805, 807, 807.
 'Ankh-ḥor, *see* Duarē^c.
 86. 'Ankhi (Inthi), 608.
 87. 'Ankhi (Ithi), 611.
 88. 'Ankhi (various), 451, 610, 622.
 89. 'Ankhiris (various), 452, 488.
 'Ankhiris, *see* Iteti.
 90. 'Ankhirptah (various), 641, 722.
 91. 'Ankh-irterau, f. 803.
 92. 'Ankhka, 441, 442, 442, 446.
 93. 'Ankhkaus, f. 462.
 94. 'Ankh-kakai (various), 458, 753, 762.

95. 'Ankh-khons (various), 788, 791, 792, 805, 810, 822, 862.
96. 'Ankhma', 465.
97. 'Ankhma'hor (Sesi), 512.
98. 'Ankhma'ka (various), 481, 760.
99. 'Ankhma'nemti, 735.
100. 'Ankhma'rē', 455.
'Ankhma'rē', 696, 697.
'Ankhma'rē', 894, 894.
101. 'Ankh-meryrē', 768.
102. 'Ankhnebef (various), 672, 679.
103. 'Ankhnebtyseserty, 416.
104. 'Ankhnesmeryrē', f. 431.
105. 'Ankhnespepy, f. (various), 672, 675, 676, 681, 751.
106. 'Ankhpefheri (various), 573, 794, 809, 813, 822.
107. 'Ankhpekhhod (various), 649, 790, 790, 809, 824, 824, 827, 849.
108. 'Ankh-psammethēk (various), 770, 800, 867.
109. 'Ankh-ptah (various), 712, 860.
110. 'Ankhsemtu, 788.
111. 'Ankh-sheshonk, 790, 794.
'Ankh-sheshonk (others), 789, 807, 866, 866, 866.
112. 'Ankh-sineb'ankh, 822.
113. 'Ankhtef, 544.
114. 'Ankh-tes-heret, f. 811.
115. 'Ankh-thekerti, 792, 793.
116. 'Ankh-(the)kerti, 814.
117. 'Ankhu, 571, 847.
118. 'Ankh-unnūfer (various), 789, 791, 792, 798, 802, 802, 805, 813, 816.
119. 'Ankh-wehebrē' (various), 798, 861.
120. 'Ankhwezes, 739.
121. 'Ankhzefes, f. 439.
122. 'Ankh... (various), 547, 763.
123. Antef (various), 428, 682, 686.
124. 'Anu, 685.
125. 'Aperēf (various), 532, 768.
126. Aperenyas-pakhem (Pehernūfer-pakhem), 764.
127. 'Aperir, 562.
Apollonius junior, *see* Aperenyas-pakhem.
128. 'Arptaḥ-ḥap (various), 794, 818.
'Arptaḥ-ḥap, *prob.* f. 772.
129. Arsinoë [II], f. 743.
Arsinoë, *see* Irsentay.
130. 'Ashakhet, 845.
131. 'Ash'ash, 810.
132. 'Ashau, 547.
133. 'Ash-herēf, 547.
134. 'Ashōkhi, 805.
135. Atemardais, 798.
Atemardais, f. 588.
136. Atemḥotp, 792.
137. 'Ath, 813.
138. 'Athma (?), 722.
139. 'Ati, f. 736.
- Baḥi (?), *see* Rebaḥi.
140. Baiyti, f. 507, 507.
141. Bakert, 726.
142. Bakt, f. 572.
Bakt, *see* Beketamūn.
143. Basa, 815.
144. Bau, 676.
145. Bebi (various), 629, 633.
Bebi, f. 451.
Bebi, *see* Maru.
Bebi, *see* Nubḥotp.
Bebi, *see* Setibti.
Bebib, *see* Senezemib.
Bebibi, *see* Senezemib.
146. Bebu, 571.
147. Bek'ankhet, f. 759.
148. Bekenamūn (various), 857, 861, 869.
149. Bek(en)ihet, 592.
150. Bekenkhons, 822.
151. Bekenmin, 744.
152. Bekennanefu (Psammethēk-menkhīb), 822.
153. Bekenptaḥ (various), 789, 822.
154. Beken[rē', 833.
155. Bekenrenēf (various), 588, 763, 790, 793, 808, 809.
156. Beketamūn (Bakt), f. 706.
157. Beketenēsi (?), f. 771.
Benithen, *see* Ra'emeses-emperrē'.
158. Bensi, 738.
159. Bent'anta, f. 840.
Bentehtuf, *see* Ameniy.
160. Benuiu, 732.
161. Bepeshes, 869.
Berenice, *see* Berentaget.
162. Berentaget (*i.e.* Berenice), f. 743.
163. Beti, f. 734.
164. Bezmosi, 728.
165. Bia (Irety), 623.
166. Bintenduanūter, 828.
167. Biti, f. 674.
168. Biu, 677, 677.
Biu, *see* Kha'bauknum.
169. Buiruteha, 795.
- 169a. Buy, f. 675.
170. Cleopatra II, 804.
171. Dedet, f. 745.
172. Degem (Merypepy), 679.
173. Degenneit (?), f. 669.
174. Demez, 469, 470, 471, 478.
Demez, f. 729.
175. Denes (?), 436.
176. Depet, f. 701.
177. Dersenez (Neferkarē'-ankh), 678.
178. Deryn (?) (various), 738, 738.
179. Deshri, 673.
180. Desi, 520.
181. Desnub, f. 649.
182. Deubasteiau, 822.
183. Dḥout (various), 573, 790.
184. Dḥout-enmekhat, 651.
185. Dḥutardais (various), 791, 811.
Dḥutardais, f. 763.
186. Dḥutemḥab, 783.
187. Dḥuti-herib, 812.
188. Dḥutiptah, 813.
189. Dḥutmosi (Ra'mosi), 783.
190. Dḥutmosi, 780, 781, 851.
Dḥutmosi (others), 395, 712, 742, 749.
191. Di-iaut, 731.
192. Diptahiau (various), 789, 792, 802, 802, 802, 811, 811, 813, 817.
193. Duāenrē', 608.
194. Duāḥap, 595.
195. Duārē' ('Ankh-ḥor), 813.
196. Duārē', 878, 894.
Duārē', 761.
Duārē', *see* Ity.
197. Duatnub, f. 690.
198. Duauḥotp, f. 539.
199. Dwensupanūfer, 810.
200. Emnūfer, 734.
201. Esamūn (various), 792, 792.
202. Esbanebbed, 800, 802.
Esbanebbed (others), 648, 802, 814.
203. Esbi, 824.
204. Esby, 824.
205. Esdḥout, 669.
206. Eshāremwia, 826.
207. Es-ḥatmeḥit, 720.
208. Eshor (various), 767, 824.
209. Eshu, 794.
210. Ēsi (various), f. 715, 745.
211. Ēsiardais, f. (various), 505, 613, 817.
212. Ēsiarḥesbet, f. 612.
213. Ēsiemḥēti, f. 810.
214. Ēsiemkhebi, f. (various), 503, 771, 771, 772, 796.
215. Ēsinefert, f. (various), 704, 737, 871.
216. Ēsinḥertardais, f. 831.
217. Ēsireshti, f. (various), 651, 763, 795, 803, 803, 814, 814.
218. Esisut (Pedubaste), 743, 743, 747.

219. Esisut (others), 505, 743.
 220. Ēsiwert, f. (various), 731, 811, 813, 868.
 221. Eskhons, 746.
 222. Esmerptah, f. 866.
 223. Esmihos, 867.
 224. Esnebttau, f. 798.
 225. Esnuwēr, 812.
 226. Espakhutau, 802.
 227. Espaper-webekhet, 795.
 228. Espekafai'a, 809.
 229. Esptah, 786, 872.
 Esptah (others), 792, 792, 809, 812.
 Esptah, *see* Ptaḥemma-kheru.
 230. Esshu-tefnut, 507.
 231. Estaneb . . ., 788.
 232. Estanefert, f. 799.
 233. Estary(t)enhor, 734.
 234. Esunnüfer, 799, 814.
 Esunnüfer (others), 802, 805, 806.
 235. Es-zad, 816.
 236. Faihezui, 878.
 236A. Fefi, 741.
 Fefi, *see* Ifefi.
 Fefi, *see* Ni'ankh-snefru.
 237. Gegi, 691.
 238. Gemḥap (various), 503, 612.
 239. Gemnefḥarbak (various), 740, 788, 796, 796.
 240. Gemni (Megui), 544.
 241. Gemni (others), 517, 522, 544, 544, 545, 545, 546, 547.
 Gemni, *see* Gemniemḥet.
 Gemni, *see* Kagemni.
 242. Gem(ni)'ankh, 544.
 243. Gemni'ankhu (various), 544, 547.
 244. Gemniemḥet (Gemni), 538.
 245. Gemniemsaf (various), 545, 547.
 246. Gemniḥarbak, 813.
 247. Gemniḥotp, 547.
 248. Gemni-iu, 544.
 249. Gemni-iy (various), 544, 570.
 250. Gemni-theses, 547.
 251. Gemniuser, 517.
 252. Gegerem, 708.
 Ha'a'embrē-meryptah, *see* Amentefnakht.
 253. Hadnakht, 412.
 254. Hager (various), 749, 817.
 Hager, f. 652.
 Haishtef, *see* Unis-ḥaishtef.
 255. Haishtef-wēr, 615.
 256. Ḥapī, 505.
 257. Ḥarardais, 824.
 258. Ḥar-ashakhet, 868.
 259. Ḥarbes (various), 770, 771, 789, 813, 815, 831.
 260. Ḥardedef, 802.
 261. Ḥaremakhet, 718, 749.
 Ḥaremakhet (others), 770, 772, 801, 814.
 262. Ḥaremḥab, future King, 655, 865.
 Ḥaremḥab (others), 507 (*as* Harkhebi *in error*), 652, 667, 764, 813, 819, 822.
 263. Ḥaremḥet, 648.
 264. Ḥaremḥa'et, 812.
 265. Ḥaremḥa'kheru (various), 801, 810.
 266. Ḥarem . . . ḥotp, 802.
 267. Ḥarenḥap (various), 792, 794, 839, 867.
 268. Ḥarḥap (various), 794, 808.
 Ḥarḥap, f. 868.
 269. Ḥarḥatbehes, 767.
 270. Ḥarḥotp, 677.
 271. Ḥar-imḥōtep (various), 743, 765.
 272. Ḥarkhebi (various), 507 (*correct to* Ḥaremḥab), 588, 772, 792, 798, 799, 800, 813, 817.
 Ḥarkhebi, *see* Pedēsi.
 273. Ḥarkhet (?), 651.
 274. Ḥarkhons (various), 749, 798.
 275. Ḥarma'kheru (various), 806, 813.
 276. Ḥarmin, 664.
 277. Ḥarmosi, 669.
 Ḥarmosi, 792, 817.
 278. Ḥarnakht (various), 809, 810, 824.
 279. Ḥarneziofef, 796.
 280. Ḥarpaēsi, 822.
 281. Ḥarsemtuemḥet, 839.
 282. Ḥarshefḥotp (various), 516, 567.
 283. Ḥarshefnakht (various), 544, 544, 544, 545, 547, 560, 562, 569, 569, 798.
 284. Ḥarshef-shema . . ., 679.
 285. Ḥarsiēsi, 786, 847, 848.
 Ḥarsiēsi (others), 649, 789, 791, 792, 794, 794, 795, 799, 800, 801, 805, 807, 809, 813, 813, 813, 815, 816, 824, 824.
 286. Ḥartesnakht, f. 899.
 287. [Ḥa]r[ua], 838.
 288. Ḥarwen, 787.
 289. Ḥarwēr, 496.
 290. Ḥarwoz, 805, 806.
 [Ḥarwoz (others), 573, 652, 766, 770, 788, 790, 792, 800, 803, 803, 805, 807, 809, 810, 810, 810, 810, 812, 813, 824, 838.
 291. Ḥarwoz-paheka, 805.
 292. Ḥathoremakhet, f. 862.
 293. Ḥathoremḥet, f. (various), 718, 790.
 294. Ḥathor-hotpet, f. 888.
 295. Ḥathoriyti, f. 879.
 296. Ḥathornüfer, f. 490.
 297. Ḥathorshespes, f. 451.
 298. Ḥatiay (Kha'emwaset), 853, 854.
 299. Ḥatiay (others), 669, 745, 775.
 300. Ḥatkau, 547.
 301. Ḥatkaus, f. 678.
 302. Ḥatneferu, 806.
 303. Ḥatnüfer, 860.
 304. Ḥaubaste (?), f. 573.
 Ḥeba, *see* Seshemnüfer.
 305. Ḥebai, 678.
 306. Ḥeby, 702.
 307. Ḥebyt, f. 566.
 308. Ḥeka (various), 792, 793.
 309. Ḥekaemḥet, 809.
 310. Ḥekaemsaf, 799, 801.
 Ḥekaemsaf (others), 650, 813.
 311. Hekaen . . ., 807.
 Ḥekaib, *see* Meryrē-ankh.
 312. Hekaiofef, 802.
 313. Hekenut, f. 612.
 314. Hekma'etrē-neḥeḥ, 558.
 315. Heknu, f. 461.
 316. Heknunebti, f. 496.
 317. Heku, 735.
 318. Hemaka, 440, 446.
 319. Hemakhti, 496.
 320. Hem'ankh (Ḥemi), 432, 686.
 Hemi, *see* Akhtihotp.
 Hemi, *see* Hem'ankh.
 Hemi, *see* Hemtrē.
 321. Hemkhnun, 419.
 322. Hem-min, 483.
 323. Hemnüfer, 405.
 324. Hemptah, 788.
 325. Hemrē, 643.
 326. Hemsobk, 403.
 327. Hemtrē (Ḥemi), f. 606.
 328. Hemtrē, f. (others), 450, 736, 823.
 329. Hemzeser, 405.
 330. Henat (Khemebrē-men), 719.
 331. Henba, 685.
 332. Heneni (various), 545, 547, 672, 681.
 Heneni, *see* Impy.
 333. Henenu, 677.
 334. Heni, 547.
 335. Henu, f. 394.
 336. Henut, f. (various), 570, 675, 677, 688, 734.

337. Henutemakhet, f. 826.
 338. Henuti, f. 544.
 339. Henutnakhtu, f. 726.
 340. Henutnefert, f. 557.
 341. Henutsen, f. (various), 692, 729, 735, 738.
 Henutsen, *see* Mert-min.
 342. Henutwezeb, f. 733.
 343. Henutwezebt, f. 726.
 344. Henutwezebu, f. 729.
 345. Henutyunu, f. (various), 572, 661.
 346. Hep, 569.
 347. Hepa'a, 807.
 348. Hepardais (various), 792, 794, 809, 815.
 349. Heperiu, 802.
 350. Hepet, f. 799.
 351. Hepetka, f. 586, 691.
 352. Hepi (various), 544, 565, 570, 570, 700, 722.
 Hepi, *see* Sebkhotp.
 353. Hepiu (various), 788, 805.
 See also Hepiuiu.
 354. Hepiuiu, 795. *See also* Hepiu.
 355. Hepmen (various), 767, 795, 802, 815, 815.
 356. Hepmeneh, 812.
 357. Hep-nebma'et, 651.
 357A. Hepu, f. 453.
 358. Hepuser, 790.
 Her, *see* Herib.
 359. Her (?), f. 813.
 Heraker, *see* Herakeria.
 360. Herakeria (Her'ankh), f. 738, 738.
 Herakleia, *see* Herakeria.
 361. Her'ankh, f. 718, 748.
 Her'ankh, f. 744, 744, 747.
 Her'ankh, f. (others), 743, 743, 748.
 Her'ankh, *see* Herakeria.
 362. Herba(neb)ded, 557.
 363. Herenhepu, 805.
 364. Hererem, 790.
 365. Heres'ankh, f. (various), 743, 818, 818.
 366. Heresibnes, f. 862.
 367. Herher'ankh, f. 586.
 368. Herib (*perhaps better*: Her) (various), 765, 812.
 369. Heribamun, 798.
 370. Heribek, 788.
 371. Heribes, 790.
 372. Heribesnes, f. (various), 792, 872.
 373. Heribi, f. 831.
 374. Heribni, 823.
 375. Herimeru (Merery), 626.
 376. Herimeru, 539.
 377. Hert, f. 812.
 378. Heru, 738.
 379. Herubaste, 650, 651.
 Herubaste, f. (others), 612, 612, 651, 720.
 380. Hes, 503.
 381. Hesesi, 506.
 382. Hesi (various), 503, 676, 759.
 383. Hest, f. 546.
 384. Hesy, 722.
 385. Hesyrē' (various), 437, 439.
 386. Hēt, 861.
 387. Hetep (various), 451, 544, 550, 633, 690, 858.
 Hetep, *see* Neferkarē'-nakht.
 Hetep, *see* Snefru
 Hetep, f. 549.
 388. Hetep . . . , 547.
 389. Hetepdief, 864.
 390. Hetep-ħathor (Hetep), f. 898.
 391. Hetep-ħathor, f. 875.
 392. Hetepherakhti, 459, 593.
 393. Hetepheres, f. 482, 491.
 Hetepheres, f. (others), 490, 546, 693, 697.
 394. Hetephernebti, f. 407, 414.
 395. Hetephernefert, f. 722.
 396. Hetepi, 562.
 397. Hetepka (Tepka), 447.
 398. Hetepka (others), 542, 542, 745.
 399. Hetepka-khufu, 768.
 400. Hetepmert, f. (various), 562, 563.
 401. Hetepmer-teti, 547.
 402. Hetepmert-teti (Hetep), f. 544.
 403. Hetepmert-teti (others), 562, 567.
 404. Hetepniħap, 796.
 405. Hetep-ptah, 787, 787.
 Hetep-ptah (others), 790, 794, 795.
 406. Hetept, f. (various), 737, 774.
 Hetept, *see* Hetep-ħathor.
 Hetepti, *see* Hetepmert-teti.
 407. Hetepubaste, 746.
 Hetepubaste, f. (various), 649, 803.
 Hethes, *see* Kha'bausokar, 449.
 Hetutu, *see* Minħotp.
 Hezert, *see* Renes'ankh.
 408. Ĥor (Neferebrē'-emakhet or Weħebrē'-emakhet), 587.
 409. Ĥor (others), 565, 573, 651, 673, 738, 787, 792, 793, 794, 796, 800, 802, 803, 803, 804, 805, 808, 813, 813, 861.
 410. Ĥori (Rē'), 726.
 411. Ĥori, 571, 571, 571.
 Ĥori, HPM, son of Kha'emwēset, 703, 871.
 Ĥori, Vizier, 731, 851, 861, 871.
 Ĥori, HPM, father of Vizier Ĥori, 851, 871, 873.
 Ĥori (others), 412, 711, 767, 783.
 412. Ĥory (various), 793, 799, 801.
 413. Ĥui, 794.
 414. Ĥunay, f. 740.
 415. Ĥuti, 489.
 416. Ĥuy (various), 553, 555, 556, 559, 675, 737, 824, 833, 834, 838.
 Ĥuy, *see* Amenħotp.
 417. Ĥuya, 667.
 418. Ĥuynūfer, 559.
 419. Ĥy, f. 774.
 Ĥy, *see* Iynefert.
 420. Ia, f. 796, 796.
 421. Ia (various), 793, 795.
 422. I'akhu, 878.
 423. Iarti (various), 622, 674.
 424. Iasen, 490.
 425. Iau, 505.
 426. Iay, 834.
 Iay, f. 875.
 427. Ia'y, f. 676.
 428. Ibebi, 678.
 Ibebi, *see* Sabu.
 429. Ibi (various), 509, 672.
 430. Iby, 546.
 Iby, *see* Nebt.
 Iby, *see* Serbykhen.
 431. Idi (Tepemkau), 680.
 432. Idi, 428, 678.
 Idi (others), 547, 676, 680.
 433. Idu (various), 419, 522, 547, 684.
 Idu, *see* Meri.
 Idu, *see* Nebkauħor.
 434. Idut, f. 623.
 Idut, *see* Sesheshet.
 435. Idu-tepiħu, 683.
 436. Idy (various), 547, 739.
 437. Ifefi (Fefi), 449.
 Ifi, *see* Seshemūfer.
 438. Iħat, f. 697.
 439. Iħsetpep, f. 866.
 440. Ihy, 808.
 441. Ihy, 527, 529, 534.
 Ihy, 617, 618, 619.
 Ihy, 646, 646.
 Ihy (others), 547, 547, 551, 625, 629, 632, 651, 673, 688.
 Ihy, *see* Irenrē'.
 442. Ihyemsaf, 536, 536, 536.
 443. Ihykhent, 428.
 444. Iħynes, 633.

- Ihynes, *see* Meryrēc-ankh.
 445. Ikenwesh, 770, 771.
 446. Iker, 878.
 447. Ikerhathor, f. 550.
 448. Ikhekhi (various), 510, 511.
 Ikhekhi, *see* Khentka.
 449. Ikhi (various), 432, 640.
 450. Ikri (Nebsen), 768.
 451. Ikri, 432, 433, 686.
 Ikri (others), 433, 544, 547, 547, 608, 610.
 452. Iku, f. 544.
 Iku, *see* Nefer(t)kaus.
 Ima, *see* Imapepy.
 453. Imai (various), 547, 567.
 454. Imaia, f. 871.
 455. Imameryrēc (Imapepy), 683.
 456. Imapepy (Ima), 428, 679.
 457. Imapepy (others), 682, 687.
 Imapepy, *see* Imameryrēc.
 458. Imaseshet, 403.
 459. Imat, f. 544.
 460. Imbi, 610.
 461. Imes, 829.
 462. Imhōtep, later deified, 407, 417, 571, 766, 777, 817, 869.
 Imhōtep (others), 537, 547, 573, 651, 651, 722, 734, 747, 764, 795, 796, 796, 796, 802, 802, 802, 812, 813, 824.
 Imhōtep, *see* Pedubaste.
 463. Impy (Hneni), 569.
 464. Impy (others), 428, 688, 852.
 Impy, *see* Ptahshepses.
 465. Impy'ankh, f. 852.
 466. Impy-sokari, 564.
 467. Imti, 506.
 468. Imu, f. 739.
 469. Imut, 810.
 Imut, f. 793, 793, 794.
 470. Imy, 629.
 471. Imy (?), 547.
 472. In, f. 593.
 In, *see* Ipi.
 473. Inamūn-nefnebu (Nefer-
 ebrēc-sineit), 802.
 474. Inba, 506.
 475. Inbi, 562.
 476. Inenay, 845.
 477. Inhertmosi, 859.
 Init, *see* Intiotes.
 478. Inneferhathor, f. 611.
 Inpu, *see* Inpuemhēt.
 479. Inpuem'ankh, 493.
 480. Inpuemhēt (Inpu), 549.
 481. Inpuemhēt, 562.
 482. Inpuemhēt-wēr, 565.
 483. Inpuemsaf, 565.
 484. Inpukha', 586, 691.
 485. In-snefru-ishtef, 891.
 Int, *see* Inti.
 Inthi, *see* 'Ankhi.
 486. Inti (Int), f. 692.
 487. Inti, 823.
 Inti, f. (various), 460, 463, 508, 569, 646.
 488. Intiotes (Init), f. 567.
 489. Intkaes, f. 407, 414.
 Inu, *see* Nefertere.
 490. Iny, 547, 547.
 Iny (others), 548, 667, 850.
 Iny (*i.e.* Mutemōnet), f. 838.
 Iny, f. 518.
 491. Iny'ankh, 465.
 492. I'oḥ, 812.
 493. I'oḥardai[s], 802.
 I'oḥardais, f. 746.
 494. I'oḥ-neferu, f. 798.
 495. I'oḥweben (?), 810.
 496. Ip, 794.
 Ip, f. 881.
 Ip, *see* Akhi.
 497. Ipa, f. 859.
 498. Ip'ankhef, 547.
 499. Ipay, 572.
 500. Ipdy, 740.
 501. Ipet, f. (various), 734, 880.
 502. Ipi (In), 563.
 503. Ipi (others), 451, 540, 544, 546, 548, 551, 560, 564, 564, 569, 569, 671, 676, 729, 867, 880.
 Ipi, f. (various), 545, 740, 769.
 Ipi, *see* Akhtihotp.
 Ipi, *see* Ipi'ankhu.
 Ipi, *see* Ipiemsaf.
 Ipi, *see* Ipiemsas.
 Ipi, *see* Ipi-haishtef.
 Ipi, *see* Ipihirsesenbef.
 Ipi, *see* Ipiisenbes.
 Ipi, *see* Ra'herka.
 Ipi, *see* Si-hathor.
 504. Ipi'ankhu (Ipi), 540.
 505. Ipi'ankhu (others), 517, 517, 540, 540, 540, 563, 563, 564, 564, 569.
 506. Ipiemsaf (Ipi) (various), 561, 567.
 507. Ipiemsaf (others), 548, 565.
 508. Ipiemsas (Ipi), f. 544.
 509. Ipiem . . ., 547.
 510. Ipi-haishtef (Ipi), 570.
 511. Ipi-hirmenkhet, 570.
 512. Ipihirsesenbef (Ipi) (various), 538, 747.
 513. Ipihirsesenbef, 544.
 514. Ipiisenbes (Ipi), f. 558.
 515. Ipiisenbes, 564.
 Ipiisenbes, f. 569.
 516. Ipti, 897.
 Ipi-uzau, *see* Akhtihotp.
 517. Ipka, 436.
 518. Ipti (various), 605, 608, 608.
 Ipti, *see* Ptahhotp.
 519. Ipu, 807.
 520. Ipu, f. 557.
 521. Ipuia, 555.
 522. Iput I, f. 396, 568, 570.
 523. Iput II, f. 432.
 524. Iputi, 794.
 525. Ipuwēr, 571.
 526. Ipuy, f. 718.
 527. Ipy, 702, 704.
 Ipy (others), 770, 783, 834, 867.
 528. Ir, 770.
 529. Ir'aḥap (various), 787, 790, 791, 791, 795, 812.
 530. Ir'aheka (various), 801, 827.
 Ir'aheka, *see* 'Ahmosi-men.
 531. Ir'aḥor (Neferebrēc-nūfer), 588, 849, 861.
 532. Ir'aḥor (. . . ḥap), 800.
 533. Ir'aḥor (others), 591, 591, 591, 771, 772, 794, 800, 813.
 534. Iref'aenptaḥ (various), 771, 788, 799, 808, 866.
 535. Iref'aenubaste, 816.
 536. Irenakhti, 601.
 537. Irenes, 736.
 Irenes, *see* Pepysonb.
 538. Irenḥor, 803.
 539. Irenkaptaḥ, 644.
 540. Irenptaḥ (various), 419, 447.
 541. Irenrēc (Iḥy), 760.
 542. Irensen, 736.
 Irery, *see* Bia.
 543. Iresh, 826.
 544. Irḥap, 651, 794.
 545. Irḥepiaut, 808, 816.
 546. Iri (various), 544, 569, 569, 676, 689.
 Iri, *see* Meryrēc-ankh.
 Iri, *see* Sebkhotp.
 547. Iris, 722.
 548. Irisethet, 442.
 549. Irneferenptaḥ, 805.
 550. Irsentay (Arsinoë), f. 743.
 Irt, *see* Irt-nub.
 551. Irtenḥarerau, 766.
 552. Irterau (various), 652, 764, 810, 826, 849.
 Irterau, f. 800, 802.
 Irterau, f. 804, 811.
 Irterau, f. (others), 573, 587, 613, 650, 719, 749, 788, 809, 812, 812, 813, 814, 815, 816, 816, 831.
 553. Irtharerau (various), 812, 872.
 554. Irti, f. (various), 762, 769, 799.
 Irti-teti'ankh, *see* Kheti.

555. Irt-nub (Irt), f. 564.
 556. Irt-nub, f. (others), 541, 722, 723.
 557. Irt-ptah (Iry), 746.
 558. Irt-sobk, f. 646, 646.
 559. Irtubaste, f. 573.
 Irt, *see* Ni'ankh-irty-pepy.
 560. Iru (various), 592, 793.
 561. Irukaptah (Khenu), 639.
 562. Irukaptah, 691.
 563. Irut, f. 678.
 564. Iry (various), 667, 692, 808, 839.
 Iry, *see* Irt-ptah.
 565. Iryiry (various), 572, 756.
 566. Isbu, 826, 826.
 567. 'Iseš', 672.
 568. Iseš'ankh, 489, 497.
 569. Isešikha'ef, 394, 419, 753.
 570. Isešizedef, 419.
 571. Isha'et, f. 479.
 572. Ishefi (Tutu), 513, 515.
 573. Ishethi (Thethi), 609.
 574. Ishetma'et, 508, 511.
 575. Isi, 626.
 Isi, 736, 739.
 Isi, *see* Washptah.
 576. Isi, f. 610.
 577. Isi'ankh, 742.
 578. Ismet, f. 898.
 579. Isti, f. 676.
 580. It, 792, 793, 793, 794.
 581. Itefnūfer, 572.
 582. Itehi, 735.
 583. Itep, 722.
 584. Iteti ('Ankhiris), 598.
 585. Itety, f. 547.
 586. Ithi (various), 768, 895.
 Ithi, *see* 'Ankhi.
 587. Ithu, 543.
 588. Ithy, 683.
 589. Iti (Khentkaus), f. 674.
 590. Iti (others), 450, 491, 567, 676, 677, 692, 774, 878.
 Iti, f. 456, 465.
 Iti, f. (others), 478, 548, 623, 886.
 Iti, *see* Ptaħ'ankhu.
 Iti, *see* Rē'herterp.
 591. Itisen (various), 448, 652, 727.
 592. Itit, f. 675.
 593. Itiwert, f. 886.
 594. Itneferu, f. 847.
 Itwesh, *see* Smenkhuptah.
 595. Ity (Duarē), 611.
 596. Iuf'a, 800, 815.
 Iuf'a (others), 794, 866.
 597. Iuf'ankh (various), 787, 808.
 598. Iuf'ankh-nūfer, 823.
 599. Iufenmutf, 544.
 600. Iufhes, 404.
 601. Iufni, 545.
 602. Iuiu, 808.
 603. Iuiu, f. 686.
 604. Iurez, 567.
 605. Iurokhy, 661.
 606. Iuti, 732.
 607. Iuy, 661.
 608. Iuy, f. (various), 707, 745, 746.
 609. Iy, 622, 625.
 Iy (others), 556, 565.
 Iy'adru (?), *see* Userpeħ-tinesu (?).
 610. Iyemia, f. 668.
 611. Iyenhōr, 630.
 612. Iyhethek, 774.
 613. Iyiry, 704, 845, 865.
 614. Iyka, 637.
 615. Iyka-nezes (?), 749.
 616. Iykau (various), 419, 457.
 617. Iymert, f. 637.
 618. Iymery, 505, 506.
 Iymery, 761.
 619. Iyefert (Hy), f. 768.
 620. Iyefert, 616.
 Iyefert, f. 482.
 621. Iyefertenptah, 827.
 Iyni'ankh, *see* Ptaħhotp.
 622. Iynikhnum, 402, 404, 416, 440, 440.
 623. Iynūfer, 894.
 624. Iyu, 774.
 625. Iywat, 502.
 626. Iywen (Sekhentiuka), 739.
 627. Iyzefa, 579.
 628. Ka (various), 649, 816.
 629. Ka'ahaf, 890.
 630. Ka'aper, 470, 470.
 Ka'aper (others), 459, 501, 762.
 631. Kaemħest (various), 499, 542.
 632. Kaemib, 895.
 633. Kaemķed, 895. *See also* Kaiemķed.
 634. Kaemnefert, 467.
 635. Kaemreħu (various), 485, 690.
 636. Kaemsenu, 541.
 637. Kaemthenen, 768.
 638. Kaemthenent (various), 489, 692.
 639. Kaennebti, f. 494, 497.
 640. Kaḫiriati, f. 706.
 641. Kagemni (Memi or Gemni), 521, 546, 546.
 642. Kagemni (others), 546, 548, 551.
 643. Kagem . . ., 548 (same man as No. 641).
 644. Kaħa, 639.
 645. Kaħa[ishutef ?], 872.
 646. Kaħersetef (various), 693, 895.
 647. Kaħif, 722.
 648. Kaħotp, 622.
 649. Kai (Seni), 615.
 650. Kai (others), 458, 479, 507, 767.
 651. Kaia, f. 745.
 652. Kai'ankh, 641.
 653. Kaiemķed (various), 478, 494. *See also* Kaemķed.
 654. Kaiħap (Kaiħap-wēr), 690.
 655. Kaiħap, 448.
 Kaiħap-wēr, *see* Kaiħap.
 656. Kairer, 631.
 657. Kairi, 668.
 658. Kakai-ħa(?)ishstef, 747.
 659. Kakhent, 542.
 Kakhent, *see* Kakhentiu.
 660. Kakhentiu (Kakhent), 768.
 661. Kama, 733.
 662. Kamosi, 746.
 663. Kanebef (*or* Kasinebef), 448.
 664. Kanenebef, 404.
 665. Kanenebfui (Khenu [I]), 537.
 666. Kani, 446.
 667. Kanūfer, 768, 769.
 Kanūfer (others), 419, 498, 651, 813, 821, 893, 893.
 668. Kapes, f. 792.
 669. Kapespu, f. 772.
 670. Kapuinpu (various), 579, 586.
 671. Kapunesut, 542, 543.
 672. Kapuptah, 693.
 673. Kapurē, 455.
 674. Ķar (various), 397, 419, 570.
 675. Karenen, 560, 560, 560.
 Karenen, 563.
 676. Kares, 895.
 677. Kasa (various), 737, 745.
 678. Kaseshem, 601.
 Kasinebef, *see* Kanebef.
 679. Katep (various), 693, 693.
 680. Kauemperptah, 859.
 681. Kauza, 736.
 682. Kawatb (various), 864, 893.
 683. Kawehem, 466.
 684. Kawez'ankh, 894.
 685. Kay (various), 463, 771.
 686. Ķebħatenēsi, f. 793.
 687. Ķedi, f. 630.
 688. Ķednas (various), 456, 580, 585, 823.
 689. Ķedshepses, 893.
 690. Ķeķuiry, f. 831.
 691. Ķema, 751.
 692. Keminub, f. 886.
 693. Kemkap, 809.

694. Kēn, 833.
 695. Kēnamūn, 819.
 696. Kēnhirkhopshef, 559.
 697. Kēna, 734.
 698. Kēnakht, 559.
 699. Keramama, f. 722, 785, 846, 875.
 700. Keref, 795.
 701. Kēreferptah, 788.
 702. Keref-ptah, 808.
 703. Kērfamūn, 792.
 704. Kērfet, f. 614.
 705. Kerhi, f. (various), 878, 880.
 706. Kēwenēsi, f. 815.
 707. Kha^c (various), 559, 871.
 708. Kha^cbaukhnun (Biu), 684.
 709. Kha^cbauptah, 453.
 710. Kha^cbausokar (Hethes), 449.
 711. Kha^cemwēset (Kiauia), 737.
 712. Kha^cemwēset, son of Ramesses II, 398, 400, 421, 434, 572, 703, 704, 782, 782, 817, 818, 819, 832, 832, 838, 840, 850, 855, 864, 871, 871, 872.
 Kha^cemwēset (others), 814, 858, 859, 861.
 Kha^cemwēset, see Hātiay.
 713. Kha^cfi, 764.
 714. Kha^chap, 744, 744, 747.
 Kha^chap (others), 506, 738.
 715. Khai, 675.
 716. Kha^ckheperrē^c-sonb, 897.
 717. Kha^cma^cet, f. 464.
 718. Kha^cmererptah, 481, 481.
 719. Kharkhons, 869.
 720. Kharu, 859.
 721. Kharuef (various), 552, 732.
 722. Kha^csuenamūn (various), 788, 790.
 723. Kha^csuenēsi, 810.
 724. Kha^csumin, f. 810.
 725. Khaut, f. 742.
 726. Kha^cy (various), 572, 726, 733, 733, 859.
 727. Kha . . ., 816.
 728. Khedebneit-yerboni [II], f. 670.
 729. Khedeb-yerboni, f. (others), 814, 815.
 730. Khemeny, 548.
 731. Khemtnu, 769.
 732. Khensardais (various), 793, 798.
 733. Khensia (?), 572.
 734. Khensiu (various), 650, 651, 651, 743.
 735. Khens-iuemma^cet (?), 651.
 Khent, see Khentetka.
 736. Khentekhtaiemsaf, 896.
 737. Khentemhēt, 565.
 738. Khentetka (Khent), f. 894, 895.
 739. Khentetka, f. (others), 490, 568, 578.
 740. Khenti, 530.
 741. Khenti, f. 892.
 742. Khentiuka (various), 878, 878, 879, 899, 899.
 743. Khentka (Ikhekhi), 508.
 744. Khentka [I], see Kanenebfui.
 745. Khentkauhor, 629.
 746. Khentkaus, f. (various), 581, 596, 614, 641, 641, 699, 758.
 Khentkaus, see Iti.
 747. Khentni, 567.
 748. Khent-siennebta (?), 726.
 Khenu [I], see Kanenebfui.
 749. Khenu [II] (Themī), 537.
 750. Khenu, 727, 727.
 Khenu (others), 427, 488, 526, 561, 567, 567, 625, 640, 652, 731.
 Khenu, see Irukaptah.
 Khenu, see Neferseshem-seshet.
 751. Khenu, 686.
 752. Khenuhotp, 552.
 753. Khenu-ib, 738.
 754. Khenukhuit, f. 511.
 755. Khenut, f. 485, 494.
 Khenut, f. (others), 452, 457, 489, 547, 577, 623, 641, 644, 698, 826.
 756. Kheperkarē^c, 673.
 757. Kherepka, 446.
 758. Khertnef, 448.
 759. Khet, 765.
 Kheter, see Takher.
 760. Kheti (Irti-teti^cankh), 563.
 Khetui, see Neferkarē^c-nakht.
 761. Khety (various), 564, 564, 567, 687, 751.
 Khety, f. 571.
 762. Khnem^cankhu (Pepy . . .), 604.
 763. Khnem^cankhu, 768.
 764. Khnemebrē^c, 802, 810.
 Khnemebrē^c-men, see Henat.
 765. Khnemebrē^c-siptah (Nekau), 803.
 Khnementi, see Khnemu.
 766. Khnemhotp, 398, 578.
 Khnemhotp, dwarf, 722.
 Khnemhotp (others), 394, 428, 449, 458, 518, 641, 678, 684, 684, 687, 896, 897.
 Khnemi, see Ni^cankh-khnun.
 767. Khnemiotef, 405.
 768. Khnemnakht, see Khuenkhnun and Khuikhnum.
 769. Khnemnūfer, f. 809.
 770. Khnemt, f. 641.
 771. Khnemt, f. (others), 651, 689, 886.
 772. Khnemti, 674.
 Khnemti, see Khnementi.
 773. Khnemt-neferhezēt, f. 884.
 774. Khnemt-neferhezēt-^cat, f. 889.
 775. Khnemtneit, f. 506.
 776. Khnemu (Khnementi, *perhaps better*: Khnemti), 686.
 777. Khnum, 684.
 778. Khons (various), 675, 783.
 Khons, f. (various), 639, 880.
 779. Khons-hap, 764.
 780. Khredni, 678, 679.
 781. Khredu^cankh, f. (various), 744, 802.
 782. Khubau, 742.
 783. Khubawy, 685.
 784. Khuenkhnun, 419.
 Khuenkhnun (*incorrect*: read Khnemnakht), 562.
 785. Khuenptah (various), 428, 569, 689, 736, 760.
 786. Khuensobk, 646.
 787. Khui, 626, 627, 627, 627.
 Khui, 428, 519.
 Khui (others), 547, 548, 548, 769.
 Khuikhnum (*incorrect*: read Khnemnakht), 771.
 788. Khuirē^c, 442.
 789. Khuit, 684.
 Khuit, f. (various), 397, 482, 492, 545, 568.
 Khuit, see Khuit-khente-khtai.
 790. Khuit-ba, f. 570.
 791. Khuitenba, f. 610.
 792. Khuit-khentekhtai (Khuit), f. 517.
 793. Khuit-khnun, f. 540.
 794. Khui(t)neit, f. 570.
 795. Khuitptah, 404.
 796. Khuit[rē]^c, f. 821.
 797. Khunesu, f. 893.
 798. Khuties, f. 427.
 799. Khuwennefer, 788.
 800. Khuwi, 518.
 801. Khuwi-inpu, 405.
 802. Khuwiptah, 762.
 803. Khuwisobk, 563.
 804. Khuy (various), 563, 607, 768.
 Kiauia, see Kha^cemwēset.
 805. K̄isutet (Niwezēt-denu), f. 545.

806. Kitsen, f. 489.
807. Ky, 567.
808. Maḥu (various), 556, 821.
Maḥu, f. (various), 557, 734.
809. Maḥuia (?), 834.
810. Maḥuy, 708, 727.
Maḥuy, 752.
811. Maia, 675.
Maia, f. (various), 712, 715.
812. Mamin, 404.
813. Manüfer, 456, 466.
Manüfer (others), 575, 768.
814. Maru (Bebi), 694.
815. Maru, 678.
816. May (various), 737, 781, 857.
May, f. (various), 664, 702, 747.
817. Maya, 661.
Megui, *see* Gemni.
818. Meḥamenwia, 794.
819. Meḥi (various), 570, 682.
820. Mehu (various), 546, 567, 619, 623.
821. Mehyt, 545.
822. Mehytardais, f. 795.
823. Mehytwërt-nebt'ankh, f. 813.
824. Meket (various), 878, 878, 879, 880.
Meket, f. 880.
825. Meket'ankh, 879.
826. Mem, 803.
Mem, *see* Metety.
827. Memi (Pepy'ankh), 527, 530, 532, 534.
828. Memi (others), 542, 652, 683, 795.
Memi, *see* Kagemni.
829. Men, 790.
830. Menamenrëc, f. 831.
831. Men'ankh-pepy (Meni), 565.
832. Menekh-ḥaṭḥor, 564.
833. Menekh-ishet, 769.
Meni, *see* Men'ankh-pepy.
834. Meniuser, 828.
835. Menka, 404.
836. Menkheper, 712, 727.
837. Menkheperra'sonb, 865.
838. Menkhib-wehebrëc, 811.
839. Ment, f. 883, 883.
840. Mentuemwëset, 559.
841. Mentuhotp (various), 571, 672, 725.
842. Meramün-tables, f. 670.
843. Merenptah, 805, 806 (*as* Merneptah).
Merenptah (others), 559, 733, 737, 785, 833 (*sometimes as* Merneptah).
- Merenptah, *see also* Merneptah.
844. Merenrëc, 429.
845. Merenrëc'sonb, 674.
846. Mereret (Meryt), f. 884.
847. Mereri (various), 518, 607, 687.
Mereri, f. 723.
848. Mereru (various), 405, 567, 604, 644.
849. Mereruka (Meri), 525, 546, 569.
850. Mereruka (Metetu), 452, 506.
851. Mereruka, 676.
Merery, *see* Herimeru.
852. Mereryt, f. 897.
853. Meres'ankh, f. (various), 488, 688, 736, 895.
854. Meresh, 826.
855. Meri (Idu), 742.
856. Meri (others), 548, 879.
Meri, f. 568.
Meri, *see* Mereruka.
Meri, *see* Meryteti.
857. Merib, 587, 848.
Merib (others), 746, 768.
858. Meribenptah, 651.
859. Merihu, 783.
Merit, *see* Mertioties.
860. Merka, 446.
861. Merneit-wehebrëc, 732.
862. Mernekhu, 557.
863. Merneptah, later King, 784, 868.
Merneptah, *see* Merenptah.
864. Merneter-nesut, 761.
865. Mernubtiotes, f. 812.
866. Merptah, 651.
867. Mersurëc, 816.
868. Mert, f. (various), 569, 687.
Mert, *see* Mert-teti-iyt.
869. Mert, f. 674.
870. Mertib, f. 693.
871. Mertioties (Merit), f. 564.
872. Mertioties, f. (others), 492, 505, 639, 692, 727, 798, 894.
873. Mertiyyt, f. 563.
874. Mert-min (Ḥenutsen), f. 768.
875. Mertmin, f. (others), 440, 448.
876. Mertneit, f. (various), 565, 670.
877. Mer(t)ptah, f. 771.
878. Mert-teti-iyt (Mert), f. 563.
879. Mert-teti-iyt, 564.
880. Meru (Tetisonb, Meryrëc'sonb or Pepysonb), 520.
881. Meru (others), 424, 548, 652, 732.
882. Meruka, 484.
883. Merut, f. 606.
884. Mery (various), 446, 501, 501, 549.
885. Merya, 557.
886. Mery-inḥer(t), 887.
887. Mery-isesi, 615.
888. Merymery (various), 705, 870.
889. Merynemti, 675.
890. Merypepy, 546.
Merypepy, *see* Degem.
891. Mer(y)ptah, 812, 814.
Meryptah (others), 395, 706, 712, 733, 743.
892. Meryrëc (various), 556, 572, 687, 706, 833.
893. Meryrëc'ankh (Ḥëkaib), 545.
894. Meryrëc'ankh (Iri), 570.
895. Meryrëc'ankh (Iḥynes), 586.
896. Meryrëc'ankh, 621.
897. Meryrëc'sonb, 568.
Meryrëc'sonb, *see* Meru.
Meryrëc-zedi, *see* Pepy-zedi.
898. [cancelled]
899. Merysekhmet (various), 858, 870.
900. Meryt, f. 661.
Meryt, *see* Mereret.
901. Merytamün, f. 504, 863.
902. Meryteti (Meri), 526, 528, 529, 529, 530, 534, 535 (10 times), 536.
903. Merytneit, f. 773.
904. Merytptah, f. (various), 669, 705, 709, 794, 814.
905. Mery(t)-sekhmet, f. 556.
Merytyaten, *see* Merytneit.
906. Merytneit (Merytyaten), 666.
Meryunu, *see* Raṣmeses-emperrëc.
907. Meseḥti, f. 458.
908. Mesenka, 403.
909. Meṣhotp, 816.
910. Mes-sa, 736.
911. Messuy, 572.
912. Mesthu, 824.
913. Mesti, f. 611.
914. Mestni, f. (various), 548, 570.
Mestni, *see* Theset.
915. Mes-unnüfer, 806.
916. Meteti, 545.
Metetu, *see* Mereruka.
917. Metety (Mem), 568.

918. Metety, 548.
 919. Methefi (Akhu), 511.
 920. Methen, 493.
 921. Methethi, 646.
 922. Methu, 736.
 923. Methut, f. 596.
 924. Methut (?), f. 548.
 925. Mezedka, 446.
 926. Mia, f. 734.
 927. Mimeth, 756.
 928. Minardais (?), 844.
 929. Minhotp (Hetutu), 737.
 930. Miniry (?), 557.
 931. Minkha'y, 657.
 932. Minmessu, 740.
 933. Minmosi (various), 734, 744, 749.
 934. Minnakht (various), 557, 774, 837.
 935. Minnüfer (various), 465, 586, 764.
 936. Min-snefru-sheri, 879.
 937. Mitri, 632.
 938. Mosi (various), 553, 822, 859, 871.
 939. Mut, f. 737.
 940. Mutardais, f. (various), 771, 798, 801, 815, 831. Mutemönet, *see* Iny.
 941. Mutemas, f. 549.
 942. Mutemwia, f. (various), 733, 735, 844.
 943. Mut-hetepi, f. 543.
 944. Mutiyti, f. 763.
 945. Mutnefert, f. (various), 553, 675, 728, 823.
 946. Mutnezemt, f. 819.
 947. Mut-pipu, f. 706.
 948. My, f. 502.
 949. M . . . , 569.
950. Na'a-tesnakht, f. 791.
 951. Naḥerḥu (various), 572, 573.
 952. Naḥuḥer, 661, 661, 662, 662.
 953. Naia, f. 820.
 954. Nakht (various), 661, 666, 747, 768, 828.
 955. Nakhtes, f. 764.
 956. Nakht-snefru, 879.
 957. Nakhty (various), 568, 675.
 958. Nana (various), 793, 807.
 959. Nany, f. 737.
 960. Nashatyf, f. 666.
 961. Nashwuy, 434.
 962. Na'su, 806.
 963. Nay, f. (various), 573, 771.
 964. Na' . . . , 771.
 965. Neb'an(en)su, 557.
 966. Neb'ankh, 746. Neb'ankh, *see* Zehō.
 967. Neb-ḥepar-bener (?), 650, 651.
 968. Nebi (Nebipu-pepy), 678.
969. Nebi (others), 538, 684. Nebi, *see* Nebu.
 970. Neb(i)pu-pepy (Seni), 681. Nebipu-pepy, *see* Nebi.
 971. Nebishet, 447.
 972. Nebkauḥor (Idu), 627.
 973. Nebmehyt, 552.
 974. Nebmosi, 759.
 975. Nebnakht, 395.
 976. Nebneḥeḥ, 726.
 977. Nebrē', 676.
 978. Nebsen, 736. Nebsen, *see* Ikri.
 979. Nebsent, f. 493.
 980. Nebt (Iby), f. 519.
 981. Nebt, f. (others), 536, 548, 619, 624, 641.
 982. Nebt-ḥet, f. 688.
 983. Nebt-ḥyt, f. 764.
 984. Nebtka, 442. Nebtka, f. 769.
 985. Nebtkenb, f. 771.
 986. Neb(t)net, f. 745.
 987. Nebt-taui, f. 866.
 988. Nebty-nubkhet (Sesheshet), f. 521.
 989. Nebu (Nebi), 673.
 990. Nebuzat, f. 738.
 991. Nebwa'wi, 845.
 992. Neby, 684. Neby, *see* Sefekhptah.
 993. Nefarud (various), 612, 814.
 994. Neferebrēt (various), 748, 748, 798, 812, 813, 818.
 995. Neferebrēt-emakhet, 772. Neferebrēt-emakhet, *see* Hor.
 996. Neferebrēt-men, 802.
 997. Neferebrēt-merypthah (various), 800, 810, 814. Neferebrēt-nebpeḥti, *see* Uzaḥorresnet.
 Neferebrēt-nüfer, *see* Ir'ahor.
 998. Neferebrēt-sineit, 587, 848. Neferebrēt-sineit, 775. Neferebrēt-sineit, *see* Inamün-nefnebu.
 Neferebrēt-sineit, *see* Nekht-ḥarḥebi.
 Neferebrēt-sonb, *see* Paneḥesi.
 999. Neferen, 735.
 1000. Neferēsi, f. 573.
 1001. Neferḥer, 881. Neferḥer, *see* Neferḥor.
 1002. Neferḥerenptah (various), 451, 478, 637, 756.
 1003. Neferḥeres, 503. Neferḥeres, f. (various), 801, 811.
1004. Neferḥer-snefru, 892.
 1005. Neferḥetpes, f. 468, 577, 580, 736, 736.
 1006. Neferḥor (various), 503, 559, 687. Neferḥor, *see* Neferḥer.
 1007. Neferḥōtep (various), 451, 572, 604, 723, 755, 755, 814.
 1008. Neferḥōtep-ḥathor (Tepes), f. 449.
 1009. Neferḥōtepkhnum, 404.
 1010. Neferhy, 728.
 1011. Neferi, 683.
 1012. Neferirtnef, 583.
 1013. Neferirtnes (various), 487, 548, 892.
 1014. Neferirtptaḥ, 582.
 1015. Neferiru (various), 723, 768.
 1016. Neferka (various), 735, 768.
 1017. Neferkarēt (various), 429, 687. Neferkarēt-ankh, *see* Dersenez.
 1018. Neferkarēt-nakht (Khetui, Hetep), 680.
 1019. Neferkhatu, 572.
 1020. Neferkhaut, 865.
 1021. Neferkhent, 547.
 1022. Neferkhu, 673.
 1023. Neferkhuu, 568.
 1024. Neferkhuu-ptah (The-thi), 609.
 1025. Neferma'et (various), 878, 895.
 1026. Nefermerib, 446.
 1027. Neferonpet (various), 706, 706, 752, 783, 858, 859, 860, 866.
 1028. Nefersekheru, 557.
 1029. Nefersemdent, f. 560, 560.
 1030. Neferseenu, 546.
 1031. Nefersehem-psammethk (various), 802, 811, 852.
 1032. Nefersehemptah (various), 419, 453, 616, 645. Nefersehemptah, *see* Uzaḥateti.
 1033. Nefersehemrēt (Sheshi), 511.
 1034. Nefersehem-seshet (Khenu), 585.
 1035. Nefersehem-seshet, 419.
 1036. Nefersethes . . . , 758.
 1037. Nefershemem, f. 735.
 1038. Nefersobk, f. 748.
 1039. Nefert, f. (various), 565, 611, 652, 745, 823.
 1040. Nefertem, 735.

1041. Nefertem'ah, f. 698.
 1042. Nefertememsaf, 577.
 1043. Nefertemhotp, 792, 795.
 Nefertemhotp (others),
 732, 793, 796, 808, 848.
 1044. Nefertentes, f. 611.
 1045. Nefertere (Inu), f. 552.
 1046. Nefertere, f. 552, 552,
 553.
 Nefertere, f. (others),
 555, 738, 870.
 1047. Nefert-henut, f. 883.
 1048. Nefertthes, f. 732.
 1049. Neferti (various), 557,
 748.
 1050. Nefertiti, wife of Ameno-
 phis IV, f. 850, 857.
 Nefertiti, f. 770.
 1051. Nefertiyt, f. (various),
 743, 749, 749.
 1052. Nefer(t)kaus (Iku), f. 619.
 1053. Nefertnesut, f. 895.
 1054. Nefertni, f. 439.
 1055. Nefertwa, f. (various),
 545, 546.
 1056. Nefert-wenenes, f. 736.
 1057. Neferu, f. 592.
 1058. Neferwab, 543.
 1059. Neferwag, 547.
 1060. Neferweben, 865.
 1061. Nefer (various), 675,
 684, 686.
 1062. Nefer . . . ptaḥ, 810.
 1063. Neḥeḥ, 859.
 1064. Neḥeḥ-endisu, 783.
 1065. Neḥeḥeniotef, 733.
 1066. Neḥem'ay, 737.
 1067. Neḥemen, 552.
 1068. Neḥemesēsi, f. 819.
 1069. Neheri (various), 428,
 684.
 1070. Nehesi, 845.
 1071. Nehia, f. 833.
 1072. Nehyt, f. (various), 713,
 733, 737.
 1073. Neit, f. (various), 431,
 682.
 1074. Neitemḥēt, f. (various),
 772, 861.
 1075. Neithotp, 545.
 Neithotp, f. 547.
 1076. Neitīkert, f. 800, 815.
 1077. Neitiyti, f. (various), 720,
 801.
 1078. Neitnub, f. 858.
 Nekau, *see* Khnemebrēc-
 siptaḥ.
 1079. Nekau-mer(y)neteru, 816.
 1080. Nekau-mer(y)ptaḥ,
 801-2.
 1081. Nekhensu, 496.
 1082. Nekhtamūn, 571.
 1083. Nekht-dḥout, 763.
 1084. Nekhten . . . , 814.
 1085. Nekht-haremḥab, 795.
 1086. Nekht-harḥebi
 (Neferebrēc-sineit),
 866.
 1087. Nekhtnebef, 720.
 1088. Nekht-sas (various), 689,
 721.
 1089. Nekhtubasterau, f. (vari-
 ous), 798, 838, 866.
 1090. Nekhut (various), 681,
 681.
 1091. Nemareth (various), 788,
 788.
 1092. Nema (?), f. 820.
 1093. [cancelled]
 1094. Nemtiemsaf, 675.
 1095. Nemtiemzeref, 687.
 1096. Nemtimosi (various), 592,
 737.
 1097. Nemtinūfer, 451.
 1098. Nen . . . , f. 898.
 1099. Nena, 745.
 Nena, f. 708.
 1100. Nengem, 622.
 1101. Neni, f. 897.
 1102. Nenipepy (*perhaps better* :
 Nipepy), 427.
 1103. Nenkheftka (various),
 580, 580.
 1104. Nensia, 548.
 1105. Nensi . . . , 548.
 1106. Nermed, 573.
 1107. Nerseker, 826.
 1108. Neseḥka, 723.
 1109. Neshet, f. 716.
 1110. Neshi, 554.
 1111. Nesit, f. 675.
 1112. Neska, 499.
 1113. Nesmerut (Nesti), f. 681,
 681, 681.
 1114. Nesti, 677.
 Nesti, *see* Nesmerut.
 1114A. Nesumontu, 883.
 1115. Nes-userti, 546.
 1116. Nesutnūfer, 894, 895.
 1117. Neter'aperef, 879.
 1118. Neterkheperrēc-
 mer(y)ptaḥ (Paupau),
 853.
 1119. Neternūfer (various),
 570, 736.
 1120. Neteru'ankh (?), 879.
 1121. Neteruser, 485, 494.
 Neteruser, 494, 495, 495,
 495, 495.
 Neteruser (others), 485,
 497.
 1122. Net . . . , 568.
 1123. Nezem, 771, 838.
 Nezem, 861.
 1124. Nezemib (various), 611,
 746, 768.
 1125. Nezem-seshet, 824.
 1126. Nezem(t)-mennūfer, f.
 (various), 708, 732, 737,
 749.
 1127. Nezet, f. 783.
 1128. Nezetempot (Tit), f. 525.
 1129. Nezi, 638.
 1130. Nezui (?), 679.
 Ni, *see* Nipepy.
 1131. Nia (various), 707, 726.
 1132. Ni'ankhba, 629.
 1133. Ni'ankh-ḥathor, f. (vari-
 ous), 458, 565, 611,
 762, 768.
 1134. Ni'ankh-ḥor (various),
 549, 563.
 1135. Ni-tankh-irty-pepy
 (Irty), 739.
 1136. Ni'ankh-khnum
 (Khnumi), 630.
 1137. Ni'ankh-khnum (others),
 419, 641.
 1138. Ni'ankh-khons, 683.
 1139. Ni'ankh-meryrēc, 750.
 Ni'ankh-meryrēc, *see*
 Ni'ankh-pepy.
 1140. Ni'ankhnesut, 647 *note* 1,
 694.
 1141. Ni'ankhmin, 419.
 1142. Ni'ankh-pepy (Ni'ankh-
 meryrēc), 625, 630.
 1143. Ni'ankh-ptah (various),
 593, 601, 627.
 1144. Ni'ankhrēc, 586, 691.
 Ni'ankhrēc (others), 638,
 723, 890.
 1145. Ni'ankhrēc-nezes, 723.
 1146. Ni'ankh-sekhmet, 482.
 1147. Ni'ankh-snefru (Fefi),
 892.
 1148. Ni'ankh-tet, 741.
 1149. Ni'ankh-teti, 568.
 1150. Ni'ankhwazet, f. 501.
 1151. Niay (various), 707, 732.
 1152. Niḥebsed-neferkarēc, 683.
 1153. Niḥebsed-pepy, 680.
 1154. Niḥetep, 404.
 Nika, *see* Nipepy.
 1155. Nika'ankh (various), 398,
 505, 577, 723.
 Nikapepy, *see* Nipepy.
 1156. Nikarēc, 696.
 1157. Nikauḥathor, f. 457, 458.
 1158. Nikauḥor (various), 498,
 498, 592.
 1159. Nikauinpu, 760.
 1160. Nikauisesi, 419.
 1161. Nikaunebti, 769.
 1162. Nikaunub, f. 696.
 1163. Nikaupepy, 598.
 1164. Nikauptah (various), 633,
 744, 891.
 1165. Nikaurēc (various), 581,
 697, 697.
 1166. Nikhet, 548.
 1167. Nima'etptaḥ, 466.

1168. Nimaṭetrē, 480.
 1169. Nimaṭetsed, 584.
 1170. Nimesuptah, 723.
 1171. Nipepy (Nikapepy, Ni, Nika), 686.
 Nipepy, *see* Nenipepy.
 1172. Nisokari, 548.
 1173. Nisuḥen, 678.
 1174. Nisu-usert, 611.
 Niwezet-denu, *see* Kisu-tet.
 1175. Nofru, 548.
 1176. Nu, f. 572.
 1177. Nubemḥab, f. 738.
 1178. Nubemwaskhet, f. (various), 733, 859.
 1179. Nubḥetepti-khred, f. 889.
 1180. Nubḥotp (Bebi), f. (various), 483, 652.
 1181. Nubḥotp, f. 449.
 1182. Nubibnebti, f. 723.
 1183. Nubiyti, f. (various), 767, 804.
 1184. Nubka, f. 494.
 1185. Nubkaurē (various), 686, 687.
 1186. Nubkhet (?), f. 734.
 1187. Nubnebti, f. 479.
 1188. Nubnefert, f. 553.
 1189. Nūfer (various), 440, 502, 532, 639, 723, 769.
 1190. Nut-menkhet, 573.
 1191. Ny (various), 437, 741.
 1192. Paṭa, 592.
 1193. Paṭaenruz, 794.
 1194. Pa-ṭaha . . ., 573.
 1195. Paṭahaty, 828.
 1196. Pa-ani (various), 545, 545, 546, 546.
 1197. Paṭankhemthenen(t), 746.
 1198. Paṭankhi, 792.
 1199. Paṭazab, 806.
 1200. Paba . . ., 795.
 1201. Pade, 795.
 1202. Paensupesez, 810.
 1203. Pagerger, 708.
 1204. Paḥatiṭa, 845.
 1205. Paḥemneter (Pedeḥaremḥab), 733, 738.
 1206. Paḥemneter, HPM, son of Maḥuy, 571, 708, 727.
 Paḥemneter, HPM, 731.
 Paḥemneter, HPM, 871.
 Paḥemneter (others), 859, 860.
 1207. Paḥesa(?) (*probably better*: Paḥap), 808.
 1208. Paḥeter, 804.
 1209. Paḥethi (?), 806.
 1210. Paḥor, 825.
 1211. Paḥu, 871.
 1212. Paimt, 764.
 1213. Pain, 859.
 1214. Painmu, 503, 760.
 Painmu, 789, 791.
 Painmu (others), 803, 812, 814, 814.
 1215. Pairkap (Psammethek-[meryneit]), 813.
 1216. Pairkap (others), 795, 802.
 1217. Pairptaḥ, 881.
 1218. Pairsespet-khema-amūn (?), 808.
 1219. Paiuenḥor (various), 790, 791, 795, 799, 808, 815.
 1220. Pakap (various), 573, 795, 795, 803, 814, 817.
 1221. Paḳebeḥ, 845.
 1222. Paḳebesh, 795.
 1223. Paḳem, 746.
 1224. Paḳerer, 806.
 1225. Paḳer . . ., 861.
 1226. Paḳha, 813.
 1227. Paḳhar (various), 505, 795, 805. *See also* Paḳharu.
 1228. Paḳharkhons, 790.
 1229. Paḳharu (various), 748, 862. *See also* Paḳhar. Paḳharu, *see* Amenemḥab.
 1230. Pameriun (?), 765.
 1231. Pames, 651.
 1232. Panakht, 412.
 1233. Paneferiu, 793.
 1234. Paneferrekh (?), 815.
 1235. Paneḥemēsi, 766.
 1236. Paneḥesi (Neferebrē-sonb), 798.
 1237. Paneḥesi (others), 733, 772, 789, 790, 790, 795, 810.
 1238. Paneit, 506, 885.
 1239. Panūfer, 817.
 1240. Panūter, f. 735.
 1241. Papu, 848.
 1242. Paraṭarṭa, 791.
 1243. Paraṭemḥab, 771, 772.
 Paraṭemḥab, 751, 824.
 1244. Paraḥirwenemef, 737.
 1245. Paraḥotp (Raḥotp), 665.
 1246. Paṭṭashthereth (Paṭṭri), 862.
 Paṭṭri, *see* Paṭṭashthereth.
 Pasekhem, *see* ṬAnemḥo.
 1247. Pasenekhons (various), 790, 798.
 1248. Pasenḥor (various), 788, 788.
 1249. Paser, Vizier, 771, 783, 821, 838.
 Paser (others), 666, 725, 742, 763.
 1250. Paserpanub, 859.
 1251. Pashenēsi (various), 787, 789, 791, 794, 794, 808.
 1252. Pashenḥathor, 813.
 1253. Pashenḥor (?), 793.
 1254. Pash(en)mehyt, 790.
 1255. Pashenmut (various), 793, 793, 794, 795, 805, 872.
 1256. Pashenptaḥ (ṬAnkh-ḥap), 812.
 1257. Pashenptaḥ, HPM, 743, 744, 744, 744.
 Pashenptaḥ, 800, 815.
 Pashenptaḥ (others), 788, 789, 793, 795, 796, 799, 800, 801, 803, 803, 806, 812, 814, 814, 816.
 1258. Pashensekhmet (various), 791, 806, 809, 859.
 1259. Pashe(n)sekhmet-ṭankḥheka (?), 814.
 1260. Pashe(n)taisut, 592.
 1261. Pashentanaṭ (various), 795, 796.
 1262. Pashentiḥet (various), 720, 793, 812, 814, 814.
 Pashe(n)tiḥet, *see* Pede-neit.
 1263. Pasinu, 827.
 1264. Patenemḥab, 709.
 1265. Pathenfi, 798.
 Paupau, *see* Neterkhe-perrē-mer(y)ptaḥ.
 1266. Pawen (various), 789, 803, 804.
 1267. Pawenḥētef (Zehō), 504.
 1268. Pawenḥētef (others), 806, 808, 824.
 1269. Pawēr, 865.
 1270. Paweredu, 806.
 1271. Pay, 655, 663.
 Pay (others), 572, 808.
 1272. Payneferptaḥ, 859.
 1273. Peb-ḥep-weret (?), 651.
 1274. Pedamenōpet, 746.
 1275. Pedeamūn, 771, 772.
 Pedeamūn (others), 669, 789, 806.
 1276. Pedeamūn-paiat, 787.
 1277. [Pede]atum (?), 822.
 1278. Pedeḥarde, 795.
 1279. Pedeḥaremḥab, 800.
 Pedeḥaremḥab, *see* Paḥemneter.
 1280. Pedeḥarenpe, 793.
 1281. Pedeḥarkhebi, 816.
 1282. Pedeḥarmeden, 793.
 1283. Pedeḥarneziotef, 765.
 1284. Pedeḥarpekhrod (various), 765, 774, 803, 817.
 1285. Pedeḥarsemtu, 831.
 1286. Pedeḥeka, 765.

1287. Pedehenutpet, 859.
 1288. Pedehor (various), 588, 651, 735, 772, 803, 808, 824.
 1289. Pedehorenpe, 738.
 1290. Pedehorpashena^c, 592.
 1291. Pedekherbek, 809.
 1292. Pedekherbek . . ., 806.
 1293. Pedekhons (Pefteu-^cauenkhons), 767.
 1294. Pedekhons (others), 504, 747, 868.
 1295. Pedekhonsiy, 767.
 1296. Pedemiḥos, 867.
 1297. Pedenebwen, 814.
 1298. Pedenefertem (various), 791, 814, 814.
 1299. Pedeneit (Pashe(n)tiḥet), 591.
 1300. Pedeneit (others), 588, 649, 652, 735, 771, 795, 795, 816, 824, 861, 866.
 1301. Pedeneshmet, 824.
 1302. Pedenēsi (various), 612, 649.
 1303. Pedepamenkh, 824.
 1304. Pedepamenkhib, 766.
 1305. Pedepaneshmet, 824.
 1306. Pedepenpen, 816.
 1307. Pedepem (various), 565, 734, 811, 868.
 1308. Pedepṭaḥ (various), 793, 795, 800, 811.
 1309. Pederē^c, 791.
 1310. Pedes (various), 790, 791, 793, 803, 803, 808, 809, 809, 811.
 1311. Pedēsi (Ḥarkhebi), 866.
 1312. Pedēsi, 720, 720.
 Pedēsi, 786, 786, 847, 847, 866.
 Pedēsi, 804, 811.
 Pedēsi (others), 573, 747, 763, 771, 793, 793, 802, 803, 806, 806, 808, 808, 811, 816, 816, 822, 824, 824, 867.
 1313. Pedesiptaḥ, 795.
 1314. Pedesopdu (various), 806, 823.
 1315. Pedetaiḥet, 740.
 1316. Pede . . . (various), 795, 817.
 1317. Pede . . . (?), 810.
 1318. Pedubaste (Imḥōtep), 744.
 1319. Pedubaste (Weḥebrē^c), 866.
 1320. Pedubaste (others), 738, 743, 790, 793, 801, 809, 814, 816, 825, 827.
 Pedubaste, *see* Esisut.
 1321. Pedusiri (various), 765, 793, 795, 795, 807, 819, 826, 868, 885.
 1322. Pedusiri-pewaḥ, 793.
 1323. Pedusiriwēr-nūfer, 803.
 1324. Pef^ca-hor (?), 790.
 1325. Pefḥerinūter (various), 793, 793, 793, 793, 795, 818, 824.
 1326. Pefiu, 734.
 1327. Pefneferiu, 808.
 1328. Pefneit, 799.
 1329. Pefteu (various), 738, 793.
 1330. Pefteu^cau-amūn (Psammethēk-nūfer), 839.
 1331. Pefteu^caubaste (various), 793, 801, 802, 808, 813, 822.
 Pefteu^caubaste, *see* Pedekhons.
 Pefteu^caubaste, *see* . . . wep^cau, 801.
 Pefteu^cauenkhons, *see* Pedekhons.
 1332. Pefteu^cauēsi, 795, 814.
 1333. Pefteu^caukhons (various), 505, 803, 806, 811, 814.
 1334. Pefteu^caueneit (various), 817, 848.
 1335. Pefteu^caupep, 652.
 1336. Pefteu^c(au)shu, 767.
 1337. Pef^ci, 796.
 1338. Pef . . ., 807.
 1339. Peḥenptah, 403, 405.
 1340. Peḥernūfer, 465, 466.
 Peḥernūfer, 634, 634.
 Peḥernūfer (others), 502, 541.
 Peḥernūfer-pakhem, *see* Aperenyas-pakhem.
 1341. Peḥnūfer, 632.
 1342. Peḥnuika, 491.
 1343. Peḥ^ca, 817.
 1344. Peḥen, 815.
 1345. Peḥmes-sethet, 436.
 1346. Pemu, 789, 789.
 Pemu (others), 786, 808, 814, 814, 817.
 1347. Pen^caḥer, f. 792.
 1348. Penamenōpet, 793.
 1349. Penameny (?), 808.
 1350. Penamūn (various), 733, 735, 792, 793, 818, 881.
 1351. Pendua, 755.
 1352. Penen, 861.
 1353. Penēsi (various), 765, 789.
 1354. Pen-ḥarwoz, 790.
 1355. Penmeḥy, 572.
 1356. Penmeḥyt, 860.
 1357. Pennebt-nehēt, 792.
 1358. Penpa . . ., 573.
 1359. Penptah (various), 797, 806.
 1360. Penrennut, 669.
 1361. Pensekhmet, 799.
 1362. Pentahayet, 815.
 1363. Pentaōnet, 790.
 1364. Pentashendyt, 822.
 1365. Pentawēr, 687.
 1366. Pentazer, 789.
 1367. Pentent-khebi (various), 806, 823.
 1368. Penu, 681.
 1369. Penweben-tanakht (?), 774.
 1370. Penyunu, 675.
 1371. Penzerti, 838.
 1372. Pepi, 548.
 Pepi, 677, 677.
 Pepi, f. 506.
 1373. Pepy, 560.
 1374. Pepy^cankh (Sethu), 672.
 1375. Pepy^cankh (others), 426, 427.
 Pepy^cankh, *see* Memi.
 1376. Pepyemḥēt, 683.
 1377. Pepy-ma^ciu, 570.
 1378. Pepy-meriotes, f. 798.
 1379. Pepyinakht, 426.
 1380. Pepysonb (Irenes), 736.
 1381. Pepysonb, 426.
 Pepysonb, *see* Meru.
 1382. Pepyzedi (Meryrē^c-zedi, Zadi), 596.
 Pepyzedi, *see* Tetizedi.
 1383. Pepy . . ., 688.
 Pepy . . ., *see* Khnem-^cankhu.
 1384. Perka, 814.
 1385. Perneb (various), 497, 613, 823.
 1386. Pernezu, 611.
 1387. Pernikai, 403.
 1388. Pernūfer, 505.
 1389. Person, 577.
 1390. Perti, f. 676.
 1391. Peru, 768.
 1392. Pesedet, f. 765.
 1393. Peshedu, 571.
 1394. Pespermeḥ, 771.
 Pespermeḥ, f. 810.
 1395. Pesteu^caunu, f. 766.
 1396. Petekhtekh, 405.
 1397. Petetheb, 739.
 Petety, *see* Sebkhōtp.
 1398. Pewaḥ, 675, 675.
 1399. Pezai (various), 786, 789, 789.
 1400. Philotera, f. 743, 818.
 1401. Piamūn, 831.
 1402. Piay, 782 *note* 1, 783, 784, 784.
 Piay (others), 737, 775, 849, 865.
 1403. Pikha^cs, 862.
 1404. Pinezem, 858.
 1405. Pipuy, f. 773.



1406. Psammethék, 649, 811.
Psammethék, later King
Psammetikhos III, 798.
Psammethék (others),
566, 613, 649, 670,
670, 719, 732, 740,
746, 771, 774, 796,
798, 802, 802, 803,
811, 813, 814, 814,
815, 816, 816, 817,
818, 820.
1407. Psammethék-aneit, 831.
Psammethék-a(u)neit
(various), 741, 772.
1408. Psammethék-emakhet
(various), 750, 798, 801.
1409. Psammethék-ib (?), 803.
Psammethék-ibsonb, *see*
Unnūfer.
1410. Psammethék-menempe,
803.
Psammethék-menkhib,
see Bekennanefu.
1411. Psammethék-meryneit,
799.
Psammethék-[meryneit],
see Pairkap.
1412. Psammethék-meryptaḥ,
798.
1413. Psammethék-nebpeḥti
(various), 566, 771.
Psammethék-nūfer, *see*
Pefteutau-amūn.
1414. Psammethék-sineit (vari-
ous), 772, 772, 800,
802, 867.
1415. Psammethék-siptaḥ, 771,
772.
1416. Psammethék-sirēc, 810.
1417. Psammethék-snefertauī,
801.
1418. Psammethék-sonb (vari-
ous), 772, 799, 813,
814, 814, 815, 867.
1419. Ptaḥ'aba, 818.
1420. Ptaḥ'ankhu (Iti), 682.
1421. Ptaḥardais (various), 573,
792, 796, 802, 810,
816, 823.
1422. Ptaḥemakhet (?), 808.
1423. Ptaḥemḥab (various),
668, 669.
1424. Ptaḥemḥēt (Ty), 571,
711.
1425. Ptaḥemḥēt (others), 540,
573.
1426. Ptaḥemma'et (?), 798.
1427. Ptaḥemma'kheru
(Esptaḥ), 803.
1428. Ptaḥemsaf, 748.
1429. Ptaḥemsas, f. 569.
1430. Ptaḥemwia, 751, 755.
Ptaḥemwia (others), 571,
770, 775.
1431. Ptaḥhotp [I], 596, 599,
608.
1432. Ptaḥhotp [II] (Thefi),
599, 599, 599, 599,
599, 600, 606.
Ptaḥhotp [III], 601.
1433. Ptaḥhotp (Ipti), 742.
1434. Ptaḥhotp (Iyni), 606.
1435. Ptaḥhotp (Lyni'ankh),
606.
Ptaḥhotp, 646, 646, 646.
Ptaḥhotp, 653, 653.
Ptaḥhotp, 805, 806.
Ptaḥhotp, 801, 867.
Ptaḥhotp (others), 419,
462, 581, 605, 605, 608,
653, 688, 731, 764, 788,
788, 791, 793, 796,
796, 798, 799, 800,
801, 802, 806, 806,
806, 808, 808, 809,
810, 811, 814, 814, 814,
814, 814, 814, 814,
814, 816.
Ptaḥhotp, *see* Thefu.
1436. Ptaḥhotp-desher, 462.
1437. Ptaḥhotp-wēr, 605.
1438. Ptaḥ-kha'c (various), 796,
806, 821, 845.
1439. Ptaḥma'kheru, 498.
1440. Ptaḥmay (various), 740,
745, 746, 859.
1441. Ptaḥmosi, HPM, 571,
712.
Ptaḥmosi, HPM, 712,
727.
Ptaḥmosi, Vizier, 721,
725.
Ptaḥmosi, Vizier, 773,
774.
Ptaḥmosi, 552, 552.
Ptaḥmosi, 667, 763.
Ptaḥmosi (others), 572,
572, 713, 728, 733, 759,
762, 770, 784, 834,
848, 861, 873.
1442. Ptaḥnaḳay (?), 817.
1443. Ptaḥnakht, 809.
1444. Ptaḥnemti, 735.
1445. Ptaḥnūfer (various), 754,
793, 809, 811.
1446. Ptaḥpuwah (Renef-
so(n)b), 879.
1447. Ptaḥsabu (various), 437,
646.
1448. Ptaḥ-sety, 572.
1449. Ptaḥshepses (Impy), 626,
627, 627.
1450. Ptaḥshepses [I], 499.
Ptaḥshepses [II], 460.
Ptaḥshepses (others), 393,
419, 457, 461, 461,
464, 464, 464, 480,
505, 518, 571, 582,
637, 645, 652, 652,
730, 732, 753, 769,
799, 821, 826.
Ptaḥshepses, *see* Sa'n-
khenptaḥ.
1451. Ptaḥuser (various), 456,
678.
1452. Ptaḥwenenef, 735.
1453. Ptaḥwēr, 796, 796.
Ptaḥwēr (others), 796,
809, 814, 814, 847,
859.
1454. Pueher, 807.
1455. Puerem, 806.
1456. Puḥu, f. 736.
1457. Puipeḥ (?) 859.
1458. Puy, f. 859.
1459. Ra'herka (Ipi), 679.
1460. Ra'hotp (various), 457,
480, 690, 879.
Ra'hotp, *see* Para'hotp.
1461. Ra'ia, 663.
1462. Ra'kher, f. 606.
1463. Ra'khuf, 634, 634.
Ra'khuf (others), 633,
634.
1464. Ra'meses-emperamūn,
817.
1465. Ra'meses-emperre'c
(Meryunu, Benithen),
715.
1466. Ra'mesesnakht, 761.
1467. Ra'meses-smakhaset, 865.
1468. Ra'meses-userkhepesḥ,
559.
1469. Ra'meses-sauemyunu,
859.
1470. Ra'meses-userpeḥti, 872.
1471. Ra'messu, 838, 872.
1472. Ra'mosi (various), 592,
667, 669, 669, 733,
808, 824, 833, 834,
849, 861.
Ra'mosi, *see* Amenmosi.
Ra'mosi, *see* Ḍhutmosi.
1473. Ra'neferere'ankh (various),
585, 698.
1474. Ra'nūfer, 461.
1475. Ra'res, f. 858.
1476. Ra'shepses, 485, 489, 494,
497.
Ra'shepses (others), 497,
723.
1477. Ra'wēr (various), 458,
558.
1478. Ra'y, 833.
1479. Rēc (various), 725, 833.
Rēc, f. 675.
Rēc, *see* Hori.
1480. Rebahī (Bahī?), 858.
1481. Rediptaḥka, 405.
1482. Reditnef (?), 405.
1483. Rediu, 676.

1484. Rē'emka, 487.
 1485. Rē'her tep (Iti), 546.
 1486. Re khsuptah, 787.
 1487. Re khti, f. 678.
 1488. Re khy, 687.
 1489. Re ky, 516, 516.
 1490. Rē'meryptah, 465.
 Renefso(n)b, *see* Ptaḥ-puwaḥ.
 1491. Renes'ankh (Ḥezert), f. 880.
 1492. Renes'ankh, 879.
 1493. Rennutet, f. 740.
 1494. Renpet, f. 812.
 1495. Renpet-'ankh, f. 651.
 1496. Renpetnefert, f. (various), 612, 697, 743, 743, 764, 766, 771, 801, 813, 816.
 Renpetnefert, *see* Taneit-iu (?)
 1497. Rerut, f. 687.
 1498. Rē'-set, 738.
 1499. Ressonb, 858.
 1500. Ria, f. 730.
 1501. Riri, 831.
 1502. Riuresti, f. 865.
 1503. Riya, 784, 784.
 1504. Roma (various), 838, 871.
 1505. Romy, 572.
 1506. Roy (various), 715, 844.
 Roy, f. 668.
 1507. Ruaben, 404, 437.
 1508. Rud, 433.
 1509. Ruiu, f. 737.
 1510. Ruz, 684.
 1511. Ruzi, 448.
 1512. Sab, 736. *See also* Sabu.
 1513. Sabnes, 548.
 1514. Sabu (Ibebi), 460.
 1515. Sabu (Thety), 463, 463.
 1516. Sabu (others), 443, 461, 546. *See also* Sab.
 1517. Sabu-kem, 463.
 1518. Saby, 570.
 1519. Saka, 748.
 1520. Sakeḥ, 761.
 1521. S'ankh (various), 861, 861.
 1522. S'ankhenptah (Ptaḥshepses), 698.
 1523. S'ankhenptah (others), 432, 672.
 1524. S'ankhnesi, 769.
 1525. S'ankhu-ḥathor, female dwarf, 761.
 1526. S'ankhuptah, 723.
 1527. Say, 571, 711.
 1528. Sayempeter, 559.
 1529. Sayempetref, 716.
 1530. Seba, 729, 871.
 Seba, 734.
 1531. Sebaḳu [II], 683.
 Sebaḳu [III], 683.
 1532. Sebarekhyt, f. 719.
 1533. Sebeky, 739.
 Sebeky, *see* Sebkemkhent.
 1534. Sebiu, f. 548.
 1535. Sebkemḥet (various), 886, 897.
 1536. Sebkemkhent (Sebeky), 610.
 1537. Sebkemkhent (others), 440, 778.
 1538. Sebkḥotp (Hepi), 568.
 1539. Sebkḥotp (Iri), 548.
 1540. Sebkḥotp (Petety), 880.
 1541. Sebkḥotp (others), 592, 685, 740, 865.
 1542. Sebkḥotp-ḥenku, 858.
 1543. Sebutet, f. 673.
 1544. Sedekh, 687.
 Sedekhi, f. 610.
 1545. Sedem'ash, 765.
 1546. Sefekhi, 546.
 1547. Sefekhptah (Neby), 424.
 1548. Sefekhu (various), 598, 604.
 1549. Sefget, f. 749.
 1550. Seḥefner, f. 436.
 1551. Seḥetepebrē'-ankh, 571.
 1552. Seḥotp, 740.
 1553. Seḥotpu, 541, 541.
 Seḥotpu, 439.
 1554. Sehy, 447.
 1555. Seḳed(?)kau, 724.
 1556. Sekhem'ankhptah (various), 454, 799.
 1557. Sekhemḥathor, f. 498.
 1558. Sekhemka, 456, 465.
 Sekhemka, 721, 730.
 Sekhemka (others), 543, 596, 721.
 1559. Sekhemka-sez, 445, 445, 445, 445.
 1560. Sekhemptah (Sekhemu), 571.
 1561. Sekhemrē', 753.
 Sekhemu, *see* Sekhem-ptah.
 1562. Sekhem-ubaste, 651.
 1563. Sekhentiu, 645.
 Sekhentiuka, *see* Iywen.
 1564. Sekhentiu-ptah (various), 568, 568.
 1565. Sekhentka, 756.
 1566. Sekhka, 447.
 1567. Sekhmet, f. 675.
 1568. Sekhmet-'ankhi (?), 548.
 1569. Sekhmetardais, f. 814.
 1570. Sekhmetka, 809.
 1571. Sekhmetnefert, f. 801, 803.
 Sekhmetnefert, f. (others), 771, 771, 784, 796, 813.
 1572. Sekwaskhet (various), 549, 549.
 1573. Sekwaskhet-'a, 549.
 1574. Sekwaskhet-ḥerib, 549.
 1575. Sekwaskhet-nekhen, 549.
 1576. Semdent, 520.
 1577. Semdet, f. 511.
 1578. Semenibsheps (?), 405.
 1579. Semertmin, f. 450.
 1580. Semsem, f. 812.
 1581. Semset, f. (various), 612, 844.
 1582. Semtu-tefnakht (various), 587, 801, 803, 803, 803, 803, 812, 861.
 1583. Semut, f. 548.
 1584. Sena' . . . (?), 548.
 1585. Senbeb, 571.
 1586. Senbebu, 885.
 1587. Senbebu (?), 885.
 1588. Senbef, 790, 794.
 Senbef (others), 786, 791, 795, 803, 803, 811, 814, 814, 829.
 1589. Senbet, f. 671.
 1590. Senbu, 604.
 1591. Senbuy, 738.
 1592. Seneb[ḥena's], f. 435.
 1593. Senebim, 565.
 1594. Senebrau, 571.
 1595. Senebsuma', 899.
 1596. Senebtifi, 889.
 1597. Senef'ankh, 542, 543.
 1598. Senen-dḥout, 734.
 1599. Senenu'ankh (various), 569, 582.
 1600. Seneny, 543.
 1601. Senezem (various), 546, 548.
 1602. Senezem . . . , 823.
 1603. Senezemib (Bebib), 451.
 1604. Senezemib (Bebibi), 565.
 1605. Senezemib (others), 463, 570, 756, 762.
 1606. Sengerka, 547.
 1607. Seni (various), 545, 568, 570, 681, 683, 688.
 Seni, f. (various), 568, 676.
 Seni, *see* Kai.
 Seni, *see* Neb(i)pu-pepy.
 Seni, *see* Shemi.
 1608. Senimen, 698.
 1609. Seniotef, 640, 641.
 1610. Senmut (?), 560.
 1611. Sent, f. 896.
 1612. Senti, 676.
 Senti, f. (various), 545, 681, 688.
 1613. Sentiotes, f. 568.
 1614. Sentni, f. 563.
 1615. Sent-senbetes, f. 883.
 1616. Senu, 557.
 1617. Senu'ankh, 898.

1618. Senusert (various), 552, 858.
 1619. Sepenmut, f. 879.
 Serbybyn, *see* Serbykhen.
 1620. Serbykhen (*or* Serbybyn) (Iby), 717.
 1621. Serefka (various), 548, 758.
 1622. Serma'et, 651.
 1623. Serseru, 764.
 1624. Sery, 874.
 1625. Seshemnūfer (Ḥeba), 595.
 1626. Seshemnūfer (Ifi), 614.
 1627. Seshemnūfer (others), 548, 619, 730, 891.
 1628. Seshemu, 492.
 1629. Seshemuka, 739.
 1630. Seshenu, 880.
 1631. Seshseshet (Idut), f. 617.
 1632. Seshseshet (Sheshti), f. 515.
 Seshseshet (Sheshti), f. 518.
 1633. Seshseshet, f. 394.
 Seshseshet, *see* Nebty-nubkhet.
 Seshseshet, *see* Wātet-khet-ḥor.
 1634. Seshu, 768.
 1635. Sesi, 689.
 Sesi, f. 568, 570.
 Sesi, *see* 'Ankhma'ḥor.
 1636. Setau, 860.
 1637. Setemḥab, 413.
 1638. Sethef, 724.
 1639. Sethes-ptah, 758, 758.
 1640. Sethet, f. (various), 610, 612, 612.
 1641. Sethet-iteru, f. 546.
 1642. Set-ḥirwenemef, 559.
 1643. Sethu [I], 449.
 Sethu [II], 490.
 Sethu (others), 538, 577, 698, 898.
 Sethu, *see* Pepy'ankh.
 1644. Sethy, 676.
 1645. Setibti (Bebi), f. 688.
 1646. Setka, 403.
 Setka, 446, 446.
 1647. Sety (various), 667, 675, 821.
 1648. Setyerboni, f. (various), 649, 650, 765, 798, 801, 802, 802, 802, 811.
 1649. Setyersebu, f. 774.
 1650. Shabt, f. 735.
 1651. Shafef, 548.
 1652. Shedabd (various), 566, 689.
 1653. Shededu-snefru, 570.
 1654. Shedi, 700.
 Shednefertem, *see* Zeḥo.
 1655. Shedsuḥori, 849.
 1656. Shedsunefertem, HPM, 760, 786, 823, 841, 842, 866, 872.
 Shedsunefertem, 800, 802.
 Shedsunefertem (others), 796, 796, 809, 810, 812, 814, 850, 858.
 Shedu, *see* Shedy-ptah.
 1657. Shedy, f. 549.
 1658. Shedy-ptah (Shedu), 545.
 1659. Shedy-ptah, 548.
 1660. Shekert, f. 676.
 1661. Shema (various), 558, 558, 687.
 1662. Shemai (various), 564, 673, 684.
 1663. Shemait, f. 682.
 1664. Shemi (Seni), 571.
 1665. Shemrebi, f. 862.
 1666. Shemsetka, f. 769.
 1667. Shena'y, 678, 742.
 1668. Shepenēsi, f. 765.
 1669. Shep(en)-ius'as, 812.
 1670. Shepenius'aset, 752.
 1671. Shepensopdet, f. 800, 802.
 1672. Shepenubaste, f. (various), 587, 813, 814.
 1673. Shepenwept I or II, f. 831.
 1674. Shepeskau, 698.
 1675. Shepi (Thety), 741.
 1676. Shepses, 698.
 1677. Shepseskaf'ankh, 759.
 1678. Shepsetkau, f. 761.
 1679. Shepsi, 457, 458.
 Shepsi (others), 443, 482.
 1680. Shepsipuptah, 608.
 1681. Shepsipuzad (Shepsipuzad-nezes), 457, 458.
 Shepsipuzad-nezes, *see* Shepsipuzad.
 1682. Shepy, 892, 893.
 1683. Shery, 490.
 1684. Shesepamūn-tefḥert (various), 794, 801.
 1685. Shesethef, 823.
 1686. Sheshi (various), 506, 676.
 Sheshi, *see* Neferse-shemrē.
 Sheshi, *see* Uzaḥateti.
 1687. Sheshonḳ, 722, 785, 846, 847, 875.
 Sheshonḳ, 806.
 Sheshti, *see* Seshseshet.
 1688. Shey, 682.
 1689. Si, 734.
 1690. Siaḥor, 548.
 1691. Siamūn, 747, 874.
 1692. Siatum, 706.
 1693. Si[en]unis, 570.
 Sienuinis, 625, 625.
 1694. Siēsi (various), 721, 816, 898.
 1695. Si-ḥathor (Ipi), 701.
 1696. Si-ḥathor (others), 878, 879.
 1697. Si-ipy (various), 735, 885.
 1698. Simery (various), 633, 734.
 1699. Sineb'ankh, 803.
 1700. Sinūhet, 811.
 1701. Sip, 563.
 1702. Sipair, 732.
 1703. Siptah, 809, 809.
 Siptah, 810.
 1704. Sitamūn, f. (various), 740, 880.
 1705. Sitenkauptah, f. 429.
 1706. Sit-gemni, f. (various), 539, 545.
 1707. Sitha'ib, f. 517.
 1708. Sit-ḥap, f. (various), 562, 811, 811, 812.
 1709. Sit-ḥap'ankh, f. 814.
 1710. Sit-ḥathor, f. (various), 429, 429, 569, 745, 878, 879, 883, 896, 896, 896.
 1711. Sit-ḥat(ḥor)-mer(t), f. 886.
 1712. Sitiker, f. 543.
 1713. Sit-impy, f. (various), 564, 569.
 Sitin, *see* Sitinteti.
 1714. Sitinteti (Sitin), f. 539, 540.
 1715. Siti'oh, f. 829.
 1716. Sitip, f. (various), 652, 874.
 1717. Sit-iythenu, f. 568.
 1718. Sit-khemt *or* Sit-khemt-(nu), f. (various), 545, 546, 563, 766.
 1719. Sitmert, f. (various), 723, 730, 770.
 1720. Sitmeseh, f. 880.
 1721. Sitmut, f. 725.
 1722. Sitnetpepy, f. 749.
 1723. Sitpep, f. 797.
 1724. Sitsen, f. 736.
 1725. Sit-shedabd, f. (various), 567, 570.
 1726. Sit-shenzet, f. 551.
 1727. Sitsobk, f. (various), 563, 899.
 1728. Sitti, f. 557.
 1729. Situbastet, f. 673.
 1730. Sit-wernu, f. (various), 538, 547, 778.
 1731. Sitwerut, f. 886.
 1732. Smagery (?), f. 775.
 1733. Smaḥetepkhnun, 402.
 1734. Smataui, 765.
 1735. Smenkhuptah (Itwesh), 452.









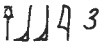

1736. Smenkhuṭṭah, 422.
 1737. Smentau, 784.
 1738. Snefru (various), 687, 880, 880.
 Snefru, *see* . . . rer.
 1739. Snefruemṣasi, f. 878.
 1740. Snefru-ḥirkhent, 879.
 1741. Snefruḥotp (various), 622, 879.
 1742. Snefrunūfer [I], 468, 468.
 Snefrunūfer [II], 468, 468.
 1743. Snefrusonb, 724.
 Snefru(sonb), 881.
 1744. Snefrusonb-nezes, 881.
 1745. Snefru . . . (Hetep), 898.
 1746. Sobki, 546.
 1747. Sonb (various), 724, 769, 887.
 1748. Sopdetiyt *or* Sopdetiyti, f. (various), 799, 803.
 1749. Sopduḥotp, 481, 481.
 1750. Suemʿankhef, 860.
 1751. Sunero, 412.
 1752. Suti, 737.
1753. Taʿa, f. 587.
 1754. Ta-amūn-neb, f. 573.
 1755. Taʿarḥapy, f. 593.
 1756. Taʿarwoz, f. 767.
 1757. Taʿashakhet, f. 847.
 1758. Taʿaty, f. 737.
 1759. Tabaʿanep, f. 612.
 1760. Tabes, f. (various), 800, 827.
 1761. Tade, f. 794.
 1762. Tadeamūn-paiot, f. 573.
 1763. Tadeimḥōtep, f. (various), 651, 825.
 1764. Tademehent, f. 771.
 1765. Tademehyt, f. 822.
 1766. Tadeneb(t)hen, f. 788.
 1767. Tadenubhotp, f. 772.
 1768. Tadeparēʿ, f. 793.
 1769. Tadeptaḥ, f. 651.
 1770. Tadēsi, f. 802.
 1771. Tadesmazedeb (?), f. 557.
 1772. Tadeusiri (Tentusiri), f. 765.
 1773. Tadeusiri, f. (others), 505, 505, 747, 771, 815.
 1774. Tade . . ., f. 573.
 1775. Tadḥout, f. 748.
 1776. Tageb, f. 588.
 1777. Tagemirēsi, f. (various), 649, 867.
 1778. Tahaib (?), f. 816.
 1779. Taḥarpekḥrod-sekḥmet, f. 573.
 1780. Taherib, f. 831.
 1781. Taḥert, f. 811.
 1782. Taḥesy, f. 552.
 1783. Taḥetre, f. 738.
 1784. Taḥyb, f. 872.
1785. Tai (?), 650, 651.
 1786. Taiḥet-ʿankhti, f. 651.
 1787. Taimḥōtep, f. 744, 744.
 Taimḥōtep, f. (others), 744, 744, 885.
 1788. Tairi-sherit, f. 818.
 1789. Tairterau, f. 804.
 1790. Takap, f. (various), 801, 802, 802.
 1791. Takapenkhebi, f. 799.
 1792. Takapu, f. 803.
 1793. Takʿas, f. 505 (*as* Teḥʿan), 765 (*same object quoted twice*).
 1794. Takernerfer(t), f. 823.
 1795. Takertia, f. 857.
 1796. Takḥaʿ, f. 675.
 1797. Takḥar, f. (various), 675, 792.
 1798. Takḥaʿt, f. 701, 702.
 Takḥaʿt, f. 745.
 1799. Takḥer (or Kheter), f. 507.
 1800. Takhet, f. 823.
 1801. Takhit, f. 573.
 1802. Takḥuti, f. 720.
 1803. Takḥyay, f. 815.
 1804. (T)amen, f. 746.
 1805. Tamert, f. 744.
 1806. Tamyt, f. 669.
 1807. Tanebteḥ, f. 764.
 1808. Taneferḥeret, f. 766.
 1809. Taneferḥo, f. 744.
 1810. Tanefertem, f. 815.
 1811. Tanefertiti, f. (various), 573, 648.
 1812. Taneitiu (?) (Renpetnefert), 612.
 1813. Tanennūter, f. 506.
 1814. Tanenuny, f. 855.
 1815. Tanubenwaskhet, f. 765.
 1816. Tapakhentet, f. 744.
 1817. Taped, f. 806.
 1818. Tapert, f. 770, 771.
 Tapert, f. 866.
 1819. Tared, f. 746.
 1820. Taremtenubaste, f. (various), 764, 766, 803.
 1821. Tarepet, f. 767.
 1822. Tares, f. 648.
 1823. Taruy, f. 787.
 1824. Tasenḥor, f. 798.
 1825. Tasent(ent)ḥor, f. 588.
 1826. Tashenēsi (various), f. 566, 649.
 1827. Tashenpashai, f. 800.
 1828. Tashensekḥmet, f. 811.
 1829. Tashen(n)tekert, f. 591.
 1830. Tashentiḥet, f. (various), 651, 765, 800, 817.
 1831. Tashentnehy, f. 824.
 1832. Tashepenēsi, f. 866.
 1833. Tasmataui, f. 765.
 1834. Tasokari, f. 801.
1835. Tata, f. 795.
 1836. Tathenef, f. 814.
 1837. Tathet, f. 736.
 1838. Tausert, f. 858.
 1839. Tawah, f. 669.
 1840. Tawer(t), f. 734.
 1841. Tawertemḥab, f. 861.
 1842. Tawer(t)-ḥetepti, f. 737.
 1843. Tawi, f. 712.
 1844. Tawonshet (Tentḥap), f. 504.
 1845. Taya, 770.
 1846. Tayirterau, f. 803.
 1847. Taysiry, f. 733.
 1848. Tefnakht, 507.
 1849. Tefnut, f. (various), 504, 767, 772.
 1850. Teḥent, f. 507.
 1851. Teḥenuka, f. 442.
 Teḥʿan (?), *see* Takʿas.
 1852. Temʿa, f. 896.
 1853. Tena, 773.
 1854. Tenro, 848.
 1855. Tenry, 666, 742.
 1856. Tent, f. 816.
 1857. Tentamentet, f. 559.
 1858. Tentamūn, f. (various), 503, 763.
 1859. Te(n)tḥap, f. 813.
 Tentḥap, *see* Tawonshet.
 1860. Ten-tho, f. 805.
 1861. Tent-ḥor, f. 767.
 1862. Tentiuun, f. 834.
 1863. Tentkem, f. 507.
 1864. Tent-kheta, f. 798.
 1865. Tentnamenesh, f. 859.
 1866. Tentnefertem, f. (various), 788, 802.
 1867. Te(n)tubaste, f. 817.
 Tentusiri, *see* Tadeusiri.
 1868. Tepemʿankh [I], 483.
 Tepemʿankh [II], 483.
 Tepemʿankh, 698.
 Tepemkau, *see* Idi.
 1869. Tepemnefert, f. 693.
 Tepes, *see* Neferḥōtep-ḥaḥor.
 Tepka, *see* Ḥetepka.
 1870. Ter, 572.
 1871. Teri, f. 741.
 1872. Teru, f. 651.
 1873. Teskapu, f. 771.
 1874. Tesnakht, f. (various), 767, 800.
 1875. Tet, 436.
 1876. Teti (*possibly same man in all cases*), 503, 503, 503, 503.
 Teti (others), 684, 736, 742, 773, 858, 865.
 Teti, *see* Tetiemsaf.
 1877. Tetiʿankh (various), 520, 676.
 1878. Tetiemsaf (Teti), 394.

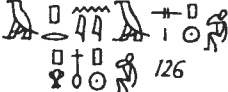
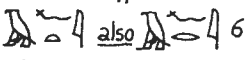

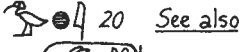

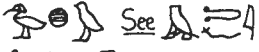

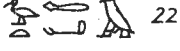
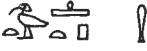



- Tetiemsaf (others), 545, 564, 570.
1879. Teti-ḥaishtef (various), 548, 563.
1880. Teti-ḥarsiēsi (?), f. 763.
1881. Teti-ḥirmaa-neferuptaḥ, 538.
1882. Teti-ḥirmenkhet, 563.
Tetisonb, *see* Meru.
1883. Tetizedi (Pepyzedi, Zedi), 509, 509, 509.
1884. Teti . . ., 568.
1885. Tety, 440.
1886. Teye, f. 689.
1887. Tha, 562.
1888. Tha-amenemwēset, 807.
1889. Thaenab, 866.
1890. Thaenḥab, f. 770.
1891. Thaenkhonsenimu, 807.
1892. Thaenmu, 825.
1893. Thai, 538.
1894. Thaia, 784.
1895. Thaibanebdedetimu, 720.
1896. Thaienhorimu (various), 503, 748.
1897. Thaiēsenimu, 771, 773.
1898. Thaiēsimu, 831, 874.
1899. Thaiharimu, 799.
1900. Thaiḥarpata, 504, 504.
1901. Thaiḥepimu, father of Nektanebos II, 503, 854.
Thaiḥepimu (others), 503, 734, 812, 814, 814, 823, 872.
1902. Thai-inḥertimu, 507.
1903. Thai-pautitai-imu, f. 831.
1904. Thaiubastimu, f. 763.
1905. Thanenhebu, 648.
1906. Tharet, f. 740.
1907. Thau, 699.
1908. Thauineb-ḥezet, f. 562.
1909. Thay (To), 784.
Thay (others), 412, 414, 507, 553, 726.
Thefi, *see* Ptaḥhotp [II].
1910. Thefu (Ptaḥhotp), 605.
1911. Thefu (others), 598, 608.
1912. Thekerti, 786, 847, 847, 847, 873.
1913. Thekhet, f. 798.
Them, *see* Khenu [II].
1914. Themru, 513, 513.
1915. Thenenet, f. 542.
1916. Thentet, f. (various), 608, 690, 739.
1917. Thenteti, f. (various), 451, 501, 768.
1918. Thenti (various), 482, 482, 640, 730, 762, 768, 895.
1919. Therut, f. 764.
1920. These mu, 606.
1921. Thesenptah, 827.
1922. Thesēsi-erboni (?), f. 802.
1923. Theset (Mestni), f. 563.
1924. Theset, f. (various), 608, 630, 643, 827.
1925. Thes-ḥap-pert, f. (various), 735, 792.
1926. Theskhenspert, f. 822.
1927. Thesmutpert, f. 831.
1928. Thesubastepert, f. 786, 847.
Thesubastepert, f. 813.
1929. Theteti (various), 511, 566.
1930. Thetety, 675.
1931. Thethi, 447.
Thethi, *see* Ishethi.
Thethi, *see* Neferkhuu-ptah.
1932. Theti, f. 686.
1933. Thethu, 537.
1934. Thetui, 600, 608.
1935. Thetut, 519.
Thety, *see* Sabu.
Thety, *see* Shepi.
1936. Thonüfer (various), 787, 789, 791, 816.
1937. Thuiay, f. 749.
1938. Thuthu (various), 742, 820.
1939. Thuthuia, f. 702.
1940. Ti, f. 627.
1941. Tia, 654, 740.
Tia, f. (various), 654, 821.
1942. Tiamün, f. (various), 505, 748, 812, 817.
1943. Tipuy, f. 709.
Tit, *see* Nezetempet.
1944. To (various), 861, 875.
To, *see* Thay.
1945. Tusu, 675.
Tutu, *see* Ishefi.
1946. Tutu-imḥōtep, 813.
1947. Tuy, f. (various), 557, 654.
1948. Ty, 468, 729.
Ty, 469, 471.
Ty (others), 450, 506, 758.
Ty, f. (various), 668, 730, 759.
Ty, *see* Ptaḥemḥēt.
1949. Tyerneḥē, 860.
1950. Ubastear dais, f. (various), 565, 591.
1951. Ubasteiyti, f. 738.
1952. Unis-akhi (Akhi), 652.
1953. Unis-ankh (various), 616, 695.
1954. Unisemsaf, 652.
1955. Unis-ergesptah, 652.
1956. Unis-ḥaishtef (Ḥaishtef), 615.
1957. Unnūfer (Psammethek-ibsonb), 815.
1958. Unnūfer, 503, 760.
Unnūfer (others), 612, 612, 764, 812, 812, 813, 814, 815, 816, 820, 823, 849.
1959. User (various), 545, 613.
1960. Userḥēt, 395.
1961. Userken (various), 794, 869.
1962. Usermut (various), 545, 549, 570.
1963. Userpeḥtinesu (?) (Iy-ḥadru?), 735.
1964. Usertkau, f. 721.
1965. Usirinakht (various), 795, 807, 866.
1966. Uza, f. 612.
1967. Uzaḥateti (Neferseshem-ptah, Sheshi), 515.
1968. Uzaḥor (various), 503, 793, 796, 796, 807, 807, 810, 811, 815, 827.
1969. Uzaḥor-khat (?), 872.
1970. Uzaḥor-meḥent, 797.
1971. Uzaḥorresnet (Neferebrēc-*ne*bpeḥti), 838.
1972. Uzaḥorresnet, 800, 802.
Uzaḥorresnet, 844, 867.
Uzaḥorresnet (others), 719, 771, 794, 810, 812, 813.
1973. Uzai, 548.
1974. Uzakhons, 746.
1975. Uzarenu (?), 807.
1976. Uzat-khnementi (?), 679.
1977. Uzau, 892.
1978. Waḥ, 564.
1979. Waḥ, 412.
1980. Waḥka, 835.
1981. Washiptah, 680.
1982. Washka (various), 465, 465.
1983. Washptah (Isi), 456.
1984. Washptah (others), 541, 824.
1985. Waḥt, 641.
1986. Waḥten, f. 745.
1987. Waḥtetkhet-ḥor (Seshshet), f. 525, 534.
1988. Watnefert, f. 448.
1989. Wazet, f. 683.
1990. Wazet-ipi, 569.
1991. Wazetiyyt, f. 764.
1992. Wazkaus, f. 626.
1993. Waznes, 446.
1994. Waztifni, 403.
1995. Webekhnesiḥōḥ (*probably better*: Webennesiḥōḥ), 773.

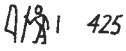

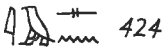







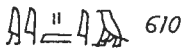
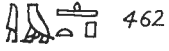
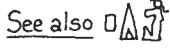

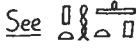
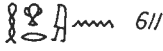

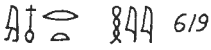





- Webennesi'oh, *see* Webe-
 khnesi'oh.
 1996. Weḥa', 440.
 1997. Weḥebrē' (Amentef-
 nakht), 815.
 1998. Weḥebrē' (others), 752,
 767, 773, 794, 844.
 Weḥebrē', *see* 'Ankh-ḥor.
 Weḥebrē', *see* Pedubaste.
 Weḥebrē'-emakhet, *see*
 Ḥor.
 1999. Weḥebrē'-emkhebi (vari-
 ous), 801, 813.
 2000. Weḥebrē'-ḥarenpe (vari-
 ous), 811, 824.
 2001. Weḥebrē'-men, 587.
 2002. Weḥebrē'-mererptaḥ,
 810.
 Weḥebrē'-merneit, *see*
 Weḥebrē'-meryneit.
 2003. Weḥebrē'-meryneit
 (various), 764, 804, 812.
 2004. Weḥebrē'-mer(y)ptaḥ
 (various), 798, 811, 812,
 811, 812.
 2005. Weḥebrē'-nebḳen (vari-
 ous), 741, 831.
 2006. Weḥebrē'-nebpeḥti, 812.
 2007. Weḥebrē'-unnūfer (vari-
 ous), 799, 811.
 2008. Weḥebrē' . . . (various),
 811, 813.
 2009. Weḥemnefert, f. 479.
 2010. Wemtet[ka], f. 878.
 2011. Wen, f. 564.
 2012. Wenamūn, 787.
 2013. Wendes-ḥes, f. 798.
 2014. Wenefzedsen, 573.
 2015. Wenemdi-amūn, 806.
 2016. Weneni, 679.
 2017. Wenent, 849.
 2018. Wenḥerpe (?), 651.
 2019. Weni (various), 427, 506.
 2020. Wenptaḥ, 810.
 2021. Weny-impy (?), 563.
 2022. Wepeti, f. 563.
 2023. Wepka, 506.
 2024. Wepti, 683.
 2025. Weput, f. 568.
 2026. Wepwautmosi, 734.
 2027. Weramūn, 819.
 2028. Werbau, 640, 641.
 2029. Werbauptaḥ, 858.
 2030. Werek, f. 800.
 2031. Werekh, 547.
 2032. Weret, f. 661, 661.
 2033. Weriai, f. 562.
 2034. Werinni, 478.
 2035. Werirniptaḥ, 699.
 2036. Werkai (various), 568,
 571.
 2037. Werkaptaḥ (various), 491,
 735.
 2038. Werkauptaḥ, 584.
 2039. Werkherp-ḥemut, 858.
 2040. Wernu, 519.
 2041. Wernuro, f. (various),
 665, 732.
 2042. Wershūfer, 504.
 2042A. Wertka, f. 736.
 2043. Wert-khenreti, f. 729,
 871.
 2044. Werzedptaḥ, 541.
 2045. Wesa, 427.
 2046. Wesenptaḥ (?), f. 895.
 2047. Wesi, 718.
 2048. Wethesetkaus, f. 583.
 2049. Wethesu-khet (?), f. 548.
 2050. Wetka, 692, 693.
 2051. Wezebten, f. 432.
 2052. Wezmut'ankhes, f. 788.
 2053. Wiay, f. 667.
 2054. Yewerhen, 858.
 2055. Yipu (various), 745, 752.
 2056. Yua, 746.
 2057. Yuhebet, f. 784.
 2058. Yunmin (various), 506,
 546.
 2059. Yunut, 675, 675.
 2060. Yupa'a, 715.
 2061. Yuyu (various), 728, 730.
 2062. Yy, 784.
 2063. Za'a'ti, 609.
 2064. Zadi, 676.
 Zadi, *see* Pepyzedi.
 Zadi, *see also* Zedi.
 2065. Zadptaḥ, 823.
 2066. Zadshepses, 762.
 2067. Zauemnakht, 429.
 2068. Zay, 758.
 Zazam'ankh, *see* Tepem-
 'ankh.
 2069. Zeamūnef'ankh (various),
 557, 749, 767, 794,
 794, 796, 796, 810,
 815, 822.
 Zedi, *see* Tetizedi.
 Zedi, *see also* Zadi.
 2070. Ze-ēsef'ankh (various),
 613, 815.
 2071. Zefanesut, 700.
 2072. Zefates, f. 676.
 2073. Zefatsen, f. 482, 491.
 2074. Zefau, 466.
 2075. Zeharef'ankh, 800.
 2076. Zeḥo (Neb'ankh), 817.
 2077. Zeḥo (Shednefertem),
 804.
 2078. Zeḥo, 505, 765 (*same*
object).
 Zeḥo (others), 507, 613,
 651, 651, 741, 748,
 764, 765, 766, 796,
 796, 803, 814, 815,
 815, 824.
 Zeḥo, *see* Pawenḥētef.
 2079. Zeiuenptaḥ, 798.
 2080. Zekhensef'ankh, 796.
 2081. Zeptaḥef'ankh (various),
 760, 786, 787, 787,
 789, 789, 791, 793,
 793, 796, 796, 796,
 801, 801, 803, 807, 811,
 811, 816, 854, 859, 867.
 2082. Zeubastef'ankh, 804, 811.
 2083. Zeubastes'ankh, f. (vari-
 ous), 817, 867, 873.
 2084. Zewertes'ankh, f. 770.
 2085. . . . amūn, 809.
 2086. . . . beḥēsi . . . , 817.
 2087. . . . denebwen, 796.
 . . . ḥap, *see* Ir'ahor.
 2088. . . . ḥotp (various), 568,
 801, 849.
 2089. . . . iau, 807.
 2090. . . . ibnub, f. 535.
 2091. . . . menkaurē' . . . , f. 632.
 2092. . . . meryrē', 572.
 2093. . . . mosi, 770.
 2094. . . . nakht, 791.
 2095. . . . neferebrē', 775.
 2096. . . . rer (Snefru), 879.
 2097. . . . ruu, 547.
 2098. . . . wep'au (Pefteu'au-
 baste), 801.
 2099. . . . y, 759.
 2100. , 682.
 2101. , 769.

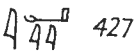
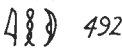

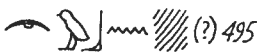

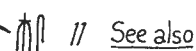

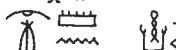
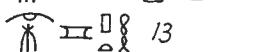
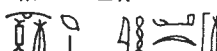



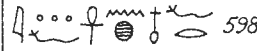
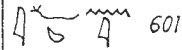

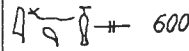





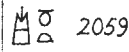

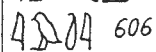

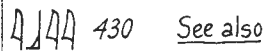
II. Hieroglyphic forms.

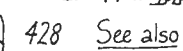

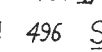

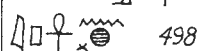

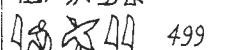
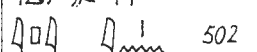
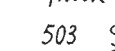

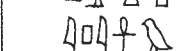
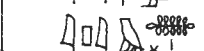



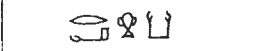
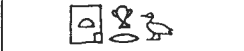

Only one form given. Numbers refer to Section I

 1
 2
 3
 5
 126
 also  6
 19
 20 See also 
 See 
 22
 404 24
 25
 23
 26
 18
 16

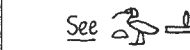



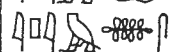

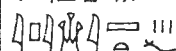
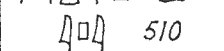



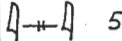











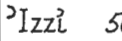

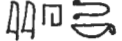









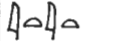

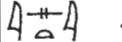

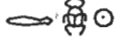



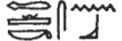
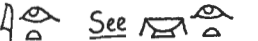

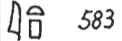



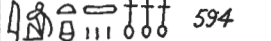

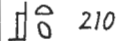



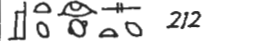

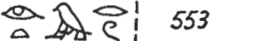

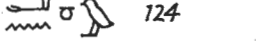









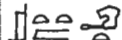

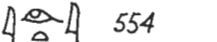
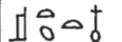



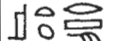













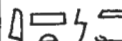



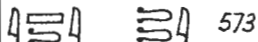
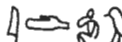







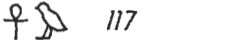
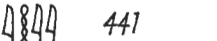

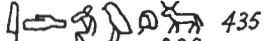



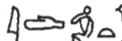



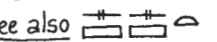
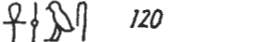

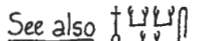

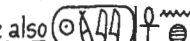
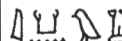

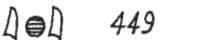
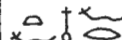

 420
 426
 425
 423
 424
 613
 See 
 625
 626

 610
 462
 See also 
 618
 617
 See 
 611
 622
 623
 619
 620
 621
 614
 615
 616
 627
 421
 427
 492
 493
 (?) 495
 494
 See also 
 12
 13
 14
 15
 422
 596

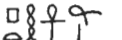
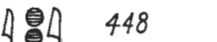
 597
 598
 601
 599
 600
 602
 608
 607
 603
 2058
 2059
 605
 604
 606
 429
 430 See also 
 428 See also 
 496 See also 
 498
 497
 499
 502
 503 See also 
 519
 520
 525



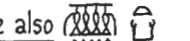



















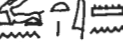



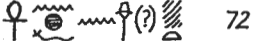
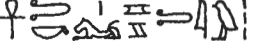
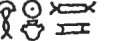
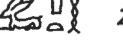

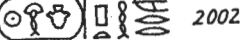
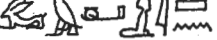



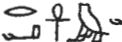

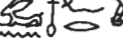
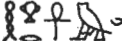

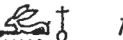



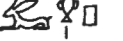
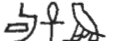
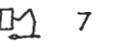
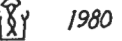
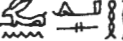



























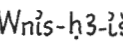



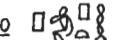

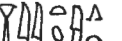
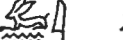
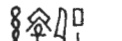

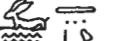









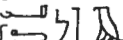
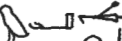





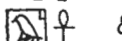
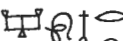



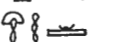
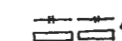
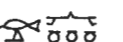

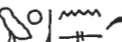

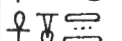



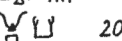
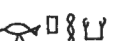

 504
 505
 See 
 507
 508
 509
 510
 511
 512
 513
 514
 515
 527
 516
 519
 520
 525

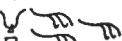
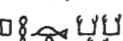
| | | | |
|-------------|------|----------------|--------------|
| 521 | 465 | 56 | 480 |
| 526 | 466 | 57 | 481 |
| 522 | 45 | See also | 482 |
| 523 | 29 | 47 | 483 |
| 524 | 30 | 59 | 484 |
| 517 | 46 | 61 | 476 |
| 501 | 58 | Imny-w3h-ib 62 | 528 |
| 518 | 37 | 60 | 529 |
| See also | 38 | 461 | 531 |
| 500 | 39 | 467 | 532 |
| See | 36 | 472 | 533 |
| 437 | 41 | See | 530 |
| | 33 | | See also |
| See | 34 | 473 | 535 |
| 453 | 35 | 123 | 534 |
| | | 478 | 536 |
| 456 | 31 | 477 | 540 |
| | 32 | 485 | 541 |
| 457 | 40 | See | 538 |
| See also | 49 | | 537 |
| | | 488 | See also |
| 455 | 51 | 489 | 542 |
| 458 | 50 | 486 | 539 |
| 459 | 52 | 487 | 549 |
| = 470 | 53 | See | 544 |
| = 44(?) 471 | = 54 | 490 | 545 |
| = 454 | 42 | 491 | 548 |
| 859 | = 44 | See | 546 See also |
| 468 | 43 | 474 | |
| 469 | 44 | 475 | 547 |
| = 460 | 48 | 475 | 564 See also |
| = 44 | 55 | See | |
| 463 | | 479 | |
| = 44 464 | | | |
| See also | | | |

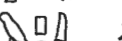

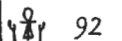

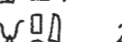











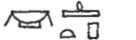

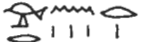





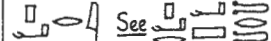
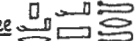

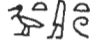
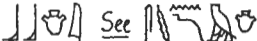

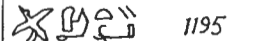



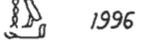





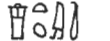

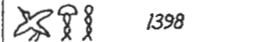





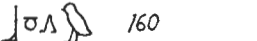

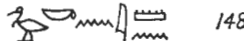



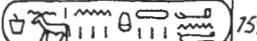

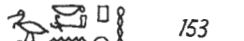

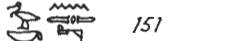
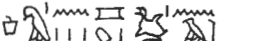



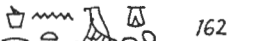

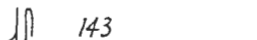



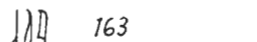

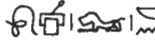

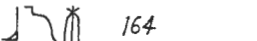
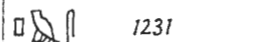
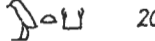
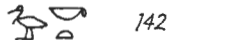

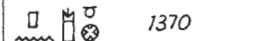





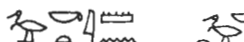

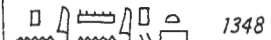





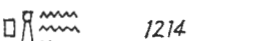

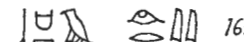
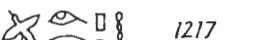
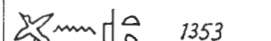





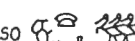



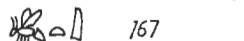

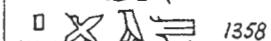

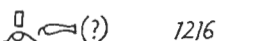
| | | | |
|---|---|--|---|
|  565 |  575 |  590 <u>See also</u> |  2054 |
|  560 | <u>See also</u>  |  |  2057 |
|  561 |  577 |  |  2055 |
|  562 | ² Izzi  567 |  593 |  612 |
|  563 |  568 |  591 | |
|  <u>See</u>  |  569 |  * 595 |  4 |
|  129 |  570 |  592 |  63 |
|  550 |  579 |  |  17 |
|  543 |  576 | <u>See</u>  |  27 |
|  <u>See</u>  |  566 |  583 <u>See Addenda below</u> |  137 |
|  557 |  578 |  594 |  127 |
|  555 |  210 |  582 |  125 |
|  556 |  212 |  584 |  124 |
|  553 |  211 |  585 |  64 |
|  558 |  220 |  586 |  65 |
|  551 |  214 | <u>See also</u>  |  66 |
|  552 |  213 |  588 |  86 |
|  554 |  215 |  587 |  87 |
|  |  217 |  431 |  88 |
| <u>See</u>  |  571 | <u>See also</u>  |  90 |
|  559 |  572 |  432 |  89 <u>See also</u>  |
|  <u>See</u>  |  574 |  436 |  91 |
|  440 |  573 |  433 |  113 |
|  439 |  446 | <u>See also</u>  |  117 |
|  438 |  447 |  |  119 |
|  441 |  450 |  435 |  118 |
| <u>See also</u>  |  451 |  434 |  120 |
|  442 |  452 | <u>See also</u>  |  706 |
|  444 | <u>See also</u>  |  609 |  107 |
| <u>See also</u>  |  445 |  2062 |  108 |
|  443 |  580 |  624 |  109 |
|  449 |  581 |  2061 |  67 |
|  448 |  |  2056 |  73 |
| <u>See also</u>  |  589 |  2060 | |

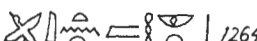

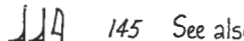



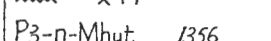

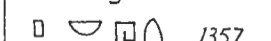
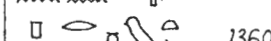

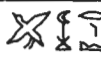
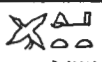

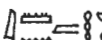
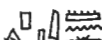



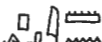

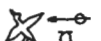



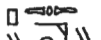





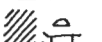



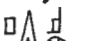
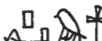















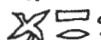







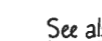

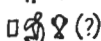
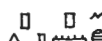







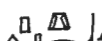

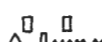



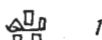



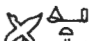

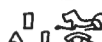
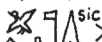

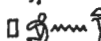
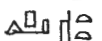



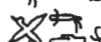
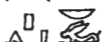



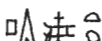



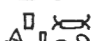





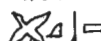
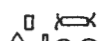

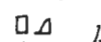
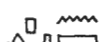
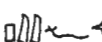

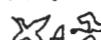

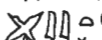

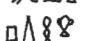
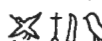
Addenda:  135











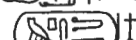
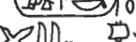
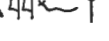



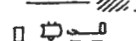
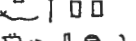
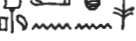

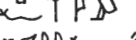
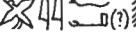

 136

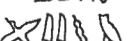
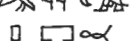
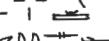
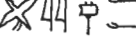

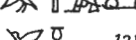

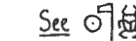

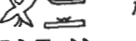





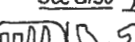

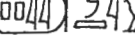
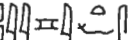
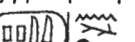







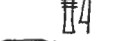

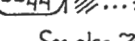
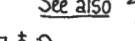

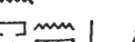
| | | | |
|--|--|---|---|
|  69 |  93 |  See  |  2011 |
|  70 |  94 |  1999 |  2019 |
|  68 |  78 |  2001 |  2012 |
|  71 |  114 |  2004 |  2014 |
|  72 |  115 |  2003 |  2020 |
|  96 |  116 |  2002 |  2015 |
|  99 |  121 |  2006 | |
|  100 |  122 |  2005 |  1957 |
|  97 |  128 |  2000 |  1958 |
|  98 |  7 |  2008 |  2018 |
|  74 |  7A |  1980 |  2013 |
|  101 |  8 |  1983 |  2021 |
|  75 |  9 |  1984 |  1952 |
|  102 |  10 |  1981 |  1953 |
|  103 |  21 |  1982 |  1954 |
|  105 |  132 |  1994 |  1955 |
|  104 |  130 |  1993 |  1955 |
|  82 |  134 |  1992 |  Wnīs-h3-īst-f |
|  79 |  131 |  1989 |  1956 |
| See also  |  133 |  1991 |  2016 |
|  80 |  28 |  1990 |  2017 |
|  84 |  139 |  2053 |  2027 |
|  85 |  138 |  1978 |  2034 |
| See also  |  1988 |  1985 |  2035 |
|  81 |  1979 |  1986 |  2028 |
|  83 |  1997 |  1987 |  2029 |
|  95 |  1998 |  1995 |  2040 |
|  112 |  1999 |  2026 |  2039 |
|  110 |  1997 |  2023 |  2036 |
|  76 |  1998 |  2025 |  2037 |
|  77 |  2007 |  2024 |  2038 |
|  111 |  2007 |  2022 |  2044 |
|  92 |  2007 |  2010 |  2032 |

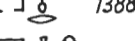
𐎎𐎗 2042 A

| | | | |
|---|---|---|--|
|  2043 |  1973 |  |  1198 |
|  2033 |  1977 |  |  |
|  2041 |  1976 |  | 1246 |
|  2031 |  2051 |  See  |  See  |
|  2042 |  140 |  See  |  1195 |
|  2030 |  144 |  146 |  1194 |
|  1996 |  See  |  161 |  1199 |
|  2009 |  1951 |  See  |  1398 |
|  2046 |  1950 |  160 |  1266 |
|  2045 |  147 |  160 |  |
|  2047 |  148 |  158 | 1267 |
|  1965 |  149 |  759 |  1268 |
|  1959 |  153 | Bnt-n-dw3-ntr 166 |  1269 |
|  1963 |  151 |  See  |  1270 |
|  1962 |  152 |  162 |  1200 |
| Wsr-h3t 1960 |  154 |  143 |  1346 |
|  1964 |  155 |  163 |  1230 |
|  1961 |  150 |  164 |  1231 |
|  2050 |  142 |  1196 |  1370 |
|  2049 | See also  |  1219 |  1350 |
|  2048 |  156 |  1401 |  1348 |
|  2052 |  157 |  1214 |  1349 |
|  1966 |  141 |  1217 |  1353 |
|  1975 |  165 |  1218 |  1347 |
|  1967 |  168 |  1215 |  1369 |
|  1968 | See also  |  1216 |  1358 |
|  1970 |  167 |  1264 |  1359 |
| Wd3-Hr-rsnt |  169 |  1192 |  1355 |
| Nfr-ib-Rc-nb-phty 1971 |  169A |  1193 | P3-n-Mhyt 1356 |
|  1972 |  145 See also |  1197 |  1357 |
|  1969 | | |  1360 |
|  1974 | | |  1354 |
| | | |  1202 |

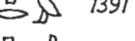
| | | | |
|--|---|--|---|
|  sic 1361 |  1227 and 1229 |  1201 |  1279 |
|  (?) 1363 | See also  |  1275 | See also  |
|  1365 |  1228 |  1274 |  1282 |
|  1367 |  1263 |  1276 |  1280 and 1289 |
|  1362 |  See  |  1312 |  1283 |
|  1364 |  1247 |  1277 |  1285 |
|  1366 |  1248 |  1321 |  1286 |
|  1351 |  1249 |  1323 |  1293 |
|  1371 |  1250 |  1322 |  1294 |
|  1239 |  1251 |  1318 |  1295 |
|  1233 |  1256 |  1319 |  1291 |
| P3-nfr-rh (?) 1234 |  1257 |  1320 |  1292 |
|  1352 |  1255 | See also  |  1294 |
|  1235 |  1254 |  1303 |  1295 |
|  1236 |  1253 |  1304 |  1291 |
|  1237 |  1252 |  1305 |  1292 |
|  1232 |  1258 |  1306 |  1313 |
|  1238 |  1259 |  1307 |  1311 |
|  1240 |  1262 |  1308 |  1310 |
|  1242 | See also  |  1296 |  1314 |
|  1243 |  1260 |  1302 |  1315 |
|  1244 |  1261 |  1297 |  and  |
|  1245 |  1393 |  1298 |  sic  1317 |
|  1204 |  1343 |  1299 |  1399 |
|  1205 |  1345 |  1300 |  1271 |
|  1206 |  1221 |  1301 |  1326 |
|  1210 |  1344 |  1309 |  (?) 1324 |
|  1207 |  1224 |  1288 |  1327 |
|  1209 |  (?) 1225 |  1281 |  1328 |
|  1208 |  1220 |  1287 |  1325 |
|  1226 |  1223 |  1284 |  1337 |
|  1403 |  1203 |  1290 |  1329 |
| |  1265 | | |

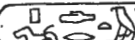
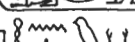
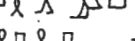









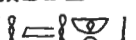

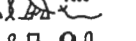
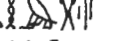

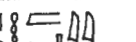
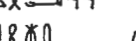
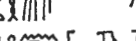
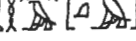

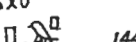

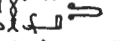

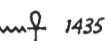
 1330
 1332
 1331
 See also 
 1335
 See 
 1334
 1333
 1336
 1338
 1272
 1404
 1394
 1395
 1212
 1213

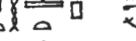
 See 
 1241
 1211
 1402
 1405
 1457
 1458
 1455
 1454
 1456
 1273
 1372
 1373
 Ppy-^cnh Ztw 1374

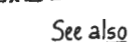
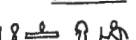
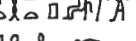



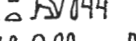





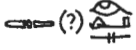

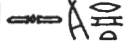

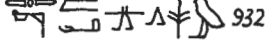

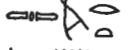









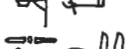









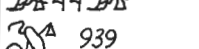





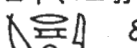

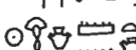

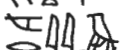

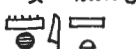

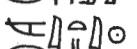



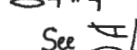
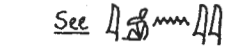

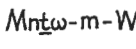

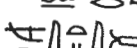



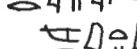









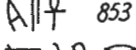





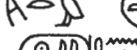

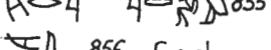

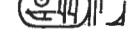
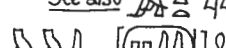
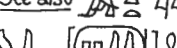
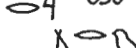

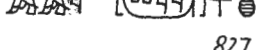
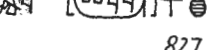







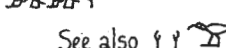
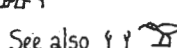
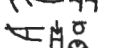



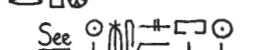
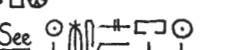





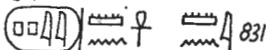
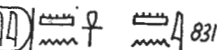
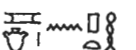



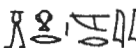









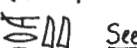

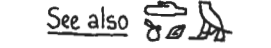
 1375
 See also 
 1376
 1377
 1378
 1379
 1380
 1381
 See also 
 1382
 See 
 1383
 See also 
 1368
 1387
 1385
 1388
 1386
 1389
 1384
 1391
 1390
 1400
 1342
 1339
 1341
 1340

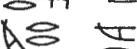
 See 
 1392
 1396
 See 

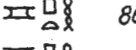









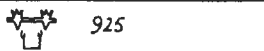

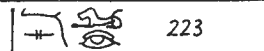



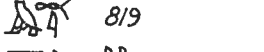

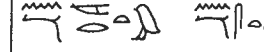
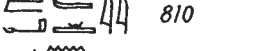
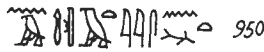
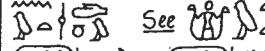

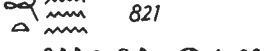



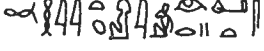

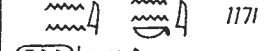
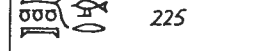

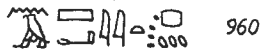

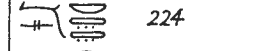

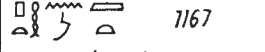

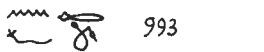

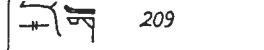
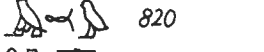
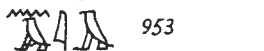

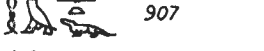

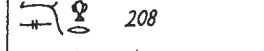
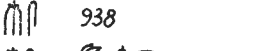

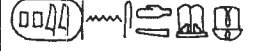

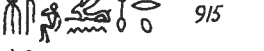



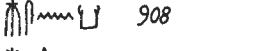

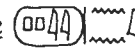
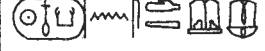
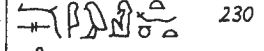
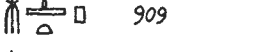



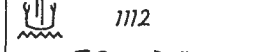
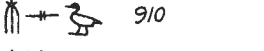



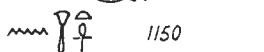
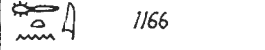

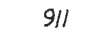

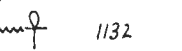

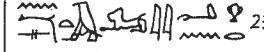

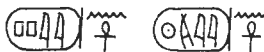

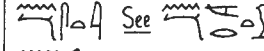
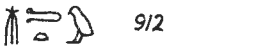

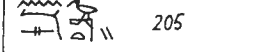



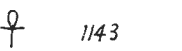

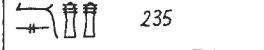
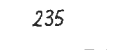

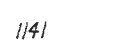

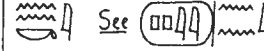
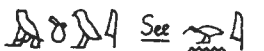

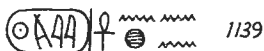

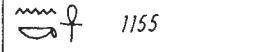

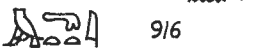
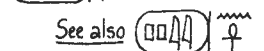



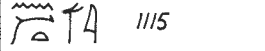

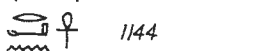

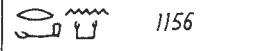

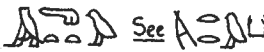

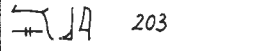
 1397
 1406
 1409
 See 
 1407
 1408
 1410

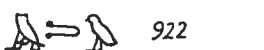
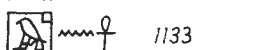
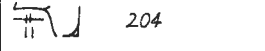
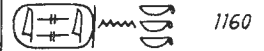

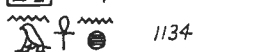

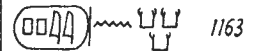
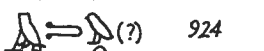
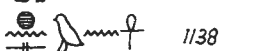
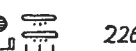
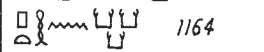
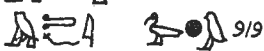
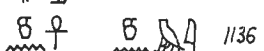
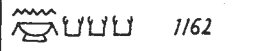



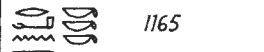

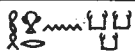

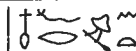
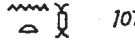

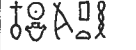

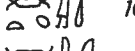



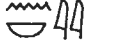

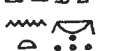



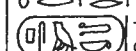
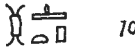
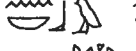
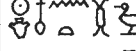
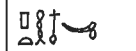
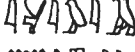
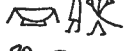

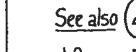
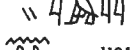



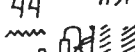
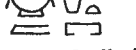

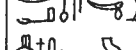
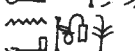

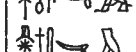
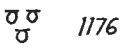



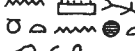
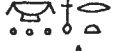

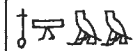
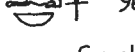
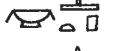

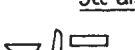
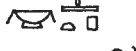
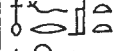
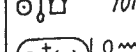
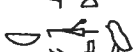
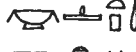
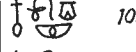
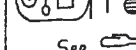

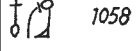
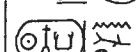

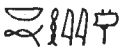
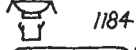

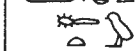
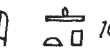
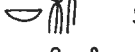
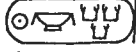

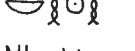
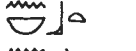
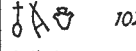
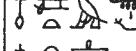
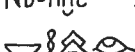
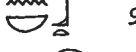

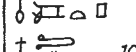





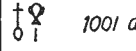
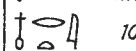
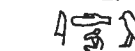
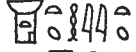
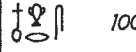

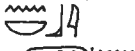

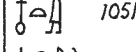
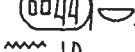
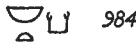

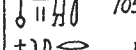
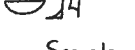

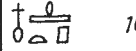
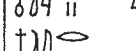

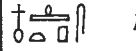
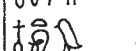

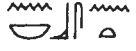
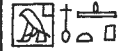

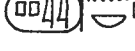

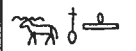





 See 
 1412
 1411
 See also 
 1413

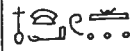









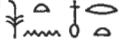







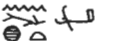





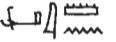

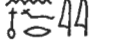

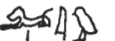

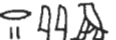









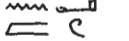

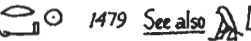



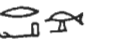



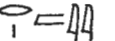
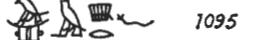

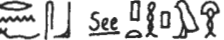

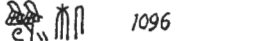



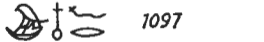

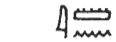





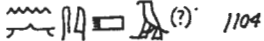
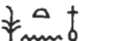

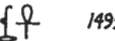

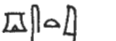



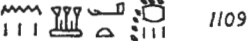
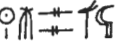

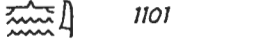
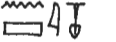
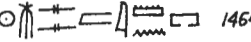

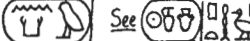

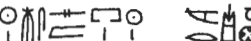

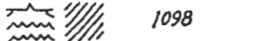





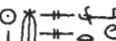





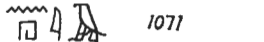







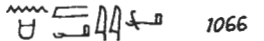



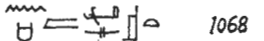





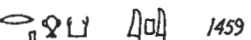

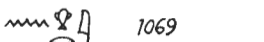
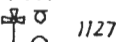
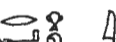
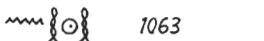

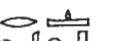
 See 
 1415
 1414
 1416
 1418
 1417
 1421
 1419
 1420
 1452
 1453
 1451
 1446
 1430
 1422
 1427
 1426
 1424





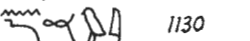

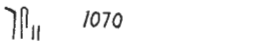

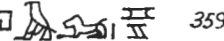





 1425
 1423
 1428
 1429
 1439
 1440
 1441
 1442
 1445
 1444
 1443
 1434
 1435
 1433
 1432
 1431
 See also 
 1437
 1436
 1438
 1447
 1448
 1449
 1450
 See also 
 236
 236 A
 See also 
 200
 812







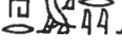



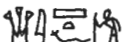
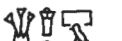

| | | | |
|--|--|---|---|
|  813 |  (?) 928 |  843 and 863 |  874 |
|  926 |  932 |  844 |  875 |
|  811 |  933 |  845 |  876 |
|  927 |  935 |  889 |  903 |
|  937 |  934 |  862 |  905 |
|  948 |  930 |  861 |  904 |
|  816 |  929 |  864 |  878 |
|  817 |  931 |  892 |  879 |
|  939 |  936 |  894 |  869 |
|  944 |  838 |  895 |  885 |
|  940 |  833 |  893 |  877 |
|  947 |  832 |  896 |  878 |
|  See  |  Mntw-m-W3st 840 |  897 |  906 |
|  942 |  841 |  899 |  888 |
|  941 |  882 |  860 |  814 |
|  945 |  865 |  902 |  879 |
|  946 |  853 |  868 |  880 |
|  943 |  867 |  866 |  881 |
|  826 |  A-4 4-3 855 |  877 |  882 |
|  See also  |  856 See also |  873 |  815 |
|   827 |  A-3 857 |  870 |  883 |
|  828 |  884 |  871 |  849 |
|  See also  |  886 |  900 |  850 |
|  829 |  See  |  872 |  851 |
|  830 |  857 |  873 |  847 |
|   831 |  858 |  874 |  848 |
|  836 |  886 |  875 |  849 |
|  837 |  887 |  876 |  852 |
|  835 |  890 |  877 |  848 |
|  839 |  See also  |  901 |  854 |
|  See  |  866 |  904 |  852 |
|  834 |  891 |  877 |  848 |

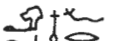
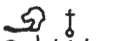

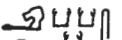
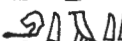

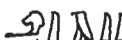
| | | | |
|--|--|--|--|
|  |  925 |  1146 |  223 |
| 818 |  949 |  1148 |  1114A |
|  819 |  1108 |  1149 |  1113 |
|  810 |  950 |  See  | |
|  821 |  952 |  1171 |  222 |
|  822 |  951 |  1102 |  225 |
|  823 |  960 |  1167 |  224 |
|  809 |  961 |  1168 |  207 |
|  820 |  993 |  1169 |  209 |
|  907 |  953 |  1170 |  1173 |
|  938 |  963 |  1153 |  208 |
|  915 |  958 |  1152 |  206 |
|  908 |  959 |  1154 |  221 |
|  909 |  See  |  1166 |  230 |
|  910 |    1135 |  1172 |  1112 |
|  911 |  1150 |  201 |  231 |
|  914 |  1132 |  216 |  232 |
| See also  |    1142 |  218 |  233 |
|  913 |  1143 |  219 |  205 |
|  912 |  1141 |  234 |  235 |
|  824 |    1139 |  1174 |  See  |
|  825 | See also  |  1115 |  1155 |
|  See  |  1140 |  202 |   |
|  916 |  1144 |  203 |  1156 |
|  917 |  1145 |  204 |  1159 |
|  918 |  1133 |  227 |   |
|  See  |  1134 |  226 |  1160 |
|  922 |  1138 |  228 |   |
|  923 |  1136 |  229 |  1163 |
|  (?) 924 |  1137 | See also  |  1164 |
|  919 |  1147 | |  1162 |
|  920 | | |  1161 |
|  921 | | |  1165 |

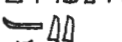

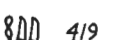

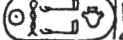



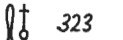







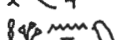
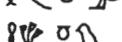

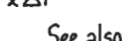

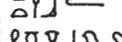
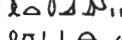
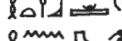
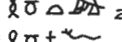
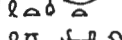
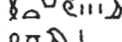
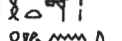
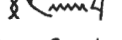
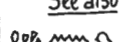
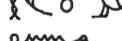
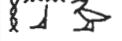

| | | | |
|---|---|---|--|
|  1158 |  977 |  996 |  1021 |
|  1073 |  978 |  997 |  1038 |
|  1077 | <p>See also </p> | <p>Nfr-lb-R^c-nb-ph_{ty}</p> |  1029 |
|  1076 |  992 | <p>See Wd3-Hr-rsnt</p> |  1030 |
|  1074 | <p>See also </p> |  See  |  1028 |
|  1078 |  989 |  998 |  1031 |
|  1075 |  1183 | <p>See also </p> |  1032 |
|  1131 |  1182 |  | <p>See also </p> |
|  1151 |  1178 |  See  |  1033 |
|  1191 |  1177 |  1015 |  1034 |
|  964 |  1187 |  1012 |  1035 |
|  962 |  1188 |  1013 |  1036 |
|  1176 |  1180 |  1014 |  1037 |
|  1190 |  1181 |  1000 |  1016 |
|  966 |  1179 |  1059 |  1017 |
| <p>See also </p> |  1186 |  1058 |  See  |
|  971 |  1184 |  1060 |  See  |
|  991 |  1185 |  1025 |  1018 |
|  973 |  980 |  1026 |  1040 |
|  974 |  981 |  999 |  1042 |
|  976 |  990 |  1027 |  1043 |
| Nb-nht 975 |  986 |  1001 and 1006 |  1048 |
|  967 |  983 |  1003 |  1062 |
|  972 |  982 |  1002 |  1049 |
|  968 |  984 |  1004 |  1039 |
|  969 |  985 |  1007 |  1051 |
| <p>See also </p> |  987 |  1005 |  1050 |
|  965 |  979 |  1008 |  1045 |
|  970 |  988 |  1009 |  1046 |
|  970 |  1189 |  1020 |  1055 |
| <p>See </p> |  994 |  1019 |  1056 |
| |  995 |  1022 |  1041 |
| | <p>See also </p> |  1023 |  1054 |
| | |  1024 | |

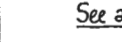
| | | | |
|---|--|--|---|
|  1053 |  1090 |  1124 |  1498 |
|  1044 |  1081 |  1125 |  1476 |
|  1047 |  954 |  1126 |  1461 |
|  1052 |  955 | |  1478 |
|  1011 |  1082 |  1500 |  1507 |
|  1061 |  1089 |  1506 |  1509 |
|  1175 |  1087 |  1503 |  1508 |
|  1057 |  1084 |  1502 |  1510 |
|  1010 |  1085 |  1501 |  1511 |
|  1092 |  |  1479 <i>See also</i>  |  1480 |
|  1091 |  1086 |  1477 |  1504 |
|  1094 |  1088 |  1484 |  1505 |
|  1095 |  956 |  1490 |  <i>See</i>  |
|  1096 |  1083 |  1472 <i>See also</i> |  1491 |
|  1097 |  957 |  |  1492 |
|  1103 |  1111 |  |  1494 |
|  1104 |  1116 |  1471 |  1495 |
|  1105 |  1114 |  1470 |  1496 |
|  1099 |  1109 |  1468 | <i>See also</i>  |
|  1101 |  1110 |  1464 |  1493 |
|  1100 |  <i>See</i>  |  |  1497 |
|  1098 |  1080 |  1465 |  1486 |
|  1106 |  1079 |  1466 |  1488 |
|  1107 |  1122 |  1469 |  1487 |
|  1071 |  1117 |  1467 |  1499 |
|  1072 |  1121 |  1474 |  1489 |
|  1066 |  1119 |  1473 |  1481 |
|  1068 |  1118 |  1475 |  1483 |
|  1067 |  1120 |  1459 |  1482 |
|  1069 |  1127 |  1485 | |
|  1063 |  1128 |  1460 |  307 |
|  1065 |  1129 | <i>See also</i>  |  |
|  1064 |  1130 |  1463 |  330 |
|  1070 |  1123 |  1462 |  359 |

 366
 368
 373
 371
 372
 370
 369
 378
 362
 379
 377
 364
 360
 254
 253



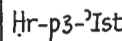





























 See Wn1s-h3-1st.f
 255
 304
 386
 303
 302
 300
 301
 298
 299
 416
 See also 
 419 See also 
 418
 417





































 413
 415
 414
 See 
 See  305
 306
 256
 346
 353
 354
 348
 347
 358
 355
 356
 357
 349
 352
 See also 
 357 A
 350
 351
 319
 320
 324
 322
 323
 325
 321
 326
 329
 327



































 328
 318
 See 
 
 334
 335, cf. 333
 336
 341
 See also 
 345
 342
 344
 343
 337
 340
 339
 338
 332
 See also 
 333, cf. 335
 331
 409
 272
 See also 
 271
 257
 258
 289
 290
 291
 Hr-p3-1st 280































 261
 265
 264
 263
 262
 266
 275
 276
 277
 278
 279
 269
 270
 274
 273
 285
 281
 286
 260
 365
 374
 361 See also
 288
 375
 376
 267
 363
 268
 367
 283
 282
 284
 410













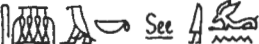











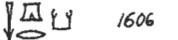

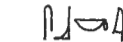

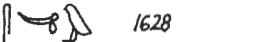







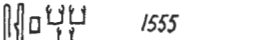



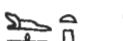

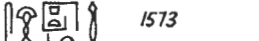





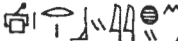







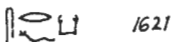



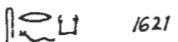









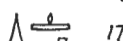

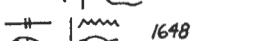
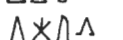



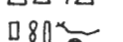

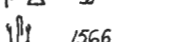

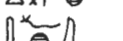

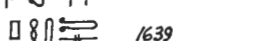

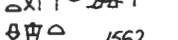





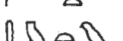

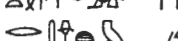

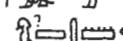

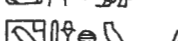
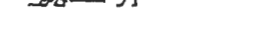
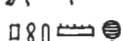

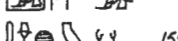
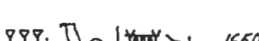
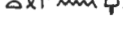

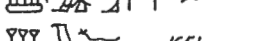

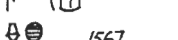
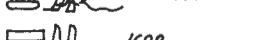
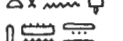

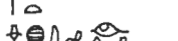
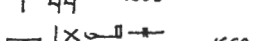
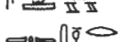

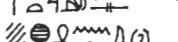
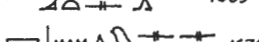
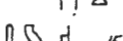



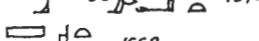
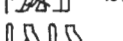

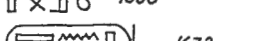



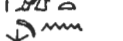

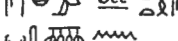
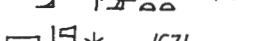
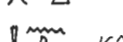

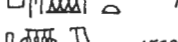
| | | | | | | | |
|---------|-----|--|-----|-----------------|-----|-----------------|-----|
| | 411 | | 392 | | 708 | | 793 |
| | 412 | | 394 | | 710 | | 804 |
| [H]r[w] | 287 | | 395 | | 711 | | 756 |
| | 259 | | 390 | | 712 | | 730 |
| | 380 | | 391 | <i>See also</i> | | | 731 |
| | 382 | | 397 | | 717 | | 749 |
| | 384 | | 398 | | 718 | | 750 |
| | 385 | | 399 | | 714 | <i>See also</i> | |
| | 381 | | 389 | | 716 | | 752 |
| | 383 | | 406 | | 726 | | 754 |
| | 308 | | 396 | | 800 | | 755 |
| | 312 | | 394 | | 801 | | 770 |
| | 309 | | 396 | | 802 | | 775 |
| | 310 | | 388 | | 803 | | 778 |
| | 314 | | 295 | | 799 | | 733 |
| | 311 | | 292 | | 782 | | 734 |
| | 317 | | 293 | | 783 | | 735 |
| | 315 | | 296 | | 784 | | 732 |
| | 316 | | 294 | | 797 | | 779 |
| | 313 | | 297 | | 786 | | 740 |
| | 387 | | 299 | | 788 | | 741 |
| | 387 | | 297 | | 787 | | 737 |
| | 407 | | 299 | | 789 | | 736 |
| | 405 | | 297 | <i>See also</i> | | | 748 |
| | 401 | | 299 | | 798 | | 743 |
| | 400 | | 297 | | 790 | | 744 |
| | 402 | | 299 | | 795 | | 746 |
| | 403 | | 297 | | 794 | <i>See also</i> | |
| | 404 | | 299 | | 796 | | 745 |
| | 393 | | 297 | | 792 | | 738 |
| | | | 709 | | | | |

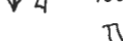
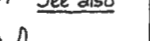

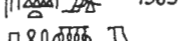



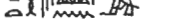







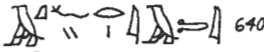





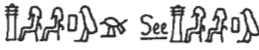

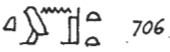



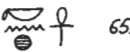
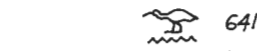
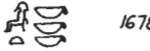

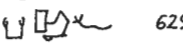



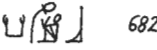

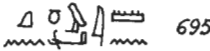

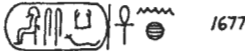





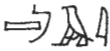
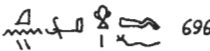

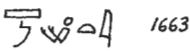



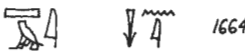
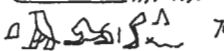
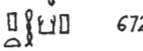
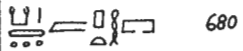

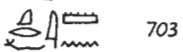
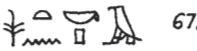

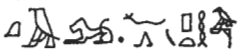













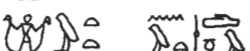



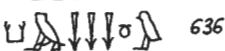

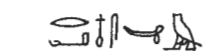

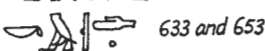
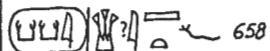
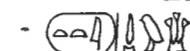
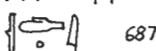
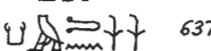
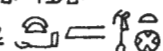
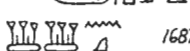

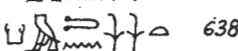

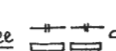
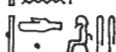
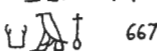
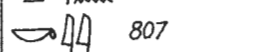



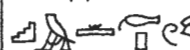

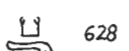

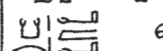
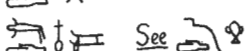



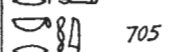
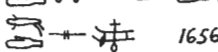

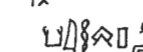

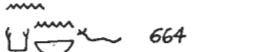
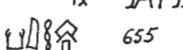

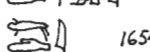

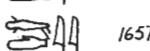

 739
 742
 757
 759
 760
 751
 753
 764
 765
 See 
 771
 773
 774
 See 
 776
 777
 767
 762
 763
 769
 768
 766
 772
 See also 
 See 
 747
 721
 758
 781
 780

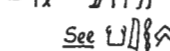
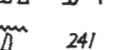
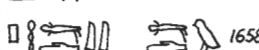



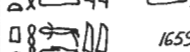

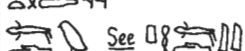

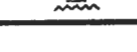





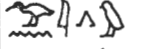
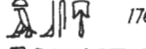

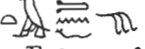
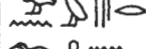

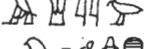
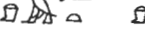
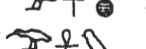
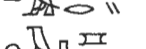



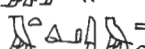

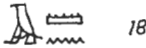



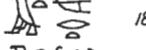
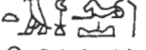
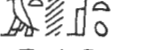

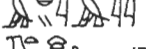
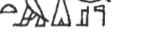
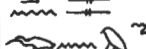
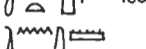



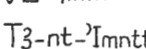

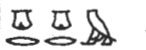

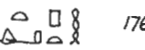
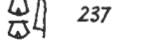

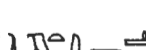
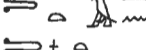

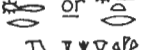
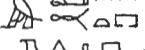







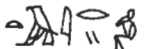
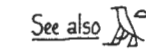
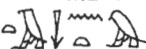



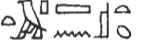
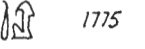
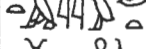
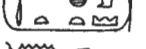

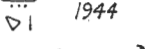
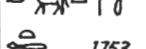
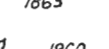

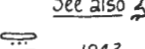
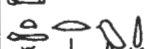
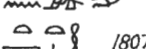

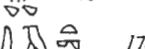



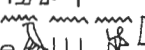



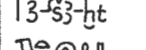
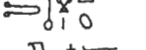
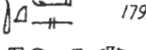
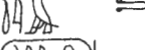
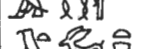
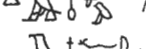
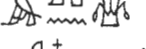
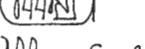
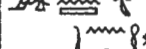
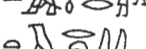

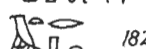





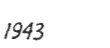

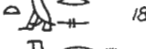

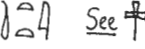

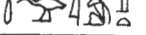
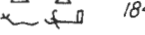



 761
 See 
 See 
 729
 728
 1689
 1693
 1618
 1722
 1697
 1691
 1694
 1692
 1701
 1702
 1703
 1698
 1699
 1700
 1695
 1696
 1724
 1717
 1715
 1716
 1713
 1704
 See 
 1714
 1712
 1730
 1731
 1729











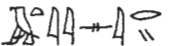

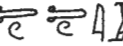

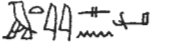

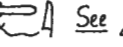
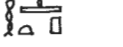



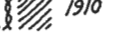

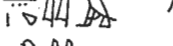
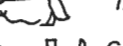
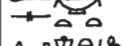

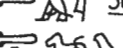
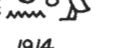
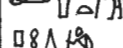



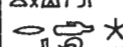
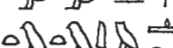
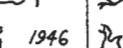

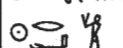

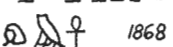

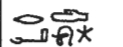
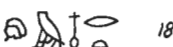
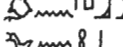
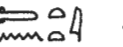

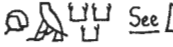

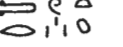
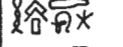
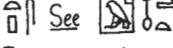

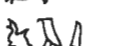

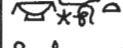
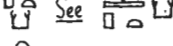

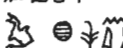
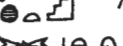
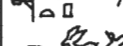
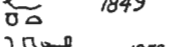
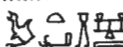
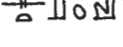
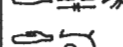

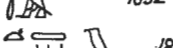

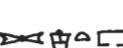
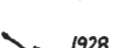
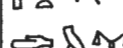
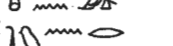
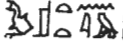
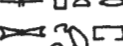

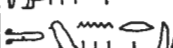
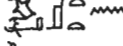
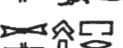
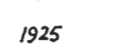
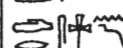



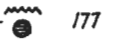

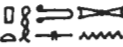





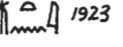
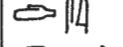

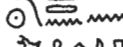
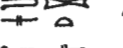

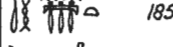
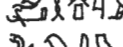
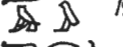
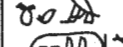

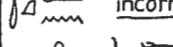
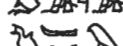
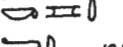
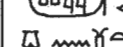
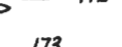
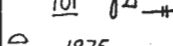
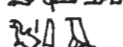
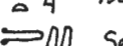

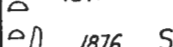
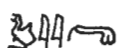

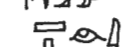
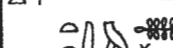





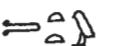

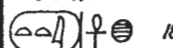

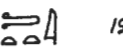

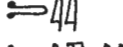
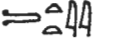

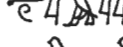
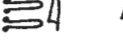
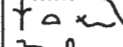

 1723
 1721
 1719
 1720
 1705
 1707
 1708
 1709
 1710
 1711
 1718
 1727
 1726
 1725
 1706
 1728
 1619
 1733
 1732
 1734
 1582
 1611
 1615
 1622
 1623
 1554
 1635
 See also 
 1634
 1630
 1631
 1632
 1633 See also

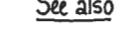
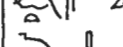



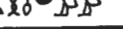





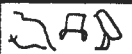
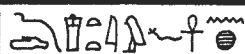

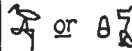



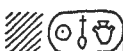

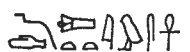
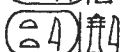
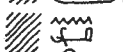
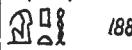

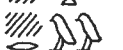



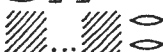







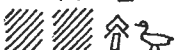

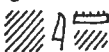
 1643
 See also Ppy-Grh
 1638
 1641
 1645
 1646
 1528
 1527
 1529
 1512
 1513
 1518
 1514
 1515
 1516
 1517
 1519
 1520
 1690
 1521
 1526
 1525
 1522
 1523
 1524
 1750
 1751
 1752
 1530
 1532
 1531

| | | | |
|--|--|---|--|
|  1534 |  1608 |  1743 |  See  |
|  1543 |  1597 |  1744 |  1626 |
|  1535 |  1609 |  1745 |  1625 |
|  1536 |  1610 |  1606 |  1627 |
|  1537 |  1598 |  1601 |  1628 |
|  1539 |  1600 |  1603 |  1629 |
|  1540 |  1599 |  1604 |  1555 |
|  1538 |  1612 |  1605 |  1572 |
|  1541 |  1613 |  1602 |  1573 |
|  1542 |  1614 |  1624 |  1575 |
|  1746 |  1584 |  1620 |  1574 |
|  1533 |  1616 |  1621 |  1636 |
| See also  |  1617 |  1550 |  1647 |
|  1749 |  1747 |  1552 |  1637 |
|  1748 |  1588 |  1551 |  1642 |
|  1547 |  1593 |  1553 |  1648 |
|  1546 |  1594 |  1566 |  1649 |
|  1548 |  1592 |  1556 |  1644 |
|  1549 |  1595 |  1562 |  1639 |
|  1583 |  1589 |  1560 |  1640 |
|  1578 |  1596 |  1561 |  1544 |
|  1735 |  1590 |  1557 |  1545 |
|  1736 |  1585 |  1558 |  1650 |
|  1737 |  1591 |  1559 |  1651 |
|  1579 |  1586 |  1567 |  1688 |
|  1581 |  1587 |  1569 |  1669 |
|  1580 |  1783 |  1568 |  1670 |
|  1577 | See also  |  1571 |  1668 |
|  1576 |  1739 |  1570 |  1673 |
|  1607 See also  |  1742 |  See  |  1672 |
|  1581 |  1740 |  1565 |  1671 |
|  1580 |  1741 |  1563 |  1675 |
|  1577 |  |  1564 |  1682 |
|  1576 |  |  |  |
|  1607 See also  |  |  |  |
|  |  |  |  |

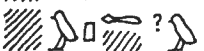
| | | | |
|--|---|--|---|
|  1680 |  1653 | K3-z-nb.f, <i>See</i>  | <i>See also</i>  |
|  |  640 |  649 |  660 |
|  1681 |  674 |  650 |  678 |
|  <i>See</i>  |  706 |  630 |  641 |
|  1674 |  686 |  652 |  642 |
|  1678 |  691 |  629 |  642 |
|  1679 |  694 |  682 |  643 |
|  1676 |  695 |  683 |  679 |
|  1677 |  697 |  684 |  662 |
|  1661 | Kn-nht 698 |  681 |  651 |
|  1662 |  696 |  692 |  685 |
|  1663 |  170 |  670 |  657 |
|  1664 |  700 |  672 |  680 |
|  1665 |  703 |  671 |  668 |
|  1666 |  702 |  673 |  669 |
|  1667 |  701 |  632 | K3p.s-pw 669 |
|  1683 |  704 |  634 |  661 |
|  1684 |  805 |  635 |  644 |
|  1685 |  805 |  631 |  645 |
|  1686 <i>See also</i> |  690 |  636 |  677 |
|  |  687 |  633 and 653 |  658 |
|  |  688 |  637 | <i>See</i>  806 |
|  1687 |  689 |  638 |  807 |
|  <i>See</i>  |  628 |  667 |  693 |
|  1660 |  628 |  676 |  699 |
|  1652 |  656 |  647 |  705 |
|  <i>See</i>  |  666 |  654 |  238 |
|  1656 |  664 |  655 |  240 |
|  1655 |  665 |  <i>See</i>  |  241 |
|  1654 |  639 |  646 | <i>See also</i>  |
|  1657 |  663 |  648 |  |
|  1658 |  675 |  659 |  |
|  1659 | | |  |
|  <i>See</i>  | | |  |

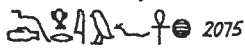
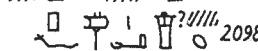
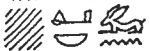
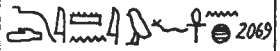
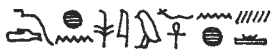
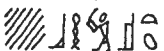
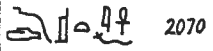
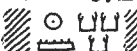
| | | | |
|---|---|---|---|
|  249 |  1759 |  1778 |  1835 |
|  248 |  1760 |  1780 |  1836 |
|  251 |  1816 |  1784 |  1837 |
|  242 |  1818 |  1779 | |
|  243 |  1817 |  1781 |  1761 |
|  244 |  1806 |  1782 |  1763 |
|  245 |  1804 |  1783 |  1762 |
|  247 |  1805 |  1797 |  1770 |
|  250 |  1812 |  1803 |  1772 |
|  246 |  1862 |  1796 | |
|  239 |  1858 |  1798 |  1773 |
|  252 | T3-nt-Imtt 1857 |  1802 |  1768 |
|  237 |  See  |  1801 |  1769 |
| |  1867 |  1800 |  1765 |
|  1787 |  1865 |  or  1799 |  1764 |
|  1942 |  1866 |  1833 |  1766 |
|  1754 |  1813 |  1834 |  1767 |
|  1788 |  1859 |  1824 |  1771 |
|  1789 | See also  |  1825 |  1774 |
|  1846 |  1861 |  1832 |  1775 |
|  1786 |  1864 |  1830 |  1944 |
|  1753 |  1863 |  1826 | See also  |
|  1756 |  1860 |  1831 |  1843 |
|  1758 |  1807 |  1828 |  1785 |
|  1755 |  1815 |  1827 |  1814 |
| T3-s3-tt 1757 |  1809 |  1829 |  1940 |
|  1839 |  1808 |  1793 |  =  1941 |
|  1844 |  1810 |  1791 |  1886 |
|  1840 |  1811 |  1794 |  See  |
|  1841 |  1823 |  1790 |  =  |
|  1842 |  1821 |  1792 |  1949 |
|  1838 |  1820 |  1795 |  1943 |
| | 1822 | 1776 | See |
| | 1819 | 1777 | 1848 |

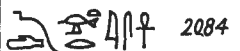
| | | | |
|--|--|---|--|
|  1847 |  See  |  1939 |  1933 |
|  1874 |   1883 |  See  |  191 |
|  1873 | Tty 1885 |   1910 |  181 |
|  1845 | Teti-harsiēsi(?) 1880 |  1911 |  182 |
|  1947 |  1887 |  See  |  192 |
|  1945 |  1888 |   1914 |  193 |
|  See  |  1889 | Tnnt 1915 |   195 |
|  1946 |  1882 |  1918 |  196 |
|  1868 |  1905 |  1916 | See also  |
|  1869 |  1890 |  1917 |  194 |
|  See  |  1936 |  1919 |  197 |
|  See  |  1893 |  1851 |  198 |
|  1849 |  1891 |  1913 |   199 |
|  1852 |  1896 |   1922 |  176 |
|  1853 |  1902 |  1928 |  174 |
|  1854 |  1897 |   1927 |  175 |
|  1855 |  1898 |  1925 |   177 |
|  1856 |  1895 |   1926 |   178 |
|  1870 | Tz̄i-Bz̄stt-Im-w 1904 |   1923 |   179 |
|  1871 |  1903 |  1924 |  179 |
|  1872 |  1901 |  1920 |   172 |
|  1850 |  1899 |  1912 |   173 |
|  incorrectly |  1900 |  1932 |  171 |
| for  |  1894 |  See  | |
|  1875 |  1909 |  1934 |  2068 |
|  1876 See also |  1907 |  1935 |   2067 |
|   |  1908 |  1929 | Names beginning with this sign under Tp... |
|  1884 |  1906 |  1930 |  2063 |
|  1877 |  1948 |  1931 |  2071 |
|   1878 |  1937 | See also  |  2072 |
|  1879 |  1938 |   |  2073 |
|   1881 | | | |
|  1882 | | | |

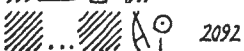
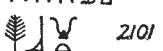
| | | | |
|---|--|--|---|
|  2074 |  2082 |  2064 | ...ms 2093 |
|  or  183 | | See also   |  2095 |
|  185 |  2083 |  |  2094 |
|  188 |  2065 | |  2097 |
|  186 |  2081 |  2089 |  |
|  189 |  2076 |  2099 |  2096 |
|  190 |  2077 |  2090 |  |
|  184 |  2078 |  2085 | See  |
|  187 | See also  |  ? |  2088 |
|  2079 |  2075 |  2098 |  2087 |
|  2069 |  2080 |  2086 | |
|  2070 | |  2091 |  2100 |
|  2084 |  2066 |  2092 |  2101 |

3. DIVINITIES

- Aker, 507.
 Amenōpet, 860.
 Amen-rē', *see* Amūn.
 Amūn (Amen-rē'). Statuette, 870. In scene, 687, 806, 846, 853, 853, 858, 860; as ram, 860, 860; as crio-sphinx, 554. Mentioned in offering-text, 592. In titles, of Diospolis Inferior, 848; at Karnak, 848; of Khentnūfer, 803; of Ōpet, 866; of Peru-nūfer, 556; unspecified, 552, 562, 654 (domain of), 654 (Great-of-Victories), 661, 661, 666, 667, 667 (domain of), 669, 675, 675, 702, 707, 707, 709, 715, 715, 717, 718 (boat-name), 718, 726 (domain of), 726, 729, 729, 733, 734, 737, 737, 763, 771, 771, 771 (Great-in-Victory), 773 (domain of), 775 (domain of), 781, 787, 798, 811, 811, 821, 822, 834, 858, 859, 861.
 'Anta, 824.
 Anubis. In scenes, 418, 427, 428, 554, 559, 664, 668, 688, 704, 705, 754, 777, 781, 841, 845, 846; as jackal, 649, 650, 655. In titles, 419, 427, 449, 559, 812.
 Apis and Apis-bull. Tombs with stelae, canopic-jars, etc., 780-805; *see also* canopic-jars, 819; jars dedicated to, 820, 820; offering-table dedicated to, 819. Chapel, 780. Embalming house, 841. Temple, in titles, 727. Statues, bull-headed, 669, 849; figure held by statue, 817; as bull, 592, 779, 780, 818; figure held by statue, 862. In scenes, 779, 782, 783, 783, 783, 784, 785, 786, 786, 786, 787, 788, 789, 790, 791, 797, 797, 806, 807, 810, 817, 821; as bull (on Apis-stelae, pp. 781-817, *passim*), 573, 738, 777, 779, 780, 781, 817, 819, 826, 827, 829, 842, 850, 871. Dummy mummy, 825. Mention on embalming-table, 841. In titles, 781, 784, 806, 812, 816.
 Astarte. In scene, 833. Stela dedicated to, 871. In titles, 717, 873.
 Aten, The. In titles, 557, 657, 666, 737, 775. Cartouches, 592, 862, 863, 872.
 Atum. Naos held by statue, 867. In scenes, 434, 556, 660, 701, 707, 846.
 Baal, 717.
 Bes. Chapel, 777. Statues, 652, 777, 779; statue in scene, 555. In scene, 777.
 Bubastis. In scenes, 403, 823, 854. In titles, 453, 571, 571, 711, 746, 798, 823; Mistress of 'Ankhtauī, 553, 800, 805, 811; of Heliopolis, 503; of the Two Lands, 789.
 Bull, *see* Cows.
 Buto. In scenes, 394, 395, 424, 427, 427, 427. In titles, 638, 813, 814.
 Cows, Bull and seven, 554.
 Duamutf. In scenes, 418, 665, 820. (Omitting Duamutf canopic-jars.) *See also* Horus, Sons of.
 Duau. In titles, 404, 426, 768.
 Duawēr. 428.
 Eastern goddess. 720.
 Ennead. 421.
 Ḥa. In titles, 771, 800, 800, 801, 801, 808.
 Ḥa'pi. 428.
 Ḥaremakhet. 803.
 Harpocrates. Naos of, held by statue, 862. In scene, 824. In title, 813.
 Harsaphes. In titles, 801, 803.
 Ḥathor. Temple, 852. Statue, 869; as cow, 670. Naos of, held by statue, 848. *Menat*, 663. In scenes, 424, 427, 555, 557, 665, 669, 685, 701, 715, 740, 786, 846, 846, 850, 853, 853, 853, 858, 871; as cow, 589, 654, 662, 662, 667, 702, 714, 740, 855, 871. Ḥathor emblem/head, 838, 859, 861, 865, 866. Ḥathor-pillars, columns, and column capitals, 412, 755, 841, 853. Mentioned on sistrum (Mistress of Dendera), 829; in text, 660. In titles, *passim* (for Old Kingdom and 1st Int. Period titles *see* Appendix G).
 Ḥeka. In titles, 451, 634.
 Ḥeḳes. 428.
 Ḥeḳet. In titles, 502, 633, 762, 812.
 Ḥephep (Ḥepui). 428.
 Ḥepy. 665. (Omitting Ḥepy canopic-jars.) *See also* Horus, Sons of.
 Horus. Statues, 779 (as hawk), 826, 827, 827, 869. In scenes, 426, 554, 685, 781, 813, 846, 853, 854, 861. Horus standard, in scene, 856. 'Horus on crocodiles' stelae (cippi), 851, 862, 862. In titles, *passim* (for Old Kingdom and 1st Int. Period titles *see* Appendix G).
 Horus Beḥdetite. In scenes, 418, 422, 426 (as hawk).
 Horus *km-r*. In titles, 443, 450.
 Horus, Sons of. In scenes, 668, 719, 763, 781, 782, 846, 871. *See also* Duamutf, Ḥepy, Imset, Ḳebḥsenuf.
 Horus, Souls of. 428.
 Horus-Khentekhtai. In titles, 738, 738.
 Imḥōtep. *See* Index 2.
 Imset. 665. (Omitting Imset canopic-jars.)
 Inmutf. 418.
 I'oh. 873.
 Isis. Statues, 652, 670, 779, 826, 827, 843. In scenes, 557, 702, 707, 717, 740, 749, 778, 781, 781, 783, 792, 792, 794, 794, 808, 809, 824, 826, 846. Dedication to, on shrine-panel, 824. In titles, 664, 744, 759, 767, 798, 799, 801, 803. Isis Mother-of-Apis. Burial place, 827.
 Ḳebḥsenuf. In scenes, 665, 820. (Omitting Ḳebḥsenuf canopic-jars.)
 Khem. 868.
 Khnum. In scene, 428. In titles, 453, 482, 634, 771.
 Khons. In scene, 573. Mention on donation-stela, 780. In titles, 789, 824.
 Khonspekhrod. 789.
 Ma'et. In scenes, 557, 660, 846, 859; image of,

- being offered, 844, 850, 860, 860, 861. In titles, 632, 722, 737.
- Mendes, Ram of. In titles, 507, 810.
- Mert. In scenes, 427, 850. In title, 639.
- Mest. 418.
- Min. In scenes, 427, 428, 667, 877. Shrine, 874. In titles, 567, 743, 743, 765, 861.
- Min-Amūn. 853.
- Mnevis-bull. 783.
- Monthu. In scene, 428. In title, 766.
- Mut. Statue, 825. In scenes, 853, 858, 873. Mentioned on column-fragment, 592. In titles, 504, 767, 786.
- Na'ry. 507.
- Nefertem. In scene, 855. On decorated mummy-wrapping, 825. In title, 790.
- Neḥi. In scenes, 823, 860 (as bird).
- Neith. Statue, 869. On vessels, represented, 403, mentioned, 402. Name on cylinder-seal, 436. Shrine, 874. In titles, *passim* (for Old Kingdom and 1st Int. Period titles see Appendix G).
- Nekhbet. In scenes, 394, 427, 427, 427, 428, 428. In titles, 577, 812.
- Nekhen, Souls of. In scenes, 393, 421, 428, 701, 825, 846. In title, 404.
- Nemti. 577.
- Nephtys. Statues, 652, 843. In scenes, 591, 707, 781, 781, 793, 808, 809, 820, 846. In title, 799.
- Nepri. 429.
- Nile-gods. In scenes, 393, 418, 426, 428, 429, 831, 855, 855, 856, 877.
- Nut. In scenes, 504, 506 (as sycamore-tree), 720, 846. In title, 725.
- Onuris. Statue, 778. In title, 691.
- Osiris. Statues, 652, 670, 819, 819, 828, 849, 849, 869. Figure of, usually held by statue, 613, 722, 822, 822. Naos of, held by statue, 666, 706, 707, 726, 838, 867. In scenes, 507, 557, 557, 557, 559, 572, 572, 590, 590, 590, 590, 590, 613, 649, 660, 665, 665, 666, 667, 668, 668, 668, 688, 701, 702, 706, 707, 707, 740, 749, 749, 749, 755, 773, 781, 781, 781, 783, 783, 783, 784, 798, 826, 828, 845, 846, 846, 860, 871. Shrine, 874. Temple, mentioned in text, 854. In titles, 507, 721, 746, 748, 763, 813, 849.
- Osiris-Apis, see Serapis.
- Osiris-Onnophris. 664.
- Pe, Souls of. In scenes, 429, 701, 825, 846, 851.
- Ptah. Temples, 831, 854. Statues, 823, 825, 828, 828, 833, 836, 843, 859, 868, 868. Figure of, usually held by statue, 727, 728, 821, 821, 822, 822, 822, 838, 838, 858, 860, 864. Naos of, held by statue, 665, 707, 822, 838, 839, 861, 866, 867, 867. Standard of, held by statue, 863. Shrine, 874. Representation of Pylon of Temple of, 849. Other references *passim*.
- Ptah-Sokari. In scenes, 557, 573, 660, 810. Naos of, held by statue, 866. Mentioned in offering-text, 899. In title, 552.
- Ptah-Sokari-Apis. 867.
- Ptah-Sokari-Osiris. Statuettes, 650, 720. Naos of, held by statue, 785, 818. In scene, 555.
- Ptah-tatanen. Statue, 835. Figure of, at front of block-statue, 838.
- Ram 'Lord of Per-ka'. 821.
- Rēc. In scene, 559. Hymn to, *passim*. In titles, *passim* (for Old Kingdom and 1st Int. Period titles see Appendix G).
- Rēc-Ḥarakhti. In scenes, 395, 434, 556, 559, 655, 660, 660, 666, 706, 707, 714, 716, 749. Naos of, held by statue, 726. Hymn to, *passim*.
- Rēc-Ḥarakhti-Atum. 706.
- Rēc-Ḥaremakhet. 427.
- Reshef. In scenes, 849, 861.
- Sed. 596.
- Sefkhet-abu. 853.
- Sekhmet. In scenes, 553, 665, 760, 763, 831, 832, 833, 840, 843, 849, 850, 853, 860, 870, 871, 871, 873, 873, 875. Standard of, in scene, 709. Mentioned in offering-text, 845. In titles, 638, 707, 707, 718, 801, 802, 802, 803, 811, 812, 812, 812, 824.
- Selkis. 760.
- Semset. 831, 874.
- Sepa. 418.
- Serapis (Osiris-Apis). In titles, 748, 803, 803, 812, 814, 814.
- Seshet. In scenes, 427, 877. In titles, 449, 452.
- Sēth. Statue, 870. In scenes, 394, 394, 424, 426, 428, 428, 828, 855. Standard of, in scene, 856. Mentioned in text, 394. In titles, 736, 736.
- Sēth, Souls of. 428.
- Sēth-nubti. 685.
- Shesmetet. 805.
- Shu. 846.
- Sobk. Statue, as crocodile, 556. In scenes, 687, 861. In title, 800.
- Sokari. Statue, as hawk, 823. In scenes, 418, 742, 846, 846. Bark of, in scenes, 554, 851. In titles, 453, 499, 689, 762, 765, 788, 793, 795, 805, 829.
- Sokari-Osiris. 806.
- Sopt. In scene, 418. In titles, 403, 502.
- Termuthis. In scene, 871. Shrine, 874. In title, 501.
- Theban triad. 828.
- Thoth. Statue, 869. Standard of, held by statue, 863. In scenes, 418, 554, 554, 554, 573, 660, 664 (as baboon), 759, 853, 861. In titles, 502, 676, 764, 819, 872.
- Tree-goddess. In scenes, 506, 665, 668, 669, 688, 707, 708, 716, 761.
- Tuēris. Statues, 819, 844.
- Tutu. 828.
- Wepwaut. 592.
- Wert-ḥekau. In titles, 726, 809.
- Western goddess. In scenes, 505, 506, 592, 701, 717, 720, 746, 786, 826.
- Wind-gods. In scenes, 612, 767.
- Zefa. 429.
-  (bull-headed god, perhaps Serapis). 828.

4. GEOGRAPHICAL

Names in italics are Ancient Egyptian, names in capitals classical. The article *el-* does not affect the alphabetical order of the place-names. References to toponyms which do not occur in titles are indicated by an asterisk

- Abû Ghurâb, 835*.
 Abûšîr, 698*.
Abuy-neteru, 786.
 Abydos, 670*, 671*, 738*, 742*.
Ankhtau, 553, 651, 800, 805, 811.
Anu, 773.
 APHRODITOPOLIS, 858.
Asher, 504, 767.
 Asyût, 765.
 ATHRIBIS, 738, 738.
 BUSIRIS, 507, 612.
 Dendera, 633, 829, 859.
Dep, 813.
 DIOSPOLIS INFERIOR, 848.
 Farâfra Oasis, 721.
 Gîza, 692*, 693*.
Hebnu, 810.
 HELIOPOLIS, 503, 733, 838.
 HERACLEOPOLIS MAGNA, 788, 788.
 HERMONTIS, 859.
Her-wër, 482, 771, 812.
Hetept, 786, 789, 853.
 Hôd el-Wissada, 863*.
Hurent, 507.
Ida, 501.
Itefwër, 746.
 Karnak, 848.
Khanûfer, 786, 789, 812.
Khentnûfer, 803.
Kush, 860.
 LETOPOLIS, 738, 743, 765, 771, 788, 790, 799, 804, 810, 811, 812, 812, 813, 813, 813, 813, 814, 868.
 LETOPOLITE nome, 493.
 Lisht, 551.
Macti, 725.
 MEMPHIS, *passim*.
 MENDES, 507, 810.
Mesen, 579.
 el-Minya, 874*.
 Nag^c el-Deir, 691*.
Nekheb, 585, 694, 723, 812.
Nekhen, 543, 577, 627, 633, 769, 823. Souls of Nekhen, *see* Index 3.
Nent, 744.
Nidua-snefru, 678.
Ôpet, 866.
 Oryx-nome, 405.
 PANOPOLIS, 567, 687, 743, 743, 861.
 PANOPOLITE nome, 689.
Pe, 591, 813. Souls of Pe, *see* Index 3.
Per-henu, 858*.
Per-ka, 821.
Per-sekhem-kheper, 858*.
Peru-nûfer, 556, 737.
 PHARBAETHOS, 819.
Ra-setau, 587, 748, 799, 800, 801, 803, 805, 811, 811, 813, 814, 816, 816.
 SAIS, 775, 799, 813, 839.
 SEBENNITE nome, 768.
Serer, 501.
Shendi, 802.
Shenwet (?), 451.
Smen-ma'et, 788.
 'Star of Horus Foremost of Heaven', 723.
Tadehmet, 743.
 TANIS, 862*.
Tepa, 501.
 THEBES, 766, 831*, 862*.
Thenent, 801, 826.
 THINITE nome, 685, 691.
 Tûra, 586.
 Wâdi Naṭrûn, 859.
Wenet, 501, 749.
 nome, 443.

5. OBJECTS IN MUSEUMS

- ABERDEEN, Anthropological Mus.
Statue, 1385, p. 480. **Blocks**, 1556, p. 464; 1558a-c, p. 456; 1560, p. 456.
 AIX-EN-PROVENCE, Musée Granet
Blocks, 1, 2, p. 490.
 ALEXANDRIA, Graeco-Roman Mus.
Stela, p. 786. **Canopic-jars**, 1322, p. 772; ?, p. 670.
 AMSTERDAM, Allard Pierson Mus.
Stela, 7762, p. 777. **Blocks**, 7790-1, p. 749; 8752, *see* Addenda.
 ANTWERP, Mus. Vleeshuis
Statues, 79.1.234, p. 827; 79.1.284, p. 720. **Stela**, 79.1.457, p. 815. **Lintel**, 79.1.152, p. 749. **Canopic-jars**, 79.1.153-6, p. 772.
 ATHENS, National Mus.
Statue, 919, p. 480.
 BALTIMORE (Md.), Johns Hopkins University Mus.
Sphinx, 9210, p. 869.
 BALTIMORE (Md.), Walters Art Gallery
Statue, 22.106, p. 714. **Stela**, 22.123, p. 732. **Blocks**, 22.38, p. 718; 22.83, p. 749; 22.86, p. 662; 22.152-3, p. 718; 22.286, p. 750; another, p. 718.
 BASEL, Mus. für Völkerkunde
Blocks, III.5219, p. 579; III.5220, p. 828.
 BERKELEY, University of California, Robert H. Lowie Mus. of Anthropology
Sarcophagus-lid, 5.522, p. 649.

BERLIN, Staatliche Museen

EAST BERLIN

Statues, including sphinxes

| No. | Page |
|--------|------|
| 1121 | 837 |
| 1205 | 863 |
| 2085 | 838 |
| 2274 | 868 |
| 7553 | 868 |
| 7701 | 864 |
| 7778 | 778 |
| 8808-9 | 848 |
| 8810 | 864 |
| 10289 | 867 |
| 11332 | 866 |
| 14277 | 500 |

False-doors (and parts) and stelae

| No. | Page |
|---------|------|
| 1118-19 | 700 |
| 1120 | 492 |
| 1141 | 500 |
| 1151 | 544 |
| 2144 | 815 |
| 7269 | 732 |
| 7270-1 | 664 |
| 7272 | 734 |
| 7273 | 733 |
| 7274 | 664 |
| 7276 | 733 |
| 7279 | 733 |
| 7281 | 733 |
| 7289 | 733 |
| 7290 | 715 |
| 7304 | 734 |
| 7305 | 664 |
| 7306-7 | 733 |
| 7308 | 734 |
| 7314 | 733 |
| 7315-16 | 734 |
| 7317 | 733 |
| 7318 | 734 |
| 7320 | 557 |
| 7321 | 733 |
| 7728 | 582 |
| 7767 | 732 |
| 7779 | 732 |
| 8169 | 872 |
| 14333 | 732 |
| 15393 | 872 |
| 15790 | 891 |

Decree, 17500, p. 876.

Blocks, etc.

| No. | Page |
|--------|------|
| 1115 | 575 |
| 1116 | 750 |
| 1124 | 525 |
| 1131-2 | 491 |
| 1133 | 492 |
| 1153 | 686 |
| 1185 | 400 |

| No. | Page |
|---------|------|
| 1631-2 | 714 |
| 2070 | 666 |
| 2087 | 556 |
| 2088-9 | 662 |
| 2281 | 589 |
| 7275 | 716 |
| 7277-8 | 716 |
| 7322 | 707 |
| 7730 | 750 |
| 12410 | 750 |
| 12411 | 711 |
| 12412 | 750 |
| 13297 | 750 |
| 14100-1 | 579 |
| 14642 | 750 |
| 14667 | 430 |
| 15004 | 577 |
| 15071 | 750 |
| 15414 | 719 |
| 19782 | 751 |
| 20363 | 656 |
| 22663 | 655 |
| 23673 | 751 |
| 24042 | 751 |

Tomb-chapel, 1105, p. 493; part, 1108, pp. 575-7.

Papyrus-columns, 1627-8, p. 707; column-fragment, 1446, p. 592; column-base, 2286, p. 708.

Sarcophagi and coffins

| No. | Page |
|---------|-------------------------|
| 29 | 720 |
| 33 | 709 |
| 41 | 763 |
| 57 | 703 |
| 2123 | 506 note 1, and Addenda |
| 10183-4 | 517 |
| 10185 | 517 (twice) |
| 10616 | 517 |
| 13101-4 | 517 |

Mummy-cartonnage, 13149, p. 495.

Offering-tables, etc., 1139-40, p. 691; 1159, p. 498; 1184, p. 686; 1201-2, p. 691; 2273, p. 706.

Canopic-jars, 7170, p. 772; 7171, p. 773; 7173, p. 773; 7174, p. 772; 7180, p. 772; 7183, p. 772.

Pyramidion, 2276, p. 713. Offering-stands, 1111-12, p. 691; 1144-5, p. 691; 1193-4, p. 691. Jar, 7715, p. 423. Palette, 3427, p. 712.

LOST, OR UNIDENTIFIED IN EAST BERLIN

Sphinx, 7777, p. 778.

False-doors and stelae, 822, p. 734; 1142, p. 500; 1143, p. 674; 2118, p. 506 and Addenda; 3423, p. 815; 7494, p. 842; 7707, p. 734; 12748, p. 734; 15302-3, p. 500; 21615, p. 734.

LOST, OR UNIDENTIFIED IN EAST BERLIN (*cont.*):**Blocks, etc.**

| <i>No.</i> | <i>Page</i> |
|---------------------------|-------------|
| 1110 | 492 |
| 1134 (now in Gotha) | 492 |
| 1135 (now in Portugal) | 575 |
| 1152 | 686 |
| 2282 | 589 |
| 7495 | 751 |
| 7727 | 828 |
| 7768 | 751 |
| 8816 | 751 |
| 14099 | 578 |
| 14945 | 751 |
| 20365 (now in Copenhagen) | 756 |
| 23798 | 751 |

Sarcophagus, 31, p. 763. **Coffin-planks**, 13100, p. 547.

Offering-table, 7723, p. 767. **Head-rests**, 1307, p. 517; 1310, p. 516. **Lid of box**, 1882, p. 717. **Palette**, 8042, p. 773. **Ring**, 1785, p. 717. **Shrine**, 1624, p. 874. **Staff**, 1284, p. 717. **Vessel**, 20366, p. 874.

WEST BERLIN

Statues, 1106, p. 494; 1363, p. 517; 21839, p. 721; 22585, p. 721. **Stela**, 9427, p. 871.

Blocks, 4-8/63, p. 751; 3/65, p. 694; 5/70, p. 646; 39/66, p. 843.

Head-rests, 1309, p. 517; 1312, p. 517. **Model boats**, 1232, p. 517; 1289, p. 517; **kitchen**, 1366, p. 517; **models**, 1364-5, p. 517. **Tiles**, 1239, p. 400. **Chalice**, 4563, p. 875.

BERTHOUD (BURGDORF), Sammlung für Völkerkunde

Lintel, 7613, p. 892.

BIRMINGHAM, City Mus. and Art Gallery

Sphinx, 65.71, p. 823. **Statue-base**, 460.69, p. 823. **False-door**, 569.69, p. 506. **Wooden panel**, 442.69, p. 824.

BOLOGNA, Museo Civico

Statue, 328, p. 720. **Stelae**, 1901, pp. 734-5; 1946, p. 815.

Blocks, etc., 1869, p. 656; 1885-7, p. 656; 1888-9, p. 657; 1891-2, p. 751; 1894, p. 701; 1913, p. 715; 1944, p. 664.

BOLTON, Mus. and Art Gallery

Statue, A-76.1969, p. 822.

BONN, Ägyptologisches Seminar der Universität

Block, 118, p. 579.

BOSTON, Mus. of Fine Arts

Statues, 04.1749, p. 818; 24.605-8, p. 566; 29.730, p. 838; 29.731, p. 861; 47.1455, p. 647.

Stela, 25.635, p. 572. **Niche with false-door**, 24.593, p. 540.

Chapels, 04.1761 and 07.1005, pp. 467-8; 04.1760 and 1971.296, p. 454.

Blocks, etc.

| <i>No.</i> | <i>Page</i> |
|------------|-------------|
| 09.641 | 831 |
| 10.650 | 840 |
| 24.594 | 751 |
| 24.981 | 573 |
| 34.50 | 572 |
| 63.489 | 443 |
| 1973.483 | 572 |
| 1974.315 | 555 |
| 1974.468 | 701 |
| 1975.702 | 752 |

Box, 49.493, p. 770. **Lid of ushabti-coffin**, 1977.717, *see* Addenda.

BRISTOL, City Mus.

Statues, H 395, p. 848; H 799, p. 855. **Stelae**, H 2218A, p. 834; H 2218B, p. 833. **Column-fragments**, H 647, p. 872; H 648, p. 830; H 649, p. 872. **Blocks**, H 3568-9, p. 854.

BROOKLYN Mus.

Statues

| <i>No.</i> | <i>Page</i> |
|------------|-------------|
| 16.80 | 827 |
| 37.17E | 691 |
| 37.20E | 691 |
| 37.21-3E | 721 |
| 37.125E | 721 |
| 37.267E | 721 |
| 37.353 | 867 |
| 37.400E | 827 |
| 37.595E | 722 |
| 37.1509E | 828 |
| 37.1512E | 721 |
| 37.1920E | 851 |
| 49.215 | 697 |
| 50.77 | 647 |
| 51.1 | 647 |
| 53.222 | 647 |
| 57.42 | 868 |
| 58.30 | 868 |

Stelae

| <i>No.</i> | <i>Page</i> |
|------------|-------------|
| 37.33E | 735 |
| 37.46E | 716 |
| 37.107E | 735 |
| 37.1345-7E | 735 |
| 37.1353E | 735 |
| 37.1486E | 735 |

Blocks

| <i>No.</i> | <i>Page</i> |
|------------|-------------|
| 30.136 | 695 |
| 32.103 | 657 |
| 35.1315 | 715 |
| 36.261 | 752 |
| 37.25-8E | 452 |

| No. | Page | CG No. | Page |
|--|----------------|--------|---------|
| 37.31E | 752 | 23 | 723 |
| 37.39E | 716 | 25 | 700 |
| 37.1355E | 829 | 26 | 450 |
| 37.1487E | 752 | 27 | 457 |
| 37.1504-5E | 752 | 28 | 464 |
| 37.1513E | 752 | 29 | 458 |
| 47.120.1 | 752 | 30-1 | 581 |
| 56.152 | 874 | 32 | 724 |
| 57.178 | 453 | 33-4 | 459-60 |
| 61.165 | 752 | 35 | 500 |
| 64.147 | 492 | 36 | 499-500 |
| 71.10.1 | 752 | 37 | 723 |
| L76.11.2 | 695 note 1 and | 38-42 | 842 |
| (now 79.176) | Addenda | 44 | 690 |
| | | 45 | 598 |
| Coffin , 37.1521E, p. 763. Offering-tables , | | 47 | 598 |
| 37.1495-7E, p. 768. Canopic-jars , 48.30.1-4, | | 48 | 489 |
| p. 666. Head-rest , 37.440E, p. 774. Model | | 49 | 724 |
| axe-handle , 37.280E, p. 829. Offering- | | 51 | 480 |
| stands , 37.18-19E, p. 692. Ointment-jars , | | 53 | 462 |
| 49.52.1-7, p. 875. Shrines , 37.258-60E, | | 54 | 464 |
| p. 825; 37.1391E, p. 774. Tablets from | | 55 | 723 |
| foundation deposit , 37.465E, p. 829. Toilet- | | 56 | 457 |
| box , 37.600E, p. 770. Vases , 37.61E, p. 423; | | 57 | 724 |
| 37.69E, p. 431; 37.70E, p. 423; 37.76E, p. 421. | | 58 | 585 |
| BRUSSELS, Musées Royaux d'Art et d'Histoire | | 59 | 724 |
| Statues , E.2147, p. 818; E.4064, p. 839; | | 61 | 468 |
| E.4618, p. 839; E.7215, p. 722; E.7333, p. 865. | | 62 | 586 |
| False-doors and stelae , E.1835, p. 735; | | 64 | 489 |
| E.3468, p. 815; E.4498, p. 834; E.4499, | | 65-6 | 468 |
| p. 833; E.5268, p. 502; E.5270-1, p. 502; | | 67 | 505 |
| E.6303, p. 686; E.7429, p. 735; unnumbered, | | 69 | 581 |
| p. 834 | | 70-5 | 691 |
| Blocks , E.2383, p. 423; E.3053-5, p. 752; | | 76 | 478 |
| E.3056, p. 753; E.4491, p. 872; E.4979, p. 854; | | 77 | 464 |
| E.5036, p. 830; E.5297, p. 834; E.7297, p. 484; | | 78 | 724 |
| E.7546, p. 835; E.7559, p. 752; E.7636, p. 850. | | 81 | 464 |
| Tomb-chapel , E.2465, p. 583. Burial cham- | | 83 | 464 |
| ber , E.2243, p. 694. | | 84 | 724 |
| Canopic-jar , E.5901, p. 665. Clay statuettes | | 85 | 505 |
| with execration-texts , E.7440-94, 7607-14, | | 87-8 | 585 |
| and unnumbered, p. 549. Column , E.4987, | | 89 | 451 |
| p. 849. | | 92 | 724 |
| BRYN ATHYN (Pa.), Mus. of the Academy of the | | 93 | 465 |
| New Church | | 94 | 581 |
| Sarcophagus-fragment , see Addenda. | | 95 | 450 |
| BUDAPEST, Szépművészeti Múzeum | | 96 | 458 |
| Statues , 51.2050, p. 785; 60.17, p. 864. | | 97 | 480 |
| CAIRO, Egyptian Mus. | | 98 | 724 |
| Statues | | 99 | 722 |
| | | 100 | 465 |
| | | 101 | 724 |
| | | 102 | 489 |
| | | 103 | 581 |
| | | 104 | 722 |
| | | 105-6 | 457 |
| CG No. | Page | 107 | 480 |
| 1 | 864 | 108 | 488 |
| 7 | 722 | 110 | 478 |
| 8 | 724 | 111-12 | 464 |
| 18, 19 | 462 | 113 | 585 |
| 20 | 477-8 | 114 | 479 |
| 21 | 584 | 115 | 690 |
| 22 | 457 | | |

CAIRO, Statues (cont.):

| <i>CG No.</i> | <i>Page</i> | <i>CG No.</i> | <i>Page</i> |
|---------------|-------------|---------------|-------------|
| | | 292 | 725 |
| 116 | 479 | 303 | 480 |
| 117 | 725 | 304 | 722 |
| 118 | 479 | 305 | 478 |
| 119 | 478 | 309 | 722 |
| 120 | 699 | 312 | 480 |
| 121 | 725 | 313 | 478 |
| 123 | 452 | 314 | 723 |
| 127 | 480 | 321-3 | 581 |
| 129 | 690 | 329 | 725 |
| 130 | 480 | 368 | 465 |
| 131 | 722 | 369 | 723 |
| 132 | 724 | 371 | 724 |
| 133 | 584 | 372 | 505 |
| 134 | 724 | 376 | 722 |
| 136 | 723 | 377 | 468 |
| 137 | 724 | 387 | 847 |
| 143 | 463 | 410 | 847 |
| 144 | 722 | 452 | 725 |
| 145 | 723 | 503 | 893 |
| 151 | 451 | 504 | 892 |
| 154 | 483 | 505-6 | 893 |
| 155 | 724 | 507-8 | 898 |
| 156 | 582 | 509-12 | 893 |
| 157 | 584 | 513 | 899 |
| 160-1 | 724 | 514 | 893 |
| 162 | 483 | 515 | 887 |
| 163-4 | 480 | 516-17 | 893 |
| 165-6 | 724 | 518 | 899 |
| 167 | 725 | 519 | 890 |
| 168-9 | 724 | 526 | 725 |
| 170 | 581 | 547 | 865 |
| 171 | 489 | 554 | 835 |
| 172 | 480 | 595 | 868 |
| 174 | 581 | 597 | 726 |
| 178 | 581 | 604 | 726 |
| 181 | 468 | 606 | 726 |
| 182-5 | 480 | 628 | 726 |
| 186 | 457 | 630 | 838 |
| 187-8 | 480 | 641 | 863 |
| 190 | 698 | 642 | 667 |
| 191 | 723 | 643-4 | 832 |
| 192 | 480 | 653 | 861 |
| 194 | 480 | 655 | 837 |
| 196 | 723 | 659 | 866 |
| 201 | 723 | 666 | 867 |
| 204 | 724 | 667 | 727 |
| 205 | 457 | 671 | 848 |
| 206 | 723 | 673 | 848 |
| 207 | 464 | 681 | 864 |
| 208 | 724 | 682 | 867 |
| 211 | 478 | 683 | 818 |
| 212 | 458 | 685 | 778 |
| 214 | 480 | 696 | 868 |
| 259 | 888 | 713 | 707 |
| 263 | 581 | 726 | 867 |
| 264 | 725 | 727 | 868 |
| 265-6 | 581 | 731 | 727 |
| 268 | 722 | 741 | 866 |
| 269 | 725 | 763 | 703 |
| 270 | 722 | 784 | 670 |
| 272 | 478 | 798-9 | 726 |
| 284-5 | 581 | 801 | 726 |

Objects in Museums

997

| <i>CG No.</i> | <i>Page</i> | <i>JE No.</i> | <i>Page</i> |
|---------------------------------|-------------|---------------|-----------------|
| 803 | 725 | 36728 | 866 |
| 804-6 | 726 | 37647 | 868 |
| 807 | 861 | 38561 | 562 |
| 808 | 868 | 39103 | 562 |
| 812 | 725 | 39143 | 560 |
| 827 | 725 | 39149 | 561 and Addenda |
| 828 | 897 | 39150-3 | 560 |
| 850 | 667 | 39158 | 562 and Addenda |
| 870 | 838 | 40032 | 394 |
| 871 | 825 | 40037 | 496 |
| 888 | 839 | 40047 | 394 |
| 915 | 848 | 40431 | 864 |
| 999 | 613 | 41532 | 714 |
| 1024-5 | 778 | 41642 | 866 |
| 1034 | 707 | 44137 | 542 |
| 1052 | 864 | 44173-4 | 542 |
| 1058 | 613 | 44673 | 865 |
| 1085 | 862 | 44884 | 556 |
| 1090 | 865 | 45103 | 556 |
| 1105 | 666 | 45322 | 828 |
| 1106 | 839 | 45547 | 857 |
| 1159 | 888 | 46416 | 857 |
| 1163 | 889 | 47036 | 544 |
| 1169 | 848 | 47758-60 | 511 |
| 1174 | 851 | 47774 | 540 |
| 1175 | 869 | 47775 | 537 |
| 1193-6 | 778 | 47789 | 556 |
| 1206 | 864 | 48857-8 | 550 |
| 1210 | 848 | 49119 | 680 |
| 1211 | 835 | 49158 | 414 |
| 1212 | 848 | 49371 | 566 |
| 1249 | 898 | 49613 | 407 |
| 1251 | 725 | 49889 | 407 |
| 1252-4 | 726 | 49889a-g | 407 |
| 1293 | 863 | 50616 | 429 |
| 38104 | 835 | 51170 | 429 |
| 38233 | 849 | 51480-2 | 429 |
| 38236 | 849 | 51729 | 428 |
| 38358 | 670 | 51730-1 | 429 |
| 38368 | 819 | 51738 | 632 |
| 38411 | 819 | 51956-7 | 688 |
| 38429-30 | 833 | 52081 | 632 |
| 38432 | 828 | 52160-2 | 434 |
| 38884 | 670 | 52501 | 397-8 |
| 39147 | 819 | 52564-5 | 682 |
| 39220 | 652 | 53668 | 435 |
| 57001 | 843 | 53670 | 429 |
| | | 55032 | 852 |
| <i>JE No.</i> | | 58375 | 686 |
| 4404 | 827 | 58377 | 686 |
| 8388 | 724 | 59631 | 683 |
| 20830 | 525 | 60487 | 407 |
| 27851 (CG 57001) | 843 | 63110 | 685 |
| 29878 (now New York, M.M.A.) | 866 | 65907 | 724 |
| | | 67369 | 543 |
| 30139 | 869 | 67878 | 857 |
| 33255 | 553 | 71897 | 838 |
| 33262 | 862 | 71967-9 | 592 |
| 33266 | 862 | 72379-80 | 598 |
| 35204 | 722 | 86758 | 842 |
| 35312 | 581 | 88575-82 | 610 |
| 35313 | 725 | 89046 | 709 |
| 35351 | 868 | 89378 | 698 |

CAIRO, Statues (cont.):

| <i>JE No.</i> | <i>Page</i> | <i>CG No.</i> | <i>Page</i> |
|--|--------------------|---------------|-------------|
| 89384-5 | 698 | 1422 | 736 |
| 89599-89601 | 611 | 1423 | 578 |
| 89607 | 779 | 1424 | 458 |
| 91112 | 823 | 1425 | 736 |
| 91113-16 | 822 | 1426-30 | 438 |
| 91117 | 823 | 1436 | 468 |
| 91118 | 821 | 1444 | 611 |
| 91301 | 826 | 1445 | 698 |
| 91303-4 | 826 | 1446-7 | 736 |
| 91459 | 825 | 1448 | 492 |
| 91915 | 821 | 1453 | 689 |
| 91917 | 505 | 1455 | 691 |
| 93164 | 633 | 1456 | 692 |
| 93165-6 | 632 | 1461 | 468 |
| 93167 | <i>see Addenda</i> | 1464-5 | 465 |
| 93168-74 | 638 | 1467 | 463 |
| | | 1478 | 897 |
| <i>Temp. No.</i> | | 1481 | 897 |
| 23.7.17.17 | 496 | 1482 | 482 |
| 10.4.22.5 | 725 | 1483 | 586 |
| 8.6.24.10 | 553 | 1484 | 581 |
| 24.6.25.4 | 886 | 1485 | 481 |
| 18.2.26.5 | 415 | 1486 | 897 |
| 13.4.28.9 | 687 | 1488 | 886 |
| 16.9.30.12 | 852 | 1490 | 585 |
| 31.12.38.1 | 863 | 1506 | 612 |
| | | 1508 | 735 |
| <i>Number?</i> Pp. 449, 777, 826. | | 1509-10 | 483 |
| | | 1511 | 608 |
| Trial-pieces , CG 1185, p. 828; CG 33331-3, p. 828; CG 33348, p. 828; CG 33350-3, p. 828; CG 33356, p. 828; 33358-64, p. 828; No. ?, p. 828. | | 1513 | 736 |
| | | 1515 | 693 |
| | | 1516 | 586 |
| | | 1523 | 674 |
| | | 1524 | 736 |
| | | 1527 | 736 |
| | | 1528 | 451 |
| | | 1563 | 693 |
| | | 1564 | 484 |
| | | 1565 | 460 |
| | | 1571 | 545 |
| | | 1628 | 451 |
| | | 1665 | 544 |
| | | 1668 | 451 |
| | | 1672 | 890 |
| | | 1680 | 586 |
| | | 1694 | 465 |
| | | 1709 | 463 |
| | | 1715-16 | 736 |
| | | 1729 | 451 |
| | | 1756 | 463 |
| | | 1783 | 891 |
| | | 1785 | 891 |
| | | 9402 | 862 |
| | | 9405 | 862 |
| | | 9411 | 851 |
| | | 20528 | 898 |
| | | 22137 | 738 |
| | | 22161 | 828 |
| | | 22179 | 738 |
| | | 22189 | 862 |
| | | 31082 | 872 |
| | | 31086 | 815 |
| | | 31088 | 862 |

False-doors and stelae

| <i>CG No.</i> | <i>Page</i> |
|---------------|-------------|
| 1377-8 | 490 |
| 1379 | 482 |
| 1380 | 450 |
| 1381-3 | 890 |
| 1384 | 490 |
| 1385 | 449 |
| 1386-7 | 450 |
| 1388 | 501 |
| 1389 | 894 |
| 1390 | 893 |
| 1391 | 736 |
| 1392 | 489 |
| 1393 | 892 |
| 1394 | 736 |
| 1395 | 898 |
| 1397-8 | 736 |
| 1399 | 689 |
| 1400 | 736 |
| 1409 | 700 |
| 1410 | 698 |
| 1412 | 736 |
| 1413 | 506 |
| 1414 | 697 |
| 1415 | 484 |
| 1416 | 697 |
| 1417 | 483 |
| 1420 | 468 |

Objects in Museums

999

| <i>CG No.</i> | <i>Page</i> | <i>YE No.</i> | <i>Page</i> |
|-------------------------|-------------|-------------------------------------|-------------|
| 31099 | 738 | 36808, <i>see</i> CG 57168 | |
| 31103 | 738 | 36853 | 559 |
| 31136 | 738 | 36854-5 | 395 |
| 31157 | 816 | 36856 | 559 |
| 34020 | 849 | 37494 | 870 |
| 34049 | 736 | 37953 | 895 |
| 34050 | 737 | 38539 | 737 |
| 34054 | 737 | 38542 | 563-4 |
| 34055 | 557 | 38552, <i>see</i> CG 57211 | |
| 34098 | 737 | 38553, <i>see</i> CG 57202 | |
| 34182 | 737 | 38554, <i>see</i> CG 57197 | |
| 34186 | 870 | 38555, <i>see</i> CG 57206 | |
| 34188 | 395 | 38556 (now in Port Sa'id) | 562 |
| 50042 | 801 | 38557, <i>see</i> CG 57212 | |
| 57120-I | 894 | 38558, <i>see</i> CG 57210 | |
| 57122 | 892 | 38559, <i>see</i> CG 57209 | |
| 57124 | 565 | 38560 | 563 |
| 57126 | 481 | 38563-4, <i>see</i> CG 57121, 57120 | |
| 57136 | 482 | 39102 | 562 |
| 57138 | 482 | 39140 | 559 |
| 57140-I | 482 | 39865 | 496 |
| 57143 | 895 | 40043 | 816 |
| 57168 | 652 | 40693 | 667 |
| 57173 | 581 | 41570 | 688 |
| 57180 | 505 | 43204 | 815 |
| 57188 | 736 | 44135 | 436 |
| 57190 | 598 | 44722 | 555 |
| 57197 | 562 | 45044 | 842 |
| 57202 | 563 | 45530 | 858 |
| 57206 | 563 | 45535 | 858 |
| 57209-10 | 563 | 45539 | 858 |
| 57211 | 562 | 45543 | 858 |
| 57212 | 563 | 45548-50 | 858 |
| | | 45552 | 858 |
| | | 45557 | 858 |
| | | 45567 | 858 |
| | | 48845 | 665 |
| | | 49060 | 819 |
| | | 49804 | 686 |
| | | 49805 | 685 |
| | | 51733 | 687 |
| | | 52508-9 | 407 |
| | | 54155 | 675 |
| | | 55618 | 549 |
| | | 59158 | 568 |
| | | 66149 | 688 |
| | | 68923 | 443 |
| | | 72201 | 637 |
| | | 86763 | 846 |
| | | 89289 | 882 |
| | | 89290 | 879 |
| | | 91387 | 826 |
| | | | |
| <i>YE No.</i> | | <i>Temp. No.</i> | |
| 3299 | 737 | 9.2.15.1 | 395 |
| 4889 | 816 | 18.12.19.1 | 737 |
| 8778 | 737 | 22.1.21.1 | 737 |
| 8781 | 737 | 10.6.24.8 | 552 |
| 10079 | 707 | 19.11.24.20 | 688 |
| 15037 | 816 | 2.12.24.3 | 779 |
| 15045-6 | 463 | 16.3.25.12 | 849 |
| 15050 | 468 | 27.3.25.17 | 555 |
| 15115 | 667 | 22.5.25.2 | 828 |
| 15139 | 452 | | |
| 15152 | 689 | | |
| 15159 | 479 | | |
| 15160 | 482 | | |
| 18922 | 737 | | |
| 18924 (probably) | 666 | | |
| 20014 | 816 | | |
| 22110 | 738 | | |
| 27322 | 871 | | |
| 27958 | 667 | | |
| 28569 | 737 | | |
| 28582 | 839 | | |
| 28684 | 738 | | |
| 30951-2 | 888 | | |
| 34208 | 875 | | |
| 34542 | 553 | | |
| 34558 | 843 | | |
| 34741 (35182) | 870 | | |
| 35182, <i>see</i> 34741 | | | |

CAIRO, False-doors and stelae (*cont.*):

| <i>Temp. No.</i> | <i>Page</i> |
|---|-------------|
| 31.3.33.40-3 | 407 |
| <i>Number?</i> Pp. 438, 450, 736-7, 788, 816, 816, 849, 858. | |

Blocks, etc.

| <i>CG No.</i> | <i>Page</i> |
|---------------|-------------|
| 1396 | 496 |
| 1418-19 | 460 |
| 1421 | 468 |
| 1434 | 753 |
| 1437-8 | 753 |
| 1440 | 689 |
| 1468-77 | 896 |
| 1487 | 892 |
| 1489 | 892 |
| 1491-2 | 585 |
| 1494 | 491 |
| 1525 | 674 |
| 1530 | 506 |
| 1531 | 753 |
| 1533 | 580 |
| 1534 | 486 |
| 1535 | 753 |
| 1540 | 506 |
| 1541 | 484 |
| 1542 | 586 |
| 1543 | 481 |
| 1544 | 753 |
| 1545 | 586 |
| 1546-7 | 753 |
| 1553 | 586 |
| 1554 | 582 |
| 1555 | 482 |
| 1556 | 484 |
| 1557 | 482 |
| 1558 | 580 |
| 1560-1 | 753 |
| 1562 | 754 |
| 1566-7 | 693 |
| 1569-70 | 456 |
| 1599 | 506 |
| 1630 | 754 |
| 1634 | 674 |
| 1671 | 482 |
| 1673-4 | 456 |
| 1676 | 586 |
| 1684 | 612 |
| 1687 | 674 |
| 1688 | 611 |
| 1689-90 | 612 |
| 1691 | 693 |
| 1696 | 754 |
| 1697 | 613 |
| 1701 | 753 |
| 1702 | 456 |
| 1704-5 | 423 |
| 1706 | 430 |
| 1711 | 693 |
| 1718 | 612 |
| 1720 | 754 |
| 1721 | 506 |
| 1732-3 | 611 |

CG No.

| | |
|------------------|-----|
| 1734 | 486 |
| 1737 | 450 |
| 1739 | 482 |
| 1769-82 | 891 |
| 1784 | 892 |
| 1786 | 891 |
| 57119 | 421 |
| 57129 (probably) | 450 |
| 57130 | 754 |
| 57142 | 895 |
| 57160-1 | 693 |
| 57182 | 754 |

JE No.

| | |
|----------------------------|----------|
| 4872 | 754 |
| 4873-5 | 714 |
| 8374-80 | 665 |
| 8380 bis | 665 |
| 8380 ter | 665 |
| 8381-2 | 665 |
| 8383 | 755 |
| 10976-8 | 852 |
| 11332-4 | 657 |
| 17803 | 753 |
| 30174 | 872 |
| 33258 | 556 |
| 36585, <i>see</i> CG 57182 | |
| 38070, <i>see</i> CG 57130 | |
| 38576 (<i>also</i> 48837) | 872 |
| 39133 | 421 |
| 39228 | 564 |
| 39734-5 | 874 |
| 39861-3 | 394 |
| 39866 | 499 |
| 39922-4 | 394 |
| 40016 | 704 |
| 40027 | 754 |
| 40028 | 393 |
| 40029 | 421 |
| 40033 | 853 |
| 41436 | 830 |
| 41572 | 654 |
| 42002 | 450 |
| 43274 | 662 |
| 43275 | 668, 669 |
| 43276 | 667, 668 |
| 43277 | 667, 668 |
| 43278 | 755 |
| 43972 | 753 |
| 44859-60 | 874 |
| 44924 | 555 |
| 44925-6 | 557 |
| 44927 | 755 |
| 44928-30 | 557 |
| 44932 | 526 |
| 45239 | 496 |
| 45249 | 421 |
| 45568-70 | 858 |
| 46189 | 862 |
| 46190-1 | 669 |
| 46915 | 873 |
| 48837, <i>see</i> 38576 | |
| 49681 | 432 |

| | |
|---------------|-------------|
| <i>JE No.</i> | <i>Page</i> |
| 51732 | 432 |
| 51958-9 | 882 |
| 51978 | 882 |
| 51979 | 688 |
| 52542 | 716 |
| 55937 | 456 |
| 56370 | 431 |
| 70149 | 441 |
| 89660 | 754 |
| 91104 | 824 |

| | |
|------------------|-------------|
| <i>Temp. No.</i> | <i>Page</i> |
| 22.11.14.17-19 | 835 |
| 28.5.24.8 | 719 |
| 10.6.24.12 | 754 |
| 12.6.24.6 | 754 |
| 14.6.24.24 | 669 |
| 14.6.24.25 | 667 |
| 14.6.24.29 | 707 |
| 17.6.24.1, 2 | 669 |
| 17.6.24.4 | 668 |
| 17.6.24.5 | 667 |
| 17.6.24.7-10 | 668 |
| 17.6.24.11 | 669 |
| 17.6.24.13 | 555 |
| 19.6.24.1 | 662 |
| 19.6.24.3 | 669 |
| 19.6.24.4-5 | 668 |
| 19.6.24.7 | 668 |
| 19.6.24.10 | 662 |
| 19.6.24.11 | 668 |
| 19.6.24.13 | 668 |
| 19.6.24.14 | 669 |
| 19.6.24.15-18 | 667 |
| 21.6.24.12 | 555 |
| 21.6.24.16 | 555 |
| 25.6.24.1 | 669 |
| 25.6.24.2 | 668 |
| 25.6.24.6 | 755 |
| 25.6.24.7 | 707 |
| 25.6.24.8 | 755 |
| 27.6.24.2 | 755 |
| 27.6.24.10 | 701 |
| 29.6.24.13 | 662 |
| 1.7.24.2 | 668 |
| 1.7.24.5 | 755 |
| 1.7.24.6 | 665 |
| 1.7.24.8-10 | 668 |
| 3.7.24.2 | 557 |
| 3.7.24.11 | 850 |
| 3.7.24.13 | 707 |
| 5.7.24.1 | 669 |
| 5.7.24.4 | 669 |
| 5.7.24.11 | 553 |
| 5.7.24.15 | 553 |
| 19.11.24.17 | 489 |
| 19.11.24.19 | 489 |
| 17.5.25.1 | 555 |
| 17.5.25.8 | 554 |
| 17.6.25.1 | 553 |
| 8.11.26.4 | 755 |
| 24.5.28.1-4 | 898 |
| 6.9.32.1 | 398 |

Number? Pp. 393, 398, 428, 438, 589, 668, 668, 850, 862, 874.

Blocks with graffiti, CG 25377, p. 882; CG 25378-9, p. 885; CG 25380, p. 887.

Trial-pieces, CG 33413, 33425, 33437, 33443-4, 33489, p. 829.

Tomb burial-chambers, CG 1572, p. 673; JE 88131, p. 846. **Tomb-walls**, CG 1536-7, p. 671; 34516, p. 666; 57192, p. 692. **Part of tomb-chapel**, Temp. Nos. 25.1.15.7 and 17.6.25.5, p. 554; 22.5.25.1, p. 554.

Sarcophagi and coffins

| | |
|---------------|-------------|
| <i>CG No.</i> | <i>Page</i> |
| 28034-6 | 673 |
| 28100 | 888 |
| 28101 | 886 |
| 28102-3 | 885 |
| 28104 | 889 |
| 28105 | 899 |
| 28106 | 888 |
| 28108 | 552 |
| 28121 | 615 |
| 29301 | 612 |
| 29302 | 613 |
| 29303-5 | 507 |
| 29306-7 | 504 |
| 29308 | 505 |
| 29310 | 764 |
| 29311 | 763 |
| 29312 | 670 |
| 29323 | 764 |

| | |
|---------------|-----------------|
| <i>JE No.</i> | <i>Page</i> |
| 4739-40 | 612 |
| 6400 | 612 |
| 6401 | 764 |
| 17431 | 612 |
| 34648 | 649 |
| 34649 | 671 |
| 35156 | 648 |
| 35265 | 763 |
| 39052 | 561 and Addenda |
| 39053-4 | 560 |
| 39114 | 560 |
| 49531-2 | 764 |
| 52012 | 679 |
| 59128 | 847 |
| 65908 | 676 |
| 87077 | 645 |

| | |
|------------------------|-------------|
| <i>Temp. No.</i> | <i>Page</i> |
| 21.11.14.6 | 566 |
| 11.11.20.8 | 549 |
| 3.1.21.12, see JE 6401 | |
| 13.1.21.1 | 763 |
| 13.1.21.2 | 764 |
| 20.1.21.1, 2 | 507 |
| 22.1.21.3, 4 | 764 |
| 22.1.21.5, 6 | 612 |
| 23.1.21.7, 8 | 612 |
| 3.3.21.1 | 612 |

| | | |
|---|--|-------------|
| CAIRO, Sarcophagi and coffins (cont.): | | |
| <i>Temp. No.</i> | | <i>Page</i> |
| 3.3.21.8 | | 764 |
| 19.8.23.1 | | 540 |
| 18.1.27.2 | | 549 |
| 18.1.27.3 | | 550 |

Offering-tables and basins

| | | |
|---------------------------|--|-------------|
| <i>CG No.</i> | | <i>Page</i> |
| 1304 | | 459 |
| 1305 | | 691 |
| 1306 | | 449 |
| 1324 | | 768 |
| 1325 | | 894 |
| 1326 | | 458 |
| 1327 | | 481 |
| 1328 | | 468 |
| 1330 | | 898 |
| 1331 | | 768 |
| 1332 | | 605 |
| 1336 | | 465 |
| 1343 | | 768 |
| 1344 | | 688 |
| 1346 | | 768 |
| 1348 | | 768 |
| 1350 | | 768 |
| 1352 | | 768 |
| 1355 | | 674 |
| 1356 | | 768 |
| 1359 | | 449 |
| 1363 | | 768 |
| 1365-6 | | 768 |
| 1367 | | 579 |
| 1368 | | 525 |
| 1369 | | 768 |
| 1370 | | 485 |
| 1371 | | 693 |
| 1373 | | 507 |
| 1375 | | 894 |
| 20529 | | 898 |
| 23031 | | 571 |
| 23079 | | 557 |
| 23088 | | 830 |
| 23094 | | 556 |
| 23114 | | 670 |
| 57014-18 | | 565 |
| <i>JE No.</i> | | |
| 15214 | | 579 |
| 19179 | | 768 |
| 30953 | | 888 |
| 37951 | | 898 |
| 38426-30, see CG 57014-18 | | |
| 43881 | | 768 |
| 44128 | | 437 |
| 44131 | | 437 |
| 44147 | | 440 |
| 55618 | | 549 |
| 63195-6 | | 534 |
| 72202 | | 637 |
| 89379-82 | | 698 |
| 89602 | | 610 |
| 91143 | | 824 |
| 91518-19 | | 824 |

| | |
|-----------------------|-------------|
| <i>JE No.</i> | <i>Page</i> |
| 91916 | 824 |
| <i>Number? P. 862</i> | |

Aegis, Temp. No. 30.5.26.1, p. 820. **Altar (?)**, JE 52519, p. 407. **Gold band**, CG 53800, p. 648; **silver gilt bands and mask**, CG 53770-3, p. 503; 53778, p. 503; **gold band and mask**, CG 53668, p. 650. **Gold belt**, JE 87078, p. 645. **Block stand**, JE 86757, p. 842. **Boats**, CG 4925-6, p. 885. **Bolt**, JE 37765, p. 863. **Bowls**, JE 63197, p. 534; Nos. ?, p. 442.

Boxes, CG 1765, p. 770; 18642, p. 886; 18651, p. 886; 18721, p. 889; 44706 (JE 32744), p. 557; JE 69498-501, p. 401; No. ?, p. 441.

Bracelet slides, CG 52026-7, p. 884.

Canopic-boxes, JE 39107, p. 560; Temp. No. 2.3.15.2, p. 549; 14.3.15.11, p. 550.

Canopic-chests, CG 4048-9, p. 896; JE 51266, p. 888; 51268, p. 889.

Canopic-jars

| | |
|---------------|-------------|
| <i>CG No.</i> | <i>Page</i> |
| 4005-6 | 883 |
| 4007-10 | 889 |
| 4019-22 | 888 |
| 4089-92 | 671 |
| 4094-109 | 771 |
| 4122-5 | 771 |
| 4126-9 | 671 |
| 4130-5 | 770 |
| 4145-8 | 771 |
| 4153-60 | 770 |
| 4161-4 | 771 |
| 4170 | 771 |
| 4172-4 | 771 |
| 4208 | 771 |
| 4220-4 | 771 |
| 4266-9 | 565 |
| 4270-3 | 771 |
| 4288-9 | 770 |
| 4294-9 | 771 |
| 4308-10 | 670 |
| 4311 | 771 |
| 4322-3 | 771 |
| 4325-6 | 771 |
| 4330 | 770 |
| 4389-93 | 771 |

| | |
|---------------|-----|
| <i>JE No.</i> | |
| 34078 | 649 |
| 34162 | 648 |
| 34330 | 648 |
| 34679 | 650 |
| 35360 | 503 |
| 35781 | 588 |
| 35901 | 650 |
| 47031 bis | 525 |
| 47032 bis | 525 |
| 47785-6 | 525 |
| 54498 | 435 |

| | |
|---------------|-------------|
| <i>JE No.</i> | <i>Page</i> |
| 59175 | 888 |
| 86764 | 846 |
| 91520 | 826 |

| | |
|------------------|-----|
| <i>Temp. No.</i> | |
| 25.11.60.1-4 | 890 |

Cat sarcophagus, CG 5003, p. 851. **Granite chest**, CG 4046, p. 883. **Columns**, JE 35131, p. 420; 41525, p. 704; 56371-5, p. 434; Temp. No. 20.1.25.4, p. 873. **Column-capital**, No. ?, p. 855. **Cups**, JE 48885-6, p. 397; 58346-7, p. 432; No. ?, p. 441. **Cylinder-seals**, JE 45495, p. 875; 72209, p. 598; 72625, p. 542. **Dagger**, CG 52768, p. 552. **Death-mask**, No. ?, p. 395. **Decree**, JE 63398, p. 684. **Dish-fragment**, JE 49857, p. 681. **Disks**, JE 58342-5, p. 432; 70160, p. 441; 70164-5, p. 441. **Doorways**, CG 1552, p. 894; JE 45029, p. 857; Temp. No. 3.2.21.1 (now in Philadelphia), p. 857. **Doorwings**, CG 1568, p. 693; JE 47749, p. 543. **Draughts-board**, CG 68001, p. 559. **Drum (wooden) of doorway**, JE 44175, p. 542. **Dummy mummy of Apis-bull**, JE 91318, p. 825. **Embalming-tables**, CG 1321-2, p. 415. **Faience fragment**, JE 41293, p. 875. **Fan-handles**, JE 86161, p. 652; Temp. No. 6.4.23.12, p. 774. **Foundation deposit**, JE 35174, p. 842. **Head-rests**, CG 1792, p. 774; 1797, p. 699; JE 39155-6, p. 560; 52545, p. 677; 88559-60, p. 540. **Implements, etc.**, No. ?, p. 444. **Jackal-coffins**, CG 29760, p. 777; 29765, p. 777. **Labels**, JE 63346, p. 436; 70114-16, p. 441; JE 86172-5, p. 436; No. ?, p. 436. **Linen**, No. ?, p. 424.

Mace-heads, JE 39163, p. 395; 47225, p. 395; 49372-3, p. 395. **Measuring-vessel**, JE 86754, p. 842. **Mirrors**, CG 44075, p. 875; 44076-80, p. 831; JE 50280, p. 688.

Models, JE 39126, p. 561; 39129-32, p. 561; 39146-7, p. 561; 45319-21, p. 550; 45496, p. 550; 46765, p. 550; 46769-72, p. 550; 47929, p. 539; Temp. No. 4.3.23.1, p. 560; No. ?, p. 561 (two).

Model boats

| | |
|---------------|-------------|
| <i>CG No.</i> | <i>Page</i> |
| 4913 | 774 |
| 4915-17 | 774 |
| 4924 | 835 |
| 4930 | 835 |

| | |
|---------------|-----------------|
| <i>JE No.</i> | |
| 35920-2 | 650 |
| 39127-8 | 560 |
| 39144 | 560 |
| 39145 | 561 and Addenda |
| 45318 | 550 |
| 46766-8 | 550 |
| 56386-97 | 432 |
| 63183-94 | 541 |

Number ? P. 673.

Mummy-masks, etc., CG 28107, p. 888; 53779-80, p. 588; JE 52538, p. 682; 89386, p. 698; Temp. No. 11.12.25.18, p. 504; 20.12.25.1, p. 774.

Naos, CG 70035, p. 888. **Necklace-clasp**, CG 53834, p. 525. **Necklace-fragment**, CG 53839, p. 525.

Obelisks, CG 1308, p. 462; 1312, p. 462; 1315, p. 898; 17005, p. 774; 17006, p. 537; 17007-8, p. 548; JE 63404, p. 684.

Offering-stands, CG 1295, p. 689; 1296, p. 774; 1297, p. 689; 1298, p. 491; 1299, p. 479; 1300, p. 698; 1301, p. 491; 1302-3, p. 479.

Ointment-slabs, CG 1337, p. 582; 1338, p. 691; 1339, p. 698; 1340-2, p. 768; JE 47033, p. 515; 50674, p. 677; 59153-4, p. 397.

Palette, CG 69021, p. 557. **Panels**, JE 52021, p. 426; 52343, p. 426; 62950, p. 685. **Pectorals**, CG 52001, p. 883; 52002-3, p. 884. **Pendants**, CG 53247, p. 648; 53249, p. 648. **Pilaster-fragments**, JE 43272-3, p. 662. **Pillars**, CG 1550-1, p. 613; JE 15048 (probably), p. 463; 18928, p. 755; 43270, p. 668; 43271, p. 703; Temp. No. 20.1.25.5, p. 755; number ?, see Addenda. **Plaques**, JE 30082, p. 875; 35107, p. 831; 39148, p. 395; 39171, p. 559; 59119, p. 507; 92679, p. 416; Temp. Nos. 27.11.26.3, 4, p. 831. **Pyramidia**, CG 17109 (JE 8371), p. 770; JE 35133 (also JE 35745), p. 888; 41665, p. 553; 48841, p. 770; 53045, p. 435; 54855-6, p. 435; Temp. No. 7.11.24.1, p. 770. **Rudder**, CG 4927, p. 885.

Sealings

| | |
|------------------|-------------|
| <i>JE No.</i> | <i>Page</i> |
| 35584-8 | 613 |
| 35590-5 | 613 |
| 35598-619 | 613 |
| 44372 (probably) | 437 |
| 44373 | 439 |
| 44378 | 437 |
| 72205-6 | 598 |
| 91311 | 448 |

| | |
|------------------|-----|
| <i>Temp. No.</i> | |
| 24.12.23.4 | 437 |
| 24.12.23.5 | 436 |

Number ? P. 441 (twice).

Shrines, CG 70010, p. 874; JE 91103, p. 824. **Sickle**, JE 70204, p. 441. **Sistra**, CG 69324, p. 863; 69334, p. 875. **Sled**, CG 4928, p. 885. **Sphinx from furniture**, JE 91111, p. 824. **Clay statuettes with excretion-texts**, JE 70221, p. 549. **Sticks and clubs**, Temp. Nos. 20.3.31.7-10, p. 561 and Addenda. **Stopper**, JE 72204, p. 598.

Vessels (vases, jars, etc.) and lids

| | |
|---------------|-------------|
| <i>CG No.</i> | <i>Page</i> |
| 4028-9 | 889 |
| 5019-22 | 430 |
| 18037 | 820 |

CAIRO, Vessels and lids (cont.):

| <i>CG No.</i> | <i>Page</i> |
|---------------|-------------|
| 18451 | 773 |
| 18489 | 820 |
| 18643-50 | 886 |
| 18652-9 | 886 |
| 18661-77 | 886 |
| 18722-8 | 889 |
| 18734 | 829 |
| 18790 | 773 |

| <i>JE No.</i> | <i>Page</i> |
|---------------|-------------|
| 40691 | 559 |
| 44367 | 439 |
| 45170 | 440 |
| 45179 | 437 |
| 45324-5 | 437 |
| 47037 | 537 |
| 47038 | 394 |
| 47050 | 525 |
| 49838 | 433 |
| 49841 | 433 |
| 50675 | 677 |
| 55254-6 | 402 |
| 55257 | 403 |
| 55258-9 | 402 |
| 55261-8 | 403 |
| 55269 | 404 |
| 55271-7 | 404 |
| 55278 | 403 |
| 55279-82 | 404 |
| 55283-4 | 403 |
| 55285-6 | 404 |
| 55287-8 | 403 |
| 55289 | 404 |
| 55291 | 405 |
| 55292 | 402 |
| 55293-4 | 403 |
| 57424 | 431 |
| 59139-40 | 404 |
| 59141 | 405 |
| 59142-4 | 403 |
| 59145-9 | 404 |
| 59151 | 403 |
| 62955 | 430 |
| 63237-8 | 397 |
| 64872 | 405 |
| 64887 | 403 |
| 64891 | 403 |
| 65413 | 403 |
| 65337-44 | 430 |
| 66159 | 405 |
| 87784 | 874 |
| 88221 | 403 |
| 88223-5 | 403 |
| 88235 | 402 |
| 88284 | 402 |
| 88309 | 402 |
| 88322 | 403 |
| 88343 | 403 |
| 88344-5 | 402 |
| 88355 | 403 |
| 88374 | 403 |
| 88397 | 403 |

| <i>JE No.</i> | <i>Page</i> |
|---------------|-------------|
| 88406 | 402 |
| 88418 | 403 |
| 88421 | 402 |

Number? P. 441 (twice).

Weights, CG 31651, p. 829; 31652, p. 875. **White Crown**, JE 91110, p. 824. **Writing board**, CG 25224, p. 557. **Zad-panel**, JE 68921, p. 401. **Zad-pillar**, JE 65061, p. 661 and Addenda.

CAMBRIDGE, Fitzwilliam Mus.

Statues, E.8.1913, p. 863; E.6.1969, p. 821; E.8.1969, p. 822; E.12.1969, p. 822; E.11.1971, p. 826.

Stelae, E.74.1911, p. 842; E.SS.37, p. 738.

Jamb, E.5.1909, p. 831. **Blocks**, E.63.1911, p. 854; E.75.1911, p. 854; E.19.1913, p. 850; E.59.1914, p. 850; E. 182.1939, p. 428; E.SS.2, 6, 7, 11, p. 423.

Offering-table, E.2.1969, p. 448. **Shrine door**, E.5.1969, p. 824.

CAMBRIDGE (Mass.), Fogg Art Mus., Harvard University

Blocks, 1934.17, 18, p. 694.

CHICAGO, Art Institute

Side-pieces of false-doors, 10.223-4 (now Or. Inst. 17361-2), p. 563; 10.225, p. 563; 10.229 (now Or. Inst. 17364), p. 564; 10.230 (now Or. Inst. 17365), p. 564; 10.232 (now Or. Inst. 17366), p. 564. **Blocks**, 10.228, p. 755; 92.246 (now Or. Inst. 17300), p. 707.

CHICAGO, Field Mus. of Natural History

False-doors and stelae, A.31297, p. 502; A.31309, p. 501; A.31652, p. 738; A.31690, p. 691; A.31711, p. 694.

Blocks, etc.

| <i>A. No.</i> | <i>Page</i> |
|---------------|-------------|
| 24448 | 616 |
| 31291-2 | 755 |
| 31299 | 691 |
| 31308 | 691 |
| 31707-8 | 692 |
| 31709-10 | 694 |
| 31728 | 692 |
| 31730 | 692 |
| ? | 589 |

Tomb-chapel, A.24450, p. 485.

Sarcophagus, A.105175, p. 505. **Boat**, A.31760, p. 885.

CHICAGO, Oriental Institute

Statue, 10744, p. 727.

Stelae, 9375, p. 816; 10490, p. 738; 10813, p. 738; 11049, p. 739; 13652, p. 407.

Side-pieces of false-doors, 17361-2, p. 563; 17364-6, p. 564.

Blocks, etc., 9160, p. 854; 9169, p. 850; 9170, p. 872; 10591, p. 658; 10810, p. 454; 10814, p. 677; 10815, p. 454; 14049, p. 423; 17300, p. 707.

Coffin, 12072, p. 570.

CINCINNATI (Ohio), Art Mus.

Blocks, 1971.28, p. 755; 1974.413, p. 433.
Canopic-jars, 1947.397-400, p. 773 and Addenda.

CLEVELAND (Ohio), Mus. of Art

Statue, 64.90, p. 697. **Blocks, etc.**, 30.136, p. 695; 30.734-7, p. 694; 30.738, p. 695; 64.91, p. 696.

COPENHAGEN, Nationalmuseet

Statue, AA.b.27, p. 727. **False-doors**, 5129, p. 456; AA.d.18, 19, p. 739. **Blocks**, 5491, p. 483; 15002, p. 756.

COPENHAGEN, Ny Carlsberg Glyptotek

Statues

| <i>Æ.I.N. No.</i> | <i>Page</i> |
|-------------------|-------------|
| 32 | 866 |
| 614 | 870 |
| 659 | 863 |
| 1047 | 855 |
| 1144 | 863 |
| 1384 | 869 |
| 1480 | 836 |
| 1483 | 836 |
| 1505 | 849 |
| 1626-7 | 538 |

False-doors and stelae

| <i>Æ.I.N. No.</i> | <i>Page</i> |
|-------------------|-----------------|
| 6, 7 | 449 |
| 8-12 | 739 |
| 15 | 739 |
| 22 | 739 |
| 134 | 871 |
| 896 | 739 |
| 897 | 870 |
| 942-3 | 739 |
| 1014-17 | 834 |
| 1438 | 698 and Addenda |
| 1516 | 849 |
| 1616 | 538 |

Blocks, etc.

| <i>Æ.I.N. No.</i> | <i>Page</i> |
|-------------------|-------------|
| 16,17 | 756 |
| 38 | 756 |
| 45 | 756 |
| 690 | 756 |
| 714-16 | 701 |
| 938-40 | 756 |
| 1012 | 853 |
| 1046 | 830 |
| 1048-50 | 830 |
| 1147 | 839 |
| 1148 | 850 |
| 1152 | 840 |

| <i>Æ.I.N. No.</i> | <i>Page</i> |
|-------------------|-------------|
| 1421 | 854 |
| 1446-8 | 756 |
| 1510 | 839 |
| 1511-12 | 851 |
| 1513 | 850 |

Tomb-chapel, Æ.I.N.1271, pp. 486-7.

Sarcophagus-fragment, Æ.I.N.48, p. 654;
coffin, Æ.I.N.1615, p. 538.

Offering-tables, Æ.I.N.1551, p. 769;
Æ.I.N.1554, p. 708; **basin**, Æ.I.N.1550,
p. 465.

Canopic-box, Æ.I.N.1623, p. 538. **Column-capital**, Æ.I.N.1045, p. 830. **Model boat**, Æ.I.N.1629, p. 539; **granary**, Æ.I.N.1630, p. 539; **models**, Æ.I.N.1628, p. 539; Æ.I.N.1631-4, p. 539. **Naos-fragments**, Æ.I.N.1382, p. 888.

COPENHAGEN, Thorwaldsen Mus.

Niche with statue, 349, p. 708. **Vessel**, 264, p. 713.

DAYTON (Ohio), Art Institute

Block, 72.49, p. 757.

DETROIT (Mich.), Institute of Arts

False-door, 57.58, p. 501. **Blocks**, 24.98, p. 757; 30.371, p. 695; 65.2, p. 872; 72.224, p. 625.

DRESDEN, Skulpturensammlung

Lintel, Inv. Aeg. 753, see Addenda.

DUBLIN, National Mus.

Statues, 1908.514, p. 833; 1908.516, p. 866.
Stelae, 1908.518-19, p. 834.

DUNDEE, Mus. and Art Gallery

False-door, 66.222, p. 891.

DURHAM, Gulbenkian Mus. of Oriental Art and Archaeology

Statue, N.511, p. 838. **Stela**, N.1965, p. 740.
Canopic-jars, N.1986-9, p. 772. **Vessel**, N.1379, p. 713.

EDINBURGH, Royal Scottish Mus.

Statues, 1969.80, p. 822; 1969.81, p. 821; 1971.130, p. 821; 1971.165, p. 823. **Stelae**, 1908.360-2, p. 833; 1908.363, p. 834. **Blocks**, 1910.154, p. 840; 1958.46, p. 695; 1961.438, p. 757. **Column-fragment**, 1908.364, p. 855. **Bronze corner of door**, 1910.155, p. 830. **Ivory inlay**, X.294.3, p. 831.

EVANSTON (Ill.), Hibbard Memorial Library

Block, 4, p. 854.

FLORENCE, Mus. Archeologico

Statue, 1790, p. 727.

False-doors and stelae

| <i>No.</i> | <i>Page</i> |
|------------|-------------|
| 2507 | 740 |

FLORENCE, False-doors and stelae (cont.):

| No. | Page |
|------|------|
| 2532 | 654 |
| 2537 | 712 |
| 2538 | 740 |
| 2541 | 871 |
| 2551 | 740 |
| 2554 | 490 |
| 2565 | 712 |
| 2567 | 702 |
| 2584 | 740 |
| 2589 | 740 |
| 2592 | 740 |

Blocks, 2557, p. 714; 2566, p. 658; 2581, p. 757; 2600-1, p. 655; 5412, p. 757. **Pillar**, 2607, p. 709.

Sarcophagus, 2182, p. 591. **Canopic-jars**, 2215-17, p. 772; 2226, p. 773; 2237, p. 772. **Jars**, 2338-9, p. 703. **Cubit-measure**, 3078, p. 703. **Model palette**, 3080, p. 703. **Pyramidion**, 2610, p. 702.

FRANKFURT-AM-MAIN, Liebieghaus

Block, 270, p. 757. **Canopic-jar**, X.11214, p. 771.

GENEVA, Musée d'Art et d'Histoire

Blocks, 19490-1, p. 695; 19627, p. 695.

GOTHA, Schlossmuseum

Block, 74 Ae, p. 492. **Sarcophagus-fragment**, 16 Ae, p. 764.

GRENOBLE, Musée de Peinture et de Sculpture

Stela, 14 [Inv. 1950], p. 816. **Coffin**, 74, p. 719.

HAGUE, THE, Gemeente Mus. voor Oude Kunst

Statue, 1952, p. 897. **Stela**, 1957, p. 717.

HAGUE, THE, Scheurleer Mus.

Dispersed.

False-doors and stelae, pp. 700, 716-17, 741, 777, 834. **Blocks**, pp. 484, 484, 484, 700, 700, 716-17 (six), 752, 758 (two), 758, 762, 850.

HAMBURG, Hamburgisches Mus. für Völkerkunde

Blocks, C.4055, p. 757; 1115.05, p. 757.

HAMBURG, Mus. für Kunst und Gewerbe

Block, 1924.123, p. 662.

HAMM, Städtisches Gustav Lübke-Mus.

Obelisk, Inv.5769, p. 678.

HANOVER, Kestner-Mus.

False-doors and stelae, 1935.200.46, p. 700; 1935.200.48, p. 741; 1935.200.199, p. 833; 1935.200.204, p. 834; 1935.200.229, p. 833; 1935.200.230, p. 871; 1956.24, p. 741. **Drums**, 1935.200.45, 47, p. 700.

Blocks

| No. | Page |
|--------------------|------|
| 1935.200.181 | 717 |
| 1935.200.183 | 704 |
| 1935.200.187 (two) | 717 |
| 1935.200.191 | 554 |
| 1955.51 | 757 |
| 1957.75 | 757 |
| 1957.78 | 647 |
| 1972.19 | 695 |
| 232 | 835 |
| 2933 | 708 |
| 4506 | 717 |

HARROW School Mus.

Statue, 956, p. 866.

HAVANA, Museo Nacional

Block, Inv.2, p. 758.

HEIDELBERG, Ägyptologisches Institut der Universität

Blocks, 27, p. 887; 34, p. 758; 559, p. 701. **Offering-table**, 908, p. 769.

HILDESHEIM, Roemer-Pelizaeus-Museum

Statues, 423, p. 865; 4886, p. 821. **Stelae**, 1876, p. 842; 2372, p. 816.

HONOLULU, Academy of Arts

Block, p. 695.

ISTANBUL, Archaeological Mus.

Stela, 10864, p. 741.

JERUSALEM, The Samuel Bronfman Biblical and Archaeological Mus.

Block, 71.89.339, p. 695.

KANSAS CITY, William Rockhill Nelson Gallery of Art

Statue, 51-1, p. 647. **Blocks**, 34-14, p. 695; 46-33, p. 501; 52-7.1, 2, p. 646.

KARLSRUHE, Badisches Landesmuseum

Block, H.1046, p. 706.

KRISTIANSTAD Mus.

Lintel, see Addenda.

LAUSANNE, Musée cantonal d'archéologie et d'histoire

Stela, 4727, p. 741.

LEICESTER, Museums and Art Gallery

Block, 67.1918, p. 758.

LEIPZIG, Ägyptisches Mus.

False-door, Inv.2897, p. 500. **Stela**, Inv. 1830, p. 842. **Lintel**, Inv.359 (lost), p. 686. **Cylinder-seal**, Inv.2657, p. 436. **Jar**, Inv. 3277, p. 436.

LENINGRAD, State Hermitage Mus.

Statue, 2961, p. 867. **Stelae**, 1072, p. 704; 1095-6, p. 816. **Blocks**, 1061, p. 660; 18143, p. 423; 18230, p. 896. **Offering-basin**, 2261, p. 769; **table**, 18106, p. 769. **Ushabti-coffin**, 999, p. 703.

LEYDEN, Rijksmuseum van Oudheden

Statues

| <i>No.</i> | <i>Page</i> |
|--------------|-------------|
| Inv.AST.1-3 | 663 |
| 7, 8 | 714 |
| 9 | 727 |
| 12 | 728 |
| 16 | 707 |
| 23 | 728 |
| 30a, b | 705 |
| 31 | 728 |
| 52 | 705 |
| Inv.L.VII.14 | 706 |

Niches with statues, Inv.AM.14a, 15-17, p. 708.

False-doors and stelae

| <i>No.</i> | <i>Page</i> |
|------------|-------------|
| Inv.AM.10 | 741 |
| AP.11 | 712 |
| F.1934/2.1 | 872 |
| 1939/2.6 | 563 |
| 1955/7.1 | 741 |
| 1970/5.1 | 741 |
| 1970/5.2 | 741 |

Blocks, etc.

| <i>No.</i> | <i>Page</i> |
|------------------|-------------|
| Inv.AM.102 | 758 |
| AP.40 | 758 |
| AP.54 | 714 |
| H.III.CCCC | 658 |
| H.III.PPPP, QQQQ | 659 |
| L.XI.7 | 708 |
| CI [V.29] | 660 |
| F.1939/2.5 | 758 |
| 1939/2.7 | 758 |
| 1939/2.8 | 484 |
| 1939/2.10, 11 | 484 |
| 1939/2.13, 14 | 758 |
| 1939/2.15 | 564 |
| 1939/2.16 | 758 |
| 1939/2.42-3 | 564 |

Chapels, Inv.AMT.1-35 and AP.52, p. 709; F.1904/3.1, p. 593; **walls**, Inv.AP.6, p. 705.

Pillars, Inv.AP.51, p. 714.

Sarcophagi, Inv.AMT.3, p. 718; AMT.106, p. 764. **Offering-tables**, Inv.AM.14b, p. 708; F.1939/2.4, p. 769; 1939/2.9, p. 769; 1939/2.12, p. 769. **Canopic-chest**, Inv.AM.2, p. 703. **Canopic-jars**, Inv.AAL.4c, d, p. 704. **Chair-leg**, Inv.AH.126, p. 703. **Cubit-measures**, Inv.AD.54, p. 774; I.635, p. 713. **Palette**, Inv.AAL.157, p. 709. **Pyramidion**, Inv.AM.6, p. 702. **Pommel of stick**, I.89, p. 712.

Rubber, I.219, p. 713. **Staffs and sticks**, Inv.AH.140C, p. 711; I.86, p. 775. **Clay statuettes with execration-texts**, F.1941/8.1-12, p. 549. **Vessels**, H.299, 305, 309, 360, p. 713.

LIÈGE, Musée Curtius

Canopic-jar, I/635 [Eg.61], p. 704.

LINKÖPING, Stifts- och Landsbibliotek

Blocks, p. 759.

LIVERPOOL, Merseyside County Museums

Stela, M.13850, p. 741. **Blocks**, 10.9.09.1, 2, p. 830; 55.67, p. 461. **Canopic-jars**, M.11242, p. 772; 11247, p. 772. **Pyramidion**, M.11015, p. 706.

LIVERPOOL, School of Archaeology and Oriental Studies

Block, E.91, p. 759.

LONDON, British Mus.

Statues

| <i>No.</i> | <i>Page</i> |
|------------|-------------|
| 9 | 837 |
| 171 | 728 |
| 615 | 863 |
| 659 | 869 |
| 1181 | 693 |
| 13346 | 729 |
| 24714 | 728 |
| 37883 | 848 |
| 67138 | 822 |
| 67143 | 822 |
| 67154 | 821 |
| 67155 | 822 |
| 67156 | 821 |

False-doors and stelae

| <i>No.</i> | <i>Page</i> |
|------------|-------------|
| 128 | 742 |
| 147 | 744 |
| 155 | 742 |
| 165 | 742 |
| 184 | 744 |
| 188 | 744 |
| 211-12 | 742 |
| 375 | 743 |
| 379 | 743 |
| 380 | 743 |
| 383 | 743 |
| 387 | 744 |
| 389 | 743 |
| 391 | 718 |
| 550-2 | 660 |
| 658 | 586 |
| 682 | 464 |
| 886 | 743 |
| 972 | 711 |
| 1143 | 578 |
| 1165 | 742 |
| 1171 | 692 |
| 1173-4 | 693 |

LONDON, False-doors and stelae (cont.):

| No. | Page |
|--------|------|
| 1191 | 742 |
| 1223 | 894 |
| 1278 | 456 |
| 1287 | 742 |
| 1288 | 693 |
| 1314 | 742 |
| 1324 | 893 |
| 1383 | 742 |
| 1429 | 586 |
| 1471-2 | 834 |
| 1848 | 448 |
| 26804 | 743 |
| ? | 834 |

Blocks

| No. | Page |
|---------|------|
| 326 | 759 |
| 498 | 873 |
| 682 | 464 |
| 872 | 579 |
| 1166 | 579 |
| 1168-70 | 692 |
| 1185 | 506 |
| 1192 | 490 |
| 1212 | 759 |
| 1234 | 759 |
| 1275 | 577 |
| 1344 | 829 |
| 1465 | 759 |
| 1469 | 855 |
| 1470 | 853 |
| 65952 | 479 |
| 67153 | 447 |

Tomb chapel, 718, p. 699.

Sarcophagus, 18, p. 709. **Coffin**, 6695, p. 765.

Offering-tables or basins, 1179, p. 769; 1345, p. 893; 29207-8, p. 769; 67243, p. 824; 68231, p. 447.

Canopic-jars, 36530, p. 703; 36531, p. 665; 36535, p. 703; 36625-8, p. 772. **Column**, 1385, p. 420. **Cylinder-seal**, 16774, p. 775. **Foundation deposit**, 48664, p. 832; 49234-5, p. 832. **Jar**, 29204, p. 394; **jar-lid**, 22961, p. 394. **Model knife**, 5472, p. 713. **Model mace-head**, 54989, p. 713. **Offering-stands**, 27339-40, p. 694. **Palettes**, 12778, p. 773; 36825, p. 773. **Pestle and mortar**, 5683, p. 713. **Shrine-fragments**, 68169, p. 824; 68173, p. 824. **Vessels**, 4492, p. 430; 4493, p. 425; 4640, p. 713; 22559, p. 422; 22817, pp. 430-1; 38074, p. 423; 68229, p. 446. **Wrapping of ibis mummy**, 67149, p. 825.

LONDON, University College Mus.

Statue, 30565, p. 823.

Stelae

| No. | Page |
|-------|------|
| 14357 | 744 |
| 14362 | 744 |
| 14391 | 870 |

| No. | Page |
|---------|------|
| 14392 | 833 |
| 14393-8 | 834 |
| 14400 | 849 |
| 14427 | 871 |
| 14463 | 712 |
| 14467 | 870 |
| 14470 | 870 |
| 14510 | 872 |
| 14572 | 871 |
| 14578 | 871 |
| 14610 | 816 |
| 15807 | 816 |
| 15993 | 817 |

Blocks

| No. | Page |
|----------|------|
| 73 | 850 |
| 408 | 759 |
| 2371-2 | 424 |
| 14285-7 | 503 |
| 14309-10 | 484 |
| 14477 | 759 |
| 14538 | 851 |
| 14539 | 396 |
| 14540 | 424 |
| 15507 | 851 |
| 15508 | 874 |
| 15858-9 | 830 |

Offering-tables, 8578, p. 570; 19658, p. 769.

Bowl, 15991, p. 831. **Furniture-fragment**, 30629, p. 824. **Ink-slab**, 11771, p. 899. **Sealing**, 17061, p. 875. **Shrine**, 14490, p. 874; **panels**, 8576-7, p. 824.

LONDON, Victoria and Albert Mus.

Stelae, 423-4.1908, p. 834.

LOS ANGELES, County Mus. of Art

Statue, 47.12, p. 429. **Blocks**, 47.8.3, p. 695; 47.8.5, p. 696.

LYONS, Musée des Beaux-Arts

Blocks, 91-2, p. 589.

MADISON (Wisc.), University of Wisconsin, Elvehjem Art Center

Block from false-door, 1973.141, p. 597.

MANCHESTER, University Mus.

Statue, 5187, p. 838.

Stelae, 4905-9, p. 834; 4910, p. 855; 4911, p. 833; 4914, p. 855; 5050, p. 849; 10780, p. 744.

Blocks, etc., 4933, p. 853; 5106, p. 854; 5375, p. 854.

Bowl, 5373, p. 899. **Canopic-jar**, 11098, p. 772. **Column-capitals**, 5102, p. 855; 5107, p. 855. **Column-drum**, unnumbered, p. 839. **Foundation-deposits**, 4938-46, p. 842; 4947-51, p. 832.

MARSEILLES, Musée d'Archéologie

- Statues**, 210, p. 867; 211, p. 729.
Stelae, 235, p. 745; 240-3, p. 745; 246, p. 817.
Block, 220, p. 759.
Sarcophagi, 263-4, p. 765; 266-7, p. 765.
Altar-pedestal fragment, 205, p. 839.
Canopic-jars, 300-2, p. 820.

MOSCOW, State Pushkin Mus. of Fine Arts

- Statue**, I.I.a.5577, p. 729. **Blocks**, I.I.a.6008, p. 759; I.I.b.317, p. 424; I.I.b.320, p. 693.

MUNICH, Staatliche Sammlung Ägyptischer Kunst

- Statues**, ÄS 1600, p. 729; ÄS 5570, p. 729; Gl.107, p. 729; Gl. WAF.33, p. 729.

False-doors, stelae, and side-pieces

| No. | Page |
|-----------|------|
| ÄS 11 | 718 |
| ÄS 48 | 745 |
| ÄS 51 | 745 |
| Gl.13 | 463 |
| Gl.41 | 745 |
| Gl.108 | 563 |
| Gl.110-12 | 563 |
| Gl.114 | 564 |
| Gl.116 | 563 |
| Gl.118 | 563 |
| Gl.119 | 564 |
| Gl.120 | 745 |

Blocks

| No. | Page |
|------------------------|------|
| ÄS 2971 | 760 |
| ÄS 4854-5 | 453 |
| ÄS 5875 | 589 |
| ÄS 5895-7 | 589 |
| ÄS 5970 | 696 |
| Gl.78 | 854 |
| Gl.93 | 872 |
| Gl.117 (now in Leyden) | 564 |
| Gl.121 | 564 |
| Gl.298 | 552 |

- Column-capital**, ÄS 79, p. 830. **Menat-fragment**, ÄS 5464, p. 875. **Shrine**, Gl.124, p. 874.

NAPLES, Mus. Nazionale

- Statue**, 1063, p. 867.

NEUCHÂTEL, Musée d'Ethnographie

Statues

| Eg. No. | Page |
|---------|------|
| 325-7 | 429 |
| 328-9 | 566 |
| 331 | 511 |
| 382 | 559 |
| 399 | 679 |
| 400 | 679 |
| 401-2 | 677 |
| 403 | 678 |
| 404-5 | 687 |
| 424-5 | 651 |

- False-doors and stelae**, Eg. 323, p. 568; 324, p. 407; 351-2, p. 687; 383, p. 573; 409, p. 675; 426, p. 568; 428, p. 571.

- Blocks**, Eg. 321-2, p. 570; 427, p. 678.

- Models, including boats**, Eg. 330, p. 567; 353-4, p. 543; 356-7, p. 653; 360-8, p. 653.

- Coffin-planks**, Eg. 336-7, p. 678.

NEW HAVEN (Conn.), Yale Univ. Art Gallery

- Canopic-jar**, 13.I.1953 (P.M. 6263), p. 772.

NEW YORK, Metropolitan Mus. of Art

Statues

| No. | Page |
|------------|------|
| 07.228.47 | 866 |
| 08.205.1 | 854 |
| 14.7.105-7 | 498 |
| 23.10.1 | 865 |
| 24.2.2 | 866 |
| 25.2.1 | 867 |
| 25.9 | 480 |
| 26.2.2-6 | 632 |
| 26.2.7 | 543 |
| 26.2.8, 9 | 567 |
| 26.9.2, 3 | 541 |
| 27.9.3-5 | 651 |
| 47.2 | 424 |
| 48.67 | 697 |
| 51.37 | 729 |
| 52.19 | 697 |
| 56.138 | 840 |
| 62.77 | 899 |
| 64.260 | 424 |
| 66.123.1 | 730 |
| 69.105 | 823 |
| 1971.51 | 826 |

False-doors, stelae, and side-pieces

| No. | Page |
|----------------------------------|------|
| 08.205.2A | 833 |
| 08.205.2B (later in Legg Colln.) | 834 |
| 08.205.2C | 833 |
| 08.205.2D, E | 834 |
| 10.175.71 | 563 |
| 10.175.72 | 564 |
| 11.150.50A | 591 |
| 58.123 | 453 |
| 60.144 | 870 |
| 64.100 | 646 |
| 67.50 | 501 |
| X.179 | 501 |

Blocks

| No. | Page |
|-----------|------|
| 04.2.4-6 | 760 |
| 08.205.12 | 835 |
| 09.183.1 | 830 |
| 11.150.50 | 589 |
| 21.2.25 | 760 |
| 58.44.2 | 453 |
| 58.161 | 501 |
| 66.99.151 | 760 |

NEW YORK (*cont.*):

Tomb-chapels, 08.201.1, p. 487; 13.183.3, p. 497. **Tomb walls**, 08.201.2, p. 498; 26.9.1, p. 541.

Sarcophagi, 07.229.1, p. 588; 11.154.1, p. 504; 11.154.6, p. 505; 11.154.7, p. 765 *and* *Addenda*; 14.7.1, p. 504.

Offering-table, 08.205.3, p. 835.

Column, 07.229.2, pp. 420-1. **Model statuette**, 26.2.10, p. 567. **Model sistrum**, 26.7.1450, p. 829. **Palette**, 37.2.1, p. 703.

Plaque, 17.194.2333, p. 875.

NORTHAMPTON, Central Mus. and Art Gallery

Statue, p. 730.

NORWICH, Castle Mus.

Coffin, 242.27, p. 765.

OBERLIN College, Ohio, Allen Memorial Art Mus.

Block, 43.302, p. 696.

OXFORD, Ashmolean Mus.

Statues, 1872.87, p. 730; 1913.163, p. 836.

False-door, 1836.479, p. 490. **Blocks**, 1909.1154, p. 830. **Offering-basin**, 1969.477, p. 447. **Offering-table**, 1971.135, p. 827.

PALERMO, Mus. Nazionale

Block, p. 873.

PARIS, Bibliothèque Nationale

Statue, p. 457.

PARIS, Musée Guimet

Blocks, 4849 (now in Louvre), p. 885; No.? (now in Louvre), p. 484. **Door-wing**, No.?, p. 693.

PARIS, Louvre

Statues

| <i>No.</i> | <i>Page</i> |
|---------------------------------|-------------|
| A 42 [N.43] | 730 |
| A 60 | 706 |
| A 71 [N.72] | 866 |
| A 72 | 731 |
| A 102 [N.116; E.3026] | 466 |
| A 103 [N.115; E.3025] | 466 |
| A 104 [N.110; E.3021] | 466 |
| A 105 [N.111; E.3022] | 466 |
| A 106 [N.117; E.3024] | 458 |
| A 107 [N.118] | 466 |
| A 108 [N.113] | 730 |
| A 109 [N.114] | 730 |
| A 116 [E.5343] | 730 |
| IM.223 [N.393] | 779 |
| N.390 [S.98] | 780 |
| N.391 | 778 |
| N.424 | 778 |
| N.432a [A.F.2962; S.1091] | 779 |
| N.432b, c [A.F.2963-4; S.971-2] | 780 |

| <i>No.</i> | <i>Page</i> |
|------------|-------------|
| N.435 | 818 |
| N.436 | 786 |
| N.437 | 779 |
| N.519 | 785 |
| N.2290 | 458 |
| N.2456 | 818 |
| N.3952 | 828 |
| E.7692-3 | 869 |
| E.7703 | 869 |
| E.7704 | 730 |
| E.7704 bis | 730 |
| E.10776 | 730 |
| E.17449 | 818 |
| E.25480 | 864 |
| A.F.2573 | 827 |

Apis-stelae, *see* Appendix I.**False-doors and stelae**

| <i>No.</i> | <i>Page</i> |
|----------------|-------------|
| B 49 [N.153] | 501 |
| C 101 [N.252] | 746 |
| C 119 [N.270] | 746 |
| C 208 | 746 |
| C 210 [N.306] | 746 |
| C 213 [E.3337] | 664 |
| C 222 [N.314] | 746 |
| C 226 [N.320] | 746 |
| C 318 [IM.131] | 780 |
| N.3389 | 746 |
| E.14184 | 567 |
| E.14185 | 678 |
| E.17233 | 568 |
| E.27157 | 745 |

Blocks

| <i>No.</i> | <i>Page</i> |
|-------------------------------|-------------------------------|
| B 1 [N.121] | 500 |
| B 2 [N.122] | 500 |
| B 6 | 701 |
| B 8 | 702 |
| B 33 | 779 |
| B 48 [IM.2614; N.151; E.3028] | 820 |
| B 50 [N.152] | 820 |
| B 56 [E.11273] | 660 |
| B 57 [E.11274] | 760 |
| C 154 [N.322] | 760 |
| C 155 [E.3908] | 893 |
| C 156 [N.311] | 760 |
| C 157 [N.307] | 503 |
| N.402 [S.993] | 778 |
| N.423 [S.119] | 779 |
| N.518 | 819 |
| E.3065 | 760 <i>and</i> <i>Addenda</i> |
| E.11161 | 699 <i>and</i> <i>Addenda</i> |
| E.14223 | 501 |
| E.15562 (now in Musée Rodin) | 655 |
| E.17381 | 420 |
| E.17499 | 760 |
| E.22348 | 885 |
| E.25408 | 698 <i>and</i> <i>Addenda</i> |
| E.25497 | 819 |

Objects in Museums

1011

| No. | Page | No. | Page |
|---|------|----------------------------------|------|
| E.25507-49 | 646 | 29.75.502 | 858 |
| E.25680 | 760 | 29.75.511 | 859 |
| E.25681 | 646 | 29.75.525 | 858 |
| A.F.6760 | 484 | 29.75.531 | 859 |
| | | 29.75.533 | 859 |
| Tomb-chapel , E.10958, p. 634. | | 29.75.544 | 859 |
| Doorway , N.420, p. 796. | | 29.75.551 | 858 |
| Niche , E.11286, p. 893. | | 29.84.482 | 859 |
| Sarcophagi , D 2 [N.338], p. 707; D 8 [N.344], p. 765; D 9 [N.345], p. 766; D 13 [N.349], p. 765. | | Stelae | |
| Offering-tables , D 49 [E.3070], p. 708; D 65 [E.3867], p. 588; D 79, p. 819. | | No. | Page |
| Altar-pedestal fragment , D 61, p. 840. | | E 12506-8 | 834 |
| Amulet , N.5416, p. 785. Magical bricks , IM.3597-8 [N.842], p. 782; IM.5336-9 [N.842], p. 780. Canopic-boxes , N.2679-80 [E.2774-5], p. 719. Canopic-jars , N.2975-8, p. 772; N.5438, p. 819; S.1151-4, p. 781; S.1160-3, p. 782; S.1164-7, p. 781; No.?, p. 588; unnumbered, p. 782. Colonnette , N.760 [E.69], p. 783. Columns , E.10959, p. 420; two unnumbered, p. 760. Cubit-measure , N.1538, p. 663. Hawk-coffin , A.F.448, p. 819. Model vase , E.8420, p. 712. Palettes , N.3026, p. 773; A.F.483, p. 703. Pectorals , IM.2886 [N.767; E.79], p. 782; IM.2894 [N.762; E.68], p. 783. Pendants , No. 456, p. 781. Pyramidia , D 14 [N.355], p. 707; D 20 [N.361], p. 770; D 21 [N.362], p. 655; D 44 [N.363], p. 708. Vessels and lids , N.442, p. 785; N.455, p. 781; N.462, p. 820; N.482, p. 781; N.484, p. 781; N.495, p. 504; N.2255, p. 820; N.5415, p. 785; N.5418, p. 785; A.F.6735, p. 713. | | E 12509 | 833 |
| | | E 13578 | 859 |
| | | E 13579-83 | 860 |
| | | E 13585-6 | 860 |
| | | E 13588-91 | 860 |
| | | E 13592 | 859 |
| | | E 13593-4 | 860 |
| | | E 13595 | 859 |
| | | E 13596 | 860 |
| | | E 13597-8 | 859 |
| | | E 13599-601 | 860 |
| | | E 13602 | 859 |
| | | E 13603-7 | 860 |
| | | E 13608-10 | 859 |
| | | E 13611 | 860 |
| | | E 13612-14 | 859 |
| | | E 13615-17 | 860 |
| | | E 13618 | 859 |
| | | E 13619-22 | 860 |
| | | E 13623-5 | 859 |
| | | E 13626 | 860 |
| | | E 13627-8 | 859 |
| | | E 13629-32 | 860 |
| | | E 13641 | 860 |
| | | E 13651 | 860 |
| | | E 14318 | 746 |
| | | 29.75.554 | 860 |
| | | 29.75.557-8 | 860 |
| | | 29.75.560 | 860 |
| | | 29.75.561 | 859 |
| | | 29.75.563-7 | 860 |
| | | 29.75.574 | 860 |
| | | 29.84.76 | 860 |
| | | 29.84.742 | 860 |
| | | 29.85.732 | 860 |
| PARIS , Musée Rodin | | | |
| Statues , 90, p. 731; 284, p. 838. Blocks , 104, p. 655; 235, p. 655; 237, p. 702. | | | |
| PARMA , Mus. Nazionale di Antichità | | | |
| Block , E.108, p. 702. | | | |
| PHILADELPHIA , Pennsylvania University Mus. | | | |
| Statues | | Blocks, etc. | |
| No. | Page | No. | Page |
| E 12038 | 858 | E 12279 | 850 |
| E 12326 | 836 | E 13557 | 856 |
| E 13644-5 | 858 | E 13566-7 | 860 |
| E 13646 | 859 | E 13568-9 | 855 |
| E 13647 | 858 | E 13570 | 860 |
| E 13648 | 859 | E 13572-3 | 860 |
| E 13652-3 | 858 | E 13634 | 860 |
| E 13655 | 859 | E 13643 | 860 |
| E 13658 | 859 | E 13684 | 860 |
| E 13661 | 859 | E 14345 | 853 |
| E 14301 | 731 | E 17527 | 856 |
| 29.75.454 | 859 | 29.75.555 | 860 |
| 29.75.484 | 858 | | |
| 29.75.499 | 859 | Chapel , E 15729, p. 455. | |

PHILADELPHIA (*cont.*):

Doorways, E 13552-4, p. 857; E 13560, p. 856; E 13575, p. 855.

Columns, E 636, p. 856; E 13558-9, p. 856; E 13576-7, p. 855. **Windows**, E 13564-5, p. 856. **Niche**, E 13662, p. 860.

PITTSBURGH, Mus. of Art, Carnegie Institute

False-door, 73.11, p. 501. **Block**, 3755, p. 853. **Boat**, 1842, p. 885.

PORT SA'ID Mus.

False-door, p. 562.

PRINCETON (N.J.), University Art Mus.

Stela, 42-48, p. 746.

PROVIDENCE, Rhode Island School of Design

Statue, 25.031, p. 731.

READING, Ure Mus. of Greek Archaeology

Sistrum, E.63.18, p. 875.

RICHMOND (Va.), Mus. of Fine Arts

Blocks, 51.19.10, p. 760; 55.6.2, p. 647; 58.9, p. 760.

RIGGISBERG, Abegg-Stiftung

Block, 12.39.67, p. 646.

ROCHDALE Mus.

Stela, p. 834. **Blocks**, pp. 831, 835.

ROCHESTER (N.Y.), University Memorial Art Gallery

Blocks, 42.55, p. 661; No. ?, p. 506.

ROME, Mus. Barracco

Block, 2, p. 761.

ROME, Mus. di Villa Albani

Blocks, 554, p. 715; 557, p. 715.

ROVIGO, Mus. dell'Accademia dei Concordi

Block, 3, p. 761.

SAN JOSÉ, Rosicrucian Mus.

Vessel, p. 713.

SEATTLE (Wash.), Art Mus.

Block, 11.6 (now in Baltimore, Md., Walters Art Gallery), p. 718.

STOCKHOLM, Medelhavsmuseet

Statues, MM.10224, p. 731; MM.11410, p. 731; MM.11411-13, p. 567; MME.1974:143, p. 731.

False-doors, stelae, and side-pieces, MM.11407-8, p. 544; MM.11432, p. 569; MM.11434, p. 568; MM.11443, p. 572.

Blocks, MM.32011, p. 709; MM.32013-15, p. 709; NME 26, p. 761; NME 38 [MM.32012], p. 761; NME 63 [MM.32016], p. 761.

Coffin, MM.11399, p. 766. **Offering-basin**, NME 43, p. 588. **Canopic-jars**, MM.19233, p. 587.

STRASBOURG, Univ. Institut d'Égyptologie

Statues, 963-4, p. 731. **Blocks**, 342, p. 501; 2439A, p. 702.

SYDNEY University, Nicholson Mus. of Antiquities

Stela, R.1141, p. 747. **Block**, R.1143, p. 839. **Pillar-fragments**, No. ?, p. 554.

TEL AVIV, Mus. Haaretz

Clay statuettes with execration-texts, p. 549.

TOLEDO (Ohio), Mus. of Art

False-door fragment, 59.39, p. 453. **Block**, 59.40, p. 453.

TORONTO, Royal Ontario Mus. of Archaeology

Statues, 969.137.1, p. 822; 972.51.1, p. 826; 972.51.16, p. 822.

Blocks, 953.116.1, p. 646; 953.116.2, p. 647; 955.79.1, p. 662; 955.79.2, p. 654.

Sealings, 969.137.7, p. 507; 969.137.8, p. 442. **Shrine**, 969.137.2, p. 824.

TOULOUSE, Musée Labit

Canopic-jar, 49.289, p. 709.

TRENTO, Mus. di Buon Consiglio

Stela, p. 747.

TRIER, Rheinisches Landesmuseum

Coffin, G.536, p. 766.

TÜBINGEN, Ägyptologisches Institut der Universität

Blocks, Inv.1098, p. 761; Inv.1768, p. 761.

TURIN, Mus. Egizio

Statue, Cat. 3020, p. 839. **Stela**, Cat. 1578, p. 747. **Jams**, Sup. 1255-6, p. 481. **Block**, Sup. 1257, *see* Addenda. **Cubit-measure**, Cat. 6347, p. 773.

UPPSALA, Victoriamuseum för Egyptiska Forn-saker

Stelae, 23, p. 747; 35, p. 747. **Blocks**, 9, p. 761; 21, p. 424; B.63, p. 761. **Sarcophagus-lid**, 10, p. 766.

VATICAN, Mus. Gregoriano Egizio

False-door, Inv. 242, p. 747. **Canopic-jars**, Inv. 141-4, p. 772; Inv. 229-32, p. 720.

VIENNA, Kunsthistorisches Mus.

Statues, Inv. 5749-50, p. 838; 5753-4, p. 868; 5756-67, p. 778; 5768-9, p. 838; 5773, p. 818; 5774, p. 838; 5782, p. 864; 5802, p. 837.

False-doors and stelae

| <i>Inv. No.</i> | <i>Page</i> |
|--------------------------|-----------------|
| 125 | 719 |
| 130 | 748 |
| 153 | 748 |
| 162 | 748 |
| 1841 (<i>in error</i>) | 452 and Addenda |
| 5814 | 706 |
| 5817-20 | 452 |
| 5824 | 817 |
| 5827 | 817 |
| 5831 | 817 |
| 5833 | 817 |
| 5841 | 817 |
| 5852-3 | 817 |
| 5857 | 748 |
| 6126 | 817 |

Blocks, Inv. 214, p. 661; 5081-3, p. 819; 5095-7, p. 819; 5815, p. 706; 5816, p. 761.

Sarcophagi, Inv. 1, p. 507; 4, p. 766; **coffin-plank**, Inv. 240, p. 507.

Ibis mummy, Inv. 8639, p. 825. **Pyramidion**, Inv. 5908, p. 664.

VIENNE (Isère), Musée des Beaux-arts

Stelae, 1555, p. 715.

WASHINGTON (D.C.), National Mus.

Cartonnage-fragment, 1415, p. 767.

WORCESTER (Mass.), Art Mus.

Block, 1931.99, p. 696.

ZAGREB, Arheološki Muzej

Vessels, 548, p. 713; 567, p. 713.

ZÜRICH, Rietbergmuseum

Blocks, *see* Addenda.

CONTENTS OF FASCICLE 3
PYRAMID-FIELD OF ŞAQQÂRA
(continued)

III. SACRED ANIMAL COMPLEXES

- A. Eastern Group, 777
- B. Western Group with the Serapeum
Avenue of Sphinxes, 778. East Temple, 778. Approach to Serapeum Enclosure, 779. Pylon, 780. Isolated Tombs of Apis-bulls, 780. 'Lesser Vaults', 784. 'Greater Vaults', 796. Unassigned Apis-Stelae, 805. Objects connected with the Serapeum, 817.
- C. Northern Group, 820

IV. MISCELLANEOUS, 827

EL-'AZÎZÎYA, 830
MÎT RAHÎNA

Northern Enclosure, 830

Ptaḥ Enclosure with Dependencies

Temple of Ptaḥ, 831.

Subsidiary Buildings and Monuments, 840.

Including: C. Colossus of Ramesses II, 840. D. Stela of Apries, 840. E. Alabaster Sphinx, 841. G. Embalming House of Apis-bulls, 841. I. Temple of Tuthmosis IV, 842. J. Chapel of Sethos I, 843. K and L. Temples of Ramesses II, 843, 845. M. Tombs of High Priests of Memphis, 846.

Finds from Ptaḥ Enclosure and Dependencies, 847.

Kôm el-Nawa, 851

Kôm el-Arba'in, 851

Kôm el-Fakhry, 852

Kôm el-Rabî'a, 852

Kôm el-Qal'a, 854

Miscellaneous from Mît Rahîna

Statues, 863. Stelae, 870. Blocks, 872. Various, 874.

EL-BADRASHEIN, 875
PYRAMID-FIELD OF DAHSHÛR

I. PYRAMIDS

- A. Northern Pyramid-complex of Snefru, 876.
- B. Southern Pyramid-complex of Snefru, 877.
- C. Pyramid-complex of Sesostri III, 882.
- D. Pyramid-complex of Amenemḥet II, 885.
- E. Pyramid-enclosure probably of Dynasty XIII, 887.
- F. Pyramid-complex of Amenemḥet III, 887.
Tomb of King Awibrē I Ḥor, 888; of Nubḥetepti-khred, 889.
- G and H. Pyramids probably of Dynasty XIII, 890.
- I. Pyramid of Ameny-Ḳemau, 890.

II. NECROPOLIS

- A. East of the Northern Pyramid of Snefru, 890.
- B. East of the Southern Pyramid of Snefru, 894.
- C. North of the Enclosure of Sesostri III, 896.
- D. South of the Enclosure of Amenemḥet II, 898.

III. MISCELLANEOUS, 898

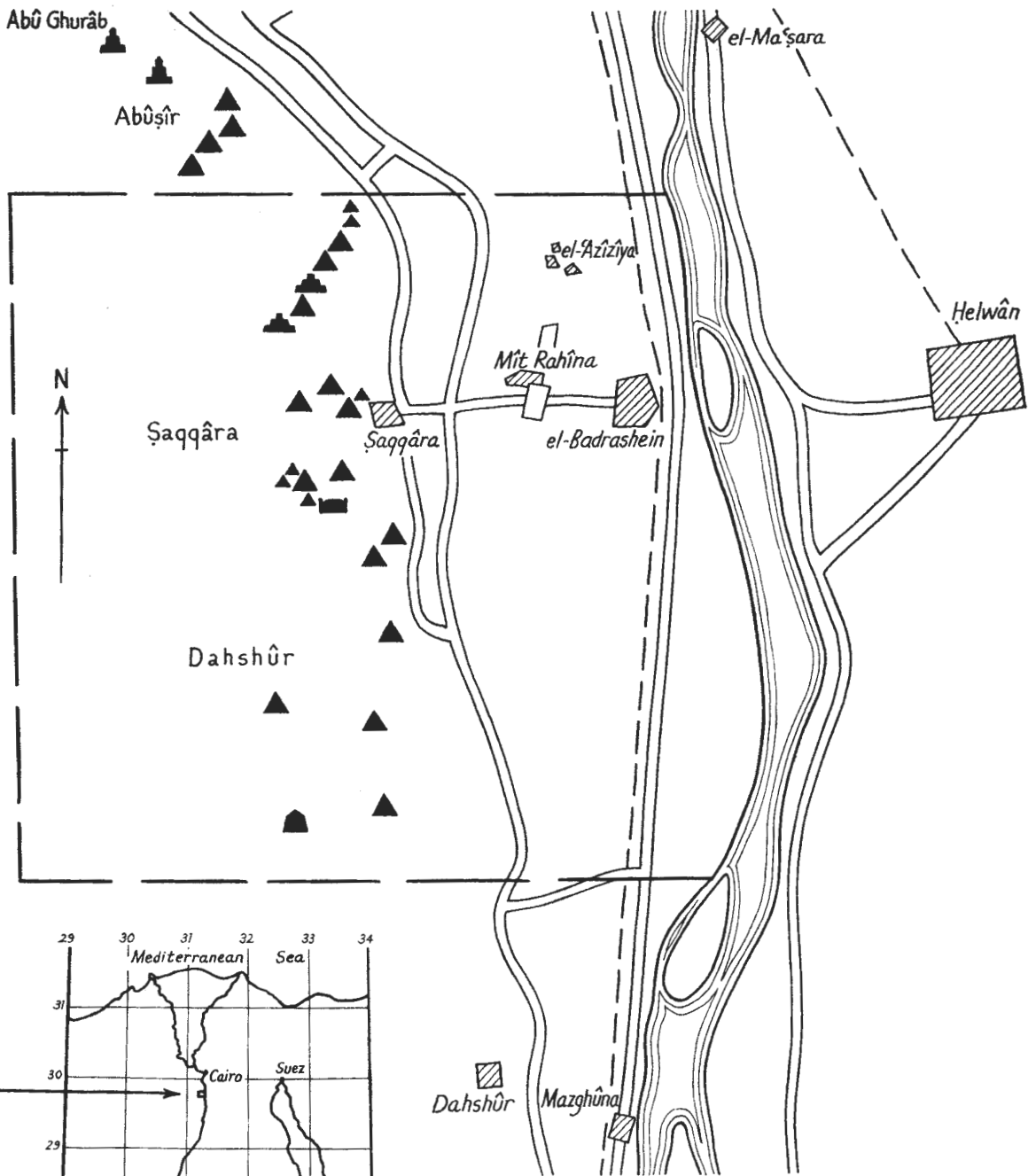

Key-map.

The south part of the Memphite Necropolis dealt with in *Top. Bibl.* iii² Pt. 2.

XLI. Şaqqâra. Pyramids.

See pp. 393-435.

- A. Teti
- B. Userkaf
- C. Neterikhet (Zoser)
- D. Sekhemkhet
- E. 'Great Enclosure'
- F. Unis
- G. Pepy I
- H. Isesi
- I. Merenrê I
- J. Kâkarê Ibi
- K. Pepy II
- L. Shepseskaf
- M. Userkarê Khenzer
- N. Pyramid-enclosure of Dyn. XIII

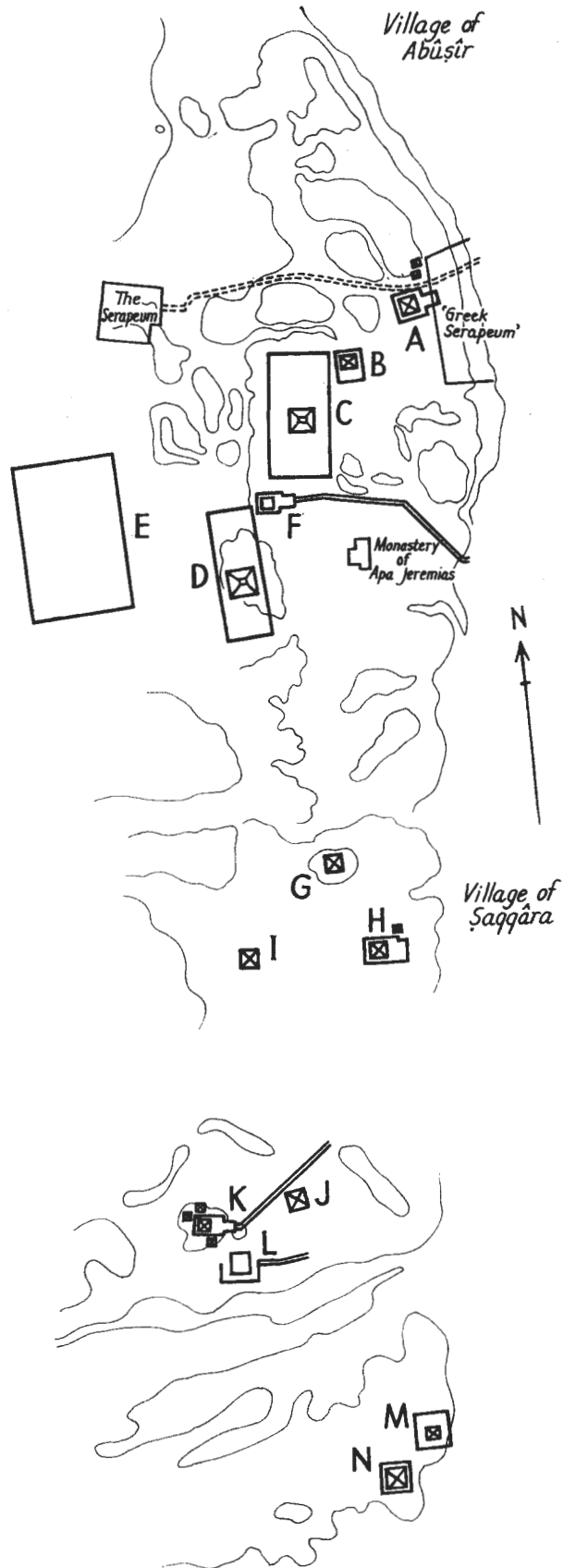

XLII. Şaqqâra. Necropolis.

See pp. 435 ff.

- A. North of the Step Pyramid
- B. Around Teti Pyramid
- C. East of the Step Pyramid
- D. In the Step Pyramid Enclosure
- E. West of the Step Pyramid
- F. Around the Pyramid-complex of Unis
- G. Between the Monastery of Apa Jeremias and the Enclosure of Sekhemkhet
- H. Around the Pyramids of Pepy I, Merenrê I and Isesi
- I. Around the Pyramids of Ibi and Pepy II, Maştabet Faraʿûn, and the Pyramid of Userkarê Khenzer

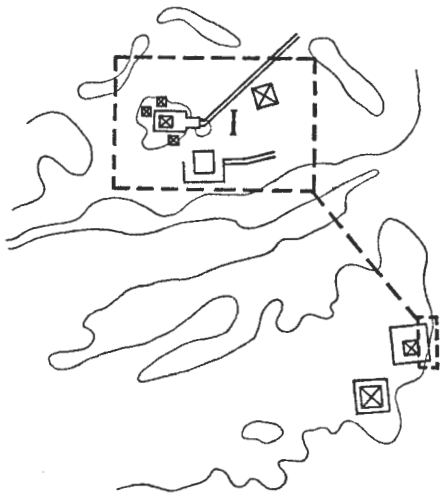
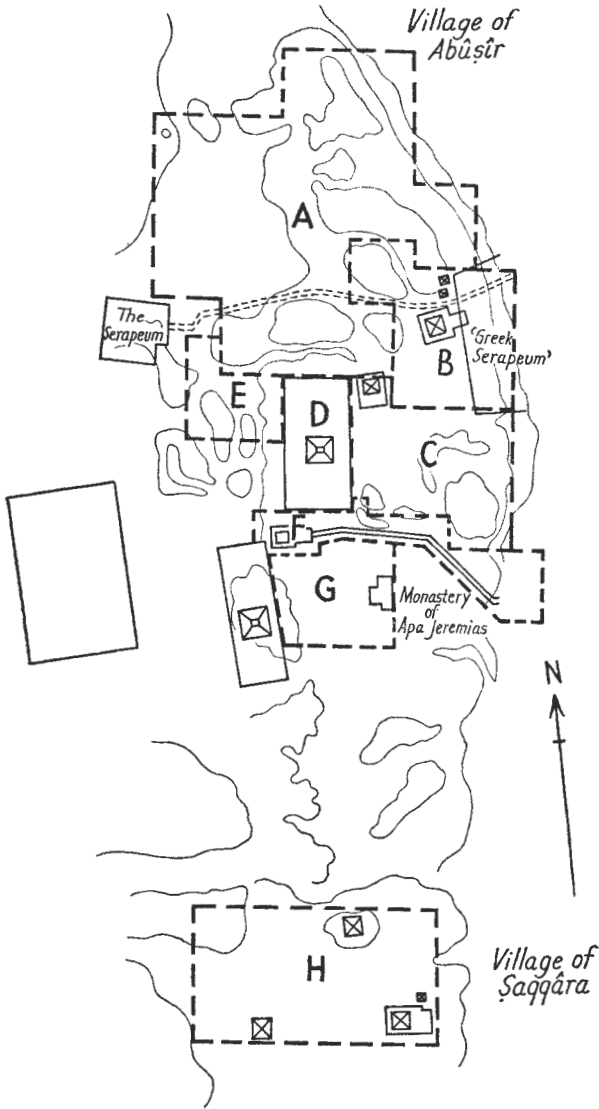

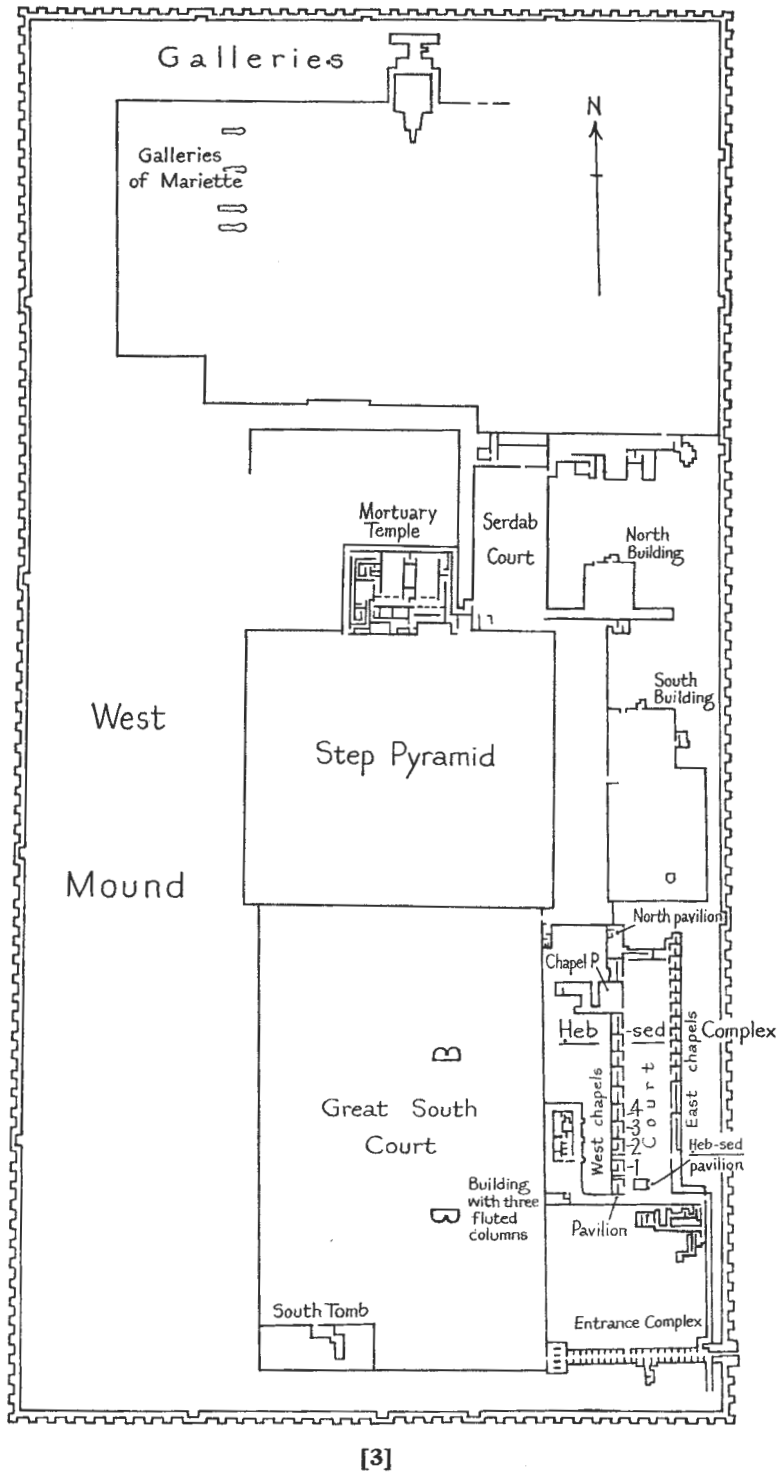
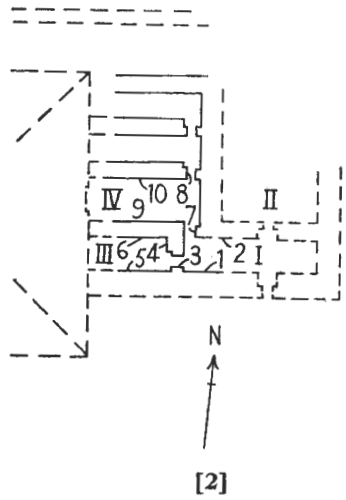
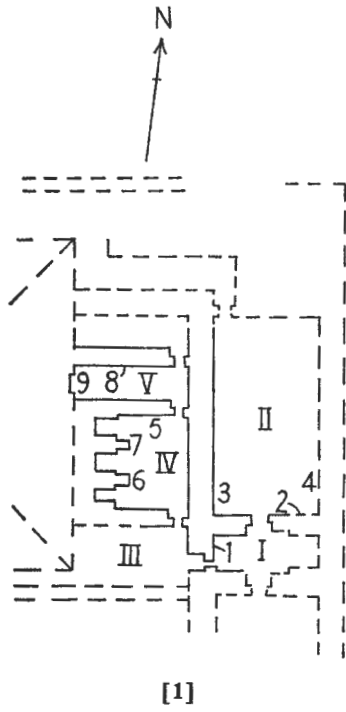

XLIII. Şaqqâra.

1 and 2. Pyramid-enclosures of Iput I and Khuit. *See pp. 396-7.*

3. Step Pyramid Enclosure of Neterikhet (Zoser). *See pp. 399-415.*

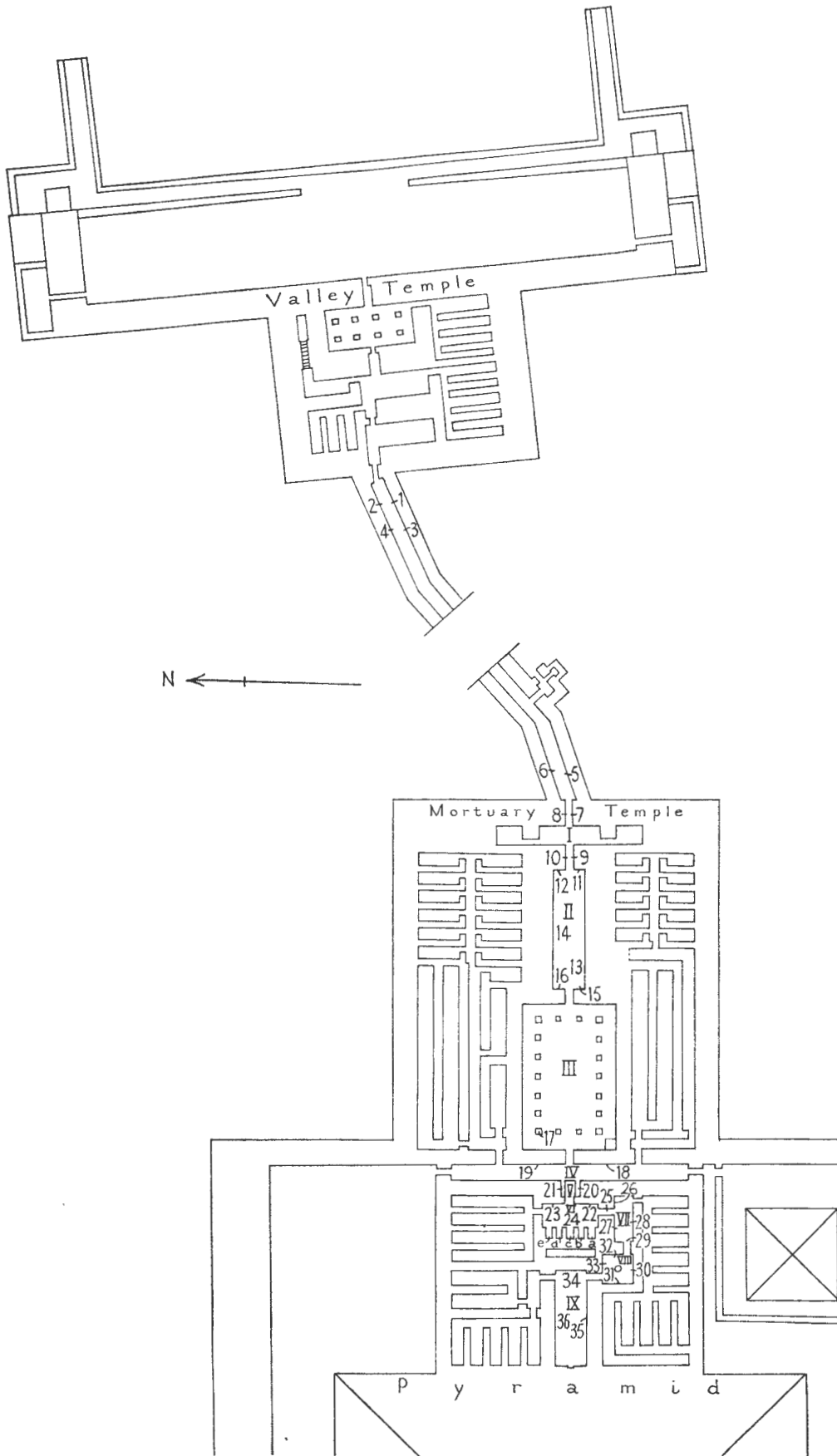

XLIV. Şaqqâra. Pyramid-complex of Pepy II. See pp. 425-31.

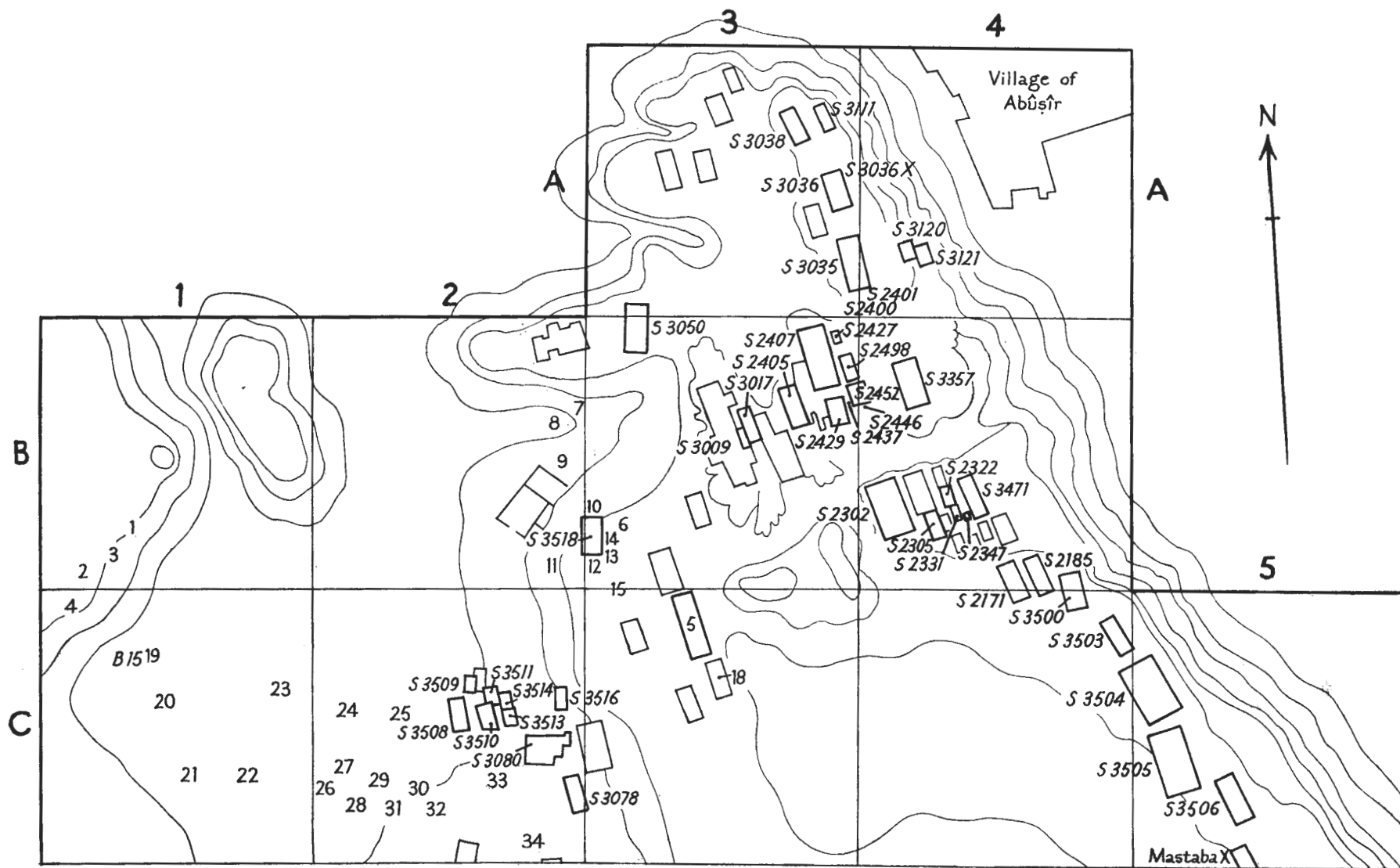

XLV. Şaqqâra. North of the Step Pyramid (north section). See pp. 435-507.

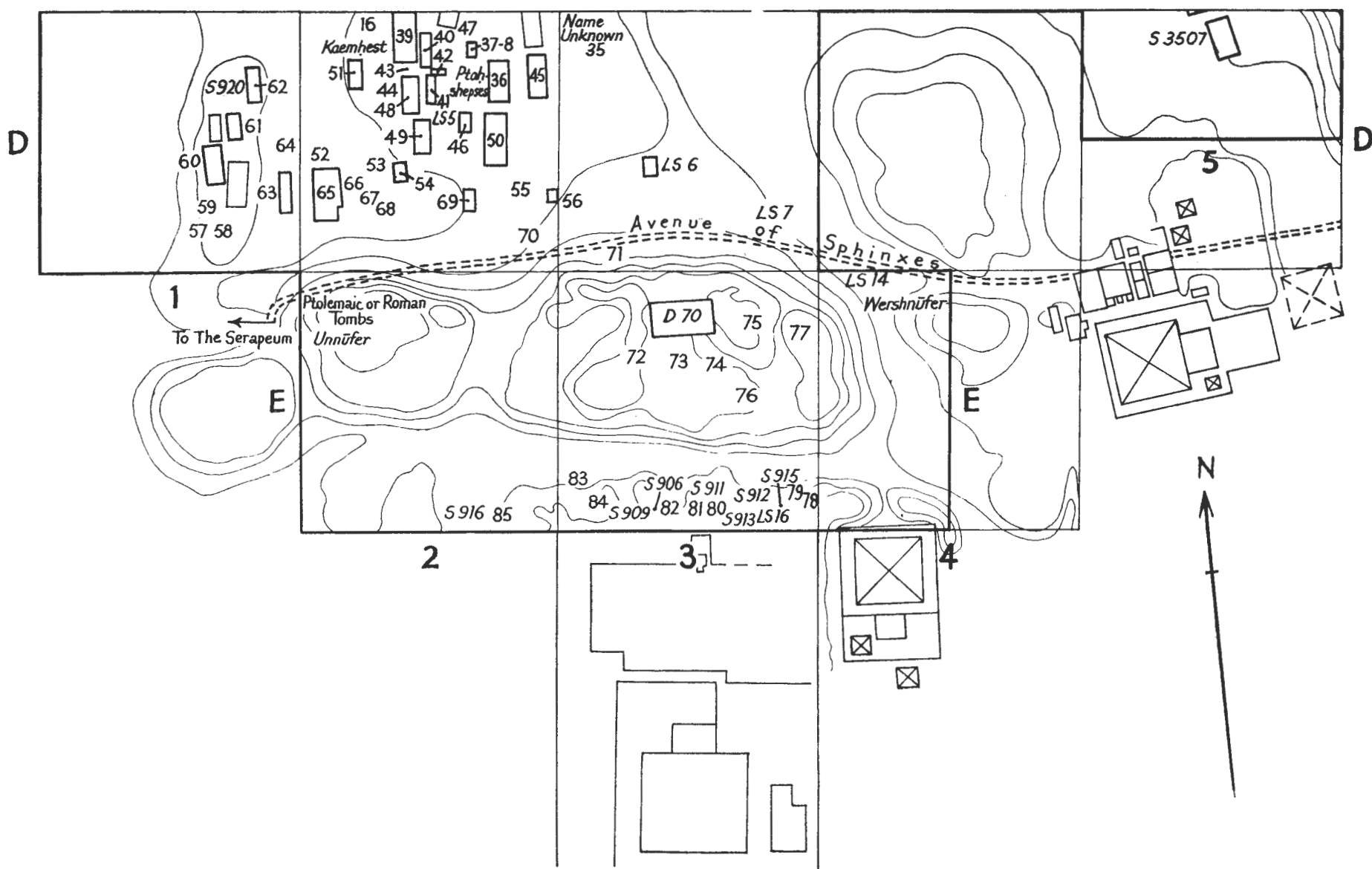

XLVI. Şaqqâra. North of the Step Pyramid (south section). See pp. 435-507.

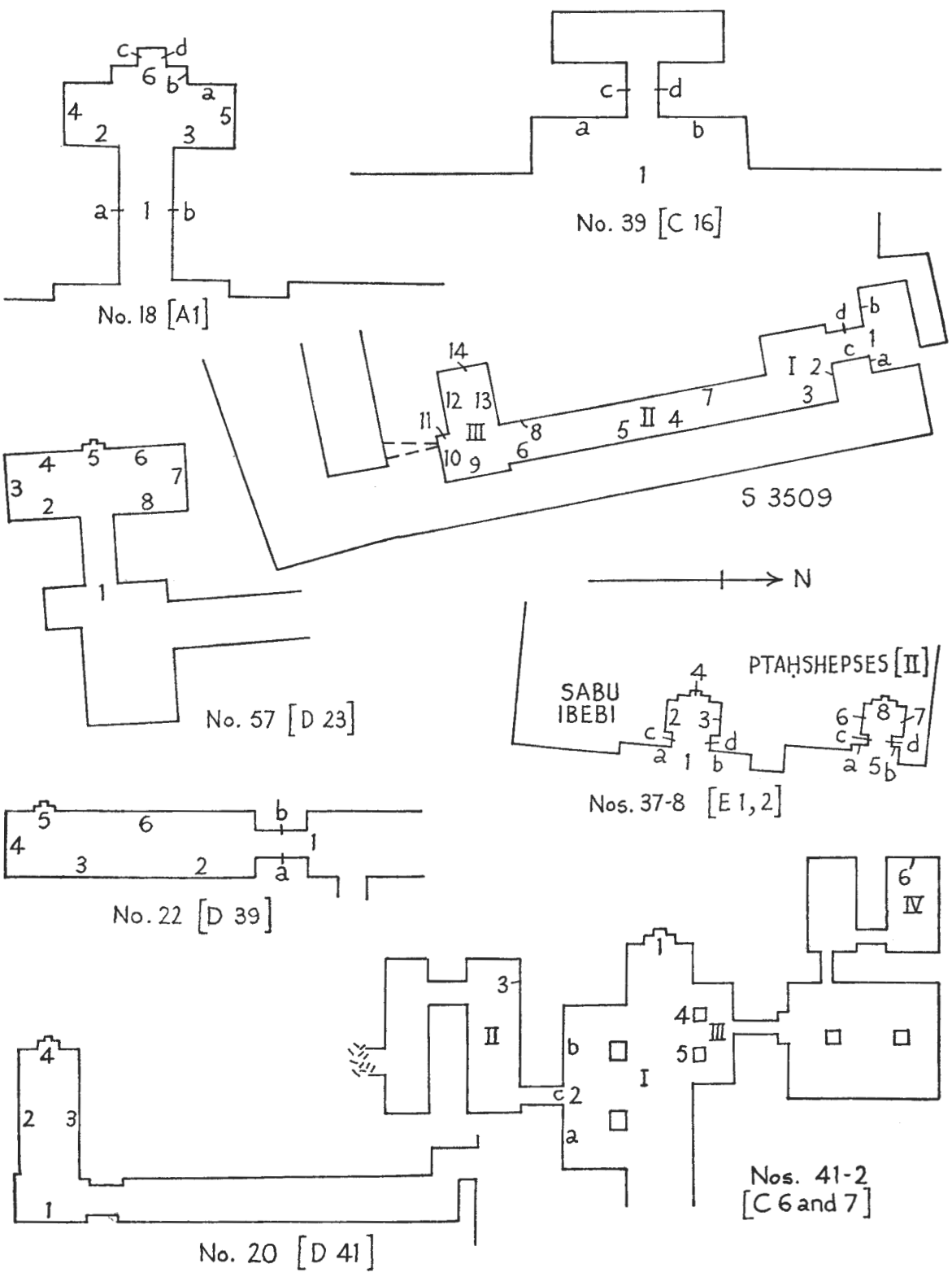

XLVII. Şaqqâra. Plans of tombs.

XLVIII. Şaqqâra.
 Plan of tomb No. 60 [D 22],
 Ty. See pp. 468-78.

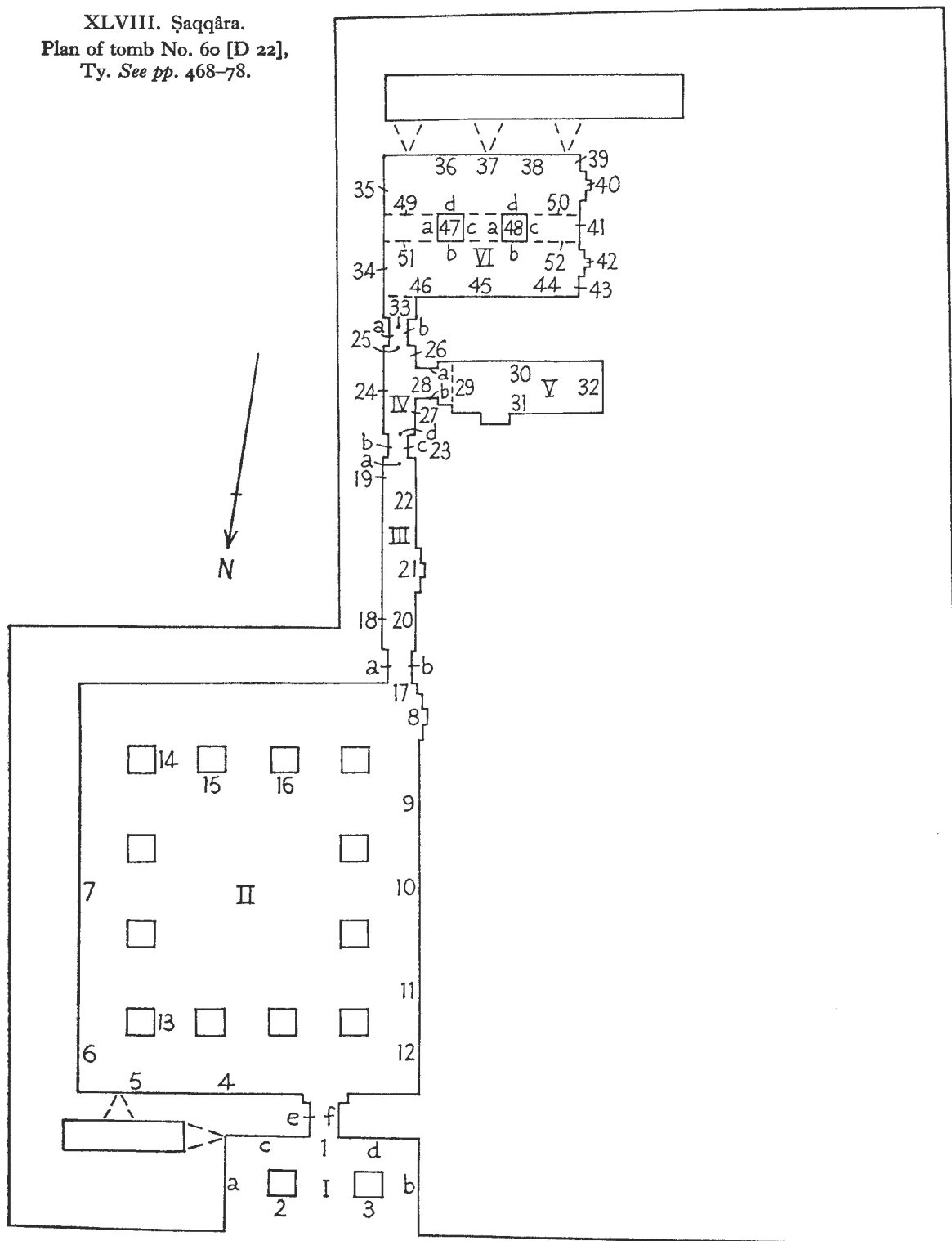

No. 60 [D 22]

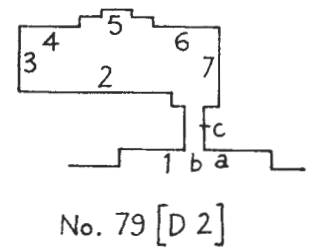
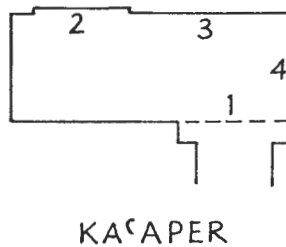
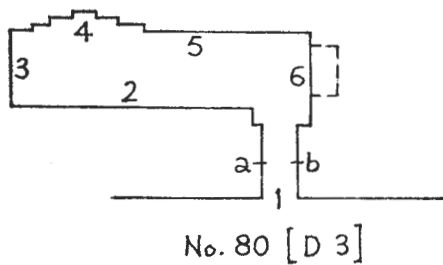
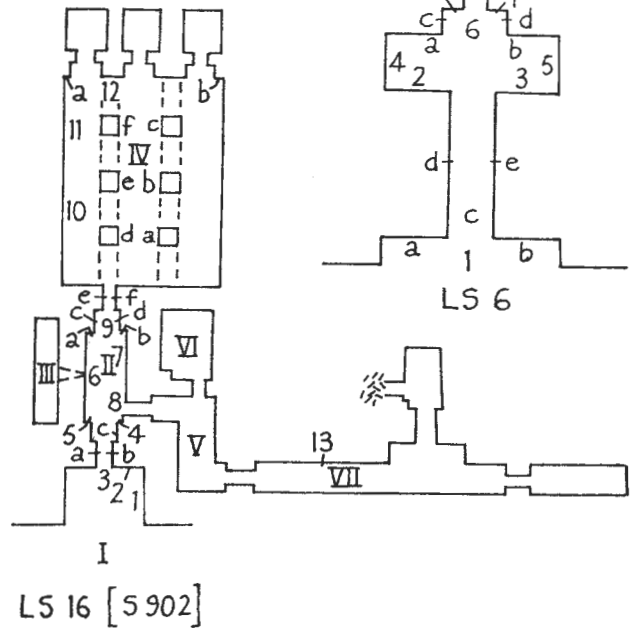
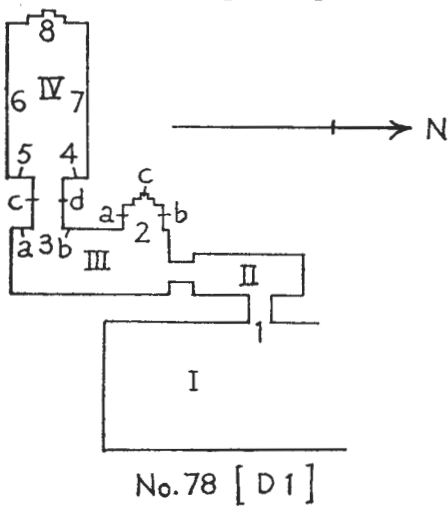
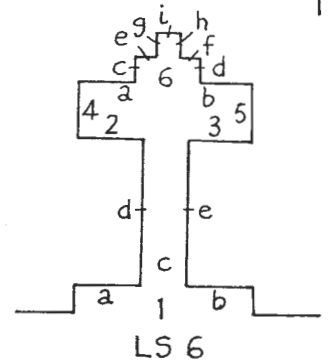
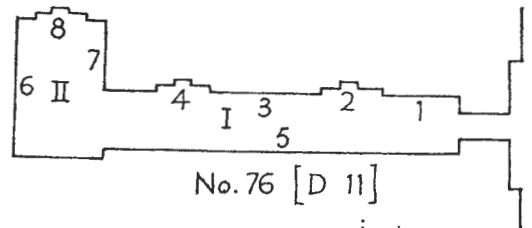
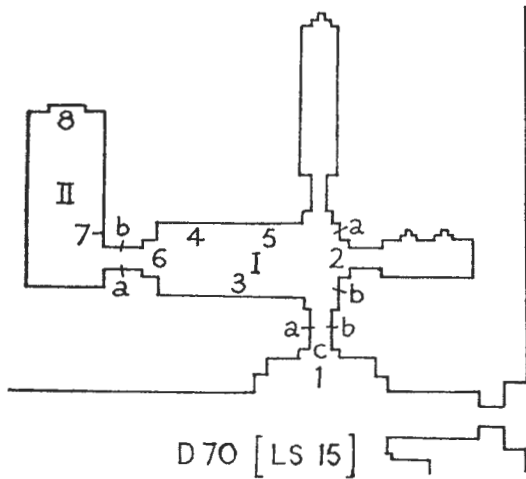
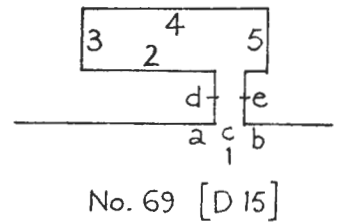
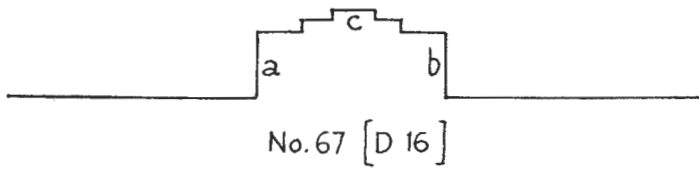

XLIX. Şaqqâra. Plans of tombs.

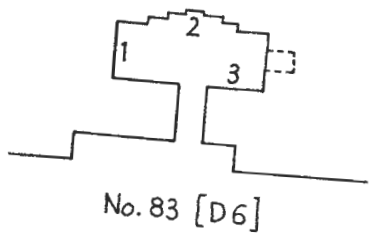

No. 83 [D6]

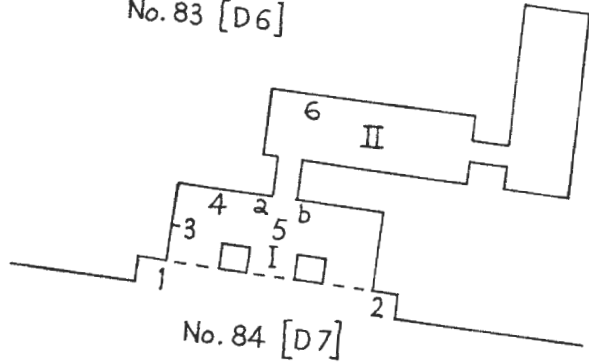

No. 84 [D7]

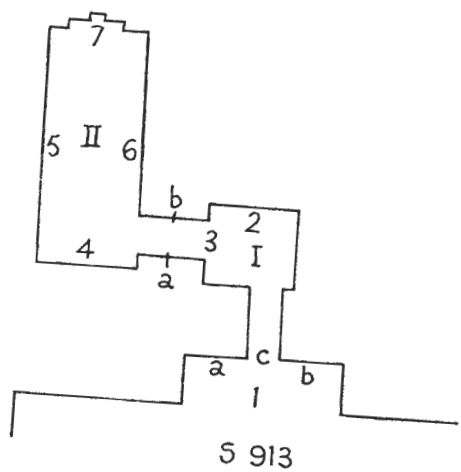

5 913

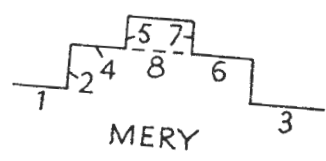

MERY

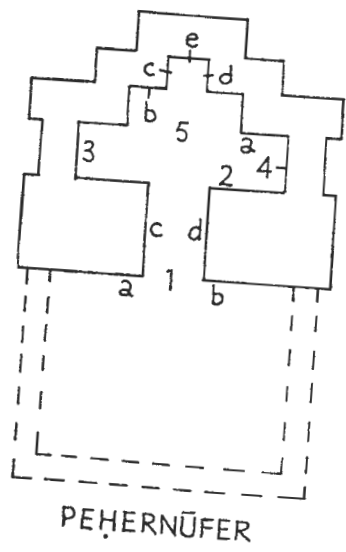
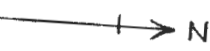

PEHERNÜFER

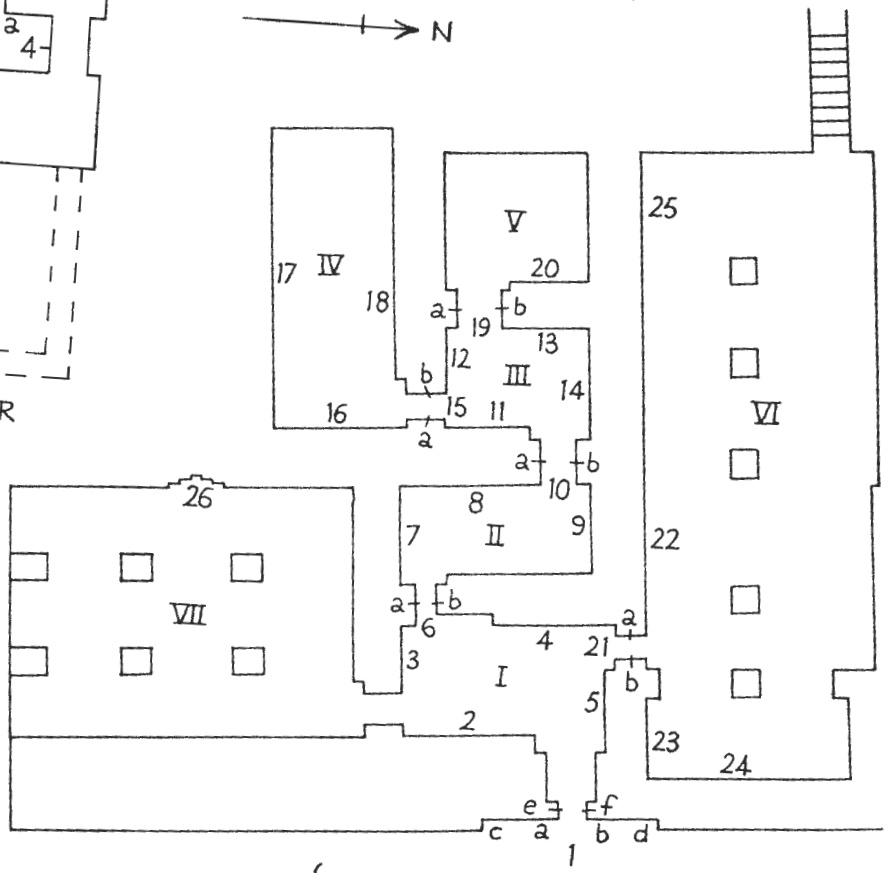

ANKHMAÇHOR SESI

L. Şaqqâra. Plans of tombs.



LI. Şaqqâra. Around Teti Pyramid. See pp. 508-73.

LII. Şaqqâra. North of Teti Pyramid. See pp. 508-57.

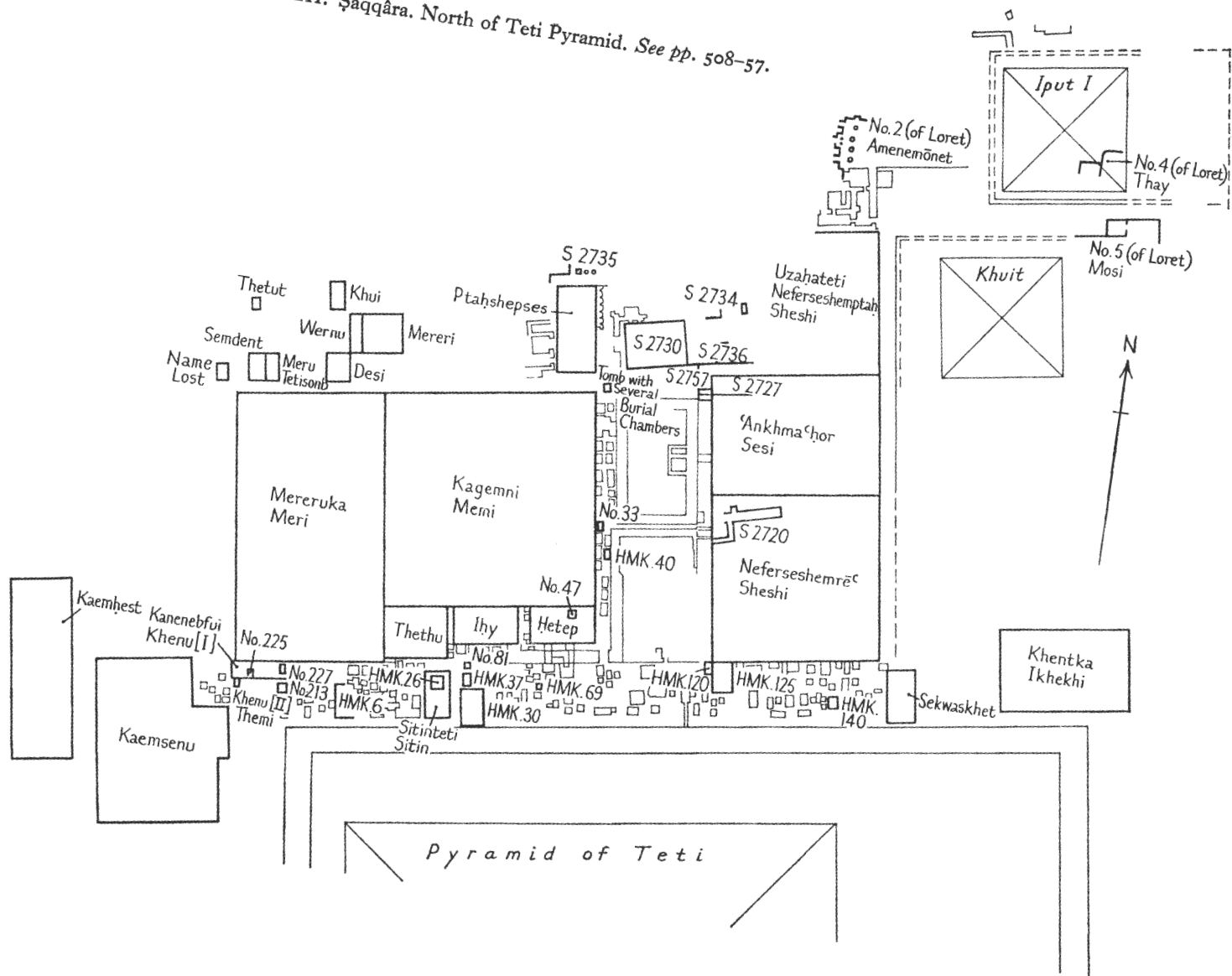

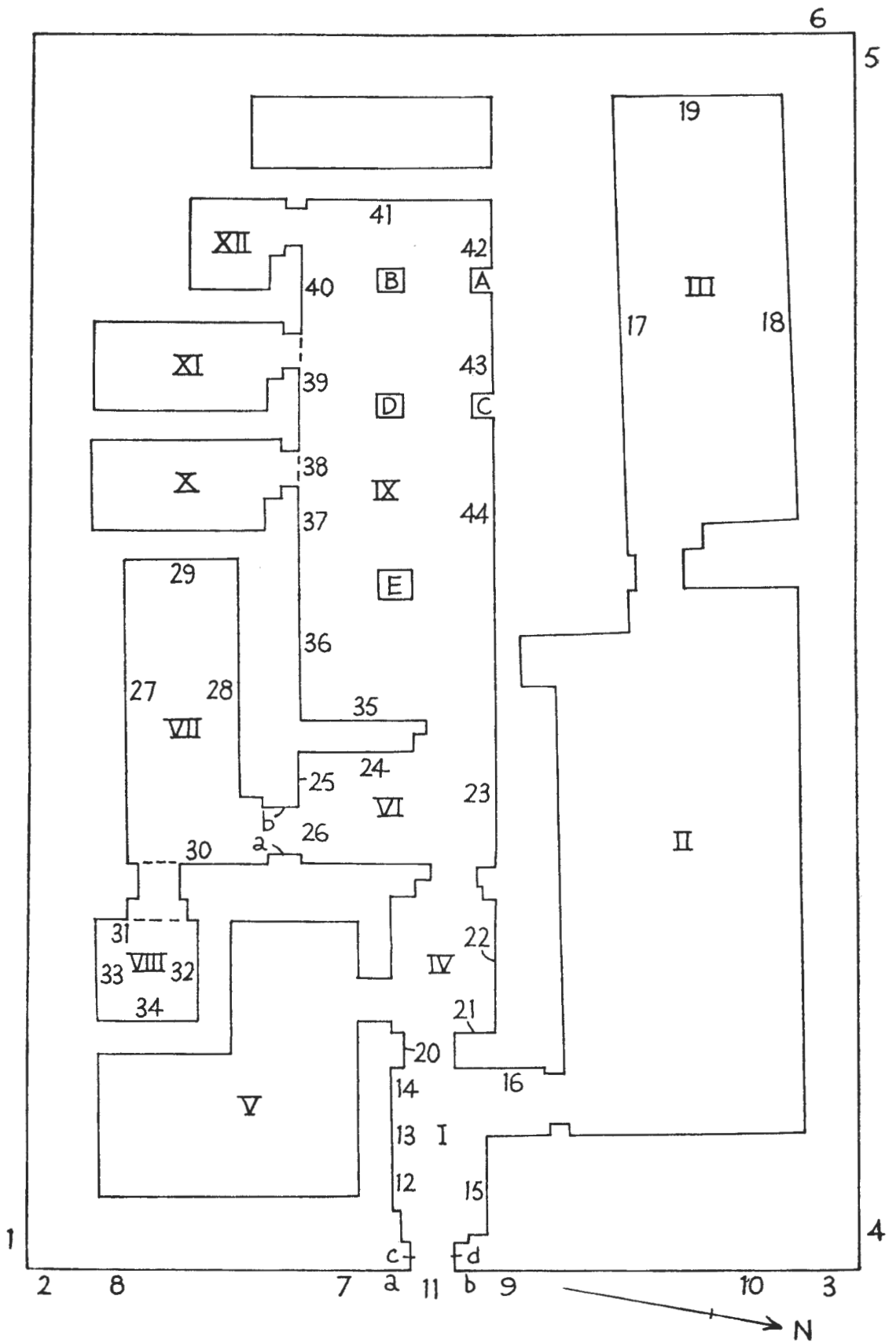

LIII. Şaqqâra. Plan of the tomb of Khentka Ikhekhi. See pp. 508-11.

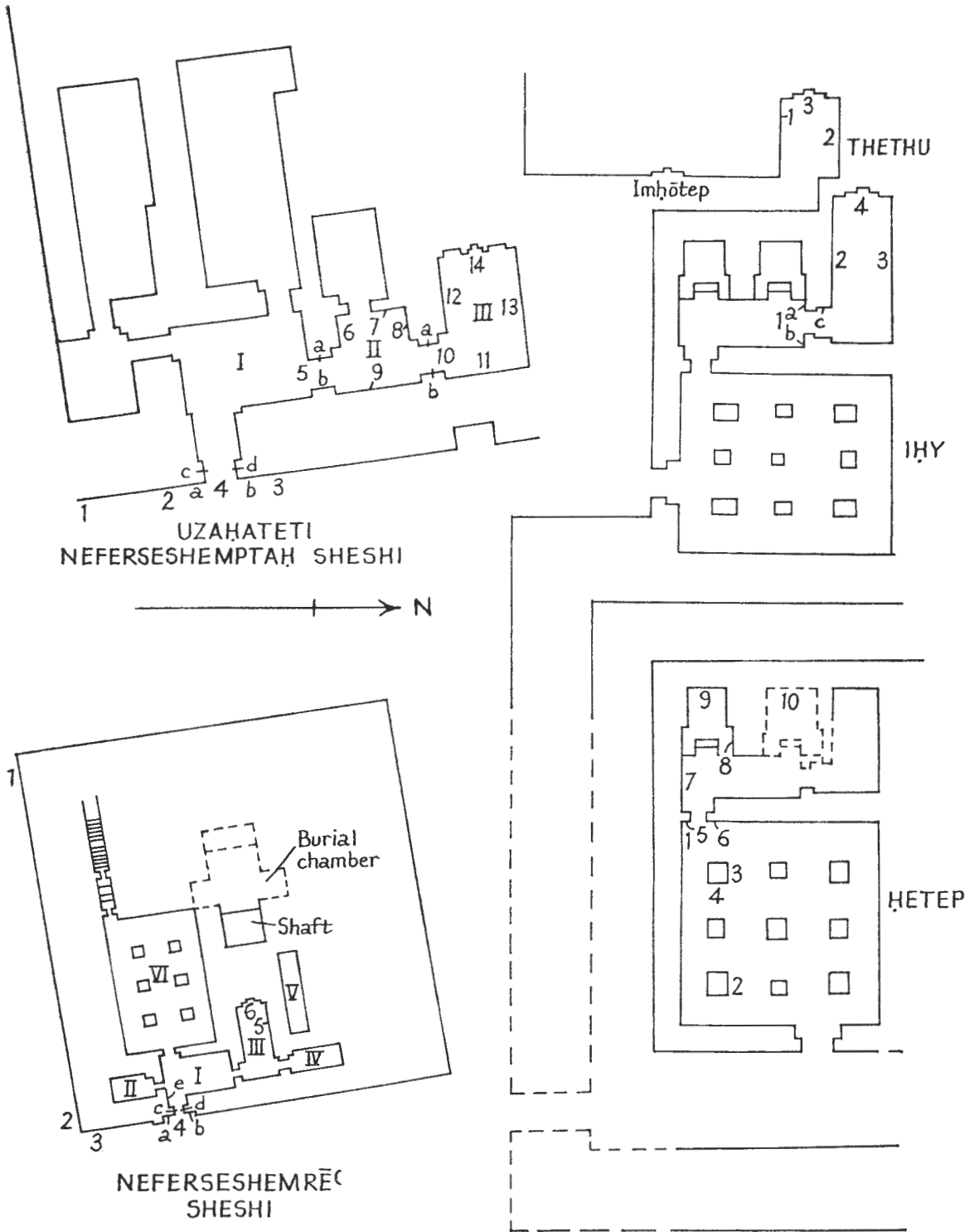

LIV. Şaqqâra. Plans of tombs.

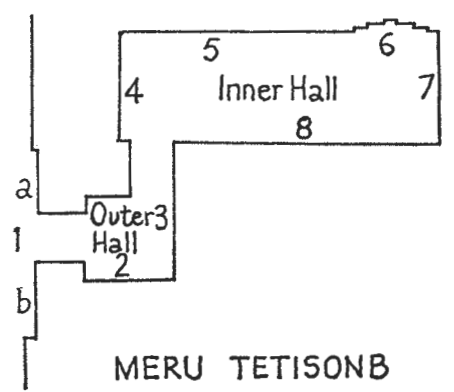
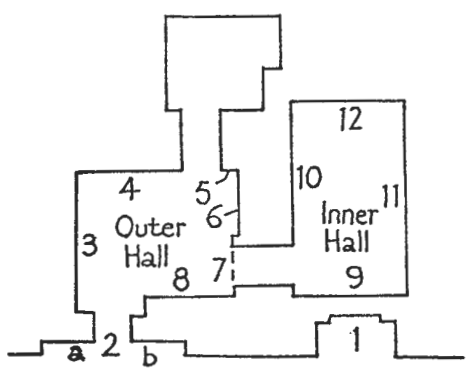
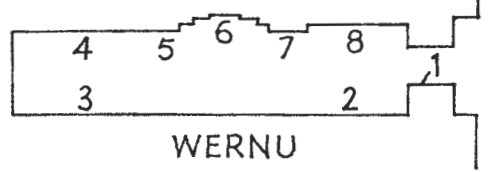
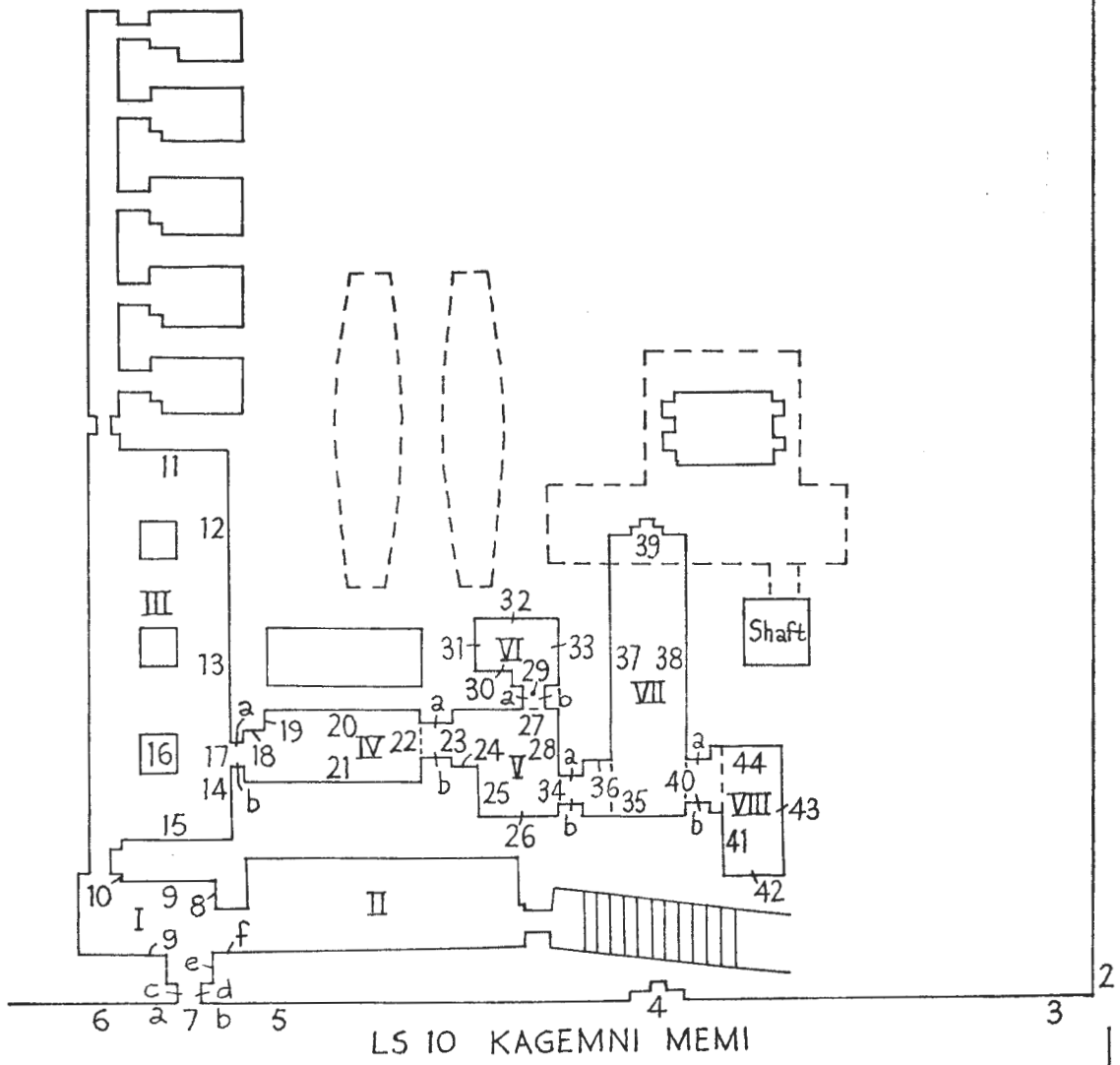

LV. Şaqqâra. Plans of tombs.

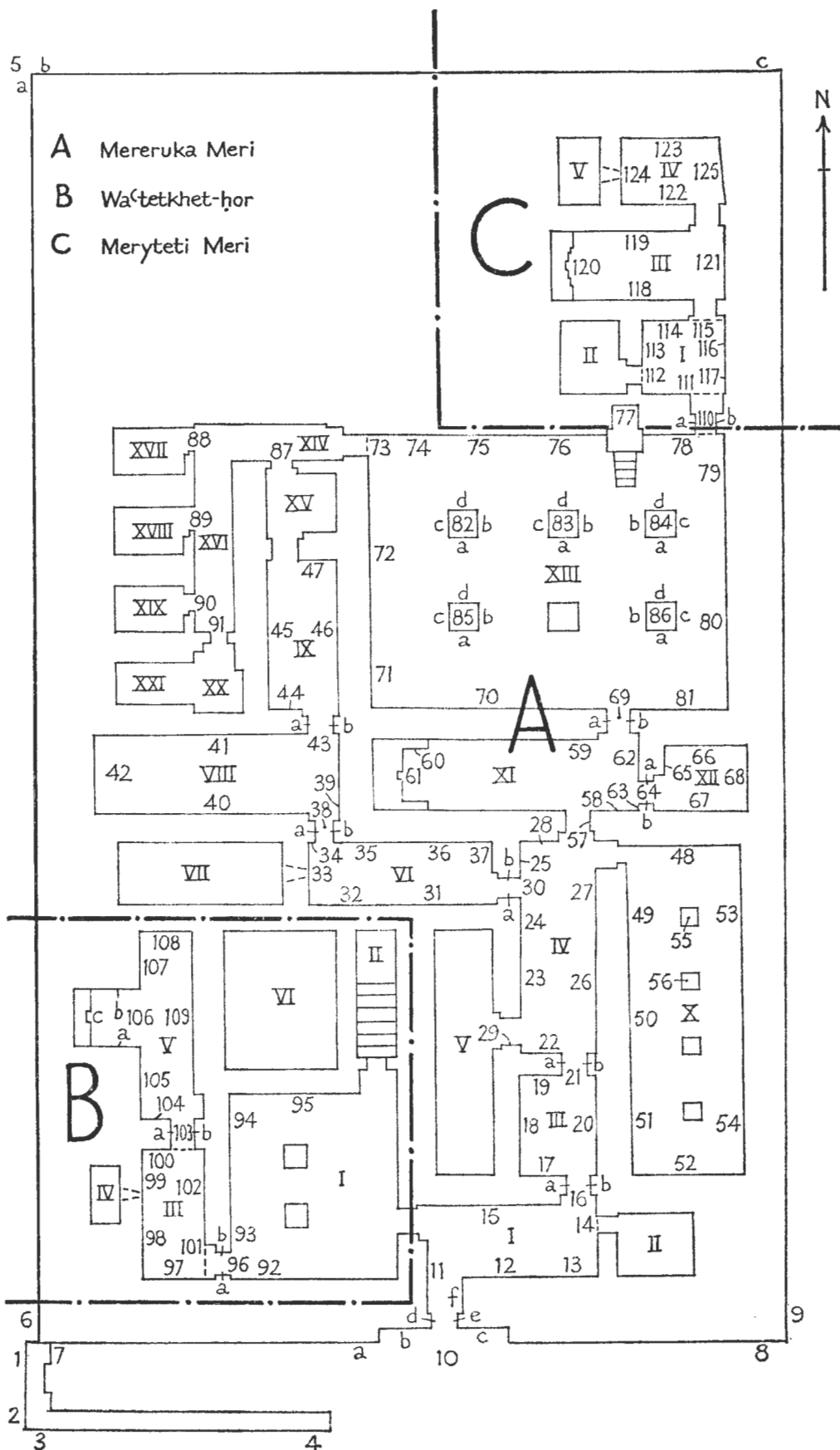

LVI. Şaqqâra. Plan of the tomb of Mereruka Meri. See pp. 525-36.

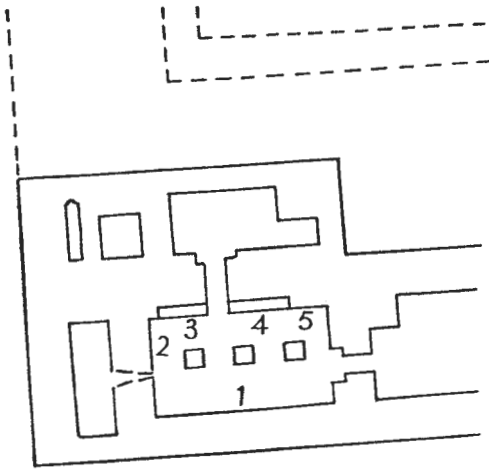

KAEMHĒST

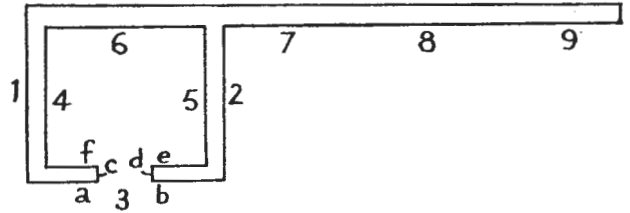

Part reconstructed
in Cairo Museum

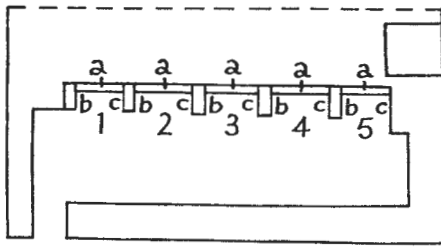

SEKWASKHET

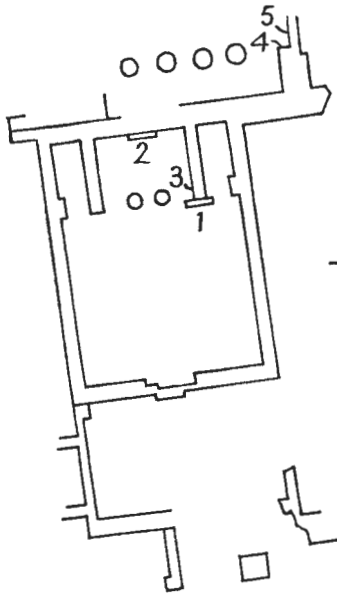

S 2730 and 2736

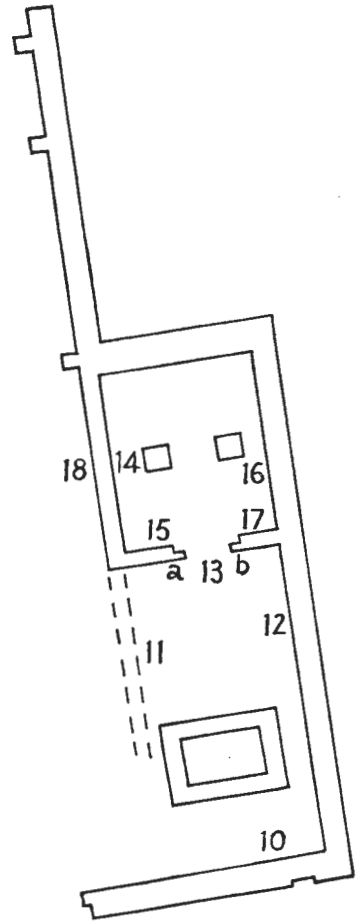

Blocks included in reconstruction
by Anthes
MOSI

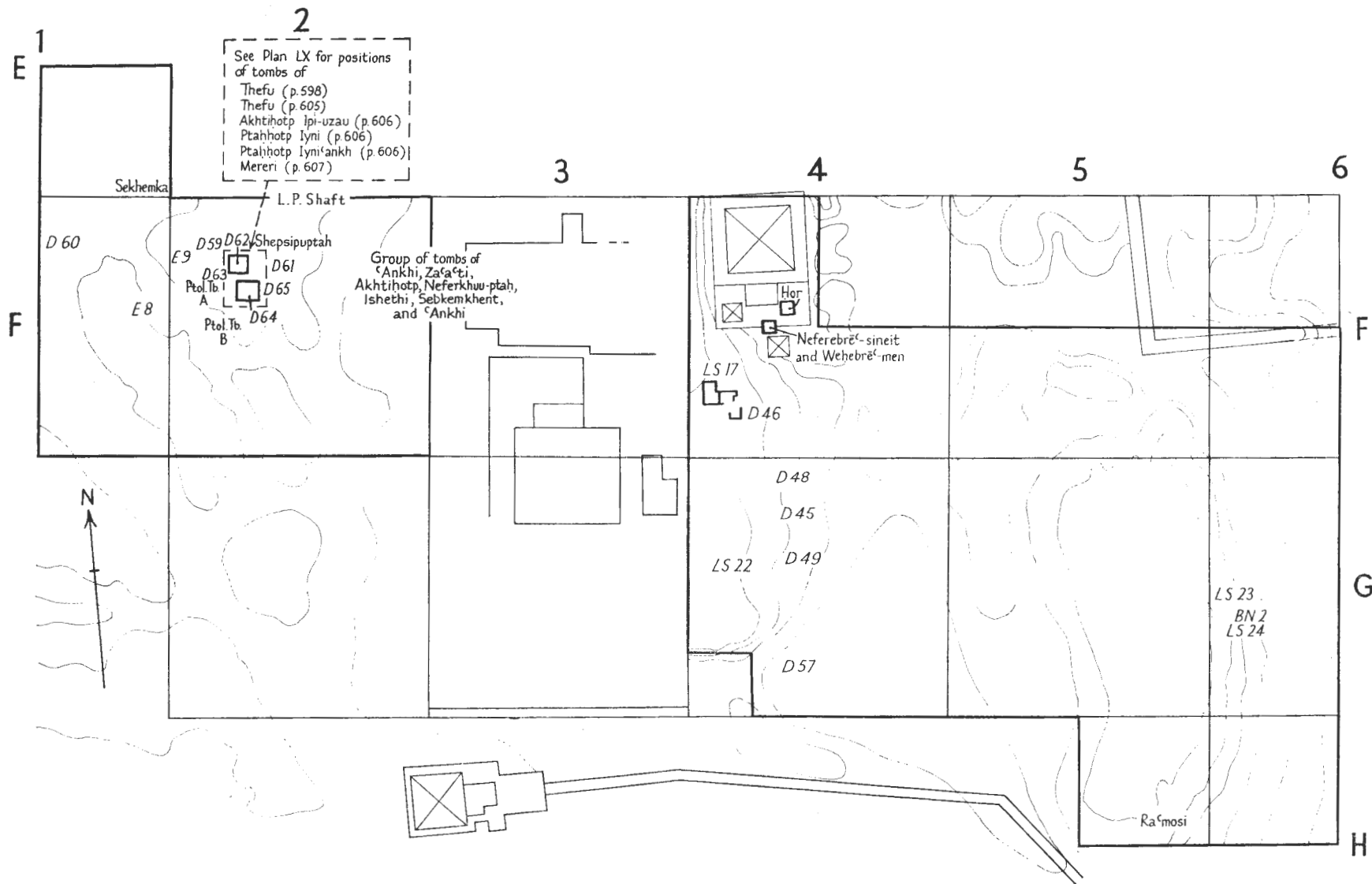

LVIII. Şaqqâra. East and west of the Step Pyramid. See pp. 575-613.

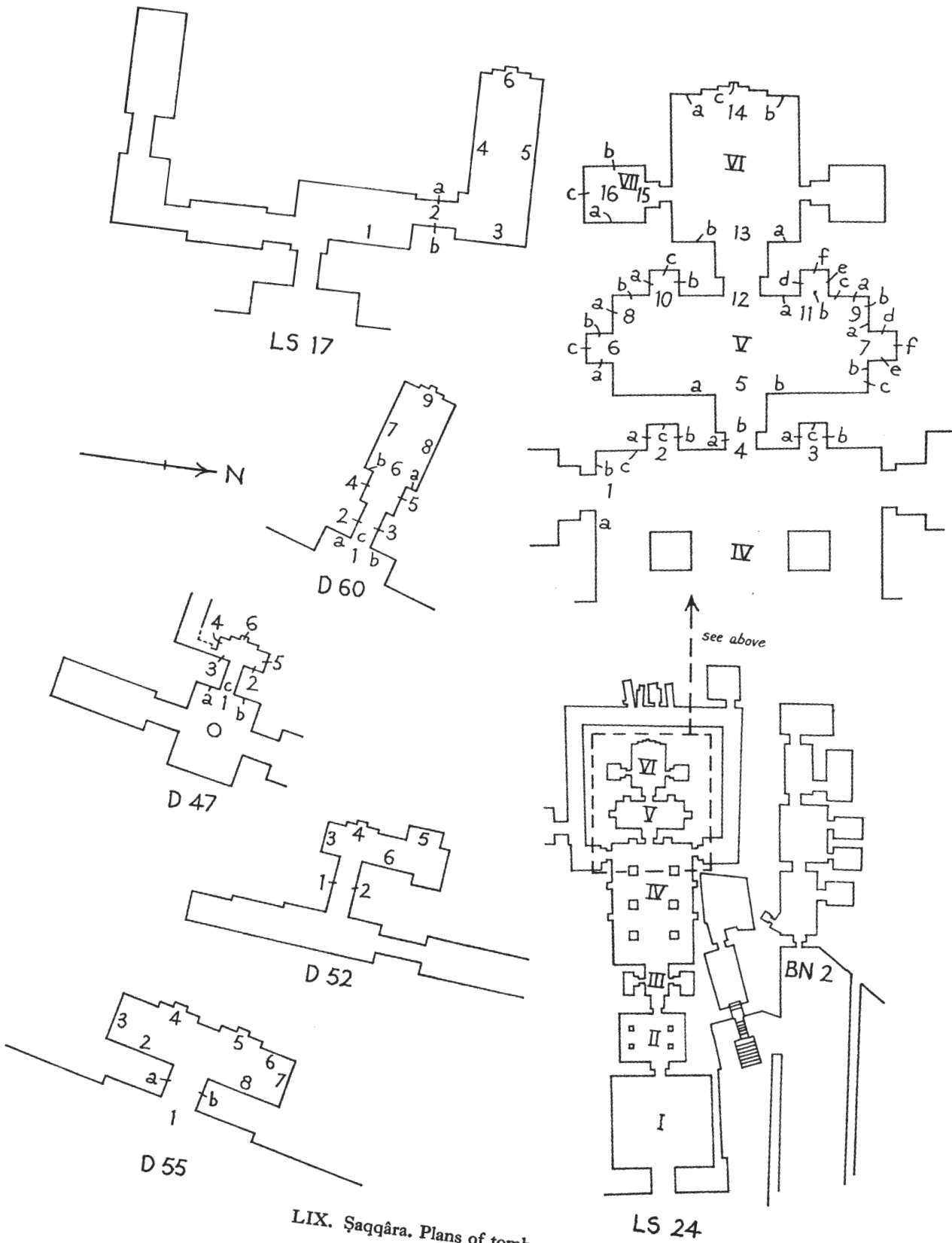

LIX. Şaqqâra. Plans of tombs.

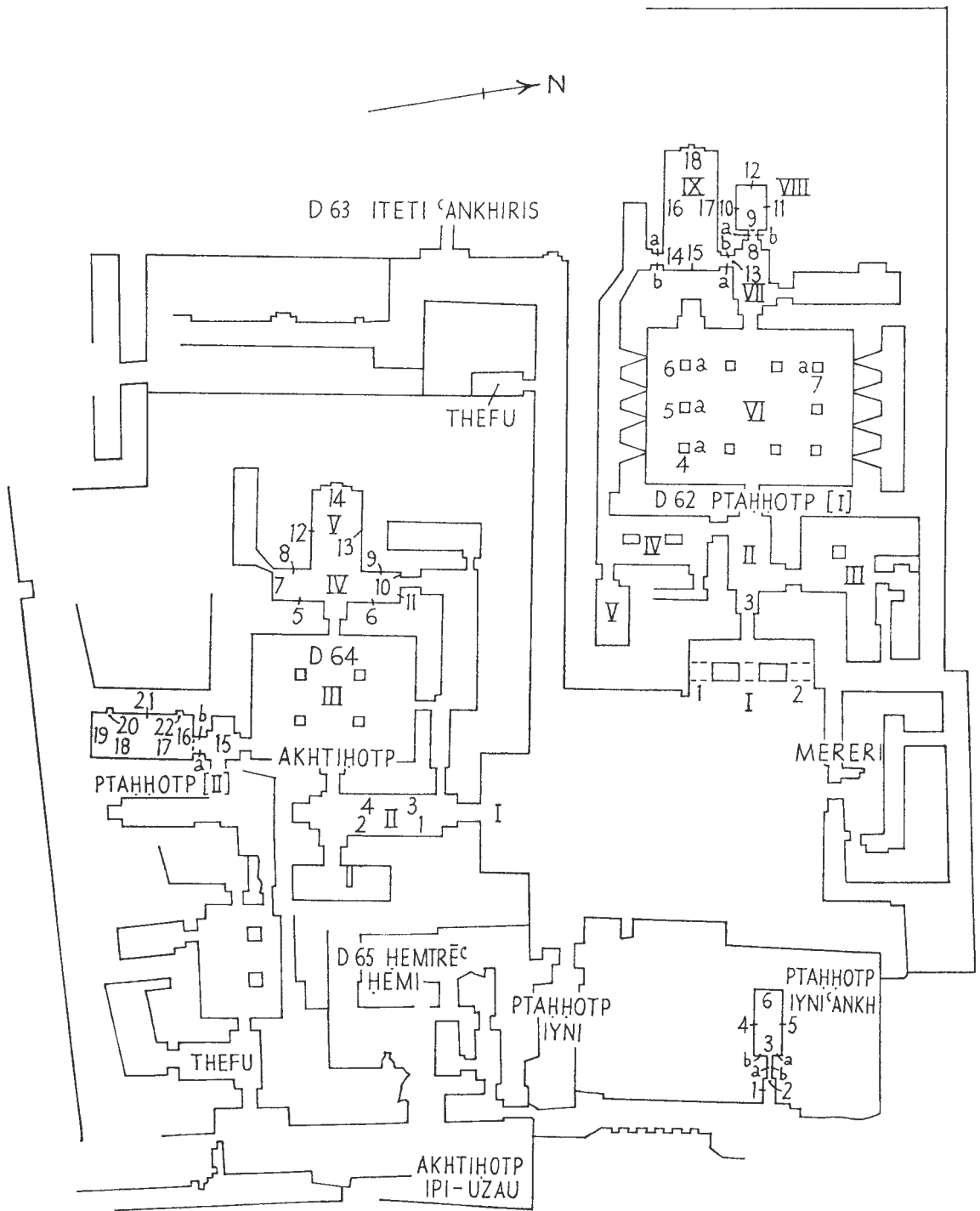

LX. Şaqqâra. A group of tombs west of the Step Pyramid. See map LVIII and pp. 596-608.

Step Pyramid Enclosure

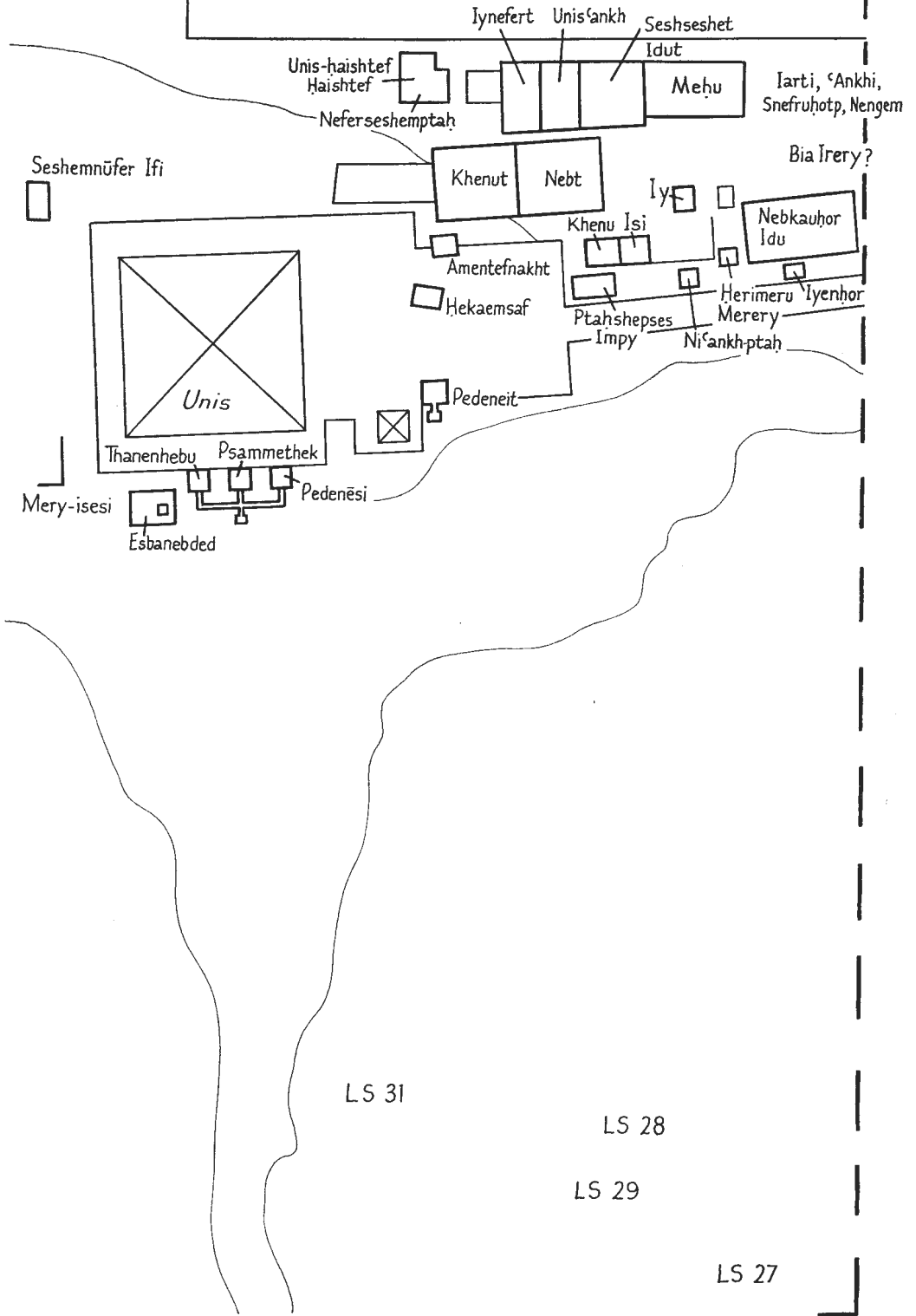

LXI. Şaqqâra. Around the Pyramid-complex of Unis and between the Monastery and Sekhemkhet's Enclosure (west section). See pp. 613-71.

Map LXI adjoins

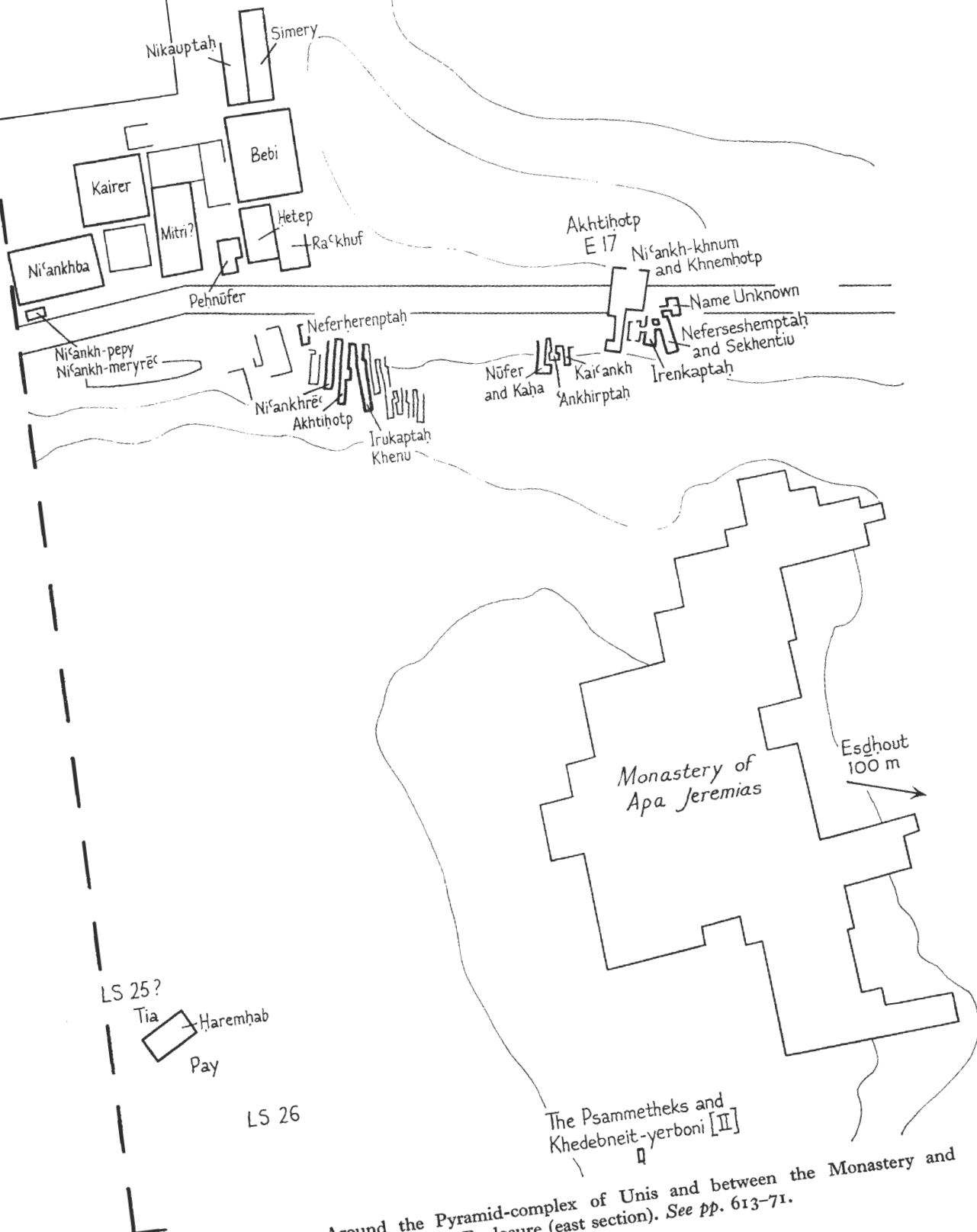

LXII. Şaqqâra. Around the Pyramid-complex of Unis and between the Monastery and Sekhemkhet's Enclosure (east section). See pp. 613-71.

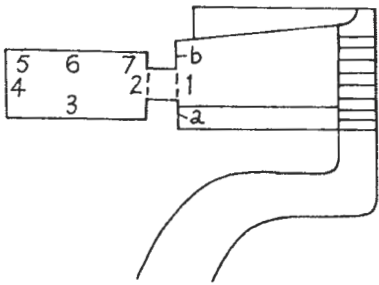

SESHEMNÜFER I FI

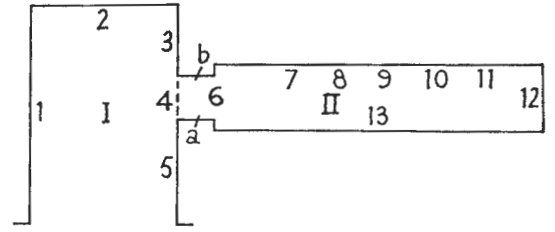

UNIS-ĤAISHTEF

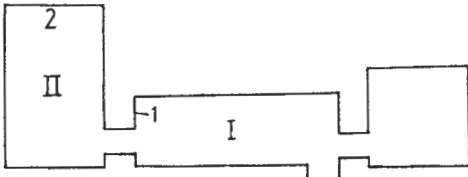

MERY-ISESI

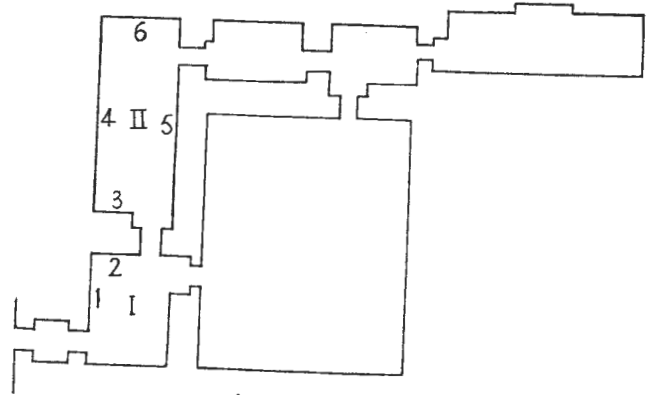

UNIS^cANKH

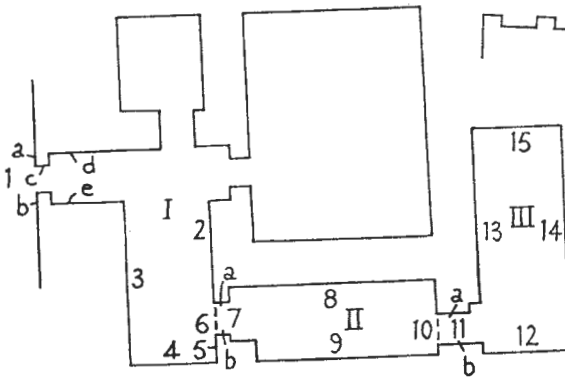

IYNEFERT

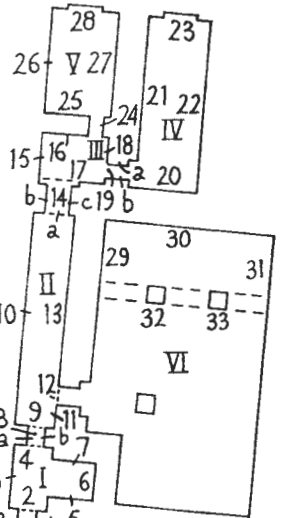

MEĤU

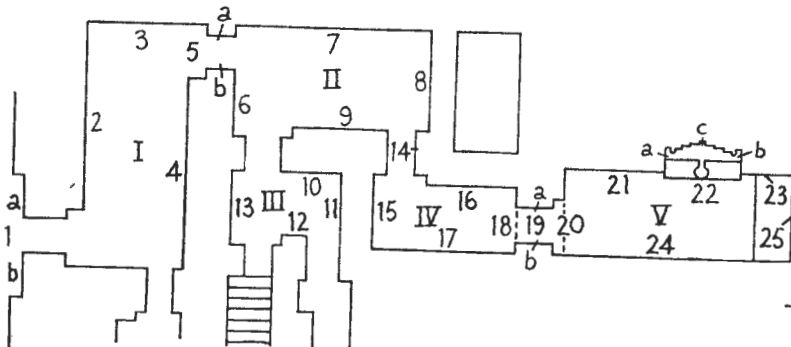

SESHSESHET, IDUT



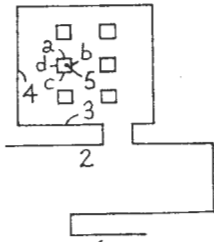
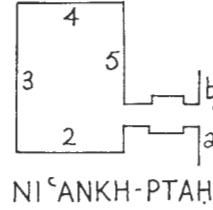
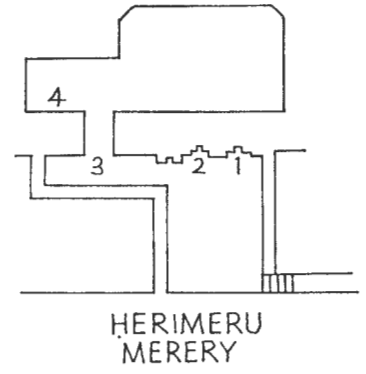
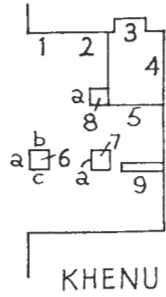
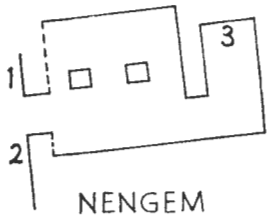

PTAHSHEPSES IMPY

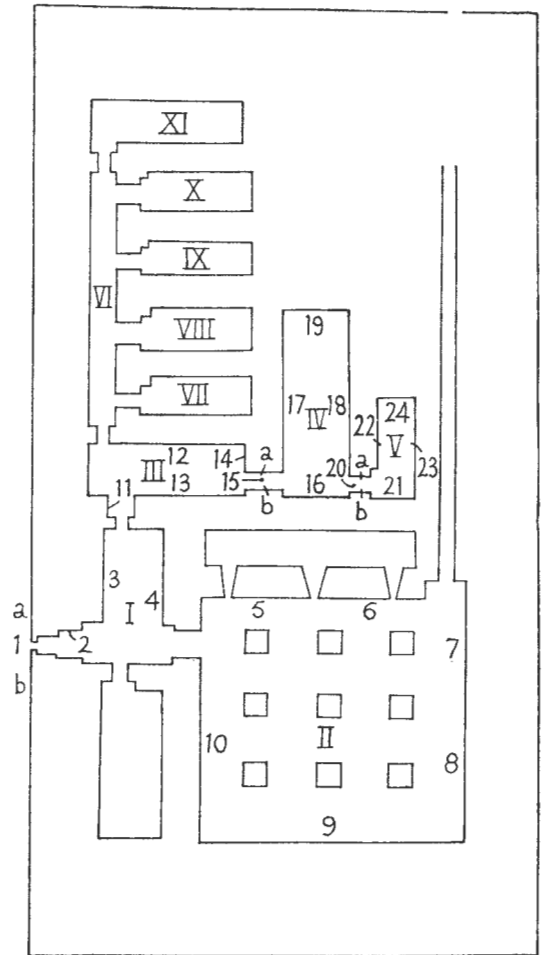
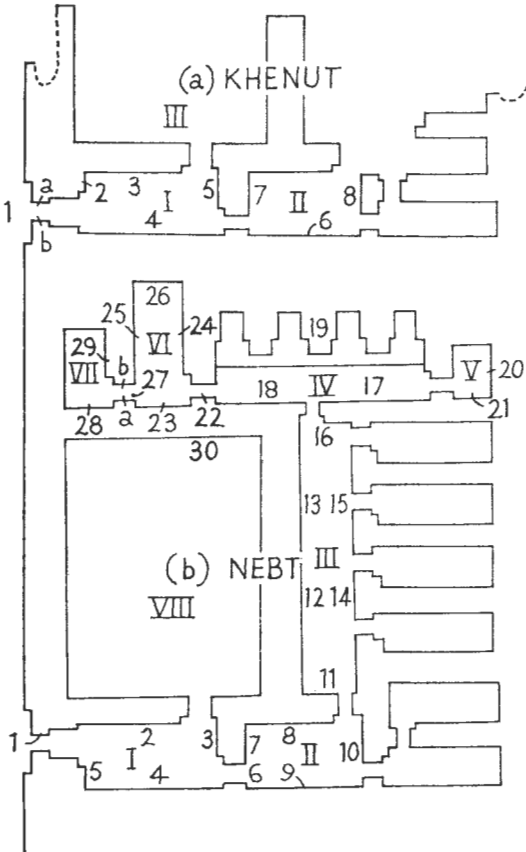

NEBKAUHOR IDU

LXIV. Şaqqâra. Plans of tombs.

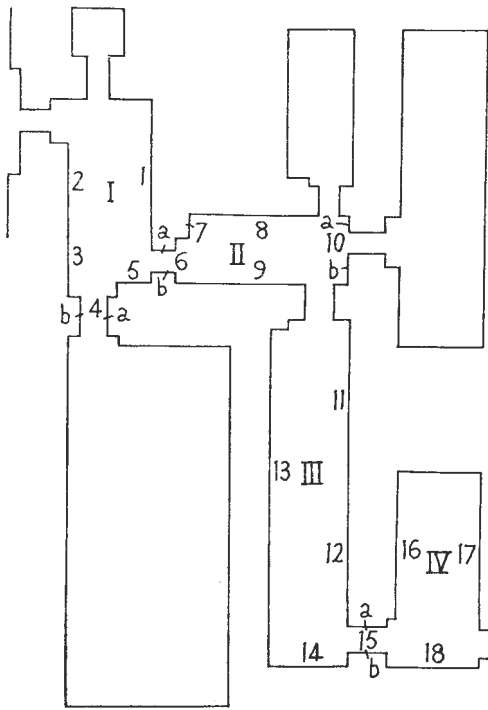

KAIRER

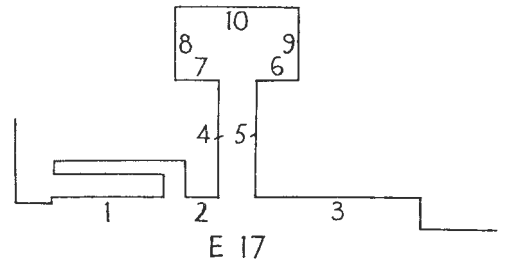

NEFERHERENPTAḤ

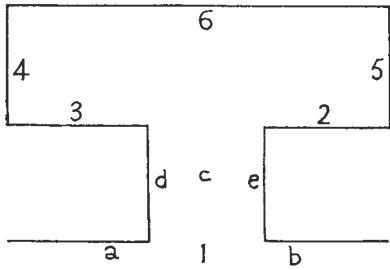

AKHTIḤOTP

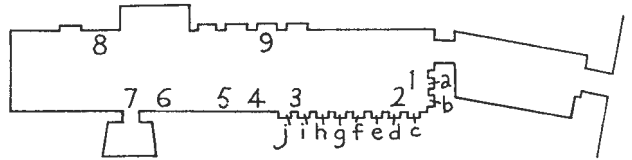

IRUKAPTAḤ KHENU

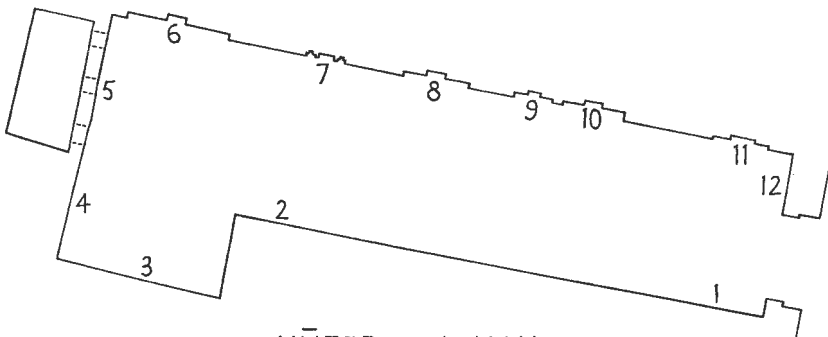

NŪFER and KAḤA

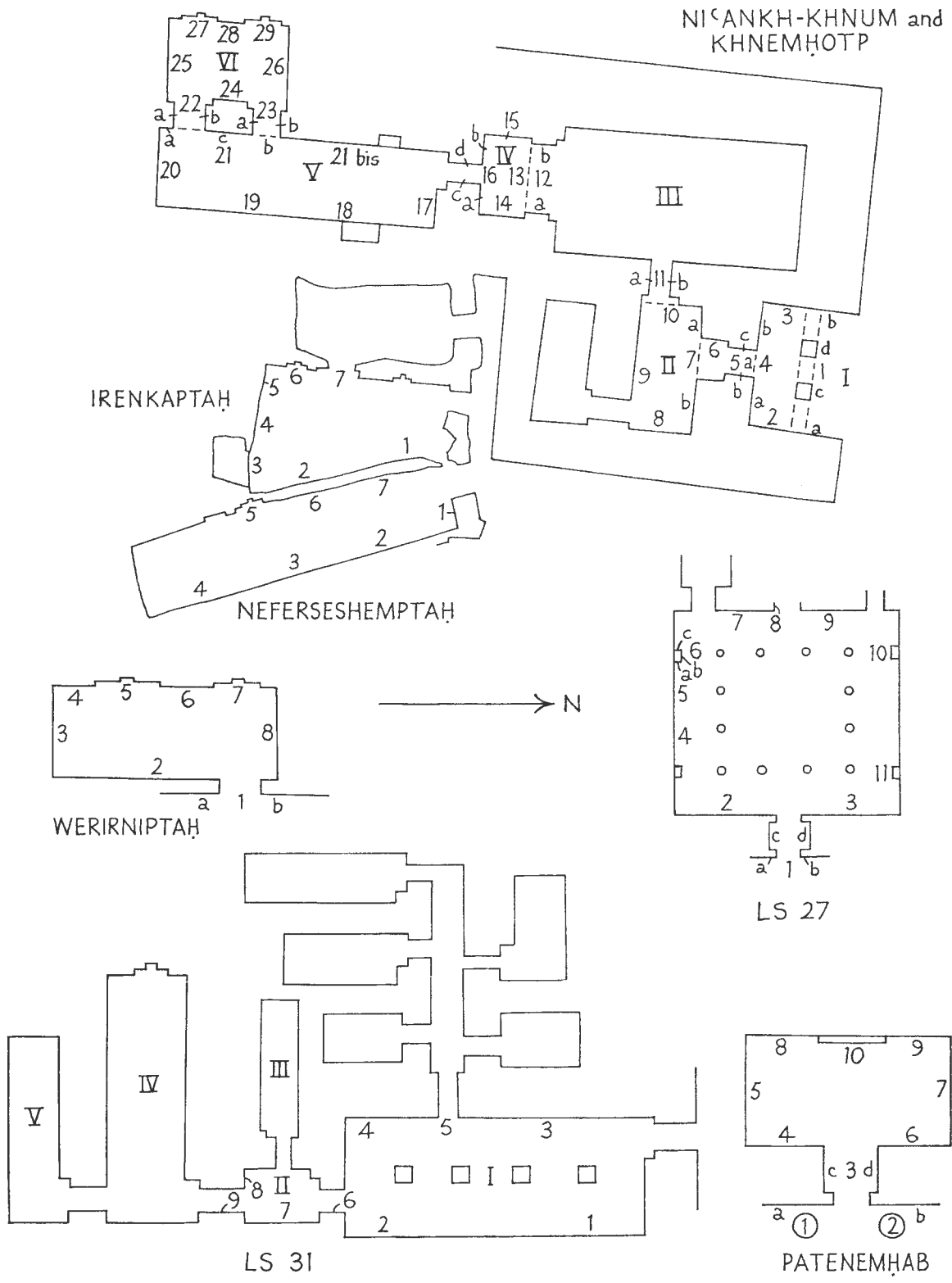

LXVI. Şaqqâra. Plans of tombs.

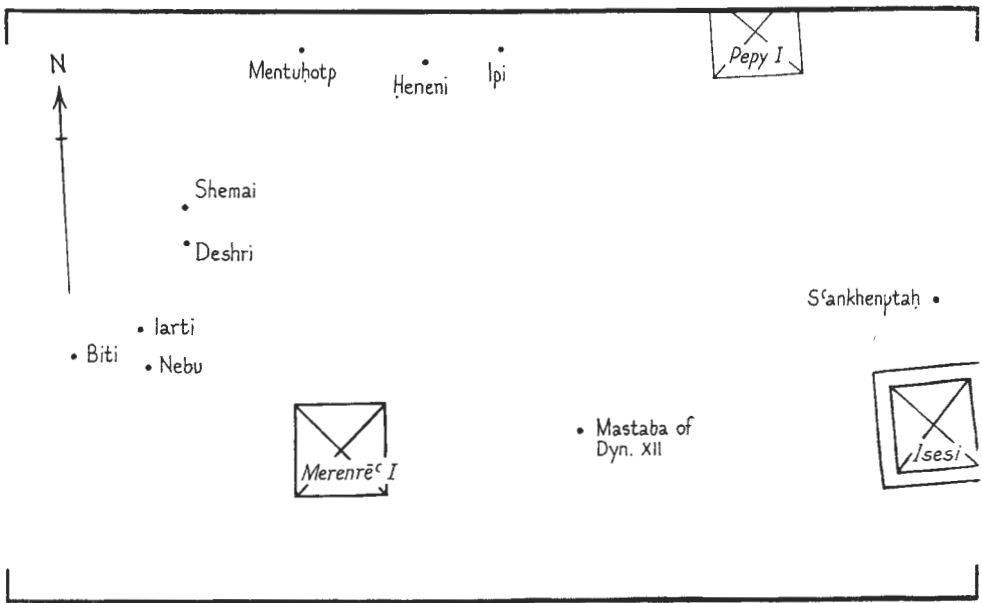

[1]

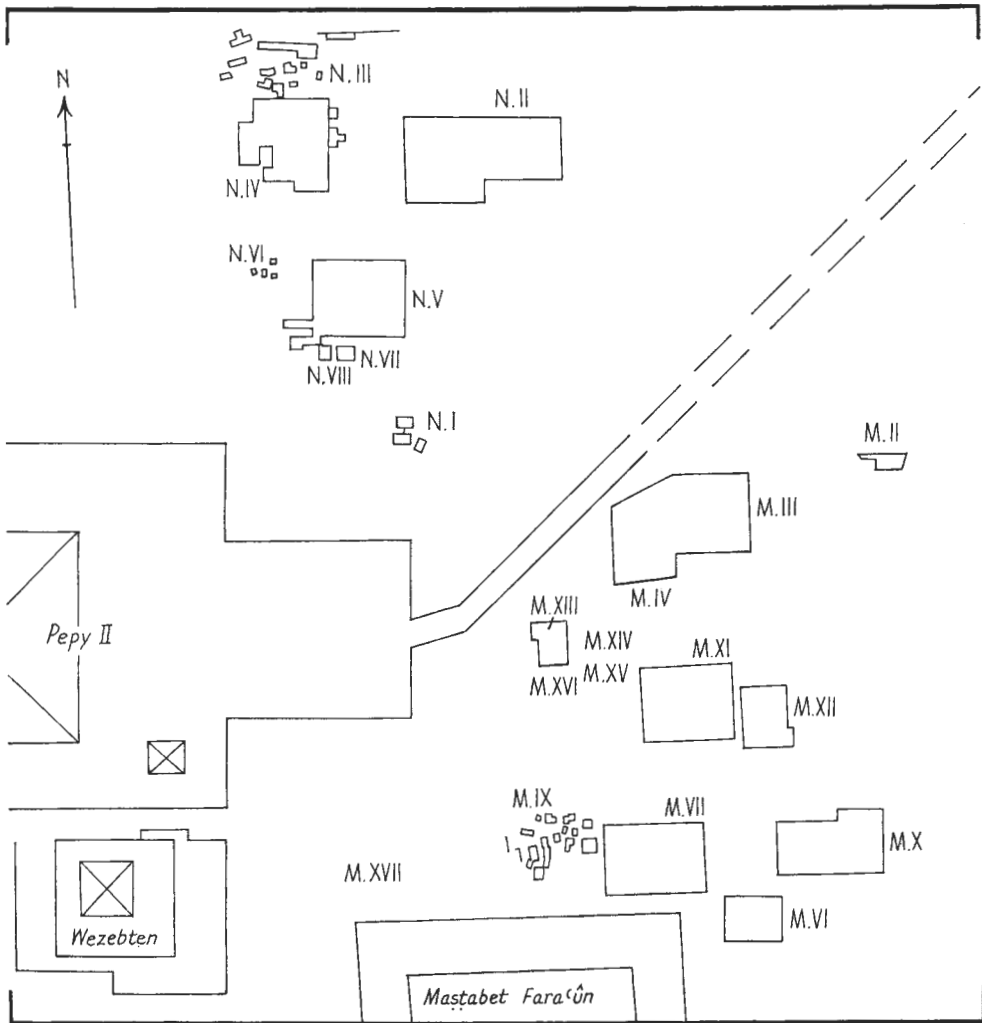

[2]

LXVII. Şaqqâra.

1. Around Pyramids of Pepy I, Merenrê I, and Isesi. See pp. 671-4.
2. North-east and east of Pyramid of Pepy II. See pp. 676-85.

LXVIII. Şaqqâra.
 Sacred Animal Complexes.
 Western Group with
 the Serapeum.
 See pp. 778-820.

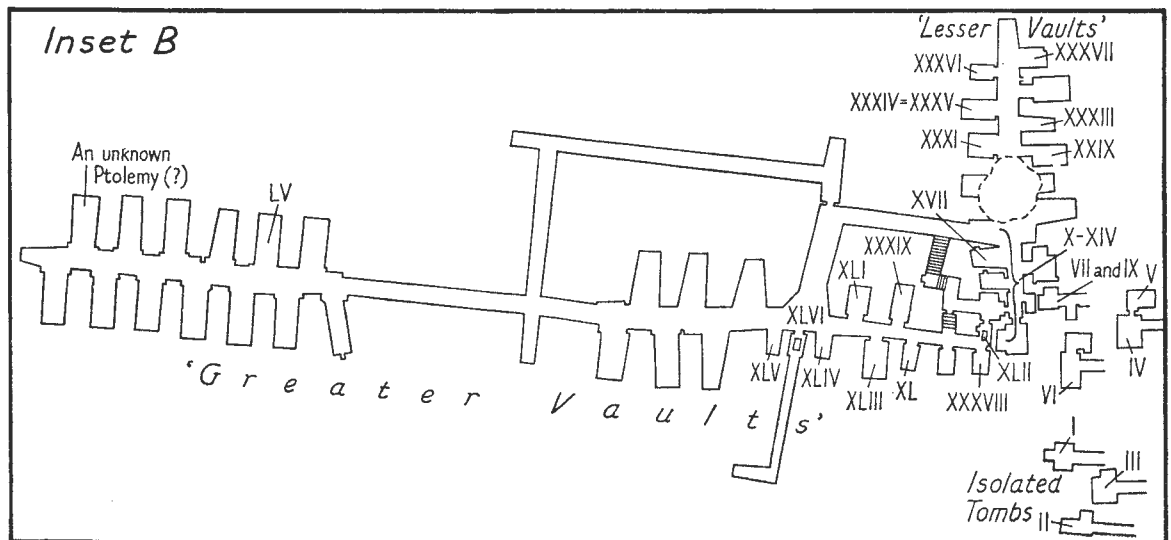
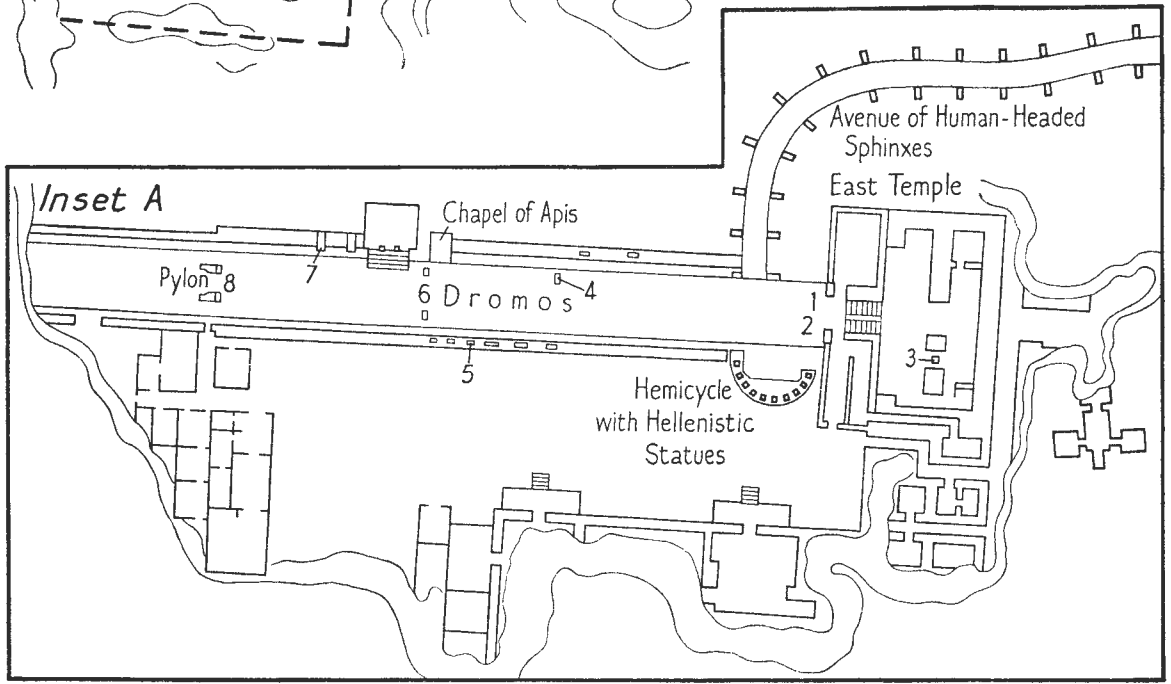
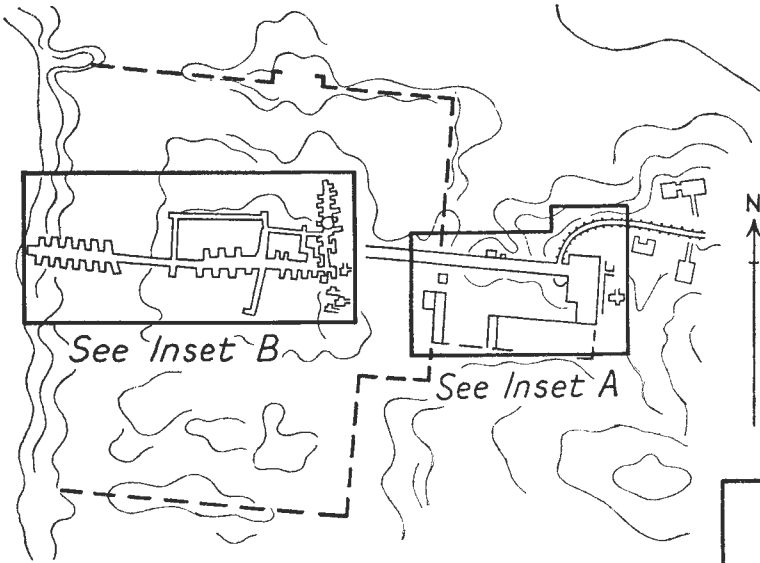

LXIX. Şaqqâra.
Sacred Animal Complexes (west section).
See pp. 777-827.

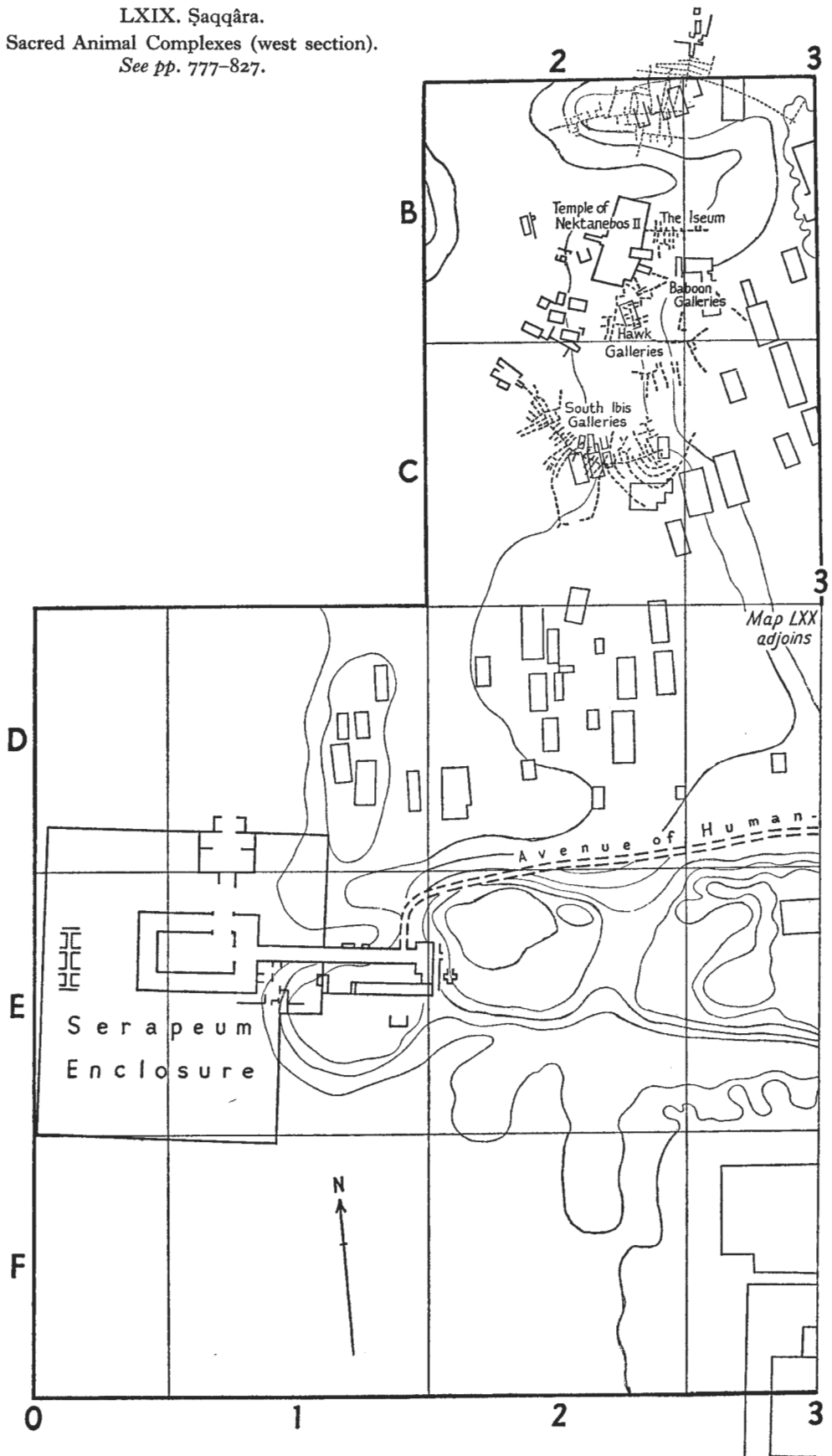

LXX. Şaqqâra. Sacred Animal Complexes (east section). See pp. 777-827.

Areas D/E-5/6 have been corrected according to the plan published by Smith (H. S.) and Jeffreys in *J.E.A.* 64 (1978), fig. 1 on p. 14.

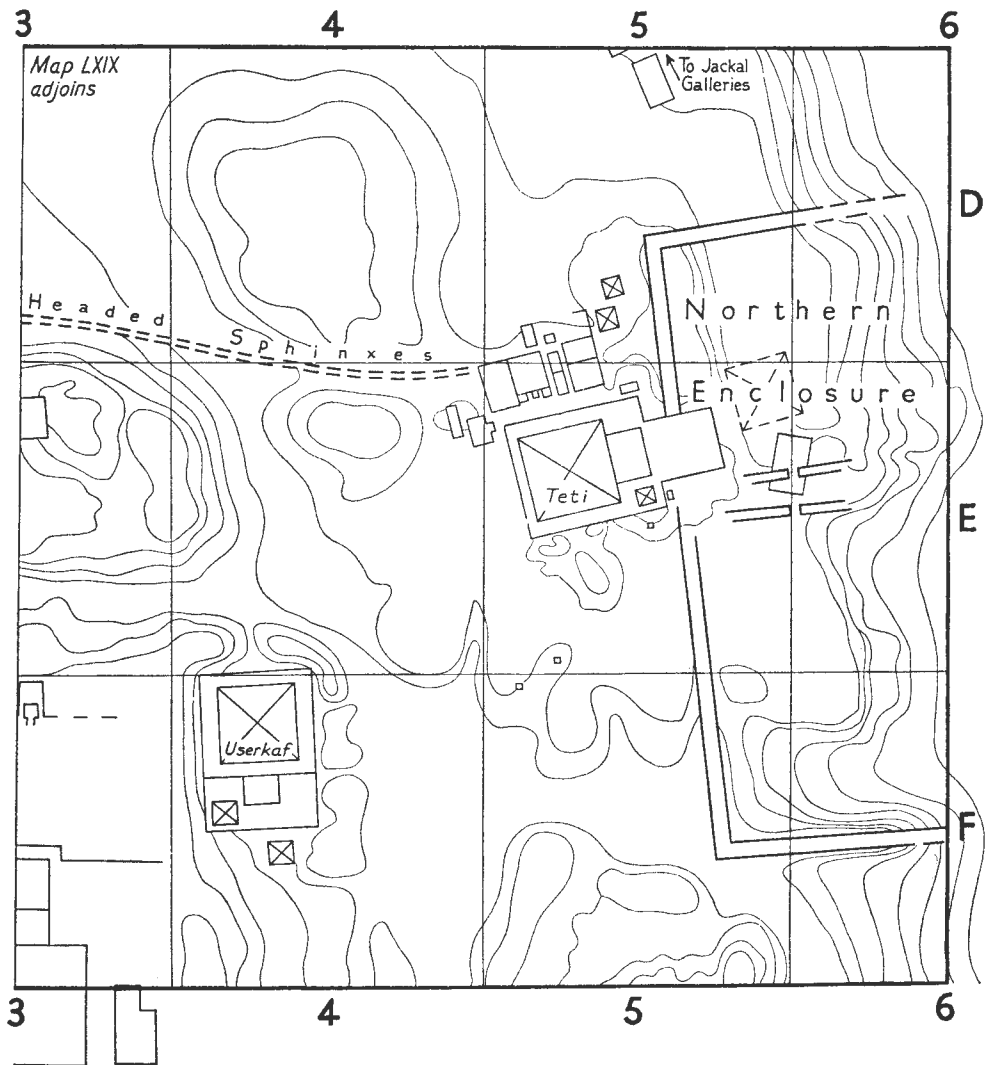

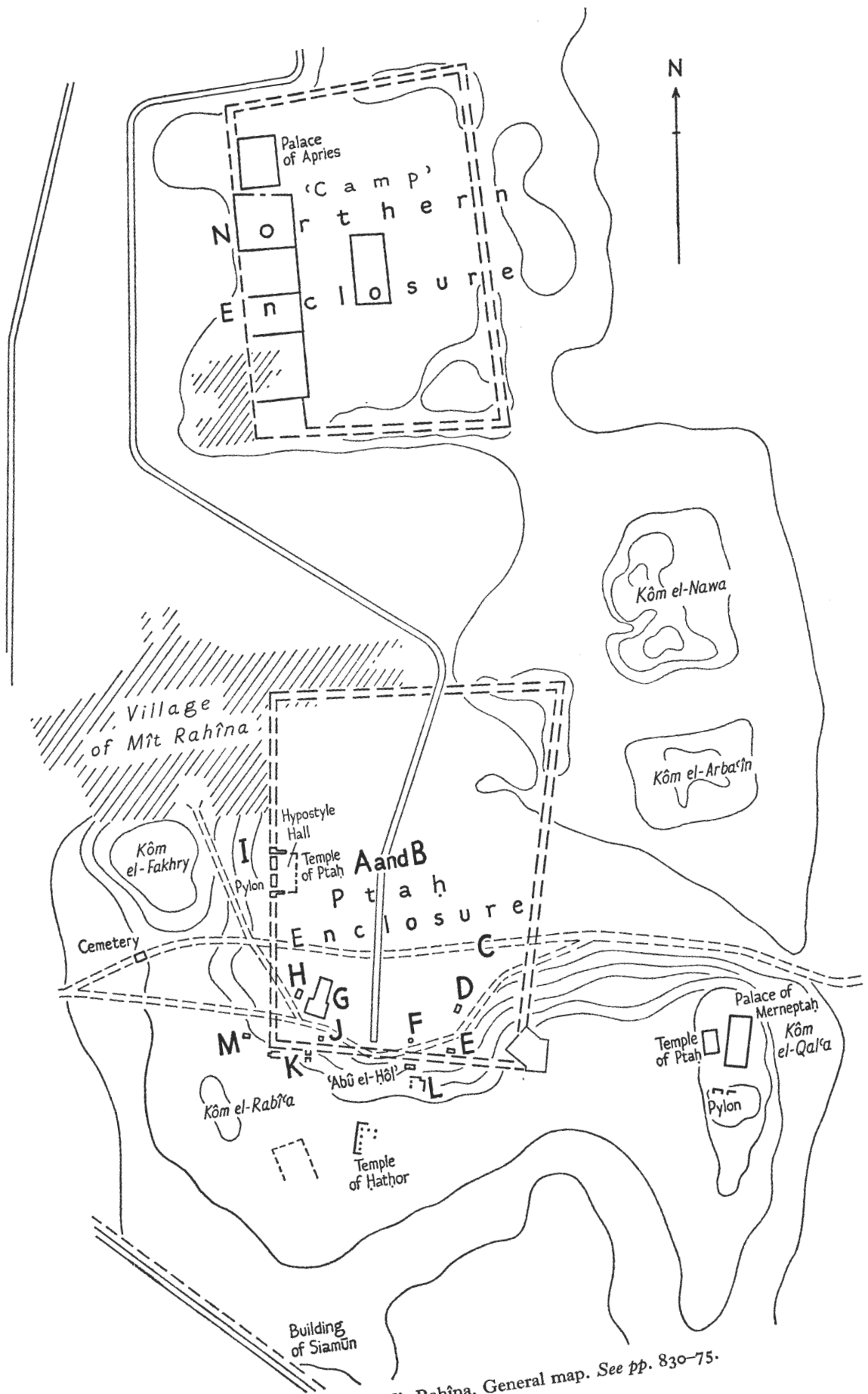

LXXI. Mît Rahîna. General map. See pp. 830-75.

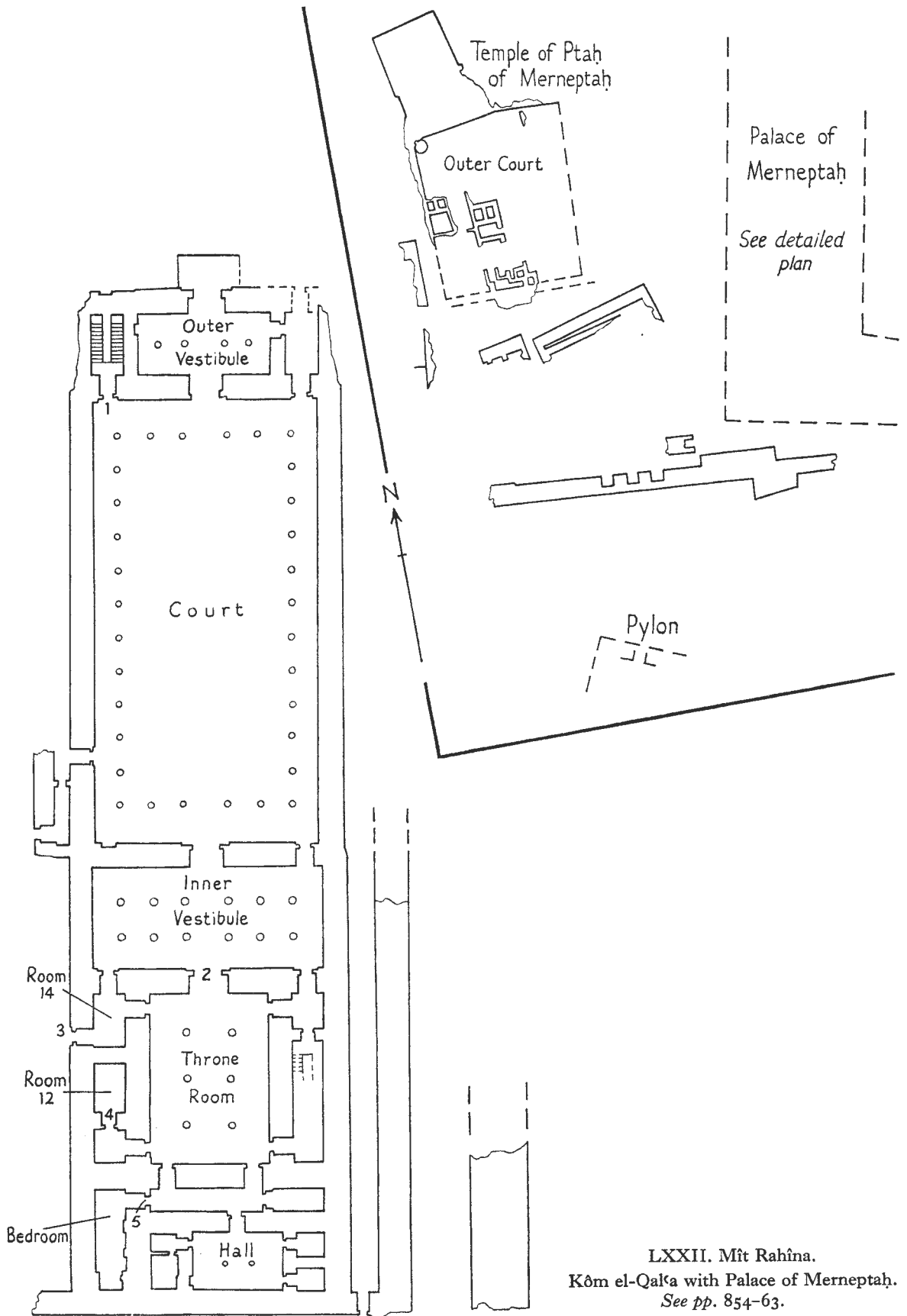

LXXII. Mît Rahîna.
Kôm el-Qal'â with Palace of Merneptah.
See pp. 854-63.

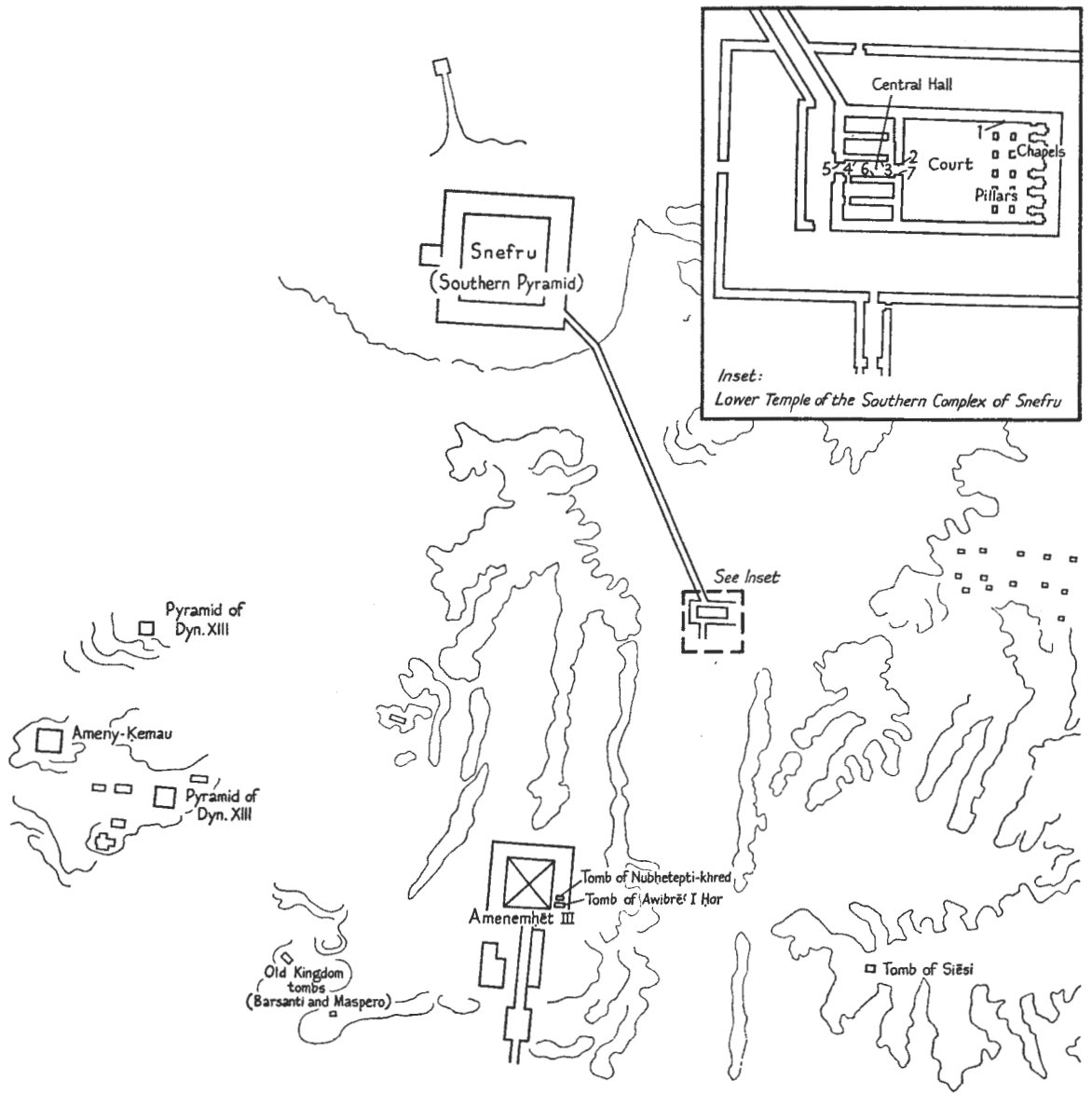

Map LXXIV adjoins

LXXIII. Dahshûr. General map (south section). See pp. 876-99.

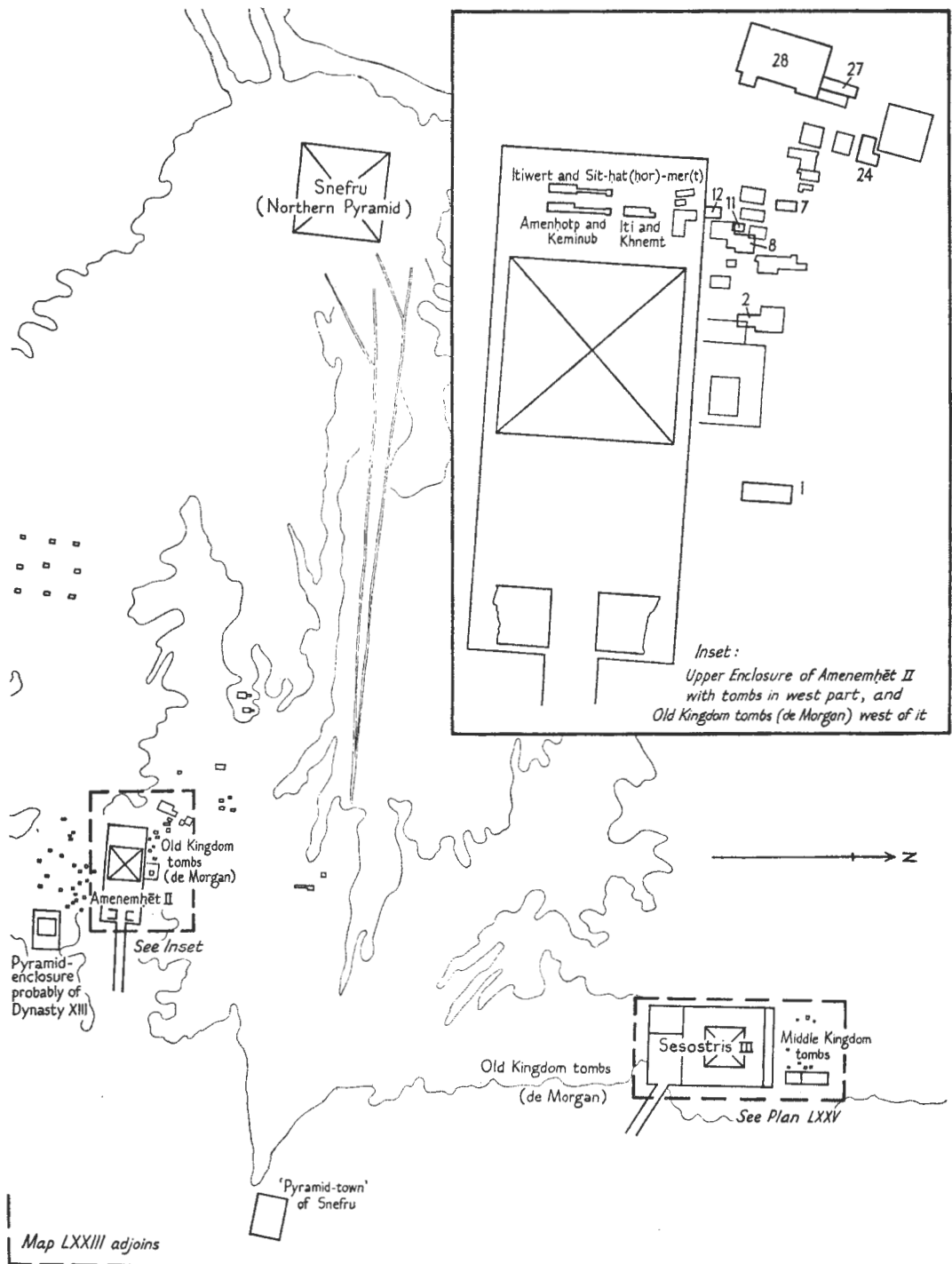

LXXIV. Dahshûr. General map (north section). See pp. 876-99.

LXXV. Dahshûr.
 Pyramid-complex of Sesostris
 III and Middle Kingdom
 tombs north of the enclosure.
See pp. 882-5, 896-8.

