

International Armoured Vehicles

CONFERENCE

London, 21-22 February 2012

Advancing Swedish Armoured Vehicle Capabilities

Armoured Vehicle Programmes

Rickard O. Lindström

Land Systems Procurement Command

Swedish Defence Materiel Administration (FMV)



Agenda

■ Introduction

- A changing world...

■ Update inventory

- CV90
- MBT 122
- RG32M

■ New Equipment

- ARCHER
- Patgb 360 8x8 (AMV)
- BvS10 MkIIB

■ Summary



A change – in everything...

The Policy of Swedish Security



Possible Environments for Insertion

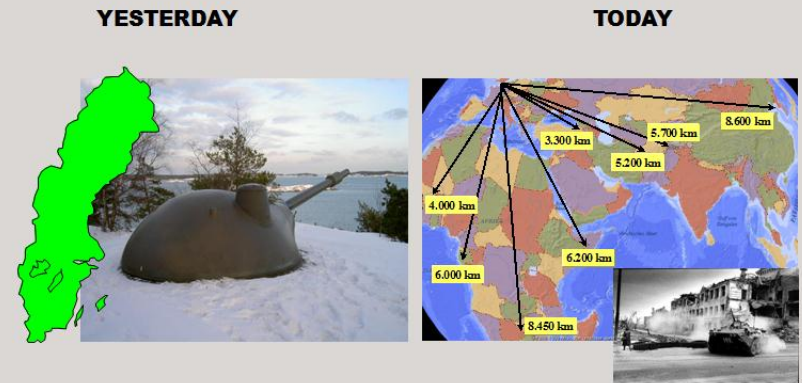

A Dramatic Re-organisation

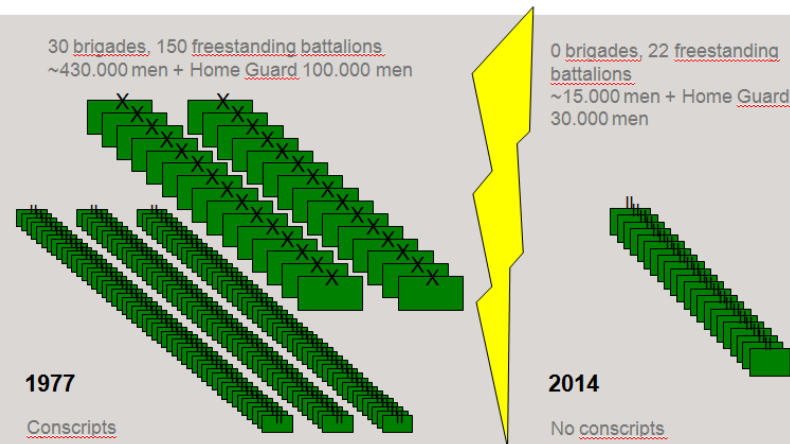

Strategy for Defence Materiel Supply

The model for defence materiel procurement

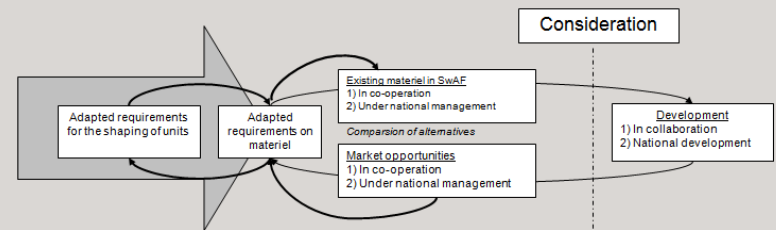

- Equipment in use, not in storage
- Effect today, not tomorrow
- Good enough here and now, not "best in class" in the future
- Interoperability more important than Swedish high-tech
- Short series, rather than long-term development efforts

COMPETITION



DIRECT PROCUREMENT



DEVELOPMENT



1990

2000

2010

FMV



Transformation into fewer AFV systems



2008

2014 - 2020

Current objectives of Swedish Armoured Vehicle programmes

- Armoured Vehicle fleet – update inventory
- Update ongoing activities

CV90



CV90 vehicle family

CV9040

AAV90

FOV90

ARV90

FCV90

EWV90



Plans for renovation & modification



- The CV90 system will go through a renovation programme 2013-2018
- Only minor upgrades foreseen... 400 (out of the 509 CV90s) will be renovated
- A mortar variant based upon the CV90 chassis is being considered

CV90 planned upgrades – highlights



Battery surveillance



New MMI for the driver

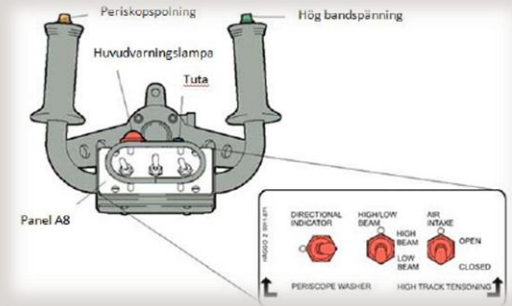

New steering unit



Videosystem with a rear view camera



Extended roof 170 mm at the rear

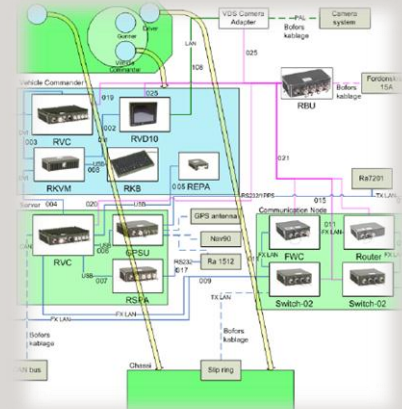

New BMS

CV90 users



Sweden

549 CV9040 in service within the Swedish Armed Forces



Norway

104 CV9030 Mk I in service within the Norwegian Army



Switzerland

186 CV9030 Mk II in service within the Swiss Army



Finland

102 CV9030 Mk II contracted



Netherlands

184 CV9035 Mk III contracted



Denmark

45 CV9035 Mk III contracted

All together 1170 contracted

Rubber band tracks

- Rubber band tracks for heavier armoured vehicles have been look upon for 20 years
- Tests have been performed within the SEP programme & within the CV90 User Club
- Band tracks has been used on two CV9030 by Norway in Afghanistan
- Many advantages:
 - The weight, compared to original steel tracks, can be reduced 1200 kg on a 28000 kg CV90
 - The internal noise level can be lowered 5-10 dB
 - The vibration level can be lowered 50-80%
 - The risk for throwing a track is much lower
 - The traction and side grip is increased
 - The band track is more stable than a steel track
 - Break even cost at 3500 km (including road wheels and band pads), can now be reached
 - Much lower visual signature, i.e. the generation of sand dust thrown up in the air is much lower

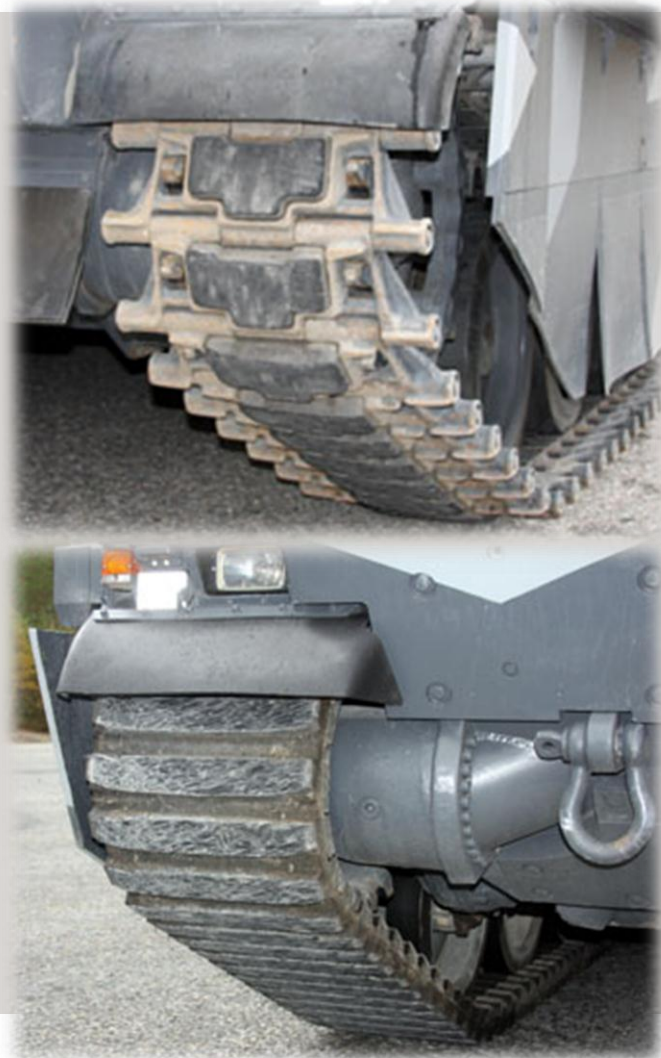

Leopard 2



Leopard 2 vehicle family

MBT 122

ARV 120

AEV 120



MBT 122A and MBT 122B

Strv 122A / Strv 122B

Strv 122A (MBT 122A)

- 106 MBT 122A, 30 in use for training but most of the MBTs are in storage

Strv 122B (MBT 122B INT MiP)

- 14 MBT 122B with mine protection
 - Upgraded with an International Mission Package
 - In storage waiting for deployment

Prepared for international mission

- Including the upgraded ARV 120



Upgrading programme

- An upgrading programme is planned from 2013
- The plan is to upgrade 74 of the 120 Strv 122 – but this figure can be changed
- Upgrading is mostly a renovation
- Only minor modifications:
 - A new Battle Management System (separate cost for this)
- Enhanced protection evaluated to be partially included in the upgrading package





MBT 122B+

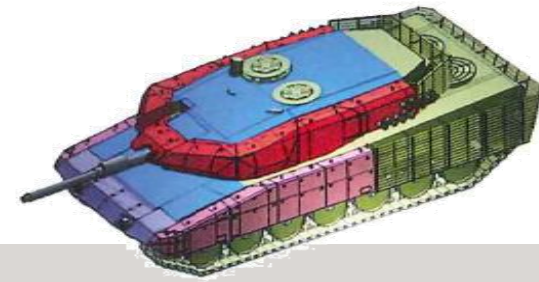

Strv 122B+ (MBT 122B+)

- A prototype produced during 2010-2011 by IBD (Akers in Sweden)
 - Using a new type of “SLAT” armour with nano technology
- Meeting “the new” diversified threat for urban warfare (full spectrum)
 - EFP, RPG, IED, 360°
- Challenges:
 - Increase the weight as little as possible
 - Keep the width of the vehicle (4m)
- Outcome:
 - 350 kg added weight

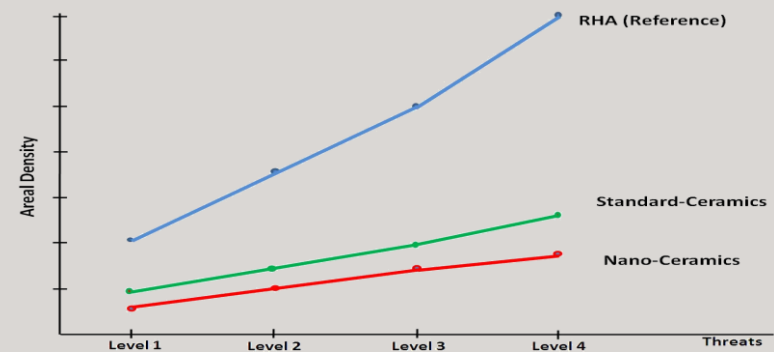

RG32M



RG32M (Ptgb6) 4x4

- The first batch of the RG32M 4x4 (102 vehicles) was ordered in 2004
- The second batch, additional 98 vehicles, was ordered in 2006
- Due to experiences in AFGH, it was decided that these vehicles needed to be upgraded to an IASF configuration (2009-2011)
- A third batch (60 vehicles) is upgraded to the same standard during production
 - ordered 2008, upgraded 2010-2011
- A 4th batch of 120 vehicles planned for deliveries starting 2012



ISAF "Fast Track" – RG32M modifications

- New axles to allow additional 1500 kg loading capability
- Modifications in the drive train
- New wheels and tires (+CTIS)
- Improved fire extinguishing
- Integration of a Plat Ringmount
 - Prepared for ROWSS
- New communication system
- Integration of a new floor
- Extra lights (including IR)
- Multispectral camouflage kit



Ongoing AFV procurement

- Self-propelled Artillery System
- Armoured Wheeled Vehicle
- Tracked Articulated All-Terrain Vehicle

ARCHER



REMO haubits 77B ARCHER



Volvo A30E Dumper



Weapon from haub 77B

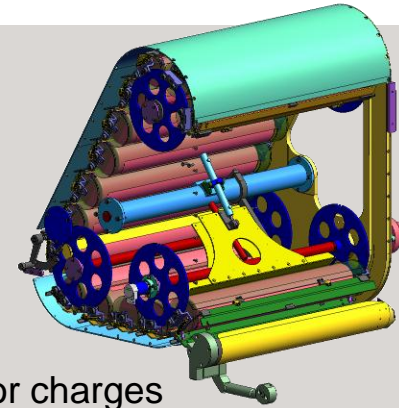

Magazine for charges and grenades



Splinter and mineprotected cabin

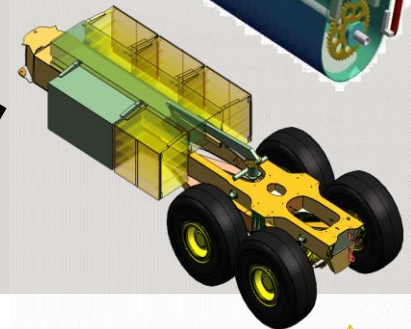
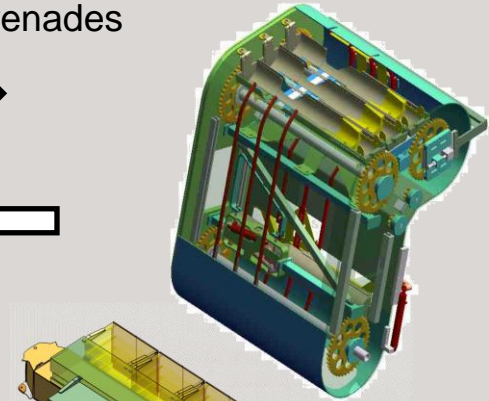

The ARCHER project

- Technology studies of FH 77A MLU 1995-1998
- Technology studies of FH 77B MLU 1998-2003
- ARCHER feasibility study 2004-2006
- Product Definition Phase 2006-2007
- Design and Demonstration Phase 2006-2009
- Production Phase 2010-2014
- First delivery to the Swedish Army 2012
- First delivery to the Norwegian Army 2012
- In parallel new 155 mm ammunition has been developed - EXACALIBUR



Swedish – Norwegian Indirect Fire Cooperation

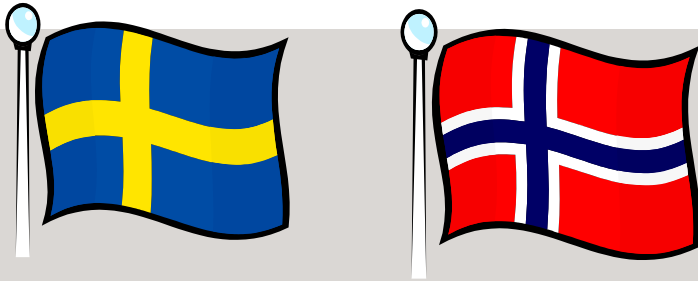

**Memorandum of Understanding
Indirect Fire**

- ✓ Affordability
- ✓ Economies of scale
- ✓ Interoperability

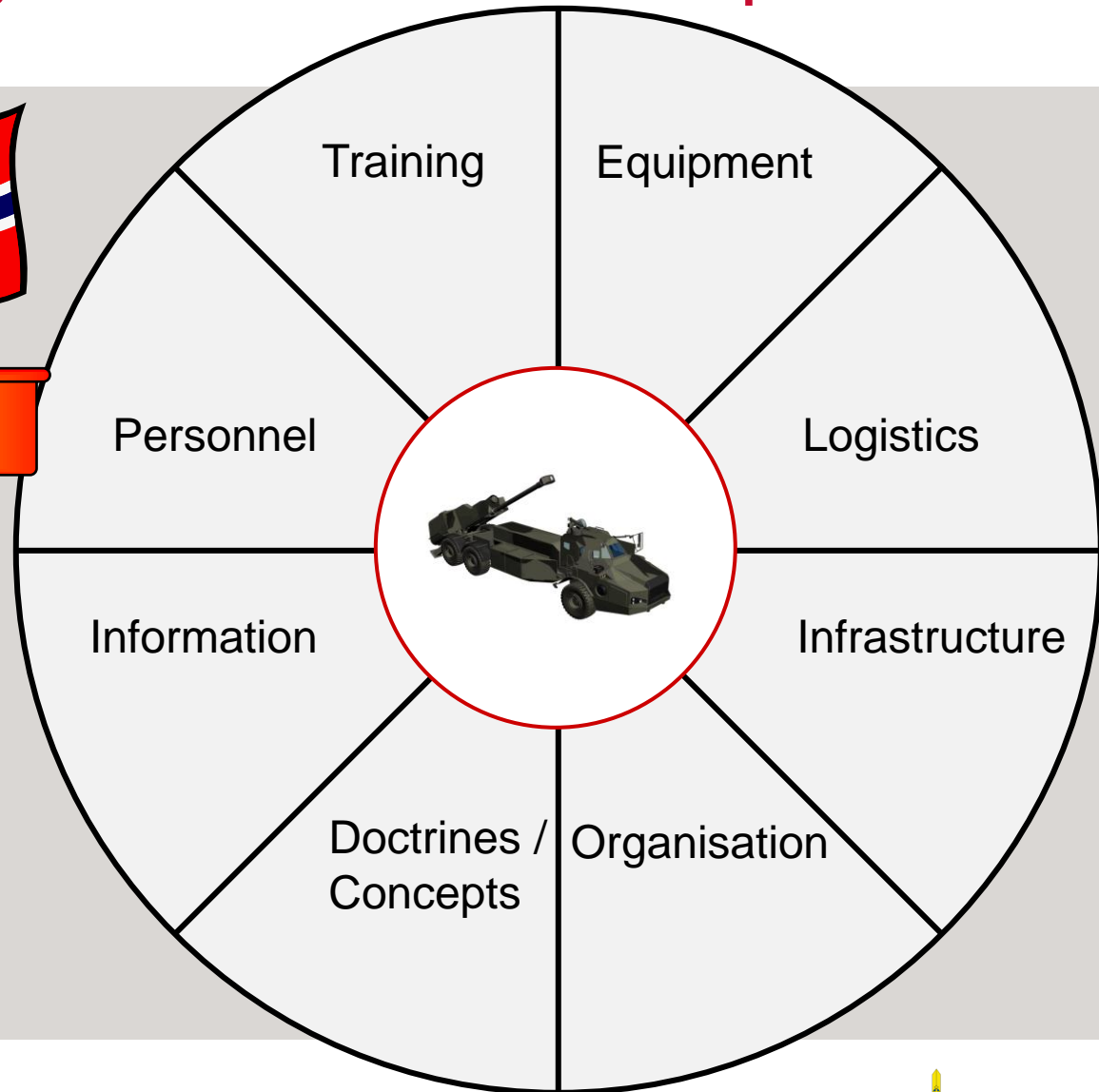

AMV XA-360



AWV – Armoured Wheeled Vehicle

- Background:
 - Decision 4th of February 2008 not to continue the development of SEP
- Still a need for armoured wheeled vehicles for 2 mechanized battalions
 - IOC 2014 with 113 vehicles (first battalion)

79 APC	7 Repair
16 C2	11 Ambulance
- Two RFQ processes:
 - RFQ 1 published 30th of October 2008
 - A formal complaint came from BAE
 - RFQ 2 published 30th of December 2009
 - A formal complaint came from GDLS
- The evaluations showed that the AMV from Patria was the best alternative
 - A contract was signed 13th of August 2010
- First deliveries in 2012 and full operating capability in 2014

THE COMPETITORS



Piranha III – GDLS



Boxer - ARTEC



AMV – Patria Vehicles



VBCI - Nexter



SEP – BAE Hägglunds



Alligator – BAE Hägglunds

Patgb 360

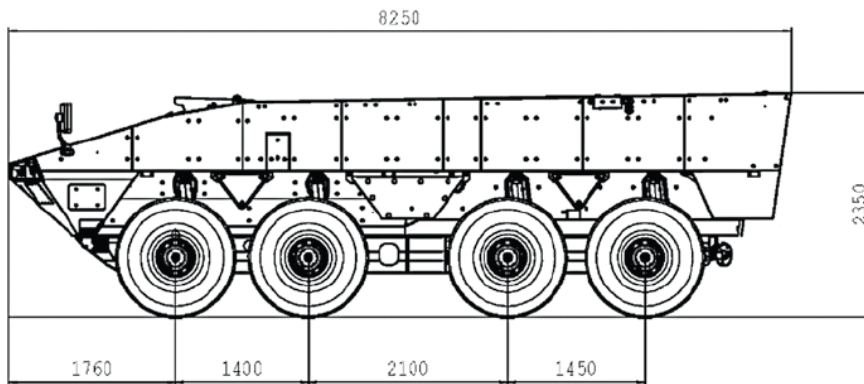

APC – Repair – C2 variants

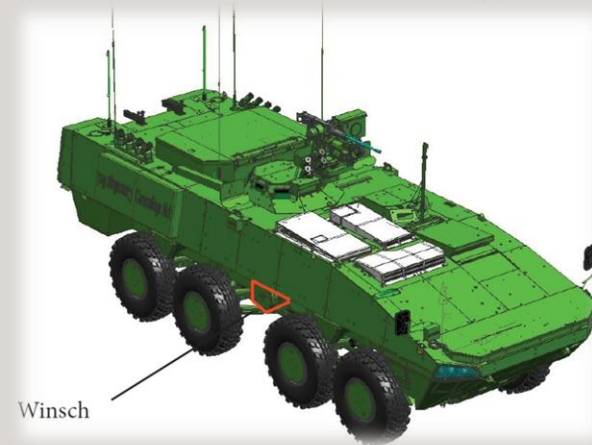
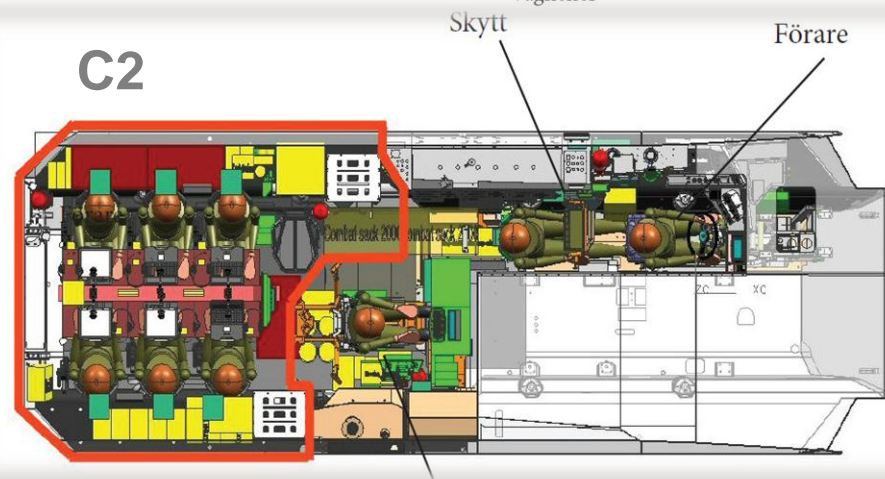
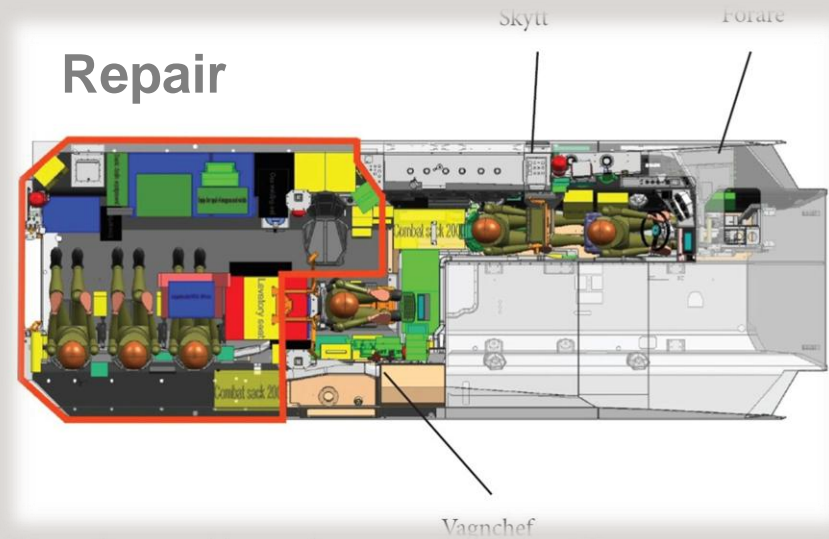
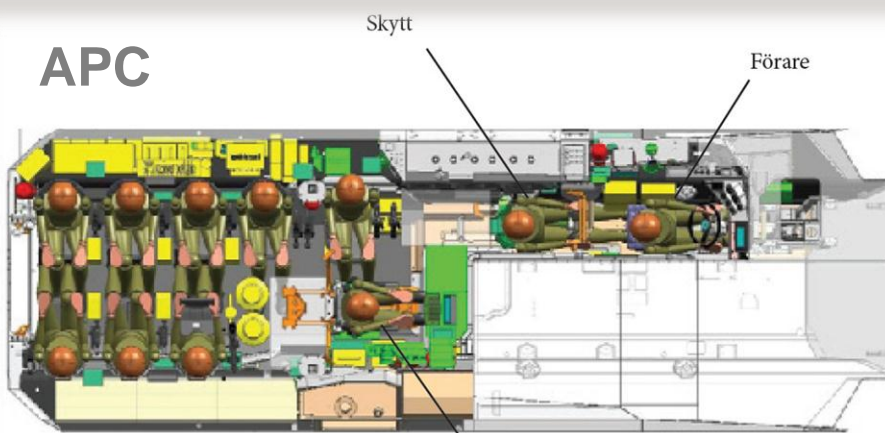

Crew

- Commander
- Driver
- Gunner

Operators

- APC = 8
- REP = 4
- C2 = 6

Ambulance variant

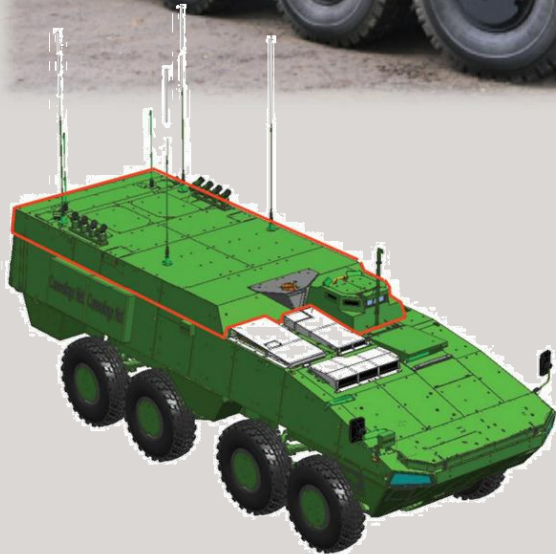
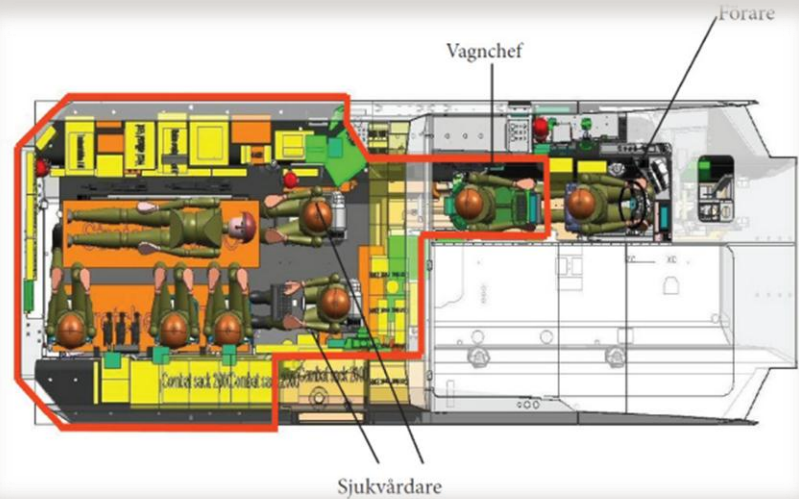

Crew

- Commander
- Driver

Operators

- 2 Medics

Casualties

- 3 + 1 on stretchers
- or 2 on stretchers

BvS10 MkII B



New Light Tracked Armoured Vehicle

- Need for a new light tracked articulated All Terrain Vehicle (ATV)
 - 15 vehicles for ISAF in January 2013
 - 33 vehicles with IOC mid 2014
 - options for another 127 vehicles
- Different role variants:
 - APC (also for ISAF)
 - Ambulance (also for ISAF)
 - Command & Control
 - Logistic (flatbed) with add-on module
 - Repair
 - Communication (Radio Link)
 - Engineer
 - Mortar
 - ARTHUR
- To replace Pbv 302 and MT-LB
- The procurement was done in a competition "off the shelf"
 - RFQ published in June 2011
 - Evaluation started October 2011
 - Award Decision early Jan 2012
- Tests part of the evaluation process
- Example of "shall requirements":
 - Oversnow capability
 - Capability to manoeuvre in mires
 - Air transportable in C-130
 - Amphibious capability
- Initial need of 15 ATVs for ISAF during 2012 solved with leasing
 - BvS10 Mk I front module (NL)
 - BvS10 "Viking" rear module (UK)



ISS-ATV-ISAF



Rear module



Front module

BvS10 Mk0 ATV-P (UK)

BvS10 Mk1 (NL)

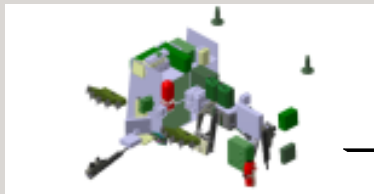

Parts from "UK UoR Kits"

- Bar-Armour
- Additional ballistic side protection
- Better mine protection



Parts from "NL UoR Kits"

- Bar-Armour
- Additional ballistic side protection
- Better mine protection
- Plat Ringmount
- Night camera

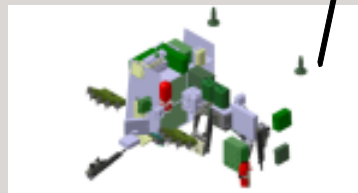

ISS-ATV-ISAF upgrading

- Command- and Communication system
- Additional mine protection front module
- Holers, fastenings, storage etc

ATV – The Competing Candidates

- Bids were received from BAE Systems Hägglunds (BvS10 MkIIB) and Singapore Technologies Kinetics (Bronco 2)
- Before the RFQ was published product demonstrations and tests were performed in Swedish winter environment (2010-2011) with both of the expected candidates



■ ATTV Bronco 2



■ BvS10 MkIIB

Product demonstrations



BvNy evaluation – Top level

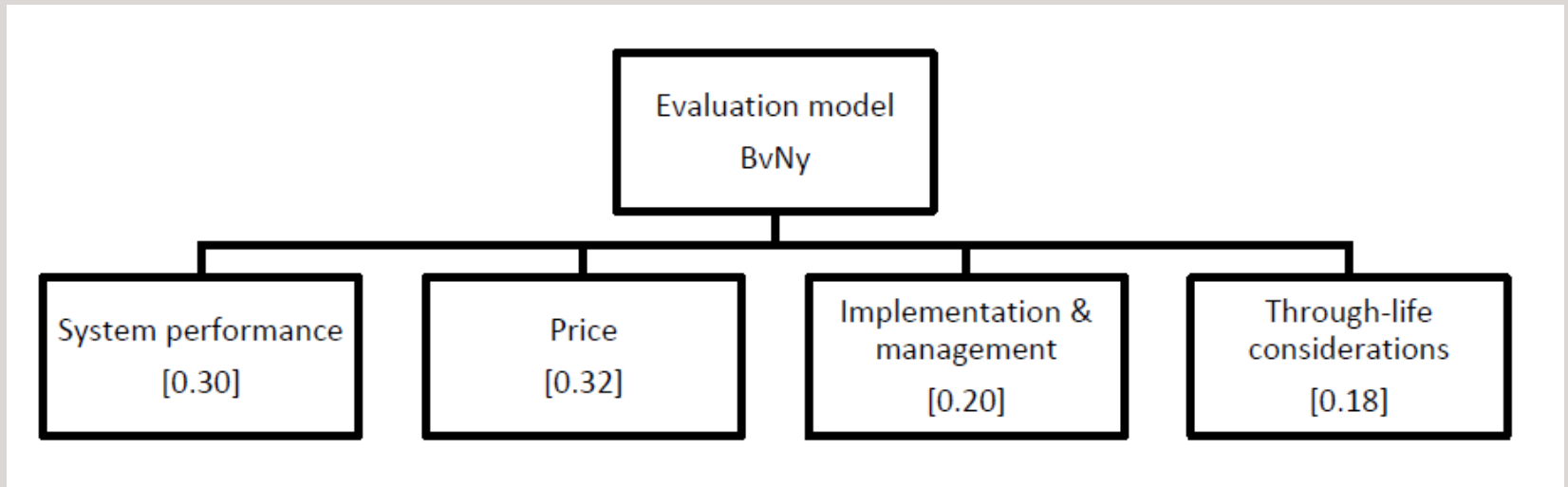

- All the "shall requirements" are mandatory and must be fulfilled
- The compliance to the "should requirement" is evaluated
- The idea in the RFQ is to be as transparent as possible
- This gives the opportunity for the Tenderer to balance their bid
- It would hopefully also prevent a complaint to a greater extent

System Performance

- The basis for evaluation of System Performance was the compliance statements to system performance requirements together with the descriptions of the offered system.
- Tenderers were made aware that high grades would be given for tenders where:
 - The “should” requirement is fulfilled without any restrictions.
 - There is no conflict with other requirements in the System Specification.
 - The technical solution is well described in the documentation, clearly showing how the requested function has been integrated in the design.
 - Test reports are included that give confidence that the stated “offered performance” will be fulfilled.
- Lower grades were given for compliance without description and partial compliance

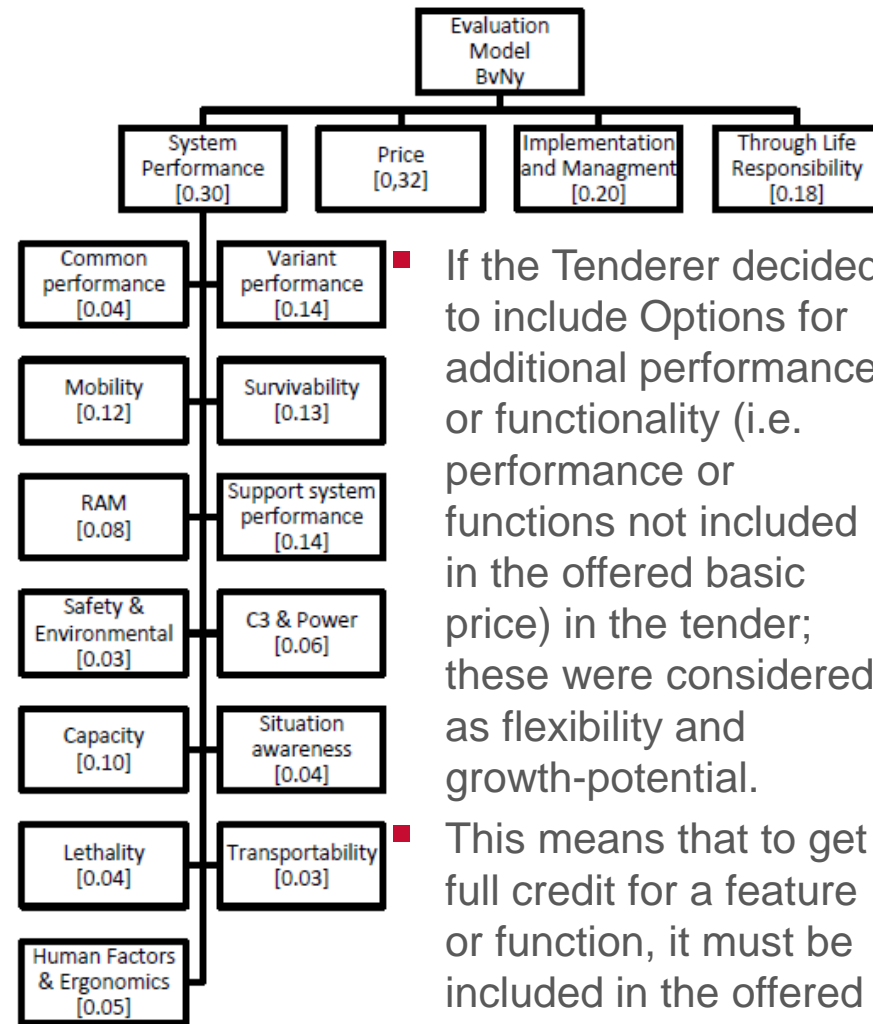

■ If the Tenderer decided to include Options for additional performance or functionality (i.e. performance or functions not included in the offered basic price) in the tender; these were considered as flexibility and growth-potential.

■ This means that to get full credit for a feature or function, it must be included in the offered basic price.

Price

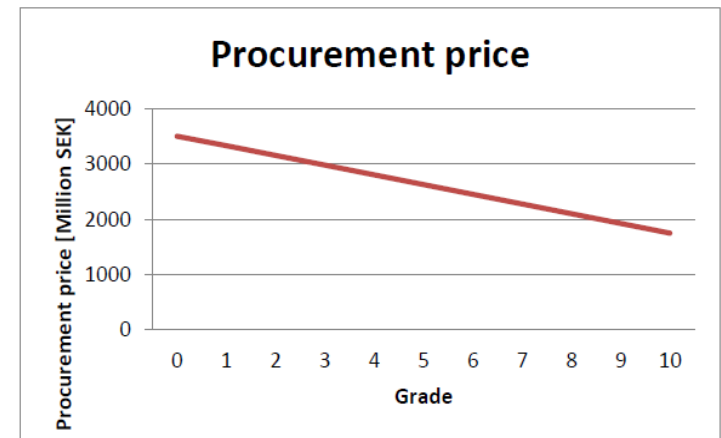
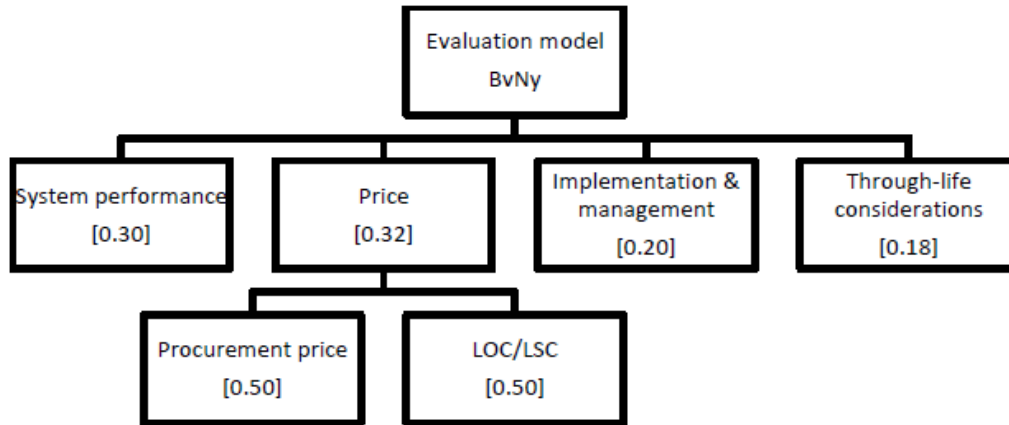

- Price given the highest weight in the evaluation model
- Extreme transparency gives the opportunity to know the exact “score”
- Each Tenderer is requested to give needed values for calculation

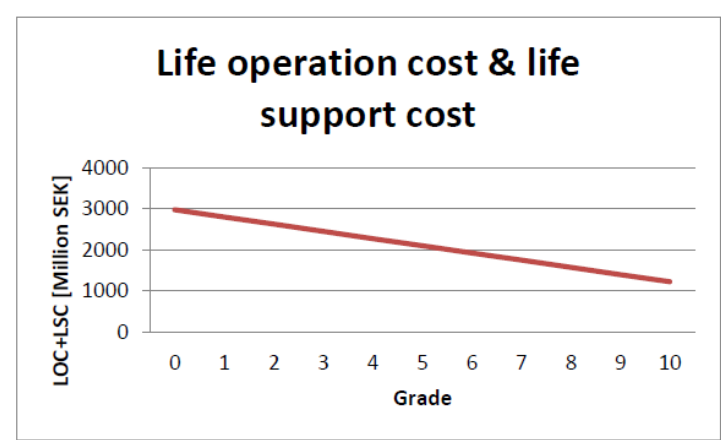

Implementation & Management

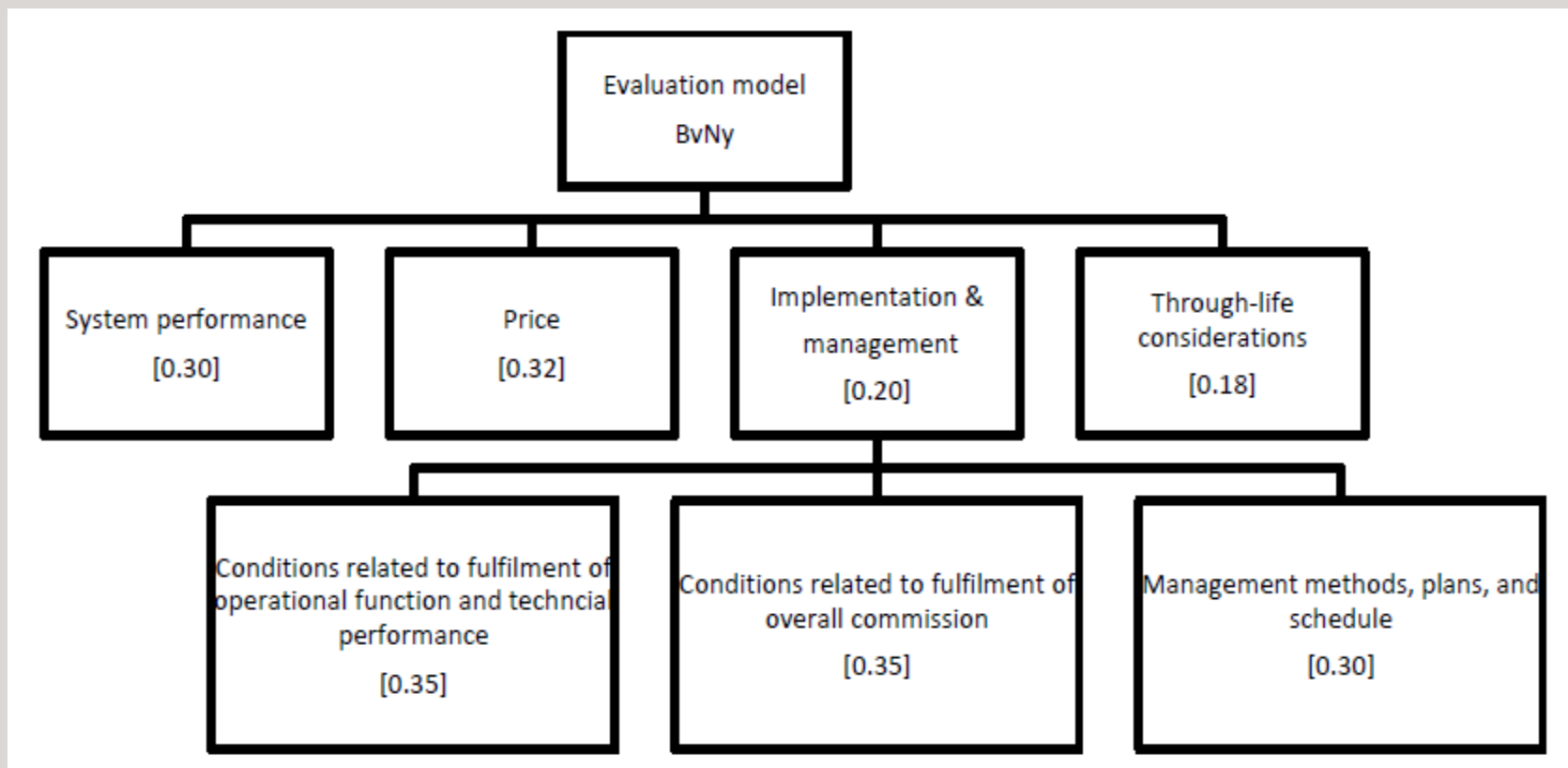

Through-life considerations

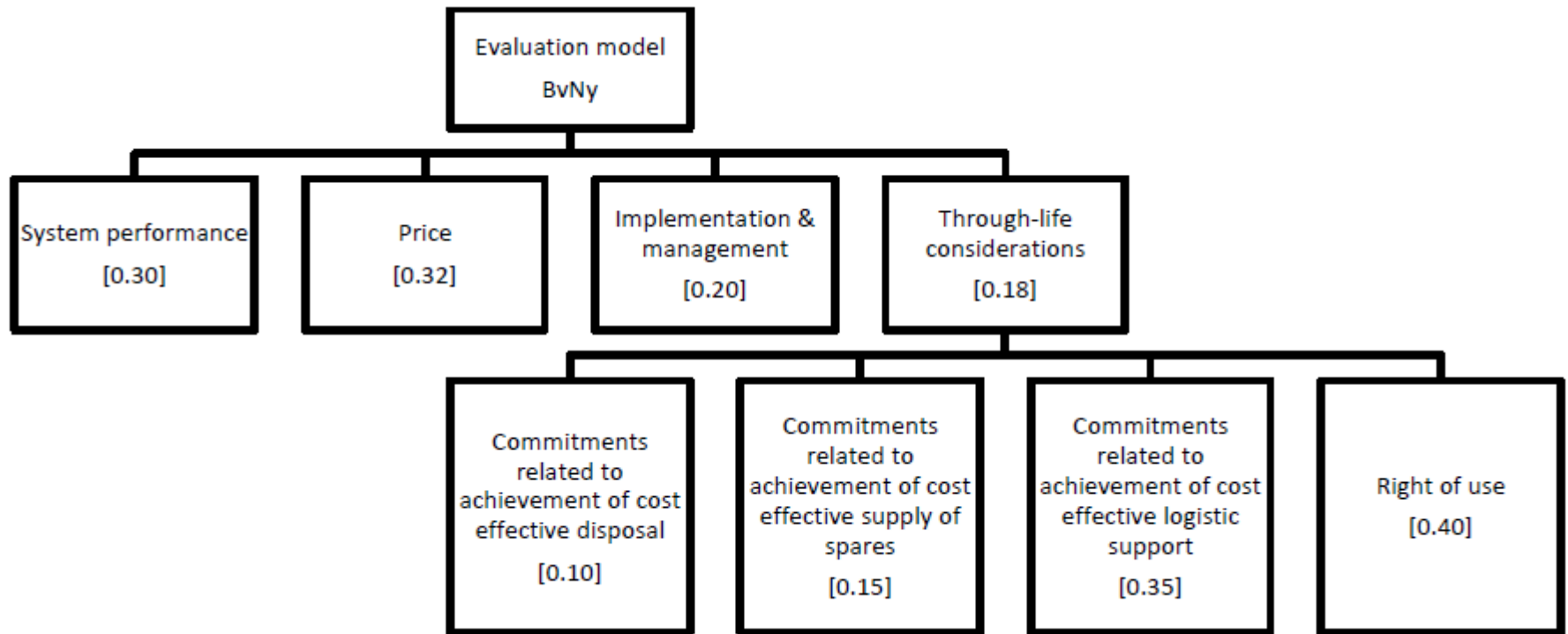

Scale for Grading

- 10 Exceptional
- 9 Excellent
- 8 Very good
- 7 Above standard
- 6 Good
- 5 Adequate
- 4 Acceptable
- 3 Weak
- 2 Marginal
- 1 Inadequate
- 0 Not compliant

Value	Rating	Criteria
10	Exceptional	<ul style="list-style-type: none"> Offered performance/conditions is significantly higher/better than the requirement(s) There is no perceived risk related to the stated compliance The offered solution can give synergy effects to the fulfillment of other requirements Described work method/process gives synergy effects to other parts of the work The plan/document is comprehensive, easy to understand, fully in line with other parts of the commitment and gives opportunity for significant risk reduction and/or cost reductions Description of offered solution is comprehensive, well described, credible and supported with high confidence evidence
9	Excellent	The offer does not fully meet the definitions for "Exceptional" but is better than "Very Good"
8	Very Good	<ul style="list-style-type: none"> Offered performance/conditions is higher/better than the requirement(s) There is very little perceived risk related to the stated compliance The solution supports fulfillment of other requirements Description of work method/process are comprehensive, well described, and fully in-line with guidelines/standards The plan/document is comprehensive, easy to understand, fully in line with other parts of the commitment and gives opportunity for risk reduction and/or cost reductions Description of offered solution is comprehensive, well described, credible and supported with evidence
7	Above Standard	The offer does not fully meet the definitions for "Very Good" but is better than "Good"
6	Good	<ul style="list-style-type: none"> Offered performance/conditions is in accordance with the requirement(s) There is little perceived risk related to the stated compliance There are no conflicts related to fulfillment of other requirements Description of work method/process is easy to understand and fully compliant with the guidelines/standards The plan/document is easy to understand and is fully in line with other parts of the commitment Description of offered solution gives a credible and clear picture of the solution
5	Adequate	The offer does not fully meet the definitions for "Good" but is better than "Acceptable". Deviations and conflicts are neglectable
4	Acceptable	<ul style="list-style-type: none"> Offered performance/conditions means acceptable deviations from the requirement(s) There is some perceived risk related to the stated compliance There are acceptable conflicts related to fulfillment of other requirements Description of work method/process is compliant with the guidelines with acceptable deviations The plan/document include limited conflicts with other parts of the commitment There is no information in the tender describing the fulfillment of the requirement
3	Weak	The offer does not fully meet the definitions for "Acceptable" but is better than "Marginal"
2	Marginal	<ul style="list-style-type: none"> Offered performance/conditions is partially in accordance with the requirement(s) There is significant doubt about the understanding or ability to meet the requirement There are conflicts related to fulfillment of other requirements Description of work method/process is partially compliant with the guidelines The plan/document include contradictions or conflicts with other parts of the commitment The information in the tender describing the fulfilment of the requirement is questionable
1	Inadequate	The offer does not fully meet the definitions for "Marginal" but is better than "Non-compliant"

Evaluation process

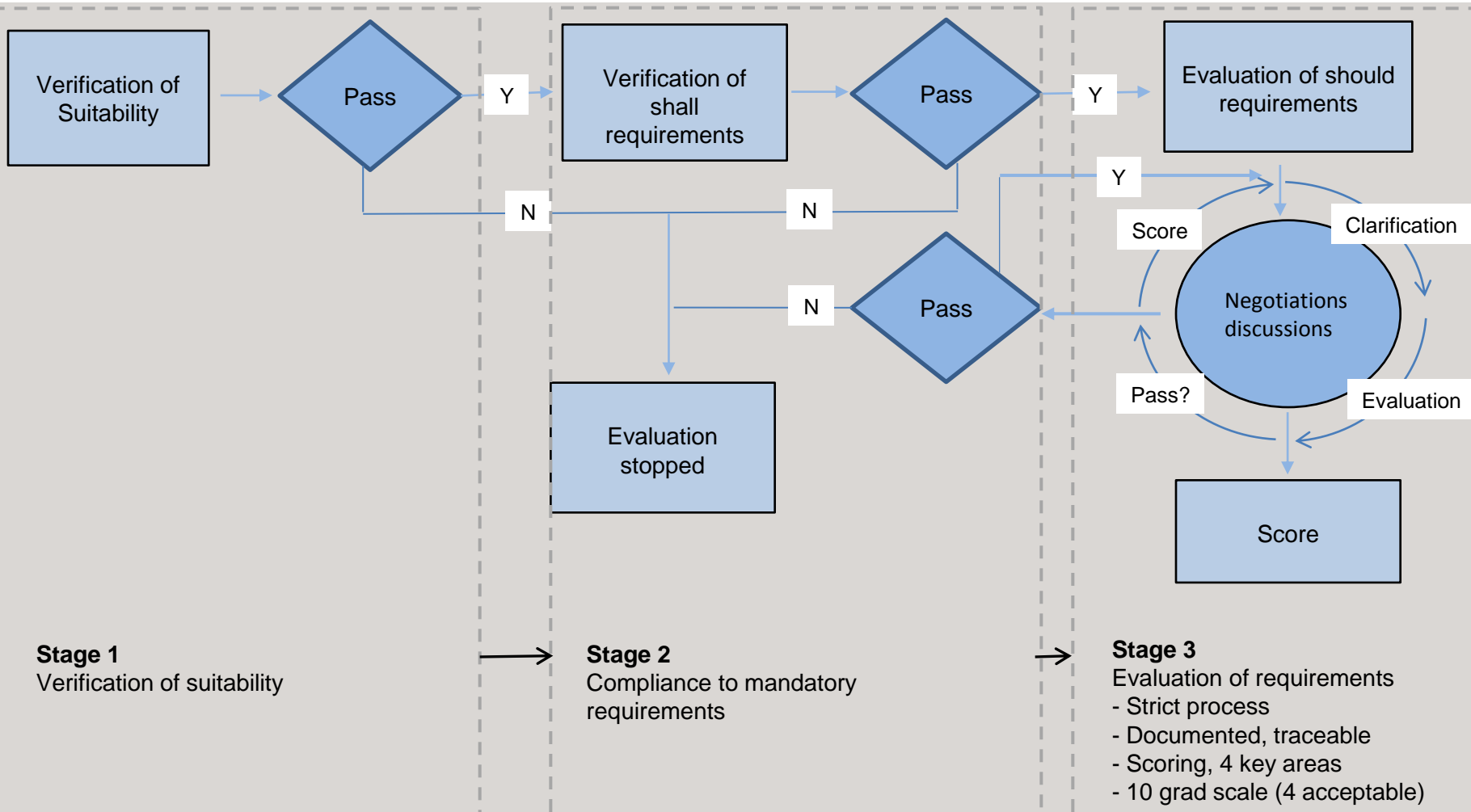

Evaluation process

- The tenders have been evaluated iteratively in order to:
 - Receive full understanding of the tender (enabling questions and answers)
 - Ensuring a correct evaluation (taking care of clarifications made by Tenderer)

Finally FMV (internal revision) has done a guarantee of quality on our assessment.

This to provide a high degree of confidence to the assessment.

FMV decision

- FMV decision is based on:
 - Fulfilment of all mandatory requirements
 - Consideration of firm commitments
 - Evaluation of the entire commitment
 - Clarifications and improvements
 - Score
 - Top level evaluation

- Test results have been used as supporting information

Tests

- Tests were performed as part of the procurement process.
- The test results have been considered as confidence and credibility to what is stated as commitments in the tenders.
- This means that the test results have not constituted a certain grade on their own but will be used as supporting information.
- The reason for this is that FMV does not know to what level the configuration of provided test vehicles will deviate from what is offered.
- Tests were performed with the Bv206S (Bv309B) as a reference vehicle.
- As stated in the System Specification the reference vehicle Bv309B was towing an empty trailer.
- Tests were performed for 3 weeks
 - Technical Performance
 - Amphibious capability & Mobility in mires
 - Stowing of equipment
 - Limited analysis of overhaul & repairability



Example of tests with BvS10 Mk II



Example of tests with Bronco 2



FMV Award Decision

- BAE Systems Hägglunds AB submitted the economically most advantageous tender
- The tenderer fulfilled all mandatory requirements
- The tenderer received the highest score after the evaluation, based on the requirements and the evaluation model stated in the Request for Quotation
- Award to BAE Hägglunds with BvS10 MkIIB



Photo shows the BvS10 Mk I test vehicle

Summary

- A new strategy for defence materiel acquisition
- Upgrading of existing materiel first hand choice
- Procurement in competition “off-the-shelf”
- Transparency to avoid processes in court
- Comparative tests and verifiable requirements
- Development only in rare cases
- International co-operation where possible
- Level playing field within EU

Questions...?

