

## **Structured Packings**

Energy-efficient, innovative and profitable

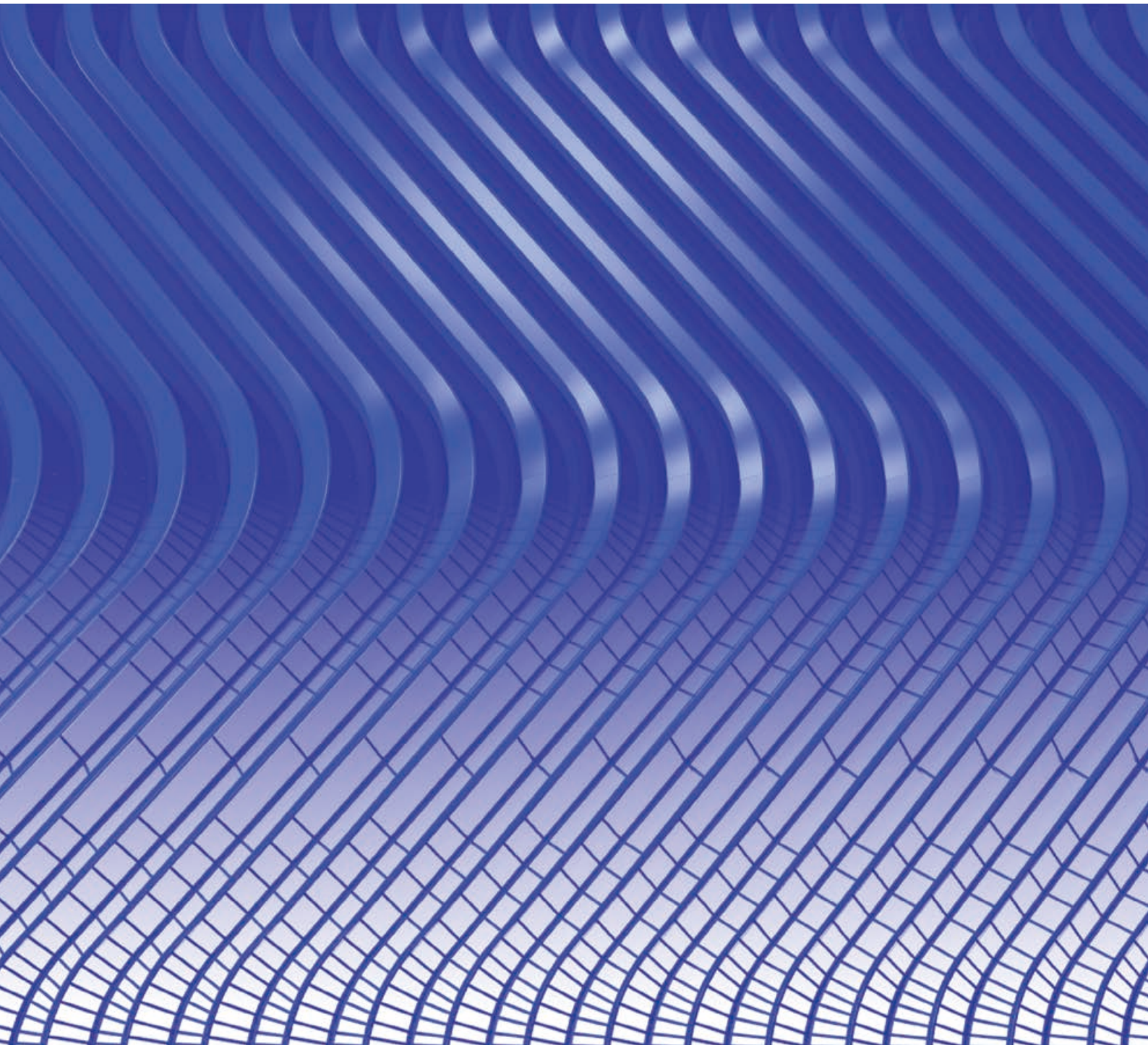

# Sulzer Chemtech – Mass Transfer Technology

Your Partner in Separation and Mixing Technology

## The Highest Level of Application Know-how

Our team provides state-of-the-art expert know-how for more than 500 applications in 100 processes, this enables us to optimize the performance and your installation.

## Fast and Reliable Turnaround Services

We don't shut-down, when you shut-down. You can rely on Sulzer professionals, expertise and procedures to get you back and running in the shortest possible time.

## Comprehensive Engineering and Technology Services

We provide a full scope of associated engineering and technology services to optimize or trouble-shoot your installation.

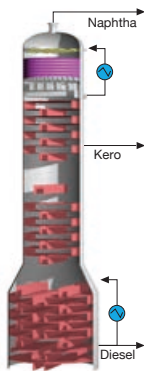

## A Broad Range of Innovative and High-performing Products

Our more than 200 products cover a wide range of needs in the field of separation and mixing technology.

They have proven their performance in more than 100,000 columns, 40,000 gas/liquid separators and 100,000 mixers in operation worldwide.



0602 2510

### MellapakPlus™ Packing

Often copied, never equaled

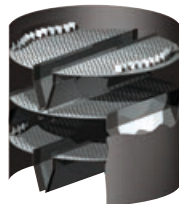

0605 2504

### VGPlus™ Trays

One of the best high performance trays ever tested at FRI



0603 2535-3

### NeXRing™

The next big thing in random packing



0694 2720

### SMV™ static mixer

High mixing efficiency combined with large turn-down processing capabilities



### Dusec Plus™ Coalescer

High performance with minimum pressure drop

<b>Metal Sheet Packings</b>	<b>4</b>
<b>Gauze Packings</b>	<b>8</b>
<b>Special Packing Types</b>	<b>11</b>
<b>Column Internals</b>	<b>16</b>
<b>Services</b>	<b>18</b>

## Sulzer Structured Packing Portfolio – The complete range

Structured packing is one of our core abilities. Over 50 years of experience in development, design, and fabrication of this type of packing makes us your best partner to find the optimum solution for your application. This brochure provides an overview of all Sulzer structured packing types and their applications.

Sulzer's complete structured packing portfolio ranges from the conventional BX gauze packing, developed by us 50 years ago, to the MellapakPlus high capacity packing. We offer packing types for all kind of applications, made in almost all types of metal and also other corrosion resistant materials.

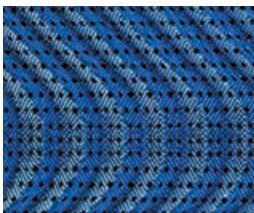

MellapakPlus™  
for improved  
capacity



Mellapak™  
the allrounder  
packing



BX™ and BXPlus™  
gauze packings  
for high separation  
efficiency

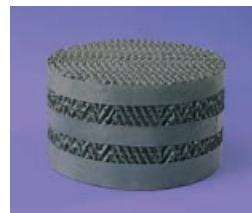

CY™ and CYPlus™  
gauze packings  
for even higher  
efficiency



AYPlus™ DC for  
aqueous solutions  
and low liquid loads

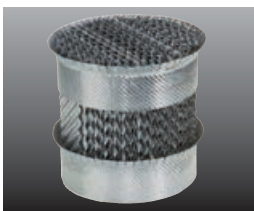

Mellacarbon™  
for demanding  
corrosive  
applications



Mellapak™ and  
MellapakPlus™ in  
plastic for corrosive  
applications



Mellagrid™, F-Grid™  
and Nutter Grid™ for  
fouling conditions

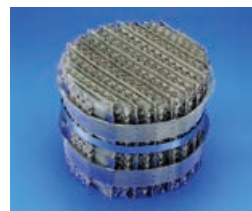

Katapak™-SP  
for reactive  
distillation



Laboratory  
Packings for  
small columns

# MellapakPlus

For improved capacity

MellapakPlus is a capacity enhanced structured packing.

It combines all advantages of the metal sheet packing Mellapak with new geometrical features.

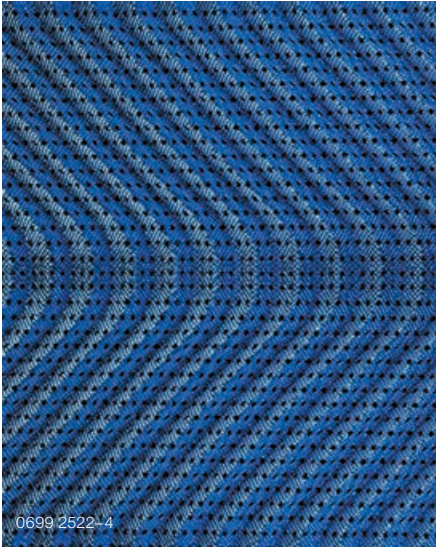

## Features of MellapakPlus

At the lower and upper end of each packing element, the orientation of the corrugation gradually approaches the vertical axis. Advantages of this geometrical modification:

- The vapor flow smoothly changes direction at the interface between two packing elements
- At the interface vapor flow is nearly parallel to the vertical axis of the column. The gas velocity is therefore reduced by about 25% compared to the velocity inside the packing element

Both factors reduce the pressure drop and the shear forces, which are especially critical at the inter-face due to the presence of thicker and less stable liquid films. As a result, premature flooding at the interface is no longer of concern.

In the interior part of the packing element the geometrical features of MellapakPlus and Mellapak are identical. Hence, separation efficiency is similar – but with a significant increase in capacity and a reduction in pressure drop.

All other MellapakPlus properties – including installation procedure, mechanical strength and corrosion resistance – are identical to Mellapak.

MellapakPlus performance has been confirmed in category 1 tests at F.R.I.

## Internals

The close resemblance between MellapakPlus and Mellapak guarantees continued use of the whole range of well known and reliable internals. Internals are now able to handle the increased gas load typical for the high capacity of MellapakPlus. Sulzer Chemtech is committed to the ongoing, focused development of novel designs.

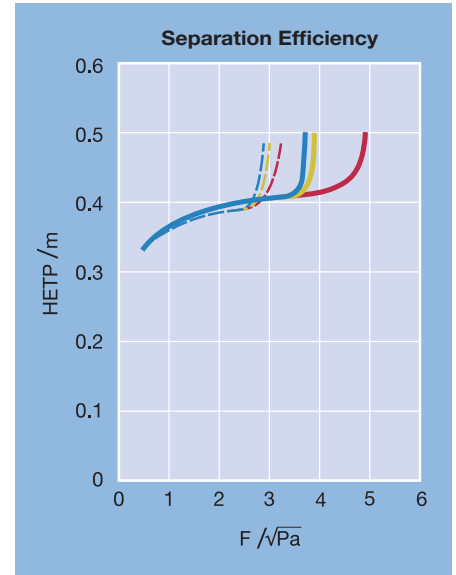

MellapakPlus 252.Y	Mellapak 250.Y
960 ———	960 - - - -
400 ———	400 - - - -
100 ———	100 - - - -
parameter = head pressure p /mbar	

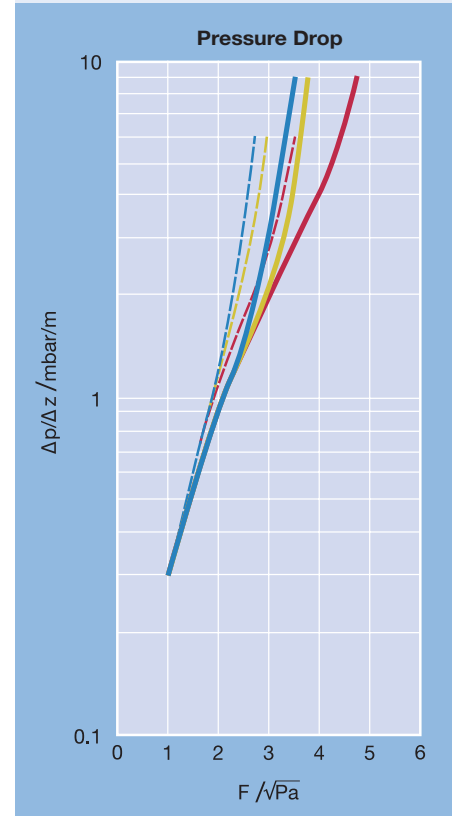

MellapakPlus 252.Y vs. Mellapak 250.Y

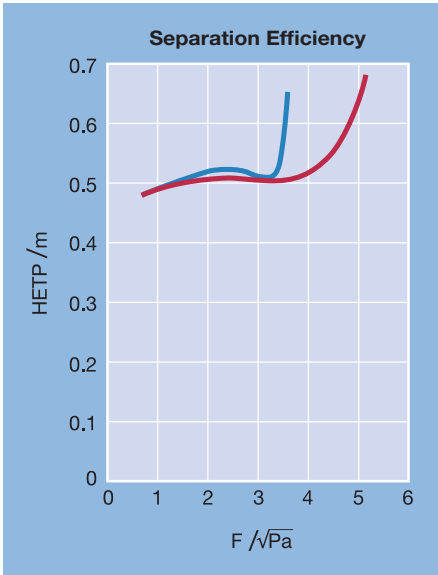

MellapakPlus 202.Y  
 960 ———  
 100 ———  
 parameter = head pressure  $p$  /mbar

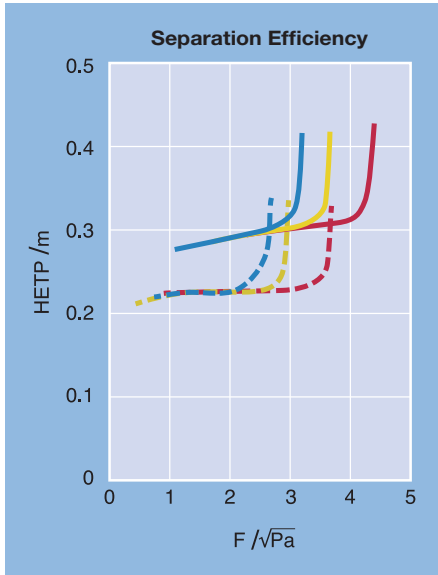

MellapakPlus 352.Y MellapakPlus 602.Y  
 960 ——— 960 - - -  
 400 ——— 400 - - -  
 100 ——— 100 - - -  
 parameter = head pressure  $p$  /mbar

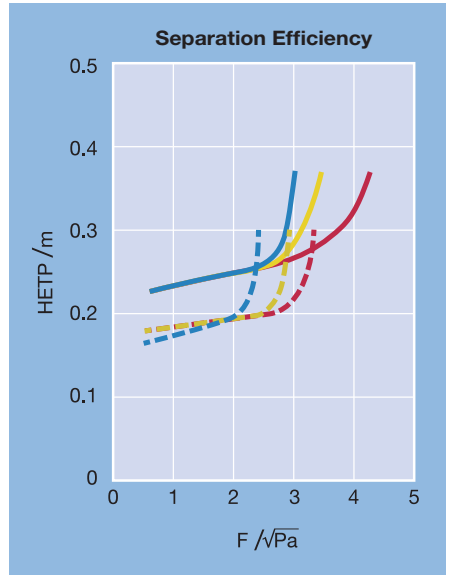

MellapakPlus 452.Y MellapakPlus 752.Y  
 960 ——— 960 - - -  
 400 ——— 400 - - -  
 100 ——— 100 - - -  
 parameter = head pressure  $p$  /mbar

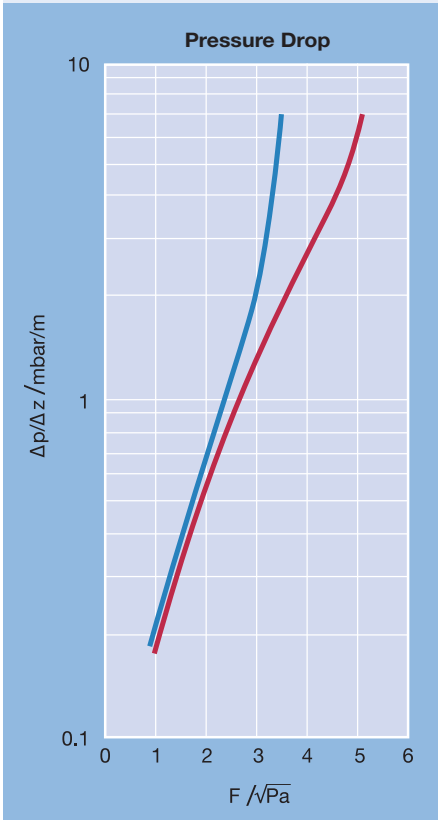

MellapakPlus 202.Y

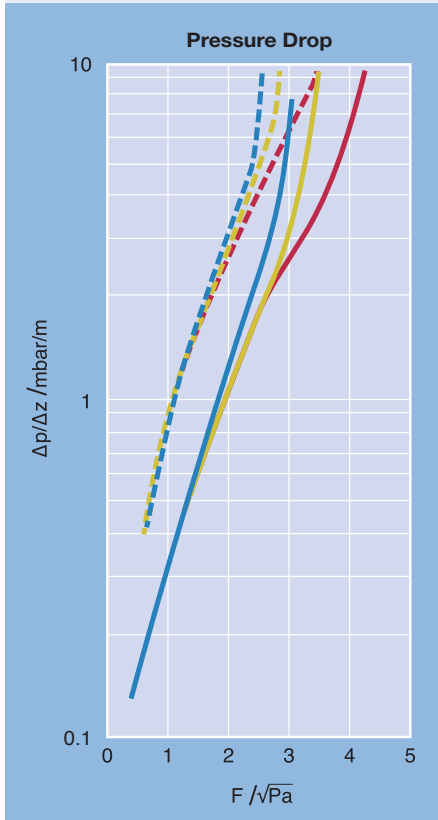

MellapakPlus 352.Y  
 MellapakPlus 602.Y

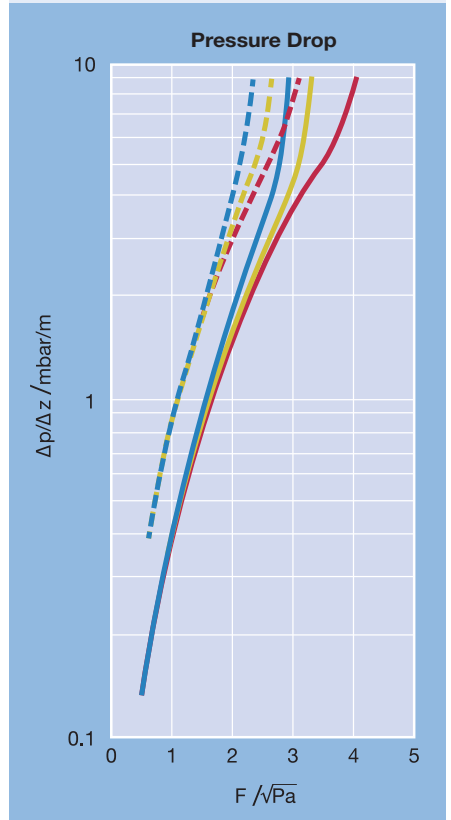

MellapakPlus 452.Y  
 MellapakPlus 752.Y

# Mellapak

The allrounder packing



0602 2510

Mellapak is the most widely used structured packing worldwide. It has proven excellent performance in columns with diameters up to 15 m. It is supplied in sheet metal thicknesses from 0.1 mm up.

## Special features

- Pressure drop per theoretical stage 0.3-1.0 mbar
- Pressure drop at 70-80% flooding about 2 mbar/m
- Minimum liquid load approx. 0.2 m<sup>3</sup>/m<sup>2</sup>h
- Maximum liquid load up to more than 200 m<sup>3</sup>/m<sup>2</sup>h (typically in desorption columns)

## Preferred applications

- Vacuum to moderate pressure
- High pressure in selected applications
- Increasing capacity of existing tray and packed columns

## Typical applications

**Chemical industry:** Ethylbenzene/styrene, tall oil, cyclohexanone/-ol, air separation

**Petrochemical industry:** Quench columns, C3- and C4- splitters, xylene splitters

**Refineries:** Vacuum and atmospheric columns

**Absorption:** Natural gas drying, CO<sub>2</sub>- and H<sub>2</sub>S-absorbers and strippers, ethyleneoxide absorbers and strippers, acrylonitrile absorbers

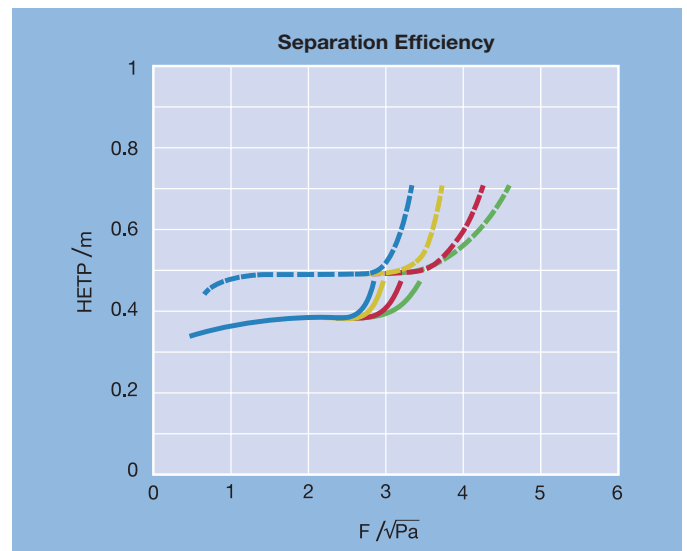

Mellapak 250.Y	Mellapak 250.X
960 ————	960 - - - -
400 ————	400 - - - -
100 ————	100 - - - -
50 ————	50 - - - -
parameter = head pressure p / mbar	

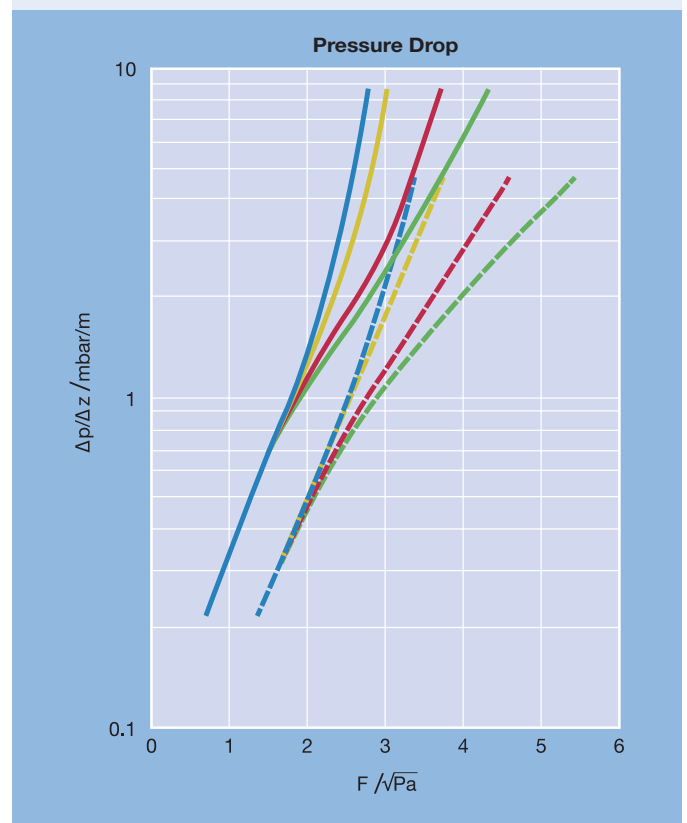

Mellapak 250.Y  
Mellapak 250.X

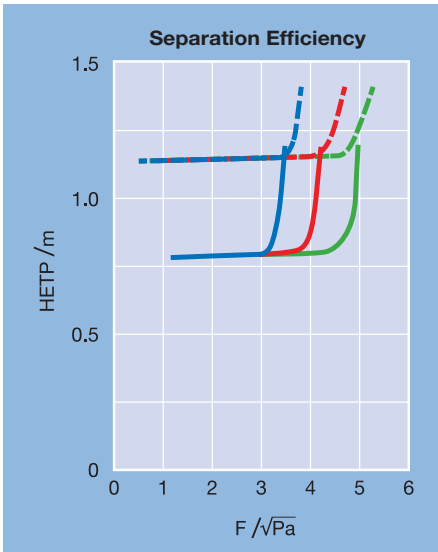

Mellapak 125.Y Mellapak 125.X  
 960 ——— 960 - - - -  
 100 ——— 100 - - - -  
 50 ——— 50 - - - -  
 parameter = head pressure p / mbar

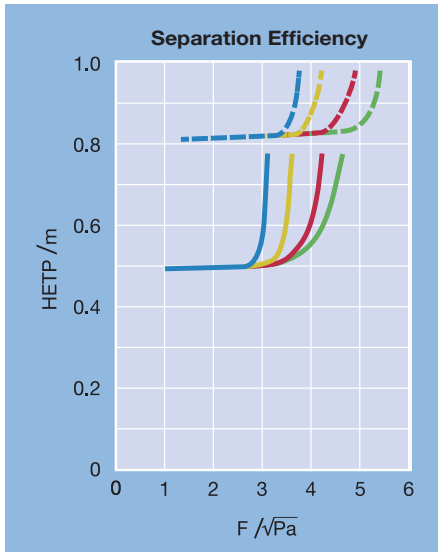

Mellapak 170.Y Mellapak 170.X  
 960 ——— 960 - - - -  
 400 ——— 400 - - - -  
 100 ——— 100 - - - -  
 50 ——— 50 - - - -  
 parameter = head pressure p / mbar

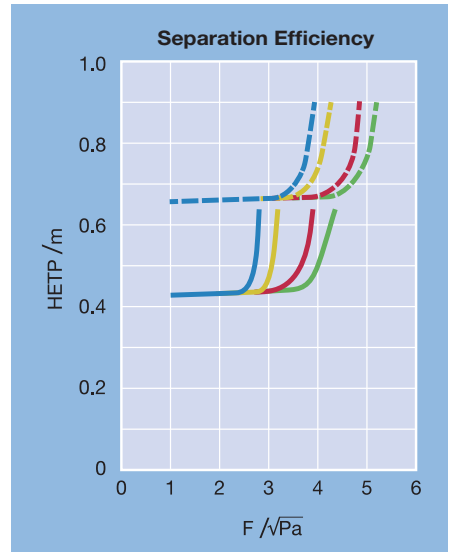

Mellapak 2Y Mellapak 2X  
 960 ——— 960 - - - -  
 400 ——— 400 - - - -  
 100 ——— 100 - - - -  
 50 ——— 50 - - - -  
 parameter = head pressure p / mbar

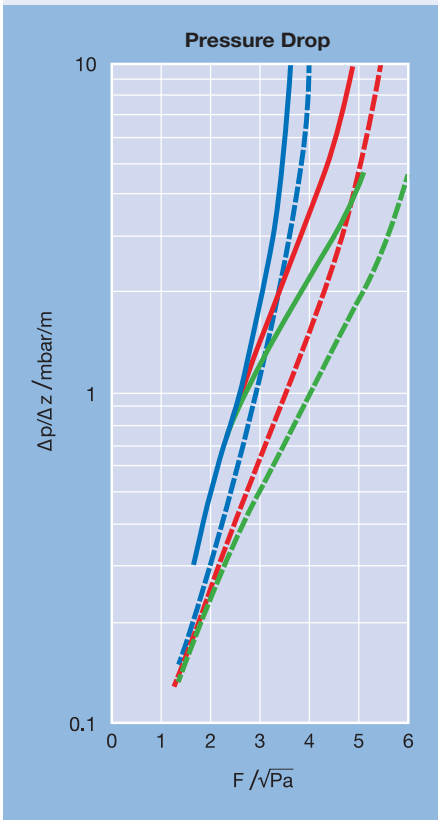

Mellapak 125.Y  
 Mellapak 125.X

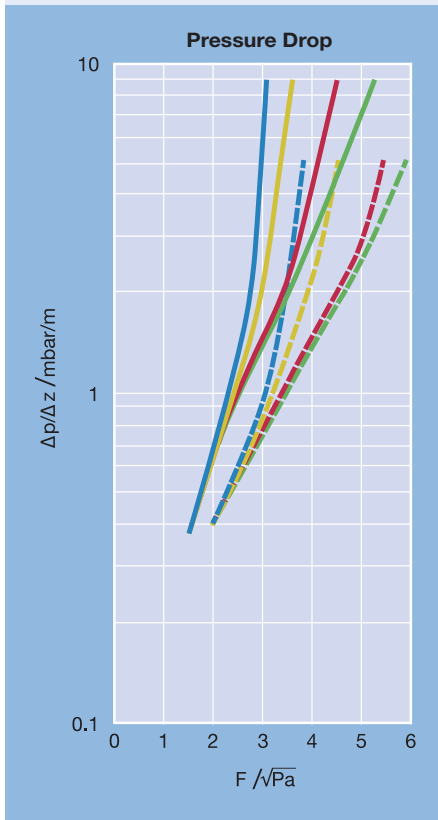

Mellapak 170.Y  
 Mellapak 170.X

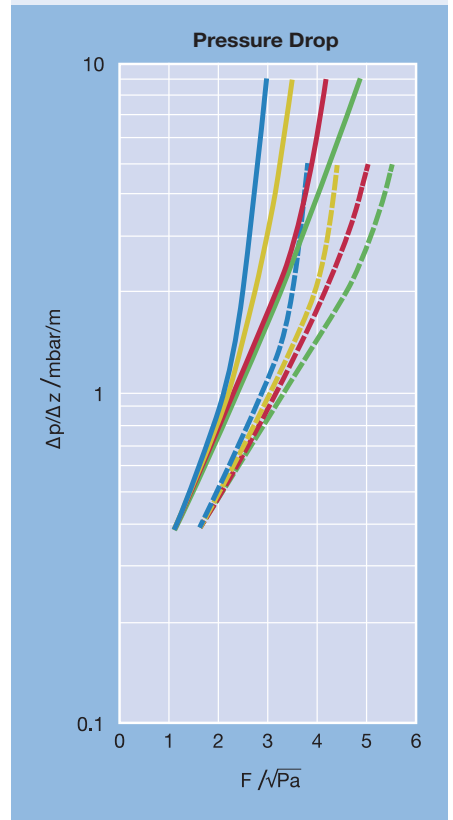

Mellapak 2Y  
 Mellapak 2X

# BX and BXPlus Gauze Packings

For high separation efficiency



0682 2017

This packing has been successfully employed in the industry for over 40 years. Largest diameter supplied to date: 6 m.

## Special features

- High number of theoretical stages per unit height
- Pressure drop per theoretical stage 0.1–0.5 mbar
- Most economical load range: F factor 1-2.5  $\sqrt{Pa}$
- Minimum liquid load approx. 0.05 m<sup>3</sup>/m<sup>2</sup>h
- Small hold-up

## Preferred applications

- Large number of theoretical stages
- Vacuum from 1 mbar to atmospheric pressure
- Where minimum pressure drop per theoretical stage is important

## Product applications

- Monomers from plastics (MDI, DMT, etc.)
- Fatty acids, fatty alcohols, fatty acid esters
- Mono-, di-, tri-, and tetraethylene glycols
- Fine chemicals

## BXPlus

BXPlus is a further development of the well proven gauze packing BX. Its geometry is similar to MellapakPlus. BXPlus offers the same efficiency as BX with a 20% lower pressure drop. It is recommended for gentle distillation at higher capacity.

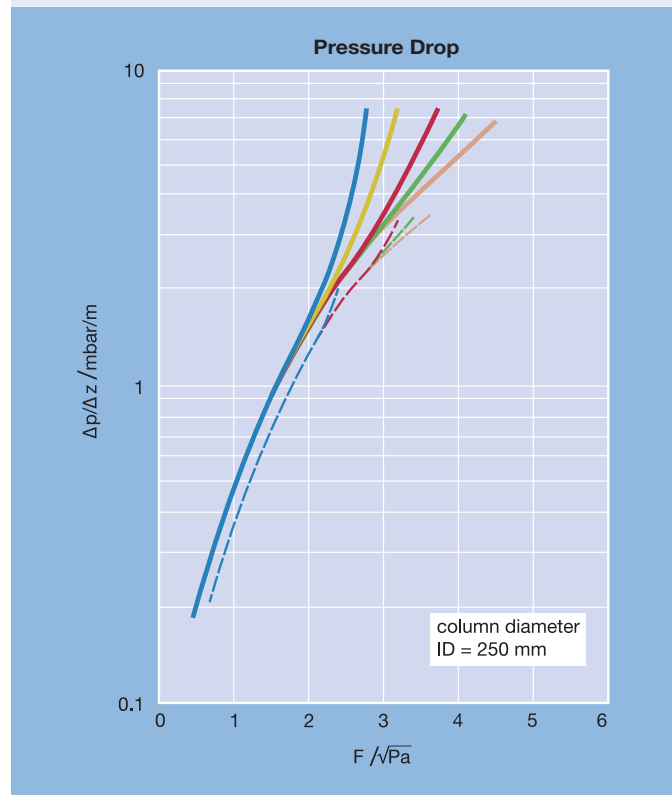
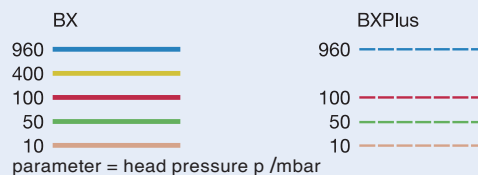
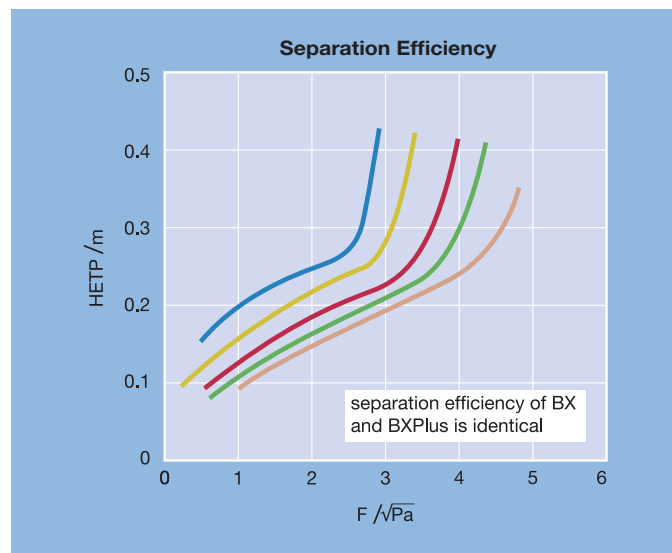

Gauze packing BX  
Gauze packing BXPlus



# CY and CYPlus Gauze Packings

For even higher separation efficiency



4588 3043

This packing was developed for separations that require a large number of theoretical stages. Largest diameter supplied to date: 1.8 m.

## Special features

- Maximum number of theoretical stages per meter
- Most economical load range: F factor  $1.5 - 2 \sqrt{Pa}$
- Minimum liquid load approx.  $0.05 \text{ m}^3/\text{m}^2\text{h}$
- Small hold-up

## Preferred applications

- For a very large number of theoretical stages
- Vacuum from 1 mbar to atmospheric pressure
- Small overall height
- Batch and continuous columns
- Pilot and laboratory columns (reliable scale up)

Limited suitability for:

- Fouling substances
- Non-wetting liquids

## Product applications

- Pharmaceutical products (vitamins, etc.)
- Fragrances (menthol, geraniol, etc.)
- Separation of isomers

## CYPlus

The traditional CY structure was modified using the know-how from the MellapakPlus and BXPlus concept for more capacity, resulting in the new CYPlus packing. The Plus structure allows for 15% more capacity while keeping the same efficiency as the traditional CY gauze packing.

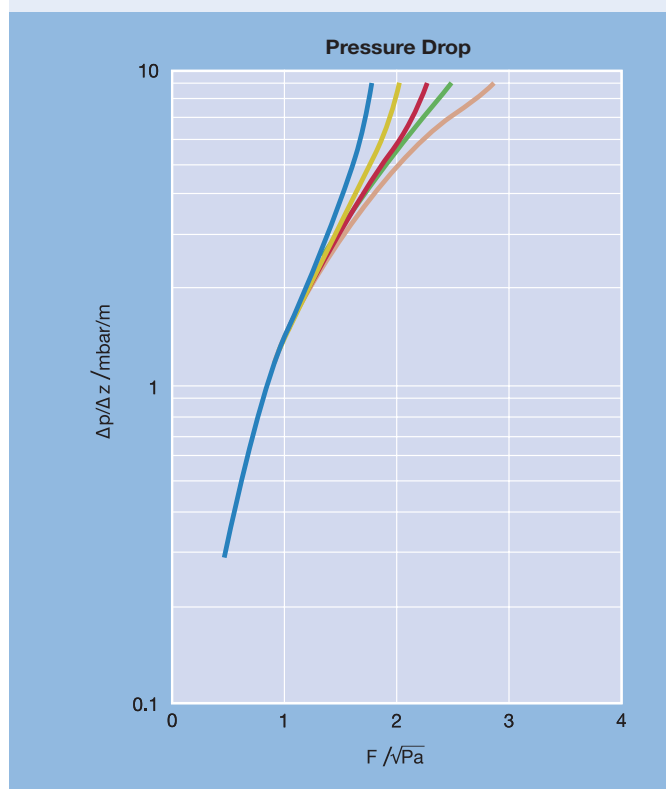
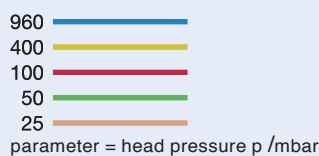
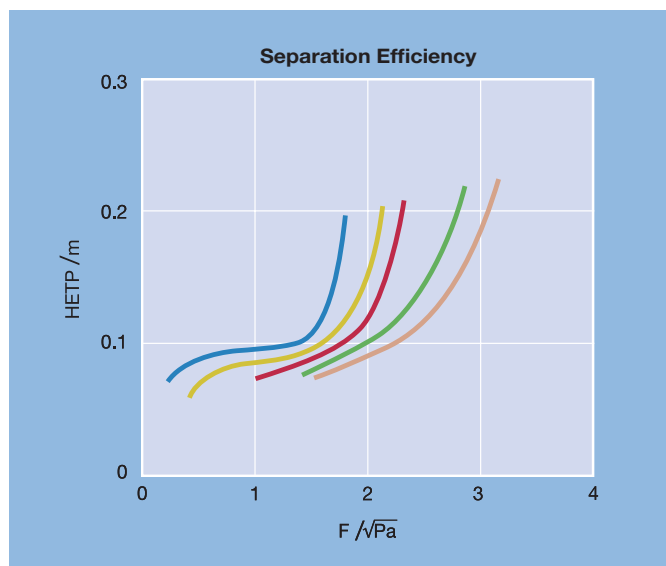

Gauze packing CY

# AYPlus DC

For aqueous solutions and low liquid loads

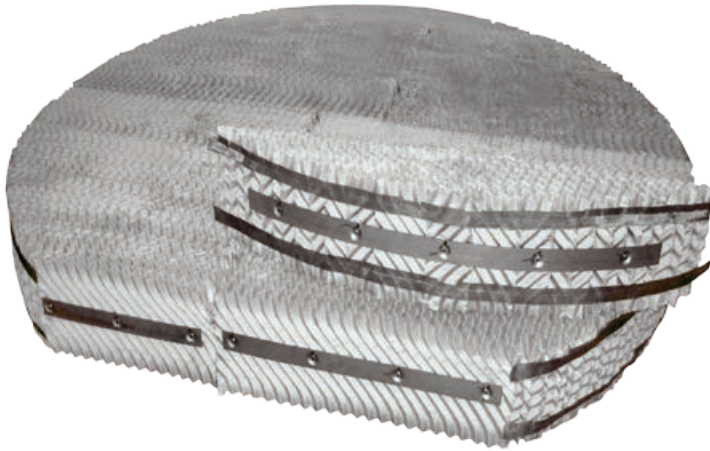

AYPlus DC is based on a newly developed hybrid gauze material combination and the geometry of MellapakPlus 252.Y. AYPlus DC has a distinctly increased separation efficiency compared to MellapakPlus 252.Y, in particular at low liquid loads and with aqueous systems.

## Special features

- Excellent wettability for organic and aqueous systems even at very low liquid loads such as below 0.1 m<sup>3</sup>/(m<sup>2</sup>h)
- Low HETP, depending on the system
- More than twice as efficient as comparable sheet metal or plastic packings in aqueous applications with low liquid load
- Pressure drop comparable to MellapakPlus 252.Y and for aqueous systems even lower
- Most economical liquid load range < 1 m<sup>3</sup>/(m<sup>2</sup>h)
- Maximum operating temperature about 300°C

## Product applications

### Aqueous systems

- Dimethyl acetamide/ water
- Dimethyl formamide/ water
- Gas sweetening wash sections
- Glycol dehydrations
- High-boiling alcohols/ water
- Wash sections in CO<sub>2</sub> absorbers

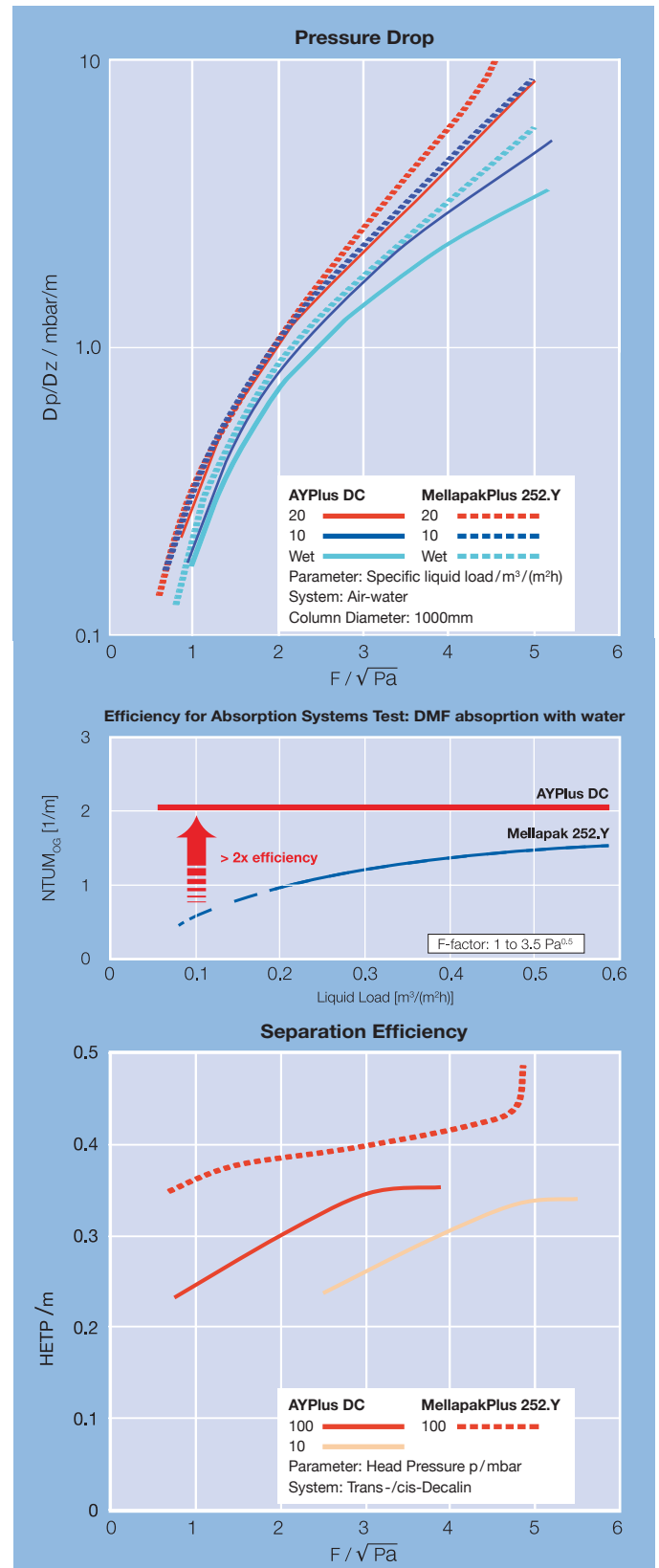

# Mellacarbon

For demanding corrosive applications



0697 2522

Carbon does not react with most solvents, acids or lyes. Sulzer Chemtech offers various Mellacarbon types.

- Corrosion-proof against caustic solutions, non-oxidizing inorganic acids including hydrofluoric acid and carboxylic acids
- Excellent wettability, also in aqueous systems
- Specific surface area of 125–1700 m<sup>2</sup>/m<sup>3</sup>
- High thermal stability (> 400°C)

## Product applications

- HCl separation for production and for HCl recovery (typically in the production of polycarbonate)
- MCA/DCA distillation
- Production of phosphoric acid
- Concentration of hydrofluoric acid
- Separation of chlorophenols

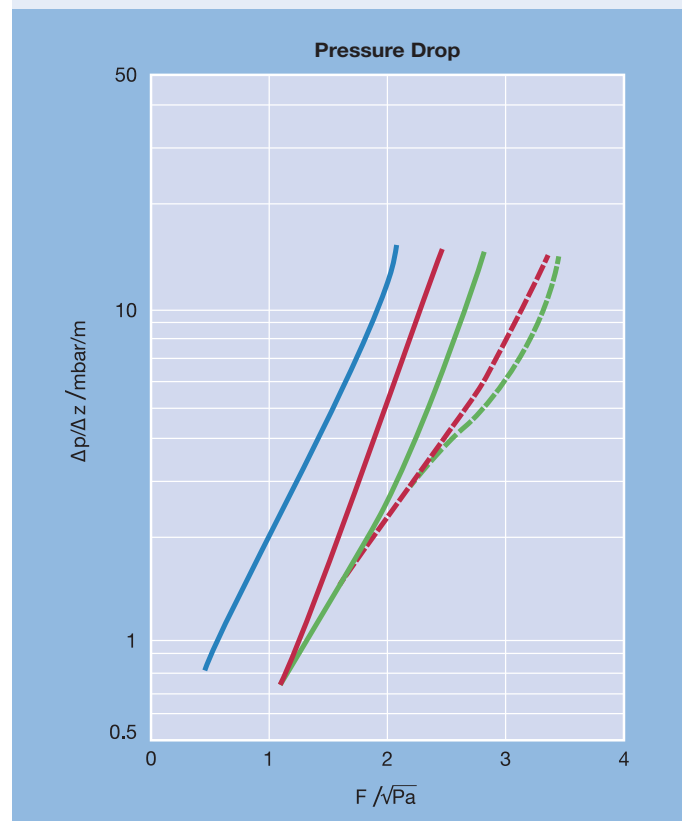
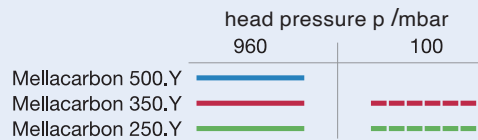
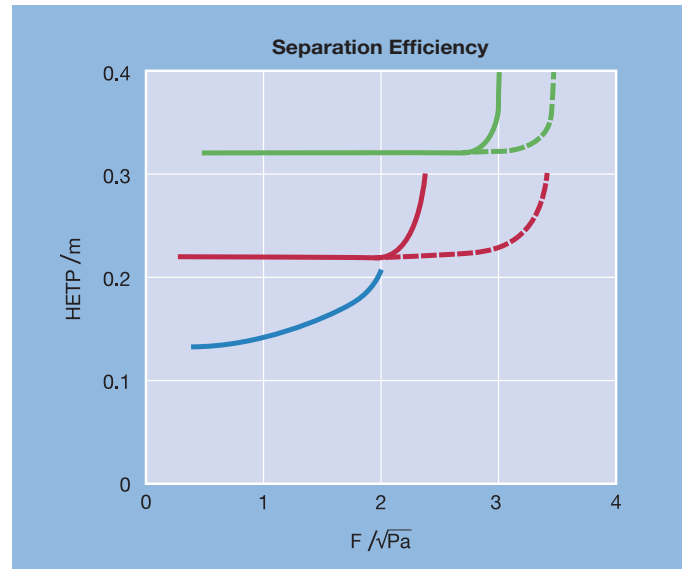

Mellacarbon

# Mellapak and MellapakPlus from plastics

For corrosive applications



0682 2021

The MELLAPAK 125.X, 125.Y, 250.X and 250.Y and MellapakPlus 252.Y are also available in different kinds of thermoplastics.

Packings made of polypropylene (PP), postchlorated polyvinylchloride (PVC-C), polyvinylidene-difluoride (PVDF), Teflon® PFA and polyether ether ketone (PEEK) can be supplied.

The plastic versions of MELLAPAK have proven operational record in various types of absorption and desorption columns.

## Special features

- Large number of transfer units per meter, low HTU, depending on the system
- Small pressure drop per meter packed height
- Most economical load range up to F factor  $4 \sqrt{\text{Pa}}$
- Maximum operating temperatures:  
approx. 110°C for polypropylene  
approx. 150°C for PVDF

## Product applications

- HCl absorbers
- SO<sub>2</sub> absorbers
- Flue gas cleaning columns
- Sea water deaerators

MellapakPlus 252.Y has the same efficiency as Mellapak 250.Y and same capacity as Mellapak 250.X

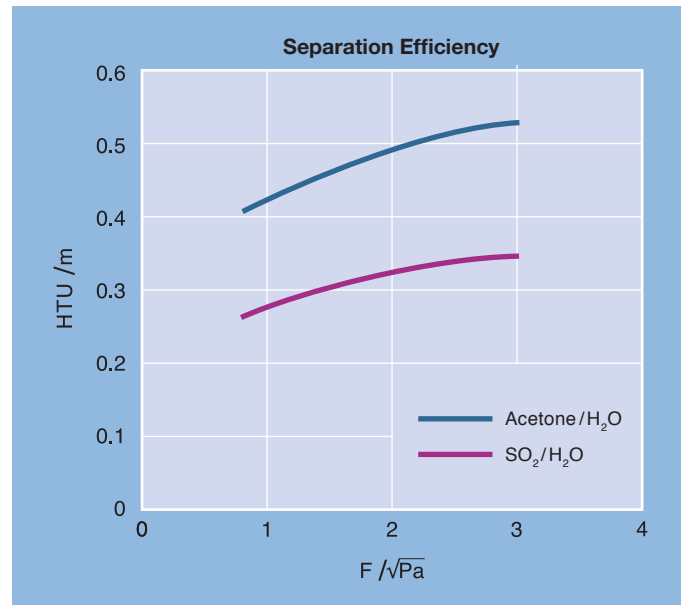

Separation efficiency of Mellapak 250.Y PP

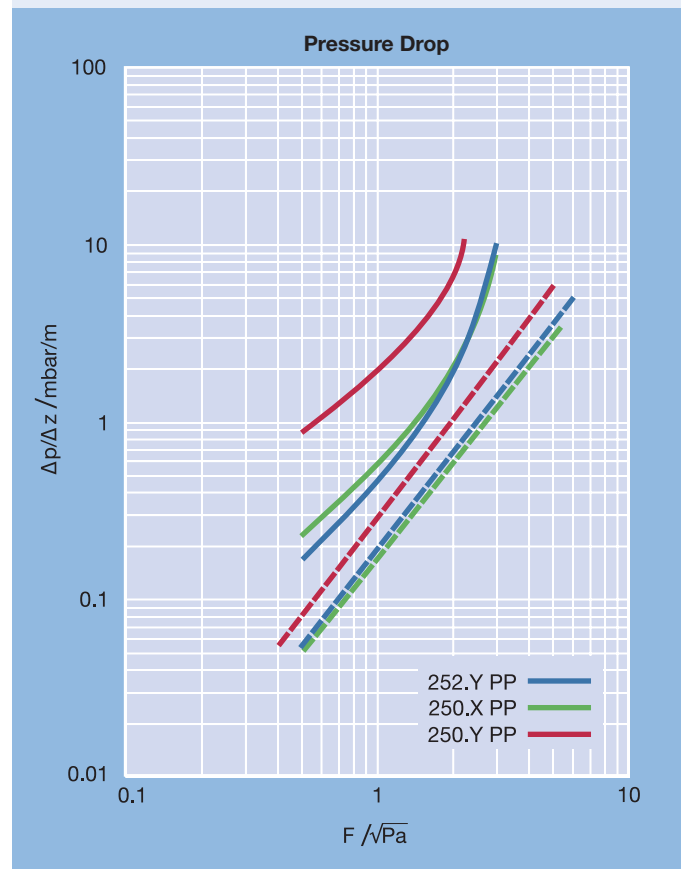

Mellapak PP atmospheric pressure

# Mellagrid, Nutter Grid and F-Grid

## For fouling conditions

Grids are developed for severe services that are susceptible to fouling, erosion, coking, and high solids content. Grids are installed in rigid modules stacked in successive layers with a fixed orientation, thus minimizing the overall pressure drop while simultaneously increasing tower efficiency.

We offer three types of grids: **Mellagrid**, **Nutter Grid** and **F-Grid**.

### Special features

- Not sensitive to coking and fouling due to its smooth surface and geometrical structure
- Efficient dissipation of temperature
- Better de-entrainment and separation efficiency than a traditional grid
- The low element height and its structure allow for easy cleaning. It can be removed, unscrewed and cleaned with a water jet
- Mechanically robust structure

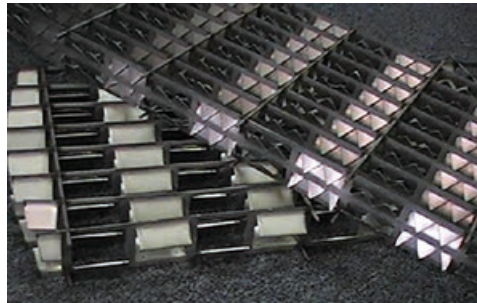
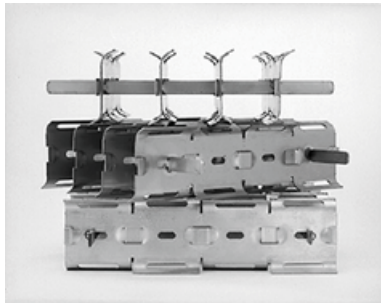

### Main applications

- Vacuum tower wash section
- Atmospheric column over flash section
- Fluid Catalytic Cracker (FCC) main fractionator slurry pump around section
- FCC flue gas scrubber
- Coker main fractionator quench section
- Viscosity breaker main fractionator wash section
- Ethylene primary fractionator
- Ethylene water quench tower

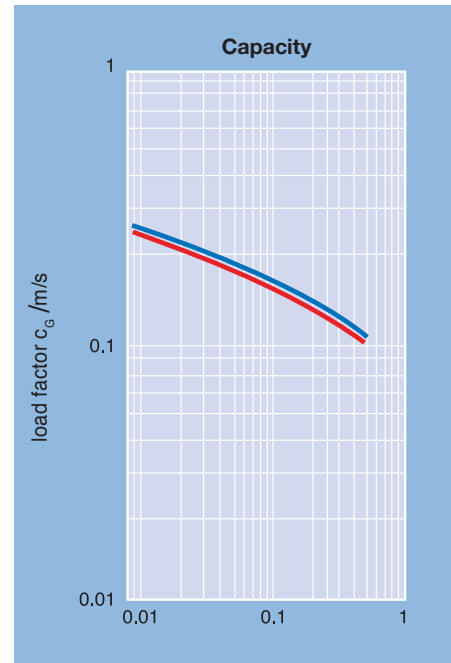

40.Y ■ 64.X ■  
64.Y ■ 90.X ■

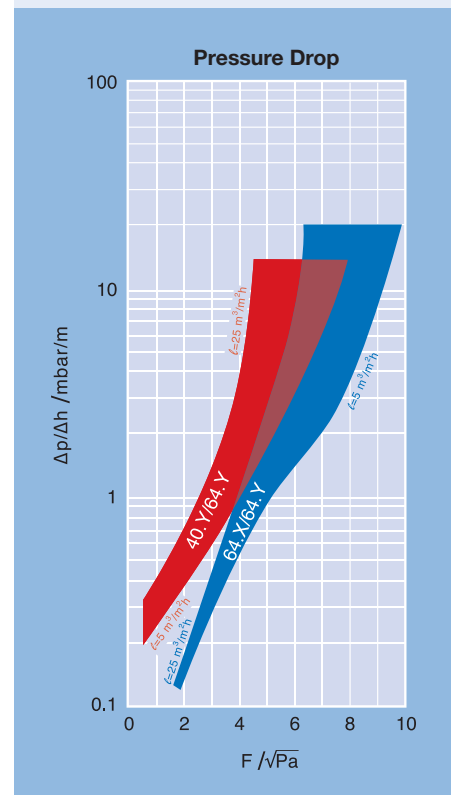

### Mellagrid

Various liquid loads, air/water, T=30°C, atmospheric pressure

# Katapak-SP

For reactive distillation

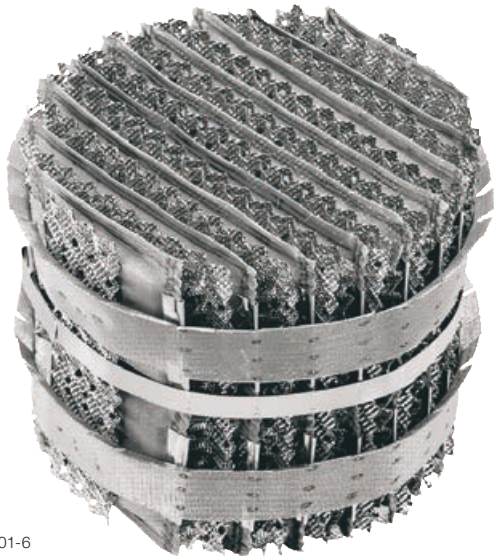

0600 2701-6

This packing was developed to be applied in reactive distillation processes. With the modular concept separation efficiency and catalyst volume fraction can be varied to perfectly fit the requirements of each specific process.

Other types are available on request. Largest diameter supplied to date: 2 m.

## Special features

- Flexible design combining catalyst elements and MellapakPlus layers
- High separation efficiency
- High reaction capacity

## Product applications

- Synthesis of acetates (e.g. butyl acetate)
- Hydrolysis of methyl acetate
- Synthesis of fatty acid esters
- Synthesis of acetals
- MTBE, ETBE, TAME

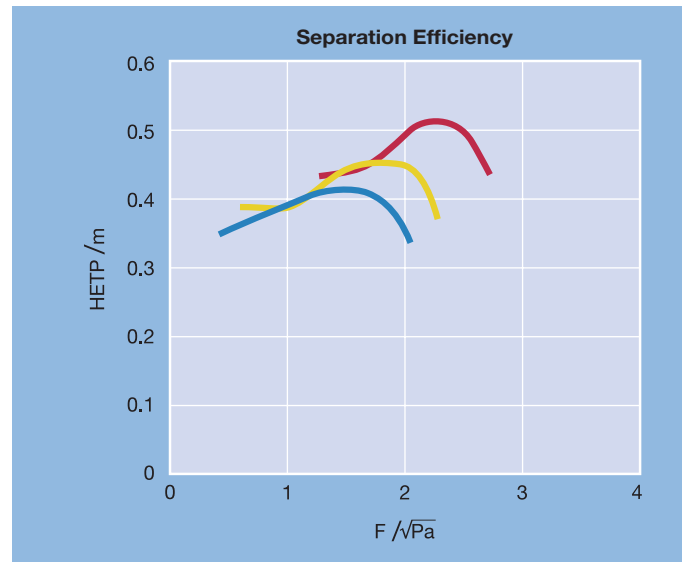

Katapak-SP 12  
960 ———  
400 ———  
100 ———  
parameter = head pressure  $p$  / mbar

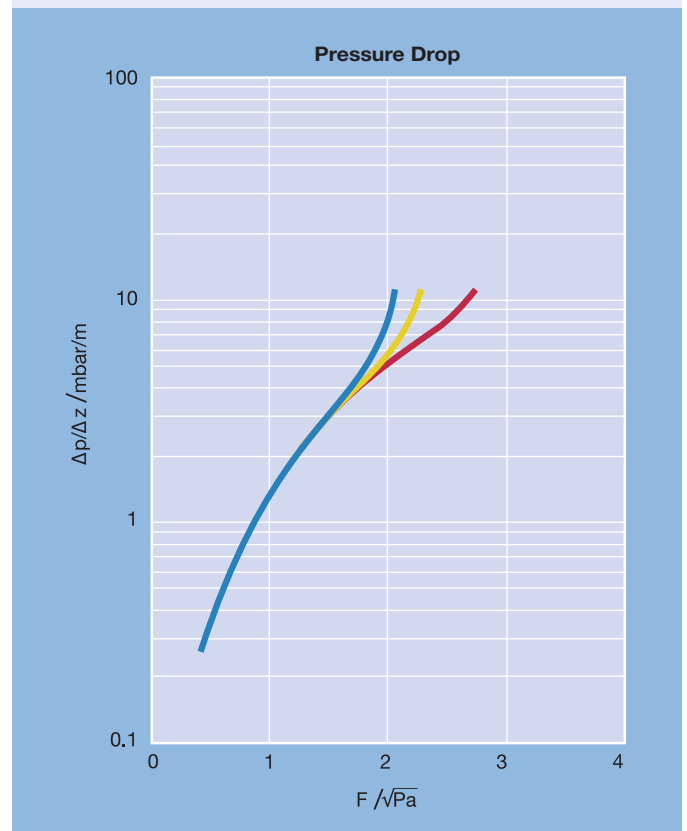

Katapak

# Laboratory packing

For small laboratory columns



0691 2532-2

Standard structured packings are hardly suitable for use in laboratory columns of less than 50 mm diameter. Sulzer laboratory packings are especially designed for this purpose.

Preferred applications:

- Laboratory columns from 20 to 80 mm
- Vacuum from 1 mbar
- Where a high number of theoretical stages is required (DX™, EX™)
- Distillation of components prone to decomposition
- Preliminary assessment of a separation task
- Deriving of reliable scale-up rules

## Special features

Type EX:

- Highest possible number of theoretical stages, even with very low liquid loadings
- Same pressure drop per theoretical stage as Sulzer BX packing
- Small hold-up
- Capacity nearly double that of wire mesh rings (3 x 3 mm)

**Type DX:** This packing has a coarser structure and hence a lower number of theoretical stages.

Suitable for laboratory columns where a modest number of theoretical stages is required, together with low pressure drop and high capacity.

**Type DXM/DYM:** These packing types, made of sheet metal, have a lower number of theoretical stages compared to DX. HETP or NTSM remain constant over a wide range of F factors and liquid loads. This makes scale-up significantly easier.

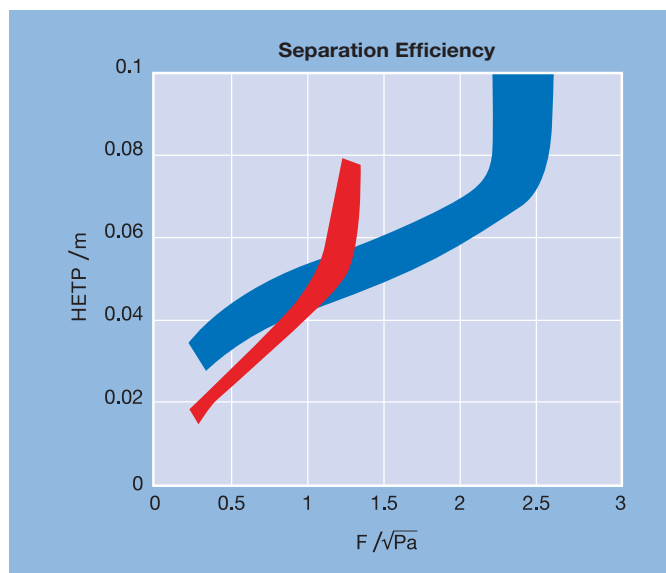

EX

DX

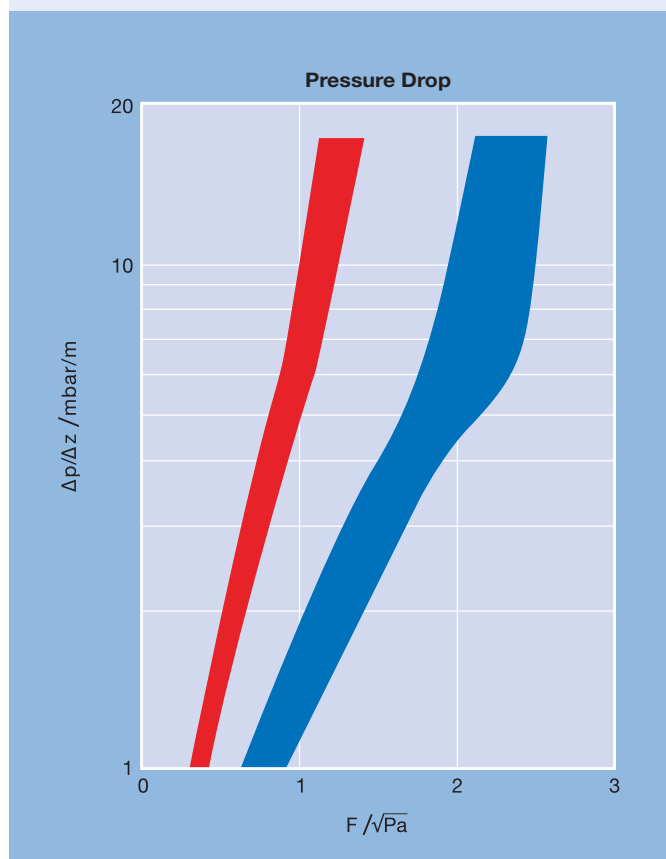

Laboratory packings  
Head pressure = 50 mbar

# Column Internals

## Liquid distributors

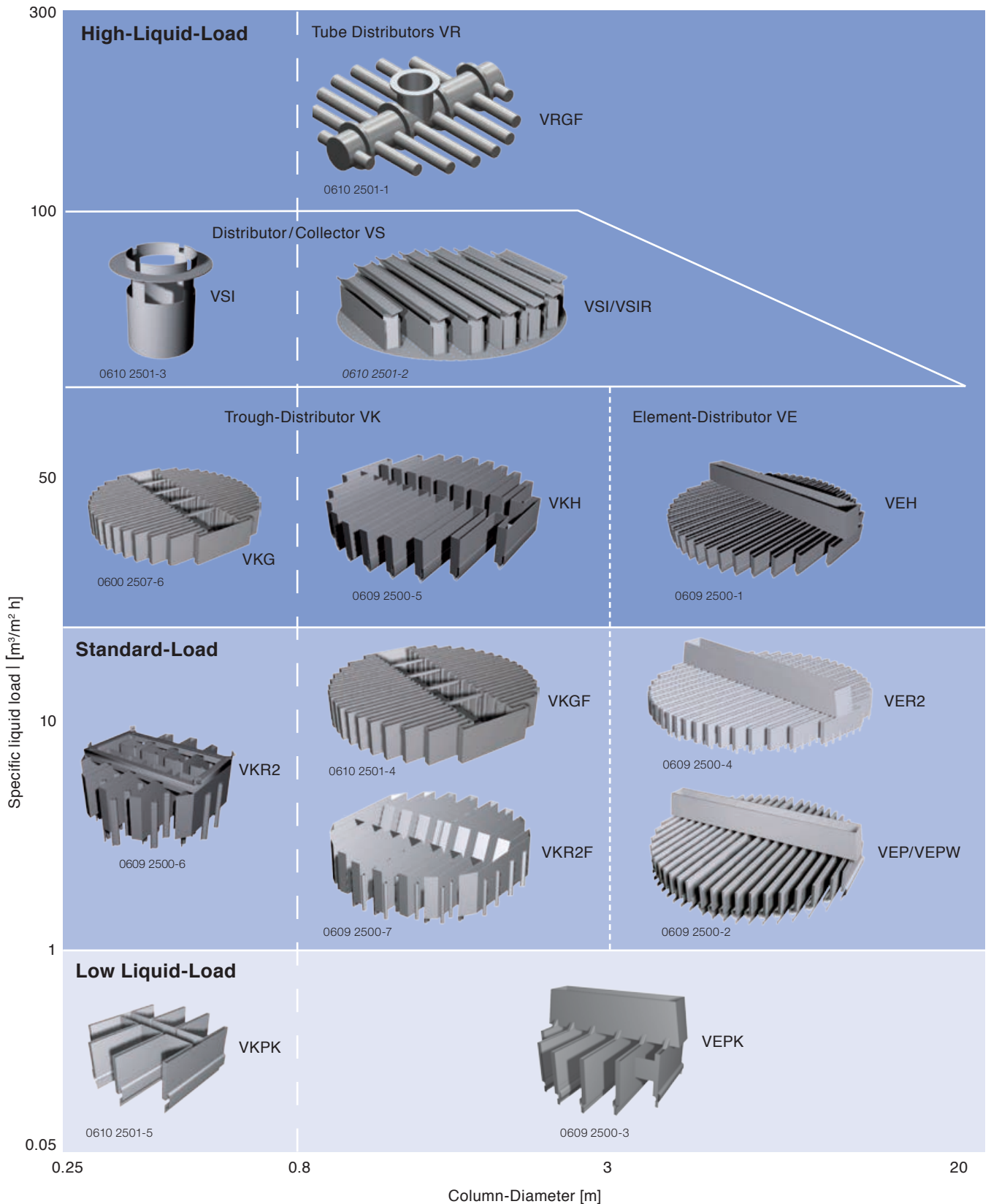



### Collector support grids

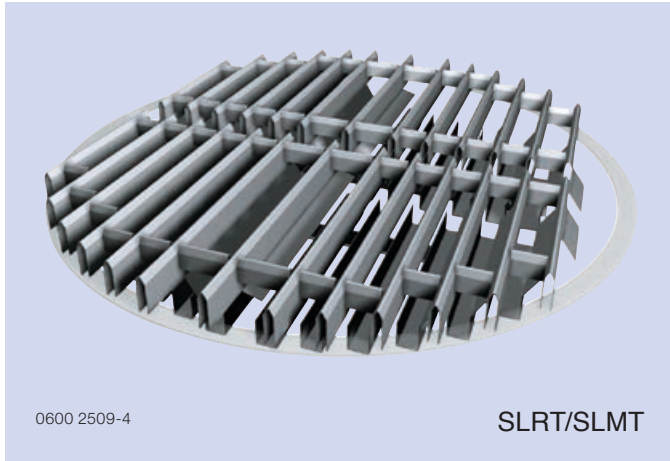

### Collector-distributor systems/Vapor distributor

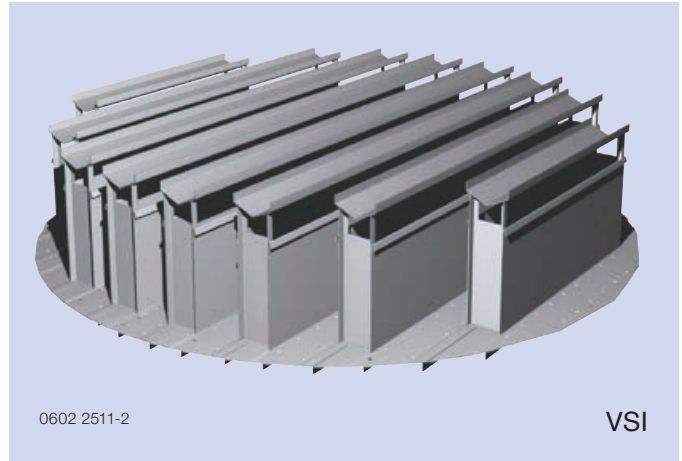

### Collectors

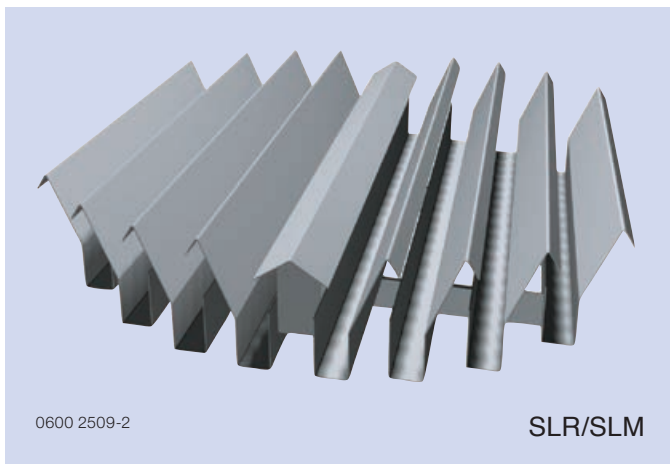

### Support grids

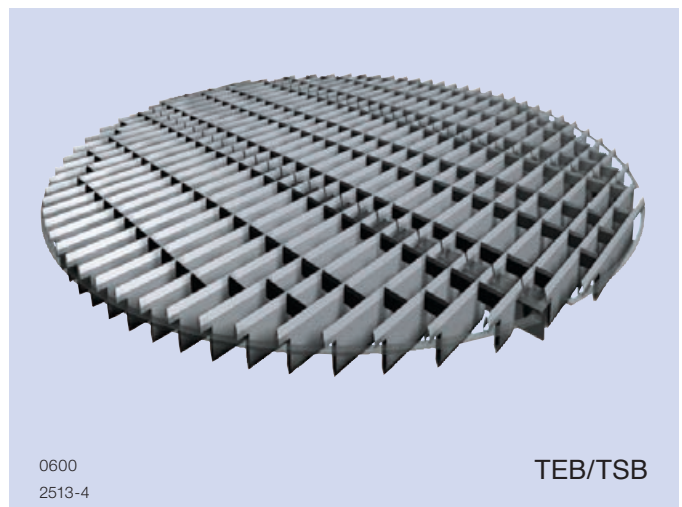

### Chimney trays

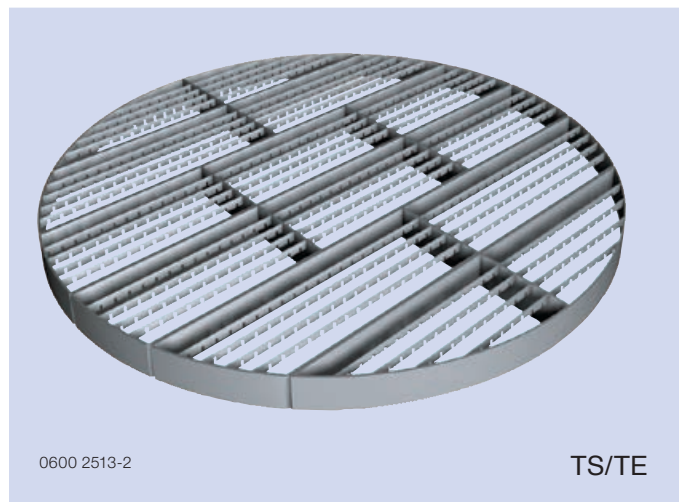
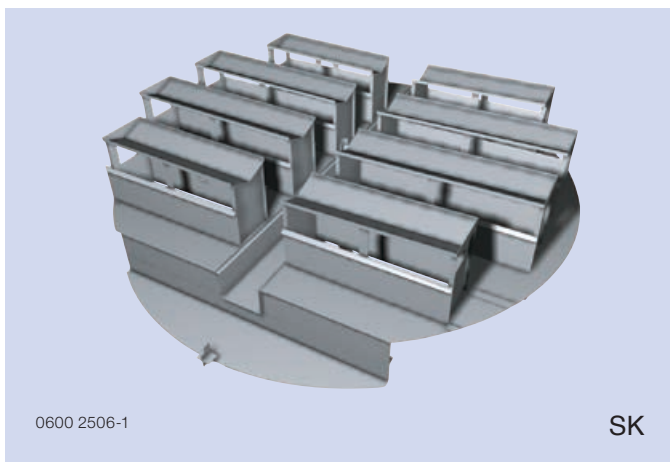

# Comprehensive Engineering and Technology Services

## Customer Hydraulic Design Software SULCOL

SULCOL is the latest development step in our endeavor to provide state-of-the-art tools to our customers for the design of mass transfer columns.

Structured and random packing hydraulic design and rating

- Default packing efficiency based on standard organic test mixtures
- Efficiency calculation may be suppressed
- Extractive distillation
- Graphical capacity diagram with operating points

Tray hydraulic design and rating

- Fixed and movable valves
- One pass and multipass tray design
- Conventional downcomer design
- Description of Sulzer tray portfolio including Shell tray technology

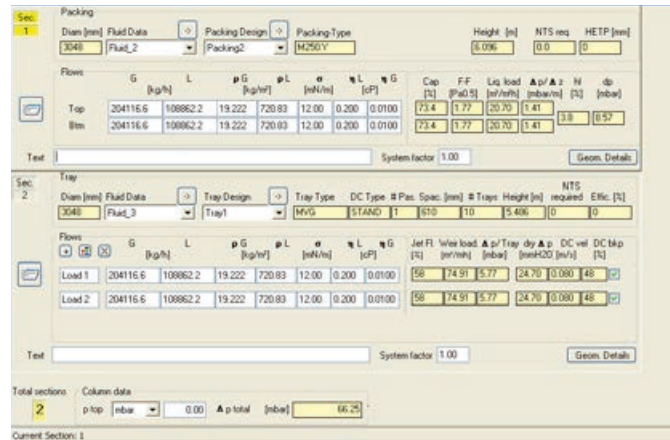

You may download SULCOL from [www.sulzer.com](http://www.sulzer.com)

## Turn Around and Tower Field Services

Sulzer's global manufacturing capabilities ensure fast delivery of any tray hardware and replacement tray parts, regardless of the original supplier.



## Customer Support Services

We combine the array of our technologically advanced products with a full scope of associated engineering and technology services. Tell us your need and leave the rest to us!

### Process Studies

- Energy saving
- Moving columns
- Process optimization
- Troubleshooting

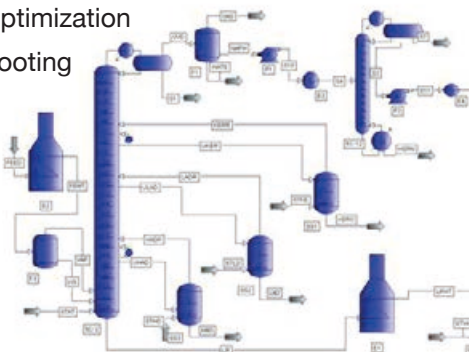

### Laboratory and Pilot Tests

- CO<sub>2</sub> absorption
- High pressure testing up to 50bara
- Gas/Liquid and Liquid/Liquid separation



## Development and Technology

Sulzer makes every effort to support our customers and continuously improve our design tools. Engineers in the R&D lab develop new and improved products, analyze and optimize processes.

We maintain close relationships to universities and independent research organizations to support these efforts.

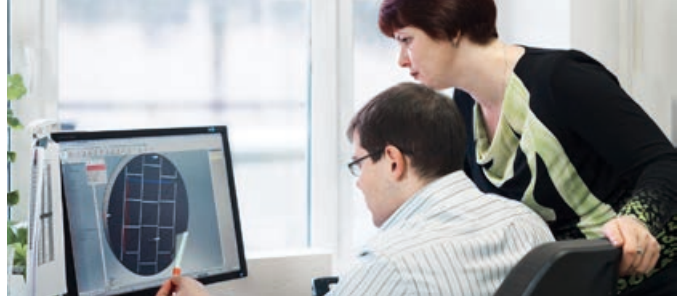

## Engineering and Manufacturing

Sulzer has a long-standing manufacturing tradition. Sulzer owns dedicated factories in every region to produce mixers, columns, reactors, and heat exchangers.

For certain sizes and certain countries, we work with well-known and proven subcontractors who are bound by Sulzer manufacturing policies and quality standards.

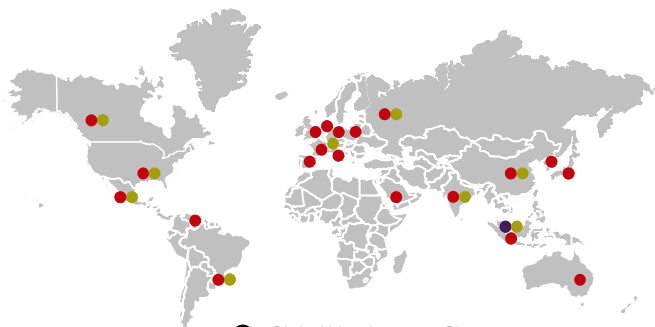

- Global Headquarter: Singapore
- Manufacturing/Service Centre
- Sales offices

## Capabilities

Manufacturing according to PED 97/23/EC, ASME VIII Div.1, and ASME B31.3/U-Stamp, Gost (TR), China Stamp, Norsok, or NACE

Design codes acc. to AD2000, EN 13445, ASME Broad selection of material for construction available

Non-destructive testing (LPT, X-ray, pressure testing up to 500 bar, PMI, MT, UT etc. acc. EN and ASME)

Designing with SolidWorks

Strength calculations, FEM analysis, nozzle loads etc.

Certification for ISO 9001, ISO 14001 and ISO 18001

Experienced project management team

## CFD Analysis

CFD calculations done in advance of fabrication can support the decision to go for a particular technology, and can save on the time required for commissioning and testing later. Sulzer uses CFD technology both for the modeling of existing and the development of new products.

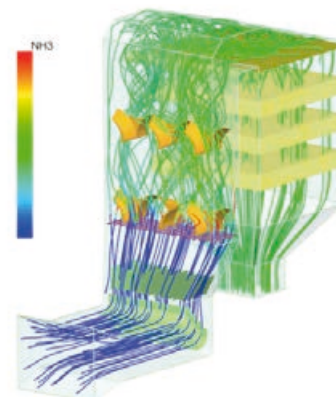

**www.sulzer.com**

Please check for your local contact

Sulzer Chemtech Ltd, a member of the Sulzer Corporation, with headquarters in Winterthur, Switzerland, is active in the field of process engineering and employs some 4000 persons worldwide.

Sulzer Chemtech is represented in all important industrial countries and sets standards in the field of mass transfer and static mixing with its advanced and economical solutions.

The activity program comprises:

- Process components such as fractionation trays, structured and random packings, liquid and gas distributors, gas-liquid separators, and internals for separation columns
- Engineering services for separation and reaction technology such as conceptual process design, feasibilities studies, plant optimizations including process validation in the test center
- Recovery of virtually any solvents used by the pharmaceutical and chemical industry, or difficult separations requiring the combination of special technologies, such as thin film/short-path evaporation, distillation under high vacuum, liquid-liquid extraction, membrane technology or crystallization.
- Complete separation process plants, in particular modular plants (skids)
- Advanced polymerization technology for the production of PLA and EPS
- Tower field services performing tray and packing installation, tower maintenance, welding, and plant turnaround projects
- Mixing and reaction technology with static mixers
- Cartridge-based metering, mixing and dispensing systems, and disposable mixers for reactive multi-component material

Distributed by:

