

DTC	P0171	System Too Lean (Bank 1)
DTC	P0172	System Too Rich (Bank 1)
DTC	P0174	System Too Lean (Bank 2)
DTC	P0175	System Too Rich (Bank 2)

DESCRIPTION

The fuel trim is related to the feedback compensation value, not to the basic injection time. The fuel trim consists of both the short-term and long-term fuel trims.

The short-term fuel trim is fuel compensation that is used to constantly maintain the air-fuel ratio at stoichiometric levels. The signal from the Air-Fuel Ratio (A/F) sensor indicates whether the air-fuel ratio is rich or lean compared to the stoichiometric ratio. This triggers a reduction in the fuel injection volume if the air-fuel ratio is rich and an increase in the fuel injection volume if it is lean.

Factors such as individual engine differences, wear over time and changes in operating environment cause short-term fuel trim to vary from the central value. The long-term fuel trim, which controls overall fuel compensation, compensates for long-term deviations in the fuel trim from the central value caused by the short-term fuel trim compensation.

If both the short-term and long-term fuel trims are lean or rich beyond predetermined values, it is interpreted as a malfunction, and the ECM illuminates the MIL and sets a DTC.

DTC No.	DTC Detection Conditions	Trouble Areas
P0171 P0174	With warm engine and stable air-fuel ratio feedback, fuel trim considerably in error to lean side (2 trip detection logic)	<ul style="list-style-type: none"> • Air induction system • Injector blockage • Mass Air Flow (MAF) meter • Engine Coolant Temperature (ECT) sensor • Fuel pressure • Gas leakage from exhaust system • Open or short in A/F sensor (bank 1, 2 sensor 1) circuit • A/F sensor (bank 1, 2 sensor 1) • A/F sensor heater (bank 1, 2 sensor 1) • A/F sensor heater relay • A/F sensor heater and A/F sensor heater relay circuits • PCV valve and hose • PCV hose connections • ECM
P0172 P0175	With warm engine and stable air-fuel ratio feedback, fuel trim considerably in error to rich side (2 trip detection logic)	<ul style="list-style-type: none"> • Injector leakage or blockage • MAF meter • ECT sensor • Ignition system • Fuel pressure • Gas leakage from exhaust system • Open or short in A/F sensor (bank 1, 2 sensor 1) circuit • A/F sensor (bank 1, 2 sensor 1) • A/F sensor heater (bank 1, 2 sensor 1) • A/F sensor heater relay • A/F sensor heater and A/F sensor heater relay circuits • ECM

HINT:

- When DTC P0171 or P0174 is set, the actual air-fuel ratio is on the lean side. When DTC P0172 or P0175 is set, the actual air-fuel ratio is on the rich side.
- If the vehicle runs out of fuel, the air-fuel ratio is lean and DTC P0171 or P0174 may be set. The MIL is then illuminated.
- When the total of the short-term and long-term fuel trim values is within the malfunction threshold (and the engine coolant temperature is more than 75°C [167°F]), the system is functioning normally.

MONITOR DESCRIPTION

Under closed-loop fuel control, fuel injection volumes that deviate from those estimated by the ECM cause changes in the long-term fuel trim compensation value. The long-term fuel trim is adjusted when there are persistent deviations in the short-term fuel trim values. Deviations from the ECM's estimated fuel injection volumes also affect the average fuel trim learning value, which is a combination of the average short-term fuel trim (fuel feedback compensation value) and the average long-term fuel trim (learning value of the air- fuel ratio). If the average fuel trim learning value exceeds the malfunction thresholds, the ECM interprets this a fault in the fuel system and sets a DTC.

Example:

The average fuel trim learning value is more than +35 % or less than -35 %, the ECM interprets this as a fuel system malfunction.

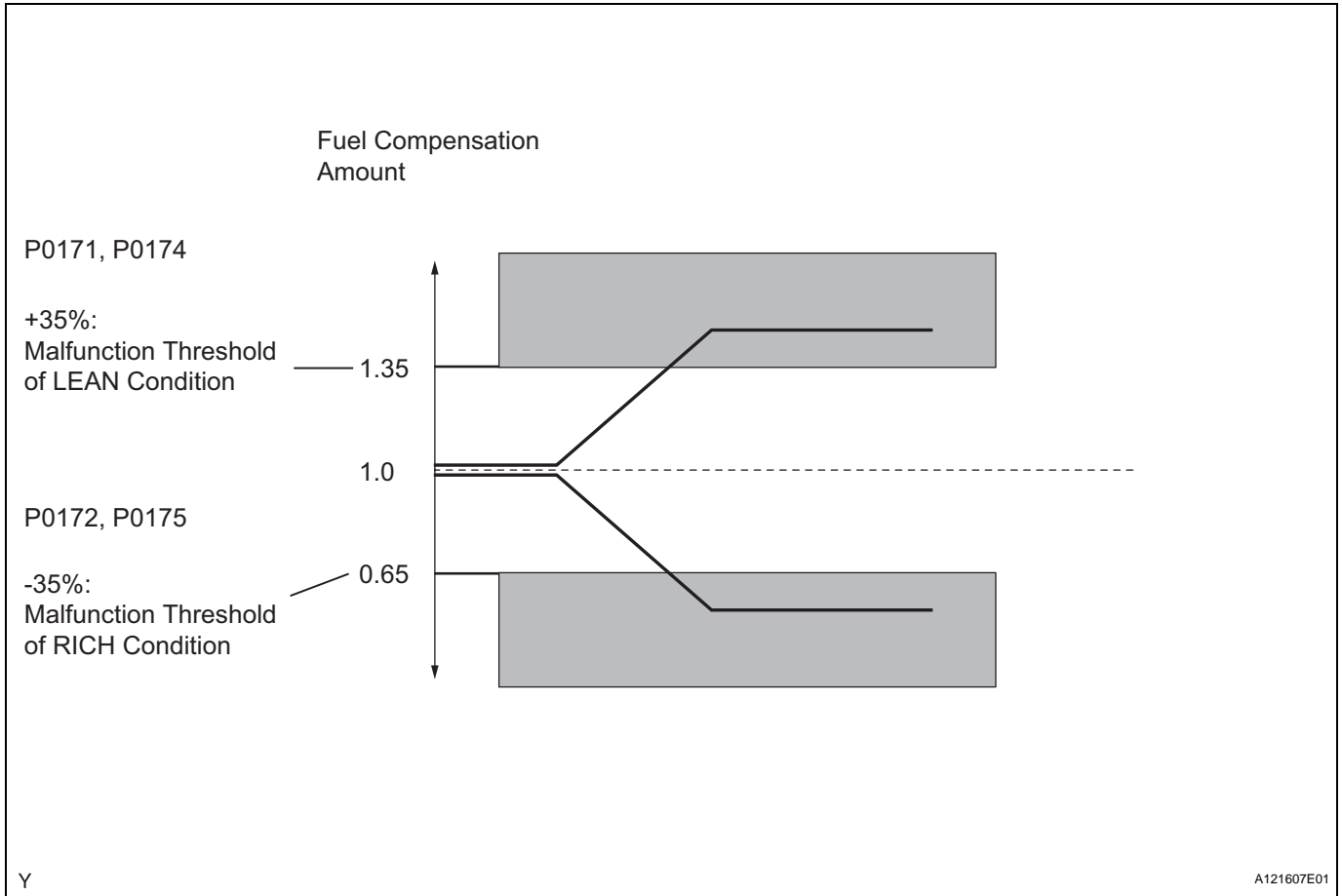

MONITOR STRATEGY

Related DTCs	P0171: Fuel trim Lean (bank 1) P0172: Fuel trim Rich (bank 1) P0174: Fuel trim Lean (bank 2) P0175: Fuel trim Rich (bank 2)
Required Sensors/Components (Main)	Fuel system
Required Sensors/Components (Related)	A/F sensor, Mass air flow meter, Crankshaft position sensor
Frequency of Operation	Continuous
Duration	Within 10 seconds
MIL Operation	2 driving cycles
Sequence of Operation	None

TYPICAL ENABLING CONDITIONS

Fuel-trim:

Monitor runs whenever following DTCs not present	P0010, P0020 (OCV Bank 1, 2) P0011 (VVT System 1 - Advance) P0012 (VVT System 1 - Retard) P0021 (VVT System 2 - Advance) P0022 (VVT System 2 - Retard) P0031, P0032, P0051, P0052 (A/F sensor heater - Sensor 1) P0100 - P0103 (MAF meter) P0115 - P0118 (ECT sensor) P0120 - P0223, P2135 (TP sensor) P0125 (Insufficient ECT for closed loop) P0335 (CKP sensor) P0340 (CMP sensor) P0351 - P0356 (Igniter) P0500 (VSS)
Fuel system status	Closed-loop
Battery voltage	11 V or more
Throttle position learning	Completed
Either of following conditions 1 or 2 set	-
1. Engine RPM	Below 1,100 rpm
2. Intake air amount per revolution	0.22 g/rev or more
Catalyst monitor	No executed

TYPICAL MALFUNCTION THRESHOLDS

Fuel-trim:

Purge-cut	Executing
Either of following conditions 1 or 2 met	-
1. Average between short-term fuel trim and long-term fuel trim	35 % or more at 80°C (176°F) of ECT
2. Average between short-term fuel trim and long-term fuel trim	-35 % or less at 80°C (176°F) of ECT

WIRING DIAGRAM

Refer to DTC P2195 (See page [ES-309](#)).

HINT:

Intelligent tester only:

Malfunctioning areas can be identified by performing the A/F CONTROL function provided in the ACTIVE TEST. The A/F CONTROL function can help to determine whether the Air-Fuel Ratio (A/F) sensor, Heated Oxygen (HO2) sensor and other potential trouble areas are malfunctioning.

The following instructions describe how to conduct the A/F CONTROL operation using an intelligent tester.

- (1) Connect an intelligent tester to the DLC3.
- (2) Start the engine and turn the tester ON.
- (3) Warm up the engine at an engine speed of 2,500 rpm for approximately 90 seconds.
- (4) Select the following menu items: DIAGNOSIS / ENHANCED OBD II / ACTIVE TEST / A/F CONTROL.
- (5) Perform the A/F CONTROL operation with the engine in an idling condition (press the RIGHT or LEFT button to change the fuel injection volume).
- (6) Monitor the voltage outputs of the A/F and HO2 sensors (AFS B1S1 and O2S B1S2 or AFS B2S1 and O2S B2S2) displayed on the tester.

HINT:

- The A/F CONTROL operation lowers the fuel injection volume by 12.5 % or increases the injection volume by 25 %.

- Each sensor reacts in accordance with increases and decreases in the fuel injection volume.

Standard

Tester Display (Sensor)	Injection Volumes	Status	Voltages
AFS B1S1 or AFS B2S1 (A/F)	+25 %	Rich	Less than 3.0
AFS B1S1 or AFS B2S1 (A/F)	-12.5 %	Lean	More than 3.35
O2S B1S2 or O2S B2S2 (HO2)	+25 %	Rich	More than 0.55
O2S B1S2 or O2S B2S2 (HO2)	-12.5 %	Lean	Less than 0.4

NOTICE:

The Air-Fuel Ratio (A/F) sensor has an output delay of a few seconds and the Heated Oxygen (HO2) sensor has a maximum output delay of approximately 20 seconds.



Case	A/F Sensor (Sensor 1) Output Voltage		HO2 Sensor (Sensor 2) Output Voltage		Main Suspected Trouble Areas
1	Injection volume +25 % -12.5 %		Injection volume +25 % -12.5 %		-
	Output voltage More than 3.35 V Less than 3.0 V		Output voltage More than 0.55 V Less than 0.4 V		
2	Injection volume +25 % -12.5 %		Injection volume +25 % -12.5 %		<ul style="list-style-type: none"> • A/F sensor • A/F sensor heater • A/F sensor circuit
	Output voltage Almost no reaction		Output voltage More than 0.55 V Less than 0.4 V		
3	Injection volume +25 % -12.5 %		Injection volume +25 % -12.5 %		<ul style="list-style-type: none"> • HO2 sensor • HO2 sensor heater • HO2 sensor circuit
	Output voltage More than 3.35 V Less than 3.0 V		Output voltage Almost no reaction		
4	Injection volume +25 % -12.5 %		Injection volume +25 % -12.5 %		<ul style="list-style-type: none"> • Injector • Fuel pressure • Gas leakage from exhaust system (Air-fuel ratio extremely lean or rich)
	Output voltage Almost no reaction		Output voltage Almost no reaction		

- Following the A/F CONTROL procedure enables technicians to check and graph the voltage outputs of both the A/F and HO2 sensors.
- To display the graph, select the following menu items on the tester: DIAGNOSIS / ENHANCED OBD II / ACTIVE TEST / A/F CONTROL / USER DATA / AFS B1S1 and O2S B1S2 or AFS B2S1 and O2S B2S2, and press the YES button and then the ENTER button followed by the F4 button.

HINT:

- Read freeze frame data using an intelligent tester. Freeze frame data record the engine condition when malfunctions are detected. When troubleshooting, freeze frame data can help determine if the vehicle was moving or stationary, if the engine was warmed up or not, if the air-fuel ratio was lean or rich, and other data, from the time the malfunction occurred.

- A low A/F sensor voltage could be caused by a rich air-fuel mixture. Check for conditions that would cause the engine to run rich.
- A high A/F sensor voltage could be caused by a lean air-fuel mixture. Check for conditions that would cause the engine to run lean.

1 CHECK ANY OTHER DTCS OUTPUT (IN ADDITION TO DTC P0171, P0172, P0174 OR P0175)

- (a) Connect an intelligent tester to the DLC3.
- (b) Turn the ignition switch ON and turn the tester ON.
- (c) Select the following menu items: DIAGNOSIS / ENHANCED OBD II / DTC INFO / CURRENT CODES.
- (d) Read DTCs.

ES

Result

Display (DTC output)	Proceed To
P0171, P0172, P0174 or P0175	A
P0171, P0172, P0174 or P0175 and other DTCs	B

HINT:

If any DTCs other than P0171, P0172, P0174 or P0175 are output, troubleshoot those DTCs first.

B → **GO TO DTC CHART**

A

2 CHECK PCV HOSE CONNECTIONS

OK:

PCV hose is connected correctly and is not damaged.

NG → **REPAIR OR REPLACE PCV HOSE**

OK

3 CHECK AIR INDUCTION SYSTEM

- (a) Check the air induction system for vacuum leakage.

OK:

No leakage from air induction system.

NG → **REPAIR OR REPLACE AIR INDUCTION SYSTEM**

OK

4 PERFORM ACTIVE TEST USING INTELLIGENT TESTER (A/F CONTROL)

- (a) Connect an intelligent tester to the DLC3.
- (b) Start the engine and turn the tester ON.
- (c) Warm up the engine at an engine speed of 2,500 rpm for approximately 90 seconds.
- (d) Select the following menu items: DIAGNOSIS / ENHANCED OBD II / ACTIVE TEST / A/F CONTROL.

- (e) Perform the A/F CONTROL operation with the engine in an idling condition (press the RIGHT or LEFT button to change the fuel injection volume).
- (f) Monitor the voltage outputs of A/F and HO2 sensors (AFS B1S1 and O2S B1S2 or AFS B2S1 and O2S B2S2) displayed on the tester.

HINT:

- The A/F CONTROL operation lowers the fuel injection volume by 12.5 % or increases the injection volume by 25 %.
- Each sensor reacts in accordance with increases and decreases in the fuel injection volume.

Standard

Tester Display (Sensor)	Injection Volumes	Status	Voltages
AFS B1S1 or AFS B2S1 (A/F)	+25 %	Rich	Less than 3.0
AFS B1S1 or AFS B2S1 (A/F)	-12.5 %	Lean	More than 3.35
O2S B1S2 or O2S B2S2 (HO2)	+25 %	Rich	More than 0.55
O2S B1S2 or O2S B2S2 (HO2)	-12.5 %	Lean	Less than 0.4

Result:

Status AFS B1S1 or AFS B2S1	Status O2S B1S2 or O2S B2S2	A/F Condition and A/F Sensor Condition	Misfires	Suspected Trouble Areas	Proceed To
Lean/Rich	Lean/Rich	Normal	-	-	C
Lean	Lean	Actual air-fuel ratio lean	May occur	<ul style="list-style-type: none"> • PCV valve and hose • PCV hose connections • Injector blockage • Gas leakage from exhaust system • Air induction system • Fuel pressure • Mass Air Flow (MAF) meter • Engine Coolant Temperature (ECT) sensor 	A
Rich	Rich	Actual air-fuel ratio rich	-	<ul style="list-style-type: none"> • Injector blockage or blockage • Gas leakage from exhaust system • Ignition system • Fuel pressure • MAF meter • ECT sensor 	
Lean	Lean/Rich	A/F sensor malfunction	-	• A/F sensor	B
Rich	Lean/Rich	A/F sensor malfunction	-	• A/F sensor	

Lean: During A/F CONTROL, the A/F sensor output voltage (AFS) is consistently more than 3.35 V, and the HO2 sensor output voltage (O2S) is consistently less than 0.4 V.

Rich: During A/F CONTROL, the AFS is consistently less than 3.0 V, and the O2S is consistently more than 0.55 V.

Lean/Rich: During A/F CONTROL of the ACTIVE TEST, the output voltage of the heated oxygen sensor alternates correctly.



C

Go to step 15

A

5

READ VALUE OF INTELLIGENT TESTER (COOLANT TEMP)

- (a) Connect an intelligent tester to the DLC3.
- (b) Turn the ignition switch ON and turn the tester ON.
- (c) Select the following menu items: DIAGNOSIS / ENHANCED OBD II / DATA LIST / PRIMARY / COOLANT TEMP.
- (d) Read the COOLANT TEMP twice, when the engine is both cold and warmed up.

Standard:

With cold engine: Same as ambient air temperature.

With warm engine: Between 80°C and 100°C (176°F and 212°F).

NG

REPLACE ENGINE COOLANT TEMPERATURE SENSOR

OK

6

READ VALUE OF INTELLIGENT TESTER (MAF)

- (a) Connect an intelligent tester to the DLC3.
- (b) Turn the ignition switch ON and turn the tester ON.
- (c) Select the following menu items: DIAGNOSIS / ENHANCED OBD II / DATA LIST / PRIMARY / MAF and COOLANT TEMP.
- (d) Allow the engine to idle until the COOLANT TEMP reaches 75°C (167°F) or more.
- (e) Read the MAF with the engine in an idling condition and at an engine speed of 2,500 rpm.

Standard:

MAF while engine idling: Between 3.2 g/sec and 4.7 g/sec (shift position: N, A/C: OFF).

MAF at engine speed of 2,500 rpm: Between 13.1 g/sec and 18.9 g/sec (shift position: N, A/C: OFF).

NG

REPLACE MASS AIR FLOW METER

OK

7

CHECK FUEL PRESSURE

- (a) Check the fuel pressure (See page [FU-6](#)).

NG

REPAIR OR REPLACE FUEL SYSTEM

OK

8 CHECK EXHAUST GAS LEAKAGE

OK:
No gas leakage.

NG → **REPAIR OR REPLACE EXHAUST SYSTEM**

OK

9 CHECK SPARK AND IGNITION

HINT:
If the spark plugs or ignition system malfunctions, engine misfire may occur. The misfire count can be read using an intelligent tester. Select the following menu items: DIAGNOSIS / ENHANCED OBD II / DATA LIST / PRIMARY / CYL #1 (to CYL #6).

NG → **REPAIR OR REPLACE IGNITION SYSTEM**

OK

10 INSPECT FUEL INJECTOR ASSEMBLY (INJECTION AND VOLUME)

HINT:
If the injectors malfunction, engine misfire may occur. The misfire count can be read using an intelligent tester. Select the following menu items: DIAGNOSIS / ENHANCED OBD II / DATA LIST / PRIMARY / CYL #1 (to CYL #6).

NG → **REPLACE FUEL INJECTOR ASSEMBLY**

OK

11 INSPECT AIR FUEL RATIO SENSOR (HEATER RESISTANCE)

Component Side:

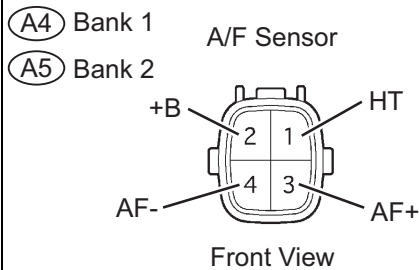

- (a) Disconnect the A4 or A5 A/F sensor connector.
- (b) Measure the resistance between the terminals of the A/F sensor connector.

Standard Resistance

Tester Connections	Specified Conditions
HT (1) - +B (2)	1.8 Ω to 3.4 Ω at 20°C (68°F)
HT (1) - AF- (4)	10 kΩ or higher

- (c) Reconnect the A/F sensor connector.

NG → **REPLACE AIR FUEL RATIO SENSOR**

OK

12 INSPECT AIR FUEL RATIO SENSOR HEATER RELAY

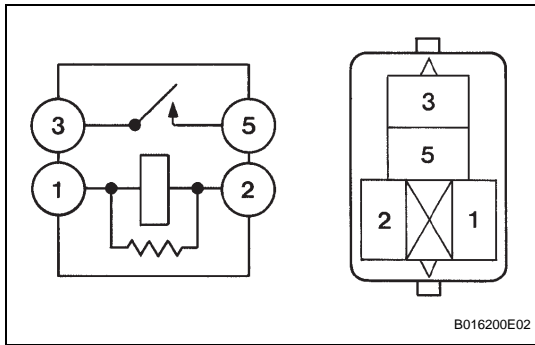

(a) Remove the A/F sensor heater relay from the engine room R/B.

(b) Check the A/F sensor heater relay resistance.
Standard Resistance

Tester Connections	Specified Conditions
3 - 5	10 kΩ or higher
3 - 5	Below 1 Ω (when battery voltage applied to terminals 1 and 2)

(c) Reinstall the A/F sensor heater relay.

NG → **REPLACE AIR FUEL RATIO SENSOR HEATER RELAY**

OK

13 CHECK HARNESS AND CONNECTOR (A/F SENSOR - ECM)

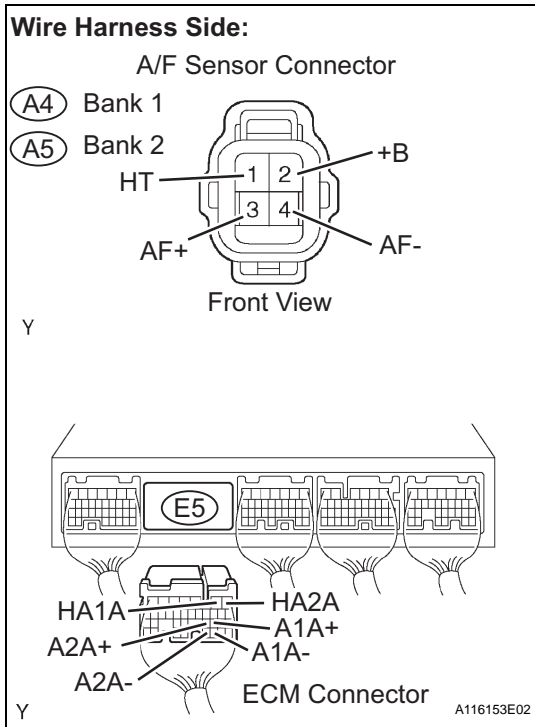

(a) Disconnect the A4 or A5 A/F sensor connector.
(b) Turn the ignition switch ON.

(c) Measure the voltage between the +B terminal of the A/F sensor connector and body ground.
Standard Voltage

Tester Connections	Specified Conditions
+B (A4-2) - Body ground	9 to 14 V
+B (A5-2) - Body ground	

(d) Turn the ignition switch OFF.
(e) Disconnect the E5 ECM connector.
(f) Check the resistance.
Standard Resistance (Check for open)

Tester Connections	Specified Conditions
HT (A4-1) - HA1A (E5-2)	Below 1 Ω
AF+ (A4-3) - A1A+ (E5-22)	
AF- (A4-4) - A1A- (E5-30)	
HT (A5-1) - HA2A (E5-1)	
AF+ (A5-3) - A2A+ (E5-23)	
AF- (A5-4) - A2A- (E5-31)	

Standard Resistance (Check for short)

Tester Connections	Specified Conditions
HT (A4-1) or HA1A (E5-2) - Body ground	10 kΩ or higher
AF+ (A4-3) or A1A+ (E5-22) - Body ground	
AF- (A4-4) or A1A- (E5-30) - Body ground	
HT (A5-1) or HA2A (E5-1) - Body ground	
AF+ (A5-3) or A2A+ (E5-23) - Body ground	
AF- (A5-4) or A2A- (E5-31) - Body ground	

(g) Reconnect the ECM connector.
(h) Reconnect the A/F sensor connector.

Reference (Bank 1 Sensor 1 System Diagram)

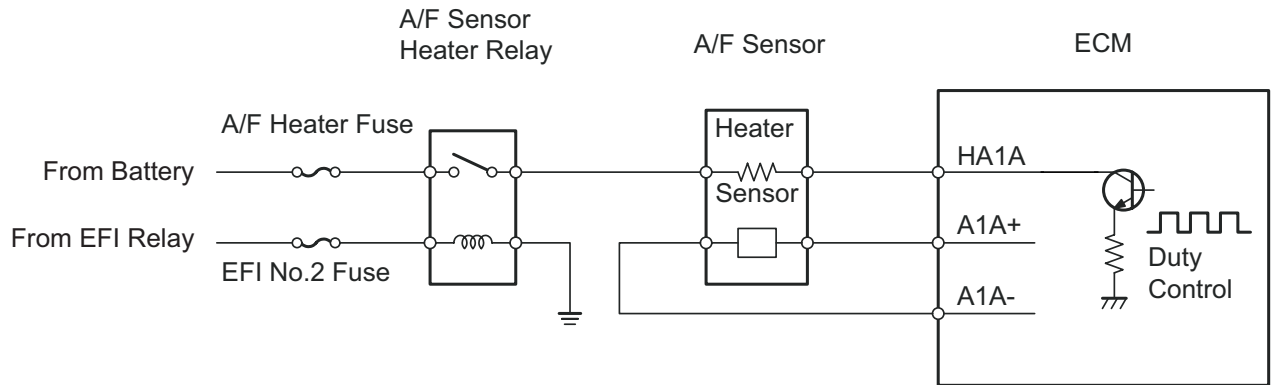

A115897E03

NG **REPAIR OR REPLACE HARNESS OR CONNECTOR**

ES

OK

14 **REPLACE AIR FUEL RATIO SENSOR**

(a) Replace the A/F sensor (See page [EC-17](#)).

NEXT

15 PERFORM CONFIRMATION DRIVING PATTERN

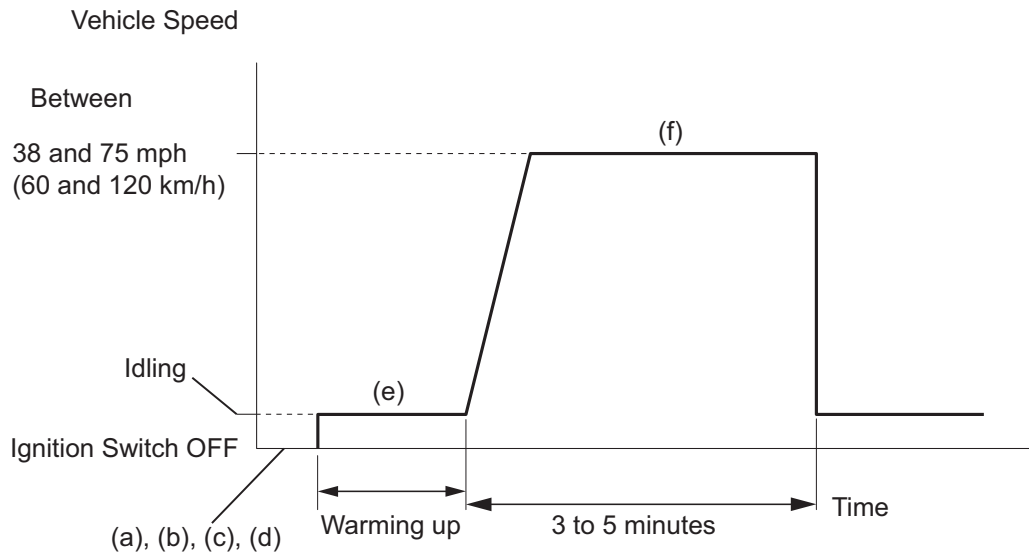

P

A115372E10

- (a) Connect an intelligent tester to the DLC3.
- (b) Turn the ignition switch ON and turn the tester ON.
- (c) Clear DTCs (See page [ES-38](#)).
- (d) Switch the ECM from normal mode to check mode using the tester (See page [ES-41](#)).
- (e) Start the engine and warm it up with all the accessories switched OFF.
- (f) Drive the vehicle at between 38 mph and 75 mph (60 km/h and 120 km/h) and at an engine speed of between 1,400 rpm and 3,200 rpm for 3 to 5 minutes.

HINT:

If the system is still malfunctioning, the MIL will be illuminated during step (f).

NOTICE:

If the conditions in this test are not strictly followed, no malfunction will be detected.

NEXT

16 CHECK WHETHER DTC OUTPUT RECURS (DTC P0171, P0172, P0174 OR P0175)

- (a) Connect an intelligent tester to the DLC3.
- (b) Turn the ignition switch ON and turn the tester ON.
- (c) Select the following menu items: DIAGNOSIS / ENHANCED OBD II / DTC INFO / CURRENT CODES.
- (d) Read DTCS.

Result

Display (DTC output)	Proceed To
No output	A
P0171, P0172, P0174 or P0175	B



Go to step 5



END