

DTC	P2A00	A/F Sensor Circuit Slow Response (Bank 1 Sensor 1)
------------	--------------	---

HINT:

Sensor 1 refers to the sensor mounted in front of the Three-Way Catalytic Converter (TWC) and located near the engine assembly.

DESCRIPTION

Refer to DTC P2195 (See page [ES-312](#)).

DTC No.	DTC Detection Conditions	Trouble Areas
P2A00	Calculated value for air-fuel ratio (A/F) sensor response rate deterioration level is less than threshold	<ul style="list-style-type: none"> • Open or short in A/F sensor circuit • A/F sensor • ECM

ES

MONITOR DESCRIPTION

After engine is warmed up, the ECM performs air-fuel ratio feedback control to maintain the air-fuel ratio at the stoichiometric level. In addition, active A/F ratio control is performed for approximately 10 seconds after preconditions are met in order to measure the A/F sensor response rate. During active A/F ratio control, the ECM forcibly increases and decreases the injection volume a certain amount, based on the stoichiometric air-fuel ratio learned during normal air-fuel ratio control, and measures the A/F sensor response rate. The ECM receives a signal from the A/F sensor while performing active A/F ratio control and uses it to calculate the A/F sensor response rate deterioration level.

If the value for A/F sensor response rate deterioration level is less than threshold, the ECM interprets this as a malfunction and sets the DTC.

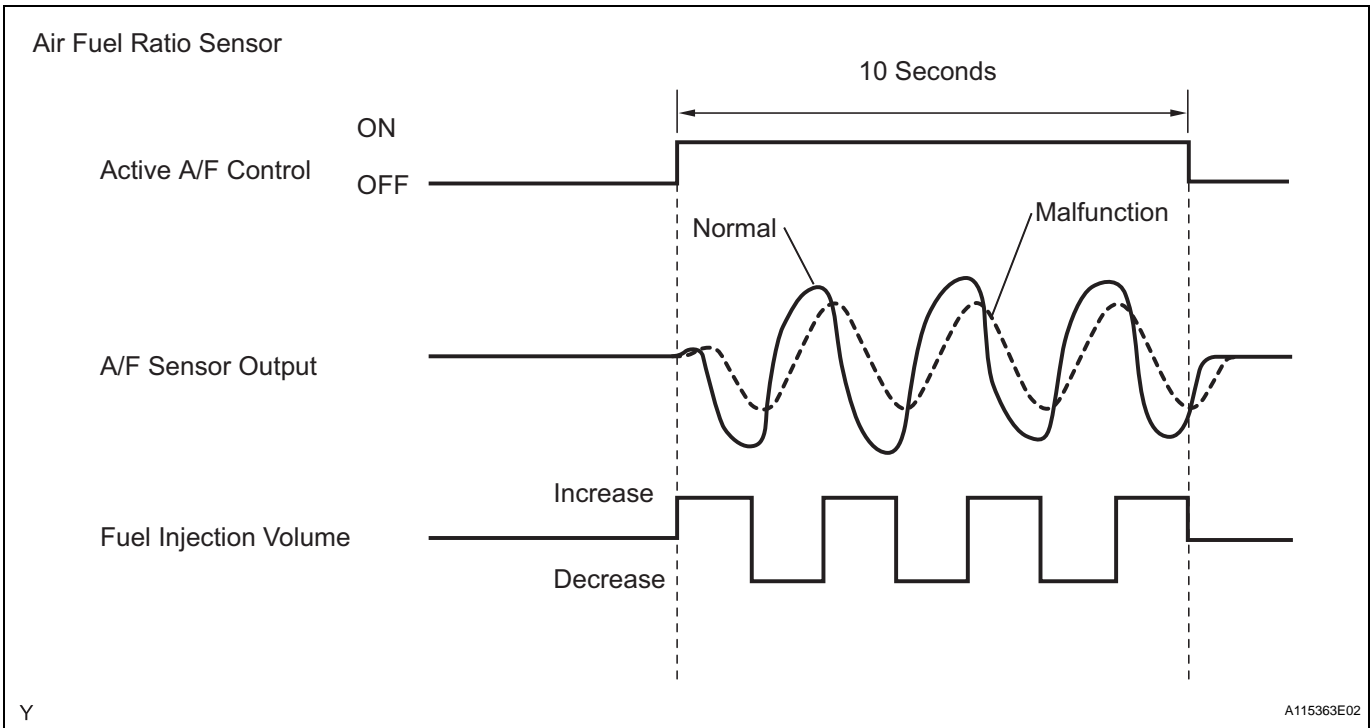

CONFIRMATION DRIVING PATTERN

HINT:

Performing this confirmation pattern will activate the A/F sensor response monitor.

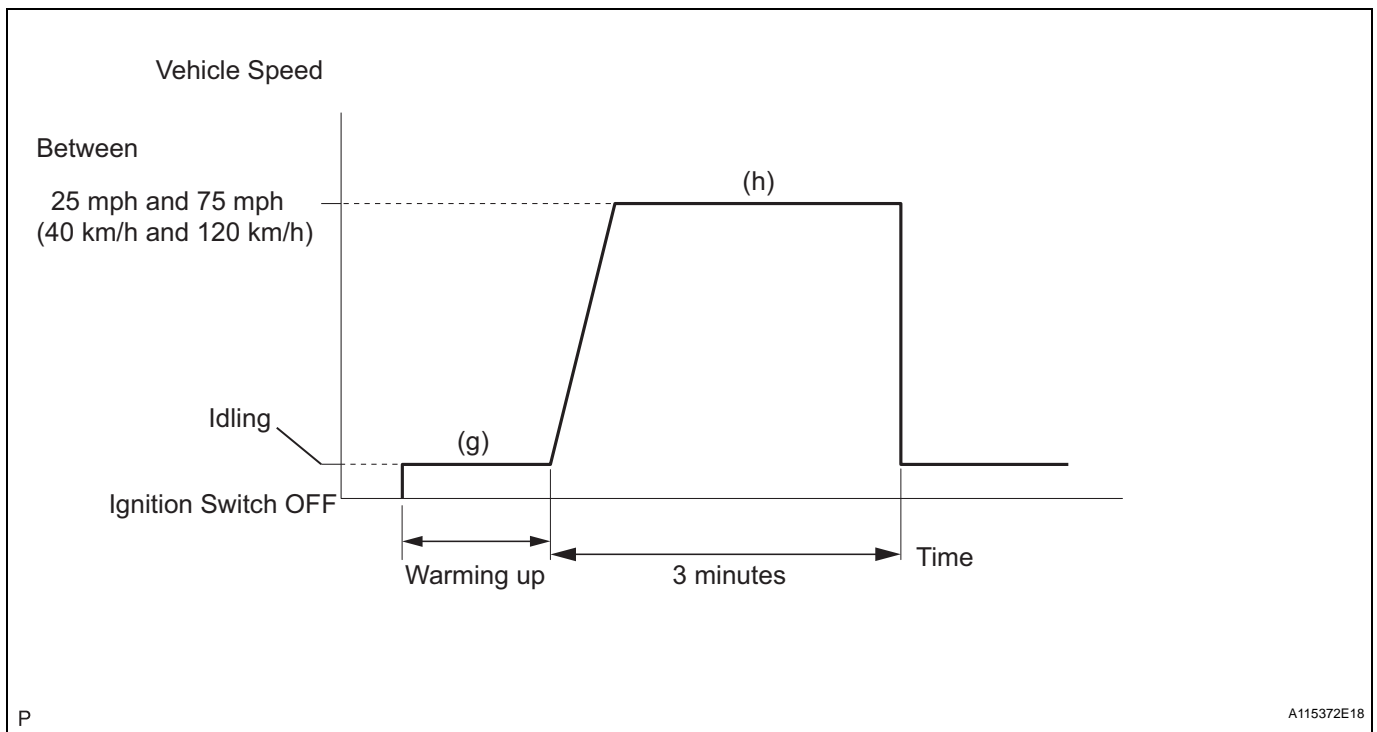

(a) Connect an intelligent tester to the DLC3.

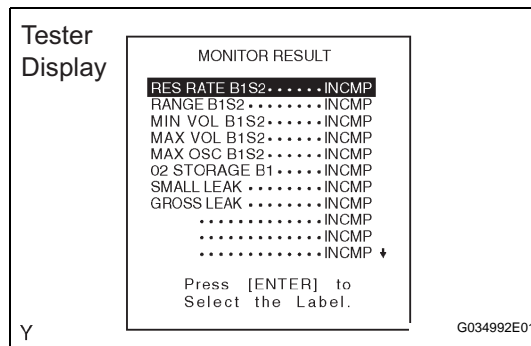

(b) Turn the ignition switch to ON.

(c) Turn the tester ON.

(d) Clear DTCs (where set).

(e) Select the following menu items: DIAGNOSIS / ENHANCED OBD II / MONITOR INFO / MONITOR RESULT.

(f) Check that RES RATE B1S1 is INCOMP.

(g) Start the engine and warm it up.

(h) Drive the vehicle at between 25 mph and 75 mph (40 km/h and 120 km/h) for 3 minutes. However, the vehicle should be driven at a constant speed.

(i) Check the monitor result values on the intelligent tester by selecting the following menu items: DIAGNOSIS / ENHANCED OBD II / MONITOR INFO / TEST RESULT.

(j) If the values indicated on the tester do not change, perform READINESS MONITOR DRIVE PATTERN for the A/F sensor and the heated oxygen sensor (see page [ES-25](#)).

HINT:

Completion of all A/F sensor monitors is required to change the value in TEST RESULT.

(k) Note the value of the Monitor Result.

(l) Select the following menu items: DIAGNOSIS / ENHANCED OBD II / DTC INFO / PENDING CODES.

(m) Check if any DTCs (any pending DTCs) are set.

MONITOR STRATEGY

Related DTCs	P2A00: Air-Fuel Ratio (A/F) sensor slow response
Required Sensors/Components (Main)	A/F sensor
Required Sensors/Components (Related)	Vehicle speed sensor, Crankshaft position sensor
Frequency of Operation	Once per driving cycle
Duration	10 to 15 seconds
MIL Operation	2 driving cycles
Sequence of Operation	None

TYPICAL ENABLING CONDITIONS

ES Monitor runs whenever following DTCs not present	P0031, P0032, P0051, P0052 (A/F sensor heater - Sensor 1) P0100 - P0103 (MAF meter) P0110 - P0113 (IAT sensor) P0115 - P0118 (ECT sensor) P0120 - P0223, P2135 (TP sensor) P0125 (Insufficient ECT for Closed Loop) P0171, P0172 (Fuel system) P0300 - P0308 (Misfire) P0335 (CKP sensor) P0340, P0341 (CMP sensor) P0442 - P0456 (EVAP system) P0500 (VSS) P2196, P2198 (A/F sensor - rationality) P2440 (A/R control valve stuck open) P2441 (A/R control valve stuck close) P2444 (AIP stuck ON) P2445 (AIP stuck OFF)
A/F sensor active control	Executing
Engine coolant temperature	70°C (158°F) or more
Battery voltage	11 V or more
Malfunction determination in this driving cycle	Not yet
Engine RPM	Less than 4,000 rpm
Fuel system status	Closed-loop
A/F sensor status	Activated
Fuel-cut	OFF (for 5 seconds or more)
Engine load	10 to 70 %
Shift position	2nd or more
Intake air amount	3 to 14 g/sec

TYPICAL MALFUNCTION THRESHOLDS

Response rate deterioration level	Less than 0.2 V
-----------------------------------	-----------------

MONITOR RESULT

Refer to Checking Monitor Status (See page [ES-21](#)).

WIRING DIAGRAM

Refer to DTC P2195 (See page [ES-316](#)).

HINT:

Malfunctioning areas can be identified by performing the A/F CONTROL function provided in the ACTIVE TEST. The A/F CONTROL function can help to determine whether the Air-Fuel Ratio (A/F) sensor, Heated Oxygen (HO₂) sensor and other potential trouble areas are malfunctioning.

The following instructions describe how to conduct the A/F CONTROL operation using an intelligent tester.

1. Connect an intelligent tester to the DLC3.
2. Start the engine and turn the tester ON.
3. Warm up the engine at an engine speed of 2,500 rpm for approximately 90 seconds.
4. On the tester, select the following menu items: DIAGNOSIS / ENHANCED OBD II / ACTIVE TEST / A/F CONTROL.
5. Perform the A/F CONTROL operation with the engine in an idling condition (press the RIGHT or LEFT button to change the fuel injection volume).
6. Monitor the voltage outputs of the A/F and HO2 sensors (AFS B1S1 and OS2 B1S2) displayed on the tester.

HINT:













- The A/F CONTROL operation lowers the fuel injection volume by 12.5 % or increases the injection volume by 25 %.
- Each sensor reacts in accordance with increases and decreases in the fuel injection volume.



Standard Voltage

Tester Display (Sensor)	Injection Volumes	Status	Voltages
AFS B1S1 (A/F)	+25 %	Rich	Less than 3.0
AFS B1S1 (A/F)	-12.5 %	Lean	More than 3.35
O2S B1S2 (HO2)	+25 %	Rich	More than 0.5
O2S B1S2 (HO2)	-12.5 %	Lean	Less than 0.4

NOTICE:

The Air-Fuel Ratio (A/F) sensor has an output delay of a few seconds and the Heated Oxygen (HO2) sensor has a maximum output delay of approximately 20 seconds.

Case	A/F Sensor (Sensor 1) Output Voltage		HO2 Sensor (Sensor 2) Output Voltage		Main Suspected Trouble Areas
1	Injection Volume +25 % -12.5 %		Injection Volume +25 % -12.5 %		-
	Output Voltage More than 3.35 V Less than 3.0 V		Output Voltage More than 0.5 V Less than 0.4 V		
2	Injection Volume +25 % -12.5 %		Injection Volume +25 % -12.5 %		<ul style="list-style-type: none"> • A/F sensor • A/F sensor heater • A/F sensor circuit
	Output Voltage Almost no reaction		Output Voltage More than 0.5 V Less than 0.4 V		
3	Injection Volume +25 % -12.5 %		Injection Volume +25 % -12.5 %		<ul style="list-style-type: none"> • HO2 sensor • HO2 sensor heater • HO2 sensor circuit
	Output Voltage More than 3.35 V Less than 3.0 V		Output Voltage Almost no reaction		

Case	A/F Sensor (Sensor 1) Output Voltage		HO2 Sensor (Sensor 2) Output Voltage		Main Suspected Trouble Areas
4	Injection volume +25 % -12.5 %		Injection Volume +25 % -12.5 %		<ul style="list-style-type: none"> • Injector • Fuel pressure • Gas leakage from exhaust system (Air-fuel ratio extremely lean or rich)
	Output Voltage Almost no reaction	—————NG	Output voltage Almost no reaction	—————NG	

- Following the A/F CONTROL procedure enables technicians to check and graph the voltage outputs of both the A/F and HO2 sensors.
- To display the graph, select the following menu items on the tester: DIAGNOSIS / ENHANCED OBD II / ACTIVE TEST / A/F CONTROL / USER DATA / AFS B1S1 and O2S B1S2, and press the YES button and then the ENTER button followed by the F4 button.

HINT:

- DTC P2A00 may be set, when the air-fuel ratio is stuck rich or lean.
- A low A/F sensor voltage could be caused by a rich air-fuel mixture. Check for conditions that would cause the engine to run rich.
- A high A/F sensor voltage could be caused by a lean air-fuel mixture. Check for conditions that would cause the engine to run lean.
- Read freeze frame data using an intelligent tester. Freeze frame data record the engine condition when malfunctions are detected. When troubleshooting, freeze frame data can help determine if the vehicle was moving or stationary, if the engine was warmed up or not, if the air-fuel ratio was lean or rich, and other data, from the time the malfunction occurred.
- DTC P2A00 may also be set, when the sensor element is electrically clogged or contaminated.

ES

1 CHECK ANY OTHER DTCS OUTPUT (IN ADDITION TO DTC P2A00)

- Connect an intelligent tester to the DLC3.
- Turn the ignition switch to ON.
- Turn the tester ON.
- Select the following menu items: DIAGNOSIS / ENHANCED OBD II / DTC INFO / CURRENT CODES.
- Read DTCs.

Result

Display (DTC Output)	Proceed To
P2A00	A
P2A00 and other DTCs	B

If any DTCs relating to the A/F sensor (DTCs for the A/F sensor heater or A/F sensor admittance) are output, troubleshoot those DTCs first.

B **GO TO DTC CHART**

A

2 INSPECT AIR FUEL RATIO SENSOR (HEATER RESISTANCE)

Component Side:

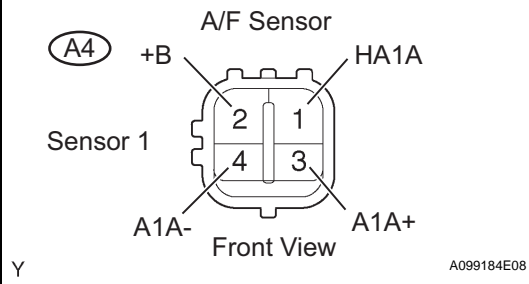

- (a) Disconnect the A4 Air-Fuel Ratio (A/F) sensor connector.
- (b) Measure the resistance between the terminals of the A/F sensor connector.

Standard Resistance

Tester Connections	Specified Conditions
HA1A (1) - +B (2)	1.8 to 3.4 Ω at 20°C (68°F)
HA1A (1) - A1A- (4)	10 kΩ or higher

- (c) Reconnect the air-fuel ratio sensor connector.

NG → **REPLACE AIR FUEL RATIO SENSOR**

OK

ES

3 CHECK HARNESS AND CONNECTOR (ECM - AIR FUEL RATIO SENSOR)

Wire Harness Side:

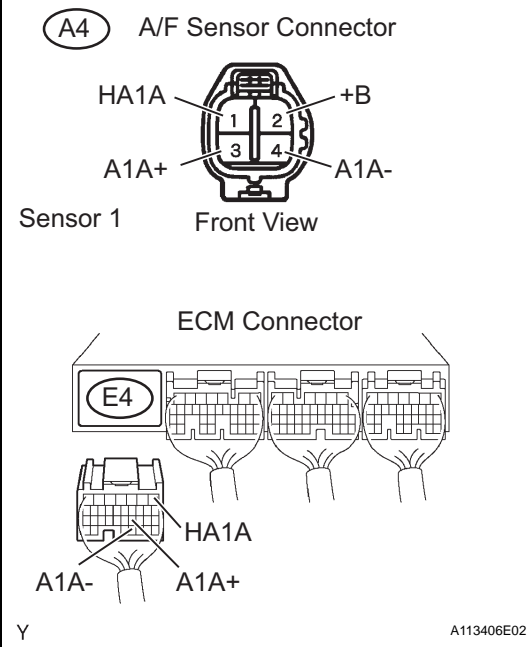

- (a) Disconnect the A4 A/F sensor connector.
- (b) Turn the ignition switch to ON.
- (c) Measure the voltage between the +B terminal of the A/F sensor connector and body ground.

Standard Voltage

Tester Connections	Specified Conditions
+B (A4-2) - Body ground	9 to 14 V

- (d) Turn the ignition switch to OFF.
- (e) Disconnect the E4 ECM connector.
- (f) Check the resistance.

Standard Resistance (Check for open)

Tester Connections	Specified Conditions
HA1A (A4-1) - HA1A (E4-1)	Below 1 Ω
A1A+ (A4-3) - A1A+ (E4-21)	Below 1 Ω
A1A- (A4-4) - A1A- (E4-31)	Below 1 Ω

Standard Resistance (Check for short)

Tester Connections	Specified Conditions
HA1A (A4-1) or HA1A (E4-1) - Body ground	10 kΩ or higher
A1A+ (A4-3) or A1A+ (E4-21) - Body ground	10 kΩ or higher
A1A- (A4-4) or A1A- (E4-31) - Body ground	10 kΩ or higher

- (g) Reconnect the ECM connector.
- (h) Reconnect the A/F sensor connector.

Reference (Bank 1 Sensor 1 System Diagram)

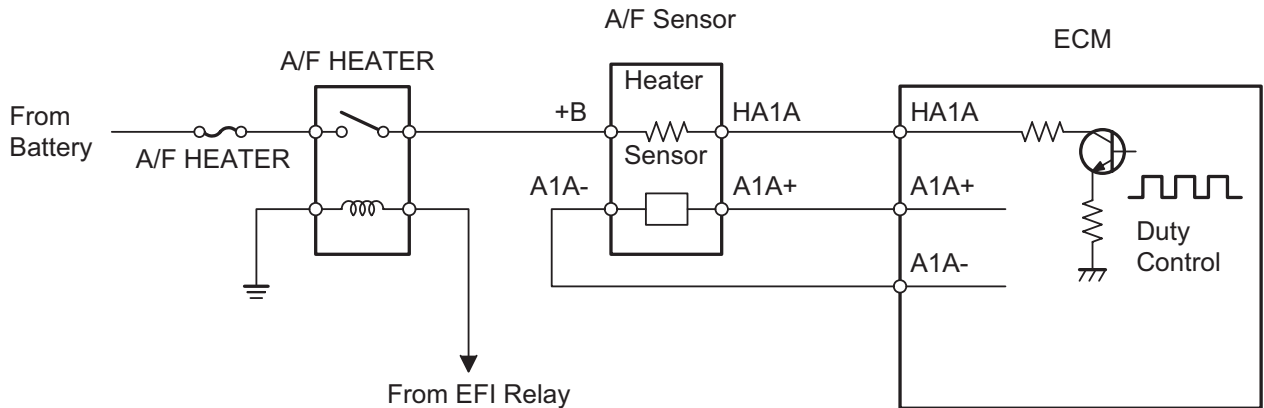

P

A118002E04

NG → **REPAIR OR REPLACE HARNESS OR CONNECTOR**

OK

4 **PERFORM CONFIRMATION DRIVING PATTERN**

NEXT

5 **CHECK WHETHER DTC OUTPUT RECURS (DTC P2A00)**

- (a) Connect the intelligent tester to the DLC3.
- (b) Turn the ignition switch to ON and turn the tester ON.
- (c) Select the following menu items: DIAGNOSIS / ENHANCED OBD II / DTC INFO / PENDING CODES.
- (d) Read pending DTCs.

Result

Display (DTC Output)	Proceed To
P2A00	A
No output	B

B → **CHECK FOR INTERMITTENT PROBLEMS**

A

ES

6 REPLACE AIR FUEL RATIO SENSOR

NEXT

7 PERFORM CONFIRMATION DRIVING PATTERN

NEXT

8 CHECK WHETHER DTC OUTPUT RECURS (DTC P2A00)

- (a) Connect the intelligent tester to the DLC3.
- (b) Turn the ignition switch to ON and turn the tester ON.
- (c) Select the following menu items: DIAGNOSIS / ENHANCED OBD II / DTC INFO / PENDING CODES.
- (d) Read pending DTCs.

ES

Result

Display (DTC Output)	Proceed To
No output	A
P2A00	B

B

CHECK EXTREMELY RICH OR LEAN ACTUAL AIR FUEL RATIO (REFER TO DTC P0171 PROCEDURE)

A

END