

## EVAP System

### RELATED DTCS

DTC No.	Monitoring Items	See procedure
P043E	Reference orifice clogged (built into canister pump module)	ES-213
P043F	Reference orifice high-flow (built into canister pump module)	
P0441	<ul style="list-style-type: none"> <li>Purge VSV (Vacuum Switching Valve) stuck closed</li> <li>Purge VSV stuck open</li> <li>Purge flow</li> </ul>	ES-220
P0450	Canister pressure sensor (built into canister pump module) voltage abnormal fluctuation	ES-228
P0451	<ul style="list-style-type: none"> <li>Canister pressure sensor (built into canister pump module) noise</li> <li>Canister pressure sensor stuck (built into canister pump module)</li> </ul>	
P0452	Canister pressure sensor (built into canister pump module) voltage low	
P0453	Canister pressure sensor (built into canister pump module) voltage high	
P0455	EVAP gross leak	
P0456	EVAP small leak	ES-237
P2401	Leak detection pump stuck OFF (built into canister pump module)	ES-334
P2402	Leak detection pump stuck ON (built into canister pump module)	
P2419	Vent valve stuck closed (built into canister pump module)	ES-341
P2420	Vent valve stuck open (vent) (built into canister pump module)	
P2610	Soak timer (built into ECM)	ES-380

If any EVAP system DTCs are set, the malfunctioning area can be determined using the table below.

Malfunctioning Areas	DTCs										
	P043E P043F	P0441	P0450	P0451	P0452	P0453	P0455	P0456	P2401 P2402	P2419	P2420
Reference orifice clogged	●								●	●	
Reference orifice high-flow	●								●	●	
Purge VSV stuck open		●					●				
Purge VSV stuck closed		●									
Canister pressure sensor stuck				●							
Canister pressure sensor noise				●							
Canister pressure sensor low output			●		●						
Canister pressure sensor high output			●			●					
Gross leak		●					●				
Small leak								●			
Leak detection pump stuck OFF	●								●	●	
Leak detection pump stuck ON	●								●	●	
Vent valve stuck closed	●								●	●	
Vent valve stuck open (vent)											●

ES

Y

A106731E06

**NOTICE:**

If the 0.02 inch leak criterion difference between the first and second checks is greater than the specification, the DTCs corresponding to the leak criterion (P043E, P043F, P2401, P2402 and P2419) will be all stored.

DESCRIPTION

Location of EVAP (Evaporative Emission) System:

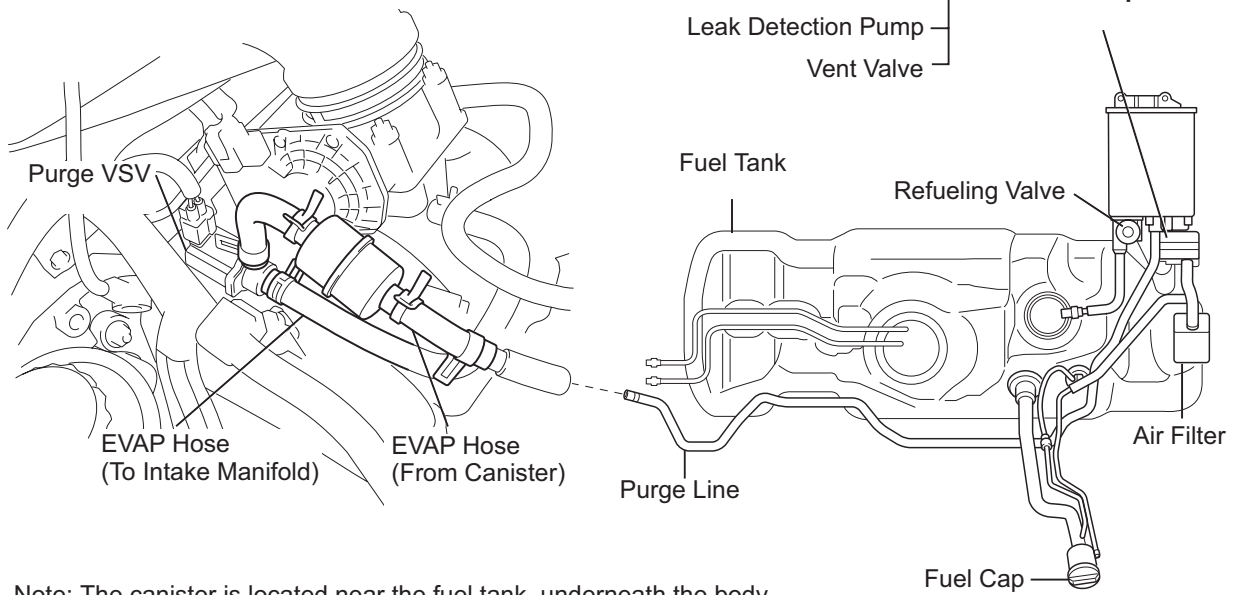

Note: The canister is located near the fuel tank, underneath the body

A121764E01

EVAP System Circuit:

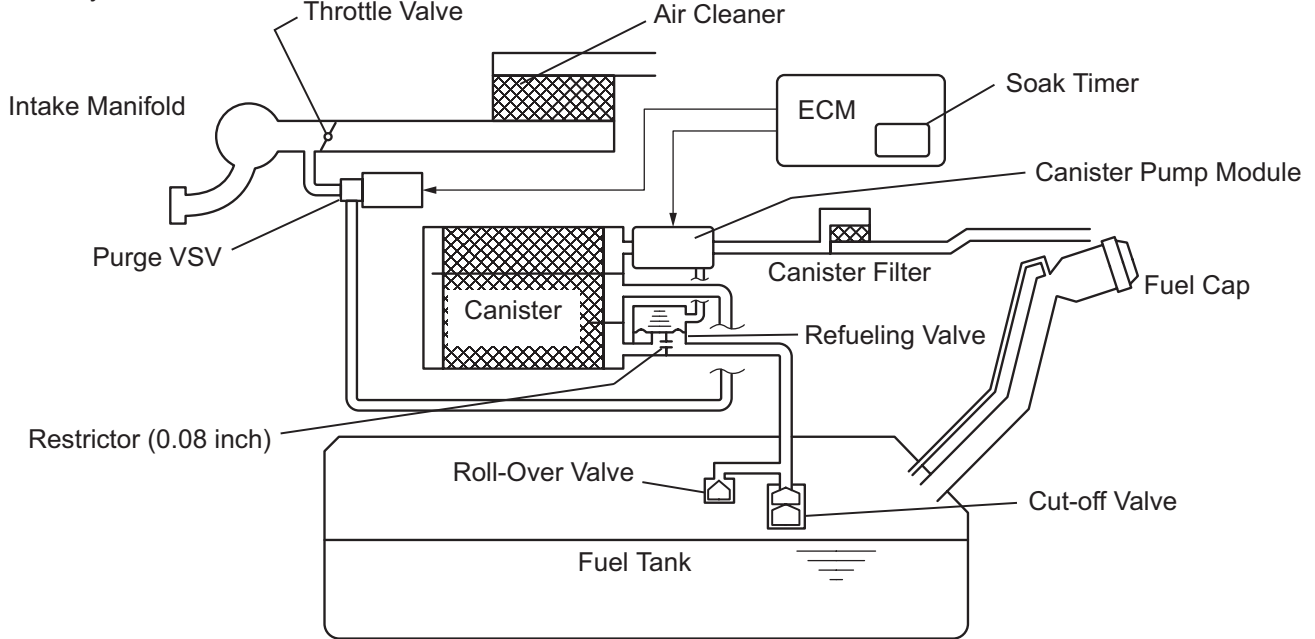

A122570E01

NOTICE:

In this vehicle's EVAP system, turning ON the vent valve does not seal off the EVAP system. To check for leaks in the EVAP system, disconnect the air inlet vent hose and apply pressure from the atmosphere side of the canister.

ES

While the engine is running, if a predetermined condition (closed-loop etc.) is met, the purge VSV is opened by the ECM and stored fuel vapors in the canister are purged to the intake manifold. The ECM changes the duty cycle ratio of the purge VSV to control purge flow volume.

The purge flow volume is also determined by the intake manifold pressure. Atmospheric pressure is allowed into the canister through the vent valve to ensure that the purge flow is maintained when the negative pressure (vacuum) is applied to the canister.

The following two monitors run to confirm appropriate EVAP system operation.

### 1. Key-off monitor

This monitor checks for EVAP (Evaporative Emission) system leaks and canister pump module malfunctions. The monitor starts 5 hours\* after the ignition switch is turned to OFF. More than 5 hours are required to allow enough time for the fuel to cool down to stabilize the Fuel Tank Pressure (FTP), thus making the EVAP system monitor more accurate.

The leak detection pump creates negative pressure (vacuum) in the EVAP system and the pressure is measured. Finally, the ECM monitors for leaks from the EVAP system, and malfunctions in both the canister pump module and purge VSV, based on the EVAP pressure.

HINT:

\*: If the engine coolant temperature is not below 35°C 5 hours after the ignition switch is turned off, the monitor check starts 2 hours later. If it is still not below 35°C 7 hours after the ignition switch is turned off, the monitor check starts 2.5 hours later.

### 2. Purge flow monitor

The purge flow monitor consists of the two monitors. The 1st monitor is always conducted every time and the 2nd monitor is activated if necessary.

- The 1st monitor

While the engine is running and the purge VSV (Vacuum Switching Valve) is ON (open), the ECM monitors the purge flow by measuring the EVAP pressure change. If negative pressure is not created, the ECM begins the 2nd monitor.

- The 2nd monitor

The vent valve is turned OFF (open) and the EVAP pressure is then measured. If the variation in the pressure is less than 0.5 kPa (3.75 mmHg), the ECM interprets this as the purge VSV being stuck closed, and illuminates the MIL and sets DTC P0441 (2 trip detection logic).

Atmospheric pressure check:

In order to ensure reliable malfunction detection, the variation between the atmospheric pressures, before and after conduction of the purge flow monitor, is measured by the ECM.

EVAP Purge Flow:

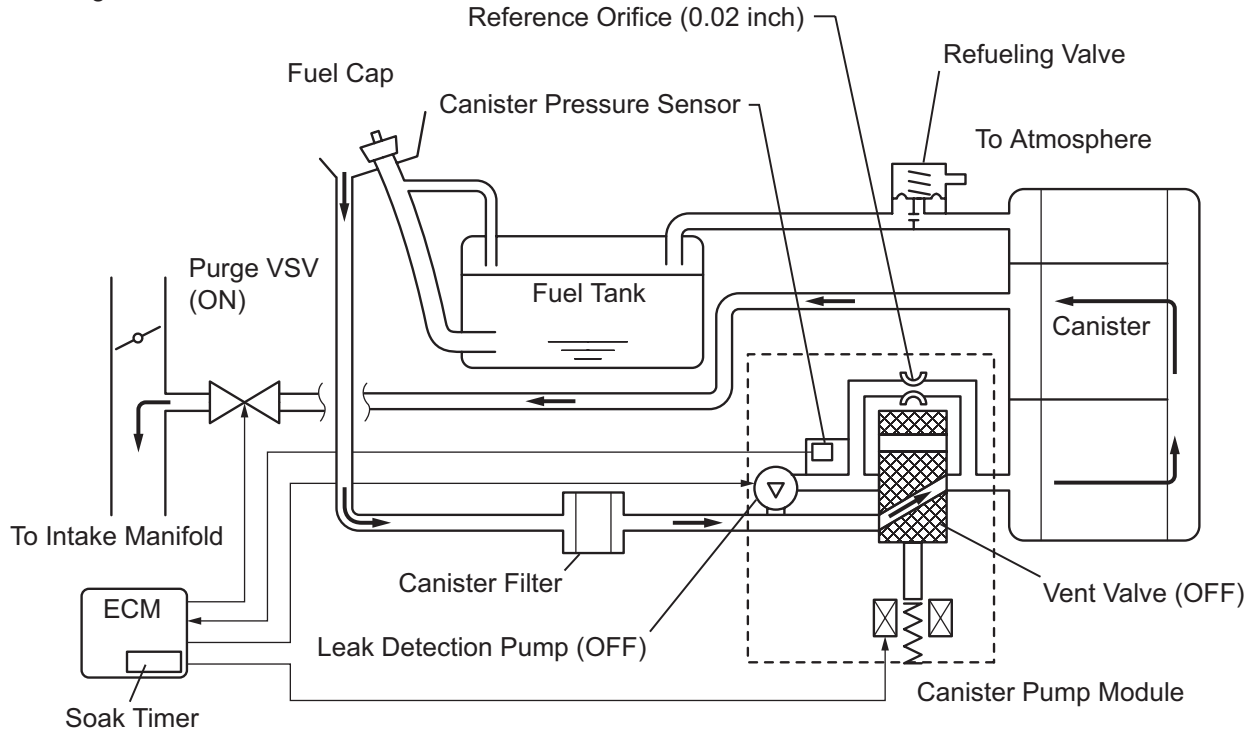

Y

A122571E01

Components	Operations
Canister	Contains activated charcoal to absorb EVAP (Evaporative Emissions) generated in fuel tank.
Cut-off valve	Located in fuel tank. Valve floats and closes when fuel tank 100 % full.
Purge VSV (Vacuum Switching Valve)	Opens or closes line between canister and intake manifold. ECM uses purge VSV to control EVAP purge flow. In order to discharge EVAP absorbed by canister to intake manifold, ECM opens purge VSV. EVAP discharge volume to intake manifold controlled by purge VSV duty cycle ratio (current-carrying time). (Open: ON, Close: OFF)
Refueling valve	Controls EVAP pressure from fuel tank to canister. Valve consists of diaphragm, spring and restrictor (diameter: 0.08 inch). When fuel vapor and pressure inside fuel tank increase, valve opens. While EVAP purged, valve closes and restrictor prevents large amount of vacuum from affecting pressure in fuel tank. Valve opened while refueling. When valve open, adding fuel into fuel tank possible.
Roll-over valve	Located in fuel tank. Valve closes by its own weight when vehicle overturns to prevent fuel from spilling out.
Soak timer	Built into ECM. To ensure accurate EVAP monitor, measures 5 hours (+- 15 min) after ignition switch turned to OFF. This allows fuel to cool down, stabilizing Fuel Tank Pressure (FTP). When approximately 5 hours elapsed, ECM activates.
Canister pump module	Consists of (a) to (d) below. Canister pump module cannot be disassembled.
(a) Vent valve	Vents and closes EVAP system. When ECM turns valve ON, EVAP system closed. When, ECM turns valve OFF, EVAP system vented. Negative pressure (vacuum) created in EVAP system to check for EVAP leaks by closing purge VSV, turning on vent valve (closed) and operating leak detection pump (refer to fig. 1).
(b) Canister pressure sensor	Indicates pressure as voltages. ECM supplies regulated 5 V to canister pressure sensor, and uses feedback from sensor to monitor EVAP system pressure (refer to fig 2).

ES

Components	Operations
(c) Leak detection pump	Creates negative pressure (vacuum) in EVAP system for leak check.
(d) Reference orifice	Has opening with 0.02 inch diameter. Vacuum produced through orifice by closing purge VSV, turning off vent valve and operating leak detection pump, to monitor 0.02 inch leak criterion. 0.02 inch leak criterion indicates small leak of EVAP.

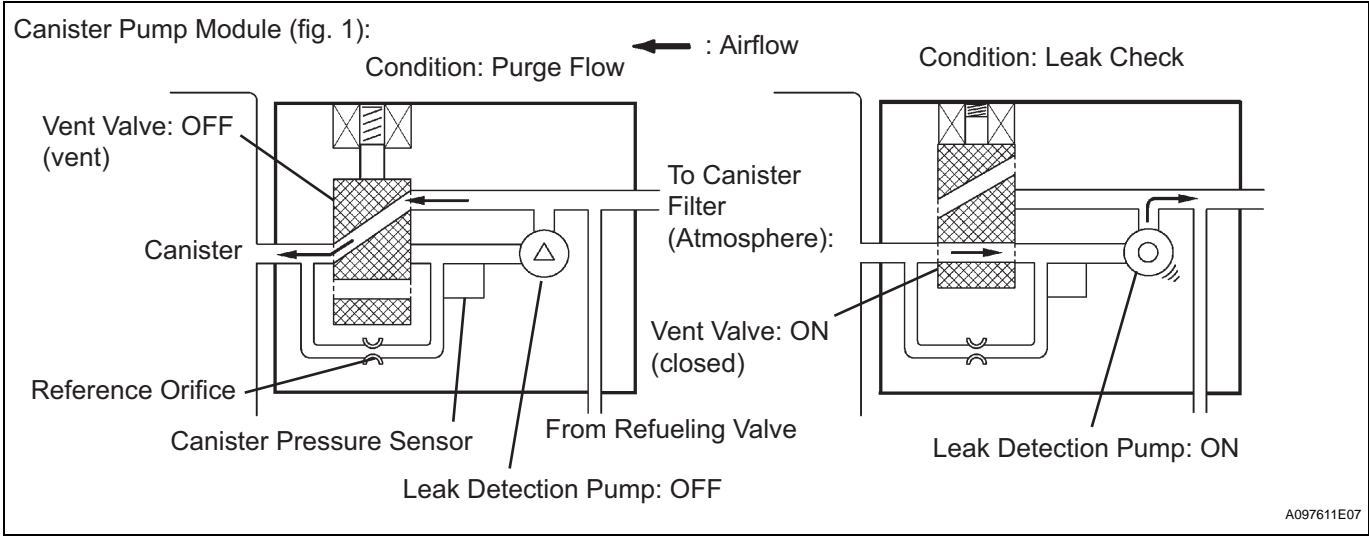

ES

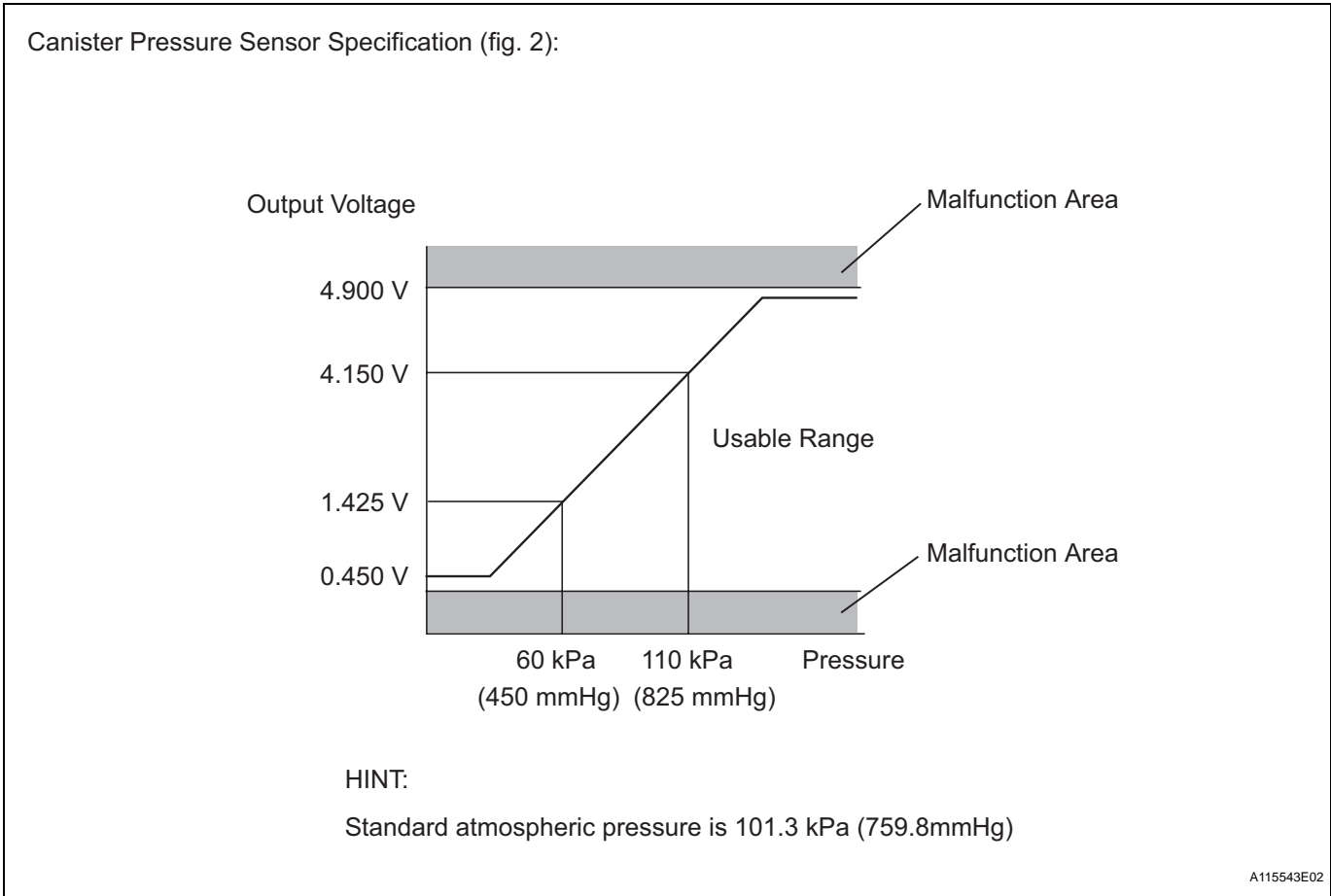

Soak Timer Circuit (fig. 3):

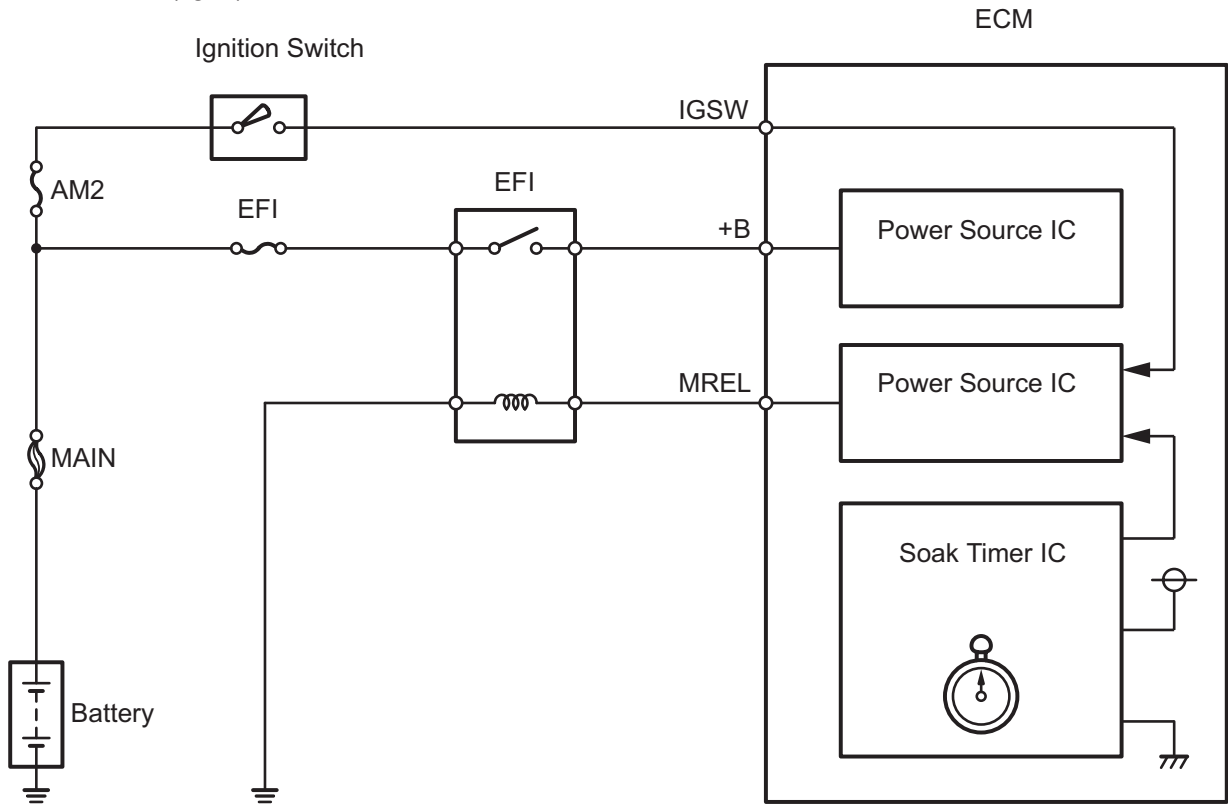

ES

**WIRING DIAGRAM**

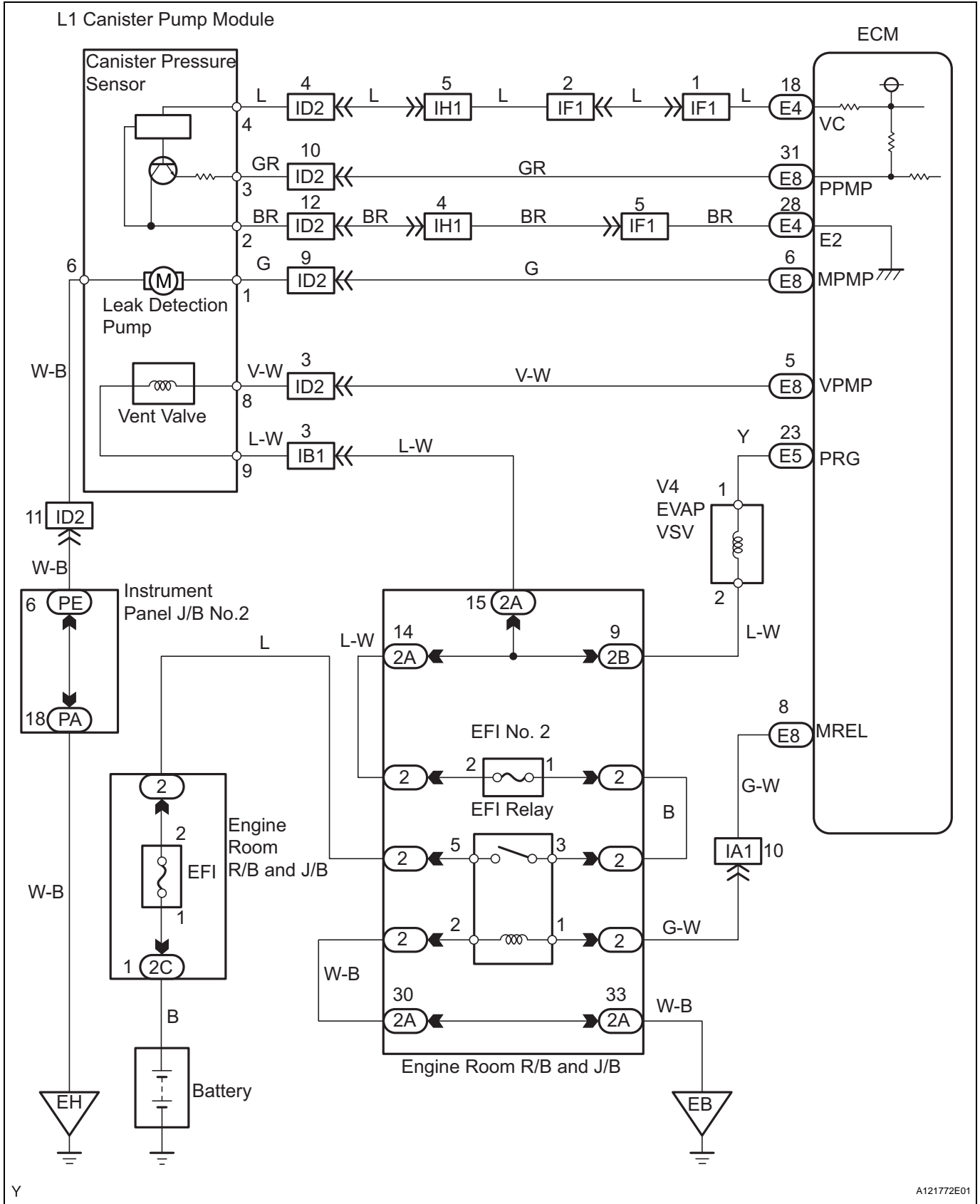

**ES**

**NOTICE:**

The intelligent tester is required to conduct the following diagnostic troubleshooting procedure.



## HINT:

- Using intelligent tester monitor results enables the EVAP (Evaporative Emission) system to be confirmed.
- Read freeze frame data using an intelligent tester. Freeze frame data record the engine condition when malfunctions are detected. When troubleshooting, freeze frame data can help determine if the vehicle was moving or stationary, if the engine was warmed up or not, if the air-fuel ratio was lean or rich, and other data, from the time the malfunction occurred.

**1****CONFIRM DTC**

- Turn the ignition switch to OFF and wait for 10 seconds.
- Turn the ignition switch to ON.
- Turn the ignition switch to OFF and wait for 10 seconds.
- Connect an intelligent tester to the DLC3.
- Turn the ignition switch to ON and turn the tester ON.
- Select the following menu items: DIAGNOSIS / ENHANCED OBD II / DTC INFO / CURRENT CODES.
- Confirm DTCs and freeze frame data.

If any EVAP system DTCs are set, the malfunctioning area can be determined using the table below.

**NOTICE:**

**If the 0.02 inch leak criterion difference between the first and second checks is greater than the specification, the DTCs corresponding to the leak criterion (P043E, P043F, P2401, P2402 and P2419) will all be stored.**

Malfunctioning Areas	DTCs	P043E P043F	P0441	P0450	P0451	P0452	P0453	P0455	P0456	P2401 P2402	P2419	P2420
	Reference orifice clogged		●								●	●
Reference orifice high-flow		●								●	●	
Purge VSV stuck open			●					●				
Purge VSV stuck closed			●									
Canister pressure sensor stuck					●							
Canister pressure sensor noise					●							
Canister pressure sensor low output				●		●						
Canister pressure sensor high output				●			●					
Gross leak			●					●				
Small leak									●			
Leak detection pump stuck OFF		●								●	●	
Leak detection pump stuck ON		●								●	●	
Vent valve stuck closed		●								●	●	
Vent valve stuck open (vent)												●

Y

A106731E06

**NEXT**

**2 PERFORM EVAP SYSTEM CHECK (AUTO OPERATION)**

**NOTICE:**

- The EVAP SYSTEM CHECK (AUTO OPERATION) consists of five steps performed automatically by the intelligent tester. It takes a maximum of approximately 18 minutes.
- Do not perform the EVAP SYSTEM CHECK when the fuel tank is more than 90 % full because the cut-off valve may be closed and making the leak check of the fuel tank unavailable.
- Do not run the engine in this step.
- When the temperature of the fuel is 35°C (95°F) or more, a large amount of vapor forms and any check results become inaccurate. When performing the EVAP SYSTEM CHECK, keep the temperature below 35°C (95°F).

(a) Clear DTCs (see page ES-40).

**ES**

- (b) On the tester, select the following menu items:  
DIAGNOSIS / ENHANCED OBD II / SYSTEM CHECK / EVAP SYS CHECK / AUTO OPERATION.
- (c) After the EVAP SYSTEM CHECK is completed, check for pending DTCs by selecting the following menu items:  
DIAGNOSIS / ENHANCED OBD II / DTC INFO / PENDING CODES.

HINT:

If no pending DTC is displayed, perform the Monitor Confirmation (see "Diagnostic Help" menu). After this confirmation, check for pending DTCs. If no DTC is displayed, the EVAP system is normal.

NEXT

ES

**3 PERFORM EVAP SYSTEM CHECK (MANUAL OPERATION)**

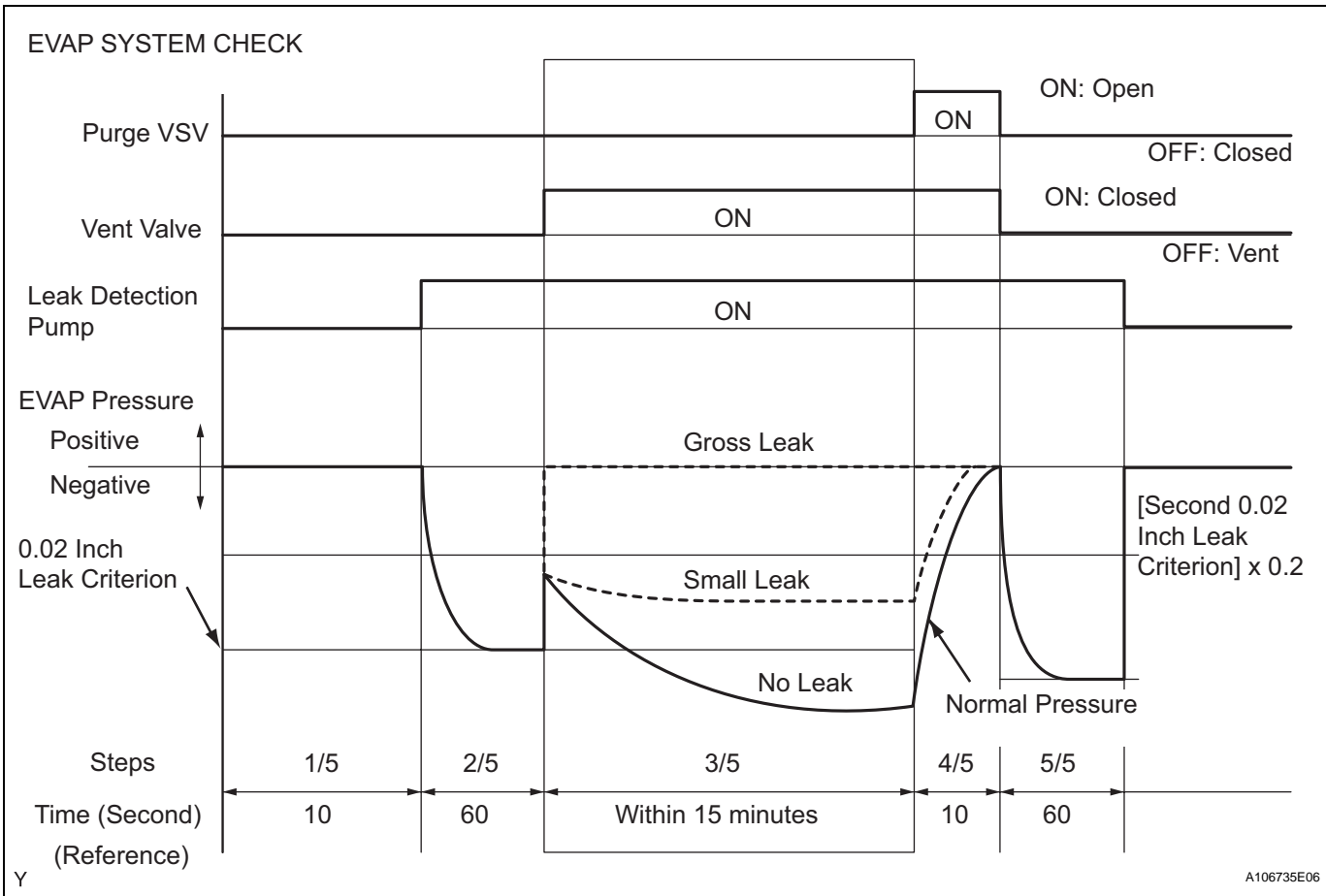

**NOTICE:**

- In the EVAP SYSTEM CHECK (MANUAL OPERATION), the series of 5 EVAP SYSTEM CHECK steps is performed manually by the intelligent tester.
- Do not perform the EVAP SYSTEM CHECK when the fuel tank is more than 90 % full because the cut-off valve may be closed and making the leak check of the fuel tank unavailable.
- Do not run the engine in this step.

- When the temperature of the fuel is 35°C (95°F) or more, a large amount of vapor forms and any check results become inaccurate. When performing the **EVAP SYSTEM CHECK**, keep the temperature below 35°C (95°F).
- (a) Clear DTCs (see page [ES-40](#)).
- (b) Select the following menu items: DIAGNOSIS / ENHANCED OBD II / SYSTEM CHECK / EVAP SYS CHECK / MANUAL OPERATION.

**NEXT**

**4 PERFORM EVAP SYSTEM CHECK (STEP 1/5)**

**ES**

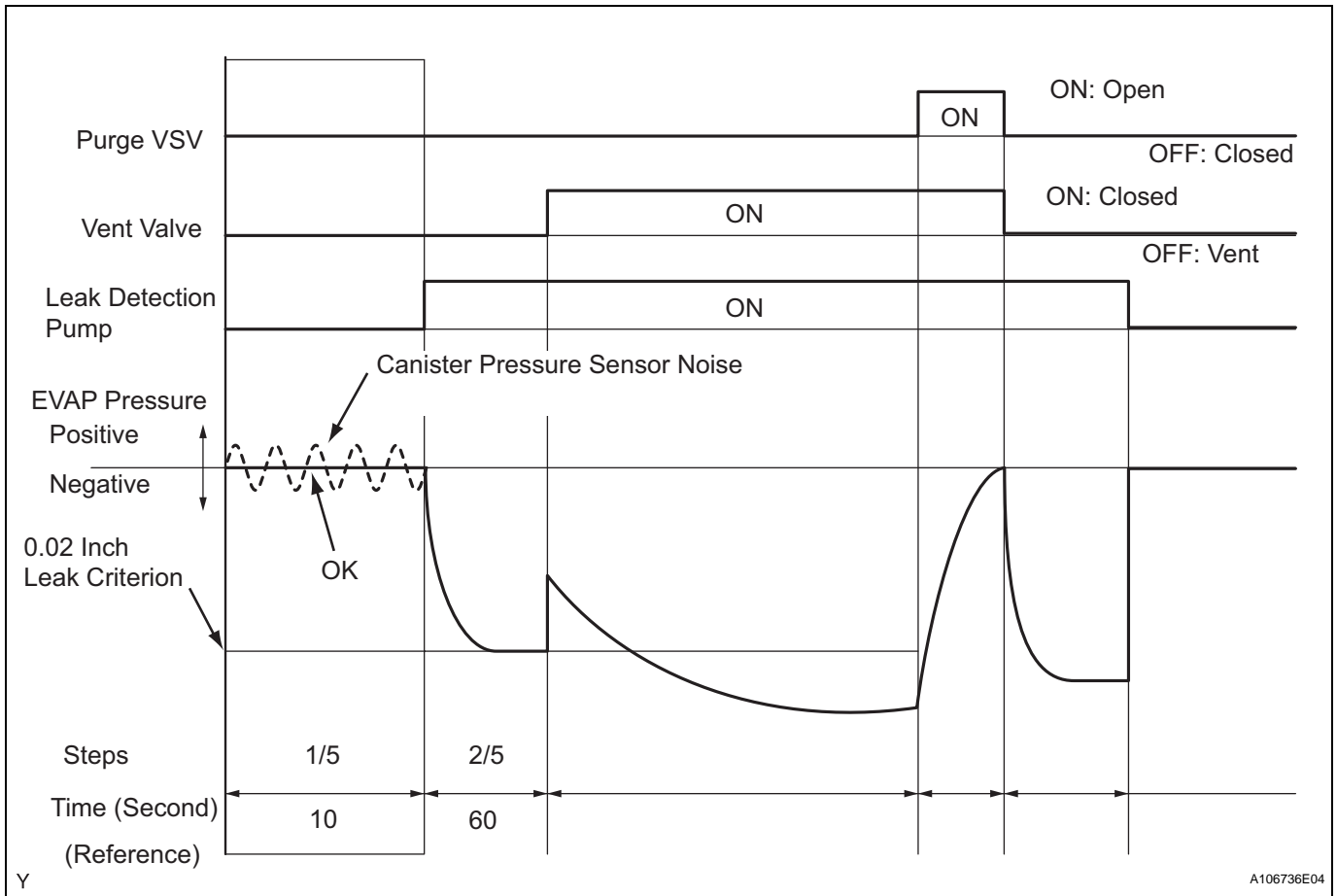

(a) Check the EVAP pressure in step 1/5.

**Result**

DTCs *	Test Results	Suspected Trouble Areas	Proceed To
-	Virtually no variation in EVAP pressure	Not yet determined	A
P0451	EVAP pressure fluctuates by +- 0.3 kPa (2.25 mmHg) or more	Canister pressure sensor noise	B

\*: These DTCs are already present in the ECM when the vehicle arrives and are confirmed in step 1.

**B**

**Go to step 30**

A

**5 PERFORM EVAP SYSTEM CHECK (STEP 1/5 TO 2/5)**

ES

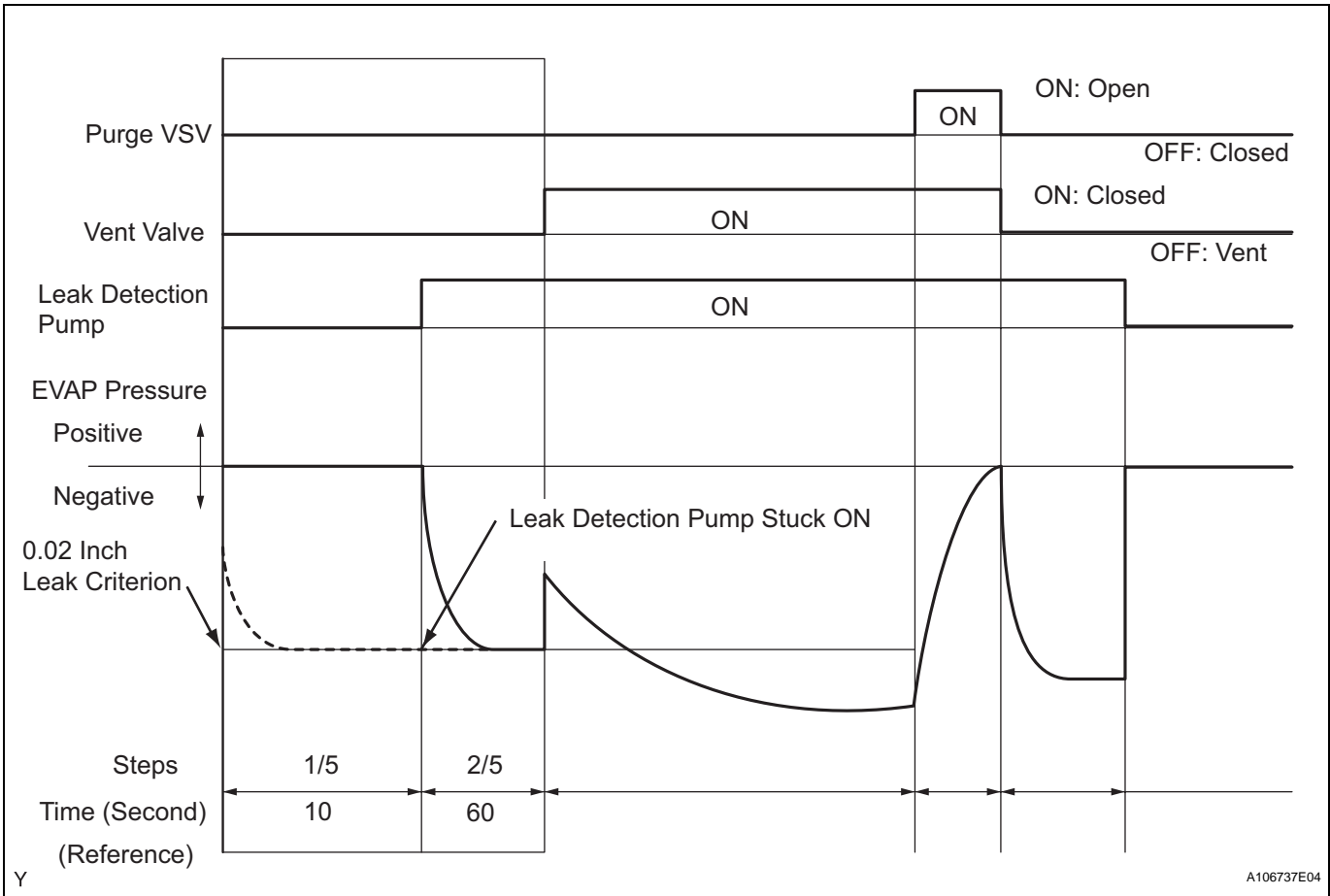

(a) Check the EVAP pressure in step 1/5 and 2/5.

**Result**

DTCs*	Test Results	Suspected Trouble Areas	Proceed To
-	Virtually no variation in EVAP pressure during step 1/5. Then decreases to 0.02 inch leak criterion	Not yet determined	A
P2402	Small difference between EVAP pressures during steps 1/5 and 2/5	Leak detection pump stuck ON	B

\*: These DTCs are already present in the ECM when the vehicle arrives and are confirmed in step 1.

HINT:

The first 0.02 inch leak criterion is the value determined in step 2/5.

B

**Go to step 23**

A

**6 PERFORM EVAP SYSTEM CHECK (STEP 2/5)**

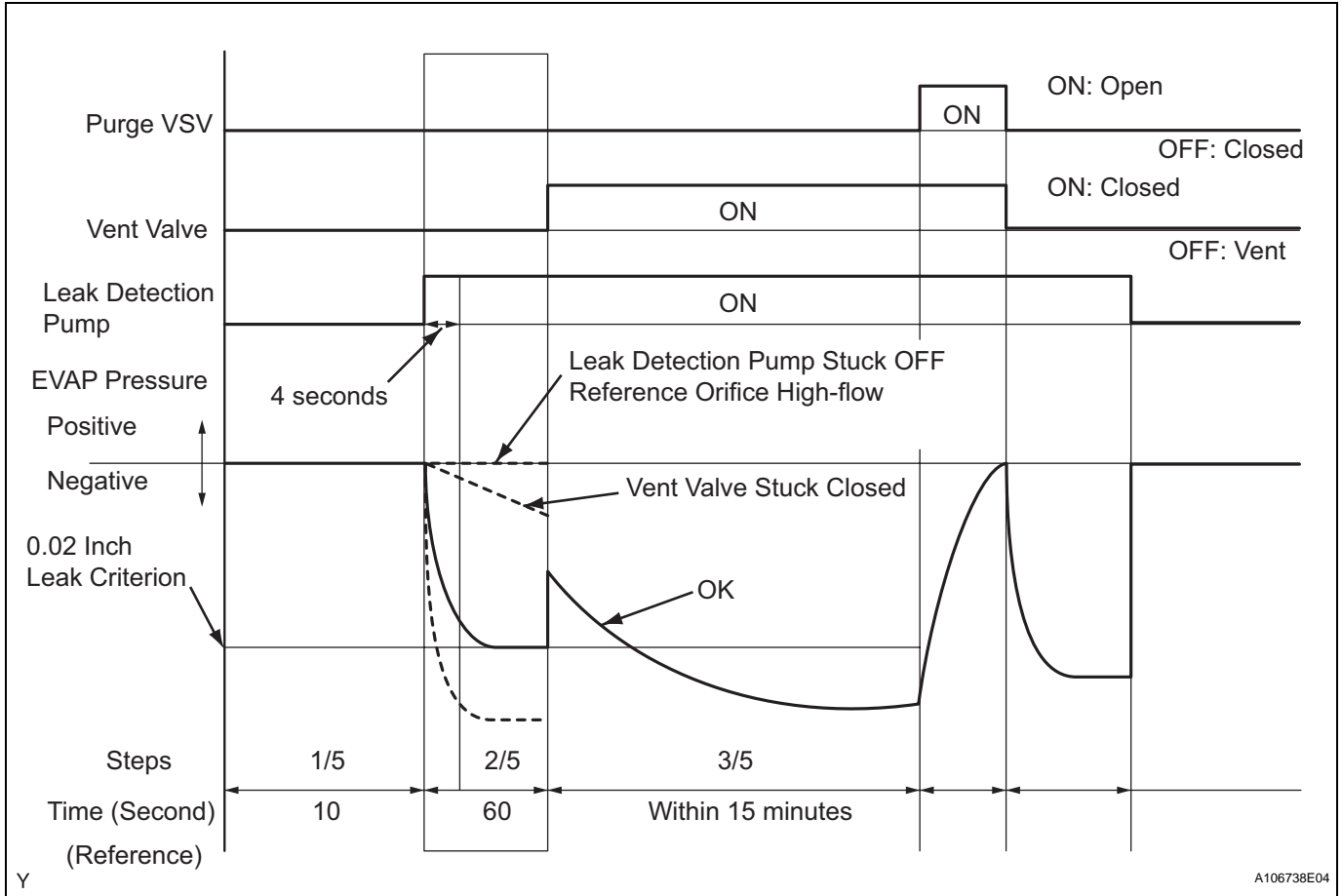

**ES**

**HINT:**

Make a note of the pressures checked in steps (a) and (b) below.

- (a) Check the EVAP pressure 4 seconds after the leak detection pump is activated\*.
- (b) Check the EVAP pressure again when it has stabilized. This pressure is the 0.02 inch leak criterion.

\*: The leak detection pump begins to operate as step 1/5 is proceeded to step 2/5.

**Result**

DTCs*	Test Results	Suspected Trouble Areas	Proceed To
-	EVAP pressure in step (b) between -4.85 kPa and -1.06 kPa (-36.38 mmHg and -7.95 mmHg)	Not yet determined	A
P043F and P2401	EVAP pressure in step (b) -1.06 kPa (-7.95 mmHg) or more	<ul style="list-style-type: none"> <li>• Reference orifice high-flow</li> <li>• Leak detection pump stuck OFF</li> </ul>	B
P043E	EVAP pressure in step (b) below -4.85 kPa (-36.38 mmHg)	Reference orifice clogged	C
P2419	EVAP pressure in step (a) more than -1.06 kPa (-7.95 mmHg)	Vent valve stuck closed	D

\*: These DTCs are already present in the ECM when the vehicle arrives and are confirmed in step 1.

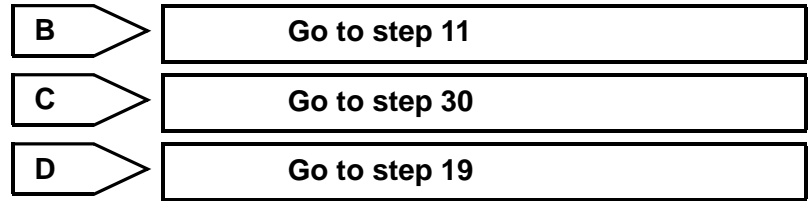

**7 PERFORM EVAP SYSTEM CHECK (STEP 2/5 TO 3/5)**

**ES**

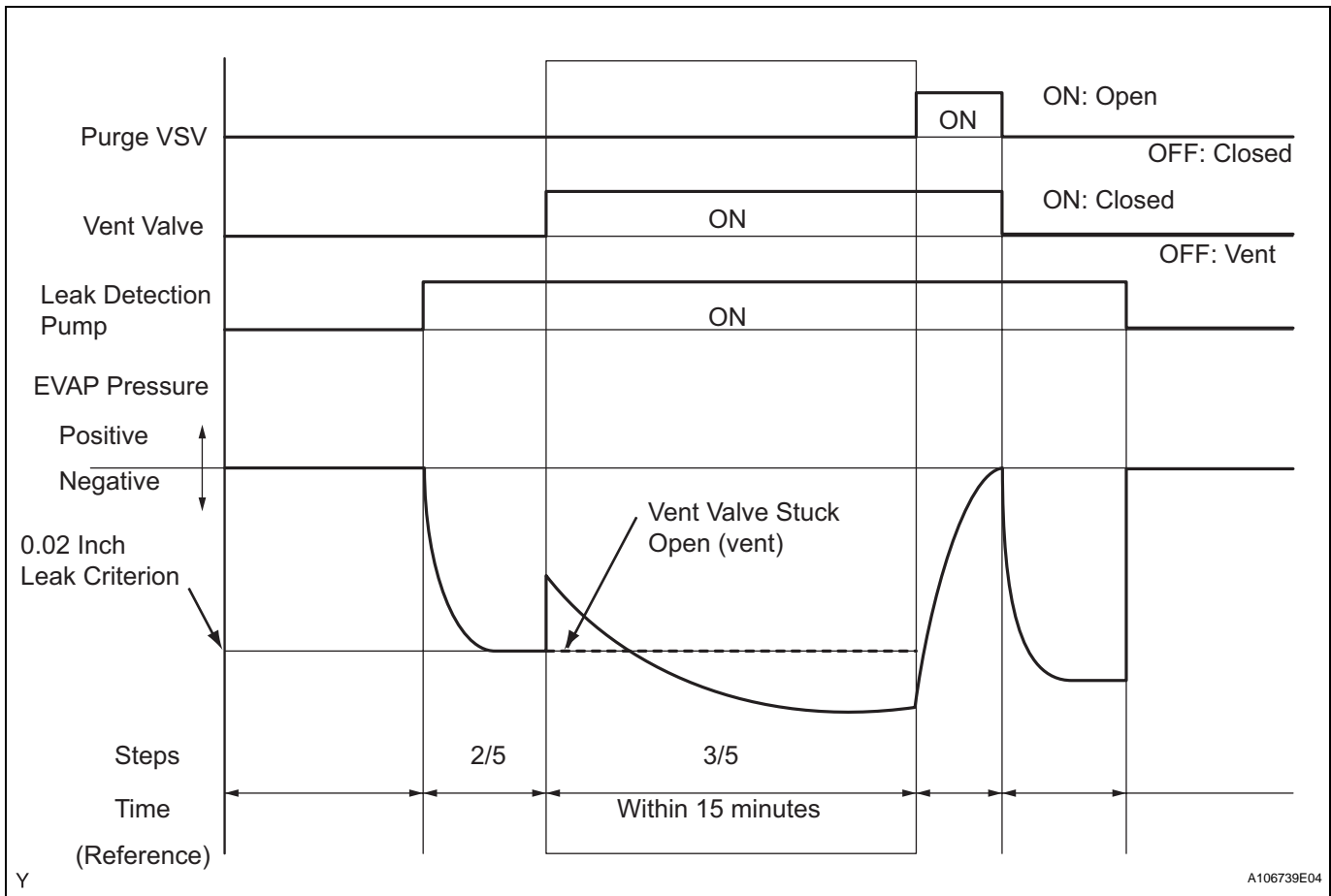

(a) Check the EVAP pressure increase in step 3/5.

**Result**

DTCs*	Test Results	Suspected Trouble Areas	Proceed To
-	EVAP pressure increases by 0.3 kPa (2.25 mmHg) or more within 10 seconds of proceeding from step 2/5 to step 3/5	Not yet determined	A
P2420	No variation in EVAP pressure despite proceeding from step 2/5 to step 3/5	Vent valve stuck open (vent)	B
P0451	No variation in EVAP pressure during steps 1/5 through 3/5	Canister pressure sensor malfunction stuck	C

\*: These DTCs are already present in the ECM when the vehicle arrives and are confirmed in step 1.

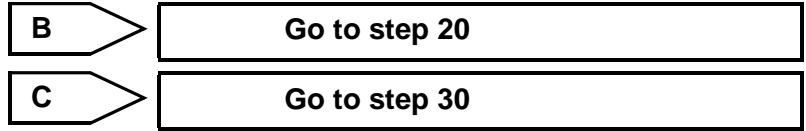

**8 PERFORM EVAP SYSTEM CHECK (STEP 3/5)**

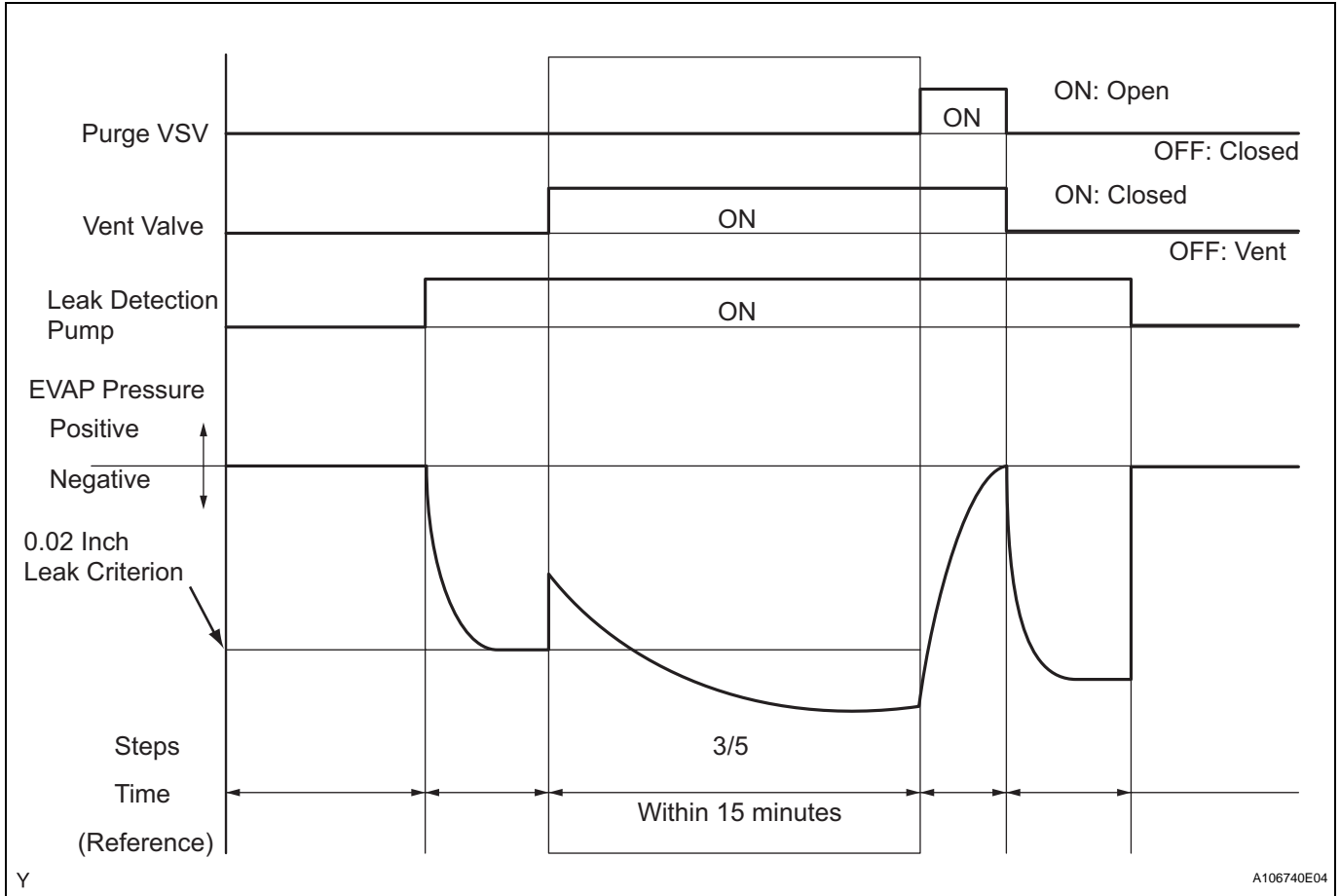

ES

- (a) Wait until the EVAP pressure change is less than 0.1 kPa (0.75 mmHg) for 30 seconds.
  - (b) Measure the EVAP pressure and record it.
- HINT:  
A few minutes are required for the EVAP pressure to become saturated. When there is little fuel in the fuel tank, it takes up to 15 minutes (900 seconds).





**9 PERFORM EVAP SYSTEM CHECK (STEP 4/5)**

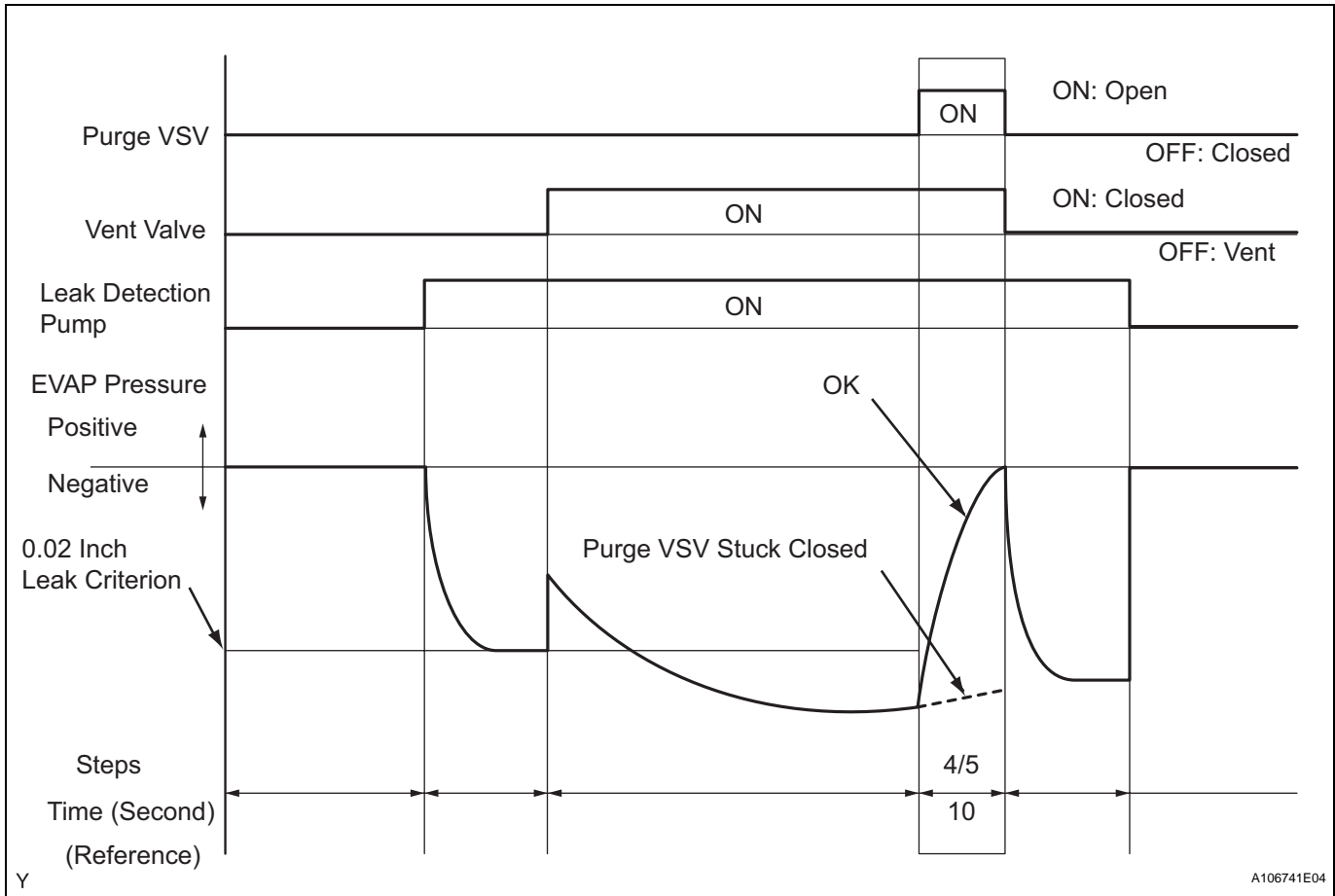

(a) Check the EVAP pressure in step 4/5.

**Result**

DTCs*	Test Results	Suspected Trouble Areas	Proceed To
-	EVAP pressure increases by 0.3 kPa (2.25 mmHg) or more within 10 seconds of proceeding from step 3/5 to step 4/5	Not yet determined	A
P0441	EVAP pressure increases by 0.3 kPa (2.25 mmHg) or more within 10 seconds of proceeding from step 3/5 to step 4/5	Problems in EVAP hose between pure VSV and intake manifold	B
P0441	Variation in EVAP pressure less than 0.3 kPa (2.25 mmHg) for 10 seconds, after proceeding from step 3/5 to step 4/5	Purge VSV stuck closed	C

\*: These DTCs are already present in the ECM when the vehicle arrives and are confirmed in step 1.

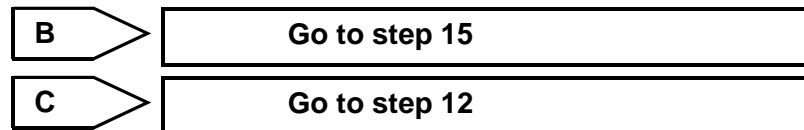

A

**10** PERFORM EVAP SYSTEM CHECK (STEP 5/5)

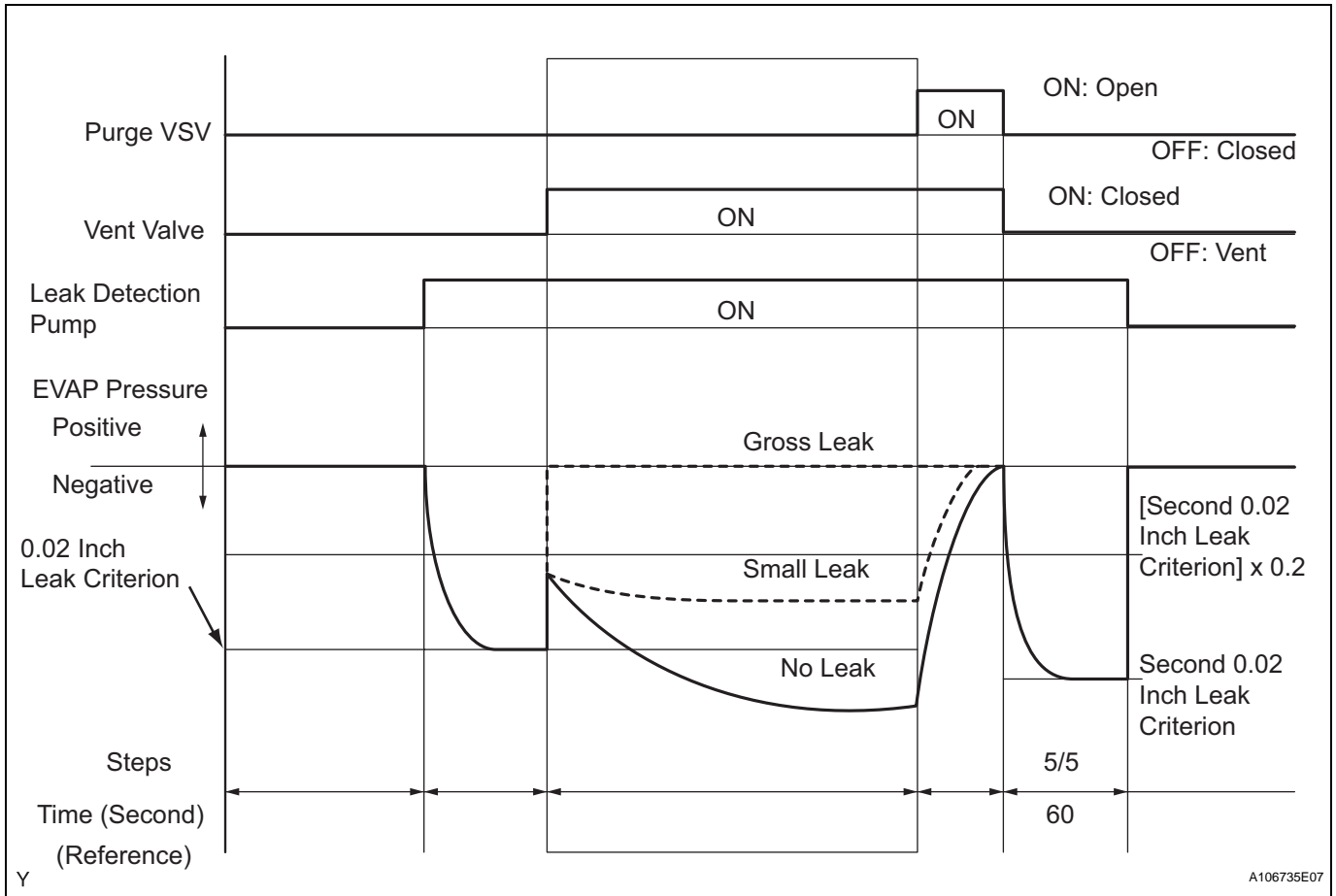

ES

- (a) Check the EVAP pressure in step 5/5.
- (b) Compare the EVAP pressure in step 3/5 and the second 0.02 inch leak criterion (step 5/5).

**Result**

DTCs*	Test Results	Suspected Trouble Areas	Proceed To
-	EVAP pressure (step 3/5) lower than second 0.02 inch leak criterion (step 5/5)	Not yet determined (no leakage from EVAP system)	A
P0441 and P0455	EVAP pressure (step 3/5) higher than [second 0.02 inch leak criterion (step 5/5) x 0.2]	<ul style="list-style-type: none"> <li>• Purge VSV stuck open</li> <li>• EVAP gross leak</li> </ul>	B
P0456	EVAP pressure (step 3/5) higher than second 0.02 inch leak criterion (step 5/5)	EVAP small leak	B

\*: These DTCs are already present in the ECM when the vehicle arrives and are confirmed in step 1.

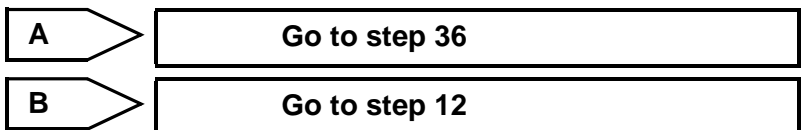

**11 PERFORM EVAP SYSTEM CHECK (STEP 3/5)**

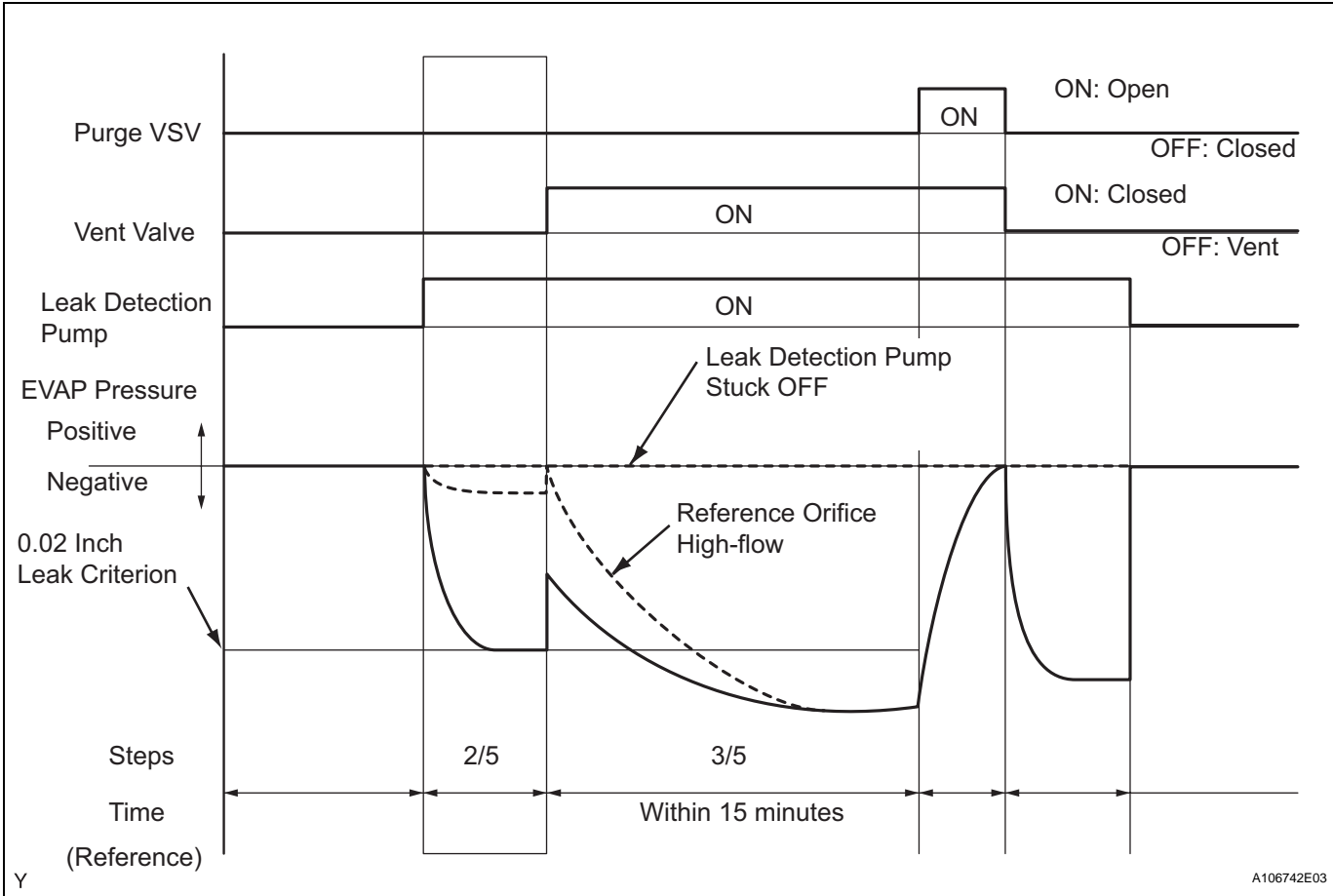

(a) Check the EVAP pressure in step 3/5.

**Result**

DTCs*	Test Results	Suspected Trouble Areas	Proceed To
P043F	EVAP pressure less than [0.02 inch leak criterion] measured at 2/5	Reference orifice high-flow	A
P2401	EVAP pressure almost same as [0.02 inch leak criterion] measured at 2/5	Leak detection pump stuck OFF	B

\*: These DTCs are already present in the ECM when the vehicle arrives and are confirmed in step 1.

HINT:

The first 0.02 inch leak criterion is the value determined in step 2/5.

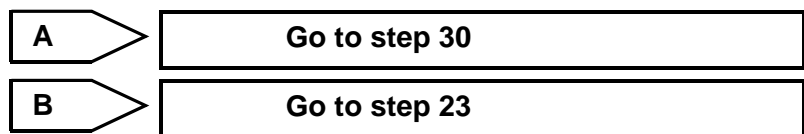

**12 PERFORM ACTIVE TEST USING INTELLIGENT TESTER (PURGE VSV)**

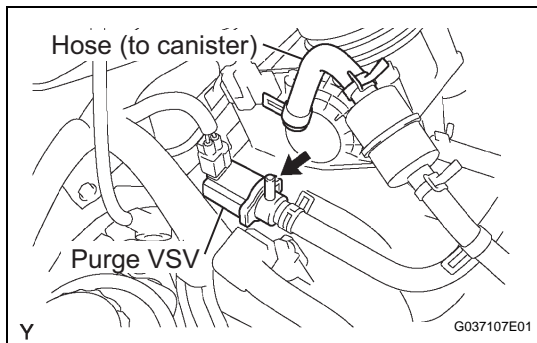

- (a) On the intelligent tester, select the following menu items: DIAGNOSIS / ENHANCED OBD II/ ACTIVE TEST / EVAP VSV.
- (b) Disconnect the hose (connected to the canister) from the purge VSV.
- (c) Start the engine.
- (d) Using the tester, turn off the purge VSV (EVAP VSV: OFF).
- (e) Use your finger to confirm that the purge VSV has no suction.
- (f) Using the tester, turn on the purge VSV (EVAP VSV: ON).
- (g) Use your finger to confirm that the purge VSV has suction.

**ES**

**Result**

Test Results	Suspected Trouble Areas	Proceed To
No suction when Purge VSV turned OFF, and suction applied when turned ON	Purge VSV normal	A
Suction applied when purge VSV turned OFF	Purge VSV stuck open	B
No suction when purge VSV turned ON	<ul style="list-style-type: none"> <li>• Purge VSV stuck closed</li> <li>• Problems with EVAP hose between purge VSV and intake manifold</li> </ul>	C

- (h) Reconnect the hose.

**B** → **Go to step 14**

**C** → **Go to step 15**

**A**

**13 CHECK FUEL CAP ASSEMBLY**

- (a) Check that the fuel cap is correctly installed.
- (b) Confirm that the fuel cap is tightened until a few click sounds are heard.  
 HINT:  
 If an EVAP tester is available, check the fuel cap using the tester.
  - (1) Remove the fuel cap and install it onto a fuel cap adaptor.
  - (2) Connect an EVAP tester pump hose to the adaptor, and pressurize the cap to 3.2 to 3.7 kPa (24 to 28 mmHg) using an EVAP tester pump.
  - (3) Seal the adaptor and wait for 2 minutes.
  - (4) Check the pressure. If the pressure is 2 kPa (15 mmHg) or more, the fuel cap is normal.
- (c) Reinstall the fuel cap.

**Result**

Test Results	Suspected Trouble Areas	Proceed To
Fuel cap correctly installed	-	A
Fuel cap loose	<ul style="list-style-type: none"> <li>• Fuel cap improperly installed</li> <li>• Defective fuel cap</li> <li>• Fuel cap does not meet OEM specifications</li> </ul>	B
No fuel cap	-	C

<b>A</b>	<b>Go to step 29</b>
<b>B</b>	<b>Go to step 27</b>
<b>C</b>	<b>Go to step 28</b>

**ES**

**14 INSPECT DUTY VACUUM SWITCHING VALVE (PURGE VSV)**

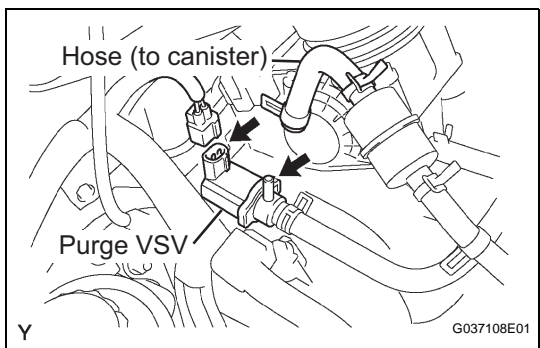

- (a) Turn the ignition switch to OFF.
- (b) Disconnect the V4 purge VSV connector.
- (c) Disconnect the hose (connected to the canister) from the purge VSV.
- (d) Start the engine.
- (e) Use your finger to confirm that the purge VSV has no suction.

**Result**

Test Results	Suspected Trouble Areas	Proceed To
No suction	ECM	A
Suction applied	Purge VSV	B

- (f) Reconnect the purge VSV connector.
- (g) Reconnect the hose.

<b>A</b>	<b>Go to step 35</b>
<b>B</b>	<b>Go to step 31</b>

**15 CHECK EVAP HOSE (PURGE VSV - INTAKE MANIFOLD)**

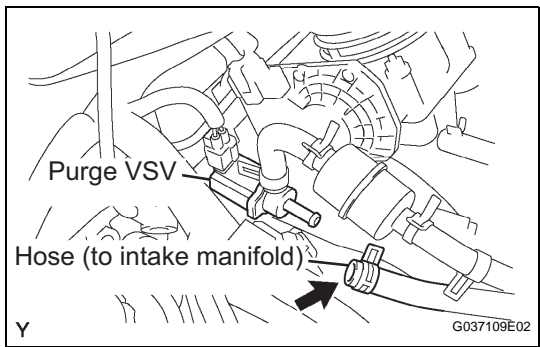

- (a) Disconnect the hose (connected to the intake manifold) from the purge VSV.
- (b) Start the engine.
- (c) Use your finger to confirm that the hose has suction.

**Result**

Test Results	Suspected Trouble Areas	Proceed To
Suction applied	EVAP hose between purge VSV and intake manifold normal	A
No suction	<ul style="list-style-type: none"> <li>Intake manifold port</li> <li>EVAP hose between purge VSV and intake manifold</li> </ul>	B

(d) Reconnect the hose.

**B** Go to step 26

**A**

**ES**

**16 INSPECT DUTY VACUUM SWITCHING VALVE (PURGE VSV)**

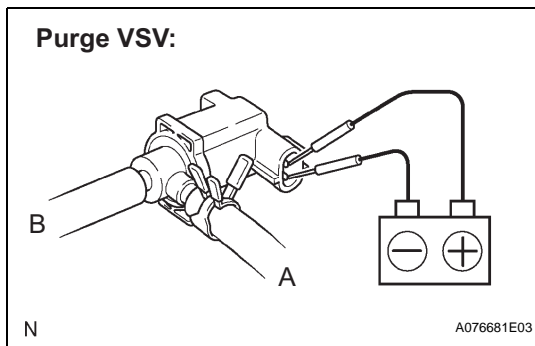

- (a) Remove the purge VSV.
- (b) Apply the battery voltage to the terminals of the purge VSV.
- (c) Using an air gun, confirm that air flows from port A to port B.

**Result**

Test Results	Suspected Trouble Areas	Proceed To
Air flows	Purge VSV normal	A
No air flow	Purge VSV	B

(d) Install the purge VSV.

**B** Go to step 31

**A**

**17 CHECK HARNESS AND CONNECTOR (POWER SOURCE OF PURGE VSV)**

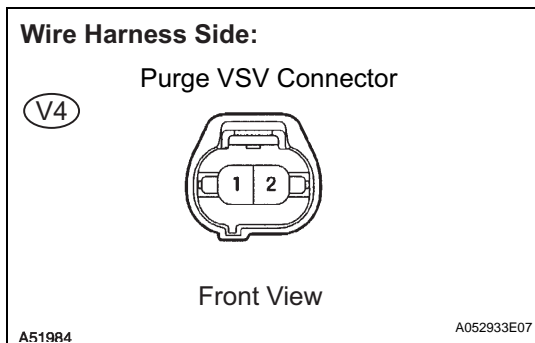

- (a) Disconnect the V4 purge VSV connector.
- (b) Turn the ignition switch to ON.
- (c) Measure the voltage between terminal 1 of the purge VSV connector and the body ground.

**Result**

Test Results	Suspected Trouble Areas	Proceed To
Between 11 V and 14 V	Normal	A

Test Results	Suspected Trouble Areas	Proceed To
Other than result above	Wire harness or connectors between purge VSV and ECM	B

(d) Reconnect the purge VSV connector.

**B** → **Go to step 32**

**A**

**18 CHECK HARNESS AND CONNECTOR (PURGE VSV - ECM)**

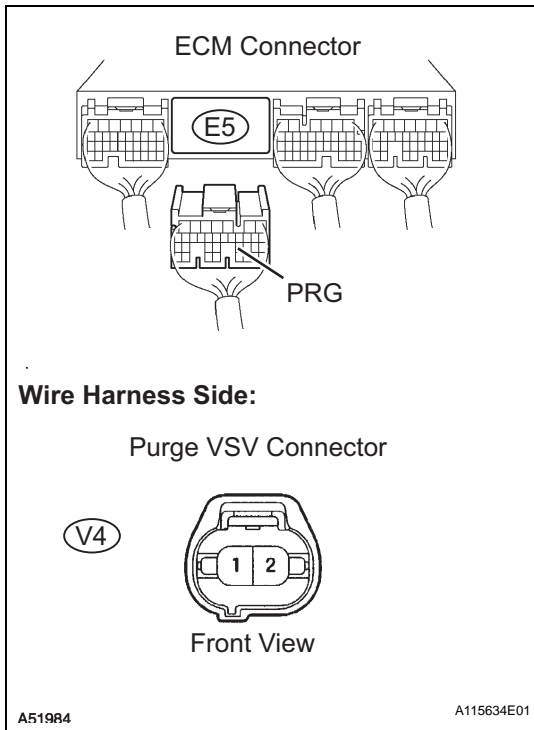

- (a) Disconnect the E5 ECM connector and the V4 purge VSV connector.
  - (b) Check the resistance.
- Standard Resistance**

Tester Connections	Specified Conditions
PRG (E5-23) - Purge VSV (V4-1)	Below 1 Ω
PRG (E5-23) - Body ground	10 kΩ or higher
Purge VSV (V4-2) - Body ground	10 kΩ or higher

- (c) Reconnect the purge VSV connector.
- (d) Reconnect the ECM connector.

**OK** → **Go to step 35**

**NG** → **Go to step 32**

**19 PERFORM ACTIVE TEST USING INTELLIGENT TESTER (FOR VENT VALVE)**

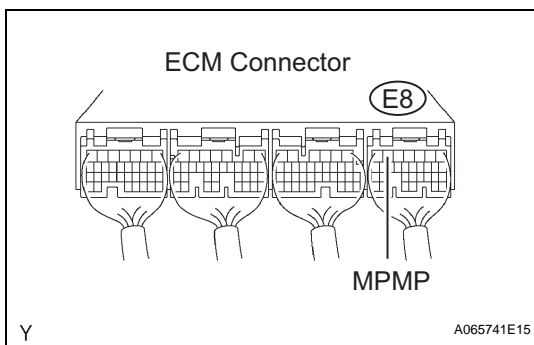

- (a) Turn the ignition switch to ON.
- (b) On the intelligent tester, select the following menu items: DIAGNOSIS / ENHANCED OBD II / ACTIVE TEST / VENT VALVE (ALONE).
- (c) Measure the voltage between terminal VPMP of the ECM connector and the body ground when the vent valve is turned ON (close) and OFF (vent) using the tester.

**Result**

Test Results	Suspected Trouble Areas	Proceed To
Between 9 V and 14 V when OFF Below 3 V when ON	Vent valve	A
Below 3 V when OFF and ON	ECM	B

- A** Go to step 22
- B** Go to step 35

**20** **PERFORM ACTIVE TEST USING INTELLIGENT TESTER (FOR VENT VALVE)**

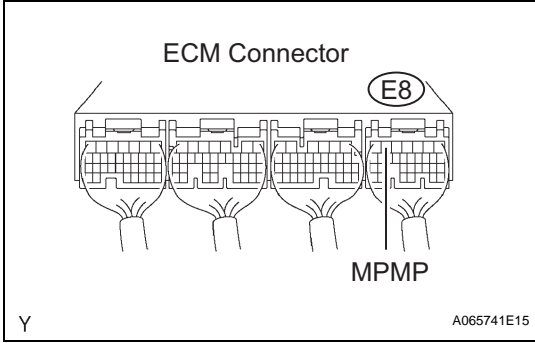

- (a) Turn the ignition switch to ON.
- (b) On the intelligent tester, select the following menu items: DIAGNOSIS / ENHANCED OBD II / ACTIVE TEST / VENT VALVE (ALONE).
- (c) Measure the voltage between terminal VPMP of the ECM connector and the body ground when the vent valve is turned ON (close) and OFF (vent) using the tester.

**ES**

**Result**

Test Results	Suspected Trouble Areas	Proceed To
Below 3 V when OFF and ON	Power source of vent valve	A
Between 9 V and 14 V when OFF Below 3 V when ON	Vent valve	B
Between 9 V and 14 V when OFF and ON	ECM	C

- B** Go to step 22
- C** Go to step 35

**A**



**21 INSPECT CANISTER PUMP MODULE (POWER SOURCE FOR VENT VALVE)**

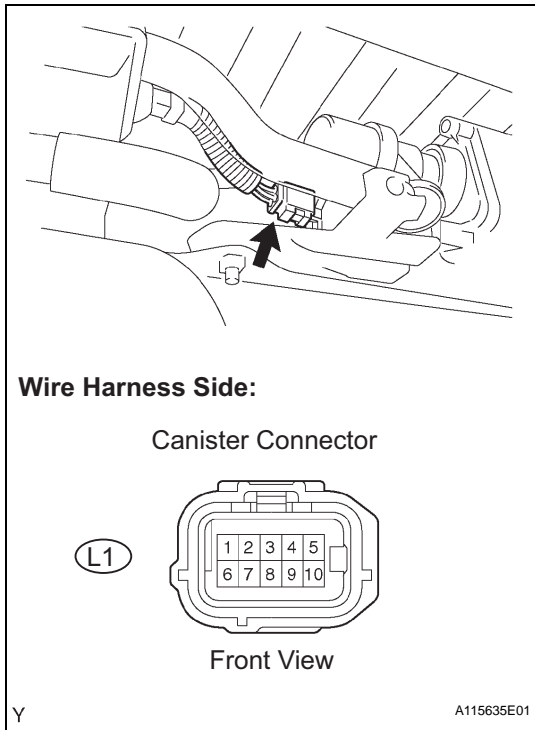

- (a) Turn the ignition switch OFF.
- (b) Disconnect the L1 canister connector.
- (c) Turn the ignition switch to ON.
- (d) Measure the voltage between terminal 9 of the canister connector and the body ground.

ES

**Result**

Test Results	Suspected Trouble Areas	Proceed To
Between 9 V and 14 V	Normal	A
Between 0 V and 3 V	Power source wire harness of vent valve	B

- (e) Reconnect the canister connector.

**B** → **Go to step 32**

**A**

**22 INSPECT CANISTER PUMP MODULE (VENT VALVE OPERATION)**

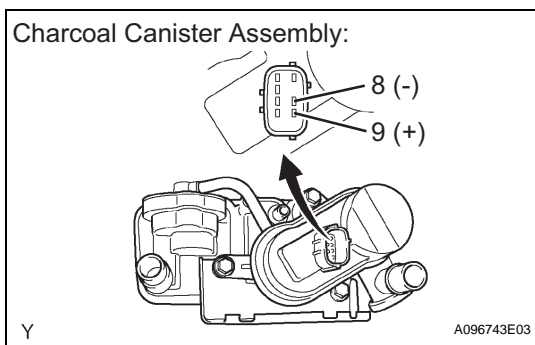

- (a) Turn the ignition switch to OFF.
- (b) Disconnect the L1 canister connector.
- (c) Apply the battery voltage to terminals 9 and 8 of the canister pump module.
- (d) Touch the canister pump module to confirm the vent valve operation.

**Result**

Test Results	Suspected Trouble Areas	Proceed To
Operating	Wire harness between vent valve and ECM	A
Not operating	Vent valve	B

(e) Reconnect the canister connector.

- A** Go to step 32
- B** Go to step 30

**23 PERFORM ACTIVE TEST USING INTELLIGENT TESTER (FOR CANISTER PUMP MODULE (LEAK DETECTION PUMP))**

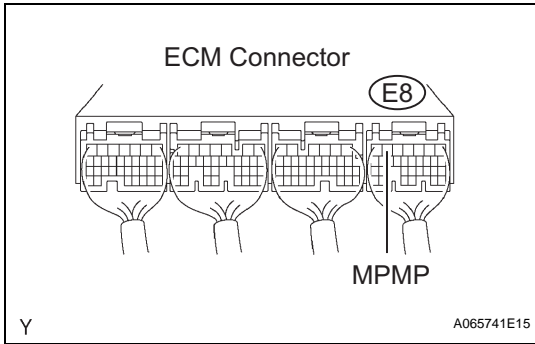

- (a) On the intelligent tester, select the following menu items: DIAGNOSIS / ENHANCED OBD II / ACTIVE TEST / VACUUM PUMP (ALONE).
- (b) Measure the voltage between MPMP terminal of the ECM connector and the body ground when the leak detection pump is turned ON and OFF using the tester.

**ES**

**Result**

Test Results	Suspected Trouble Areas	Proceed To
Between 0 V and 3 V when OFF Between 9 V and 14 V when ON	ECM normal	A
Between 9 V and 14 V when OFF Between 0 V and 3 V when ON	ECM	B

- B** Go to step 35

**A**

**24 CHECK HARNESS AND CONNECTOR (CANISTER PUMP MODULE - ECM)**

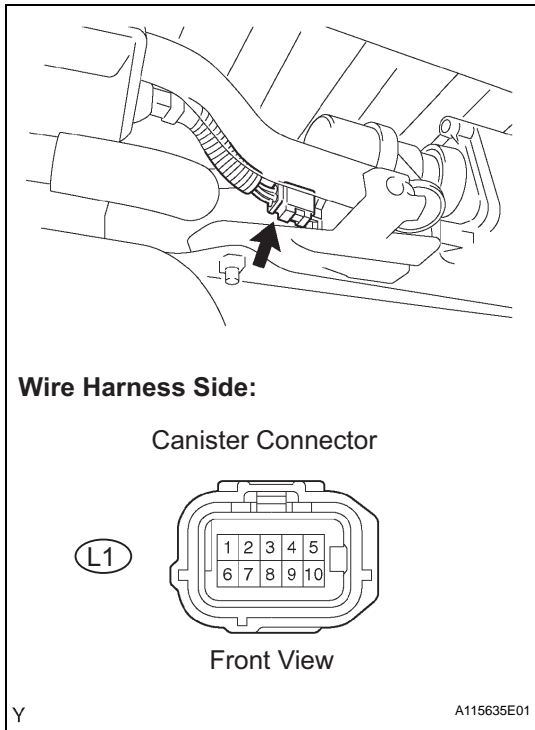

- (a) Turn the ignition switch to OFF.
- (b) Disconnect the L1 canister connector.
- (c) Turn the ignition switch to ON.
- (d) On the intelligent tester, select the following menu items: DIAGNOSIS / ENHANCED OBD II / ACTIVE TEST / VACUUM PUMP (ALONE).
- (e) Turn the leak detection pump ON.
- (f) Measure the voltage between terminal 1 of the canister connector and the body ground.

**ES**

**Result**

Test Results	Suspected Trouble Areas	Proceed To
Between 9 V and 14 V	Normal	A
Between 0 V and 3 V	Wire harness between ECM and leak detection pump	B

- (g) Reconnect the canister connector.

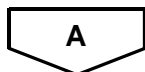

**25 CHECK HARNESS AND CONNECTOR (CANISTER PUMP MODULE - GROUND)**

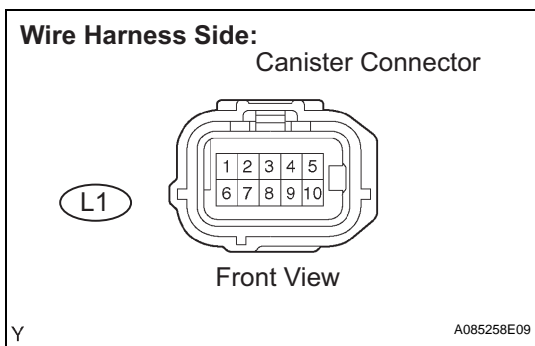

- (a) Disconnect the L1 canister connector.
- (b) Turn the ignition switch to OFF.
- (c) Check the resistance between terminal 6 of the canister connector and the body ground.

**Result**

Test Results	Suspected Trouble Areas	Proceed To
Below 1 Ω	Leak detection pump	A

Test Results	Suspected Trouble Areas	Proceed To
10 k $\Omega$ or higher	Wire harness between leak detection pump and body ground	B

(d) Reconnect the canister connector.



## 26 INSPECT INTAKE MANIFOLD (EVAP PURGE PORT)

- (a) Stop the engine.  
 (b) Disconnect the EVAP hose from the intake manifold.  
 (c) Start the engine.  
 (d) Use your finger to confirm that the port of the intake manifold has suction.

### Result

Test Results	Suspected Trouble Areas	Proceed To
Suction applied	EVAP hose between intake manifold and purge VSV	A
No suction	Intake manifold	B

(e) Reconnect the EVAP hose.



## 27 CORRECTLY REINSTALL OR REPLACE FUEL CAP

### HINT:

- When reinstalling the fuel cap, tighten it until a few click sounds are heard.
- When replacing the fuel cap, use a fuel cap that meets OEM specifications, and install it until a few click sounds are heard.



## 28 REPLACE FUEL CAP ASSEMBLY

### HINT:

When installing the fuel cap, tighten it until a few click sounds are heard.



## 29 REPAIR EVAP LEAKING PART

- (a) Reinstall the fuel cap.  
 (b) Disconnect the vent hose.

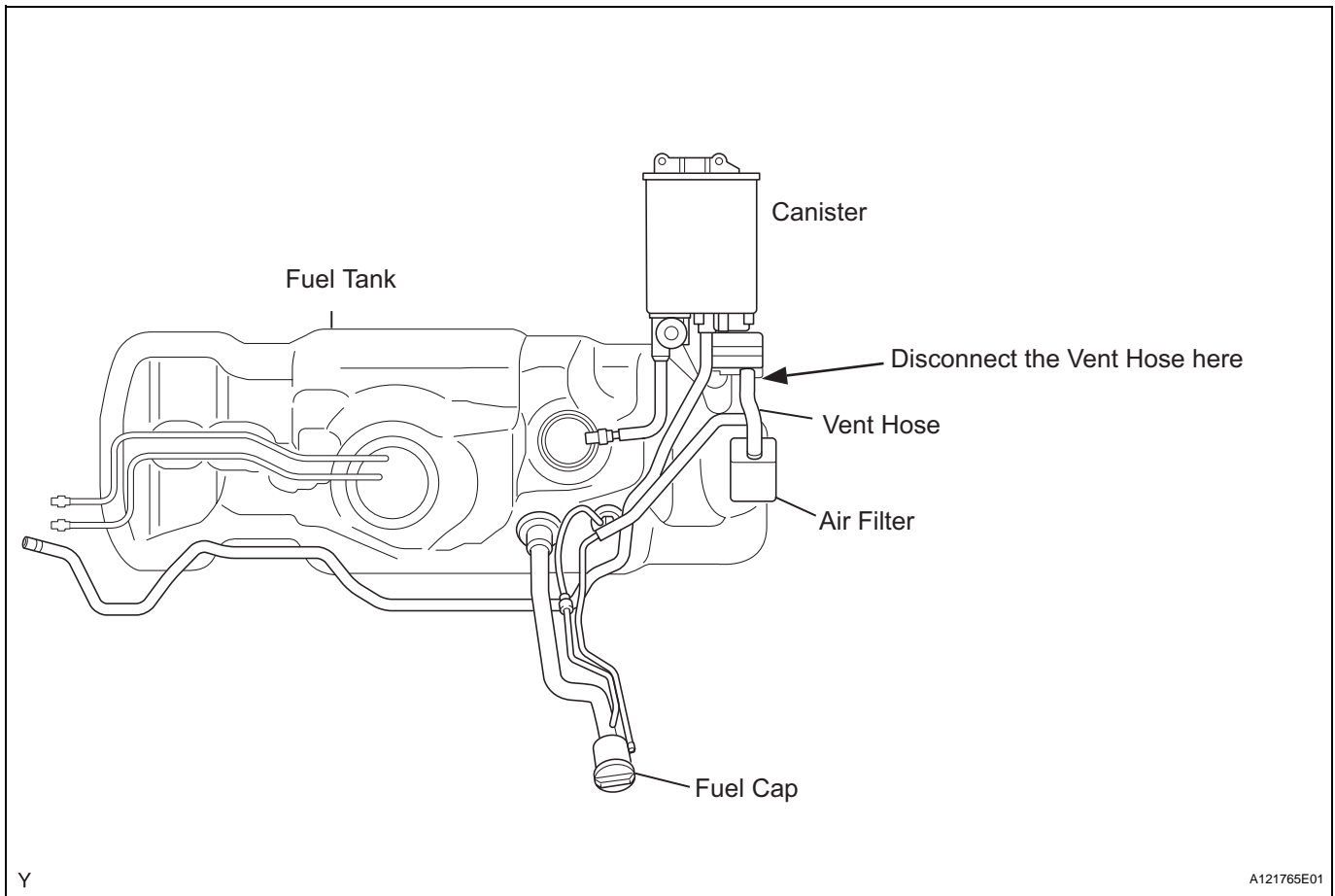

- (c) Connect the EVAP pressure tester tool to the canister with the adapter.

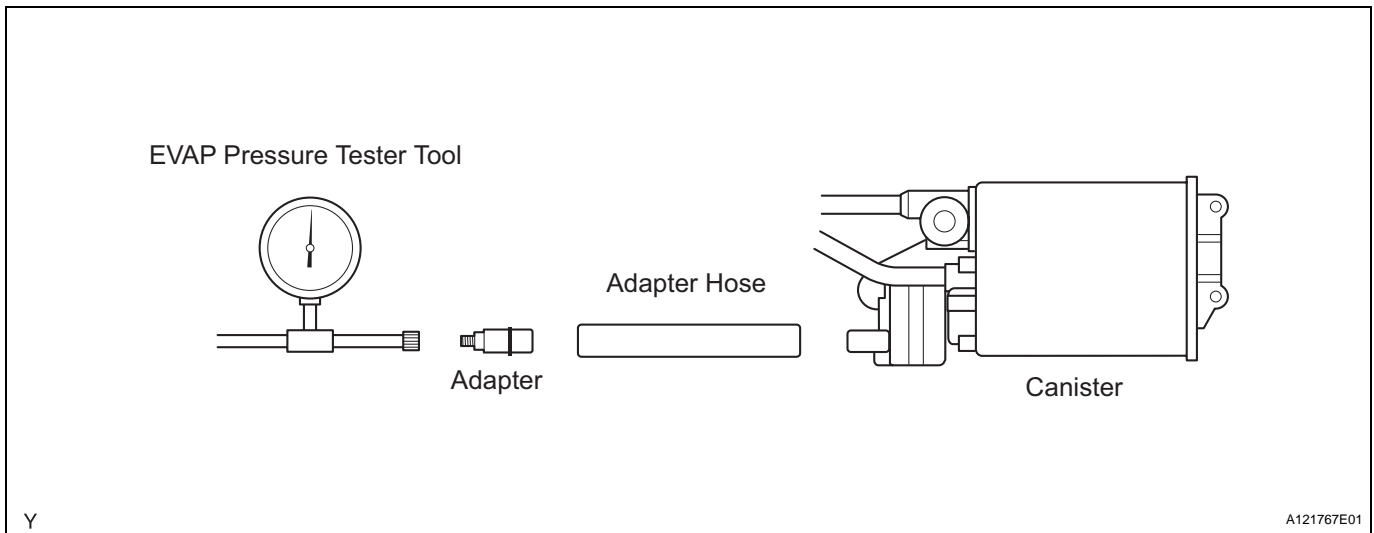

- (d) Pressurize the EVAP system to 3.2 to 3.7 kPa (24 to 28 mmHg).
- (e) Apply soapy water to the piping and connecting parts of the EVAP system.
- (f) Look for areas where bubbles appear. This indicates leak point.
- (g) Repair or replace the leak point.

**HINT:**

Disconnect the hose between the canister and the fuel tank from the canister. Block the canister side and conduct an inspection. In this way, the fuel tank can be excluded as an area suspected of causing fuel leaks.

**NEXT** **Go to step 37****30****REPLACE CHARCOAL CANISTER ASSEMBLY**

(a) Replace the canister assembly.

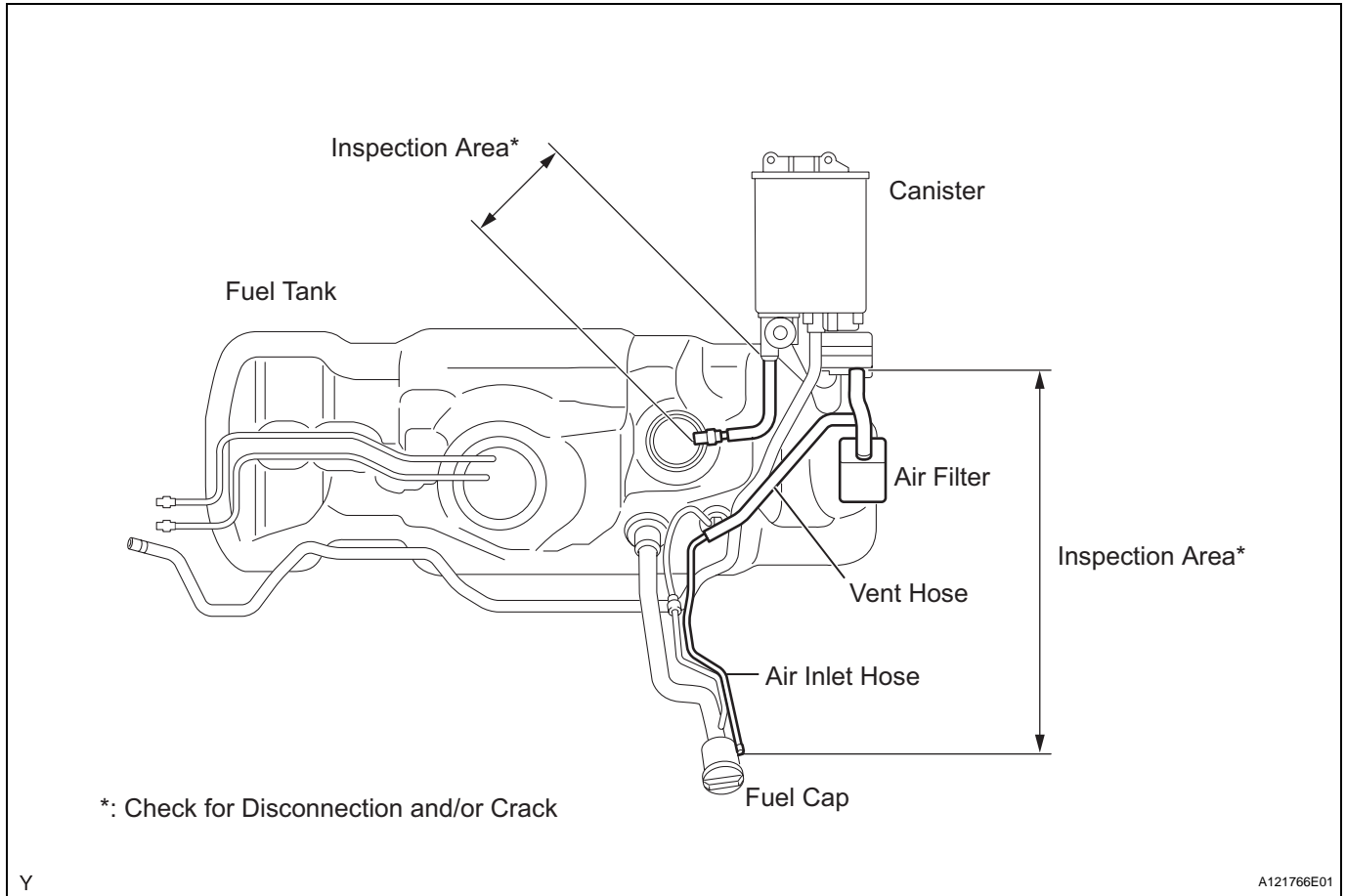
**NOTICE:**

When replacing the canister, check the canister pump module interior and related pipes for water, fuel or other liquids. If liquids are present, check for disconnections and/or cracks in the following: 1) the pipe from the air inlet port to the canister pump module; 2) the canister filter; and 3) the fuel tank vent hose.

**NEXT** **Go to step 37**

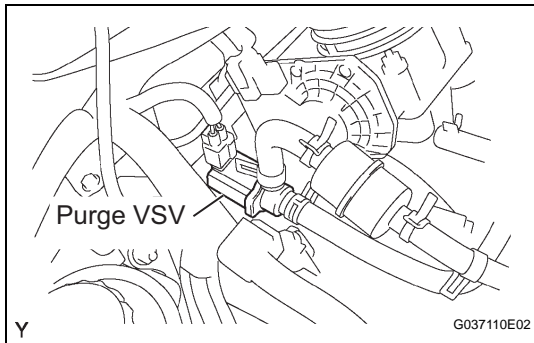
**31 REPLACE DUTY VACUUM SWITCHING VALVE (PURGE VSV)**

- (a) Disconnect the connector and the hoses from the purge VSV.
- (b) Remove the purge VSV.
- (c) Install a new purge VSV.
- (d) Reconnect the connector and hoses.

**NEXT****Go to step 37****ES****32 REPAIR OR REPLACE HARNESS AND CONNECTOR****NEXT****Go to step 37****33 REPLACE EVAP HOSE (INTAKE MANIFOLD - PURGE VSV)****NEXT****Go to step 37****34 INSPECT INTAKE MANIFOLD (EVAP PURGE PORT)**

- (a) Check that the EVAP purge port of the intake manifold is not clogged. If necessary, replace the intake manifold.

**NEXT****Go to step 37****35 REPLACE ECM**

- (a) replace the ECM (See page [ES-467](#)).

**NEXT****Go to step 37****36 REPAIR OR REPLACE PARTS AND COMPONENTS INDICATED BY OUTPUT DTCS**

- (a) Repair the malfunctioning areas indicated by the DTCs that had been confirmed when the vehicle was brought in.

**NEXT****Go to step 37**

<b>37</b>	<b>PERFORM EVAP SYSTEM CHECK (AUTO OPERATION)</b>
-----------	---

**NOTICE:**

- The **EVAP SYSTEM CHECK (AUTO OPERATION)** consists of five steps performed automatically by the intelligent tester. It takes a maximum of approximately 18 minutes.
- Do not perform the **EVAP SYSTEM CHECK** when the fuel tank is more than 90 % full because the cut-off valve may be closed and making the leak check of the fuel tank unavailable.
- Do not run the engine in this step.
- When the temperature of the fuel is 35°C (95°F) or more, a large amount of vapor forms and any check results become inaccurate. When performing an **EVAP SYSTEM CHECK**, keep the temperature below 35°C (95°F).
  - (a) Clear DTCs (see page [ES-40](#)).
  - (b) On the intelligent tester, select the following menu items: DIAGNOSIS / ENHANCED OBD II / SYSTEM CHECK / EVAP SYS CHECK / AUTO OPERATION.
  - (c) After the SYSTEM CHECK is completed, check for pending DTCs by selecting the following menu items: DIAGNOSIS / ENHANCED OBD II / DTC INFO / PENDING CODES.

**HINT:**

If no pending DTC is found, the repair has been successfully completed.

<b>NEXT</b>
-------------

<b>COMPLETED</b>
------------------

**CONFIRMATION DRIVING PATTERN****HINT:**

After a repair, check Monitor Status by performing the Key-Off Monitor Confirmation and Purge Flow Monitor Confirmation described below.

**1. KEY-OFF MONITOR CONFIRMATION****(a) Preconditions**

The monitor will not run unless:

- The vehicle has been driven for 10 minutes or more (in a city area or on a free way)
- The fuel tank is less than 90 % full
- The altitude is less than 8,000 ft (2,400 m)
- The Engine Coolant Temperature (ECT) is between 4.4°C and 35°C (40°F and 95°F)
- The Intake Air Temperature (IAT) is between 4.4°C and 35°C (40°F and 95°F)
- The vehicle remains stationary (the vehicle speed is 0 mph [0 km/h])

**(b) Monitor Conditions**

1. Allow the engine to idle for at least 5 minutes.
2. Turn the ignition switch to OFF and wait for 6 hours (8 or 10.5 hours).

**HINT:**

Do not start the engine until checking MONITOR STATUS. If the engine is started, the steps described above must be repeated.

**ES**



## (c) Monitor Status

1. Connect an intelligent tester to the DLC3.
2. Turn the ignition switch to ON and turn the tester ON.
3. Select the following menu items: DIAGNOSIS / ENHANCED OBD II / MONITOR STATUS.
4. Check the Monitor Status displayed on the tester.

## HINT:

If INCMP is displayed, the monitor is not completed. Make sure that the preconditions have been met, and perform the Monitor Conditions again.

**2. PURGE FLOW MONITOR CONFIRMATION (P0441)**

## HINT:

Perform this monitor confirmation after the Key-Off Monitor Confirmation shows COMPL (complete).

## (a) Preconditions

The monitor will not run unless:

- The vehicle has been driven for 10 minutes or more (in a city area or on a free way)
- The ECT is between 4.4°C and 35°C (40°F and 95°F)
- The IAT is between 4.4°C and 35°C (40°F and 95°F)

## (b) Monitor Conditions

1. Release the pressure from the fuel tank by removing and reinstalling the fuel cap.
2. Warm the engine up until the ECT reaches more than 75°C (167°F).
3. Increase the engine speed to 3,000 rpm once.
4. Allow the engine to idle and turn A/C ON for 1 minute.

## (c) Monitor Status

1. Turn the ignition switch to OFF (where ON or the engine is running).
2. Connect an intelligent tester to the DLC3.
3. Turn the ignition switch to ON and turn the tester ON.
4. Select the following menu items: DIAGNOSIS / ENHANCED OBD II / MONITOR STATUS.
5. Check the Monitor Status displayed on the tester.

## HINT:

If INCMP is displayed, the monitor is not completed. Make sure that the preconditions have been met, and perform the Monitor Conditions again.

**MONITOR RESULT**

Refer to Checking Monitor Status (See page [ES-21](#)).

The test value and test limit information are described as shown in the following table. This information is included under MONITOR RESULT in the emissions-related DTC sections:

- MID (Monitor Identification Data) is assigned to each emissions-related component.
- TID (Test Identification Data) is assigned to each test value.
- Scaling is used to calculate the test value indicated on generic OBD II scan tools.

**Thermostat**

MID	TID	Scaling	Description of Test Value	Minimum Test Limit	Maximum Test Limit
\$3D	\$C9	Multiply by 0.001 [kPa]	Test value for small leak (P0456) Refer to pressure D*	Minimum test limit for small leak	Maximum test limit for small leak
\$3D	\$CA	Multiply by 0.001 [kPa]	Test value for gross leak (P0455) Refer to pressure E*	Minimum test limit for gross leak	Maximum test limit for gross leak
\$3D	\$CB	Multiply by 0.001 [kPa]	Test value for leak detection pump stuck OFF (P2401) Refer to pressure A*	Minimum test limit for leak detection pump stuck OFF	Maximum test limit for leak detection pump stuck OFF
\$3D	\$CD	Multiply by 0.001 [kPa]	Test value for leak detection pump stuck ON (P2402) Refer to pressure A*	Minimum test limit for leak detection pump stuck ON	Maximum test limit for leak detection pump stuck ON

MID	TID	Scaling	Description of Test Value	Minimum Test Limit	Maximum Test Limit
\$3D	\$CE	Multiply by 0.001 [kPa]	Test value for vent valve stuck OFF (vent) (P2420) Refer to pressure C*	Minimum test limit for vent valve stuck ON	Maximum test limit for vent valve stuck ON
\$3D	\$CF	Multiply by 0.001 [kPa]	Test value for vent valve stuck ON (P2419) Refer to pressure A*	Minimum test limit for vent valve stuck OFF	Maximum test limit for vent valve stuck OFF
\$3D	\$D0	Multiply by 0.001 [kPa]	Test value for reference orifice low flow (P043E) Refer to pressure B*	Minimum test limit for reference orifice low flow	Maximum test limit for reference orifice low flow
\$3D	\$D1	Multiply by 0.001 [kPa]	Test value for reference orifice high flow (P043F) Refer to pressure A*	Minimum test limit for reference orifice high flow	Maximum test limit for reference orifice high flow
\$3D	\$D4	Multiply by 0.001 [kPa]	Test value for Purge VSV stuck closed (P0441) Refer to pressure F*	Minimum test limit for Purge VSV stuck closed	Maximum test limit for Purge VSV stuck closed
\$3D	\$D5	Multiply by 0.001 [kPa]	Test value for Purge VSV stuck open (P0441) Refer to pressure E*	Minimum test limit for Purge VSV stuck open	Maximum test limit for Purge VSV stuck open
\$3D	\$D7	Multiply by 0.001 [kPa]	Test value for purge flow (P0441) Refer to pressure G*	Minimum test limit for purge flow	Maximum test limit for purge flow

\* Pressures A to G are indicated as shown in the diagram below.

**Key-off Monitor:**

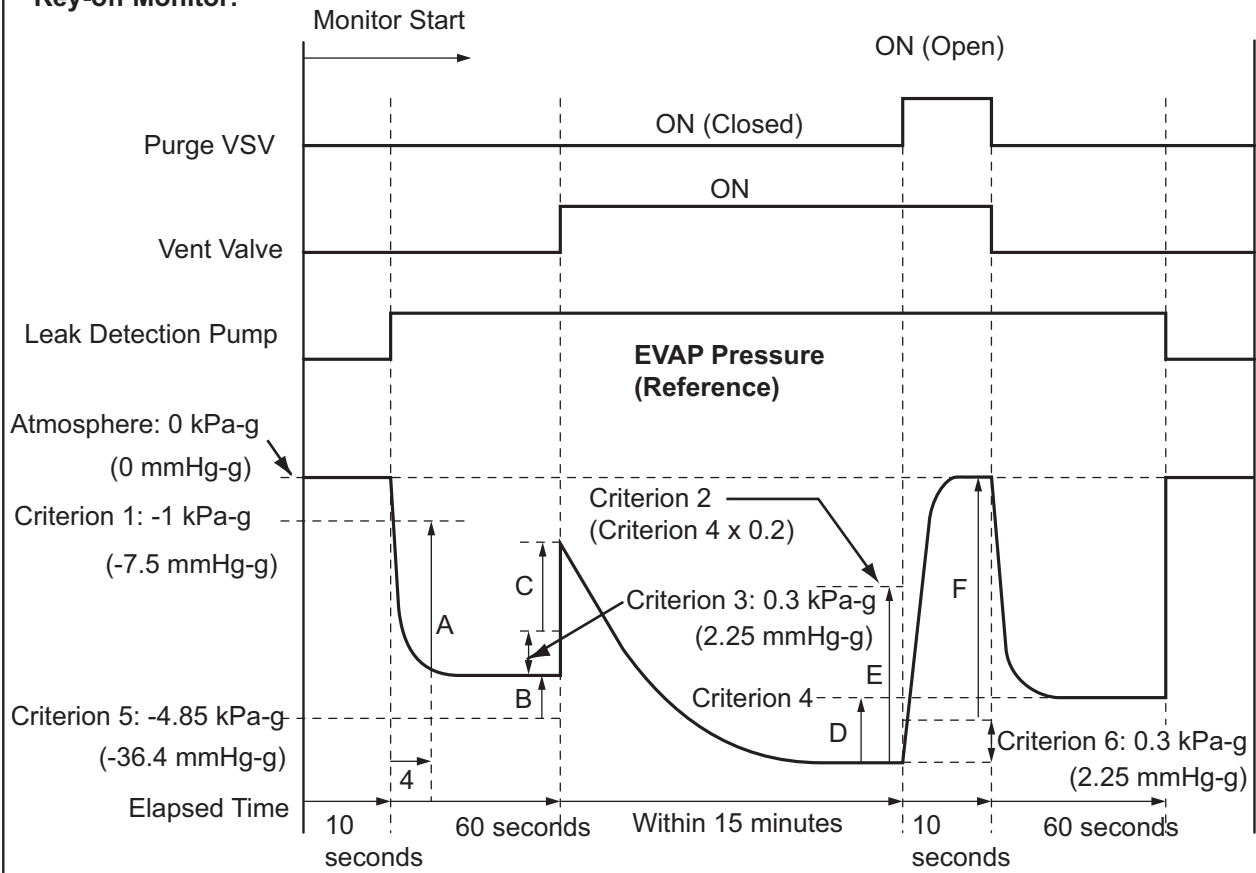

**Purge Flow Monitor:**

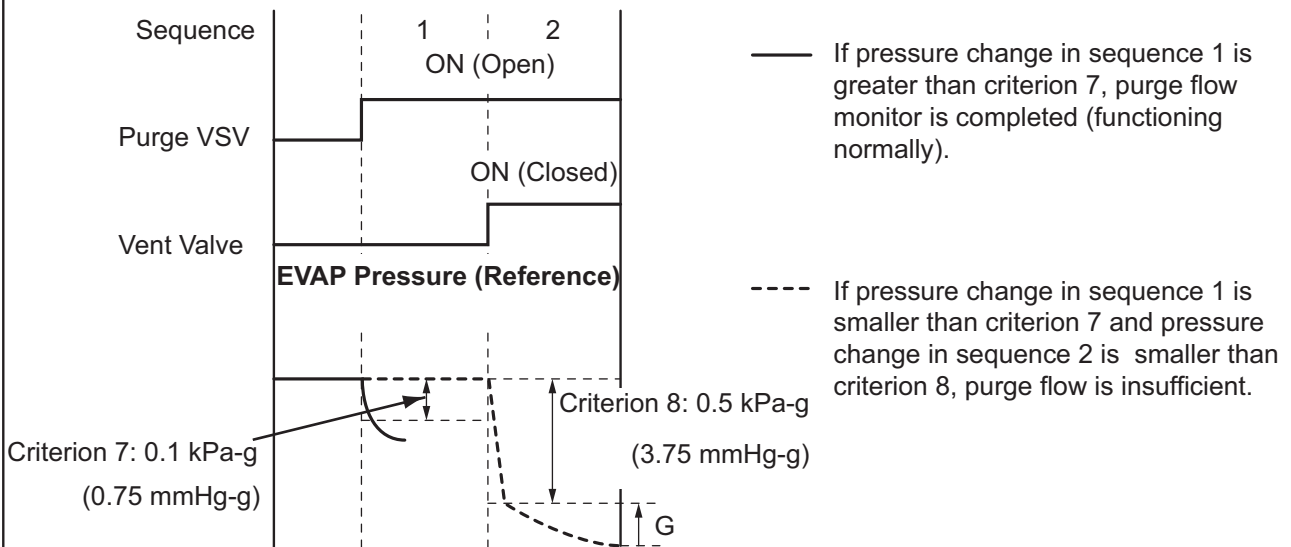

ES