

MIL Circuit

DESCRIPTION

The MIL (Malfunction Indicator Lamp) is used to indicate vehicle malfunction detections by the ECM. By turning the ignition switch to ON, power is supplied to the MIL circuit, and the ECM provides the circuit ground which illuminates the MIL.

The MIL operation can be checked visually: When the ignition switch is first turned to ON, the MIL should be illuminated and should then turn OFF. If the MIL remains illuminated or is not illuminated, conduct the following troubleshooting procedure using an intelligent tester.

WIRING DIAGRAM

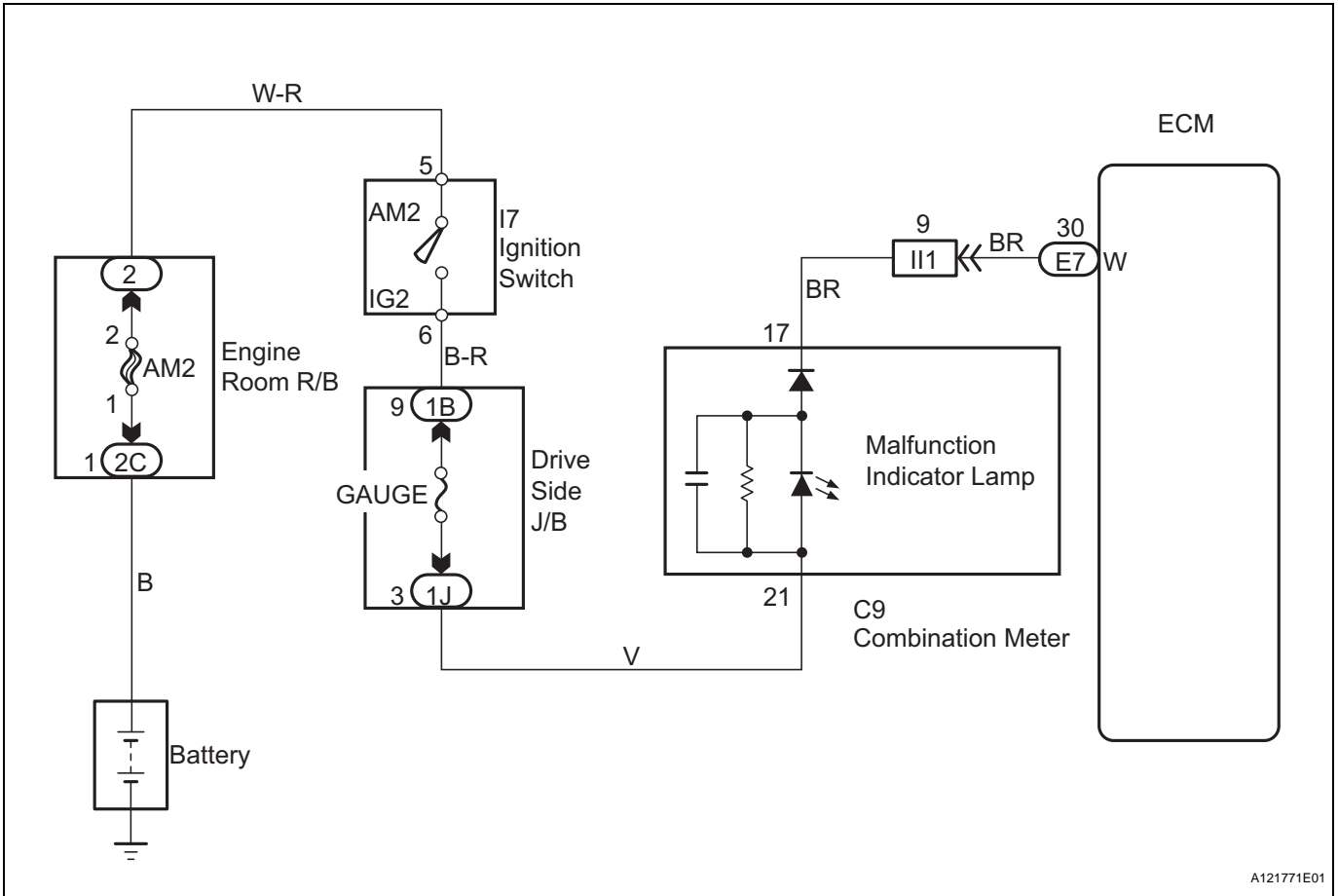

ES

1 CHECK THAT MIL IS ILLUMINATED

(a) Perform troubleshooting in accordance with the chart below.

Result

MIL Condition	Proceed To
MIL remains ON	A
MIL does not illuminate	B

B Go to step 4

A

2 CHECK WHETHER MIL TURNS OFF

- (a) Connect an intelligent tester to the DLC3.
- (b) Turn the ignition switch to ON.
- (c) Turn the tester ON.
- (d) Check whether any DTCs have been stored (see page [ES-40](#)). Note them down if necessary.
- (e) Clear DTCs (see page [ES-40](#)).
- (f) Check if the MIL turns off.

OK:**MIL should turn off.**

OK

REPAIR CIRCUITS INDICATED BY OUTPUT DTCS

ES

NG

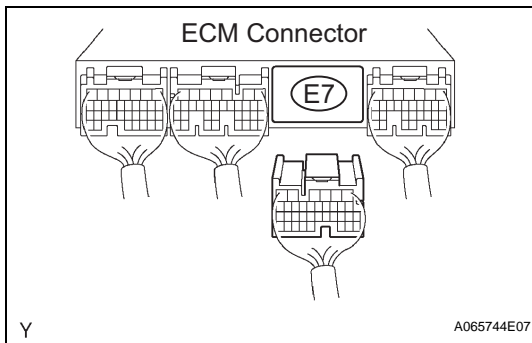
3 CHECK HARNESS AND CONNECTOR (CHECK FOR SHORT IN WIRE HARNESS)

- (a) Disconnect the ECM connector.
- (b) Turn the ignition switch to ON.
- (c) Check that the MIL is not illuminated.

OK:**MIL is not illuminated.**

- (d) Reconnect the ECM connector.

OK

REPLACE ECM

NG

CHECK AND REPLACE HARNESS AND CONNECTOR**4 CHECK THAT MIL IS ILLUMINATED**

- (a) Check if the MIL is illuminated when the ignition switch is turned to ON.

OK:**MIL should be illuminated.**

OK

SYSTEM OK

NG

5 CHECK THAT ENGINE STARTS

- (a) Turn the ignition switch to ON
- (b) Start the engine.

Result

Result	Proceed To
Engine starts	A
Engine does not start*	B

HINT:

*: The intelligent tester cannot communicate with the ECM.

B**GO TO VC OUTPUT CIRCUIT****A****6****INSPECT COMBINATION METER ASSEMBLY (MIL CIRCUIT)**(a) See the combination meter troubleshooting procedure
(See page [ME-7](#)).**NG****REPAIR OR REPLACE BULB OR
COMBINATION METER ASSEMBLY****OK****CHECK AND REPLACE HARNESS AND CONNECTOR (COMBINATION METER - ECM)**