

INSTALLATION

1. INSTALL CYLINDER HEAD GASKET

- (a) Remove any old packing (FIPG) material and be careful not to drop any oil on the contact surfaces of the cylinder head and cylinder block.
- (b) Apply a continuous bead of the seal packing (diameter 2.5 to 3 mm (0.098 to 0.118 in.)) to a new cylinder head gasket as shown in the illustration.

Seal packing:

Part No. 08826-00080 or equivalent

NOTICE:

Install the cylinder head within 3 minutes of applying seal packing. Tighten the cylinder head bolts within 15 minutes of installing the cylinder head. Otherwise, the seal packing must be removed and reapplied.

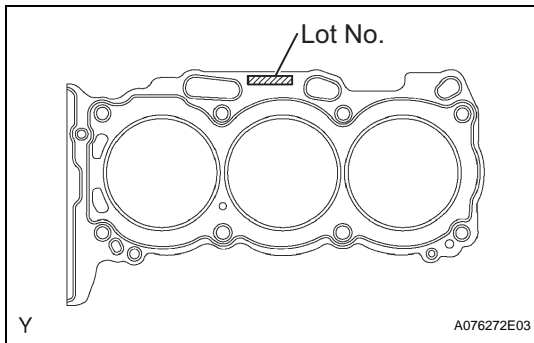
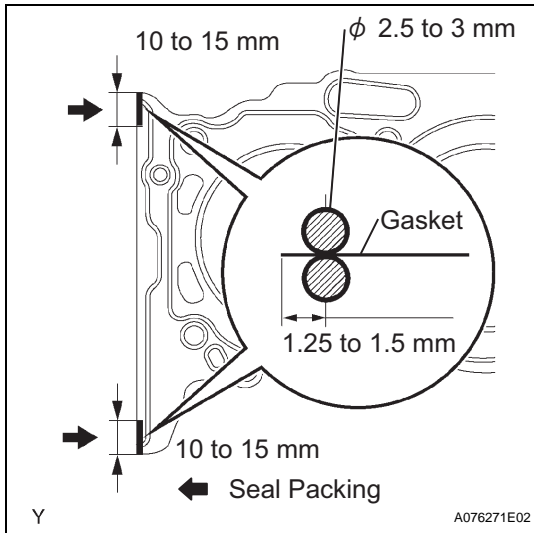

- (c) Place the cylinder head gasket on the cylinder block surface with the Lot No. stamp upward.

NOTICE:

- Be careful of the installation direction.
- Place the cylinder head carefully in order not to damage the gasket with the bottom part of the head.

2. INSTALL CYLINDER HEAD SUB-ASSEMBLY

- (a) Place the cylinder head on the cylinder head gasket.
- (b) Install the 8 cylinder head bolts.

HINT:

- The cylinder head bolts are tightened in 2 successive steps (steps (3) and (5)).
- If any cylinder head bolts are broken or deformed, replace them.

- (1) Apply a light coat of engine oil to the threads of the cylinder head bolts.

- (2) Install the plate washer onto the cylinder head bolt.

- (3) Using several steps, tighten each bolt uniformly with a 10 mm bi-hexagon wrench in the sequence shown in the illustration.

Torque: 36 N*m (367 kgf*cm, 27 ft.*lbf)

If any cylinder head bolts do not meet the torque specification, replace them.

NOTICE:

Do not drop the washers into the cylinder head.

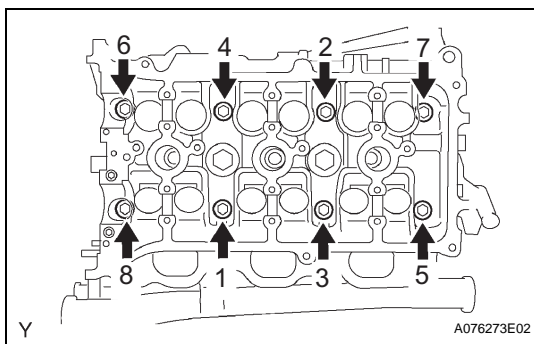

EM

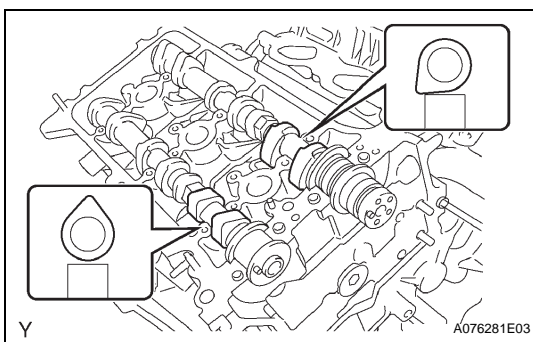
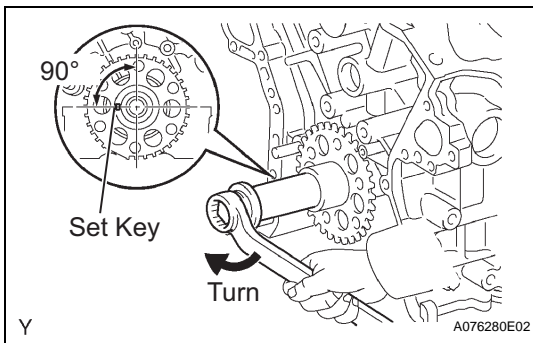
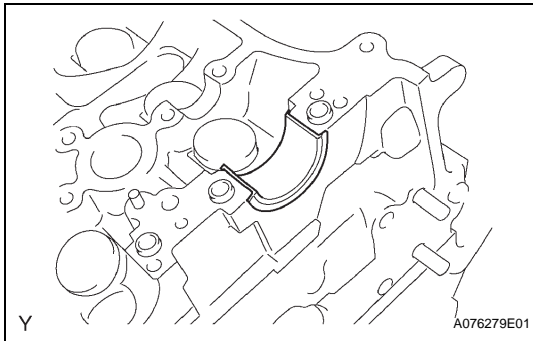
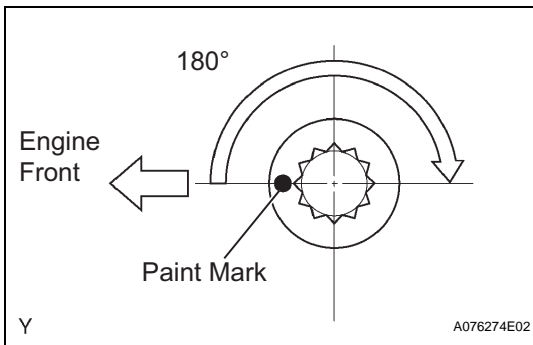

- (4) Mark the front side of each cylinder head bolt with paint.
 - (5) Retighten the cylinder head bolts 180° as shown.
 - (6) Check that the painted marks are now at 180° from the engine front.
- (c) Install the ground cables with the 2 bolts.
Torque: 8.0 N*m (82 kgf*cm, 71 in.*lbf)

3. INSTALL NO.2 CAMSHAFT BEARING

- (a) Install the camshaft bearing No. 2 onto the cylinder head.

NOTICE:

Clean the installation planes of the back side of the bearing and cylinder head and keep them free of oils and fats.

4. INSTALL CAMSHAFTS

NOTICE:

Keep the camshaft level while it is being removed. The camshaft thrust clearance is very small and failing to keep it level could crack or damage the cylinder head journal surface, which receives the thrust. This could subsequently lead the camshaft to seize or break. Perform the following steps to avoid such problems.

- (a) Set the crankshaft position.
 - (1) Using the crankshaft pulley set bolt, turn the crankshaft, and set the crankshaft set key in the left horizontal position.

NOTICE:
Installing the crankshaft at the wrong angle could cause the piston head and valve head to come into contact with each other when installing the camshaft. This could cause damage, so always set the crankshaft at the correct angle.
- (b) Apply new engine oil to the thrust portion and journal of the camshafts.
- (c) Place the 2 camshafts onto the cylinder head with the cam lobes of No. 1 cylinder facing in the directions shown in the illustration.

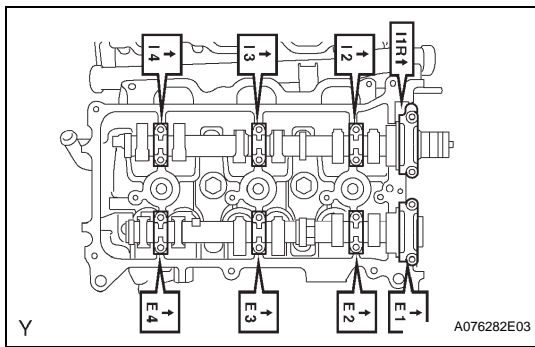

- (d) Install the 8 bearing caps in the proper locations as shown.
- (e) Apply a light coat of engine oil to the threads and under the heads of the bearing cap bolts.

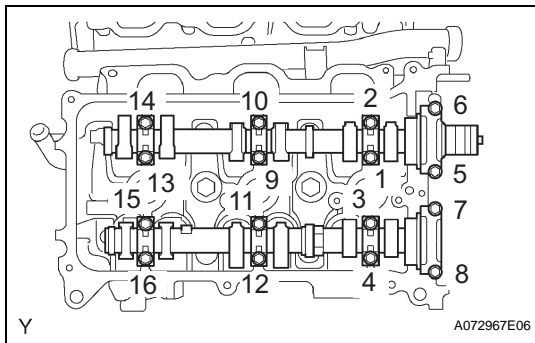

- (f) Using several steps, uniformly install and tighten the 16 bearing cap bolts in the sequence shown in the illustration.

Torque: 9.0 N*m (92 kgf*cm, 80 in.*lbf) for 10 mm (0.39 in.) head
24 N*m (245 kgf*cm, 18 ft.*lbf) for 12 mm (0.47 in.) head

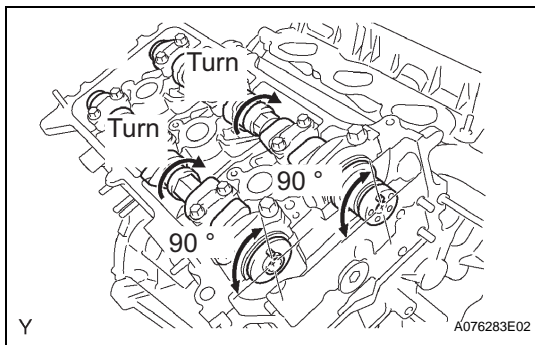

- (g) Turn the camshafts clockwise until the knock pin comes to a position 90° to the cylinder head.

5. INSTALL NO.2 CHAIN TENSIONER ASSEMBLY

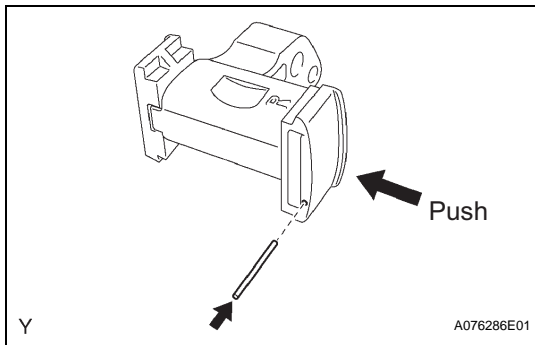

- (a) While pushing in the tensioner, insert a pin of ϕ 1.0 mm (0.039 in.) into the hole to fix it.

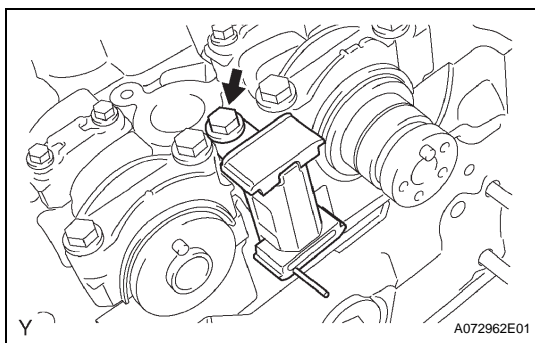

- (b) Install the chain tensioner No. 2 with the bolt.
Torque: 19 N*m (194 kgf*cm, 14 ft.*lbf)

EM

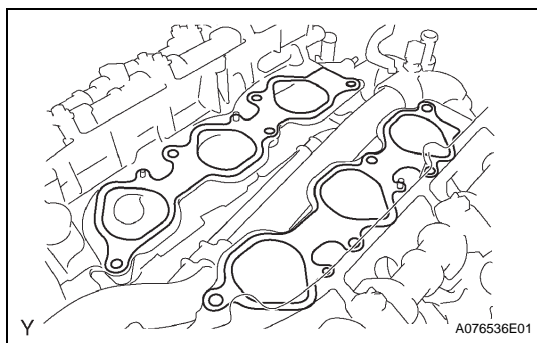
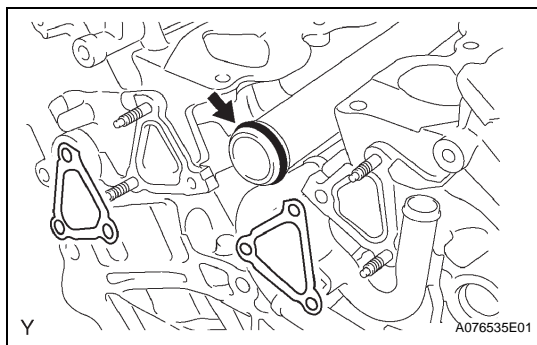
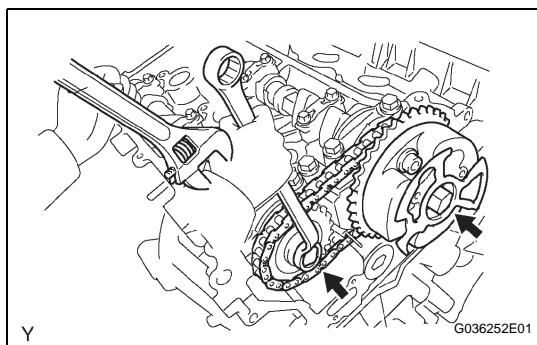
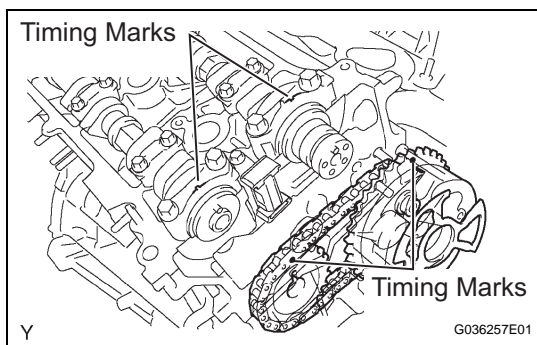
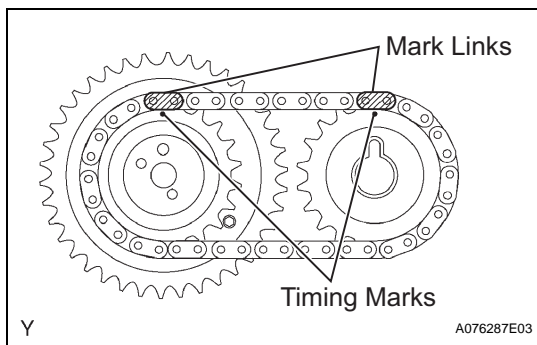

6. INSTALL CAMSHAFT TIMING GEARS AND NO.2 CHAIN (for Bank 1)

- (a) Align the yellow mark links with the timing marks (1 dot mark) of camshaft timing gears as shown in the illustration.

- (b) Align the timing marks on the camshaft timing gears with the timing marks on the bearing caps, and install the camshaft timing gears with the chain onto the RH camshafts.

- (c) Temporarily install the 2 camshaft timing gear bolts.

NOTICE:

Do not push the camshaft timing gear assembly onto the camshaft forcibly when installing it.

- (d) Hold the hexagonal portion of the camshaft with a wrench, and tighten the 2 bolts.

Torque: 100 N*m (1,020 kgf*cm, 74 ft.*lbf)

- (e) Remove the pin from the tensioner No. 2.

7. INSTALL WATER BY-PASS JOINT RR

- (a) Install a new O-ring onto the water outlet pipe.

- (b) Apply soapy water to the O-ring.

- (c) Install 2 new gaskets and water by-pass joint rear with the 2 bolts and 4 nuts.

Torque: 9.0 N*m (92 kgf*cm, 80 in.*lbf)

- (d) Connect the heater hose.

- (e) Connect the engine coolant temperature sensor connector.

8. INSTALL INTAKE MANIFOLD

- (a) Set a new gasket on each cylinder head.

NOTICE:

- **Align the port holes of the gasket and cylinder head.**

- **Be careful of the installation direction.**

- (b) Set the intake manifold on the cylinder heads.

- (c) Install and tighten the 10 bolts uniformly in several steps.

Torque: 26 N*m (265 kgf*cm, 19 ft.*lbf)

- (d) Connect the 6 fuel injector connectors.

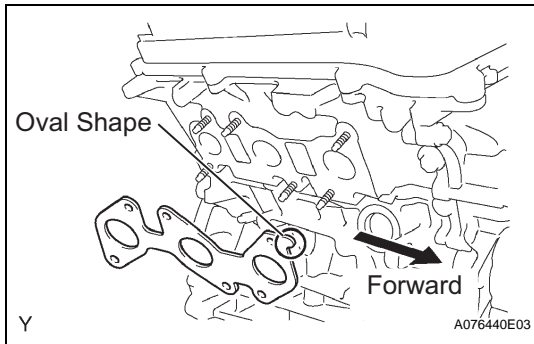

9. CONNECT NO.2 FUEL PIPE SUB-ASSEMBLY
10. CONNECT NO.1 FUEL PIPE SUB-ASSEMBLY (See page [FU-17](#))
11. INSTALL EXHAUST MANIFOLD SUB-ASSEMBLY RH
 - (a) Set a new gasket to the RH cylinder head with the oval shape facing forward.

NOTICE:
Be careful of the installation direction.
 - (b) Install the exhaust manifold with the 6 nuts. Tighten the nuts uniformly in several steps.

Torque: 21 N*m (214 kgf*cm, 16 ft.*lbf)
 - (c) Connect the air fuel ratio sensor connector.
12. INSTALL MANIFOLD STAY
 - (a) Install the manifold stay with the 3 bolts.

Torque: 40 N*m (408 kgf*cm, 30 ft.*lbf)
13. INSTALL FRONT EXHAUST PIPE ASSEMBLY (See page [EX-3](#))
14. INSTALL NO.1 COOL AIR INLET
 - (a) Install the cool air inlet with the 2 bolts.

Torque: 12 N*m (122 kgf*cm, 9.0 ft.*lbf)
15. INSTALL CHAIN TENSIONER SLIPPER
16. INSTALL NO.1 CHAIN TENSIONER ASSEMBLY (See page [EM-27](#))
17. INSTALL CHAIN SUB-ASSEMBLY (See page [EM-48](#))
18. INSTALL TIMING CHIAN OR BELT COVER SUB-ASSEMBLY [LU-38](#)
19. INSTALL FRONT DIFFERENTIAL CARRIER ASSEMBLY (for 4WD) (See page [DF-38](#))
20. INSTALL POWER STEERING LINK ASSEMBLY (See page [PS-67](#))
21. INSTALL BATTERY
22. ADD ENGINE OIL (See page [LU-5](#))
23. ADD ENGINE COOLANT (See page [CO-3](#))
24. ADD DIFFERENTIAL OIL (for 4WD)
25. INSPECT DIFFERENTIAL OIL (for 4WD) (See page [DF-8](#))
26. ADD POWER STEERING FLUID
27. BLEED POWER STEERING FLUID (See page [PS-2](#))
28. CHECK FOR ENGINE OIL LEAKAGE
29. CHECK FOR ENGINE COOLANT LEAKAGE (See page [CO-4](#))
30. CHECK FOR FUEL LEAKAGE

31. CHECK FOR EXHAUST GAS LEAKAGE
32. CHECK FOR POWER STEERING FLUID LEAKAGE
33. INSPECT AND ADJUST FRONT WHEEL ALIGNMENT
(See page [SP-7](#))
34. INSPECT IGNITION TIMING (See page [EM-1](#))
35. INSPECT ENGINE IDLING SPEED (See page [EM-2](#))
36. INSPECT CO/HC (See page [EM-3](#))
37. REMOVE COMPRESSION (See page [EM-2](#))