

CAMSHAFT (for Bank 1)

COMPONENTS

EM

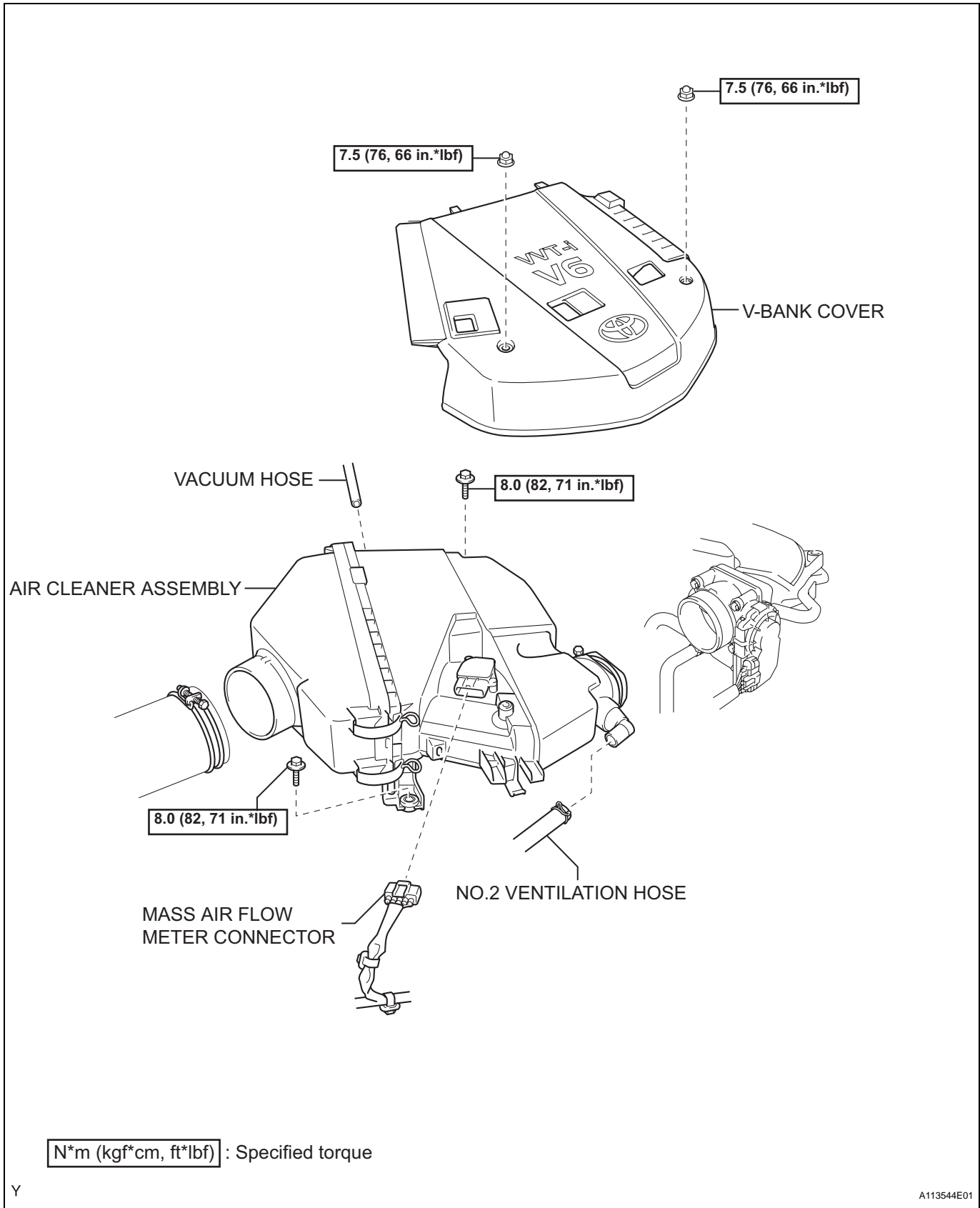

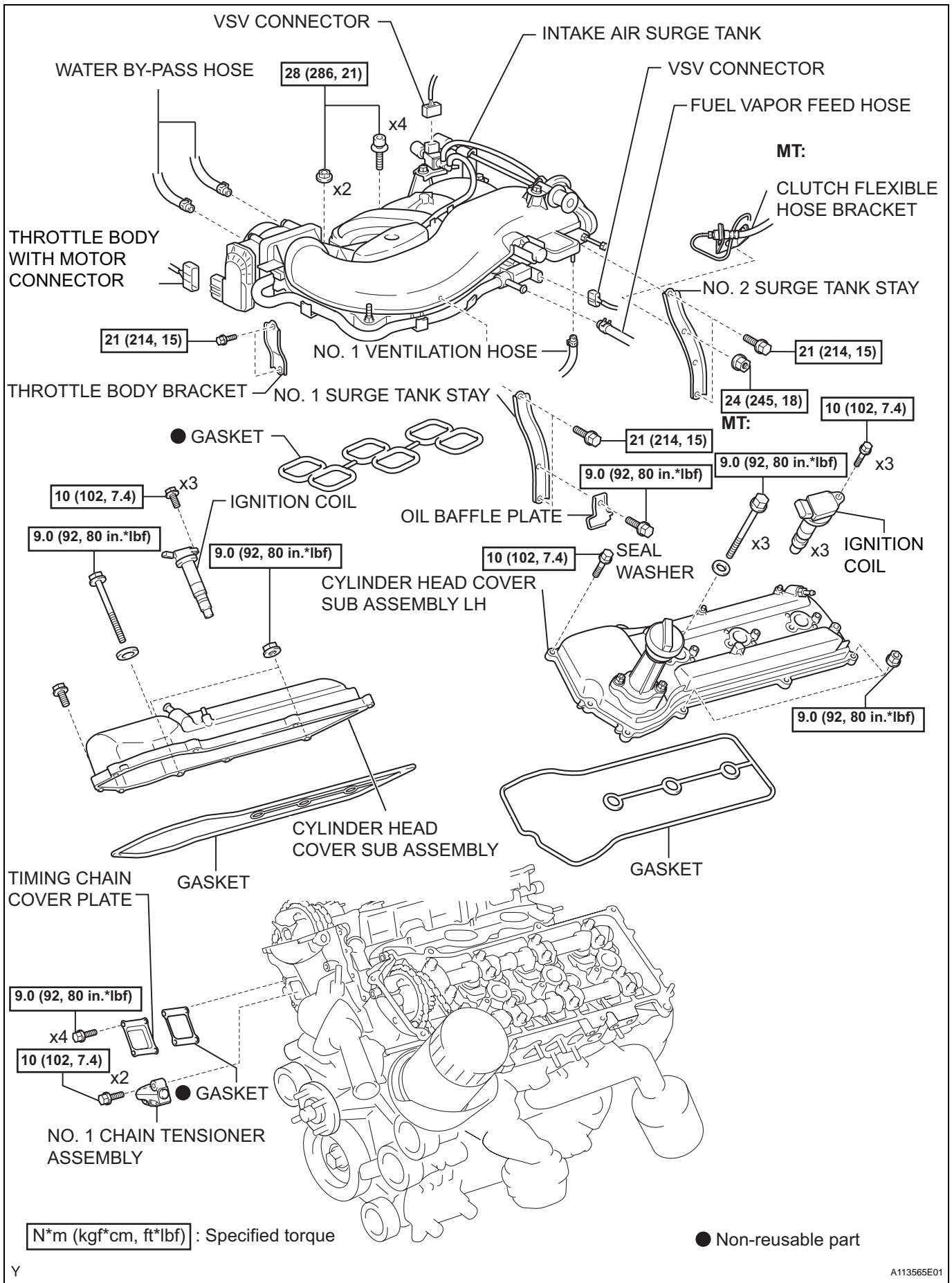

EM

EM

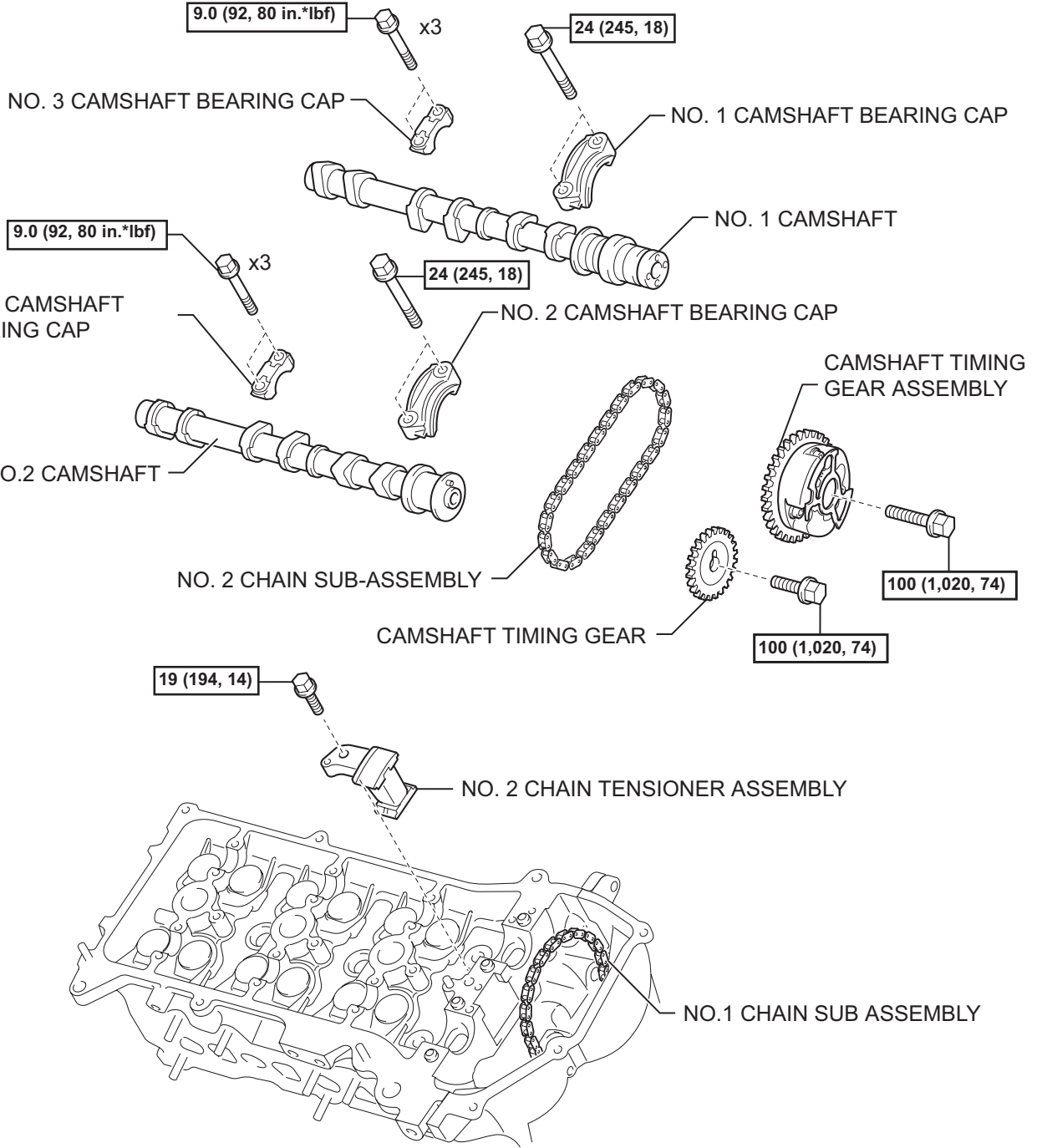

N*m (kgf*cm, ft*lbf) : Specified torque