

ENGINE UNIT

COMPONENTS

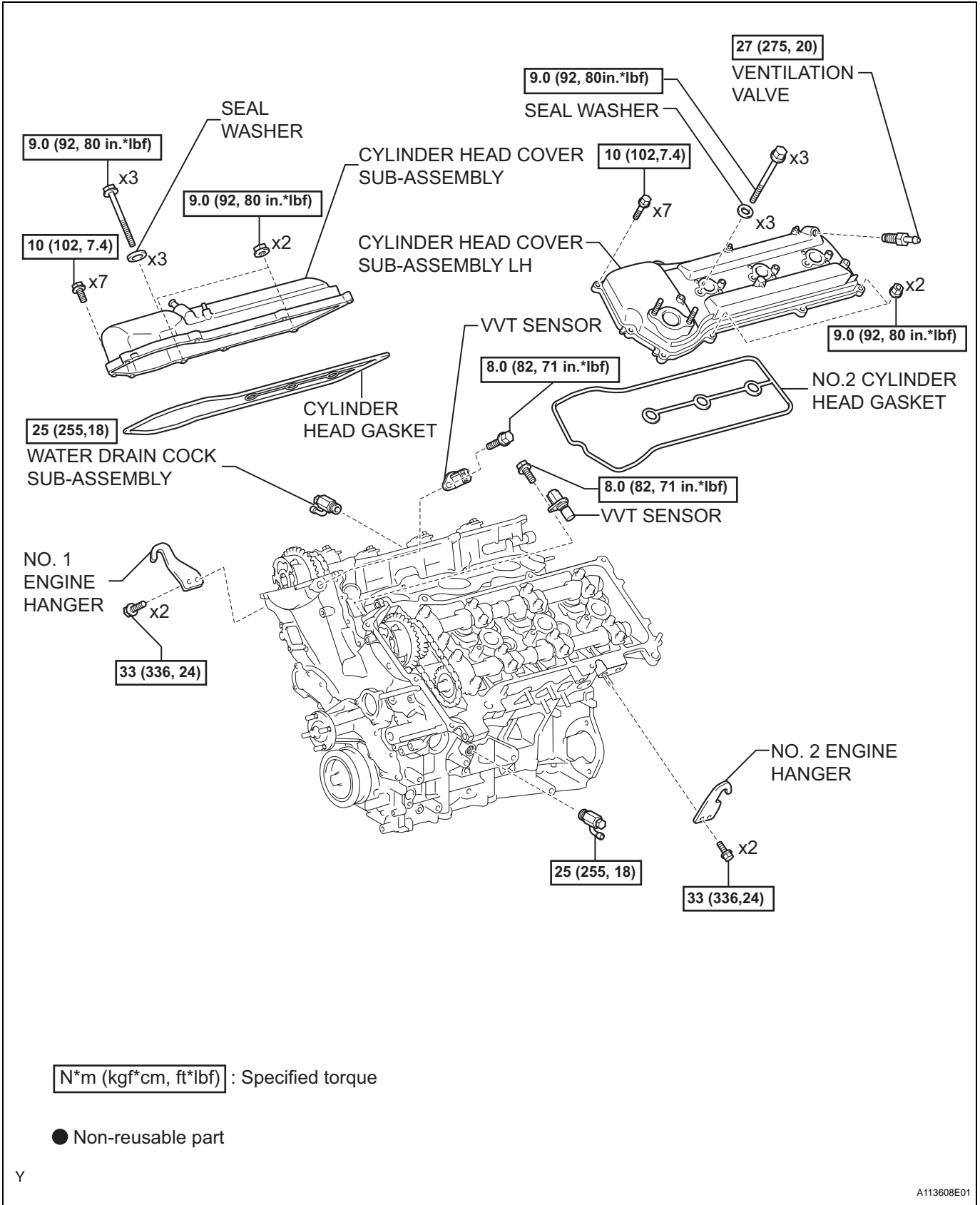

EM

EM

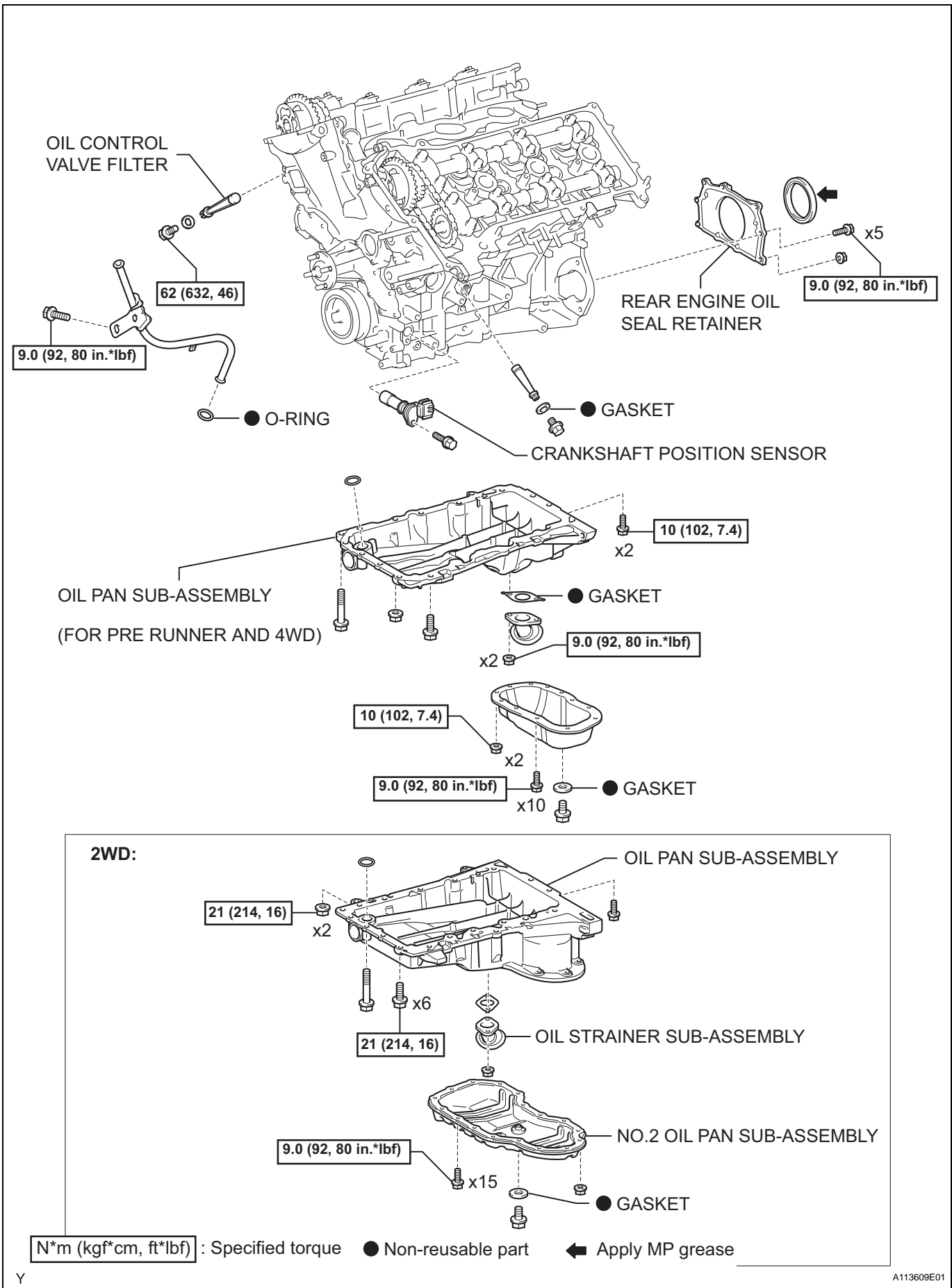

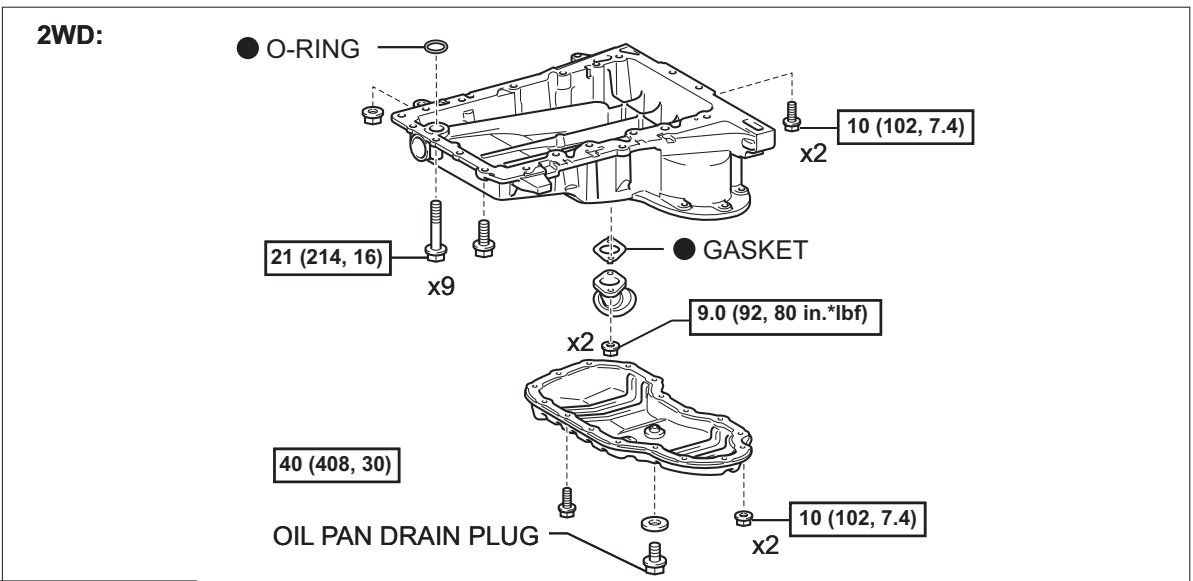
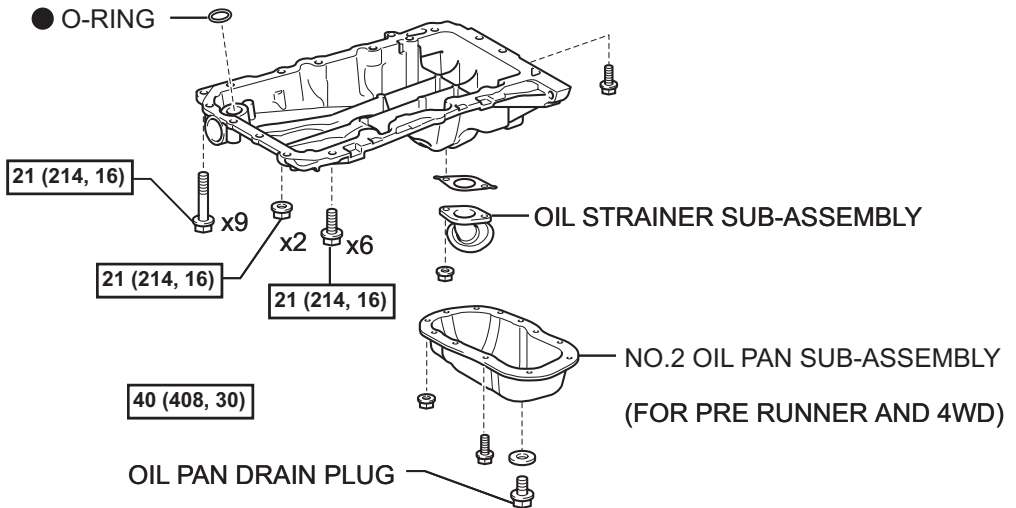
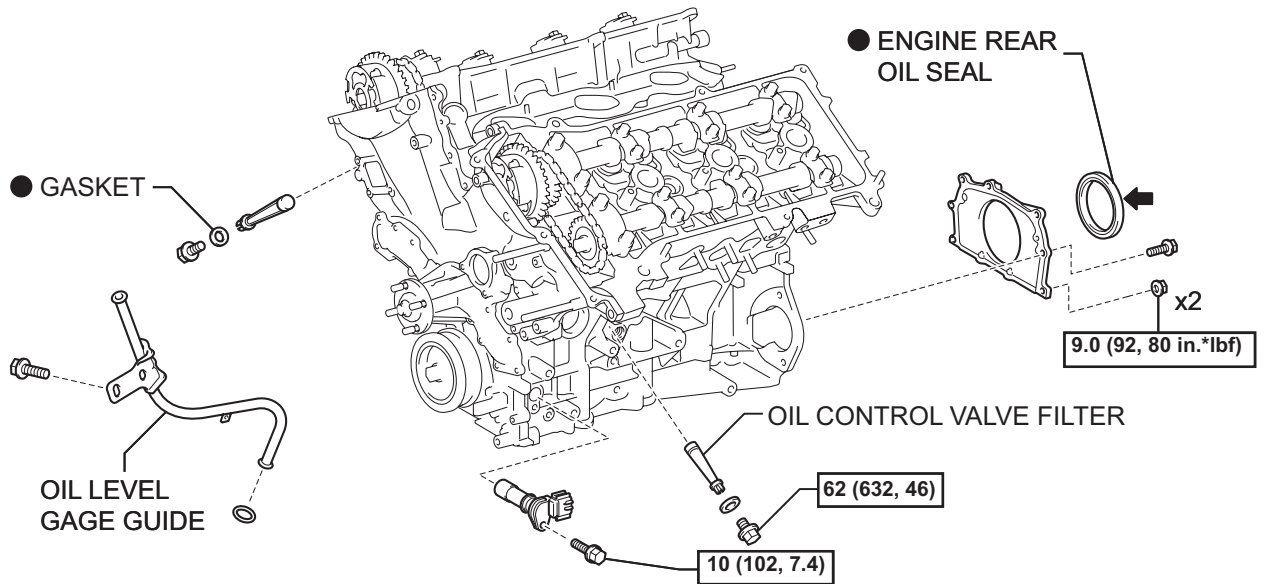

N*m (kgf*cm, ft*lbf) : Specified torque ● Non-reusable part ← Apply MP grease

EM

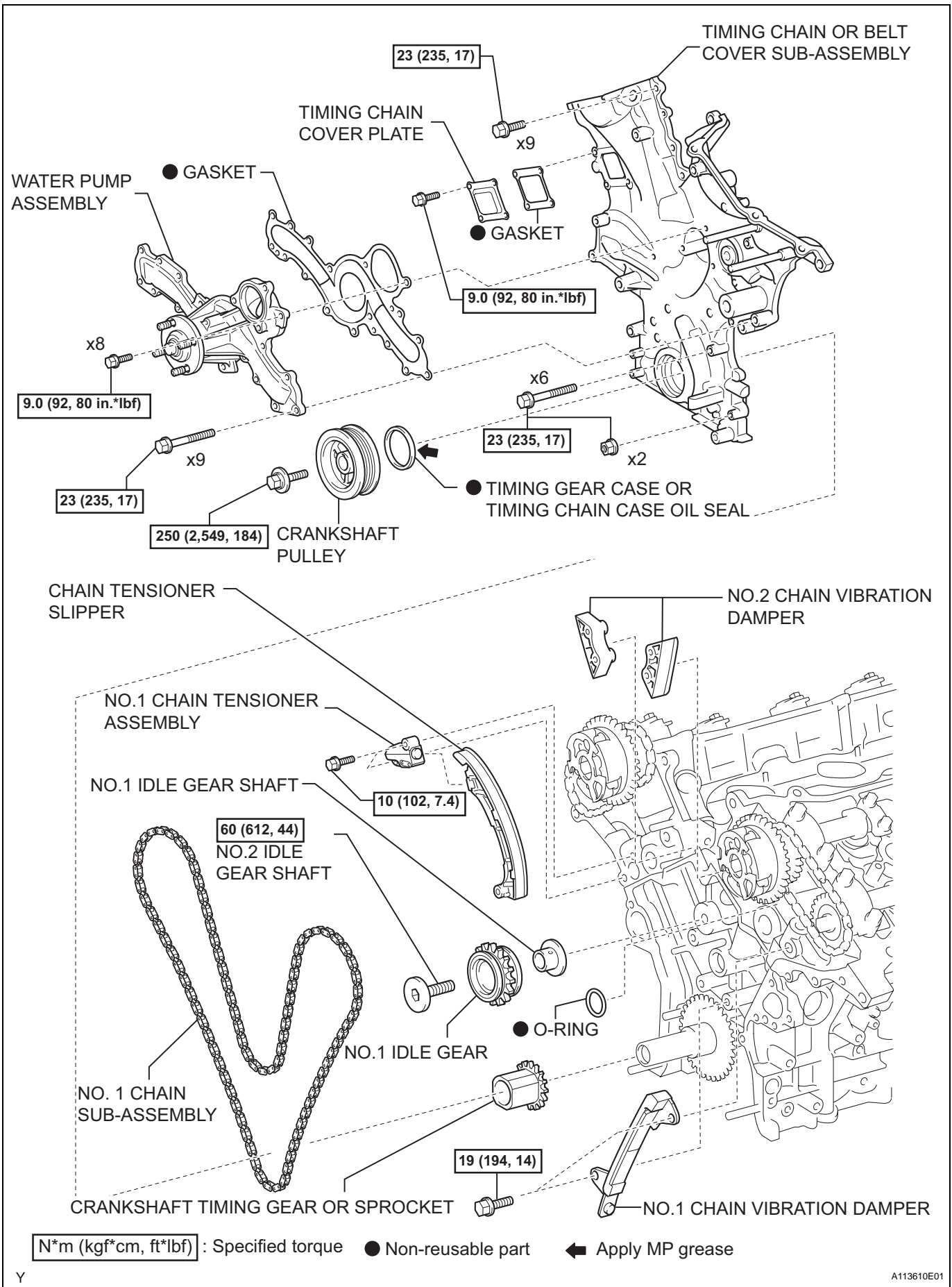

EM

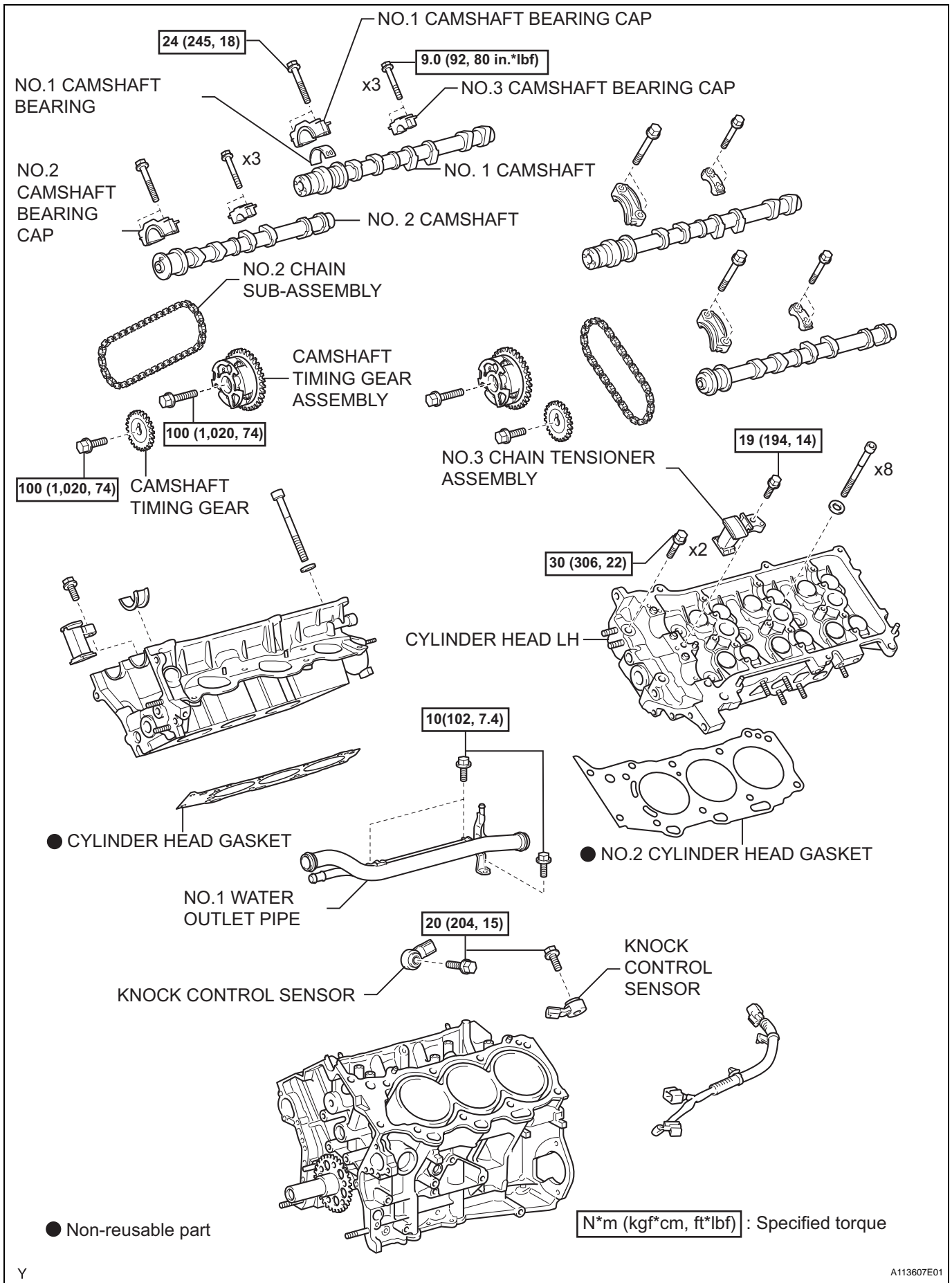

EM

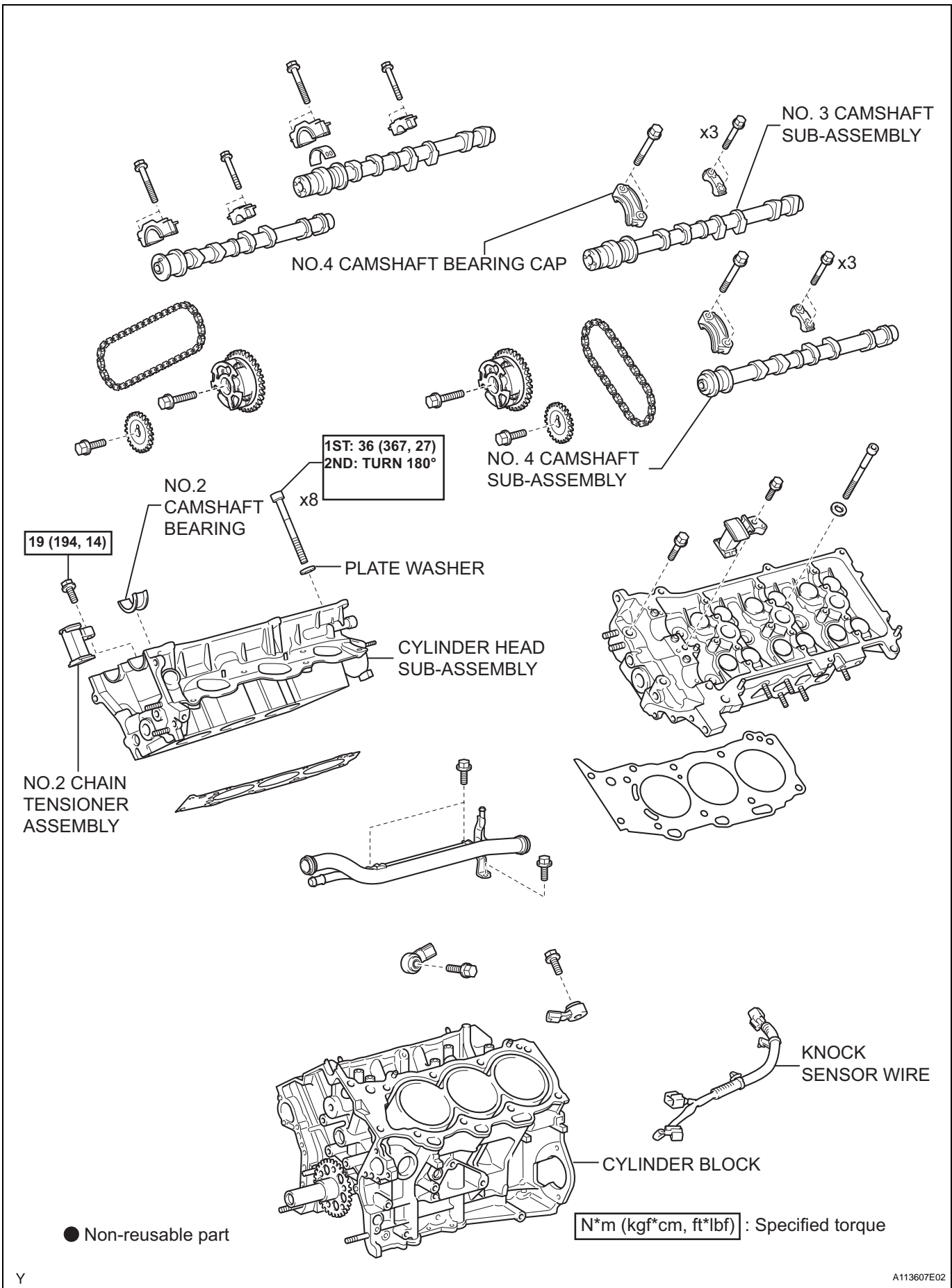

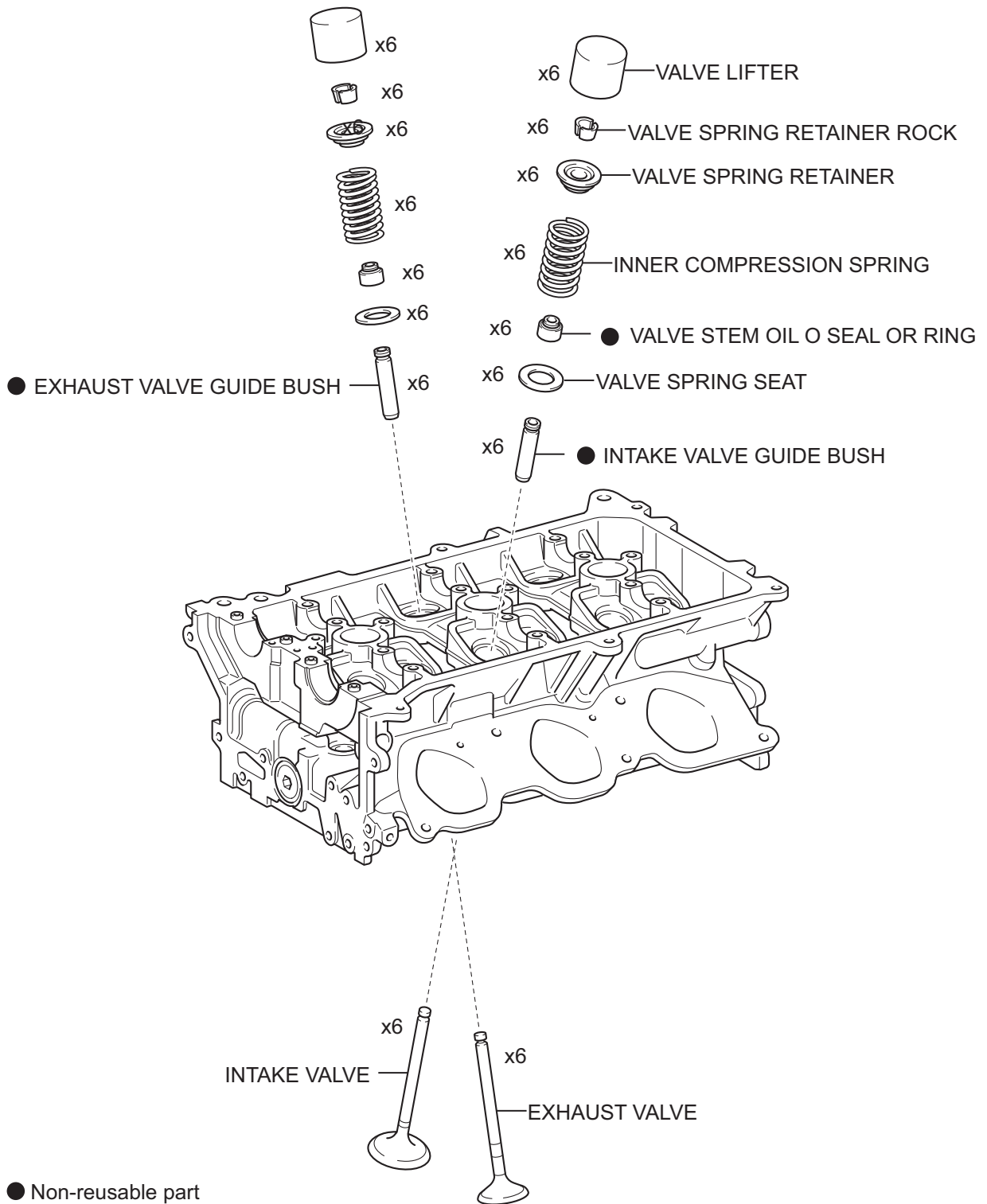

EM

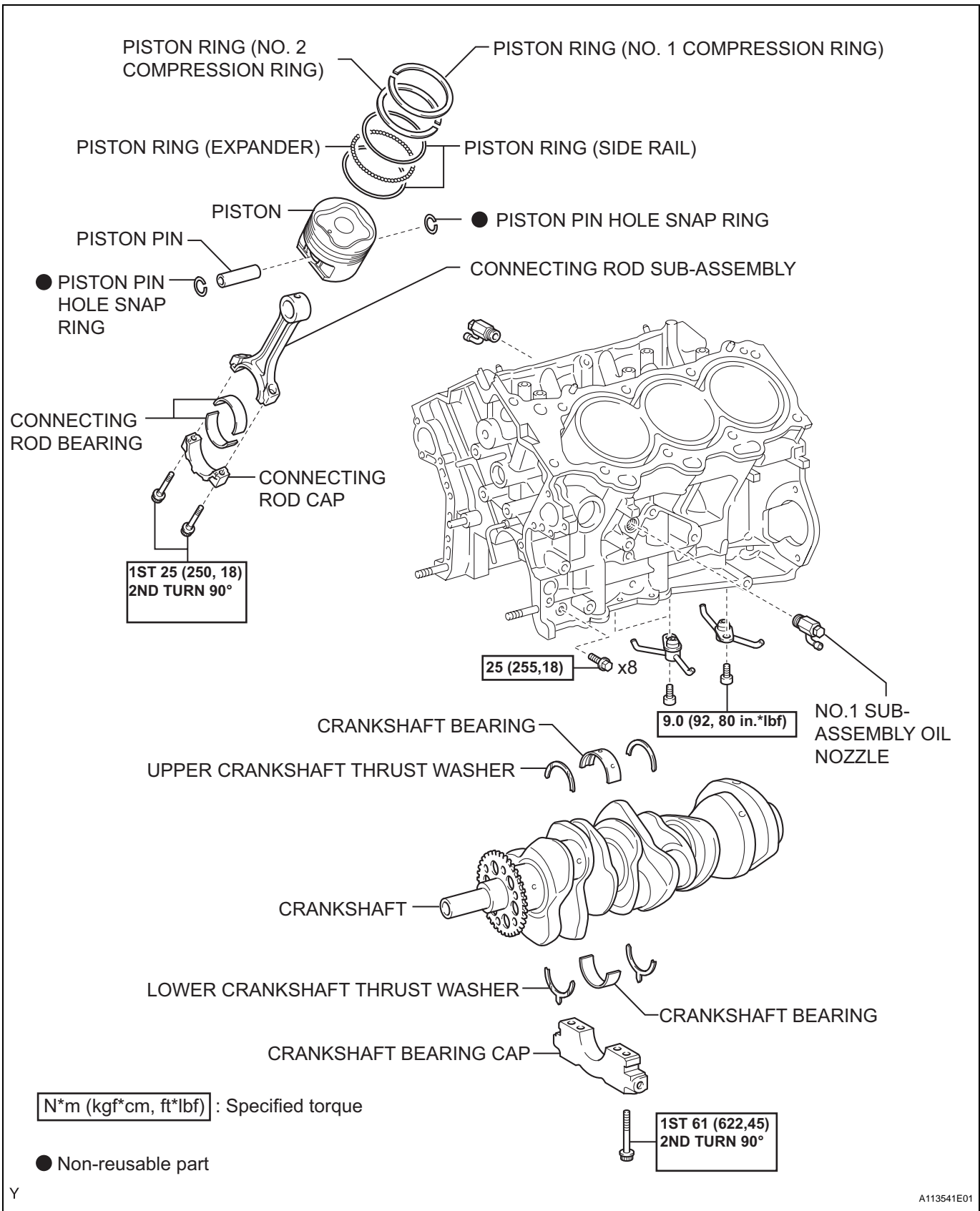

EM

Y