

# COOLING SYSTEM

## PARTS LOCATION

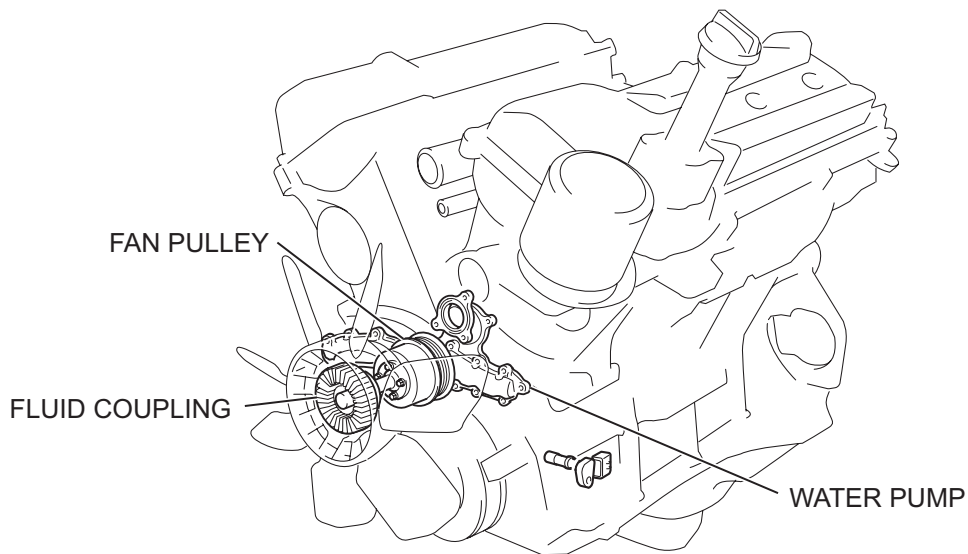
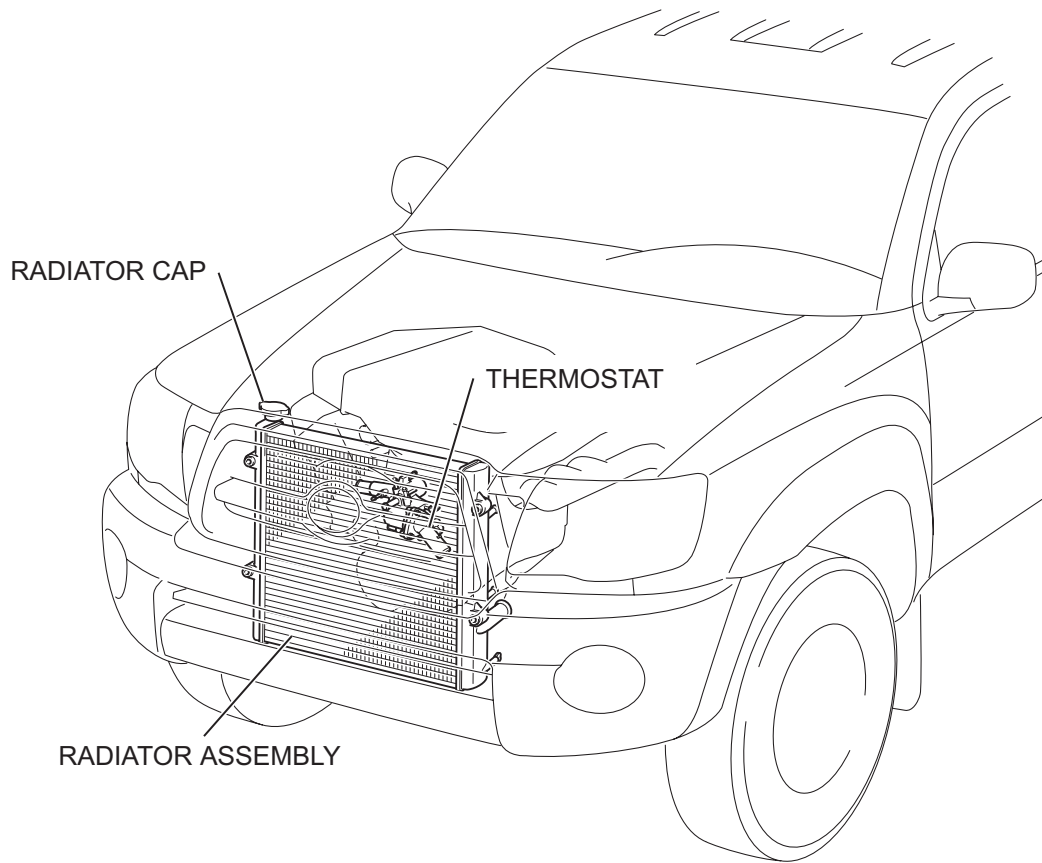

CO

## ON-VEHICLE INSPECTION

### 1. CHECK COOLING SYSTEM FOR LEAKAGE

- (a) Remove the radiator cap.

**CAUTION:**

**To avoid the danger of being burned, do not remove the radiator cap while the engine and radiator are still hot. Thermal expansion will cause hot engine coolant and steam to blow out from the radiator.**

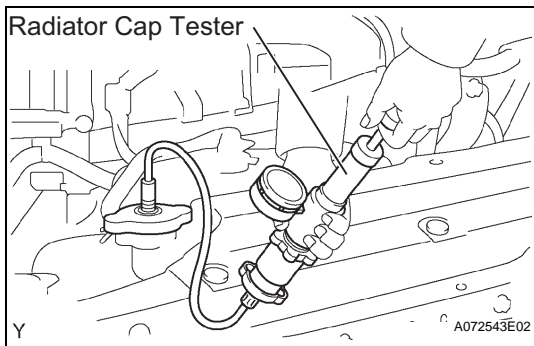

- (b) Fill the radiator with coolant and attach a radiator cap tester.
- (c) Warm up the engine.
- (d) Pump it to 118 kPa (1.2 kgf/cm<sup>2</sup>, 17.1 psi), then check that the pressure does not drop. If the pressure drops, check the hoses, radiator and water pump for leakage. If there are no signs of external coolant leakage, check the heater core, cylinder block and head.
- (e) Reinstall the radiator cap.

### 2. CHECK COOLANT LEVEL OF RESERVOIR

- (a) The engine coolant should be between the LOW and FULL lines when the engine is cold. If low, check for leakage and add Toyota Super Long Life Coolant or similar high quality ethylene glycol based non-silicate, non-amine, non-nitrite, and non-borate coolant with long-life hybrid organic acid technology up to the FULL line.

### 3. CHECK ENGINE COOLANT QUALITY

- (a) Remove the radiator cap.

**CAUTION:**

**To avoid the danger of being burned, do not remove the radiator cap while the engine and radiator are still hot. Thermal expansion will cause hot engine coolant and steam to blow out from the radiator.**

- (b) Check for any excessive deposits of rust or scale around the radiator cap and radiator filler hole; the coolant should be free of oil. If excessively dirty, replace the coolant.
- (c) Reinstall the radiator cap.