

## REMOVAL

1. **DISCHARGE FUEL SYSTEM PRESSURE**  
(See page [FU-1](#))
2. **REMOVE BATTERY**
3. **DRAIN ENGINE COOLANT** (See page [CO-3](#))
4. **DRAIN ENGINE OIL** (See page [LU-4](#))
5. **REMOVE ENGINE ASSEMBLY**  
(See page [EM-186](#))
6. **REMOVE OIL LEVEL GAUGE GUIDE**
7. **REMOVE WATER INLET** (See page [CO-9](#))
8. **REMOVE V-RIBBED BELT TENSIONER ASSEMBLY**  
(See page [EM-44](#))
9. **REMOVE NO.2 IDLER PULLEY SUB-ASSEMBLY** (See page [EM-24](#))
10. **REMOVE NO.1 IDLER PULLEY SUB-ASSEMBLY** (See page [EM-24](#))
11. **REMOVE CRANKSHAFT PULLEY** (See page [EM-45](#))
12. **REMOVE NO.2 OIL PAN SUB-ASSEMBLY** (See page [EM-24](#))
13. **REMOVE OIL STRAINER SUB-ASSEMBLY** (See page [EM-24](#))
14. **REMOVE OIL PAN SUB-ASSEMBLY** (See page [EM-25](#))
15. **REMOVE IGNITION COIL ASSEMBLY** (See page [IG-7](#))
16. **REMOVE CYLINDER HEAD COVER SUB-ASSEMBLY**  
(See page [EM-59](#))
17. **REMOVE CYLINDER HEAD COVER SUB-ASSEMBLY LH** (See page [EM-59](#))
18. **REMOVE CAMSHAFT TIMING OIL CONTROL VALVE ASSEMBLY** (See page [ES-407](#))
19. **REMOVE VVT SENSOR** (See page [IG-8](#))
20. **REMOVE OIL FILTER BRACKET SUB-ASSEMBLY**  
(a) Remove the 3 bolts, 2 nuts, oil filter bracket and gasket.
21. **REMOVE TIMING CHAIN OR BELT COVER SUB-ASSEMBLY**  
(a) Remove the 24 bolts and 2 nuts.

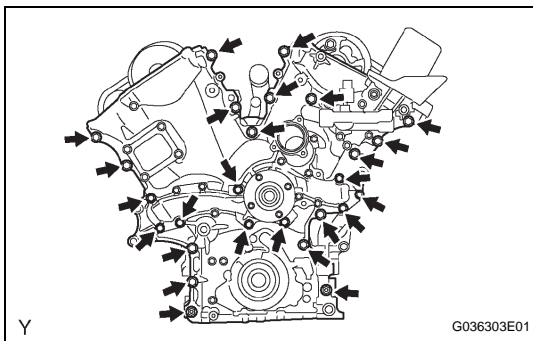

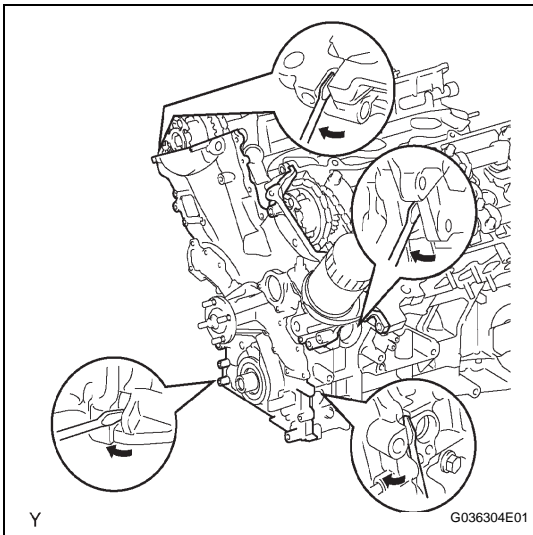

- (b) Remove the timing chain cover by prying between the timing chain cover and cylinder head or cylinder block with a screwdriver.

**NOTICE:**

**Be careful not to damage the contact surfaces of the timing chain cover, cylinder block and cylinder head.**

- (c) Remove the O-ring from the LH cylinder head.

**22. REMOVE TIMING GEAR CASE OR TIMING CHAIN CASE OIL SEAL (See page EM-236)**

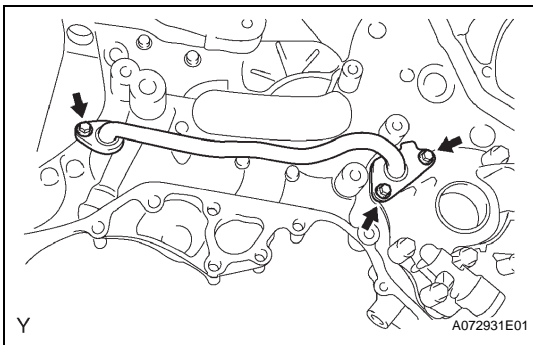

**DISASSEMBLY**

**1. REMOVE OIL PUMP COVER**

- (a) Remove the 3 bolts, then remove the oil pipe.
- (b) Remove the 2 O-rings.

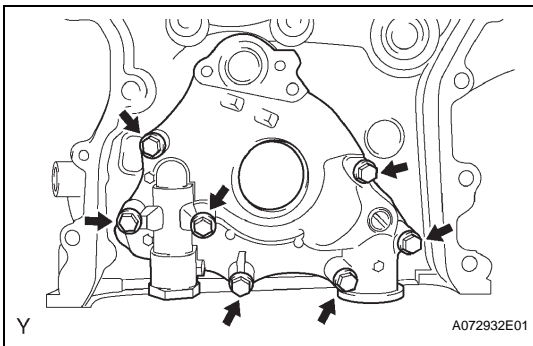

- (c) Remove the 7 bolts, then remove the oil pump cover, drive rotor and driven rotor.

**2. REMOVE OIL PUMP RELIEF VALVE**

- (a) Remove the relief valve plug.
- (b) Remove the relief valve spring and relief valve.

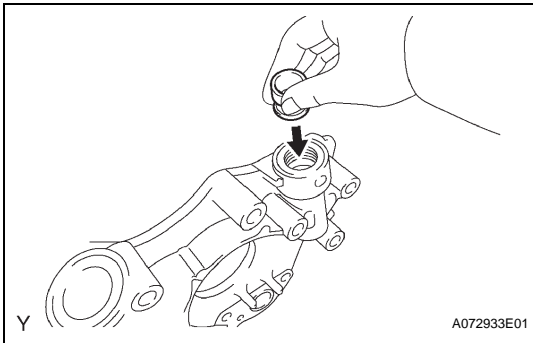

**INSPECTION**

**1. INSPECT OIL PUMP RELIEF VALVE**

- (a) Coat the valve with engine oil, then check that it falls smoothly into the valve hole by its own weight. If not, replace the relief valve. If necessary, replace the oil pump assembly.

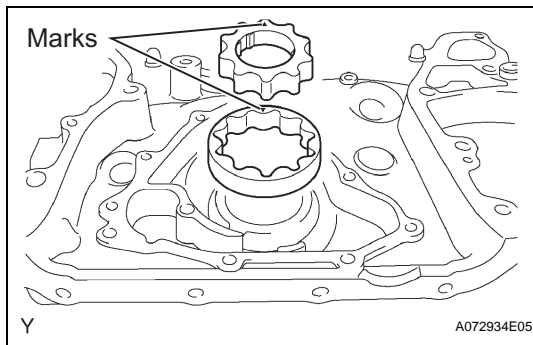

## 2. INSPECT OIL PUMP ROTOR SET

- (a) Place the drive and driven rotors into the timing chain cover with the marks facing upward.

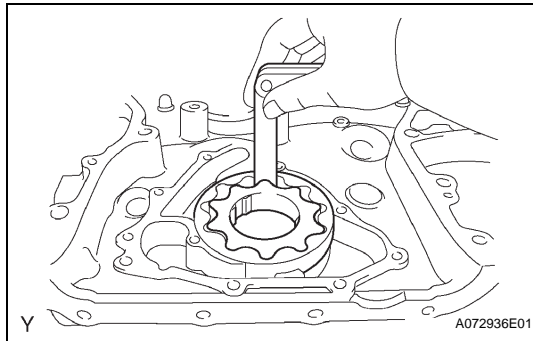

- (b) Check the rotor tip clearance.
- (1) Using a feeler gauge, measure the clearance between the drive and driven rotor tips.
- Standard clearance:**  
**0.06 to 0.16 mm (0.0024 to 0.0063 in.)**  
**Maximum tip clearance: 0.16 mm (0.0063 in.)**
- If the clearance is greater than the maximum, replace the drive and driven rotors together.

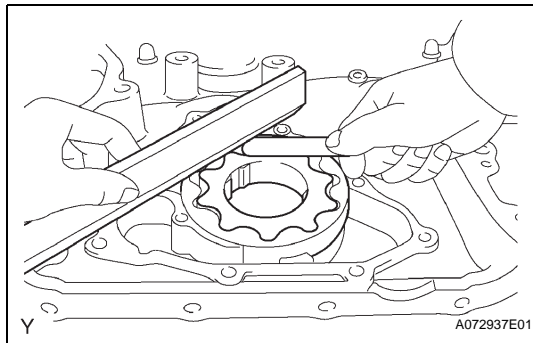

- (c) Check the rotor side clearance.
- (1) Using a feeler gauge and precision straight edge, measure the clearance between the rotors and precision straight edge.
- Standard clearance:**  
**0.03 to 0.09 mm (0.0012 to 0.0035 in.)**  
**Maximum side clearance: 0.09 mm (0.0035 in.)**
- If the clearance is greater than the maximum, replace the drive and driven rotors. If necessary, replace the timing chain cover assembly.

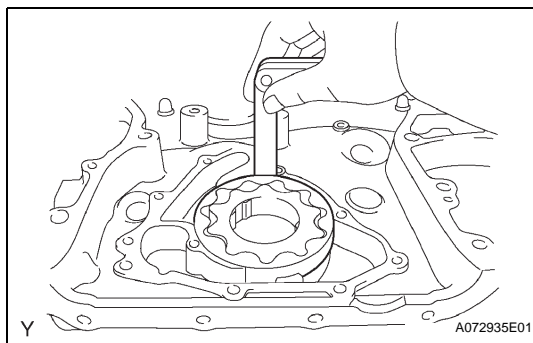

- (d) Check the rotor body clearance.
- (1) Using a feeler gauge, measure the clearance between the driven rotor and body.
- Standard clearance:**  
**0.250 to 0.325 mm (0.0098 to 0.0128 in.)**  
**Maximum body clearance: 0.325 mm (0.0128 in.)**
- If the clearance is greater than the maximum, replace the drive and driven rotors. If necessary, replace the timing chain cover assembly.