

REASSEMBLY

1. INSTALL STARTER ARMATURE ASSEMBLY

- (a) Apply grease to the bearings, and install it onto the starter yoke.

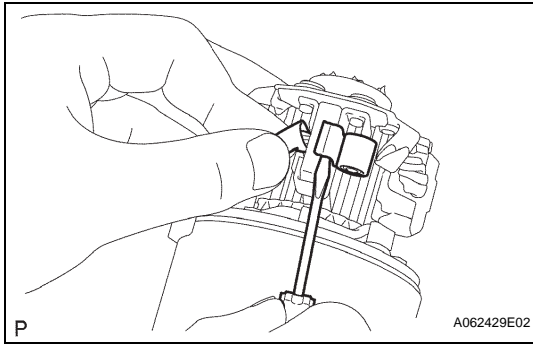

2. INSTALL STARTER BRUSH HOLDER ASSEMBLY

- (a) Place the brush holder on the armature.
- (b) Using a screwdriver, install the 4 brushes.
- (c) Install a new O-ring onto the groove of the field frame.

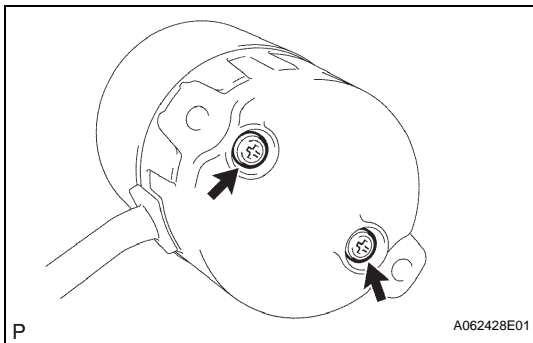

- (d) Install the end frame with the 2 screws.
Torque: 3.8 N*m (39 kgf*cm, 34 in.*lbf)

3. INSTALL MAGNET STARTER SWITCH ASSEMBLY

- (a) Apply grease to the steel ball, and install it onto the clutch shaft hole.

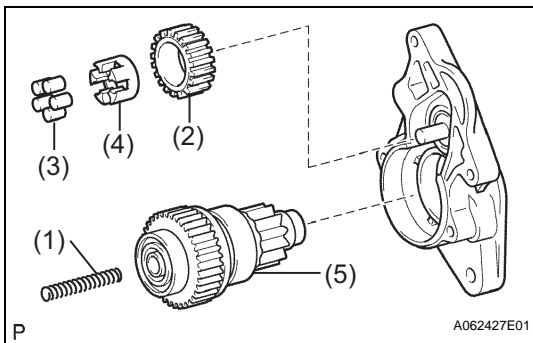

- (b) Apply grease to parts (2)- (5), and install all the parts below onto the starter drive housing.

(1)	Starter magnet switch return spring
(2)	Starter idle gear pinion
(3)	Starter idle gear clutch roller
(4)	Starter idle gear retainer
(5)	Starter clutch

- (c) Install the magnet starter switch with the 2 screws.
Torque: 9.3 N*m (95 kgf*cm, 82 in.*lbf)

4. INSTALL STARTER YOKE ASSEMBLY

- (a) Install a new O-ring onto the groove of the starter yoke.

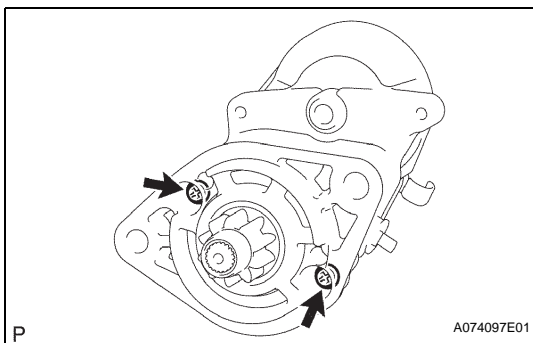

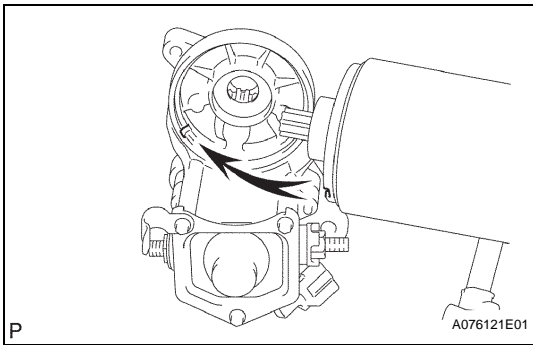

- (b) Align the key of the starter yoke with the groove of the magnet starter switch.

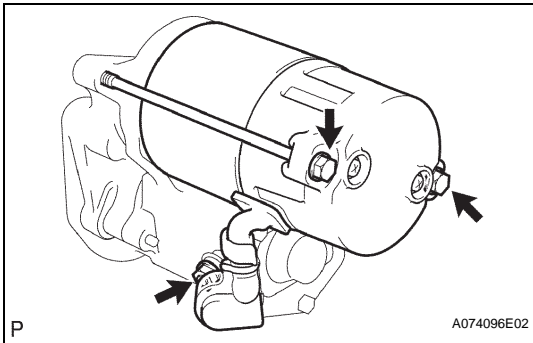

- (c) Install the starter yoke and armature with the 2 through bolts.
Torque: 9.3 N*m (95 kgf*cm, 82 in.*lbf)
- (d) Connect the lead wire to terminal C with the nut.
Torque: 5.9 N*m (60 kgf*cm, 52 in.*lbf)