

STARTER (for 2WD and Pre-Runner)

COMPONENTS

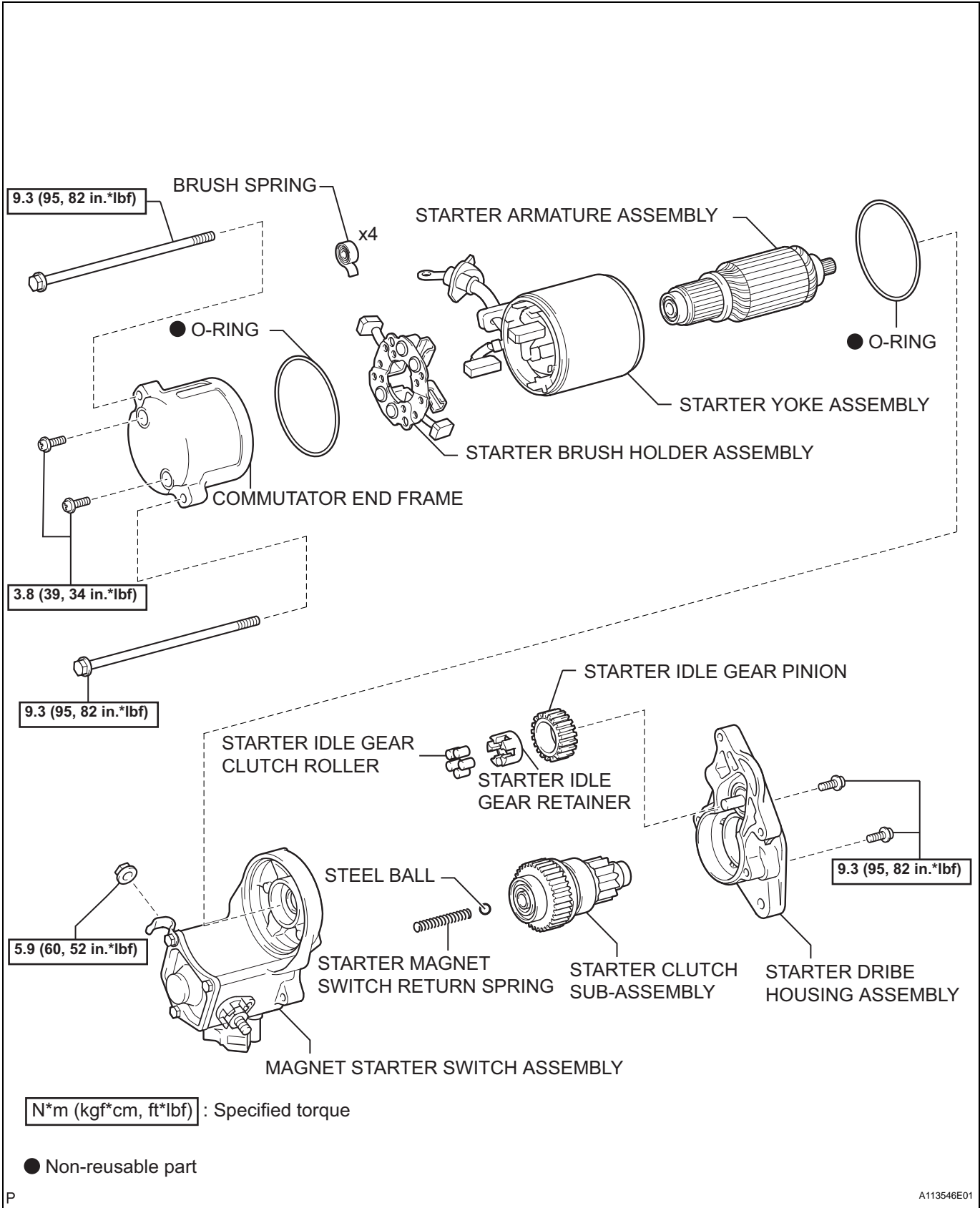

ST

REMOVAL

1. **DISCONNECT CABLE FROM NEGATIVE BATTERY TERMINAL**
2. **REMOVE NO.1 ENGINE UNDER COVER SUB-ASSEMBLY (for Off Road Package)**
 - (a) Remove the 4 bolts, then remove the engine under cover.
3. **REMOVE NO.2 MANIFOLD STAY**
 - (a) Remove the 3 bolts, then remove the manifold stay No. 2.
4. **SEPARATE WIRE HARNESS**
 - (a) Remove the bolt, then separate the earth wire harness from the cylinder block.
5. **REMOVE STARTER ASSEMBLY**
 - (a) Disconnect the terminal 50 connector from the starter assy.
 - (b) Remove the nut, then disconnect the wire harness from terminal 30.
 - (c) Remove the 2 bolts, then remove the starter assembly.

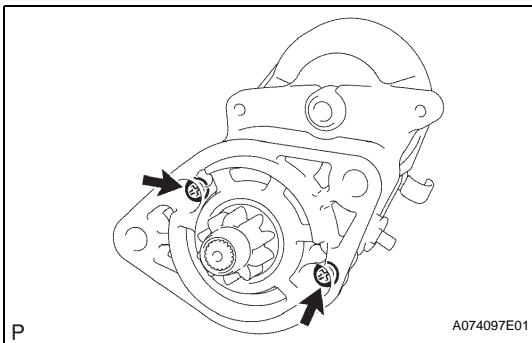
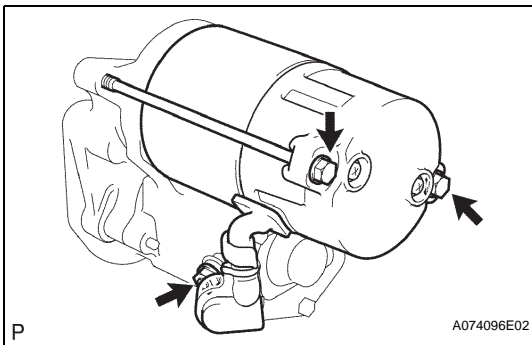
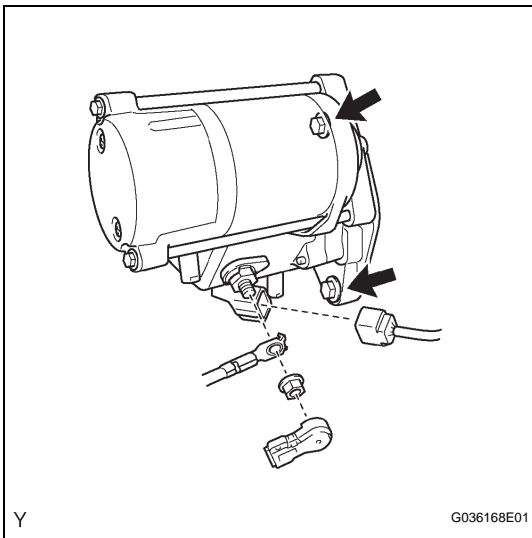

DISASSEMBLY

1. **REMOVE STARTER YOKE ASSEMBLY**
 - (a) Remove the nut, then disconnect the lead wire from terminal C.
 - (b) Remove the 2 through bolts.
 - (c) Pull the starter yoke and the armature out together.
 - (d) Remove the O-ring from the starter yoke.
2. **REMOVE MAGNET STARTER SWITCH ASSEMBLY**
 - (a) Remove the 2 screws, then remove the magnet starter switch.

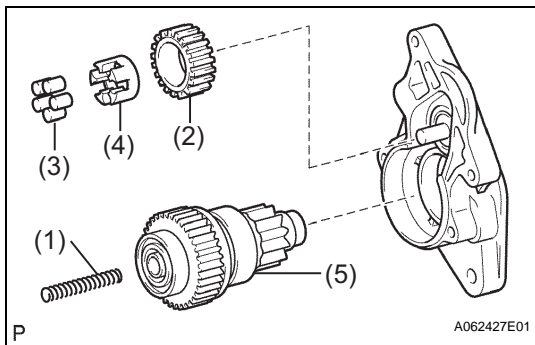

(b) Remove these parts from the starter drive housing.

(1)	Starter magnet switch return spring
(2)	Starter idle gear pinion
(3)	Starter idle gear clutch roller
(4)	Starter idle gear retainer
(5)	Starter clutch

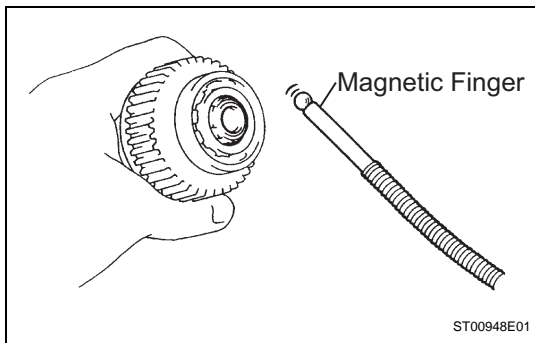

(c) Using a magnetic finger, remove the steel ball from the clutch shaft hole.

3. REMOVE STARTER BRUSH HOLDER ASSEMBLY

- Remove the 2 screws, then remove the end frame from the starter yoke.
- Remove the O-ring from the starter yoke.

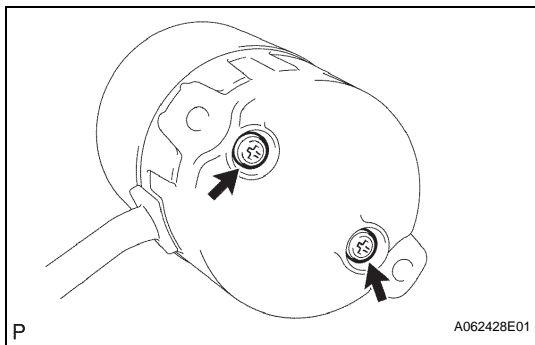

- Using a screwdriver, hold the spring back and disconnect the 4 brushes from the brush holder.
- Remove the brush holder from the armature.

4. REMOVE STARTER ARMATURE ASSEMBLY

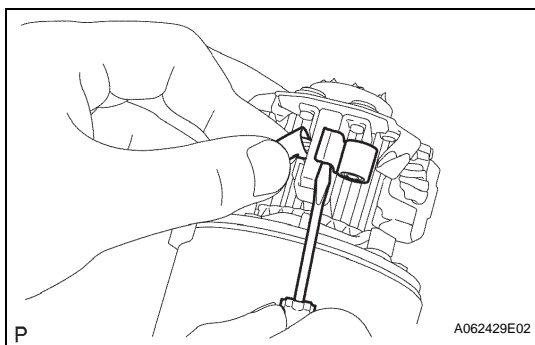

INSPECTION

1. INSPECT STARTER ARMATURE ASSEMBLY

- Check the commutator for an open circuit.
 - Using an ohmmeter, measure the resistance between the segments of the commutator.

Standard:

1 Ω or lower

If the result is not as specified, replace the starter armature.

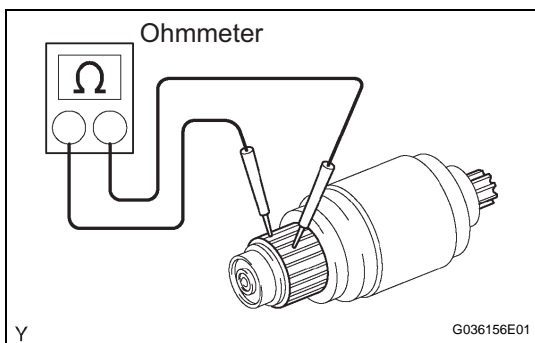

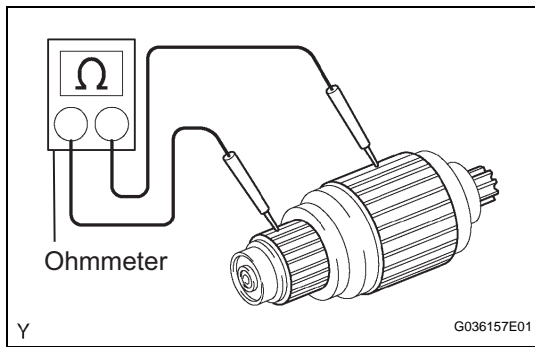

- (b) Check the commutator for ground.
 (1) Using an ohmmeter, measure the resistance between the commutator and armature coil core.

Standard:**10 k Ω or higher**

If the result is not as specified, replace the starter armature.

- (c) Check whether the commutator surface is dirty or burnt.
 If necessary, clean it with sandpaper (No. 400) or a lathe.

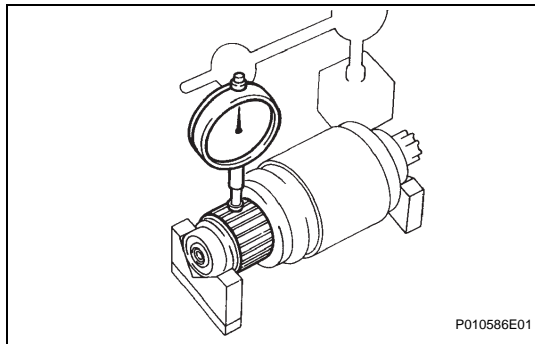

- (d) Check the commutator for runout.
 (1) Place the commutator on V-blocks.
 (2) Using a dial gauge, measure the runout.

Maximum runout:**0.05 mm (0.0020 in.)**

If the runout is greater than the maximum, correct it on a lathe.

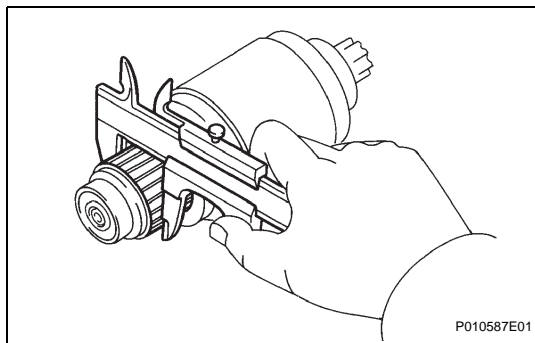

- (e) Using vernier calipers, measure the commutator diameter.

Standard diameter:**35.0 mm (1.378 in.)****Minimum diameter:****34.0 mm (1.339 in.)**

If the diameter is less than the minimum, replace the armature.

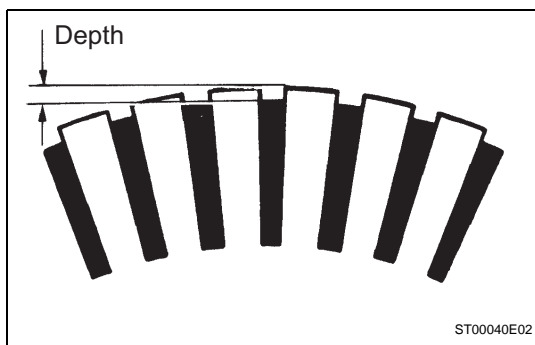

- (f) Check that the undercut portion between the segments is free of foreign objects. Measure its depth.

Standard undercut depth:**0.7 mm (0.028 in.)****Minimum undercut depth:****0.2 mm (0.008 in.)**

If the undercut depth is less than the minimum, correct it with a hacksaw blade.

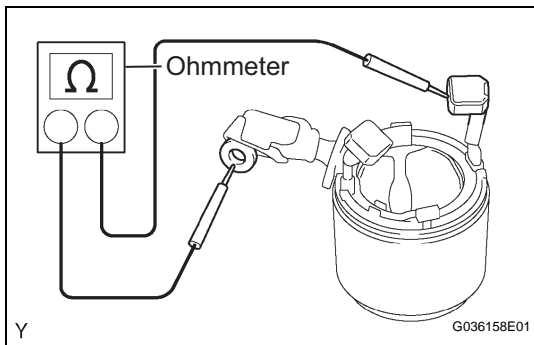

2. INSPECT STARTER YOKE ASSEMBLY

(a) Check the starter yoke for an open circuit.

- (1) Using an ohmmeter, measure the resistance between the lead wire and brushes.

Standard:

1 Ω or lower

If the result is not as specified, replace the starter yoke.

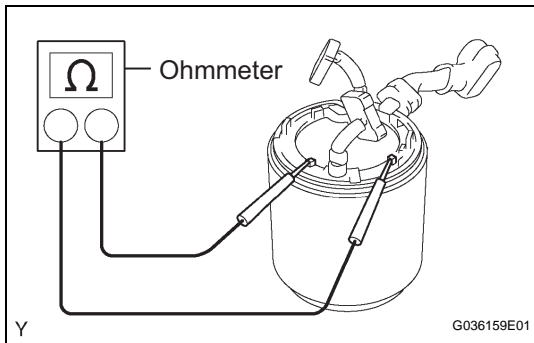

(b) Check the shunt coil for an open circuit.

- (1) Using an ohmmeter, measure the resistance between shunt coil terminals A and B.

Standard:

1.5 to 1.9 Ω at 20°C (68°F)

If the result is not as specified, replace the starter yoke.

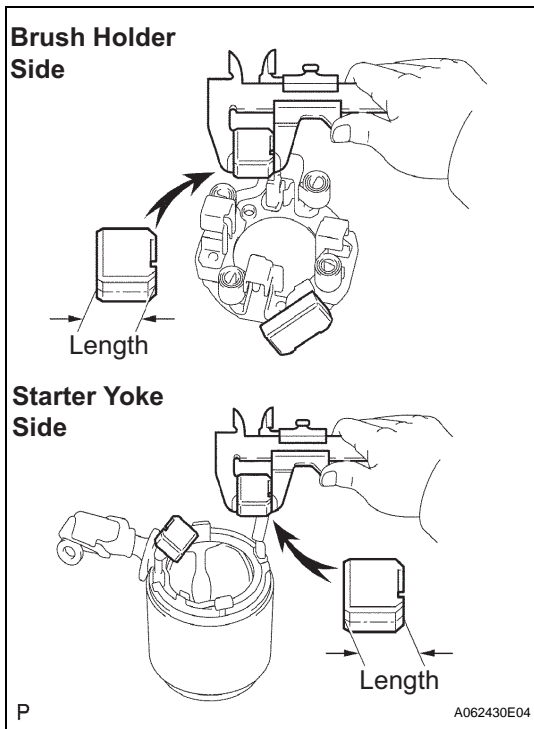

3. INSPECT BRUSH

(a) Check the brush length.

- (1) Using vernier calipers, measure the brush length.

Standard length:

15.0 mm (0.591 in.)

Minimum length:

9.0 mm (0.354 in.)

If the length is less than the minimum, replace the brush holder and starter yoke.

ST

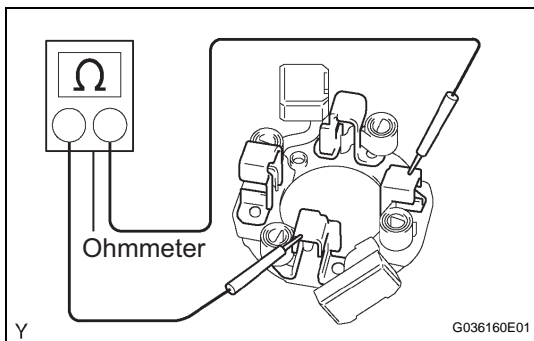

4. INSPECT STARTER BRUSH HOLDER ASSEMBLY

(a) Check the brush holder insulation.

- (1) Using an ohmmeter, measure the resistance between the positive (+) and negative (-) brush holders.

Standard:

10 k Ω or higher

If the result is not as specified, replace the brush holder.

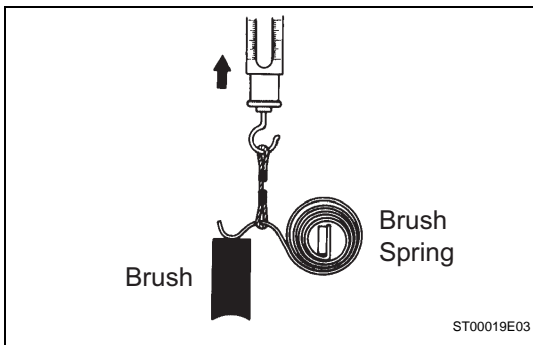

- (b) Check the brush spring load.
- (1) Take the pull scale reading as soon as the brush spring separates from the brush.
- Standard spring load:**
21.5 to 27.5 N (2.2 to 2.8 kgf, 4.8 to 6.2 lbf)
- Minimum spring load:**
12.7 N (1.3 kgf, 2.9 lbf)
- If the spring load is less than the minimum, replace the brush holder.

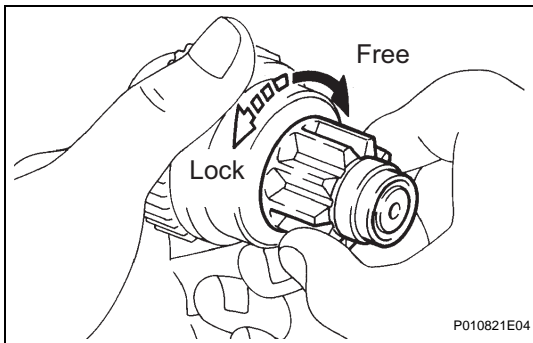

5. INSPECT STARTER CLUTCH SUB-ASSEMBLY

- (a) Check the clutch pinion gear.
- (1) Hold the starter clutch, rotate the pinion gear clockwise and check that it turns freely.
 - (2) Try to rotate the pinion gear counterclockwise and check that it locks.
- If necessary, replace the starter clutch.

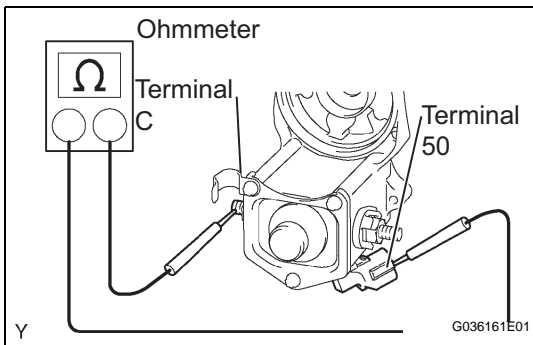

6. INSPECT MAGNET STARTER SWITCH ASSEMBLY

- (a) Check the pull-in coil for an open circuit.
- (1) Using an ohmmeter, measure the resistance between terminals 50 and C.
- Standard:**
1 Ω or lower
- If the result is not as specified, replace the magnet starter switch.

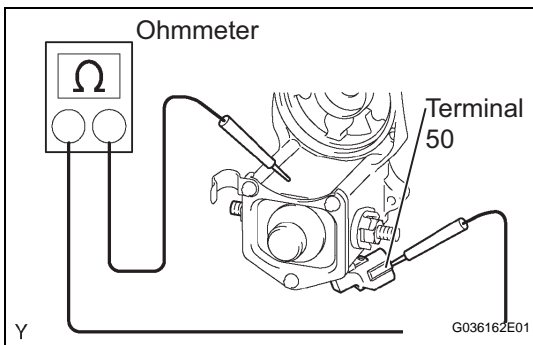

- (b) Check the holding coil for an open circuit.
- (1) Using an ohmmeter, measure the resistance between terminal 50 and the switch body.
- Standard:**
2 Ω or lower
- If the result is not as specified, replace the magnet starter switch.