

# SYSTEM DIAGRAM

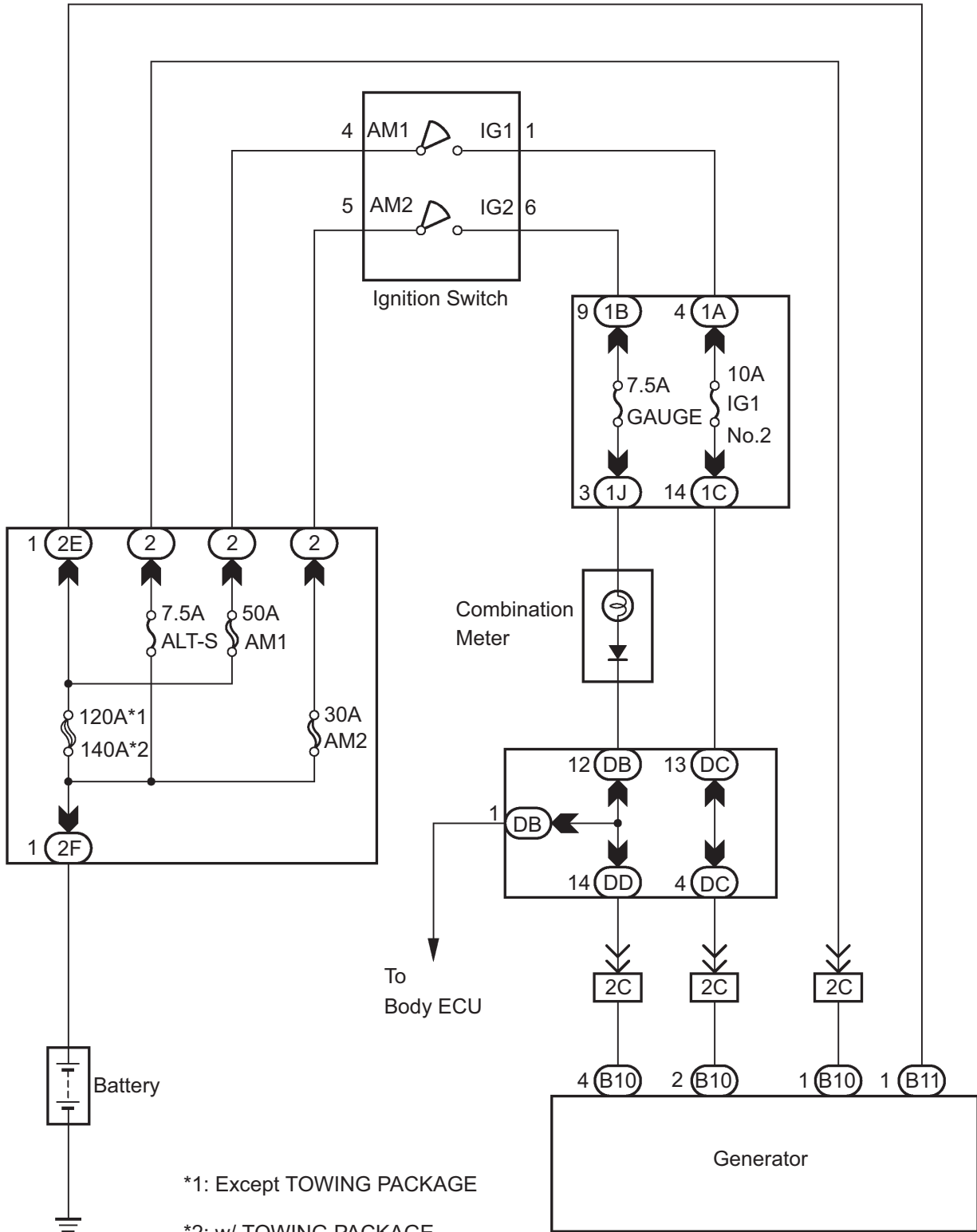

\*1: Except TOWING PACKAGE

\*2: w/ TOWING PACKAGE

## ON-VEHICLE INSPECTION

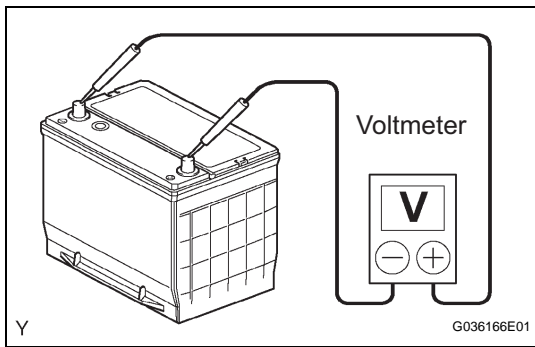

### 1. INSPECT BATTERY (for Maintenance Free Battery)

- (a) Check the voltage.
  - (1) If it has been less than 20 minutes since you stopped driving the vehicle or since the engine was stopped, turn the ignition switch and electrical systems (headlight, blower motor, rear defogger etc.) to the ON position for 60 seconds. This will remove the surface charge on the battery.
  - (2) Turn the ignition switch to OFF.
  - (3) Turn the electrical systems to OFF.
  - (4) Using a voltmeter, measure the battery voltage between the negative (-) and positive (+) terminals of the battery.

**Standard:**

**12.6 to 12.9 V at 20°C(68°F)**

If the result is not as specified, replace the battery.

- (b) Check the indicator is as shown in the illustration.

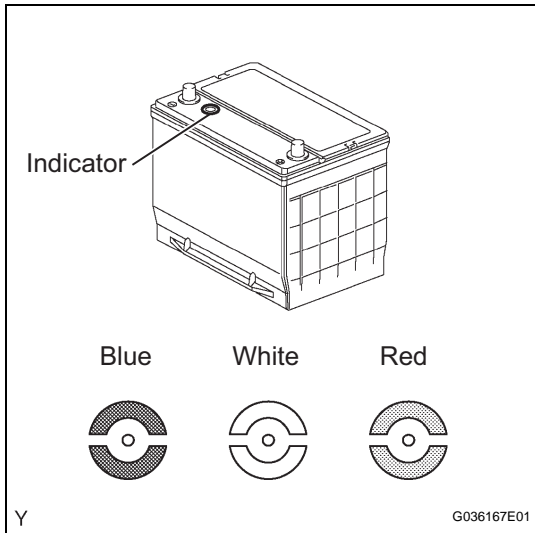

Indicator Color	Condition
Blue	Ready
White	Charging Necessary
Red	Have battery checked by your Toyota dealer

### 2. INSPECT BATTERY TERMINALS, FUSIBLE LINK AND FUSES

- (a) Visually check the battery terminals.
  - (1) Check that the battery terminals are not loose or corroded.
- (b) Visually check the fusible link and fuses.
  - (1) Check that there is continuity between the fusible links, high current fuses and regular fuses.

### 3. INSPECT DRIVE BELT

- (a) Visually check the belt for excessive wear, frayed cords, etc..
  - If any defects are found, replace the V-ribbed belt.
  - Cracks on the rib side of the belt are considered acceptable. If the belt has chunks missing from the ribs, it should be replaced.

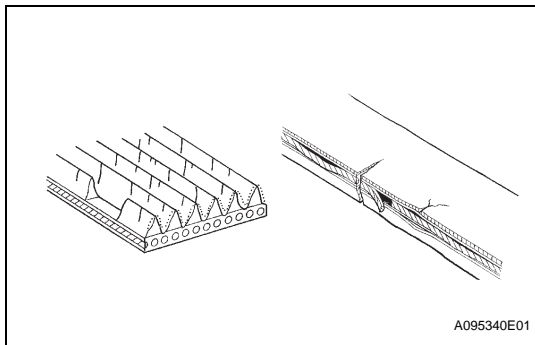

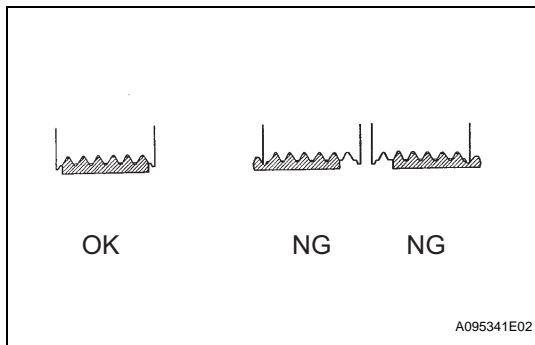

- (b) Check that the belt fits properly in the ribbed grooves. Confirm by hand that the belt has not slipped out of the grooves on the bottom of the pulley.

#### 4. INSPECT GENERATOR WIRING

- (a) Visually check the generator wiring.  
 (1) Check that the wiring is in good condition.

#### 5. INSPECT ABNORMAL NOISES

- (a) Listen for abnormal noises from the generator.  
 (1) Check that no abnormal noises are heard from the generator while the engine is running.

#### 6. INSPECT CHARGING WARNING LIGHT CIRCUIT

- (a) Turn the ignition switch to ON. Check that the charge warning light comes on.  
 (b) Start the engine and check that the light goes off. If the light does not operate as specified, troubleshoot the charge warning light circuit.

#### 7. INSPECT CHARGING CIRCUIT WITHOUT LOAD

- (a) If a tester is not available, connect a voltmeter and ammeter to the charging circuit as follows.  
 (1) Disconnect the wire from terminal B of the generator, then connect it to the negative (-) lead of the ammeter.  
 (2) Connect the positive (+) lead of the ammeter to terminal B of the generator.  
 (3) Connect the positive (+) lead of the voltmeter to terminal B of the generator.  
 (4) Ground the negative (-) lead of the voltmeter.  
 (b) Check the charging circuit.  
 (1) Maintain the engine speed at 2,000 rpm and check the reading on the ammeter and voltmeter.

##### Standard:

**10 A or less for amperage**

**13.2 to 14.8 V for voltage**

#### 8. INSPECT CHARGING CIRCUIT WITH LOAD

- (a) With the engine running at 2,000 rpm, turn the high beam headlights ON and turn the heater blower switch to the HI position.  
 (b) Check the reading on the ammeter.

##### Standard:

**30 A or more**

- If the ammeter reading is less than the standard amperage, repair the generator.
- If the battery is fully charged, the indication will sometimes be less than the standard amperage.

