

# PARK / NEUTRAL POSITION SWITCH

## REMOVAL

1. DISCONNECT CABLE FROM NEGATIVE BATTERY TERMINAL
2. DISCONNECT PARK/NEUTRAL POSITION SWITCH CONNECTOR
3. REMOVE PARK/NEUTRAL POSITION SWITCH ASSEMBLY

- (a) Using a screwdriver, unstake the lock washer.
- (b) Remove the nut, lock washer and grommet.
- (c) Remove the bolt and park/neutral position switch.

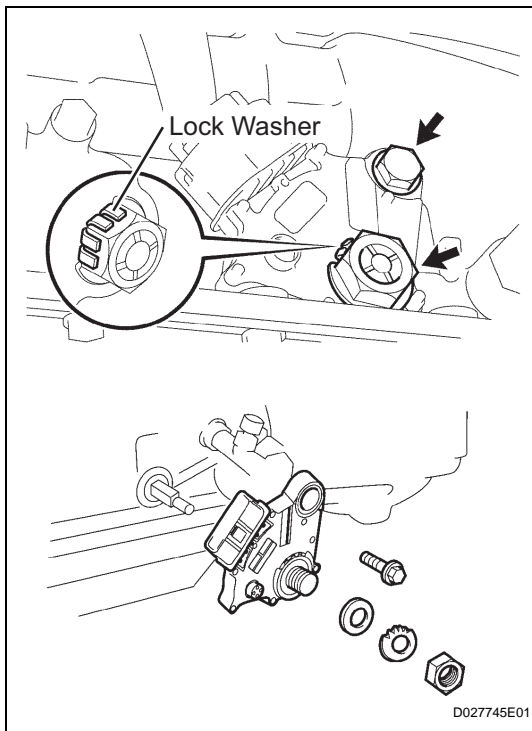

## ADJUSTMENT

### 1. INSPECT PARK/NEUTRAL POSITION SWITCH ASSEMBLY

- (a) Apply the parking brake and turn the ignition switch to ON.
- (b) Depress the brake pedal and check that the engine starts only when the shift lever is set in the N or P position and that it does not start in any other positions.
- (c) Check that the back-up light comes on and the reverse warning buzzer sounds only when the shift lever is set in the R position and not in other positions.

If any failure is found, check the park/neutral position switch for continuity.

### 2. ADJUST PARK/NEUTRAL POSITION SWITCH ASSEMBLY

- (a) Loosen the bolt of the park/neutral position switch and set the shift lever to the N position.
- (b) Align the groove and the neutral basic line.
- (c) Hold the switch in position and tighten the bolt.  
**Torque: 13 N\*m (130 kgf\*cm, 9 ft.\*lbf)**
- (d) After making an adjustment, perform the inspection described in step 1.

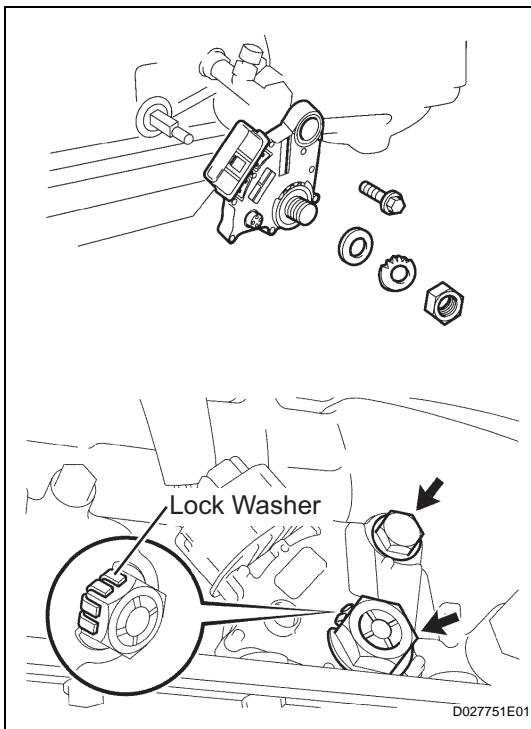
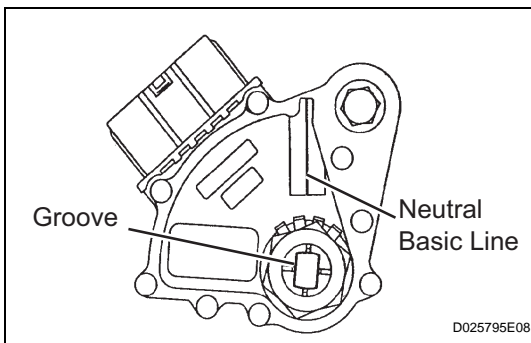

## INSTALLATION

### 1. INSTALL PARK/NEUTRAL POSITION SWITCH ASSEMBLY

- (a) Install the park/neutral position switch onto the manual valve lever shaft and provisionally tighten the adjusting bolt.

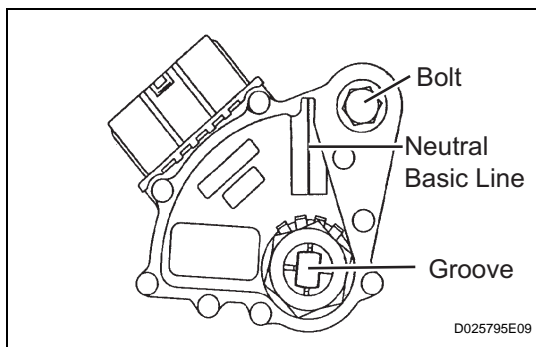

- (b) Install the grommet, a new lock washer and the nut.  
**Torque: 6.9 N\*m (70 kgf\*cm, 61 in.\*lbf)**
- (c) Install the manual valve lever shaft onto the groove and turn it 2 notches counterclockwise to the neutral position.
- (d) Align the neutral basic line with the switch groove and tighten the adjusting bolt.  
**Torque: 13 N\*m (130 kgf\*cm, 9 ft.\*lbf)**
- (e) Bend the tabs of the lock washer.  
HINT:  
Bend at least 2 of the lock washer tabs.

**2. CONNECT PARK/NEUTRAL POSITION SWITCH CONNECTOR**

**3. CONNECT CABLE TO NEGATIVE BATTERY TERMINAL**

**Torque: 3.9 N\*m (40 kgf\*cm, 35 in.\*lbf)**

**4. INSPECT PARK/NEUTRAL POSITION SWITCH ASSEMBLY (See page [AT-92](#))**

**5. ADJUST PARK/NEUTRAL POSITION SWITCH ASSEMBLY (See page [AT-92](#))**

**6. ADJUST SHIFT LEVER POSITION (See page [AT-105](#))**

**7. INSPECT SHIFT LEVER POSITION (See page [AT-105](#))**