

AUTOMATIC TRANSMISSION ASSEMBLY

COMPONENTS

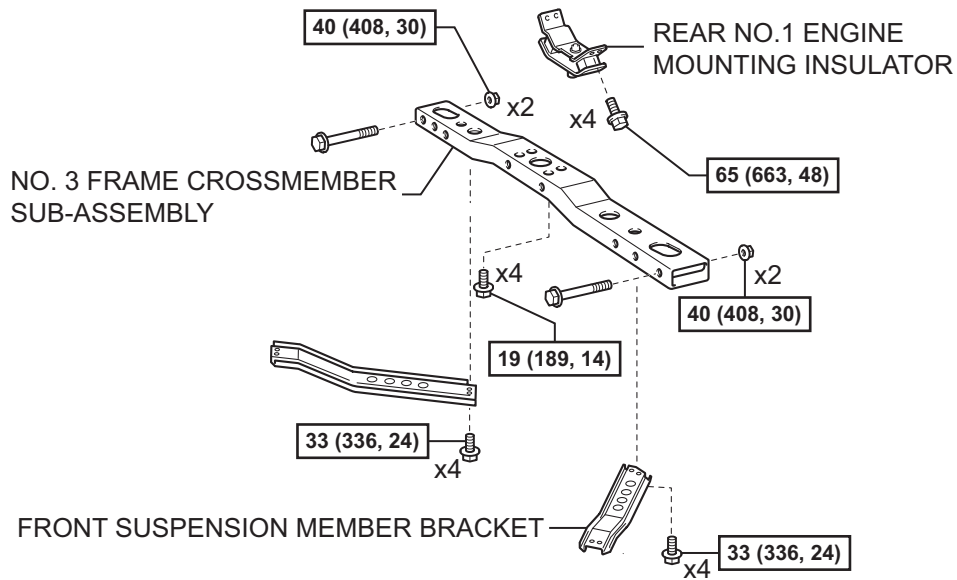
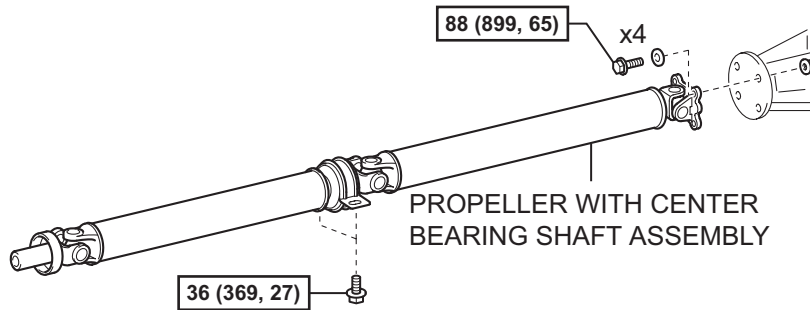
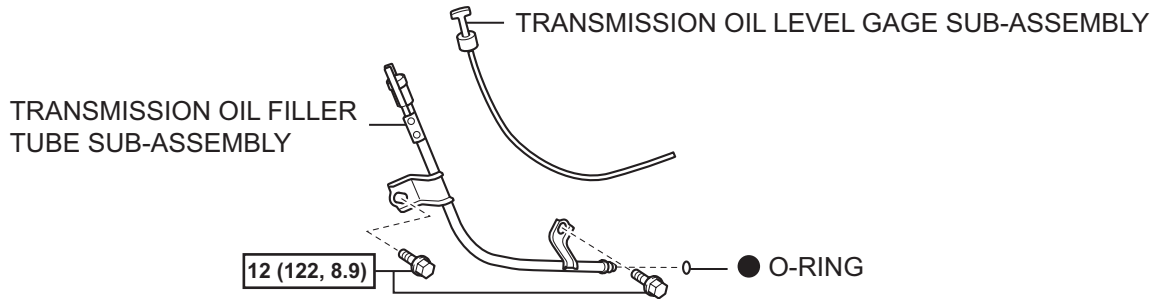

N*m (kgf*cm, ft*lbf) : Specified torque

● Non-reusable part

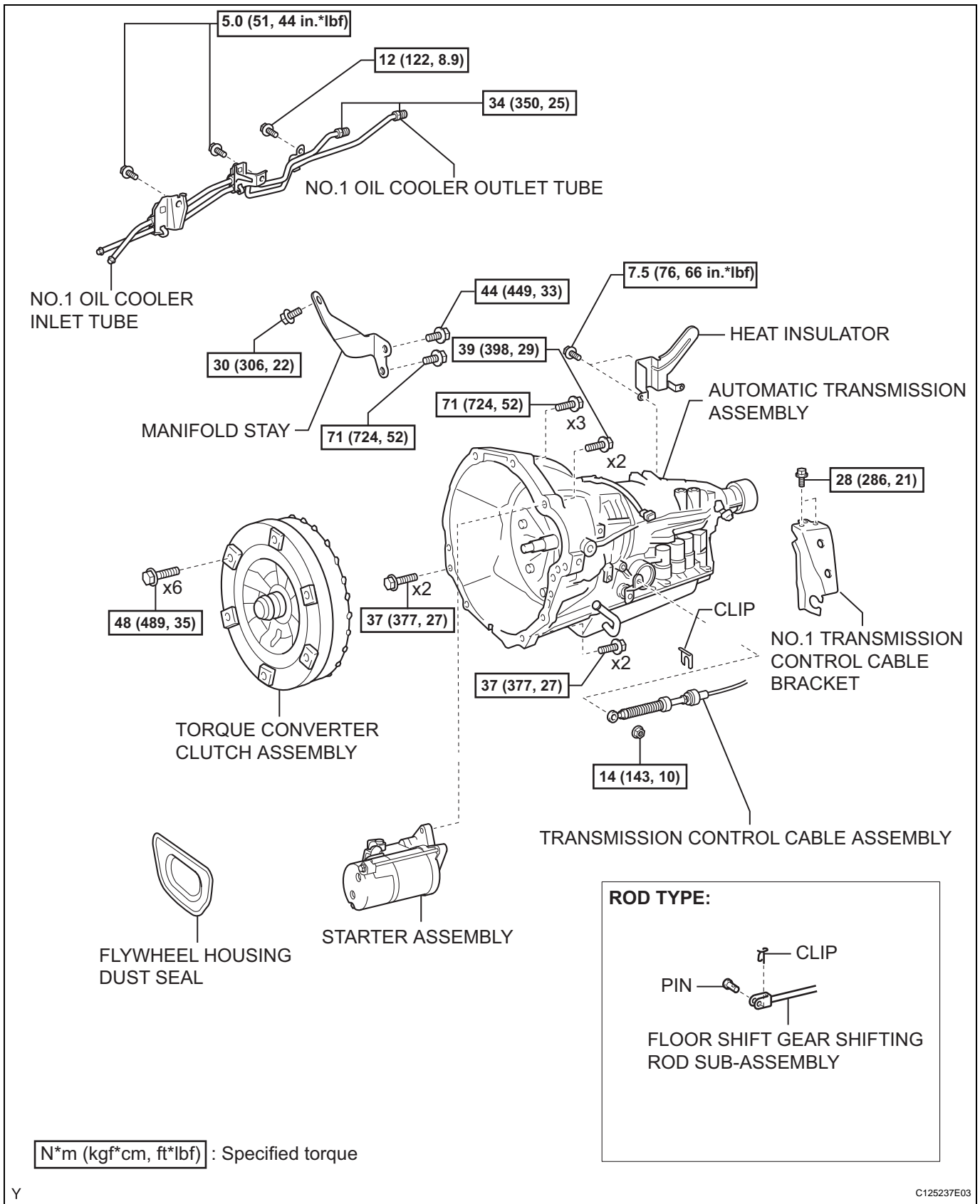

Y

C125237E03