

# TRANSMISSION CONTROL CABLE

## REMOVAL

1. REMOVE CONSOLE UPPER REAR PANEL SUB-ASSEMBLY (See page [IP-9](#))
2. REMOVE CONSOLE BOX ASSEMBLY REAR (See page [IP-10](#))
3. REMOVE INSTRUMENT PANEL CUP HOLDER TRAY (See page [IP-10](#))
4. REMOVE CONSOLE BOX FRONT (See page [IP-10](#))
5. REMOVE VOLTAGE INVERTER ASSEMBLY (w/ Voltage Inverter) (See page [AV-104](#))
6. REMOVE TRANSMISSION CONTROL CABLE ASSEMBLY

- (a) Disconnect the transmission control cable assembly from the shift lever assembly.
- (b) Remove the clip and disconnect the transmission control cable.

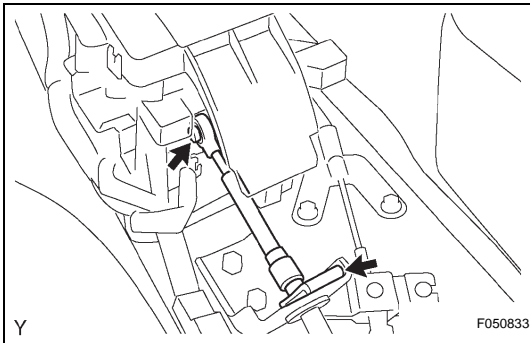

- (c) Remove the 2 nuts and disconnect the transmission control cable assembly from the body.

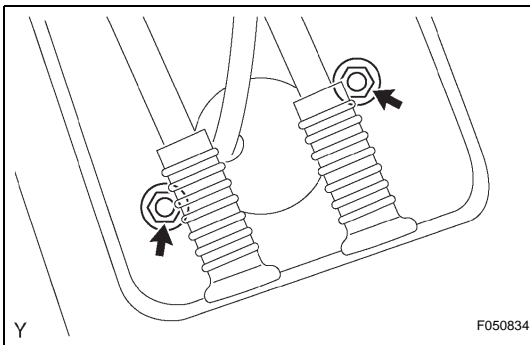

- (d) Remove the nut and disconnect the transmission control cable assembly from the body.

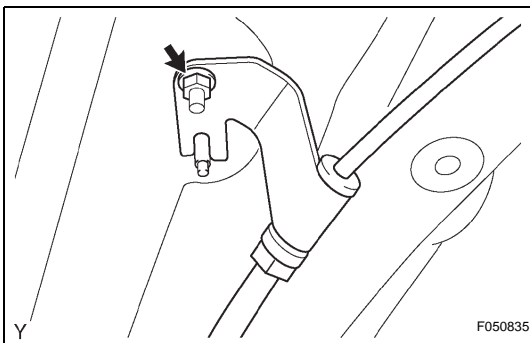

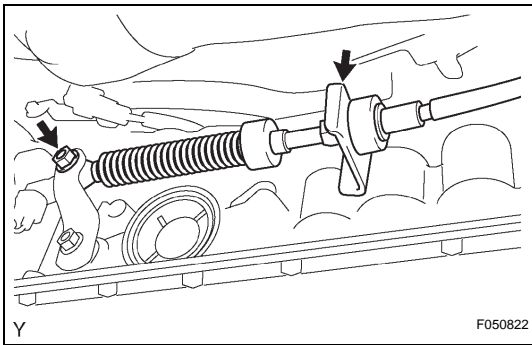

- (e) Remove the clip and transmission control cable bracket.
- (f) Remove the nut and transmission control cable assembly.

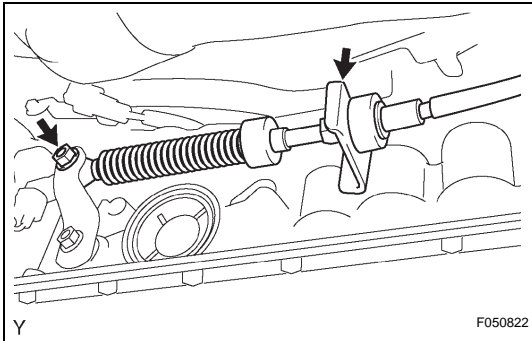

## INSTALLATION

### 1. INSTALL TRANSMISSION CONTROL CABLE ASSEMBLY

- (a) Install the transmission control cable assembly with the nut.  
**Torque: 14 N\*m (143 kgf\*cm, 10 ft.\*lbf)**
- (b) Install the transmission control cable bracket and lock plate.

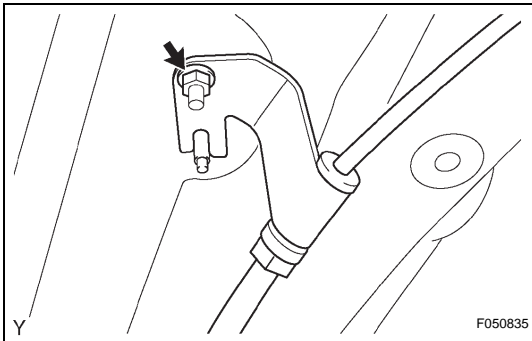

- (c) Connect the transmission control cable with the nut to the body.  
**Torque: 5.5 N\*m (56 kgf\*cm, 49 in.\*lbf)**

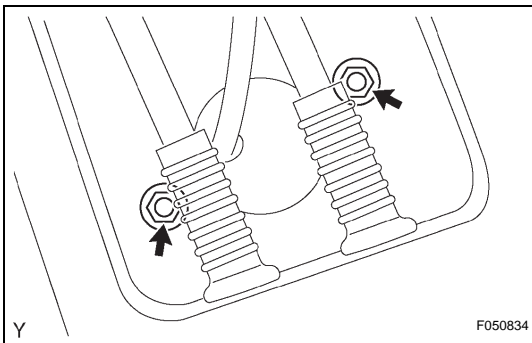

- (d) Connect the transmission control cable with the 2 nuts to the body.  
**Torque: 5.5 N\*m (56 kgf\*cm, 49 in.\*lbf)**

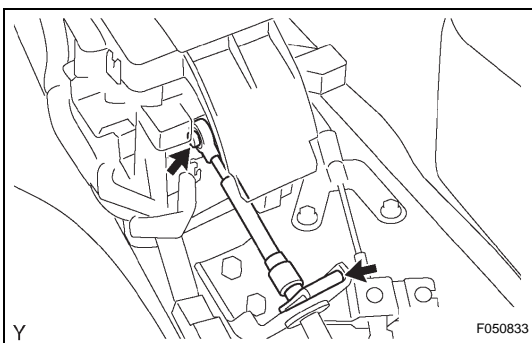

- (e) Connect the transmission control cable with the lock plate to the floor shift assembly.
- (f) Install the transmission control cable onto the floor shift assembly.

### 2. INSTALL VOLTAGE INVERTER ASSEMBLY (w/ Voltage Inverter) (See page [AV-105](#))

### 3. INSTALL CONSOLE BOX FRONT (See page [IP-24](#))

### 4. INSTALL INSTRUMENT PANEL CUP HOLDER TRAY (See page [IP-24](#))

5. **INSTALL CONSOLE BOX ASSEMBLY REAR** (See page [IP-24](#))
6. **INSTALL CONSOLE UPPER REAR PANEL SUB-ASSEMBLY** (See page [IP-25](#))
7. **ADJUST SHIFT LEVER POSITION** (See page [AT-105](#))
8. **INSPECT SHIFT LEVER POSITION** (See page [AT-105](#))