

DTC	P0710	Transmission Fluid Temperature Sensor "A" Circuit
DTC	P0712	Transmission Fluid Temperature Sensor "A" Circuit Low Input
DTC	P0713	Transmission Fluid Temperature Sensor "A" Circuit High Input

DESCRIPTION

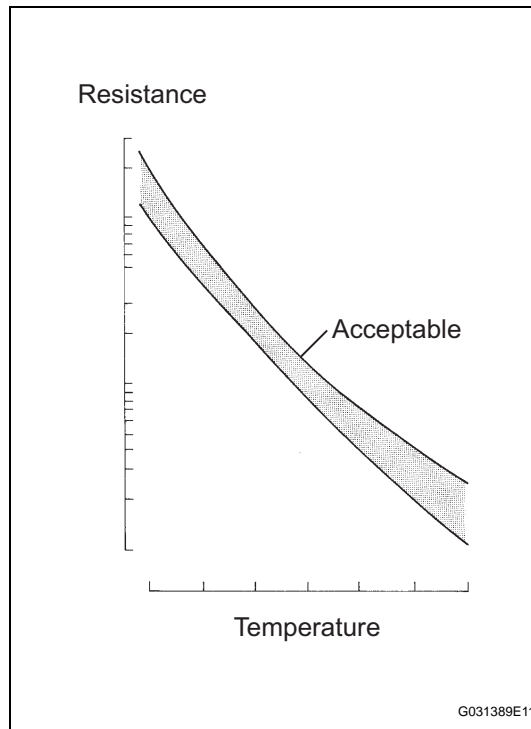

The ATF (Automatic Transmission Fluid) temperature sensor converts the fluid temperature into a resistance value which is input into the ECM.

The ECM applies a voltage to the temperature sensor through ECM terminal THO1.

The sensor resistance changes with the transmission fluid temperature. As the temperature becomes higher, the sensor resistance decreases.

One terminal of the sensor is grounded so that the sensor resistance and the voltage decrease as the temperature becomes higher.

The ECM calculates the fluid temperature based on the voltage signal.

DTC No.	DTC Detection Conditions	Trouble Areas
P0710	(a) and (b) are detected momentarily within 0.5 seconds when neither P0712 nor P0713 is detected (1-trip detection logic) (a) No. 1 ATF temperature sensor resistance is less than 79 Ω. (b) No. 1 ATF temperature sensor resistance is more than 156 kΩ. HINT: Within 0.5 seconds, the malfunction changes from (a) to (b) or from (b) to (a)	<ul style="list-style-type: none"> • Open or short in No. 1 ATF temperature sensor circuit • Transmission wire (No. 1 ATF temperature sensor) • ECM

DTC No.	DTC Detection Conditions	Trouble Areas
P0712	No. 1 ATF temperature sensor resistance is less than 79 Ω for 0.5 seconds or more (1-trip detection logic)	<ul style="list-style-type: none"> Short in No. 1 ATF temperature sensor circuit Transmission wire (No. 1 ATF temperature sensor) ECM
P0713	No. 1 ATF temperature sensor resistance is more than 156 k Ω for 0.5 seconds or more 15 minutes or more after starting engine (1-trip detection logic)	<ul style="list-style-type: none"> Open in No. 1 ATF temperature sensor circuit Transmission wire (No. 1 ATF temperature sensor) ECM

MONITOR DESCRIPTION

These DTCs indicate an open or short in the Automatic Transmission Fluid (ATF) temperature sensor circuit.

The ATF temperature sensor converts ATF temperature to an electrical resistance value. Based on the resistance, the ECM determines the ATF temperature, and detects any open or short malfunctions in the ATF temperature circuit. If the resistance value of the ATF temperature is less than 79 Ω *1 or more than 156 k Ω *2, the ECM interprets this as a fault in the ATF sensor or its wiring. The ECM turns on the MIL and stores a DTC.

*1: 150°C (302°F) or more is indicated regardless of the actual ATF temperature.

*2: -40°C (-40°F) is indicated regardless of the actual ATF temperature.

HINT:

The ATF temperature can be checked on the intelligent tester display.

MONITOR STRATEGY

Related DTCs	P0710: ATF temperature sensor/Range check (Fluttering) P0712: ATF temperature sensor/Range check (Low resistance) P0713: ATF temperature sensor/Range check (High resistance)
Required sensors/Components	ATF temperature sensor
Frequency of operation	Continuous
Duration	0.5 seconds
MIL operation	Immediate
Sequence of operation	None

TYPICAL ENABLING CONDITIONS

P0710: Range check (Fluttering)

The monitor will run whenever the following DTCs are not present.	None
The typical enabling condition is not available.	-

P0712: Range check (Low resistance)

The monitor will run whenever the following DTCs are not present.	None
The typical enabling condition is not available.	-

P0713: Range check (High resistance)

The monitor will run whenever the following DTCs are not present.	None
Time after engine start	15 minutes or more

TYPICAL MALFUNCTION THRESHOLDS

P0710: Range check (Fluttering)

ATF temperature sensor resistance	Less than 79 Ω or More than 156 k Ω
-----------------------------------	---

P0712: Range check (Low resistance)

ATF temperature sensor resistance	Less than 79 Ω
-----------------------------------	-----------------------

P0713: Range check (High resistance)

ATF temperature sensor resistance	More than 156 kΩ
-----------------------------------	------------------

COMPONENT OPERATING RANGE

ATF temperature sensor	Atmospheric temperature up to approximately 130°C (266°F)
------------------------	---

WIRING DIAGRAM

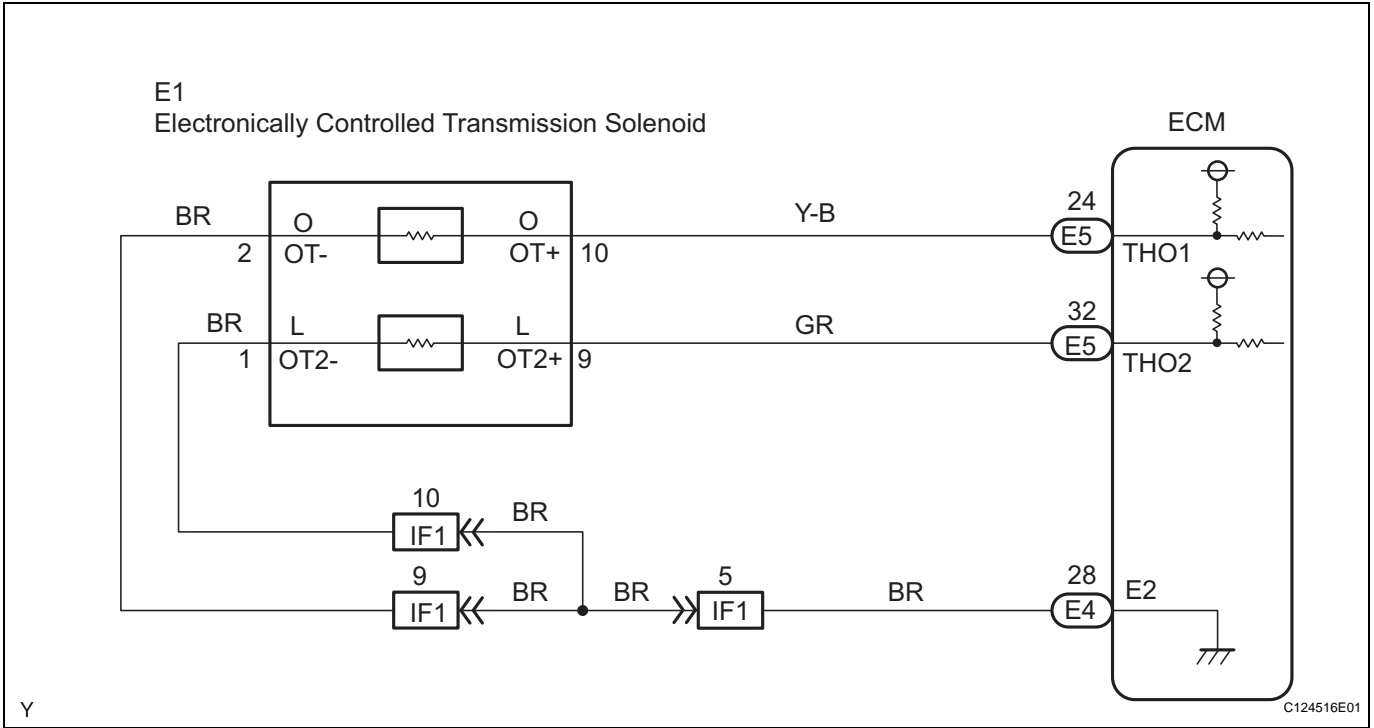

HINT:

According to the DATA LIST displayed on the intelligent tester, you can read the values of components, such as the switches, sensors and actuators, without removing any parts. Reading the DATA LIST as a first step of troubleshooting is one method of shortening labor time.

NOTICE:

In the table below, the values listed under "Normal Condition" are for reference only. Do not depend solely on these reference values when judging whether a part is faulty or not.

1. Warm up the engine.
2. Turn the ignition switch off.
3. Connect the intelligent tester together with the CAN VIM (controller area network vehicle interface module) to the DLC3.
4. Turn the ignition switch to the ON position.
5. Push the "ON" button of the tester.
6. Select the items "DIAGNOSIS/ ENHANCED OBD II/ DATA LIST/ A/T".
7. According to the display on the tester, read the "DATA LIST".

Item	Measurement Item/ Range (display)	Normal Condition
AT OIL TEMP1	No. 1 ATF Temperature Sensor Value/ min.: -40°C (-40°F) max.: 215°C (419°F)	<ul style="list-style-type: none"> • After Stall Test: Approximately 80°C (176°F) • Equal to ambient temperature during cold soak

HINT:

When DTC P0712 is output and intelligent tester reading is 150°C (302°F) or more, there is a short circuit. When DTC P0713 is output and intelligent tester reading is -40°C (-40°F), there is an open circuit. Measure the resistance between terminal THO1 (OT) and the body ground.

Temperature Displayed	Malfunction
-40°C (-40°F)	Open circuit
150°C (302°F) or more	Short circuit

HINT:

If a circuit related to the ATF temperature sensor becomes open, P0713 is immediately set (in 0.5 seconds). When P0713 is set, P0711 cannot be detected.

It is not necessary to inspect the circuit when P0711 is set.

1 INSPECT TRANSMISSION WIRE (ATF TEMPERATURE SENSOR)

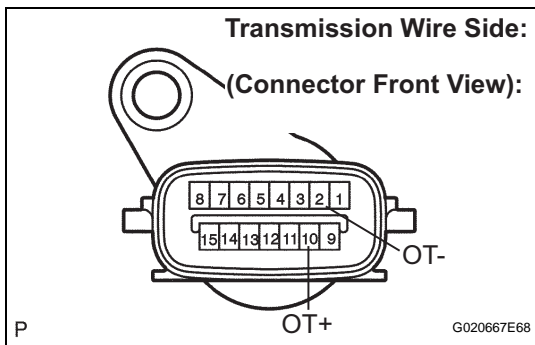

- (a) Disconnect the transmission wire connector from the transmission.
- (b) Measure the resistance.

Standard resistance

Tester Connection	Specified Condition
2 (OT-) - 10 (OT+)	79 Ω to 156 kΩ

- (c) Measure the resistance.

Standard resistance (Check for short)

Tester Connection	Specified Condition
2 (OT-) - Body ground	10 kΩ or higher
10 (OT+) - Body ground	10 kΩ or higher

HINT:

If the resistance is outside the specified range at either of the ATF temperatures shown in the table below, the driveability of the vehicle may decrease.

ATF Temperature	Specified Condition
20°C (68°F)	3 to 4 kΩ
110°C (230°F)	0.22 to 0.28 kΩ

NG

REPAIR OR REPLACE TRANSMISSION WIRE

OK

2 CHECK HARNESS AND CONNECTOR (TRANSMISSION WIRE - ECM)

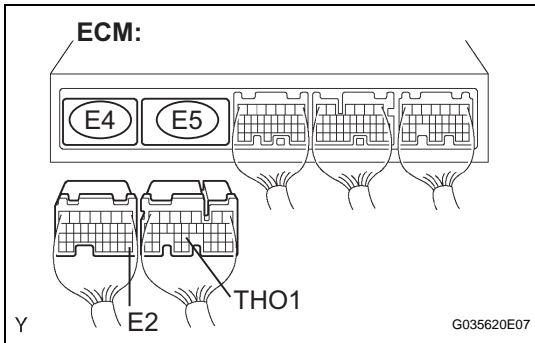

- (a) Connect the transmission wire connector to the transmission.
- (b) Disconnect the ECM connectors.
- (c) Measure the resistance.

Standard resistance

Tester Connection	Specified Condition
E5-24 (THO1) - E4-28 (E2)	79 Ω to 156 kΩ

- (d) Measure the resistance.

Standard resistance (Check for short)

Tester Connection	Specified Condition
E5-24 (THO1) - Body ground	10 kΩ or higher
E4-28 (E2) - Body ground	10 kΩ or higher

NG **REPAIR OR REPLACE HARNESS OR CONNECTOR**

OK

REPLACE ECM