

DTC	P0722	Output Speed Sensor Circuit No Signal
------------	--------------	----------------------------------------------

DESCRIPTION

The speed sensor SP2 detects the rotation speed of the transmission output shaft and sends signals to the ECM. The ECM determines the vehicle speed based on these signals. An AC voltage is generated in the speed sensor SP2 coil as the parking gear mounted on the rear planetary gear assembly rotates, and this voltage is sent to the ECM. The parking gear on the rear planetary gear is used as the timing rotor for this sensor. The gear shift point and lock-up timing are controlled by the ECM based on the signals from the vehicle speed sensor and the throttle position sensor.

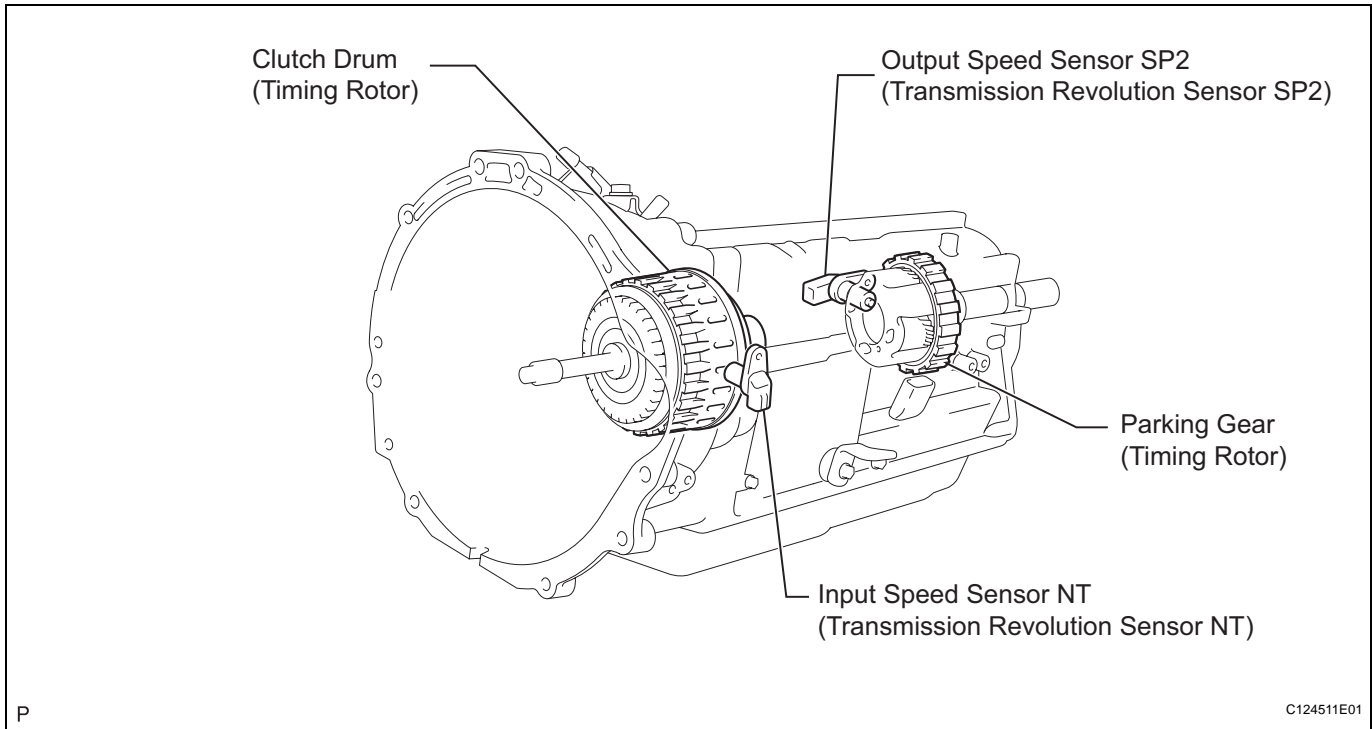

DTC No.	DTC Detection Conditions	Trouble Areas
P0722	All conditions below are detected 500 times or more continuously (1-trip detection logic) (a) No signal from speed sensor (SP2) is input to ECM while 4 pulses of No. 1 vehicle speed sensor signal are sent (b) Vehicle speed is 5.59 mph (9 km/h) or more for at least 4 seconds (c) Park/neutral position switch is OFF	<ul style="list-style-type: none"> • Open or short in speed sensor (SP2) circuit • Speed sensor (SP2) • ECM

Reference (Using an oscilloscope):

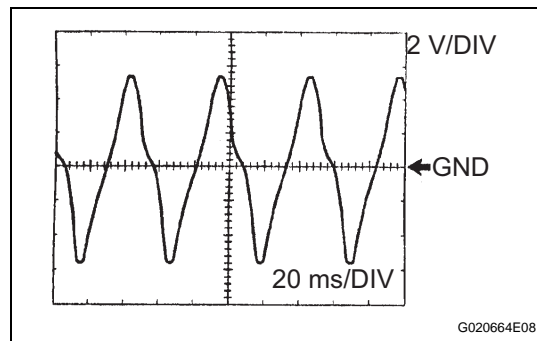

Check the waveform between terminals SP2+ and SP2- of the ECM connector.

Standard:

Refer to the illustration.

Terminal	SP2+ - SP2-
Tool setting	2 V/DIV, 20 ms/DIV
Vehicle condition	Vehicle speed 12 mph (20 km/h)

MONITOR DESCRIPTION

The output speed sensor monitors the output shaft speed. The ECM controls the gearshift point and the lock up timing based on the signals from the output speed sensor and throttle position sensor. If the ECM detects no signal from the output shaft speed sensor even while the vehicle is moving, it will conclude that is a malfunction in the output speed sensor. The ECM will illuminate the MIL and set the DTC.

MONITOR STRATEGY

Related DTCs	P0722: Speed sensor SP2/Verify pulse input
Required sensors/Components	Speed sensor SP2
Frequency of operation	Continuous
Duration	500 output shaft revolutions
MIL operation	Immediate
Sequence of operation	None

TYPICAL ENABLING CONDITIONS

The monitor will run whenever the following DTCs are not present.	P0500: VSS P0748 - P0799: Trans solenoid (range)
Vehicle speed sensor pulse input	4 times
Vehicle speed range (4 seconds or more)	5.59 mph (9 km/h) or more
Park/neutral position switch	OFF
Battery voltage	8 V or more
Ignition switch	ON
Starter	OFF

TYPICAL MALFUNCTION THRESHOLDS

Output speed sensor pulse input	No input
---------------------------------	----------

WIRING DIAGRAM

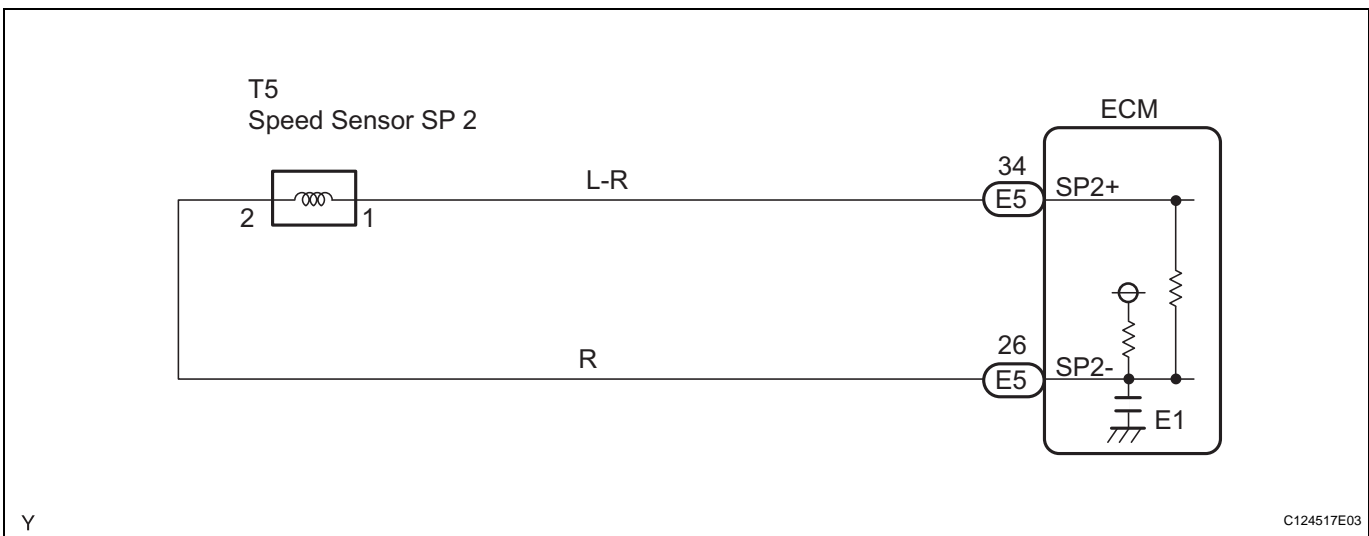

HINT:

According to the DATA LIST displayed on the intelligent tester, you can read the values of components, such as the switches, sensors and actuators, without removing any parts. Reading the DATA LIST as a first step of troubleshooting is one method of shortening labor time.

NOTICE:

In the table below, the values listed under "Normal Condition" are for reference only. Do not depend solely on these reference values when judging whether a part is faulty or not.

1. Connect the intelligent tester together with the CAN VIM (controller area network vehicle interface module) to the DLC3.
2. Turn the ignition switch to the ON position.
3. Push the "ON" button of the tester.
4. Select the items "DIAGNOSIS/ ENHANCED OBD II/ DATA LIST/ A/T".
5. According to the display on the tester, read the "DATA LIST".

Item	Measurement Item/ Range (display)	Normal Condition
SPD (SP2)	Counter Gear Speed display/ min.: 0 mph (0 km/h) max.: 158 mph (255 km/h)	Vehicle stopped: 0 mph (0 km/h) [HINT] Equal to vehicle speed

HINT:

- SPD (SP2) is always 0 while driving:
Open or short in the sensor or circuit.
- The SPD (SP2) value displayed on the tester is much lower than the actual vehicle speed:
Sensor trouble, improper installation, or intermittent connection trouble of the circuit.

1 INSPECT SPEED SENSOR INSTALLATION

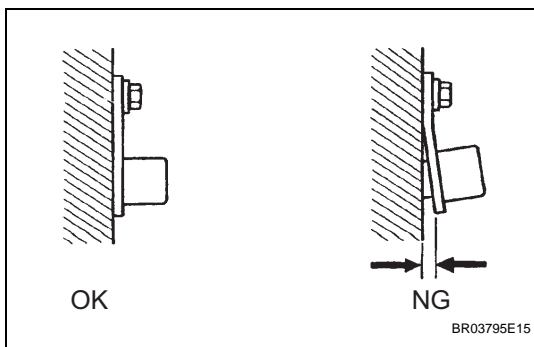

- (a) Check the speed sensor (SP2) installation.

OK:

The installation bolt is tightened properly and there is no clearance between the sensor and transmission case.

NG → **REPLACE SPEED SENSOR (SP2)**

OK

2 INSPECT SPEED SENSOR (SP2)

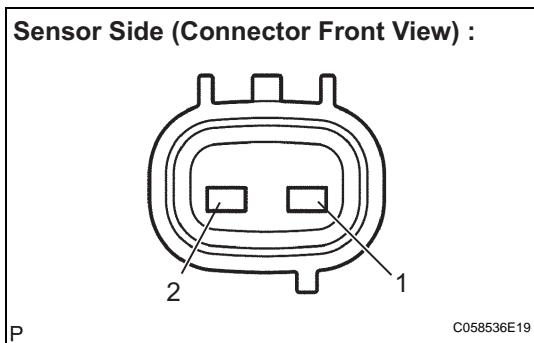

- (a) Disconnect the speed sensor (SP2) connector from the transmission.

- (b) Measure the resistance.

Standard resistance

Tester Connection	Specified Condition
1 - 2	560 to 680 Ω at 20°C (68°F)

NG → **REPLACE SPEED SENSOR (SP2)**

OK

3 CHECK HARNESS AND CONNECTOR (SPEED SENSOR - ECM)

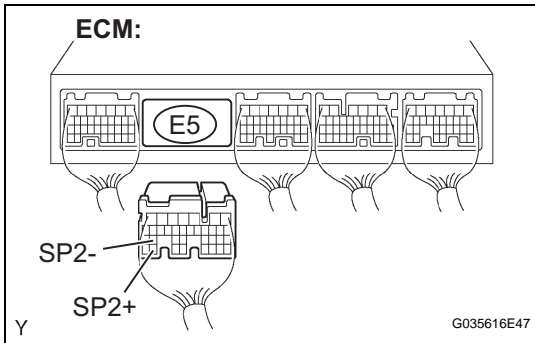

- (a) Connect the speed sensor connector.
- (b) Disconnect the ECM connector.
- (c) Measure the resistance.

Standard resistance

Tester Connection	Specified Condition
E5-34 (SP2+) - E5-26 (SP2-)	560 to 680 Ω at 20°C (68°F)

- (d) Measure the resistance.

Standard resistance (Check for short)

Tester Connection	Specified Condition
E5-34 (SP2+) - Body ground	10 kΩ or higher
E5-26 (SP2-) - Body ground	10 kΩ or higher

NG

REPAIR OR REPLACE HARNESS OR CONNECTOR

OK

REPLACE ECM