

<b>DTC</b>	<b>P2716</b>	<b>Pressure Control Solenoid "D" Electrical (Shift Solenoid Valve SLT)</b>
------------	--------------	--

**DESCRIPTION**

Refer to DTC P2714 (See page [AT-110](#)).

DTC No.	DTC Detection Conditions	Trouble Areas
P2716	Open or short is detected in shift solenoid valve SLT circuit for 1 second or more while driving (1-trip detection logic)	<ul style="list-style-type: none"> <li>• Open or short in shift solenoid valve SLT circuit</li> <li>• Shift solenoid valve SLT</li> <li>• ECM</li> </ul>

**MONITOR DESCRIPTION**

When an open or short is detected in the linear solenoid valve (SLT) circuit, the ECM interprets this as a fault.

The ECM turns on the MIL and stores the DTC.

**MONITOR STRATEGY**

Related DTCs	P2716: Shift solenoid valve SLT/Range check
Required sensors/Components	Shift solenoid valve SLT
Frequency of operation	Continuous
Duration	1 second
MIL operation	Immediate
Sequence of operation	None

**TYPICAL ENABLING CONDITIONS**

The monitor will run whenever the following DTCs are not present.	None
Battery voltage	10 V or more
CPU requested duty ratio to SLT	Less than 75 %
Ignition switch	ON
Starter	OFF

**TYPICAL MALFUNCTION THRESHOLDS**

Output signal duty	100 %
--------------------	-------

**COMPONENT OPERATING RANGE**

Output signal duty ratio	Less than 100 %
--------------------------	-----------------

**WIRING DIAGRAM**

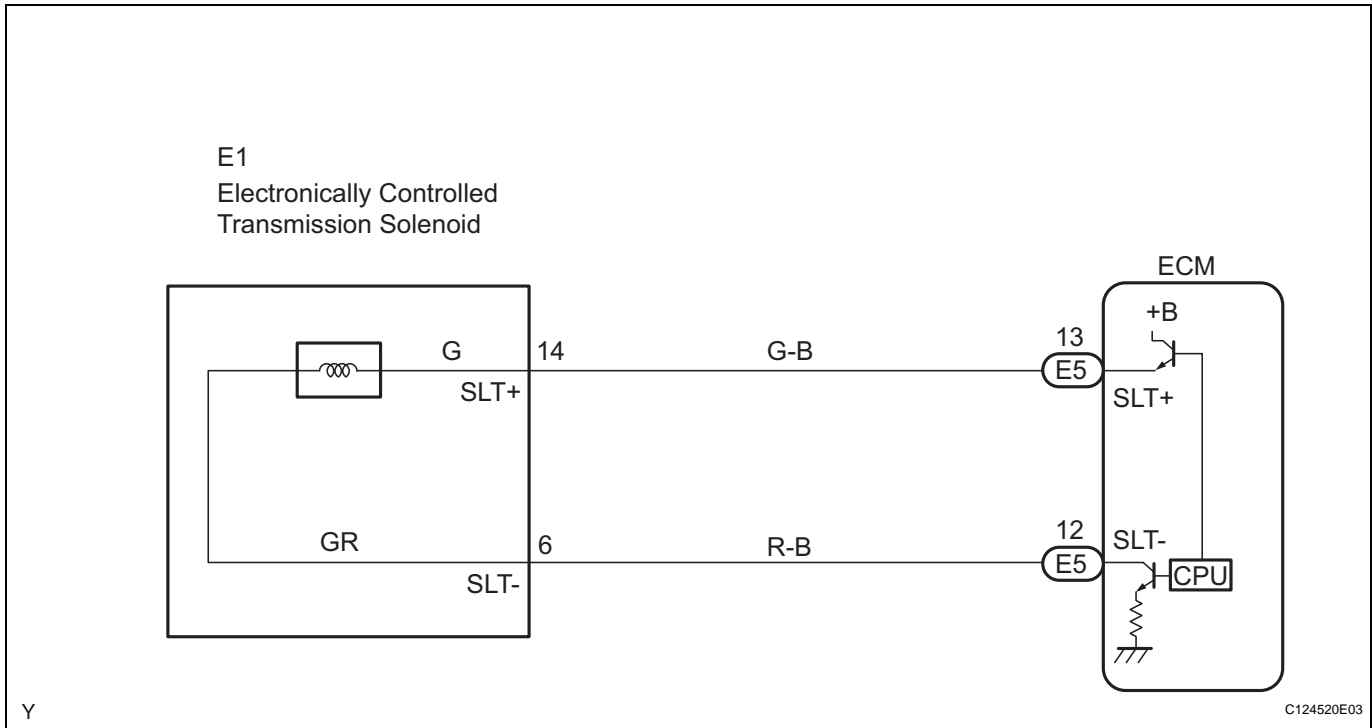

**1 INSPECT TRANSMISSION WIRE (SLT)**

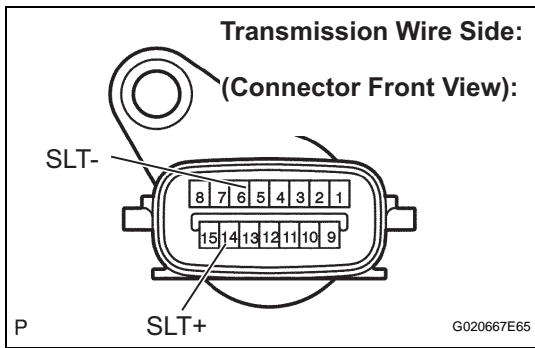

- (a) Disconnect the transmission wire connector from the transmission.
- (b) Measure the resistance.  
**Standard resistance**

Tester Connection	Specified Condition
14 (SLT+) - 6 (SLT-)	5.0 to 5.6 Ω at 20°C (68°F)

- (c) Measure the resistance.  
**Standard resistance (Check for short)**

Tester Connection	Specified Condition
14 (SLT+) - Body ground	10 kΩ or higher
6 (SLT-) - Body ground	10 kΩ or higher

**NG** → **Go to step 3**

**OK**

**2 CHECK HARNESS AND CONNECTOR (TRANSMISSION WIRE - ECM)**

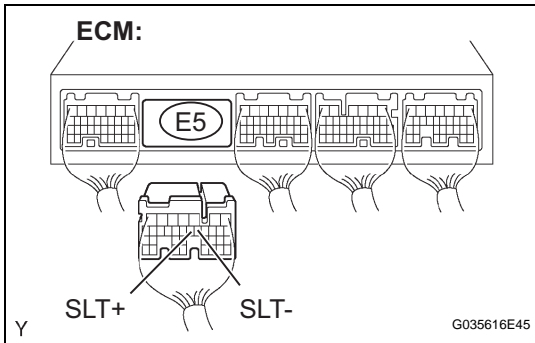

- (a) Connect the transmission wire connector to the transmission.
- (b) Disconnect the ECM connector.
- (c) Measure the resistance.

**Standard resistance**

Tester Connection	Specified Condition
E5-13 (SLT+) - E5-12 (SLT-)	5.0 to 5.6 Ω at 20°C (68°F)

- (d) Measure the resistance.

**Standard resistance (Check for short)**

Tester Connection	Specified Condition
E5-13 (SLT+) - Body ground	10 kΩ or higher
E5-12 (SLT-) - Body ground	10 kΩ or higher

**NG** → **REPAIR OR REPLACE HARNESS OR CONNECTOR**

**OK**

**REPLACE ECM**

**3 INSPECT SHIFT SOLENOID VALVE SLT**

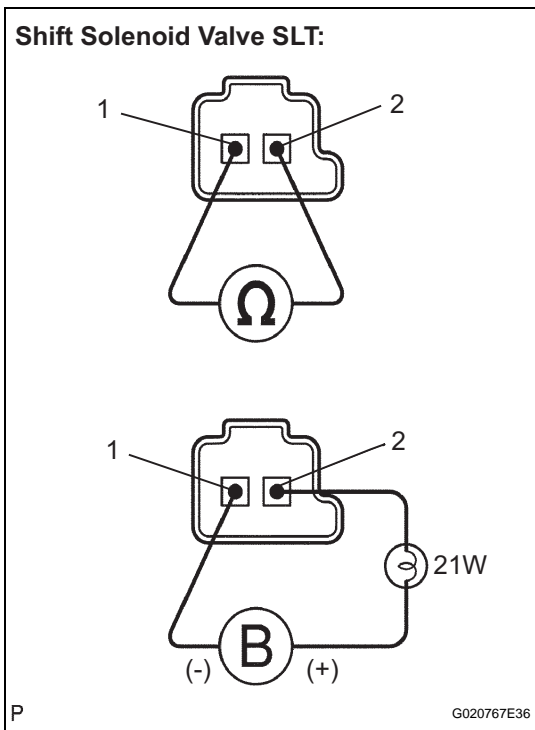

- (a) Remove the shift solenoid valve SLT.
- (b) Measure the resistance.

**Standard resistance**

Tester Connection	Specified Condition
1 - 2	5.0 to 5.6 Ω at 20°C (68°F)

- (c) Connect the positive (+) lead with a 21 W bulb to terminal 2 and the negative (-) lead to terminal 1 of the solenoid valve connector, then check the movement of the valve.

**OK:**

**The solenoid makes an operating noise.**

**NG** → **REPLACE SHIFT SOLENOID VALVE SLT**

OK

REPAIR OR REPLACE TRANSMISSION WIRE