

DTC	P0976	Shift Solenoid "B" Control Circuit Low (Shift Solenoid Valve S2)
------------	--------------	---

DTC	P0977	Shift Solenoid "B" Control Circuit High (Shift Solenoid Valve S2)
------------	--------------	--

DESCRIPTION

Shifting from 1st to 5th is performed in combination with the ON and OFF operation of the shift solenoid valves S1, S2, SR, SL1 and SL2 which are controlled by the ECM. If an open or short circuit occurs in any of the shift solenoid valves, the ECM controls the remaining normal shift solenoid valve to allow the vehicle to be driven smoothly (See page [AT-32](#)).

DTC No.	DTC Detection Conditions	Trouble Areas
P0976	ECM detects short in solenoid valve S2 circuit 2 times when solenoid valve S2 is operated (1-trip detection logic)	<ul style="list-style-type: none"> Short in shift solenoid valve S2 circuit Shift solenoid valve S2 ECM
P0977	ECM detects open in solenoid valve S2 circuit 2 times when solenoid valve S2 is not operated (1-trip detection logic)	<ul style="list-style-type: none"> Open in shift solenoid valve S2 circuit Shift solenoid valve S2 ECM

MONITOR DESCRIPTION

These DTCs indicate an open or short in the shift solenoid valve S2 circuit. When there is an open or short circuit in any shift solenoid valve circuits, the ECM detects the problem and illuminates the MIL and stores the DTC. When the shift solenoid valve S2 is on, if the resistance is 8 Ω or less, the ECM determines that there is a short malfunction in the shift solenoid valve S2 circuit.

When the shift solenoid valve S2 is off, if the resistance is 100 k Ω or more, the ECM determines that the shift solenoid valve S2 circuit is open (See page [AT-32](#)).

MONITOR STRATEGY

Related DTCs	P0976: Shift solenoid valve S2/Range check (Low resistance) P0977: Shift solenoid valve S2/Range check (High resistance)
Required sensors/Components	Shift solenoid valve S2
Frequency of operation	Continuous
Duration	0.064 seconds
MIL operation	Immediate
Sequence of operation	None

TYPICAL ENABLING CONDITIONS

P0976: Range check (Low resistance)

The monitor will run whenever the following DTCs are not present.	None
Shift solenoid valve S2	ON

P0977: Range check (High resistance)

The monitor will run whenever the following DTCs are not present.	None
Shift solenoid valve S2	OFF

TYPICAL MALFUNCTION THRESHOLDS

P0976: Range check (Low resistance)

Shift solenoid valve S2 resistance	8 Ω or less
------------------------------------	--------------------

P0977: Range check (High resistance)

Shift solenoid valve S2 resistance	100 kΩ or more
------------------------------------	----------------

COMPONENT OPERATING RANGE

Shift solenoid valve S2 resistance	11 to 15 Ω at 20°C (68°F)
------------------------------------	---------------------------

AT

WIRING DIAGRAM

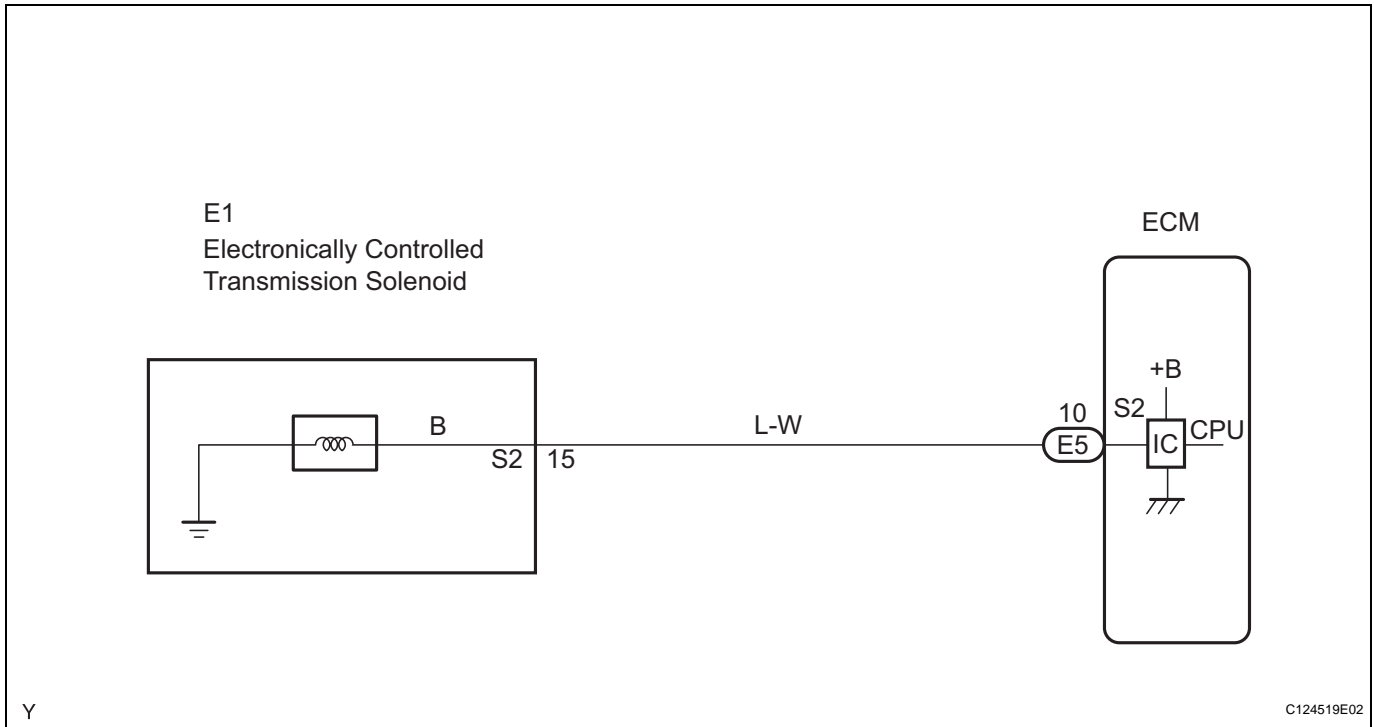

HINT:

The shift solenoid valve S2 is turned on/off normally when the shift lever is in the D position:

Gearshift controlled by ECM	1st	2nd	3rd	4th	5th
Shift solenoid valve S2	OFF	ON	ON	OFF	OFF

1 INSPECT TRANSMISSION WIRE (S2)

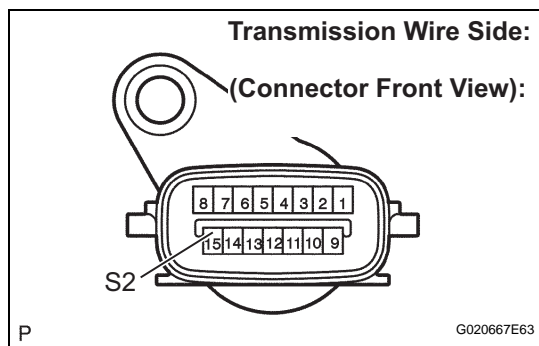

- (a) Disconnect the transmission wire connector from the transmission.
 - (b) Measure the resistance.
- Standard resistance**

Tester Connection	Specified Condition
15 - Body ground	11 to 15 Ω at 20°C (68°F)

NG

Go to step 3

OK

AT

2 CHECK HARNESS AND CONNECTOR (TRANSMISSION WIRE - ECM)

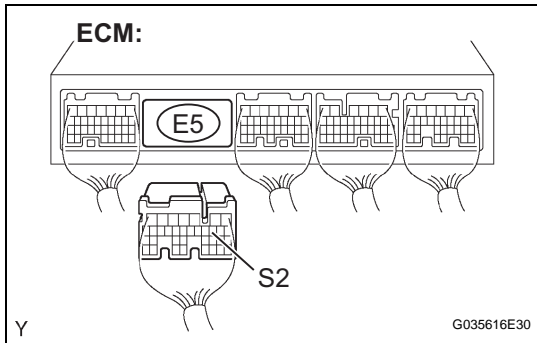

- (a) Connect the transmission wire connector to the transmission.
- (b) Disconnect the ECM connector.
- (c) Measure the resistance.

Standard resistance

Tester Connection	Specified Condition
E5-10 (S2) - Body ground	11 to 15 Ω at 20°C (68°F)

NG REPAIR OR REPLACE HARNESS OR CONNECTOR

OK

REPLACE ECM

3 INSPECT SHIFT SOLENOID VALVE S2

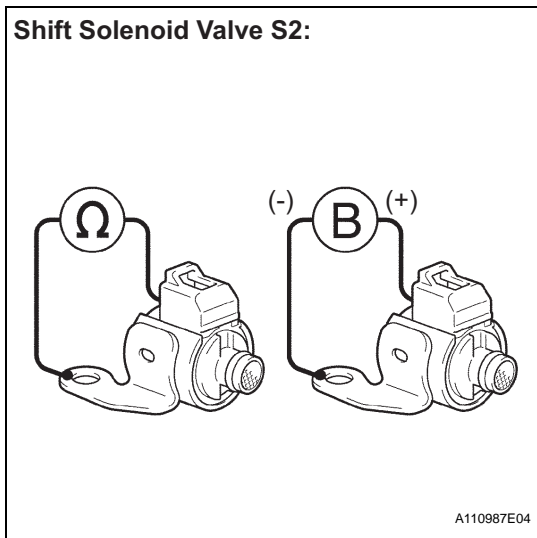

- (a) Remove the shift solenoid valve S2.
- (b) Measure the resistance.

Standard resistance

Tester Connection	Specified Condition
Solenoid Connector (S2) - Solenoid Body (S2)	11 to 15 Ω at 20°C (68°F)

- (c) Connect the positive (+) lead to the terminal of the solenoid connector, and the negative (-) lead to the solenoid body.

OK:

The solenoid makes an operating noise.

NG REPLACE SHIFT SOLENOID VALVE S2

OK

REPAIR OR REPLACE TRANSMISSION WIRE