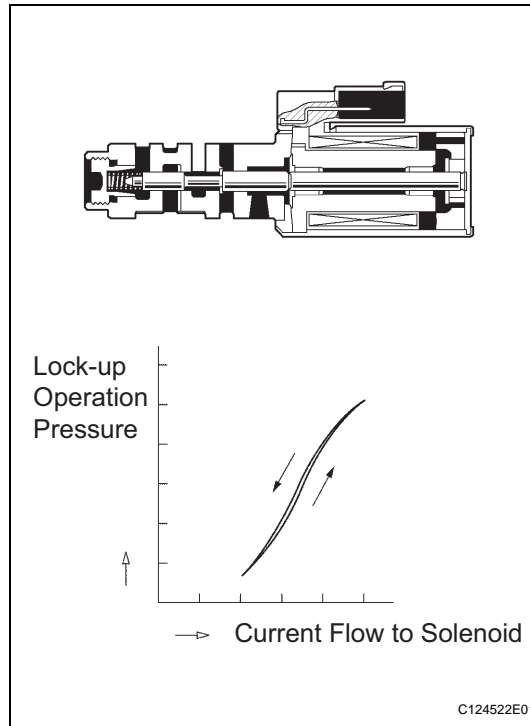

DTC	P2757	Torque Converter Clutch Pressure Control Solenoid Performance (Shift Solenoid Valve SLU)
------------	--------------	---

DESCRIPTION**AT**

The ECM uses the signals from the throttle position sensor, mass air flow meter, turbine (input) speed sensor, output speed sensor and crankshaft position sensor, to monitor the engagement condition of the lock-up clutch.

Then the ECM compares the engagement condition of the lock-up clutch with the lock-up schedule in the ECM memory to detect any mechanical problems with the shift solenoid valve SLU, valve body or torque converter clutch.

DTC No.	DTC Detection Conditions	Trouble Areas
P2757	Lock-up does not occur when driving in the lock-up range (normal driving at 50 mph [80 km/h]), or lock-up remains ON in the lock-up OFF range. (2-trip detection logic)	<ul style="list-style-type: none"> • Shift solenoid valve SLU remains open or closed • Valve body is blocked • Shift solenoid valve SLU • Torque converter clutch • Automatic transmission (clutch, brake or gear, etc.) • Line pressure is too low

MONITOR DESCRIPTION

Torque converter lock-up is controlled by the ECM based on turbine (input) speed sensor NT, output speed sensor SP2, engine rpm, engine load, engine coolant temperature, vehicle speed, transmission fluid temperature, and gear selection. The ECM determines the lock-up status of the torque converter by comparing the engine rpm (NE) with the input turbine rpm (NT). The ECM calculates the actual transmission gear by comparing input turbine rpm (NT) with output shaft rpm (SP2). When the conditions are appropriate, the ECM requests "lock-up" by applying the control voltage to the shift solenoid SLU. When the SLU is turned on, solenoid SLU applies pressure to the lock-up relay valve and locks the torque converter clutch.

If the ECM detects no lock-up after lock-up has been requested or if it detects lock-up when it is not requested, the ECM interprets this as a fault in the shift solenoid valve SLU or lock-up system performance. The ECM turns on the MIL and stores the DTC.

Example:

When any of the following are met, the ECM interprets it as a malfunction.

1. There is a difference in rotation between before and after the torque converter even when the ECM requests lock-up.
(Engine speed is at least 70 rpm greater than the input turbine speed.)
2. There is no difference in rotation between before and after the torque converter even when the ECM requests lock-up off.
(The difference between the engine speed and input turbine speed is less than 35 rpm.)

MONITOR STRATEGY

Related DTCs	P2757: Shift solenoid valve SLU/OFF malfunction Shift solenoid valve SLU/ON malfunction
Required sensors/Components (Main)	Shift solenoid valve SLU
Required sensors/Components (Related)	Valve body, Vehicle speed sensor, Throttle position sensor, Speed sensor (NT), Speed sensor (SP2)
Frequency of operation	Continuous
Duration	OFF malfunction (A): 2 seconds OFF malfunction (B): 0.4 seconds ON malfunction: 1.8 seconds
MIL operation	2 driving cycles
Sequence of operation	None

TYPICAL ENABLING CONDITIONS

The following conditions are common to all OFF malfunctions (A), (B) and ON malfunction.

The monitor will run whenever the following DTCs are not present.	None
Turbine speed sensor (NT) circuit	Functioning normally
Output speed sensor (SP2) circuit	Functioning normally
Shift solenoid "A" (S1) circuit	Functioning normally
Shift solenoid "B" (S2) circuit	Functioning normally
Shift solenoid "E" (SR) circuit	Functioning normally
Torque converter clutch pressure control solenoid circuit	Functioning normally
Knock sensor circuit	Functioning normally
ETCS (Electronic throttle control system)	System not down
Transmission shift position	"D"
ECT	40°C (104°F) or more
Spark advance from max. retard timing by knock sensor control	0° CA or more
Engine	Starting
ECM selected gear	4th or 5th
Vehicle speed	15.5 mph (25 km/h) or more
Shift solenoid "A" (S1) circuit	Functioning normally
Shift solenoid "B" (S2) circuit	Functioning normally
Pressure control solenoid "B" (SL2) circuit	Functioning normally
1-2 shift valve	Functioning normally
Transfer neutral position switch	OFF
Transfer range	"High" *1

*1: Following conditions are met

Vehicle speed sensor "A" circuit	Functioning normally
----------------------------------	----------------------

Output speed sensor circuit	Functioning normally
Transfer output speed	143 rpm or more
Transfer input speed/Transfer output speed	0.9 to 1.1

OFF malfunction (A)

ECM lock-up request	ON (SLU pressure: 513 kPa or more)
Vehicle speed	Less than 62.2 mph (100 km/h)

OFF malfunction (B)

ECM selected gear	2nd
Vehicle speed	1.2 mph (2 km/h) or more
Output speed	2nd → 1st down shift point or more
Throttle valve opening angle	6.5 % or more at engine speed of 2,000 rpm (Conditions vary with engine speed)

ON malfunction

ECM lock-up request	OFF (SLU pressure: less than 4 kPa)
Throttle valve opening angle	7 % or more
Vehicle speed	Less than 37.3 mph (60 km/h)

TYPICAL MALFUNCTION THRESHOLDS

Both of the following conditions are met: OFF malfunction (A) and (B)

OFF malfunction (A)

Engine speed - Turbine speed	70 rpm or more
------------------------------	----------------

OFF malfunction (B)

Turbine speed/Output speed	Not 3.3 to 7.50
----------------------------	--------------------

ON malfunction

2 detections are necessary in 1 driving cycle.

1st detection; temporary flag ON

2nd detection; pending fault code ON

Vehicle speed must be under 6.2 mph (10 km/h) once before the 2nd detection.

Difference between engine speed and turbine speed	Less than 35 rpm
---	------------------

HINT:

Performing the ACTIVE TEST using the intelligent tester allows components, such as, the relay, VSV, and actuator, to be operated without removing any parts. Performing the ACTIVE TEST as a first step of troubleshooting is one method of shortening labor time.

It is possible to display the DATA LIST during the ACTIVE TEST.

1. Warm up the engine.
2. Turn the ignition switch off.
3. Connect the intelligent tester together with the CAN VIM (controller area network vehicle interface module) to the DLC3.
4. Turn the ignition switch to the ON position.
5. Push the "ON" button of the tester.
6. Clear the DTC.
7. Select the items "DIAGNOSIS/ ENHANCED OBD II/ ACTIVE TEST/ LOCK UP".

8. According to the display on the tester, perform the "ACTIVE TEST".

Item	Test Details	Diagnostic Note
LOCK UP	[Test Details] Control the shift solenoid SLU to set the automatic transmission to the lock-up condition. [Vehicle Condition] Vehicle Speed: 36 mph (60 km/h) or more	Possible to check the SLU operation.

AT

HINT:

This test can be conducted when the vehicle speed is 36 mph (60 km/h) or more.

9. Lightly depress the accelerator pedal and check that the engine speed does not change abruptly.

HINT:

- When changing the accelerator pedal opening angle while driving, if the engine speed does not change, lock-up is on.
- Slowly release, but not fully, the accelerator pedal in order to decelerate. (Fully releasing the pedal causes closure of the throttle valve and lock-up may be turned off automatically.)

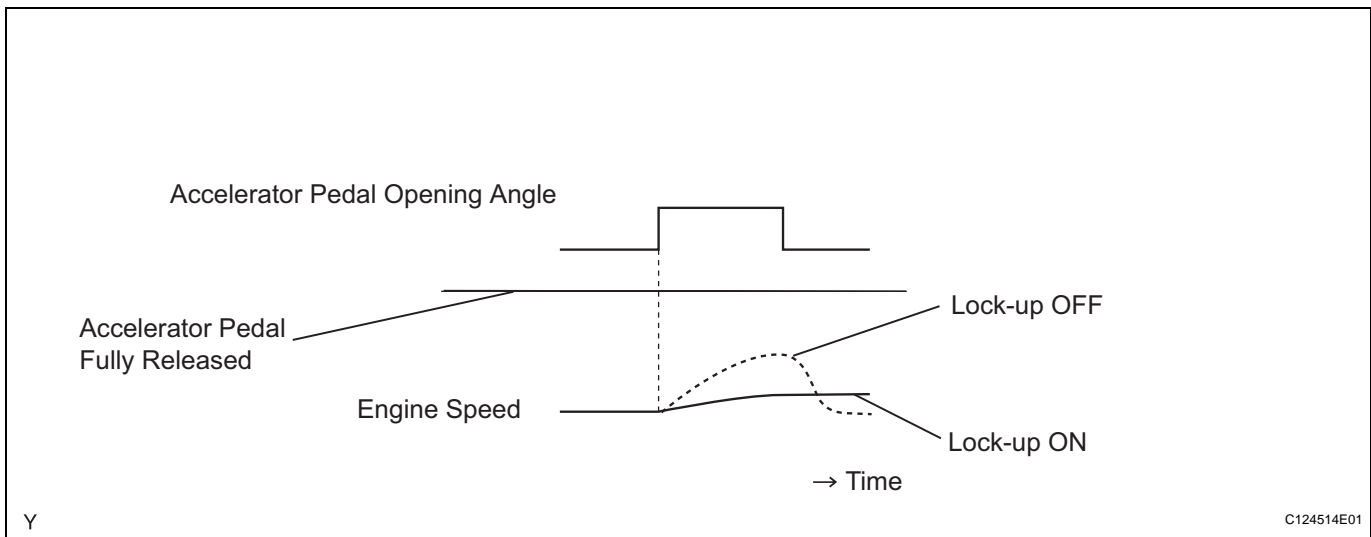

1 CHECK ANY OTHER DTCS OUTPUT (IN ADDITION TO DTC P2757)

- Connect the intelligent tester to the DLC3.
- Turn the ignition switch to the ON position and push the intelligent tester main switch ON.
- Select the items "DIAGNOSIS/ ENHANCED OBD II/ DTC INFO/ CURRENT CODES".
- Read the DTCs using the intelligent tester.

Result:

Display (DTC Output)	Proceed to
Only "P2757" is output	A
P2757" and other DTCs	B

HINT:

If any codes besides "P2757" are output, perform troubleshooting for those DTCs first.

B **GO TO DTC CHART**

A

2 INSPECT SHIFT SOLENOID VALVE SLU

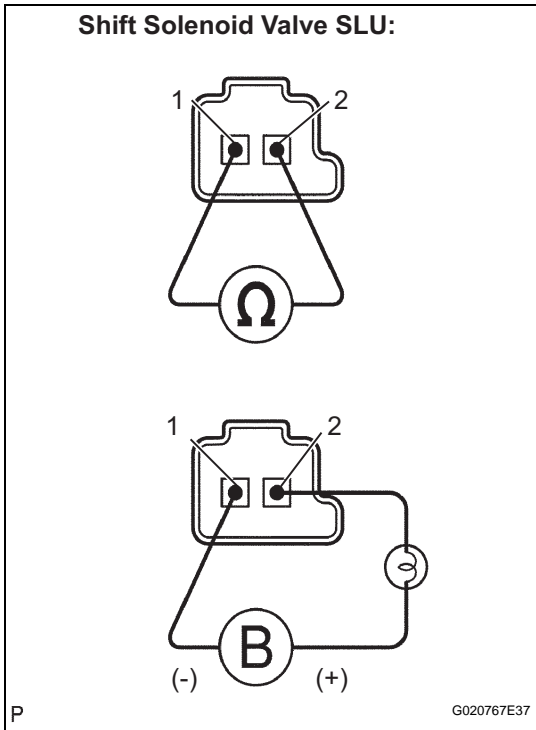

- (a) Remove the shift solenoid valve SLU.
- (b) Measure the resistance.

Standard resistance

Tester Connection	Specified Condition
1 - 2	5.0 to 5.6 Ω at 20°C (68°F)

- (c) Connect the positive (+) lead with a 21 W bulb to terminal 2 and the negative (-) lead to terminal 1 of the solenoid valve connector, then check the movement of the valve.

OK:

The solenoid makes an operating noise.

NG → **REPLACE SHIFT SOLENOID VALVE SLU**

OK

3 INSPECT TRANSMISSION VALVE BODY ASSEMBLY (See chapter 2 in the problem symptoms table)

OK:

There are no foreign objects on any valves and they operate smoothly.

NG → **REPAIR OR REPLACE TRANSMISSION VALVE BODY ASSEMBLY**

OK

4 INSPECT TORQUE CONVERTER CLUTCH ASSEMBLY

- (a) Inspect the torque converter clutch assembly (See page [AT-169](#)).

OK:

The torque converter clutch operates normally.

NG → **REPLACE TORQUE CONVERTER CLUTCH ASSEMBLY**

OK

REPAIR OR REPLACE AUTOMATIC TRANSMISSION ASSEMBLY