

AT

INSTALLATION

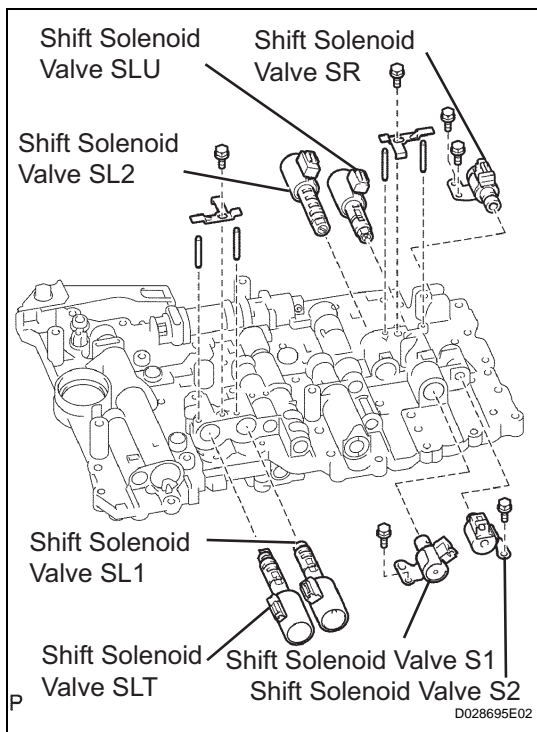

1. INSTALL TRANSMISSION VALVE BODY ASSEMBLY

- (a) Install the shift solenoid valve S2 with the bolt.
Torque: 10 N*m (100 kgf*cm, 7 ft.*lbf)
- (b) Install the shift solenoid valve S1 with the bolt.
Torque: 6.4 N*m (65 kgf*cm, 56 in.*lbf)
- (c) Install the shift solenoid valve SR with the 2 bolts.
Torque: 6.4 N*m (65 kgf*cm, 56 in.*lbf)
- (d) Install the shift solenoid valves SLU and SL2 with the pin, lock plate and bolt.
Torque: 6.4 N*m (65 kgf*cm, 56 in.*lbf)
- (e) Install the shift solenoid valves SLT and SL1 with the pin, lock plate and bolt.
Torque: 6.4 N*m (65 kgf*cm, 56 in.*lbf)
- (f) Insert the pin of the lever into the hole of the manual valve.
- (g) Install 3 new drum seal gaskets onto the transmission case.

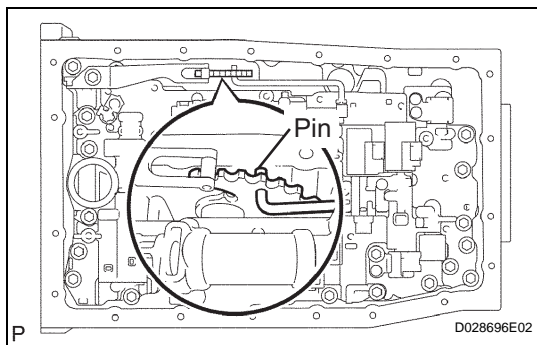

- (h) Install the 19 bolts.
Torque: 11 N*m (110 kgf*cm, 8 ft.*lbf)
Bolt length:
Bolt A: 36 mm (1.42 in.)
Bolt B: 25 mm (0.98 in.)

2. INSTALL TRANSMISSION WIRE (See page AT-144)

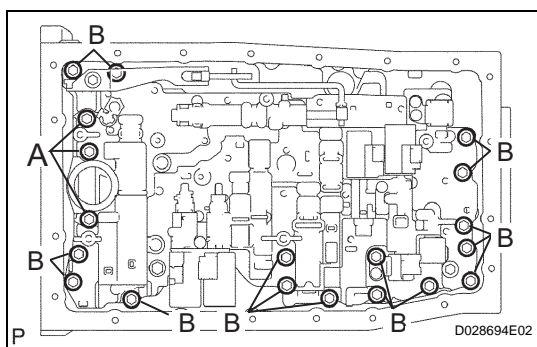

3. INSTALL VALVE BODY OIL STRAINER ASSEMBLY

- (a) Install a new O-ring and the oil strainer with the 4 bolts.
Torque: 10 N*m (100 kgf*cm, 7 ft.*lbf)

4. INSTALL AUTOMATIC TRANSMISSION OIL PAN SUB-ASSEMBLY

HINT:
Remove all packing material and be careful not to drop oil on the contact surfaces of the transmission case and oil pan.

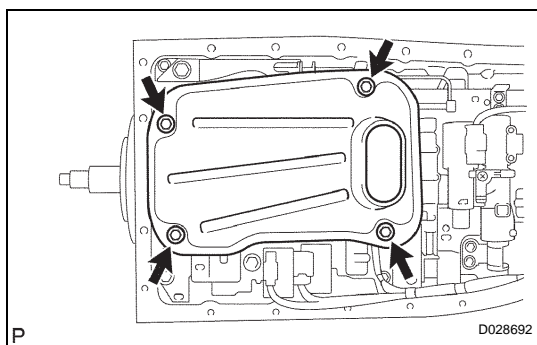

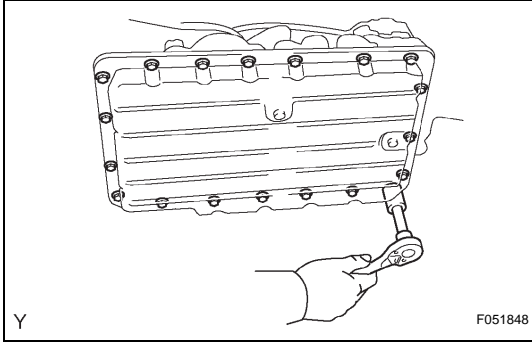

(a) Install a new gasket and the oil pan sub-assembly.

(b) Install the oil pan with the 20 bolts.

Torque: 4.4 N*m (45 kgf*cm, 39 in.*lbf)

5. CONNECT CABLE TO NEGATIVE BATTERY TERMINAL

Torque: 3.9 N*m (40 kgf*cm, 35 in.*lbf)

6. PERFORM INITIALIZATION

(See page [AT-17](#))

7. ADD AUTOMATIC TRANSMISSION FLUID

(See page [AT-139](#))