

CLUTCH UNIT (for RA60)

COMPONENTS

CL

FLYWHEEL SUB-ASSEMBLY

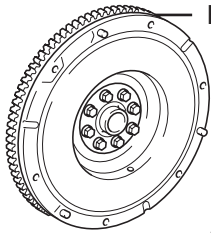

19 (195, 14)

x6

CLUTCH DISC ASSEMBLY

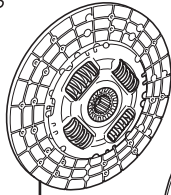

CLUTCH COVER ASSEMBLY

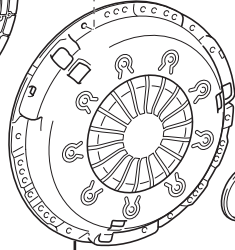

CLUTCH RELEASE BEARING ASSEMBLY



RELEASE BEARING HUB CLIP

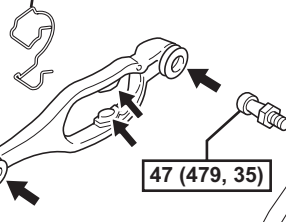

47 (479, 35)

CLUTCH RELEASE FORK SUB-ASSEMBLY

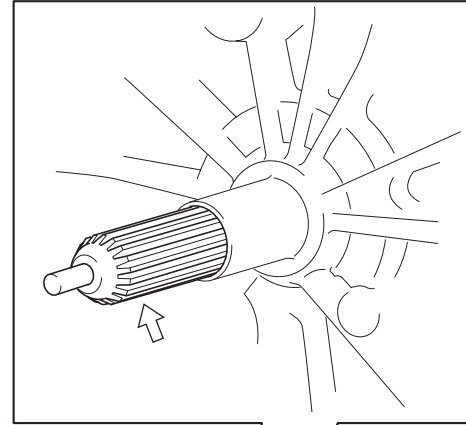

N*m (kgf*cm, ft*lbf) :Specified torque

← Clutch Spline grease

← Release hub grease

Y

REMOVAL

1. REMOVE MANUAL TRANSMISSION UNIT ASSEMBLY

(See page [MT-7](#))

2. REMOVE CLUTCH RELEASE FORK SUB-ASSEMBLY

(a) Remove the clutch release fork together with the clutch release bearing from the transmission assembly.

3. REMOVE CLUTCH RELEASE BEARING ASSEMBLY

(a) Remove the clutch release bearing assembly from the clutch release fork.

4. REMOVE RELEASE FORK SUPPORT

(a) Remove the release fork support from the transaxle assembly.

5. REMOVE RELEASE BEARING HUB CLIP

6. REMOVE CLUTCH COVER ASSEMBLY

(a) Align the matchmark on the clutch cover assembly with the one on the flywheel sub-assembly.

(b) Loosen each set bolt one turn at a time until the spring tension is released.

(c) Remove the 6 bolts and clutch cover assembly.

NOTICE:

Do not drop the clutch disc assembly.

7. REMOVE CLUTCH DISC ASSEMBLY

NOTICE:

Keep the lining part of the clutch disc assembly, pressure plate and surface of the flywheel sub-assembly free from oil and foreign matter.

INSPECTION

1. INSPECT CLUTCH DISC ASSEMBLY

(a) Using vernier calipers, measure the rivet head depth.

Maximum rivet depth:

0.3 mm (0.012 in.)

If necessary, replace the clutch disc assembly.

(b) Install the clutch disc assembly onto the transaxle assembly.

NOTICE:

Take care not to insert the clutch disc assembly in the wrong orientation.

(c) Using a dial indicator, check the clutch disc assembly runout.

Minimum runout:

1.0 mm (0.039 in.)

If necessary, replace the clutch disc assembly.

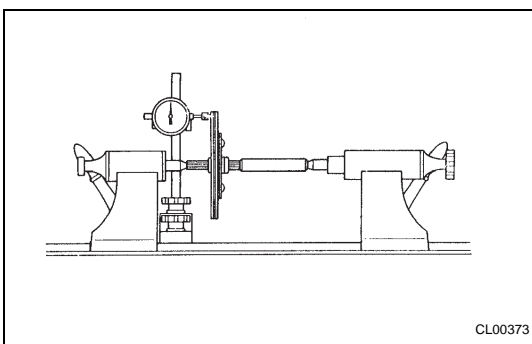
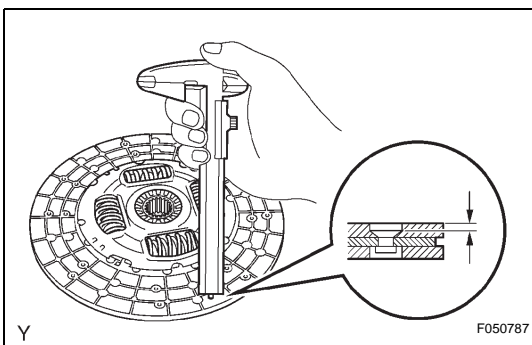
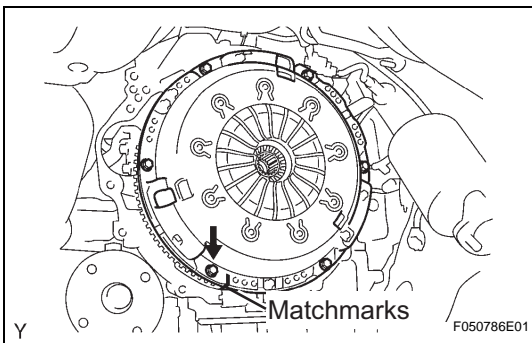
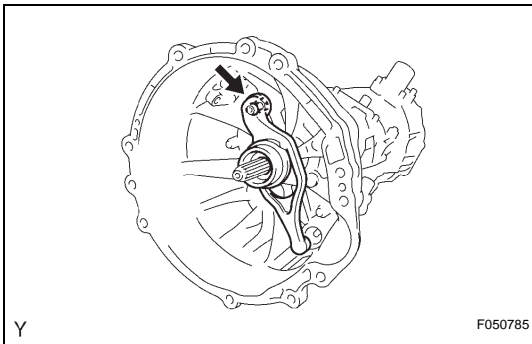

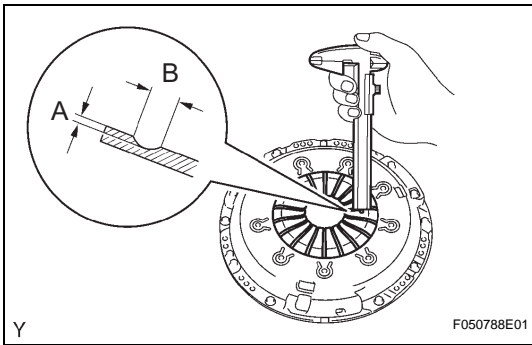

2. INSPECT CLUTCH COVER ASSEMBLY

- (a) Using vernier calipers, inspect the depth and width of wear of the diaphragm spring.

Minimum:

A (Depth): 0.5 mm (0.020 in.)

B (Width): 6.0 mm (0.236 in.)

If necessary, replace the clutch cover assembly.

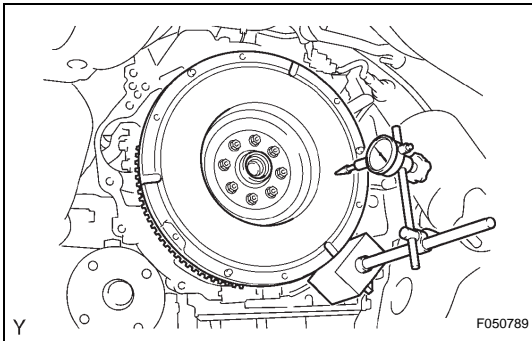

3. INSPECT FLYWHEEL SUB-ASSEMBLY

- (a) Using a dial indicator, inspect the flywheel sub-assembly runout.

Maximum runout:

0.1 mm (0.004 in.)

If necessary, replace the flywheel sub-assembly.

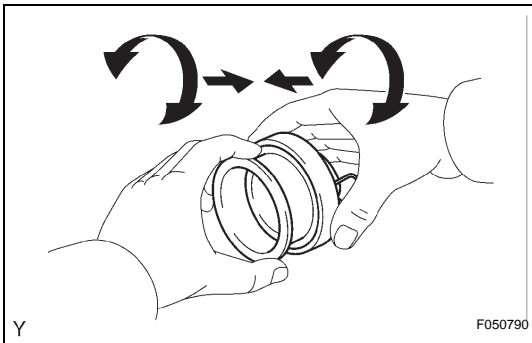

4. INSPECT CLUTCH RELEASE BEARING ASSEMBLY

- (a) Turn the release bearing by hand while applying force in the axial direction.

HINT:

The bearing is permanently lubricated and requires no cleaning or lubrication.

If necessary, replace the release bearing assembly.

INSTALLATION

1. INSTALL CLUTCH DISC ASSEMBLY

- (a) Insert SST into the clutch disc assembly, then insert them into the flywheel sub-assembly.

SST 09301-00220

NOTICE:

Take care not to insert the clutch disc assembly in the wrong orientation.

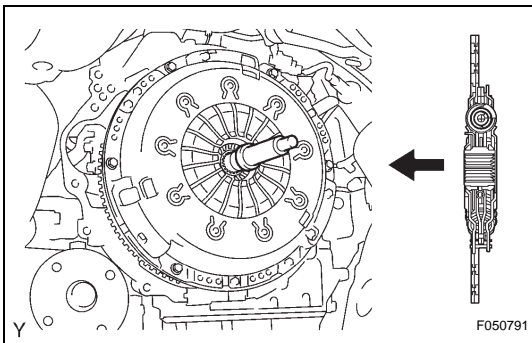

2. INSTALL CLUTCH COVER ASSEMBLY

- (a) Align the matchmarks on the clutch cover assembly and flywheel sub-assembly.
- (b) Following the procedures shown in the illustration, tighten the 6 bolts, in the order starting with the bolt located near the knock pin on the top.

Torque: 19 N*m (195 kgf*cm, 14 ft.*lbf)

HINT:

- Following the order in the illustration, uniformly tighten the bolts.

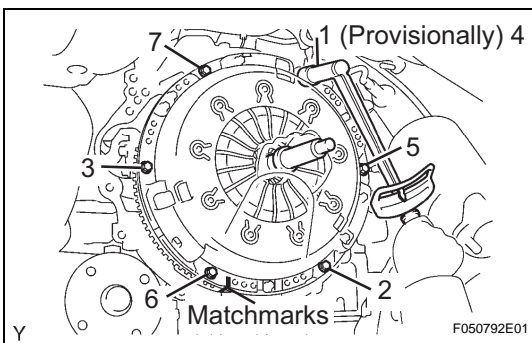

- Move SST up and down, right and left lightly, after checking that the disc is in the center, and tighten the bolts.

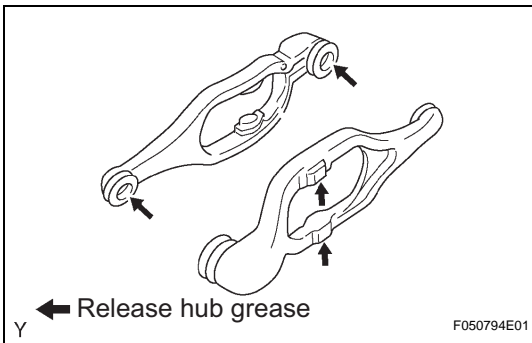
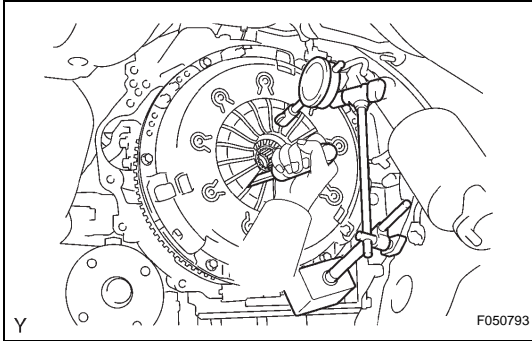

3. INSPECT AND ADJUST CLUTCH COVER ASSEMBLY

- (a) Using a dial indicator with roller instrument, check the diaphragm spring tip alignment.

Maximum non-alignment:

0.5 mm (0.020 in.)

If the alignment is not as specified, adjust the diaphragm spring tip alignment using SST.

SST 09333-00013

4. INSTALL RELEASE FORK SUPPORT

- (a) Install the release fork support onto the transaxle assembly.

Torque: 47 N*m (479 kgf*cm, 35 ft.*lbf)

5. INSTALL RELEASE BEARING HUB CLIP

6. INSTALL CLUTCH RELEASE FORK SUB-ASSEMBLY

- (a) Apply release hub grease to the release fork and release the bearing assembly contact surfaces, release fork and push rod contact surface and release fork pivot point.

Sealant:

Part No. 08887-01806, RELEASE HUB GREASE or equivalent

- (b) Install the release fork onto the release bearing assembly.

7. INSTALL CLUTCH RELEASE BEARING ASSEMBLY

- (a) Apply clutch spline grease to the input shaft spline.

Sealant:

Part No. 08887-01706, CLUTCH SPLINE GREASE or equivalent

- (b) Install the bearing onto the release fork, and then install them onto the transaxle assembly.

NOTICE:

After installation, move the fork forward and backward to check that the release bearing slides smoothly.

8. INSTALL MANUAL TRANSMISSION UNIT ASSEMBLY

(See page [MT-9](#))