

# COUNTER GEAR AND REVERSE IDLER GEAR COMPONENTS

MT

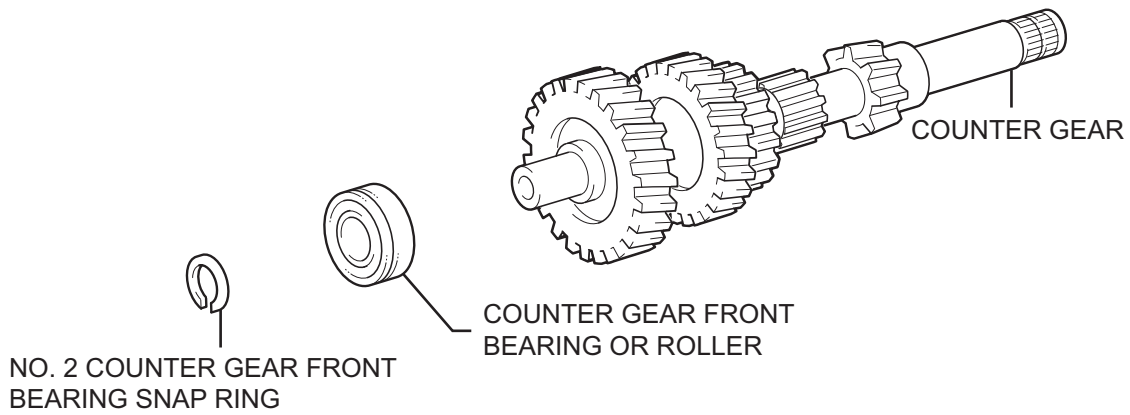

MT

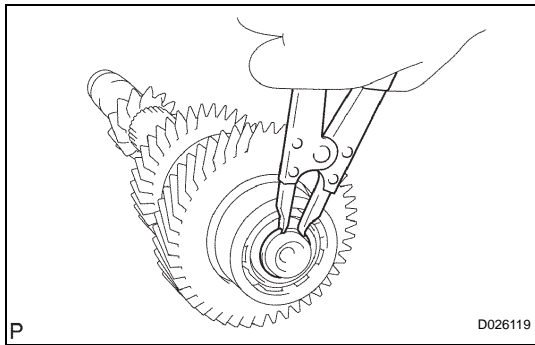

## DISASSEMBLY

### 1. REMOVE NO. 2 COUNTER GEAR FRONT BEARING SNAP RING

- (a) Using a snap ring expander, remove the No. 2 counter gear front bearing snap ring from the counter gear.

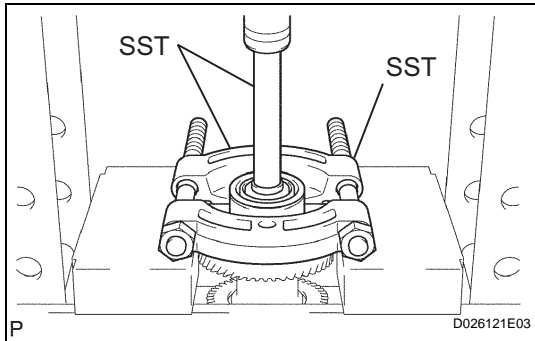

### 2. REMOVE COUNTER GEAR FRONT BEARING OR ROLLER

- (a) Using SST and a press, remove the counter gear front bearing from the counter gear.  
**SST 09950-00020, 09950-60010 (09951-00220), 09950-70010 (09951-07100)**

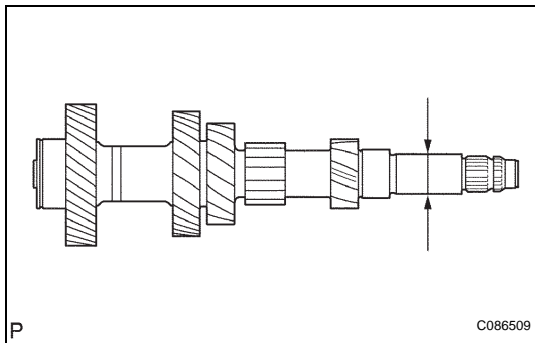

## INSPECTION

### 1. INSPECT COUNTER GEAR

- (a) Using a micrometer, measure the outer diameter of the counter gear as shown in the diagram.

**Standard diameter:**

**29.984 to 30.000 mm (1.1805 to 1.1811 in.)**

**Minimum diameter:**

**29.984 mm (1.1805 in.)**

If the outer diameter is less than the minimum, replace the counter gear with a new one.

## REASSEMBLY

### 1. INSTALL COUNTER GEAR FRONT BEARING OR ROLLER

- (a) Using SST and a press, install the counter gear front bearing onto the counter gear.

**SST 09515-10010**

Install it so that the snap ring groove of the bearing faces to the front side.

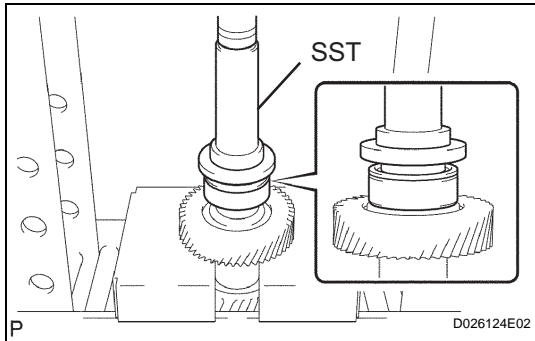

### 2. INSTALL NO. 2 COUNTER GEAR FRONT BEARING SNAP RING

- (a) Select the correct counter gear front bearing No. 2 snap ring so that the clearance between the counter gear and No. 2 counter gear front bearing snap ring No. 2 is within the specified values. Using a brass bar and a hammer, install it onto the counter gear.

**Standard clearance:**

**0.1 mm (0.0039 in.) or less**

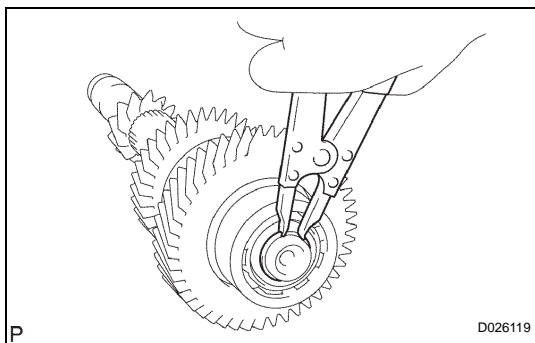

Mark	Thickness mm (in.)
A	2.05 to 2.10 (0.0807 to 0.0827)

Mark	Thickness mm (in.)
B	2.10 to 2.15 (0.0827 to 0.0846)
C	2.15 to 2.20 (0.0846 to 0.0866)
D	2.20 to 2.25 (0.0866 to 0.0886)
E	2.25 to 2.30 (0.0886 to 0.0906)
F	2.30 to 2.35 (0.0906 to 0.0925)

