

MANUAL TRANSMISSION ASSEMBLY

COMPONENTS

BENCH SEAT:

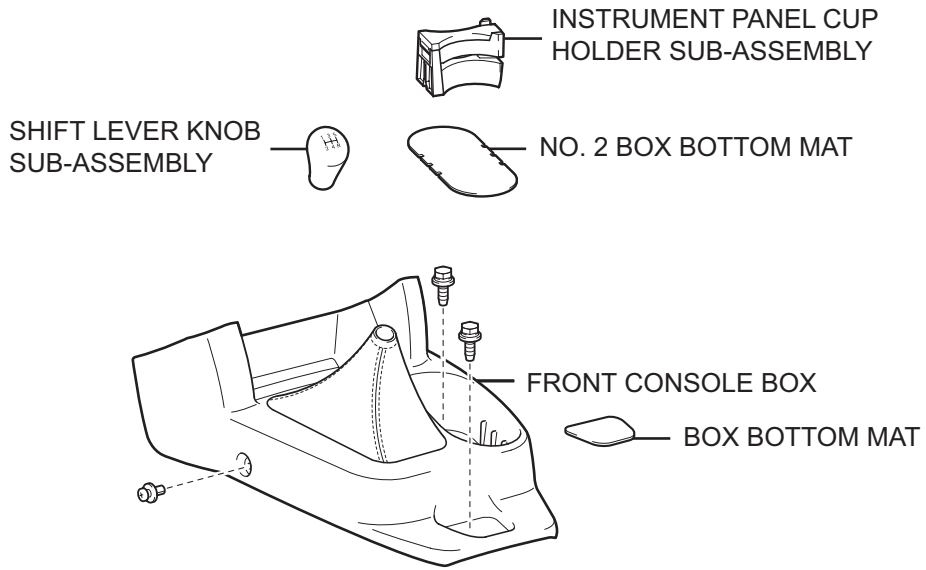

SEPARATE SEAT:

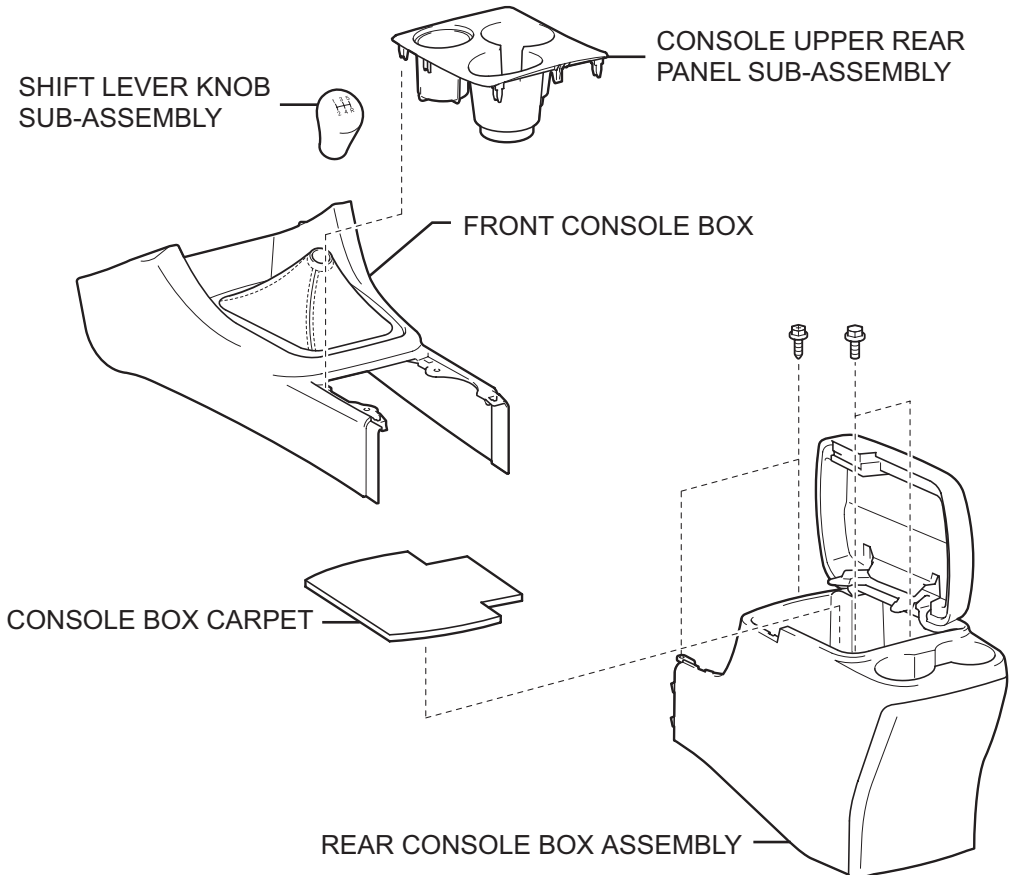

MT

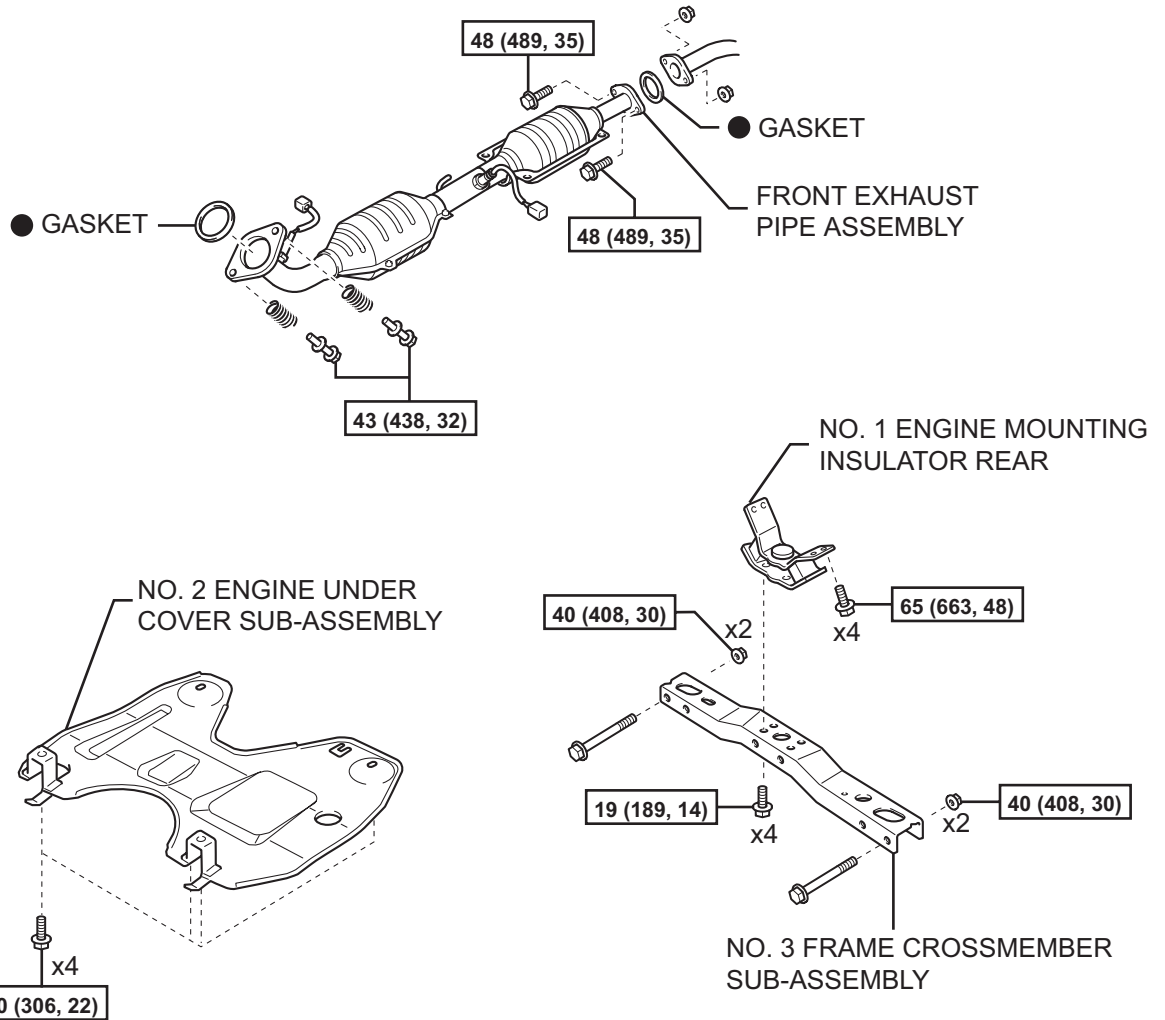

N*m (kgf*cm, ft.*lbf) : Specified torque

● Non-reusable part

MT

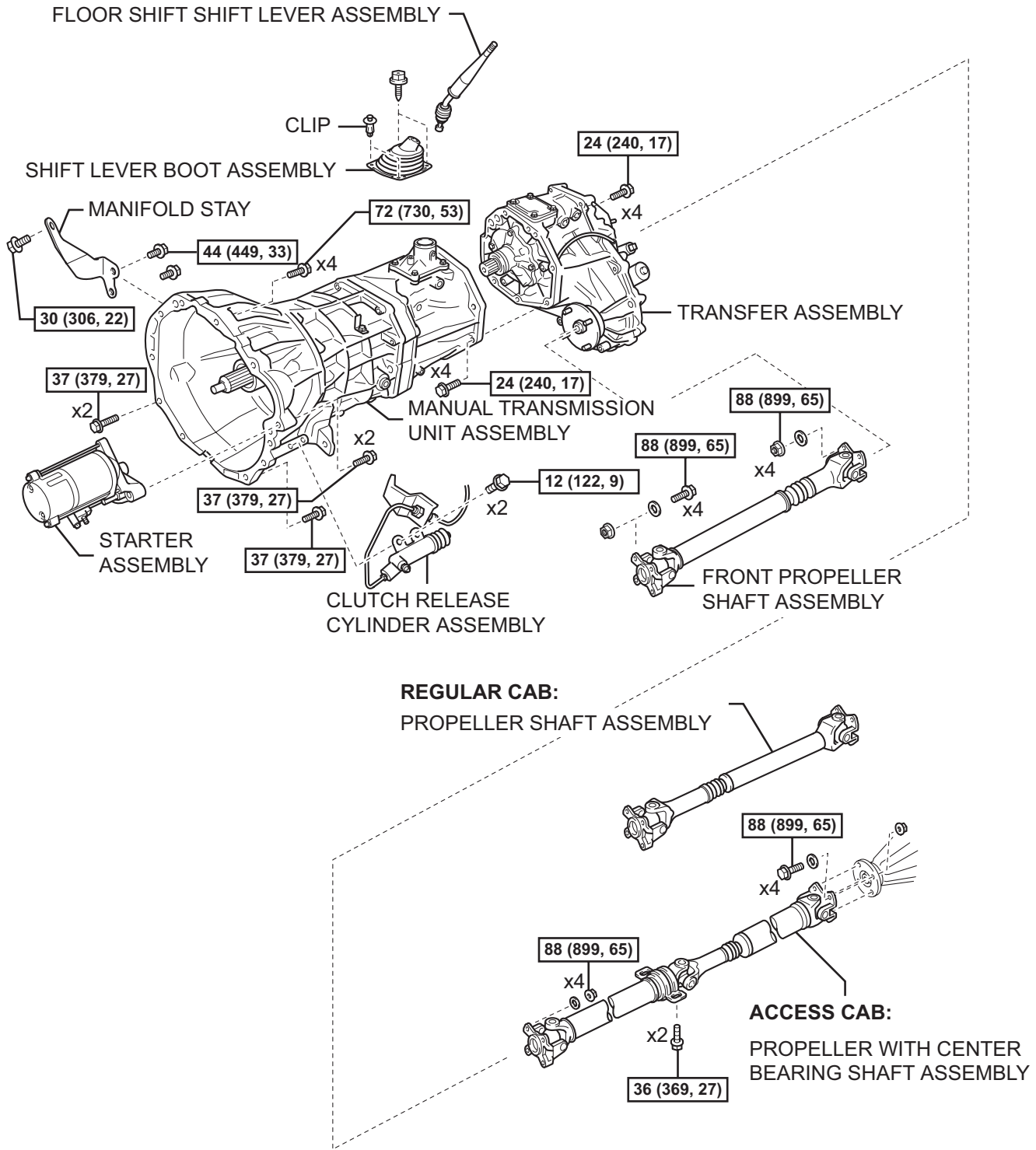

N*m (kgf*cm, ft*lbf) :Specified torque

Y