

MANUAL TRANSMISSION UNIT

COMPONENTS

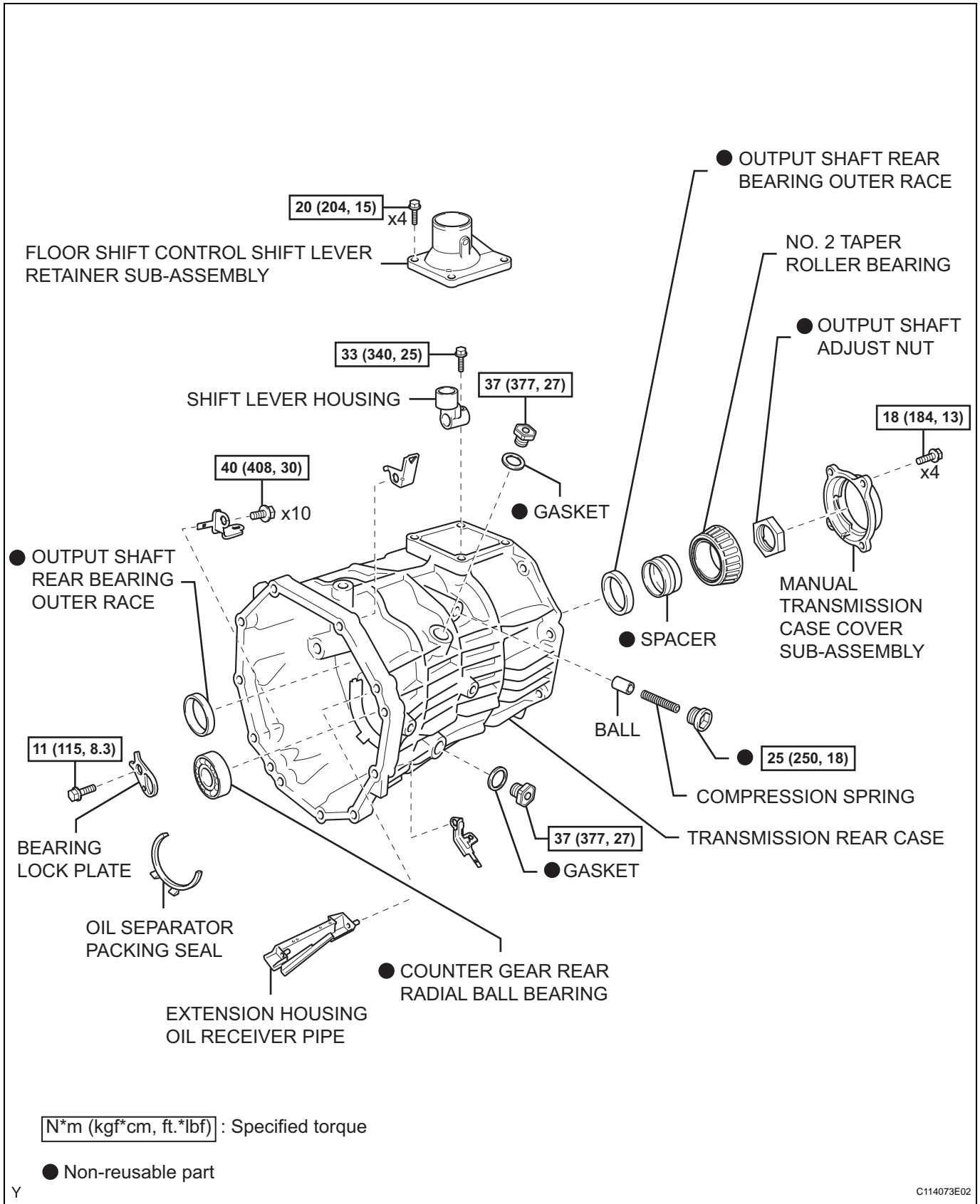

MT

MT

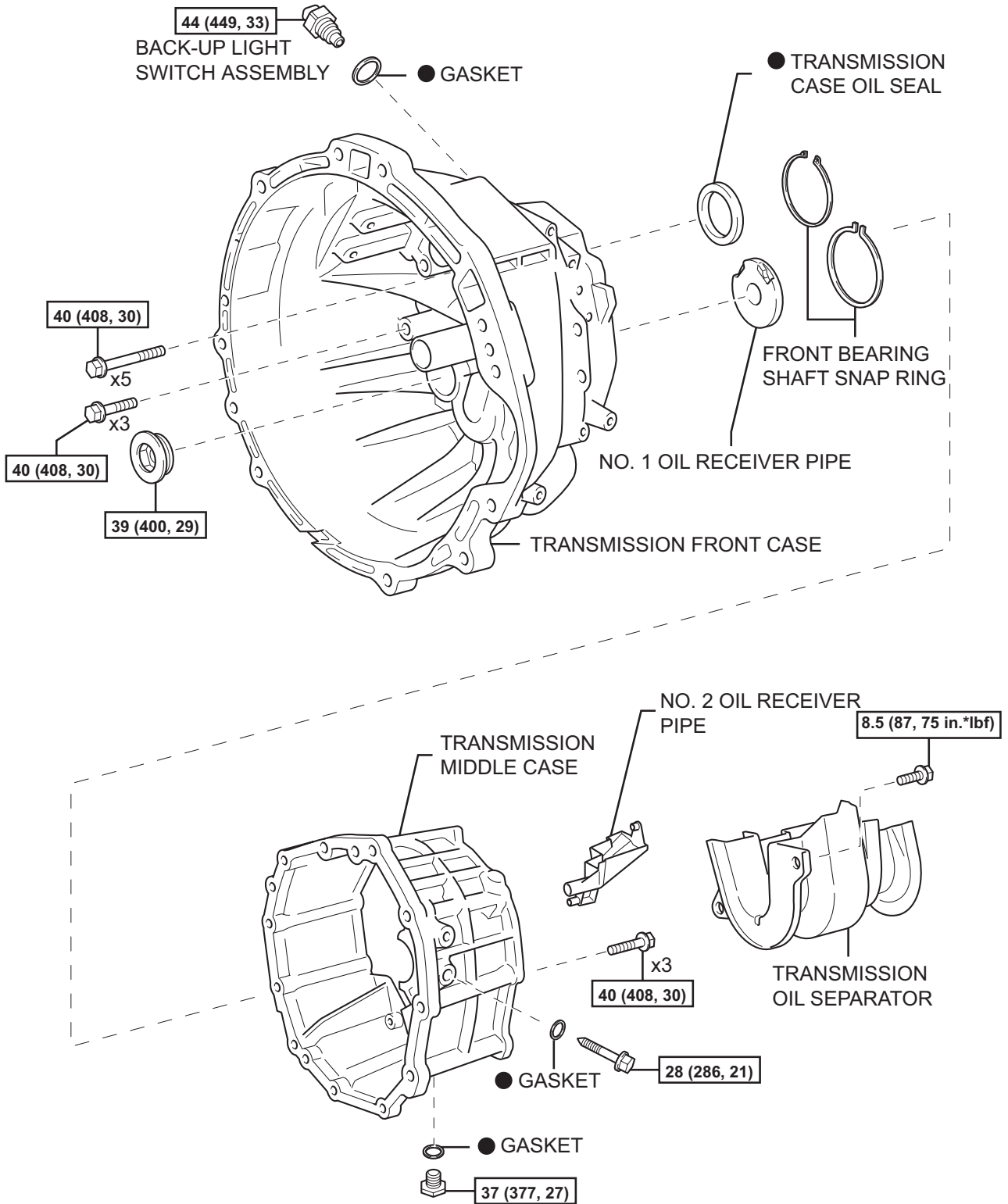

[N*m (kgf*cm, ft.*lbf)] : Specified torque

● Non-reusable part

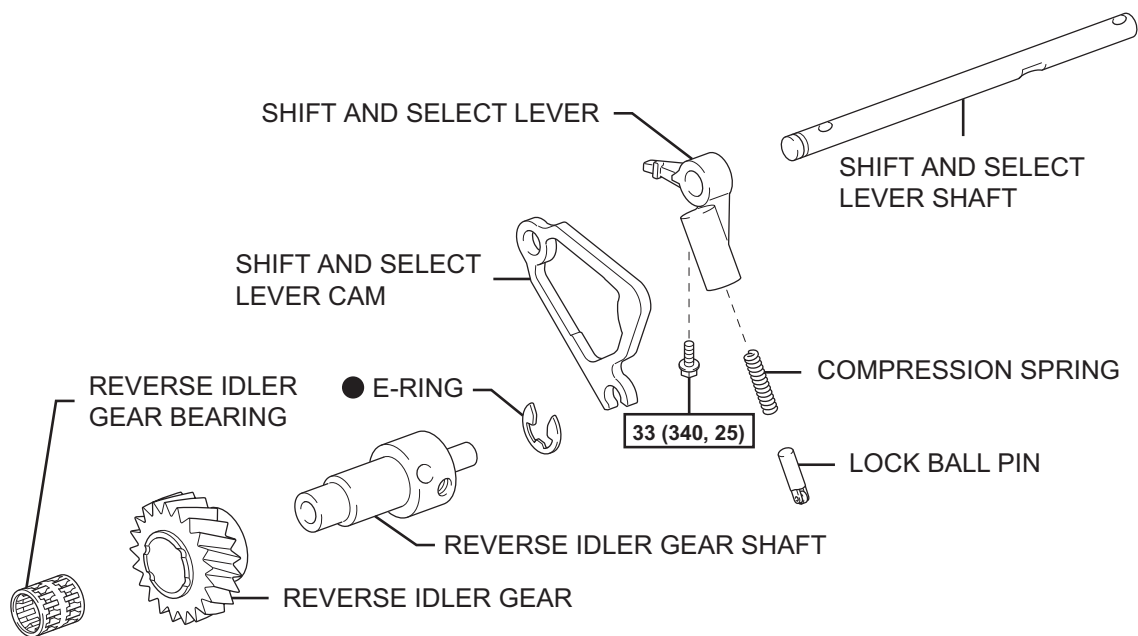
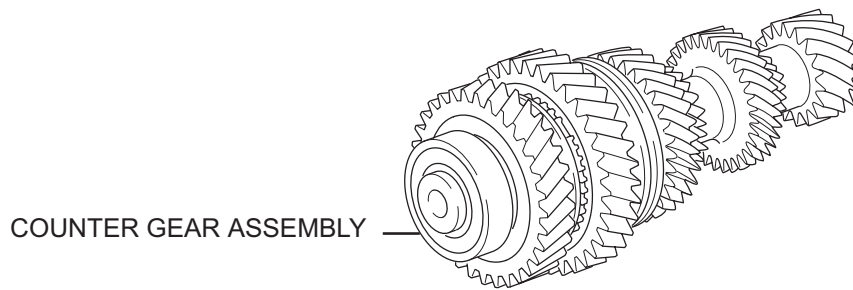
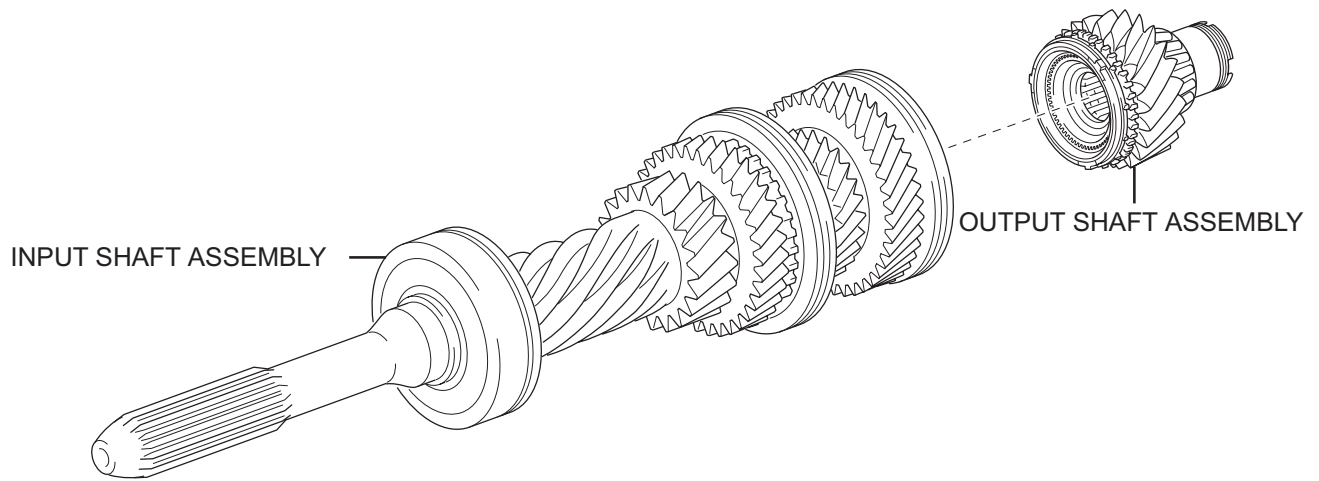

N*m (kgf*cm, ft.*lbf) : Specified torque ● Non-reusable part

MT

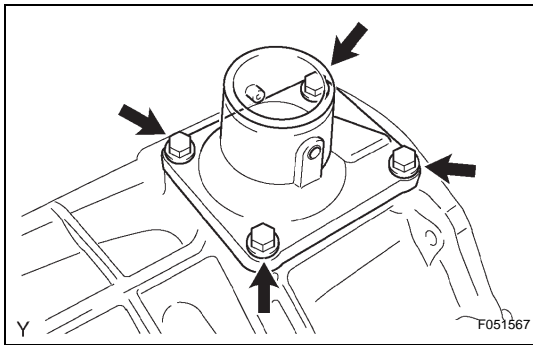
DISASSEMBLY**1. REMOVE FLOOR SHIFT CONTROL SHIFT LEVER RETAINER SUB-ASSEMBLY**

(a) Remove the 4 bolts, then remove the floor shift control shift lever retainer.

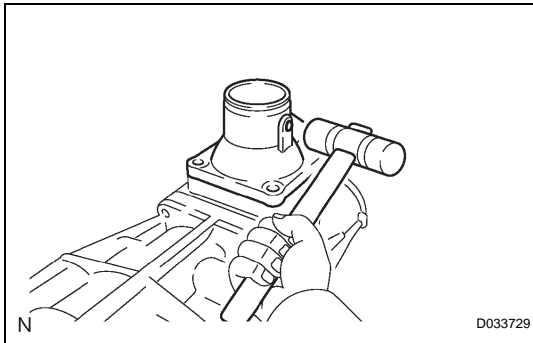

(b) Using a plastic hammer, remove the floor shift control shift lever retainer.

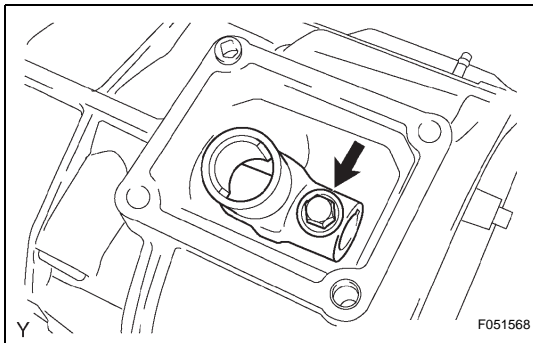
**2. REMOVE SHIFT LEVER HOUSING**

(a) Remove the bolt, then separate the shift lever housing.

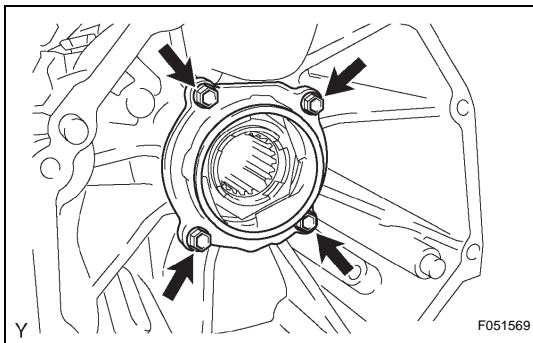
**3. REMOVE MANUAL TRANSMISSION CASE COVER SUB-ASSEMBLY**

(a) Remove the 4 bolts, then remove the transmission case cover.

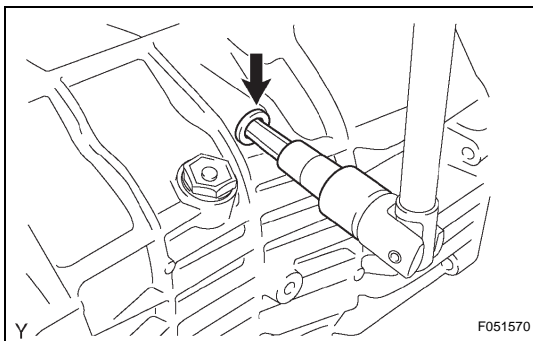
**4. REMOVE SHIFT DETENT BALL PLUG**

(a) Using a socket hexagon wrench (10 mm), remove the shift detent ball plug from the transmission rear case.

(b) Remove the ball and compression spring from the transmission rear case.

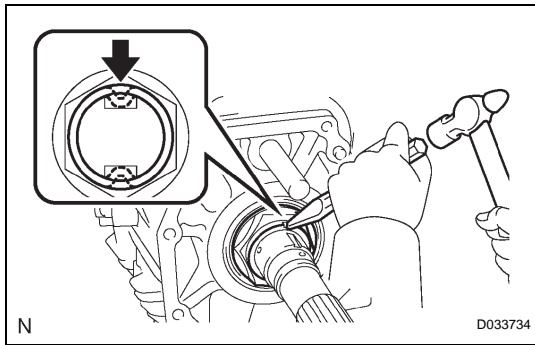

- 5. REMOVE OUTPUT SHAFT ADJUST NUT**
 (a) Using a chisel and hammer, unstake the nut.

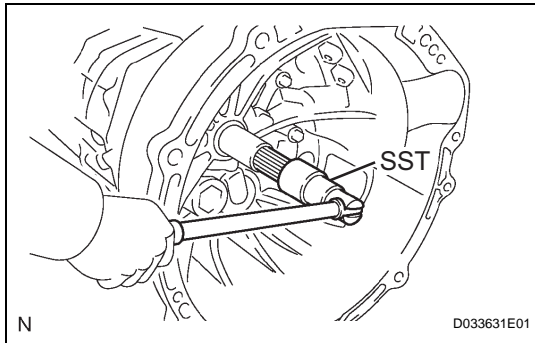

- (b) Place the gearshift into 5th gear, and then fix the input shaft using SST.

SST 09556-16030

- (c) Using a belt and wooden block, fasten the transmission to the workbench.

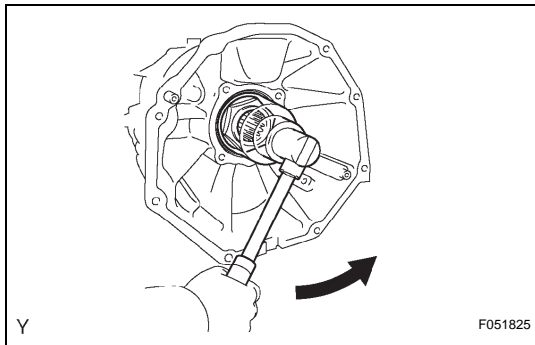

- (d) Using a socket wrench (60 mm), remove the nut from the transmission rear case.

- (e) Remove the belt and wooden block from the transmission.

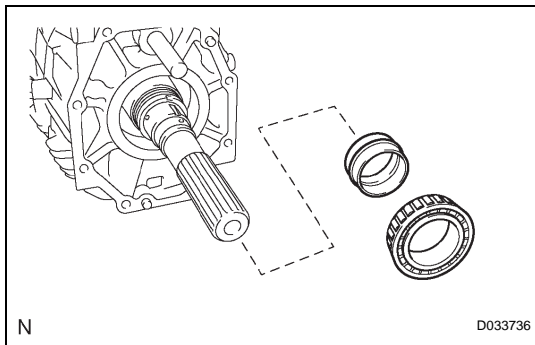

- (f) Remove the taper roller bearing No. 2 and spacer.

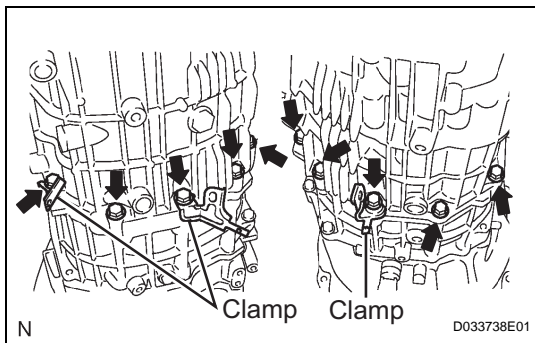

6. REMOVE TRANSMISSION REAR CASE

- (a) Remove the 10 bolts and 3 clamps.

MT

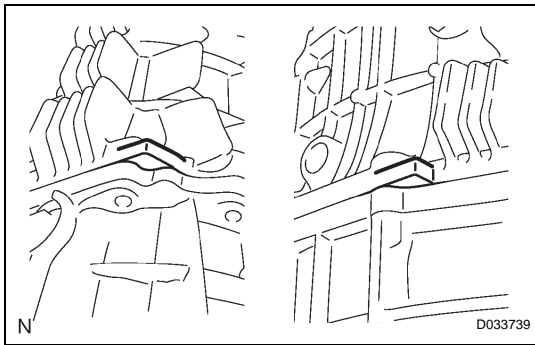

- (b) Using a plastic hammer, carefully tap out the rear case.

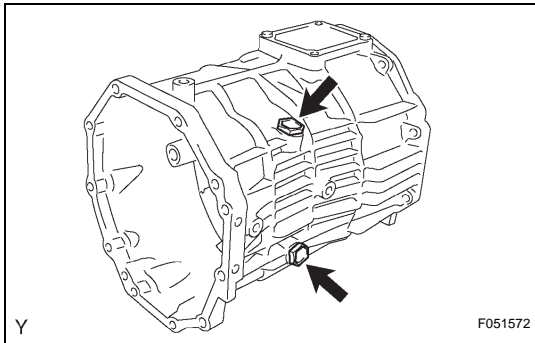

7. REMOVE MANUAL TRANSMISSION FILLER PLUG

- (a) Remove the 2 transmission filler plugs and 2 gaskets from the transmission rear case.

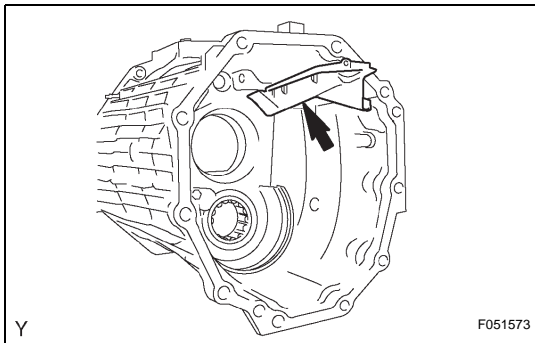

8. REMOVE EXTENSION HOUSING OIL RECEIVER PIPE

- (a) Remove the extension housing oil receiver pipe from the transmission rear case.

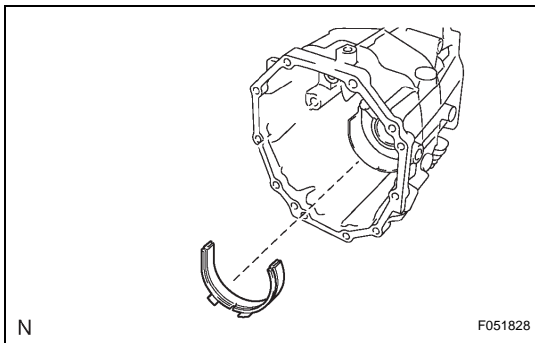

9. REMOVE OIL SEPARATOR PACKING SEAL

- (a) Remove the oil separator packing seal from the transmission rear case.

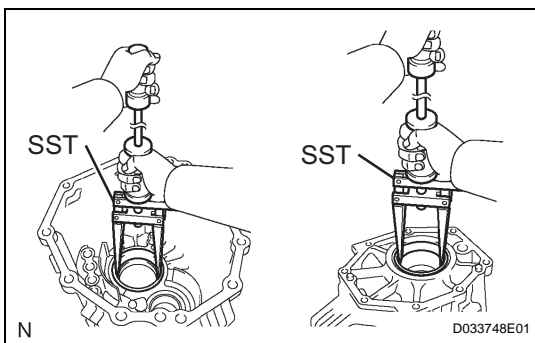

10. REMOVE OUTPUT SHAFT REAR BEARING OUTER RACE

- (a) Using SST, remove the 2 bearing outer races.
SST 09308-00010

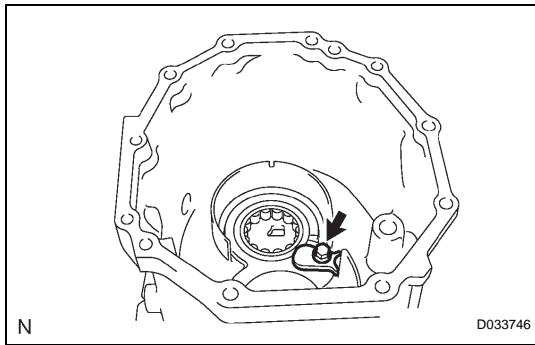

11. REMOVE COUNTER GEAR REAR RADIAL BALL BEARING

(a) Remove the bolt, then remove the bearing lock plate.

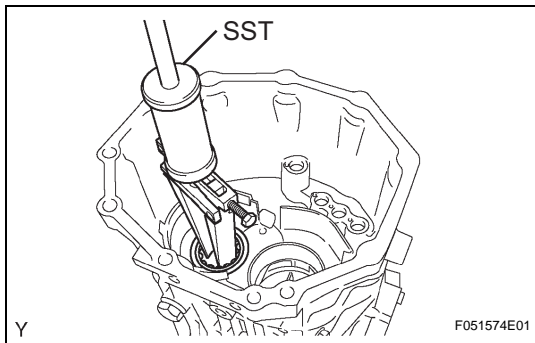

(b) Using SST, remove the counter gear rear radial ball bearing from the transmission rear case.

SST 09308-00010

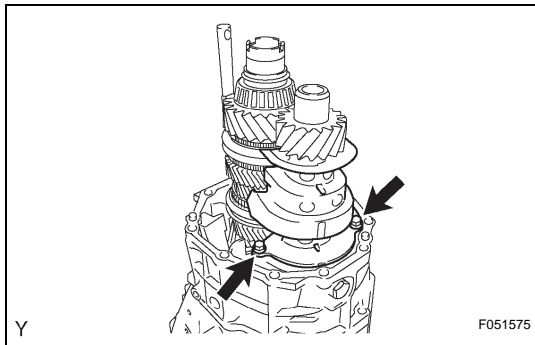

12. REMOVE TRANSMISSION OIL SEPARATOR

(a) Remove the 2 bolts, then remove the oil separator.

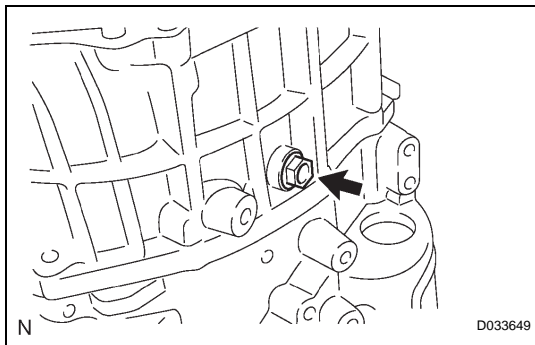

13. REMOVE REVERSE IDLER GEAR SHAFT BOLT

(a) Remove the reverse idler gear shaft bolt from the transmission middle case.

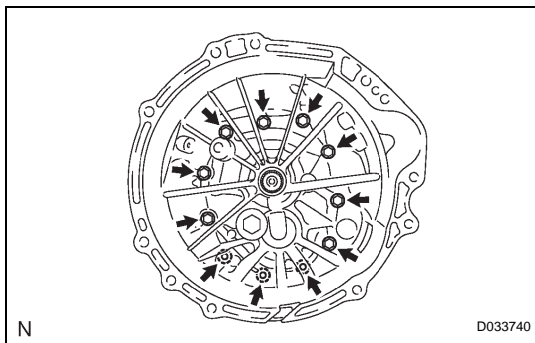

14. REMOVE TRANSMISSION MIDDLE CASE

(a) Remove the 11 bolts, then remove the transmission middle case.

MT

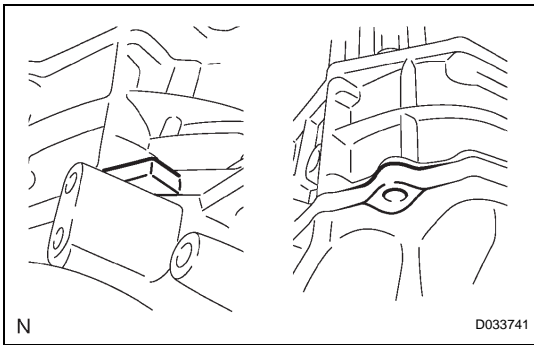

- (b) Using a plastic hammer, carefully tap out the middle case.

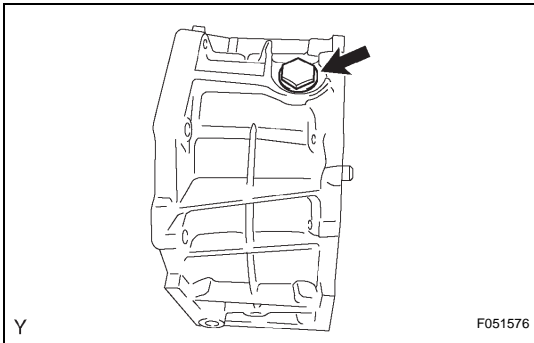

15. REMOVE DRAIN PLUG SUB-ASSEMBLY

- (a) Remove the drain plug and gasket from the transmission middle case.

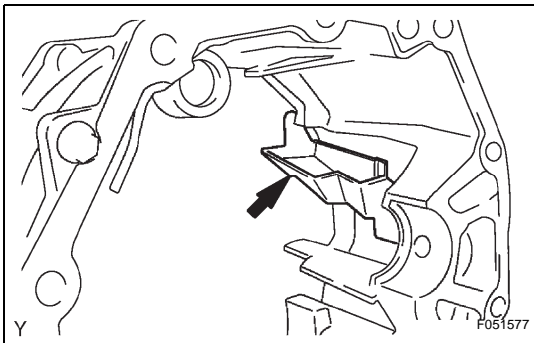

16. REMOVE NO. 2 OIL RECEIVER PIPE

- (a) Remove the oil receiver pipe No. 2 from the transmission middle case.

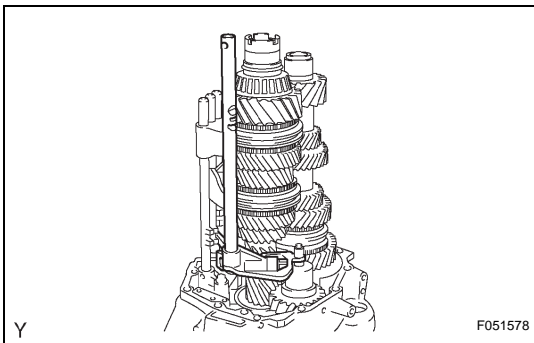

17. REMOVE SHIFT AND SELECT LEVER SHAFT

- (a) Remove the shift and select lever shaft from the reverse gear shaft.

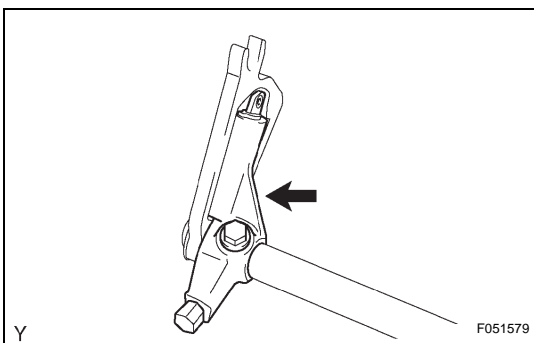

18. REMOVE SHIFT AND SELECT LEVER

- (a) Remove the bolt, then remove the shift and select lever.
(b) Remove the lock ball pin and spring from the shift and select lever.

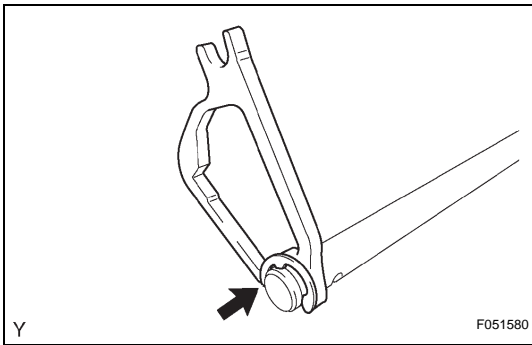
**19. REMOVE SHIFT AND SELECT LEVER CAM**

- (a) Using a screwdriver, remove the E ring and the shift and select lever cam from the shift and select lever shaft.

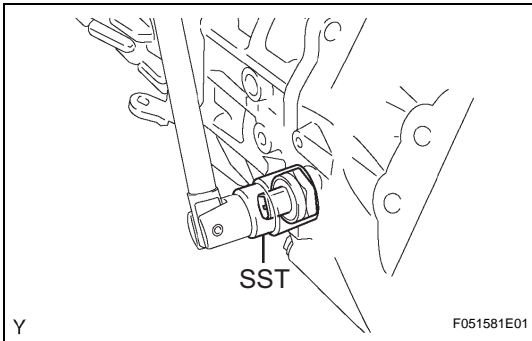
**20. REMOVE BACK-UP LIGHT SWITCH ASSEMBLY**

- (a) Using SST, remove the back-up light switch and gasket.

SST 09817-16011

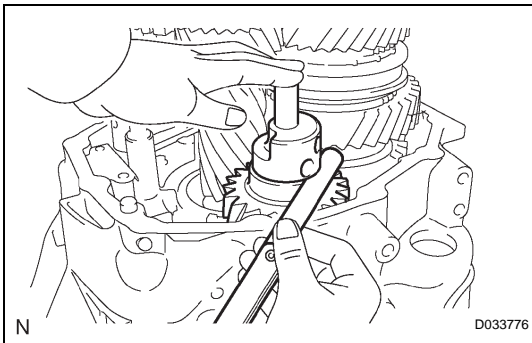
**21. INSPECT REVERSE IDLER GEAR THRUST CLEARANCE**

- (a) Using a feeler gauge, measure the thrust clearance.

Standard clearance:

0.10 to 0.55 mm (0.0039 to 0.0217 in.)

Maximum clearance:

0.55 to (0.0217 in.)

If the clearance exceeds the maximum, replace the reverse idler gear shaft.

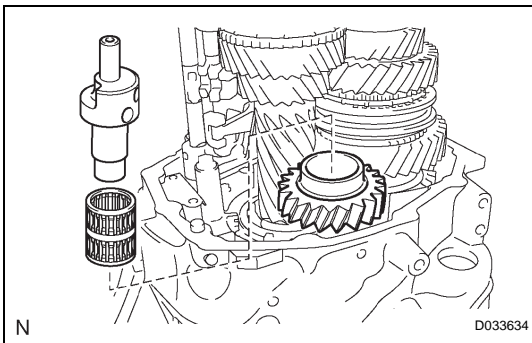
**22. REMOVE REVERSE IDLER GEAR**

- (a) Remove the reverse idler gear shaft, needle roller bearing and reverse idler gear.

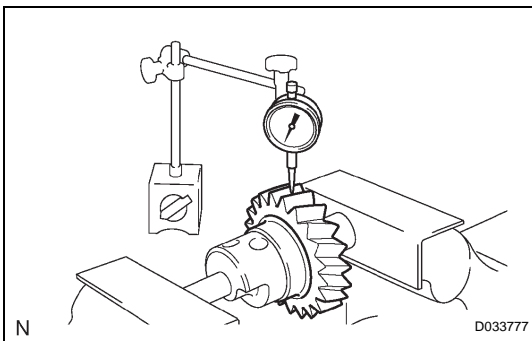
**23. INSPECT REVERSE IDLER GEAR RADIAL CLEARANCE**

- (a) Using a dial indicator, measure the radial clearance.

Standard clearance:

0.015 to 0.050 mm (0.0006 to 0.0020 in.)

Maximum clearance:

0.050 mm (0.0020 in.)

If the clearance exceeds the maximum, replace the needle roller bearing.

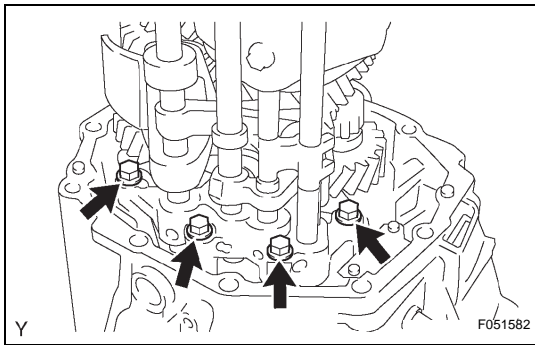

24. REMOVE TRANSMISSION FRONT CASE

(a) Remove the 4 bolts from the interlock bracket.

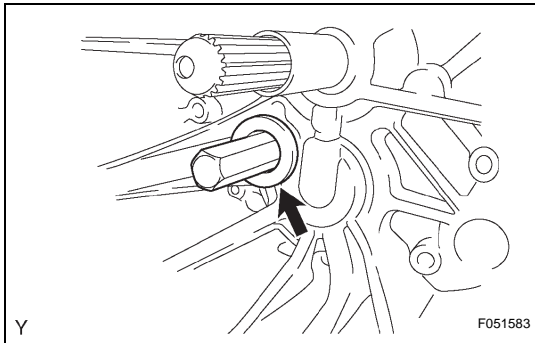

(b) Using a hexagon wrench (24 mm), remove the plug.

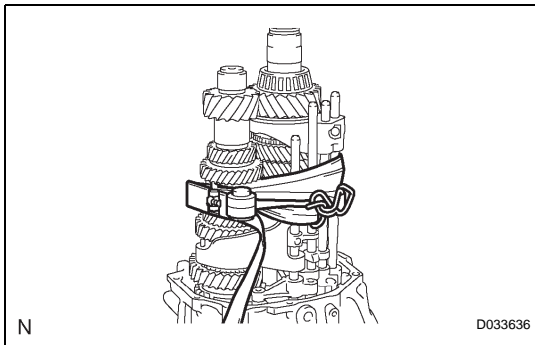

(c) Tie the input shaft, counter gear and control assembly with a rope or string.

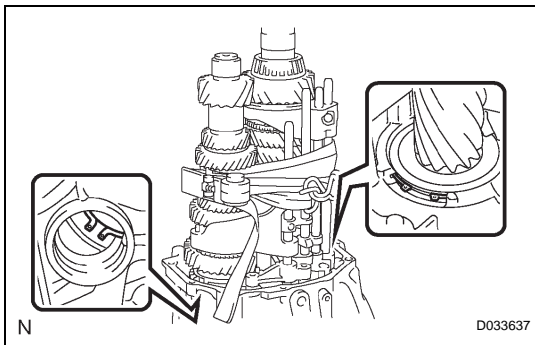

(d) Expand the 2 snap rings, and lift up the output shaft, input shaft, counter gear and control assembly.

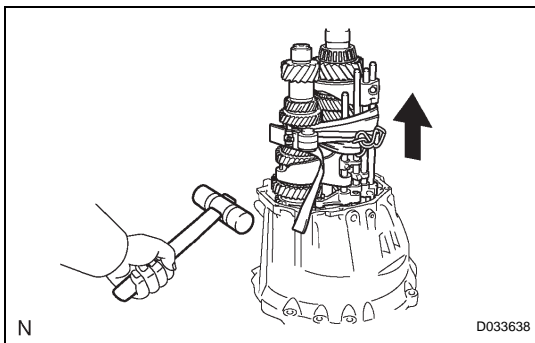

(e) Remove the output shaft, input shaft, counter gear shaft and control assembly while gently tapping the clutch housing with a plastic hammer.

NOTICE:

Take care not to subject the output shaft, input shaft, counter gear shaft and control assembly to any impact. This could cause the ball and spring to come out.

(f) Separate the output shaft, input shaft, counter gear shaft and control assembly.

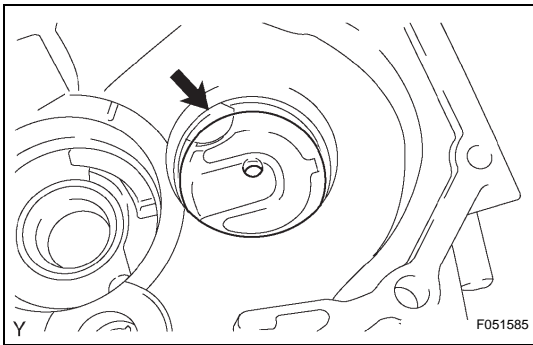

25. REMOVE NO. 1 OIL RECEIVER PIPE

- (a) Remove the oil receiver pipe No. 1 from the transmission front case.

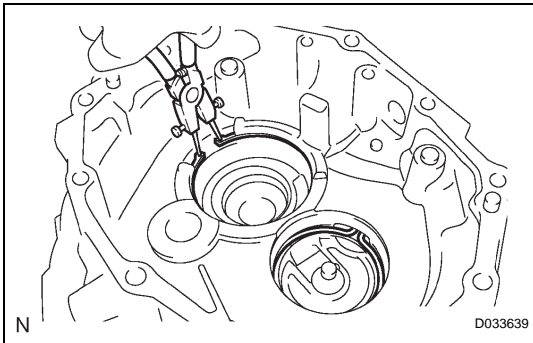

26. REMOVE FRONT BEARING SHAFT SNAP RING

- (a) Using a snap ring plier, remove the 2 snap rings.

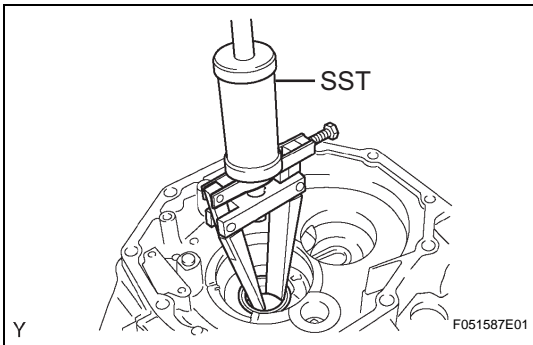

27. REMOVE TRANSMISSION CASE OIL SEAL

- (a) Using SST, remove the transmission case oil seal from the transmission front case.
SST 09308-00010

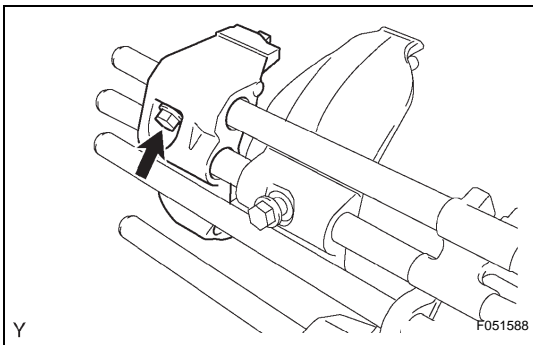

28. REMOVE NO. 3 GEAR SHIFT FORK

- (a) Remove the bolt, then remove the gear shift fork No. 3.

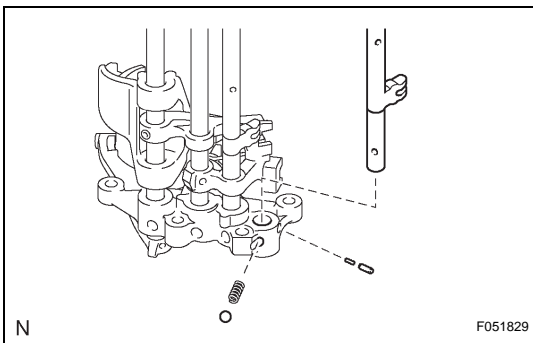

29. REMOVE NO. 3 GEAR SHIFT FORK SHAFT

- (a) Remove the shift fork shaft No. 3, boll, spring, interlock pin No. 2 and interlock pin No. 3.

MT

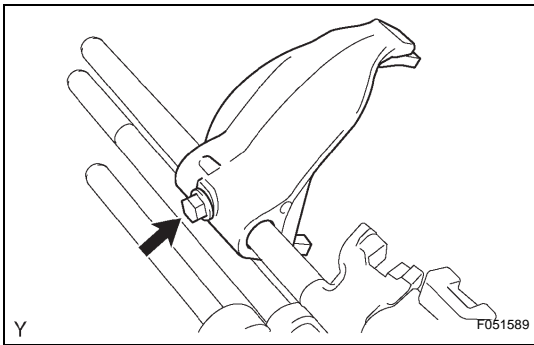
**30. REMOVE NO. 2 GEAR SHIFT FORK**

- (a) Remove the bolt, then remove the gear shift fork No. 2.

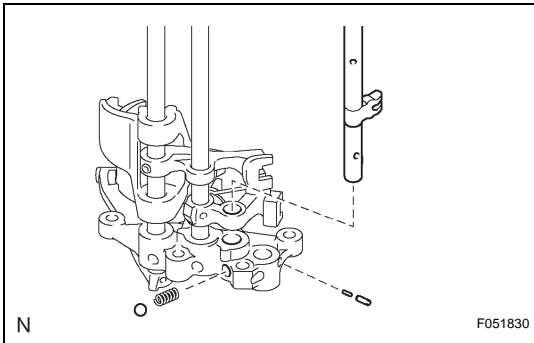
**31. REMOVE NO. 2 GEAR SHIFT FORK SHAFT**

- (a) Remove the shift fork shaft No. 2, ball, spring, interlock pin No. 2 and interlock pin No. 3.

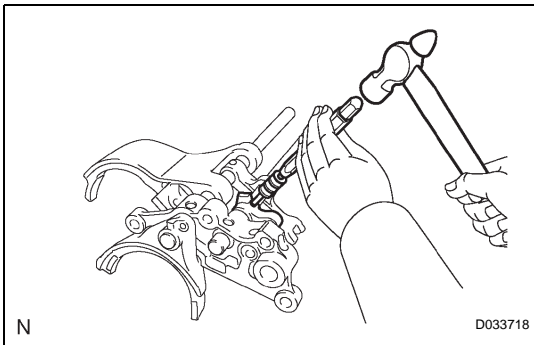
**32. REMOVE NO. 1 GEAR SHIFT HEAD**

- (a) Using a pin punch (5 mm (0.20 in.)) and hammer, tap out the slotted pin.

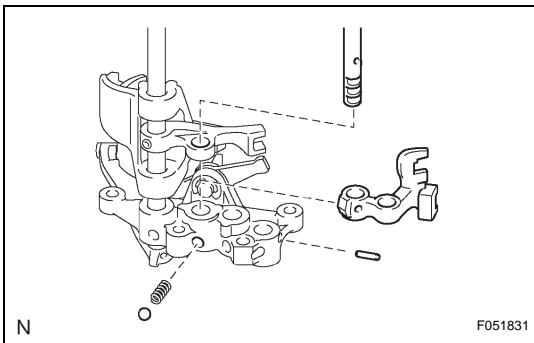
**33. REMOVE NO. 1 GEAR SHIFT FORK SHAFT**

- (a) Remove the shift fork shaft No. 1, ball, spring, shift head No. 1 and interlock pin No. 1.

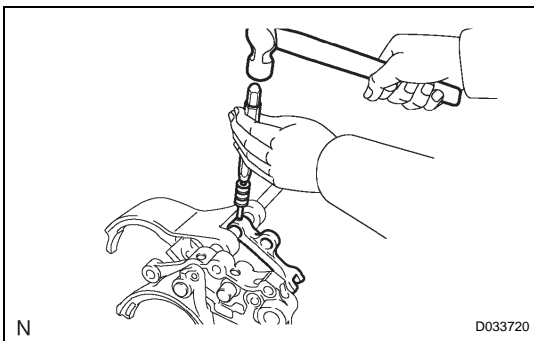
**34. REMOVE NO. 1 GEAR SHIFT FORK**

- (a) Using a pin punch (5 mm (0.20 in.)) and hammer, tap out the slotted pin.

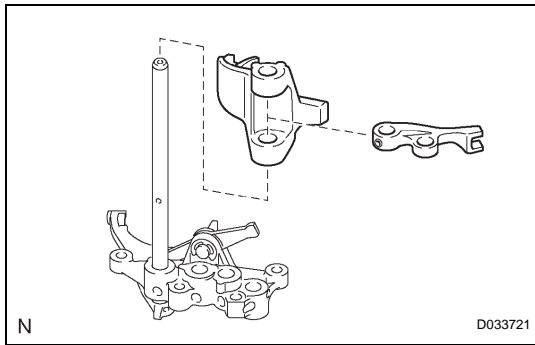

(b) Remove the shift head No. 2 and shift fork No. 1.

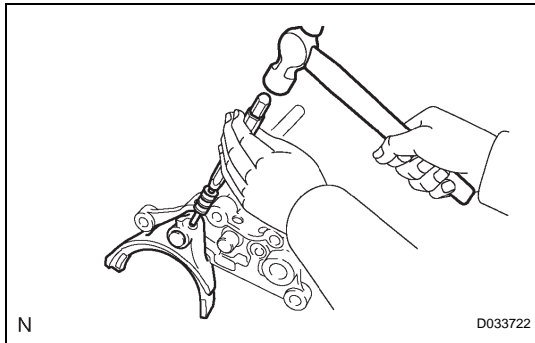

35. REMOVE NO. 4 GEAR SHIFT FORK

- (a) Using a pin punch (5 mm (0.20 in.)) and hammer, tap out the slotted pin.
- (b) Remove the shift fork No. 4.

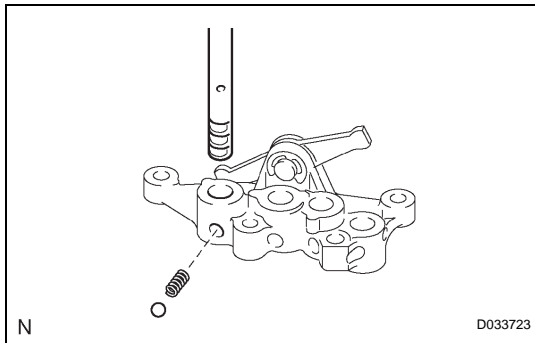

36. REMOVE NO. 4 GEAR SHIFT FORK SHAFT

- (a) Remove the shift fork shaft No. 4, ball and spring.

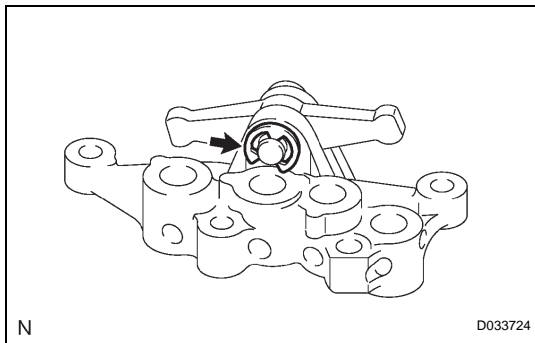

37. REMOVE 1ST AND REVERSE SHIFT ARM

- (a) Using a screwdriver, remove the E-ring.

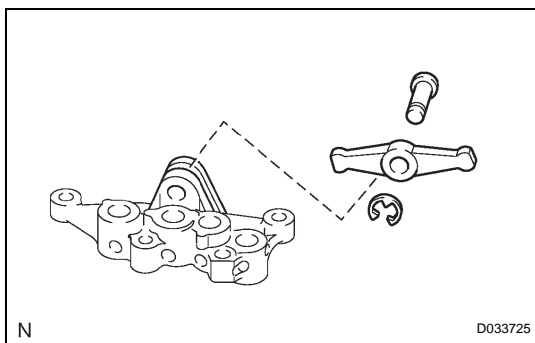

- (b) Remove the shift arm pivot and shift arm.

MT