

OUTPUT SHAFT COMPONENTS

MT

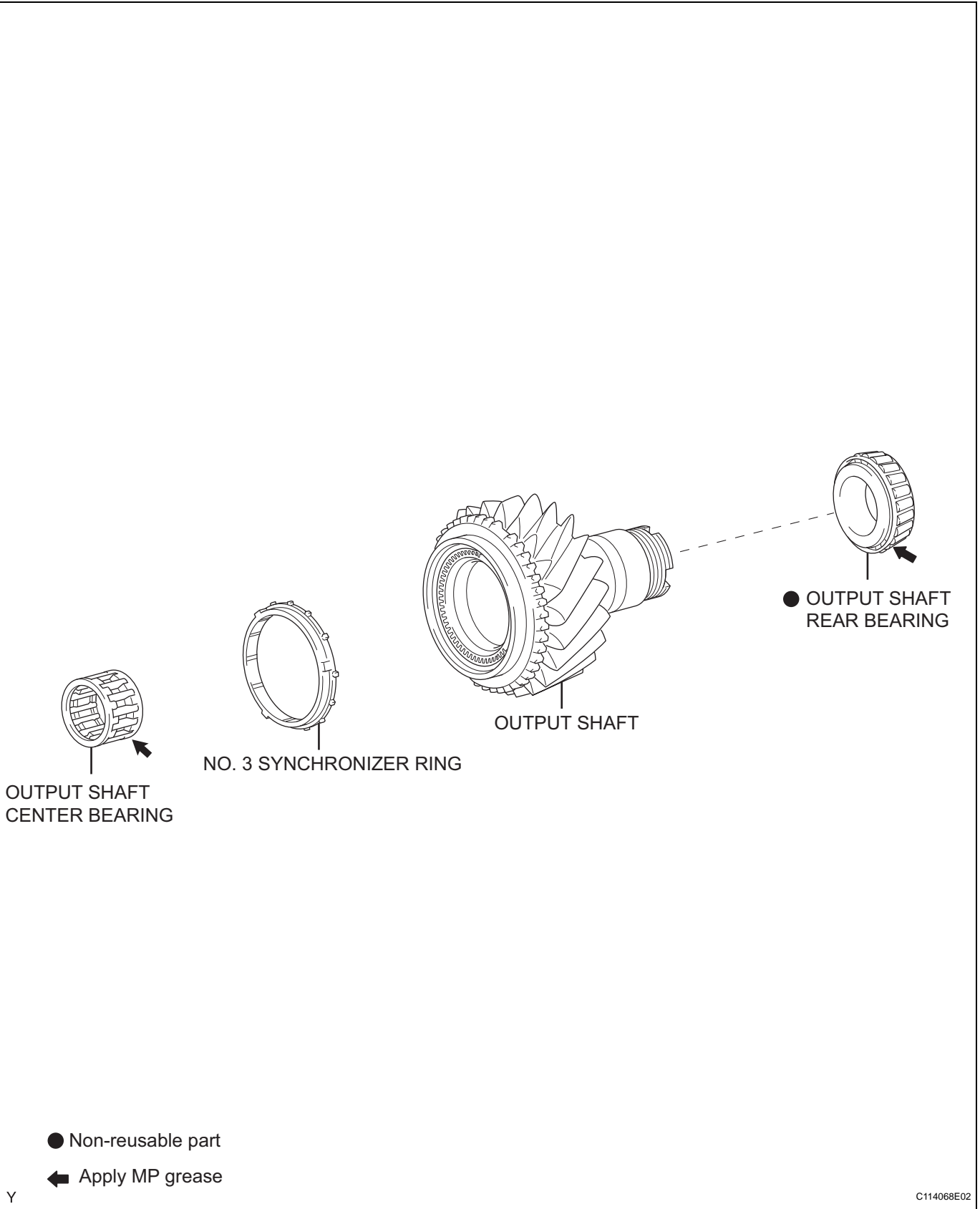

DISASSEMBLY

1. **REMOVE NO. 3 SYNCHRONIZER RING**
 - (a) Remove synchronizer ring No. 3 from the output shaft.
2. **REMOVE OUTPUT SHAFT CENTER BEARING**
 - (a) Remove the output shaft center bearing from the output shaft.
3. **REMOVE OUTPUT SHAFT REAR BEARING**
 - (a) Using SST and a press, remove the output shaft rear bearing from the output shaft.
SST 09950-00020, 09950-70010 (09951-07100), 09950-60010 (09951-00510)

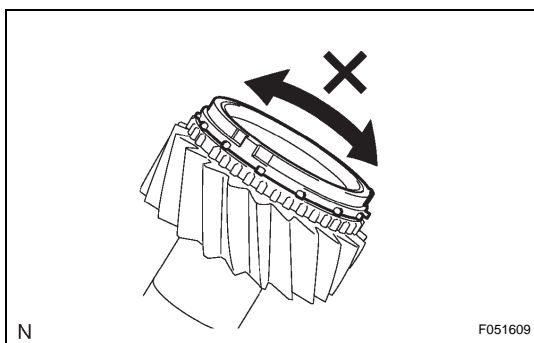
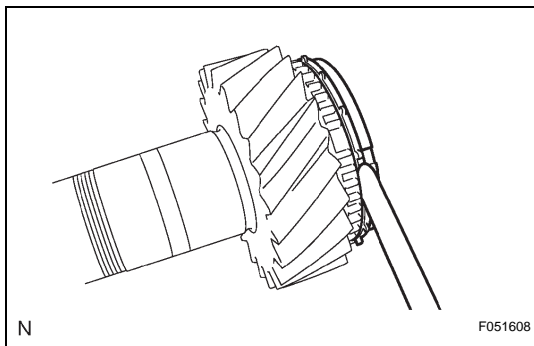
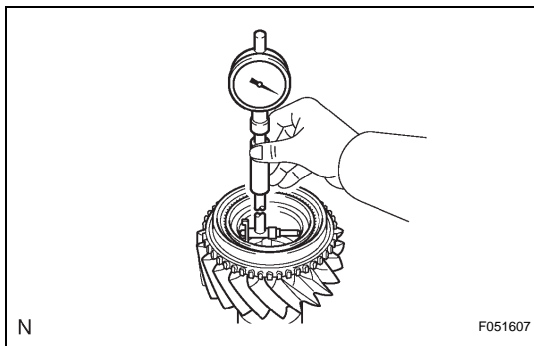
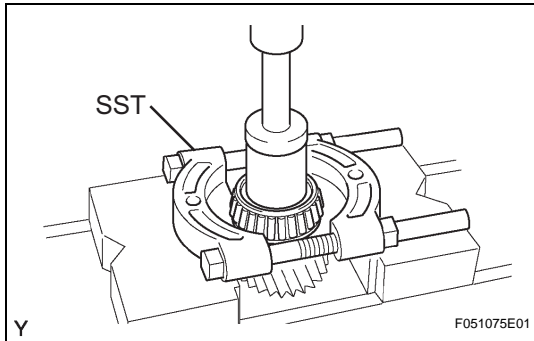

INSPECTION

1. **INSPECT OUTPUT SHAFT**
 - (a) Using a cylinder gauge, measure the inside diameter of the output shaft.
Standard inside diameter:
 45.009 to 45.025 mm (1.7720 to 1.7726 in.)
Maximum inside diameter:
 45.025 mm (1.7726 in.)
 If the diameter exceeds the maximum, replace the output shaft.
2. **INSPECT NO. 3 SYNCHRONIZER RING**
 - (a) Using a feeler gauge, measure the clearance between the synchronizer ring and gear spline.
Standard clearance:
 0.70 to 1.50 mm (0.0276 to 0.0591 in.)
Minimum clearance:
 0.70 mm (0.0276 in.)
 If the clearance is less than the minimum, replace the synchronizer ring.
 - (b) Coat the output shaft and synchronizer ring cone with gear oil. Check the braking effect of the synchronizer ring. Turn the synchronizer ring in one direction while pushing it to the gear cone. Check that the ring locks.