

DISASSEMBLY

1. INSPECT FRONT PROPELLER SHAFT UNIVERSAL JOINT SPIDER BEARING

- (a) Check the spider bearings for wear and damage.
- (b) Check each spider bearing's axial play by turning the yoke while holding the shaft tightly.

Maximum bearing axial play:
0 to 0.05 mm (0 to 0.002 in.)

2. REMOVE FRONT PROPELLER SHAFT UNIVERSAL JOINT SPIDER BEARING

- (a) Place matchmarks on the propeller shaft and flange yoke.

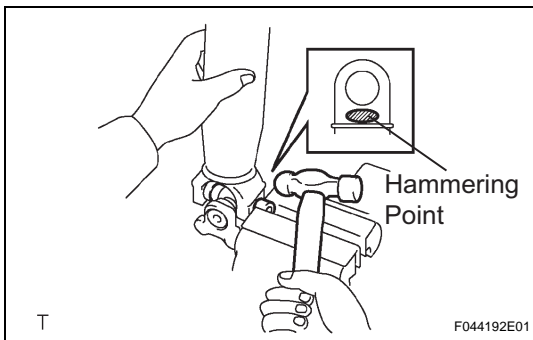
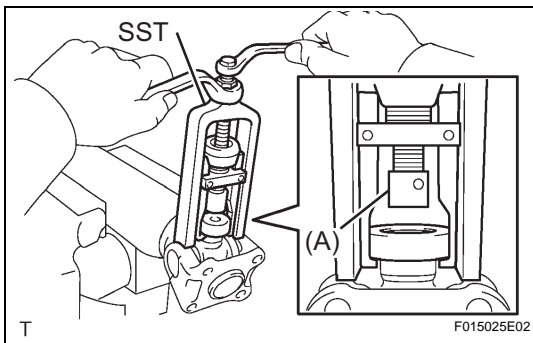
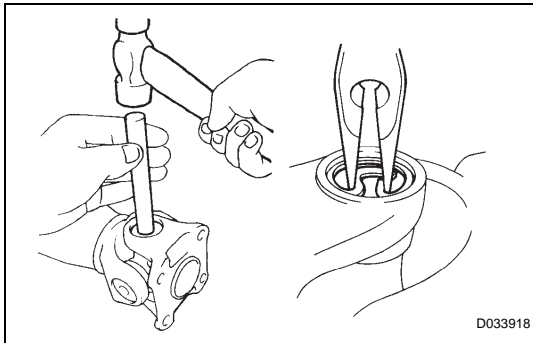
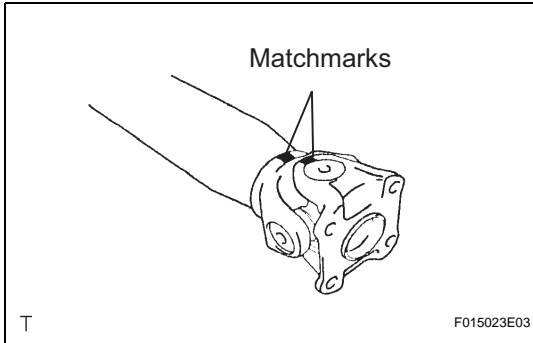

- (b) Using a brass bar and a hammer, slightly tap in the spider bearing outer races.
- (c) Using needle-nose pliers, remove the 4 snap rings from the grooves.

- (d) Using SST, push the spider bearing out of the propeller shaft.

SST 09332-25010

HINT:

Sufficiently raise the part indicated by (A) so that it does not come into contact with the spider bearing.

- (e) Clamp the spider bearing outer race in a vise and tap off the propeller shaft with a hammer.

HINT:

Remove the bearing on the opposite side in the same procedure.

NOTICE:

Do not tap the shaft.

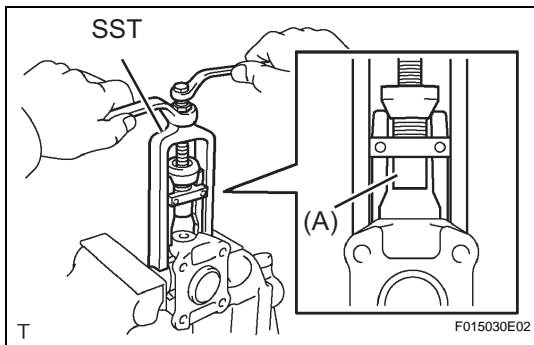

- (f) Install the 2 removed spider bearing outer races onto the spider, and clamp them in a vise.
- (g) Using SST, push the bearing out of the yoke.

SST 09332-25010

HINT:

Sufficiently raise the part indicated by (A) so that it does not come into contact with the bearing.

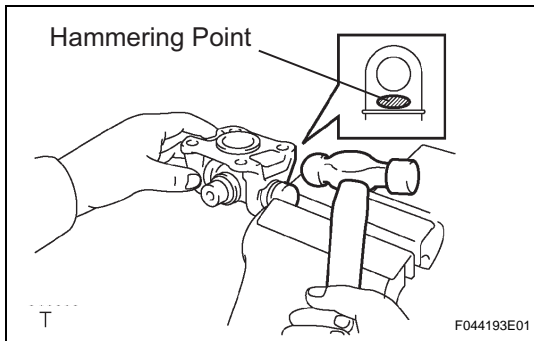

- (h) Clamp the outer bearing race in a vise and tap off the flange yoke with a hammer.
- (i) Remove the spider.

PR

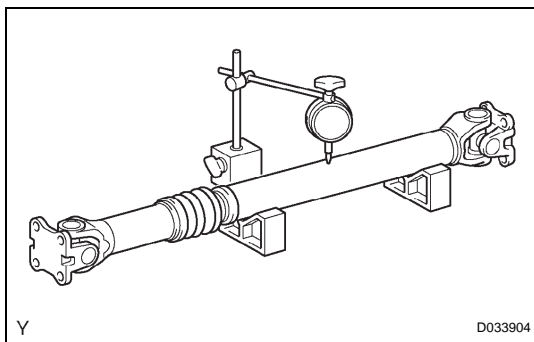

INSPECTION

1. INSPECT FRONT PROPELLER SHAFT ASSEMBLY

- (a) Using a dial indicator, check the propeller shaft runout.

Maximum runout:

0.6 mm (0.024 in.)

If the shaft runout is greater than the maximum, replace the propeller shaft.

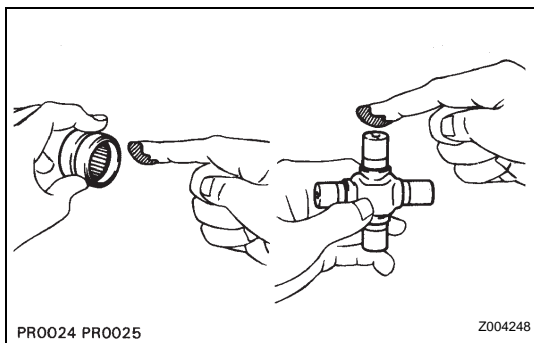

REASSEMBLY

1. INSTALL FRONT PROPELLER SHAFT UNIVERSAL JOINT SPIDER BEARING

- (a) Apply MP grease No. 2 to a new spider and spider bearing.
- (b) Fit the spider into the flange yoke.

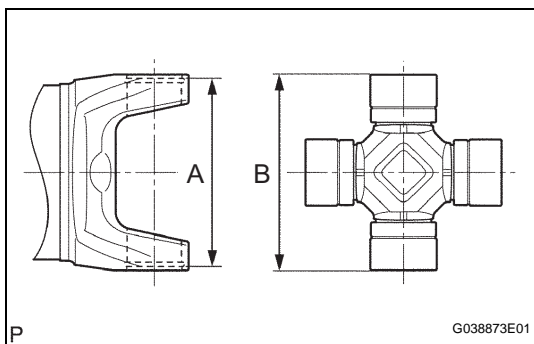

- (c) Measure dimension A between the snap ring grooves.
- (d) Insert the spider bearing into the spider journal portion, and then measure dimension B of the universal joint.

NOTICE:

When measuring dimension B, fix the spider and needle roller bearings in a vise and hold them firmly together.

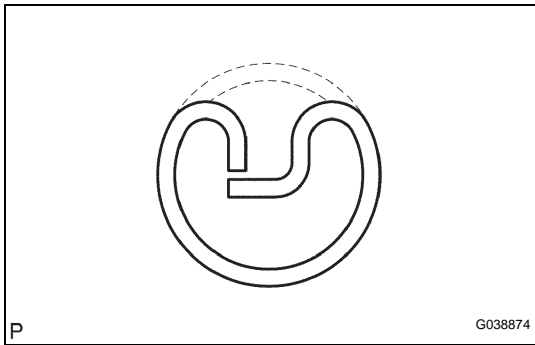

- (e) Select snap rings to make dimensions A and B the same.

Snap Ring Type

Color	Thickness mm (in.)
Green	1.384 (0.0545)
Red	1.435 (0.0565)
Black	1.486 (0.0585)
Copper	1.511 (0.0595)
Silver	1.537 (0.0605)
Yellow	1.588 (0.0625)
Blue	1.638 (0.0645)

NOTICE:

- Use new snap rings.
- If possible, use snap rings of the same thickness for both edges.

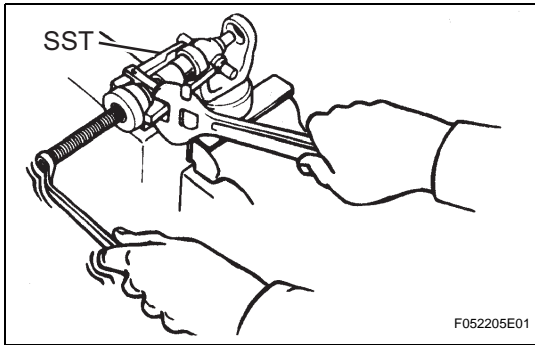

- (f) Insert the spider into the yoke, and then using SST, press in the spider bearing into the snap ring groove.

SST 09332-25010

- (g) Press in the spider bearing on the opposite side in the same way.

NOTICE:

When pressing in the spider bearing, be careful not to damage its lip.

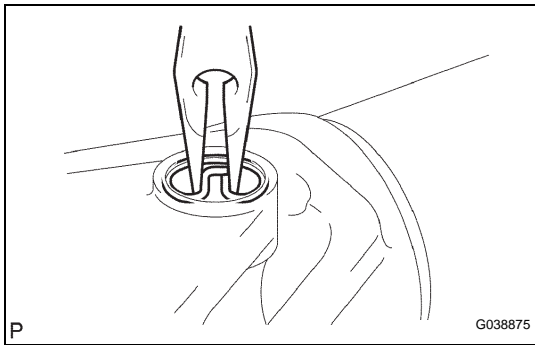

- (h) Using needle-nose pliers, install new snap rings into the grooves of the yoke.

2. INSPECT FRONT PROPELLER SHAFT UNIVERSAL JOINT SPIDER BEARING

- (a) Check the spider bearings for wear and damage.
 (b) Check each spider bearing's axial play by turning the yoke while holding the shaft tightly.

**Maximum bearing axial play:
 0 to 0.05 mm (0 to 0.002 in.)**