

FRONT DIFFERENTIAL CARRIER ASSEMBLY (for 4WD)

COMPONENTS

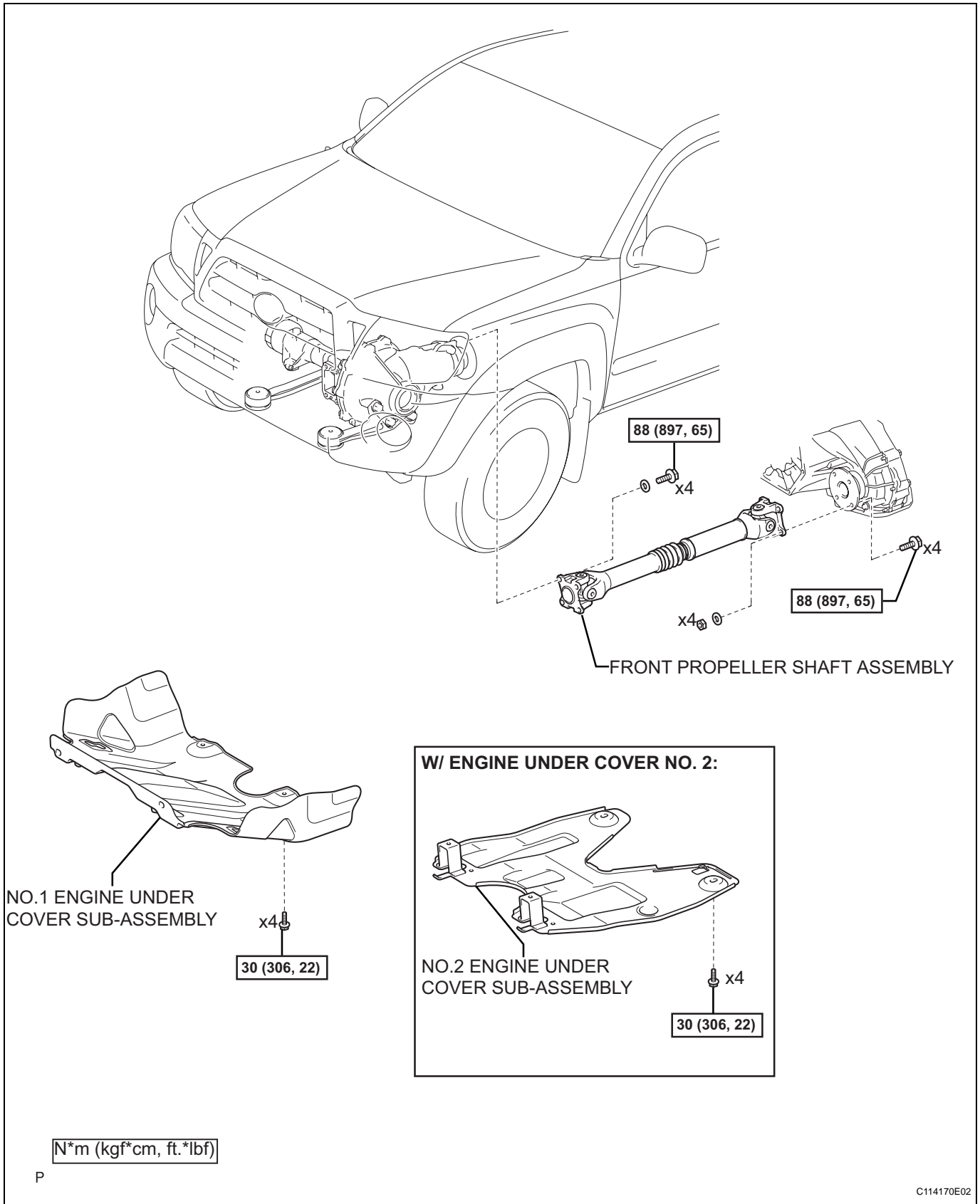

DF

DF

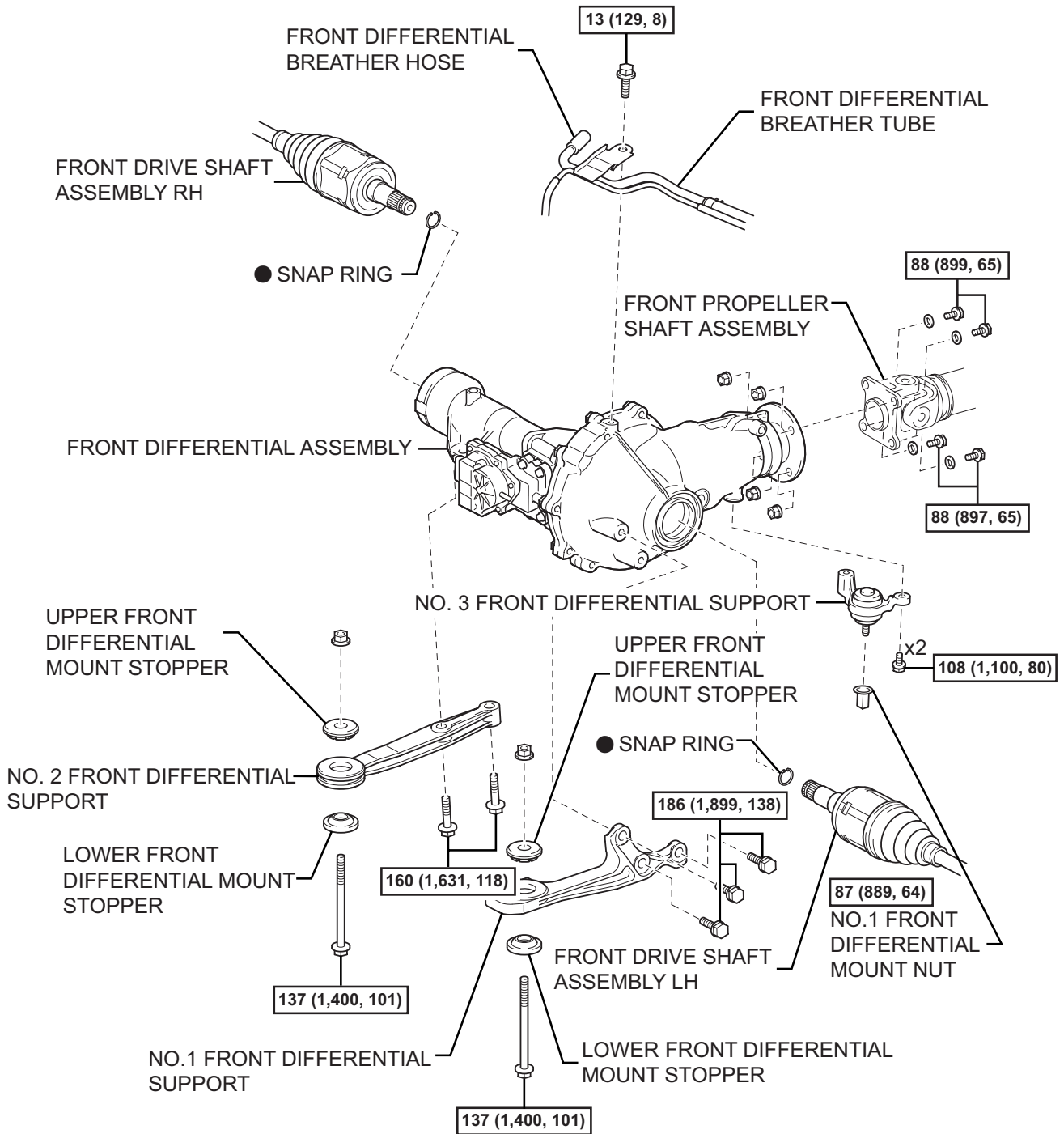

$\boxed{\text{N*m (kgf*cm, ft.*lbf)}}$: Specified torque

● Non-reusable part

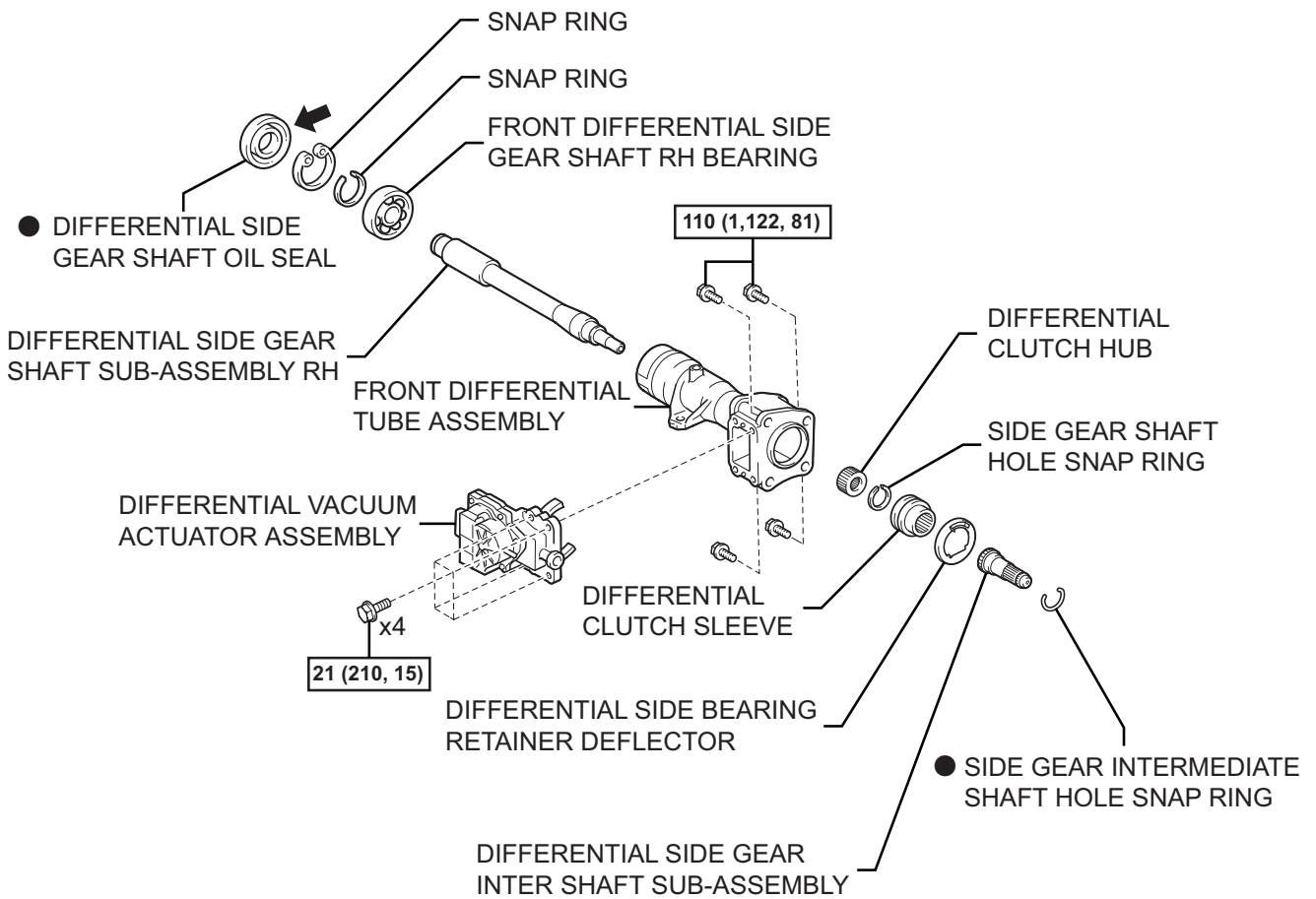

N*m (kgf*cm, ft.*lbf) : Specified torque

● Non-reusable part

← Apply MP grease

DF

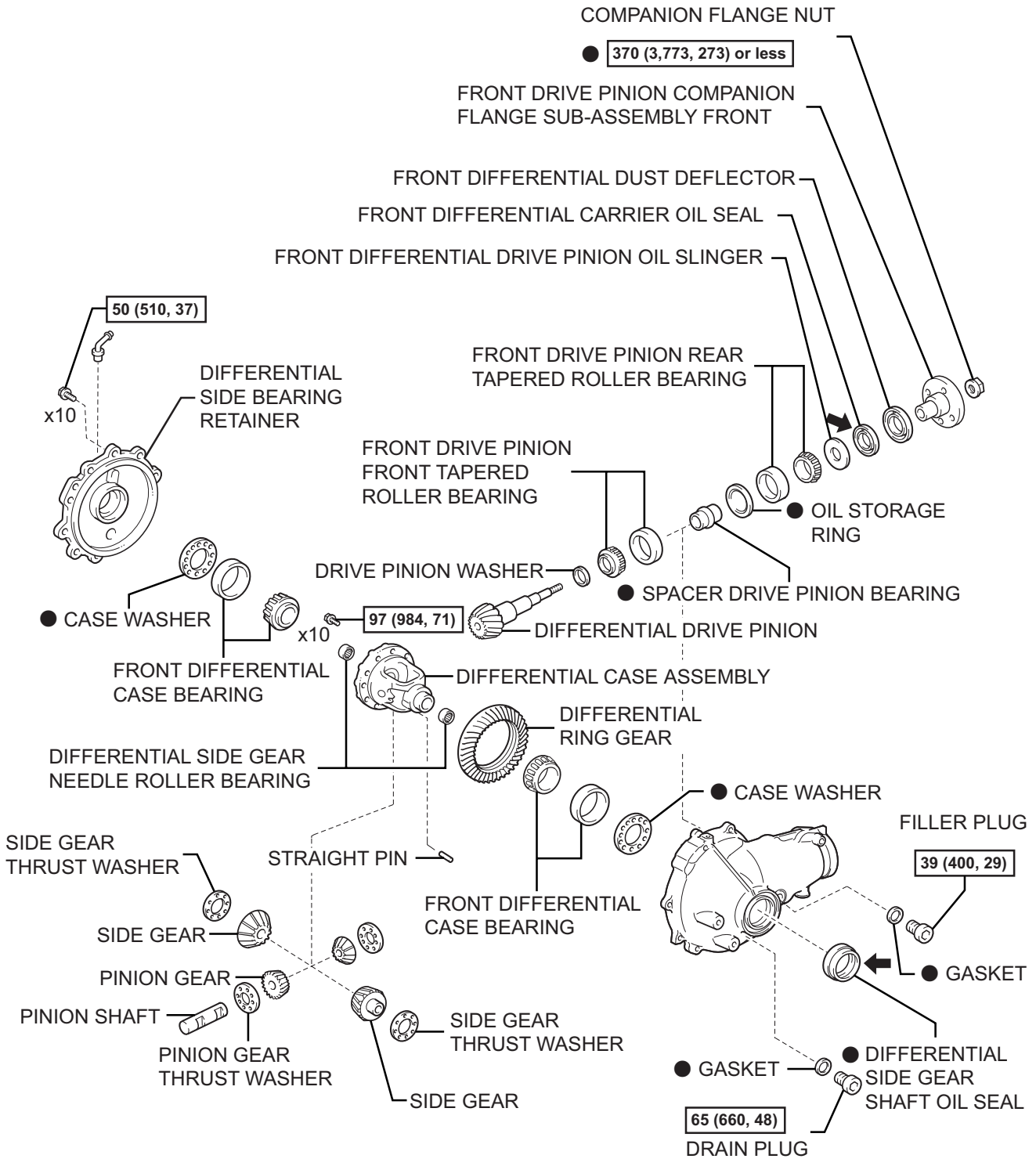

[N*m (kgf*cm, ft.*lbf)] : Specified torque

● Non-reusable part

➡ Apply MP grease