

# FRONT STABILIZER BAR (for 2WD)

## COMPONENTS

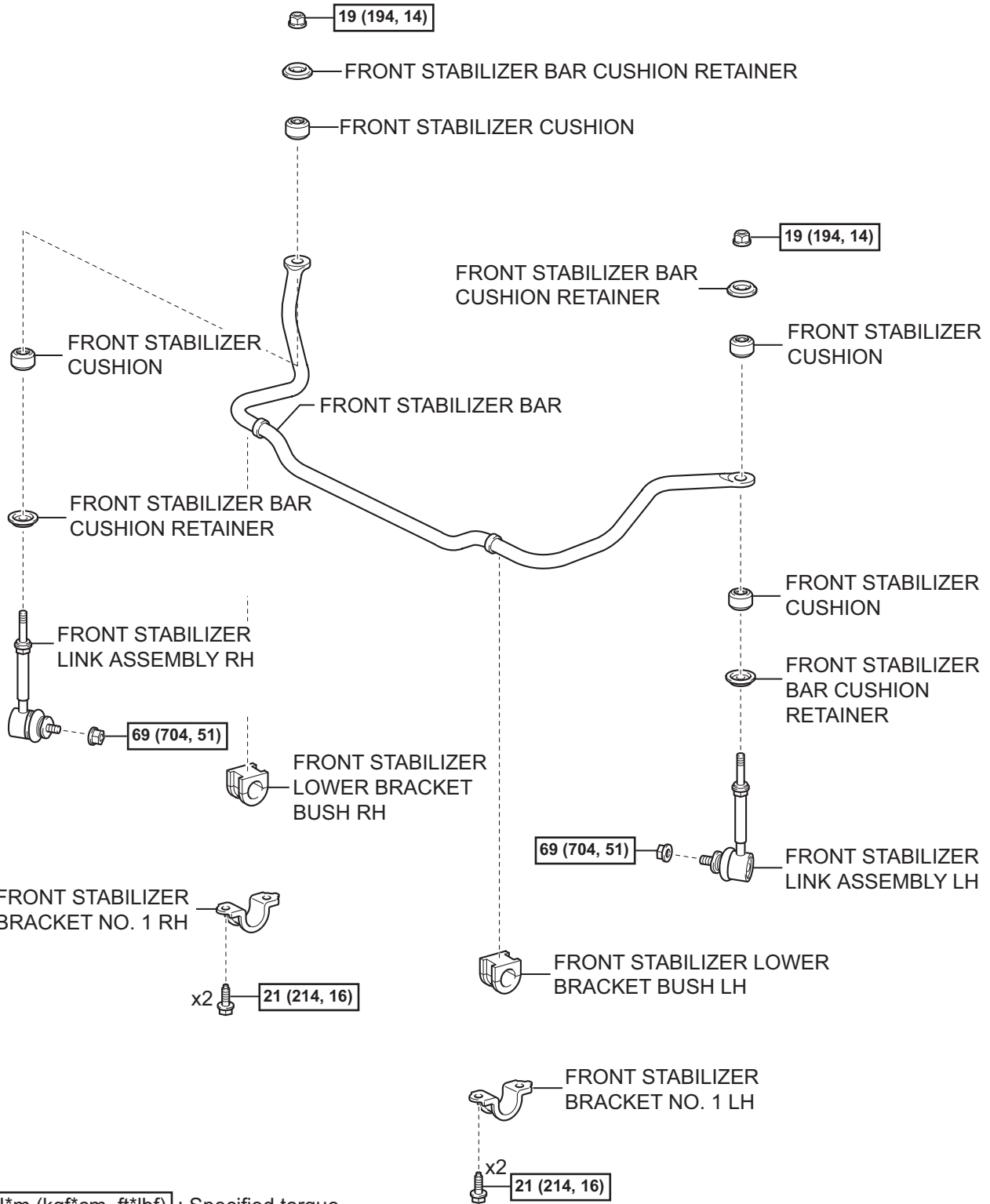

SP

## REMOVAL

1. REMOVE FRONT WHEELS
2. REMOVE FRONT STABILIZER LINK ASSEMBLY LH
  - (a) Remove the 2 nuts, 2 retainers, 2 cushions and the front stabilizer link LH.

HINT:  
If the ball joint turns together with the nut, use a hexagon (6 mm) wrench to hold the stud.

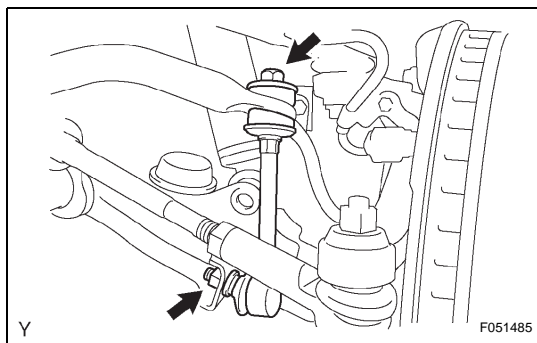

3. REMOVE FRONT STABILIZER LINK ASSEMBLY RH
 

HINT:  
The removal procedure for the RH side is the same as that for the LH side.

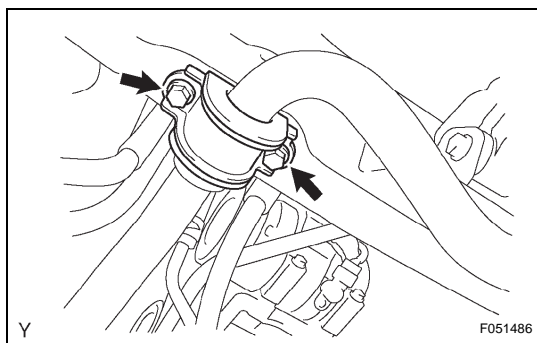

4. REMOVE FRONT STABILIZER BRACKET NO. 1 LH
  - (a) Remove the 2 bolts and front stabilizer bracket.
5. REMOVE FRONT STABILIZER BRACKET NO. 1 RH
 

HINT:  
The removal procedure for the RH side is the same as that for the LH side.

6. REMOVE FRONT STABILIZER LOWER BRACKET BUSH LH
7. REMOVE FRONT STABILIZER LOWER BRACKET BUSH RH

8. REMOVE FRONT STABILIZER BAR

## INSPECTION

1. INSPECT FRONT STABILIZER LINK ASSEMBLY
  - (a) Flip the ball joint stud back and forth 5 times, as shown in the illustration, before installing the nut.
  - (b) Using a torque wrench, turn the nut continuously at a rate of 2 to 4 seconds per turn and take the torque reading on the 5th turn.  
**Torque: 2.0 N\*m (20 kgf\*cm, 18 in.\*lbf)**
  - (c) Check for any cracks and grease leakage on the ball joint dust cover.

