

<b>DTC</b>	<b>C0273/13</b>	<b>Open or Short Circuit in ABS Motor Relay Circuit</b>
------------	-----------------	---

<b>DTC</b>	<b>C0274/14</b>	<b>Short to B+ in ABS Motor Relay Circuit</b>
------------	-----------------	---

**DESCRIPTION**

The ABS motor relay supplies power to the ABS pump motor. While the ABS is activated, the skid control ECU switches the motor relay ON and operates the ABS pump motor.

DTC No.	DTC Detecting Conditions	Trouble Areas
C0273/13	When either of following (1 or 2) detected: 1. Both of following conditions continue for at least 0.2 seconds. • IG1 voltage between 9.5 and 17.2 V. • Relay contact open when relay ON. 2. Both of following conditions continue for at least 0.2 seconds. • IG1 voltage less than 9.5 V. • Relay contact remains open when relay ON.	<ul style="list-style-type: none"> <li>• ABS motor relay</li> <li>• ABS motor relay circuit</li> </ul>
C0274/14	The following condition continues for at least 4 seconds. • Relay contact closed when relay OFF.	<ul style="list-style-type: none"> <li>• ABS motor relay</li> <li>• ABS motor relay circuit</li> </ul>

**WIRING DIAGRAM**

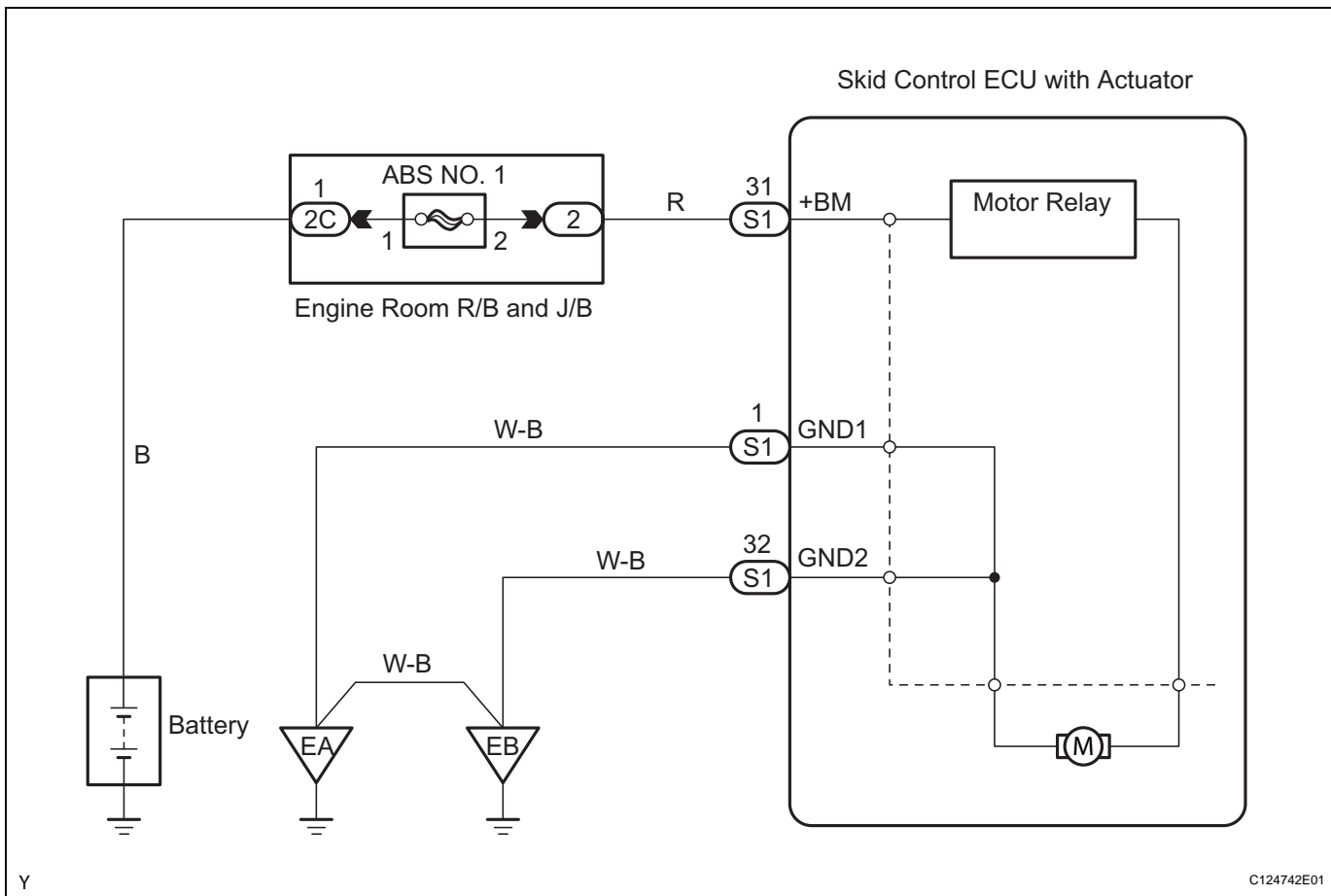

**1 PERFORM ACTIVE TEST BY INTELLIGENT TESTER (ABS MOTOR RELAY)**

- (a) Connect the intelligent tester to the DLC3.
- (b) Turn the ignition switch to the ON position.
- (c) Turn the intelligent tester ON.
- (d) Select the DATA LIST mode on the intelligent tester.
- (e) Check the operation sound of the ABS motor when operating it with the intelligent tester.

Item	Vehicle Condition / Test Details	Diagnostic Note
ABS MOT RELAY	Turns ABS motor relay ON/OFF	Operation of motor can be heard

**OK:**  
The operation sound of the ABS motor should be heard.

**NG** → **Go to step 3**

**OK**

**2 RECONFIRM DTC**

- (a) Clear the DTCs (See page BC-16).
- (b) Drive the vehicle at 6mph (10 km/h) or more to activate initial check.
- (c) Check if the same DTCs are detected.

Result	Proceed to
DTC output	A
DTC not output	B

**BC**

**B** → **END**

**A**

**3 INSPECT SKID CONTROL ECU TERMINAL VOLTAGE (BM+ - GND1, GND2)**

Skid Control ECU (harness side connector):

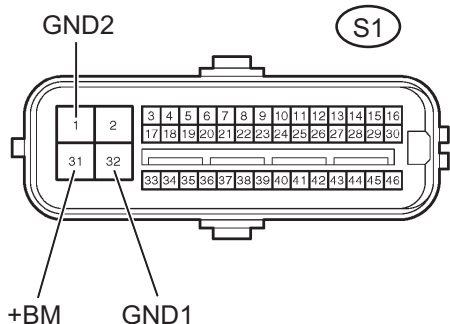

C121700E12

- (a) Disconnect the skid control ECU connector.
- (b) Measure the voltage.

**Standard Voltage**

Tester Connection	Condition	Specified Condition
S1-31 (+BM) - S1-1, 32 (GND1, GND2)	Always	10 to 14 V

- (c) Reconnect the skid control ECU connector.

**NG** → **REPAIR OR REPLACE HARNESS OR CONNECTOR**

OK

REPLACE BRAKE ACTUATOR