

HYDRAULIC BRAKE BOOSTER (w/ VSC)

COMPONENTS

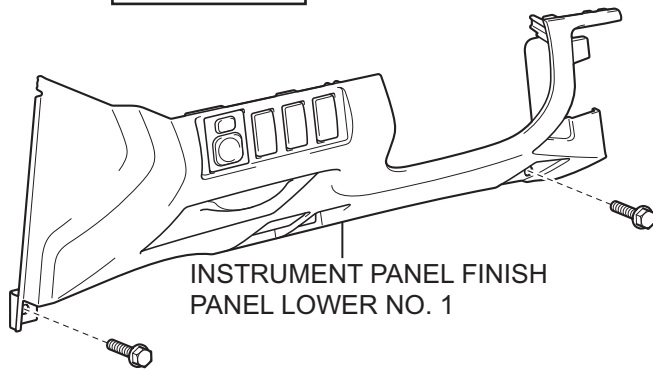

for Automatic Transmission:

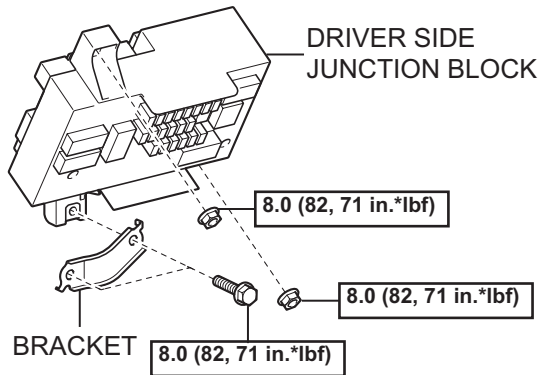

INSTRUMENT PANEL UNDER TRAY

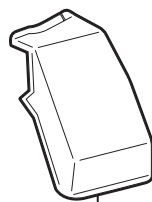
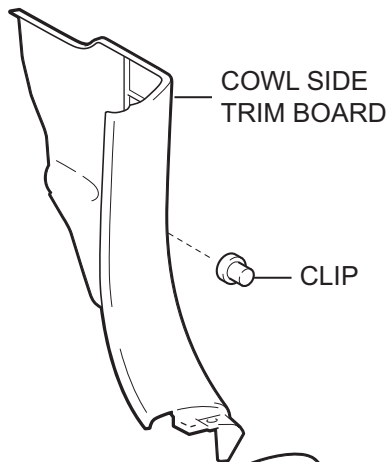

FRONT FLOOR FOOTREST

for Manual Transmission:



INSTRUMENT PANEL HOLE COVER

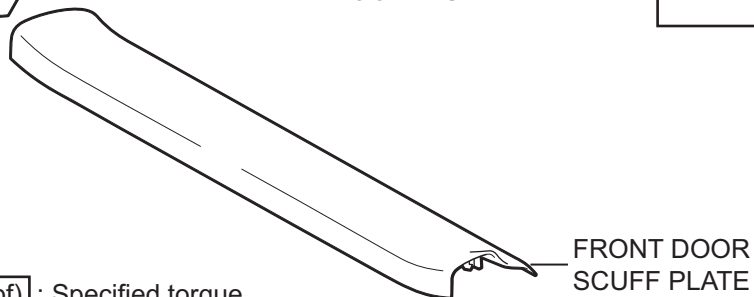

N*m (kgf*cm, ft*lbf) : Specified torque

BR

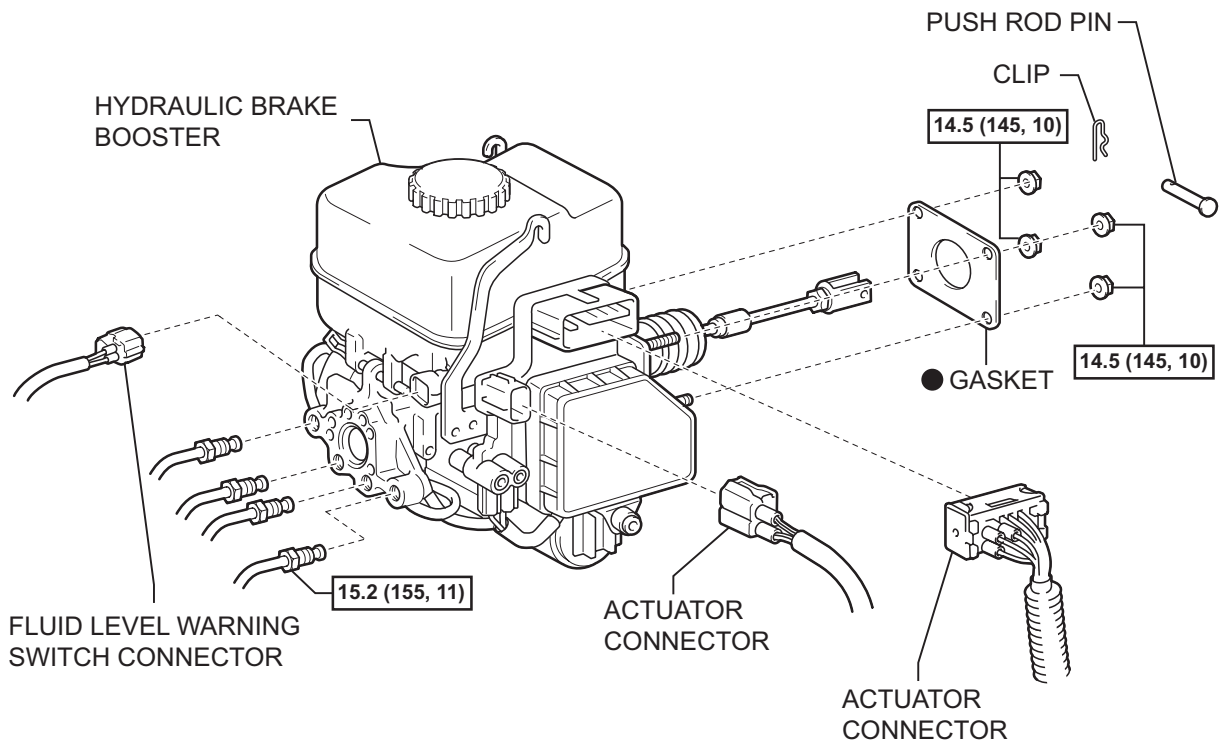

BR

N*m (kgf*cm, ft*lbf) : Specified torque

● Non-reusable part

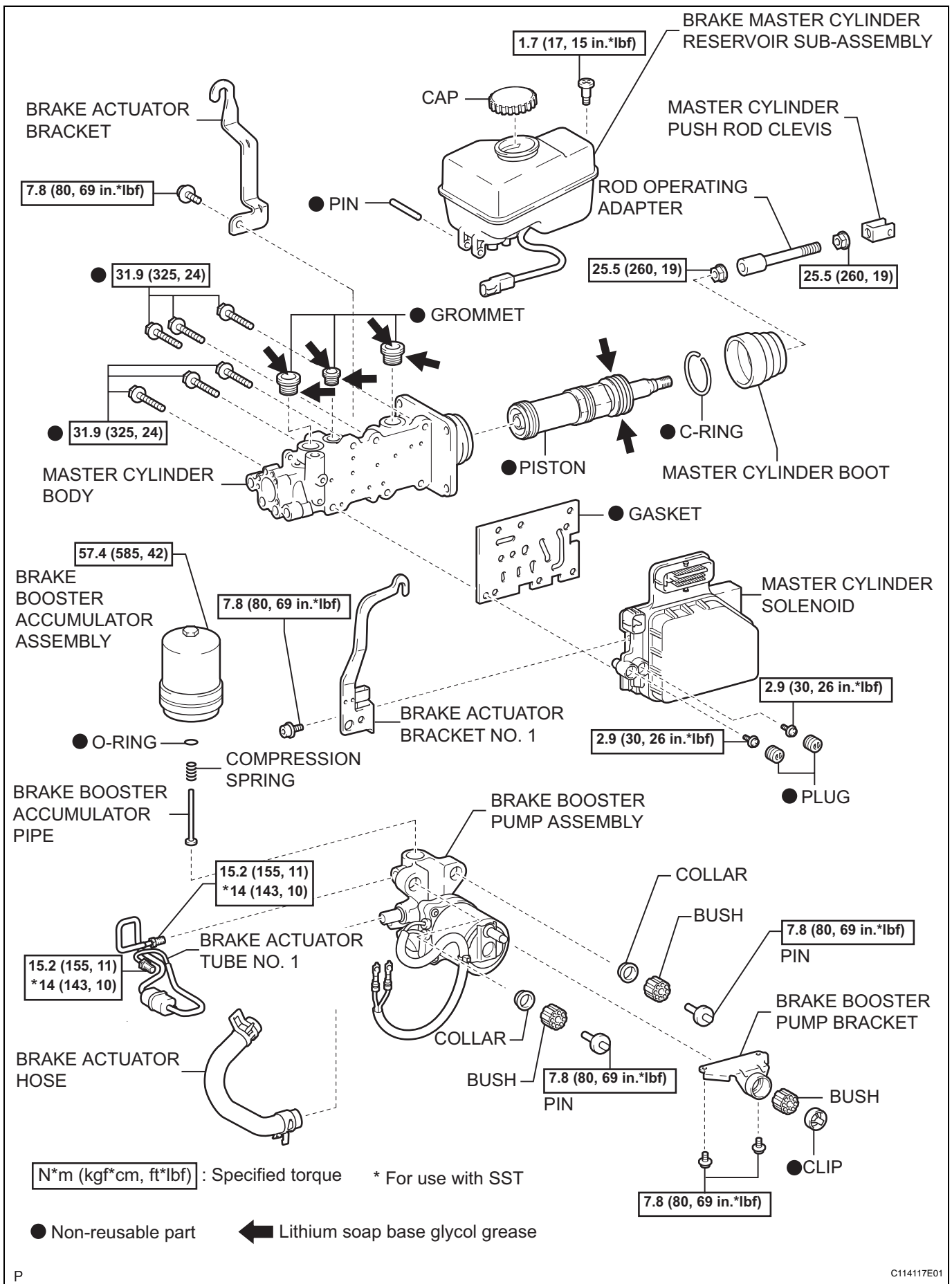

BR