

INSTALLATION

1. **INSTALL PARKING PEDAL PAD**
2. **INSTALL PARKING BRAKE SWITCH ASSEMBLY**
 - (a) Install the parking brake switch assembly with the screw.
3. **INSTALL PARKING BRAKE PEDAL**
 - (a) Install the parking brake control pedal assembly with the 3 nuts.
Torque: 13 N*m (127 kgf*cm, 9 ft.*lbf)
 - (b) Connect the parking brake switch connector.

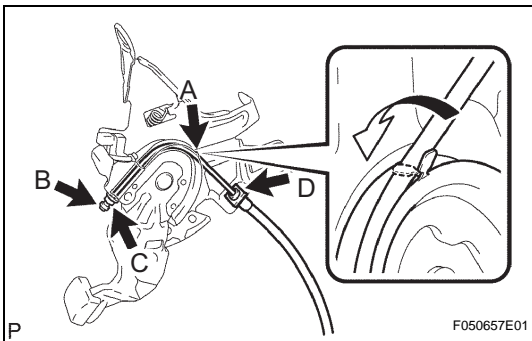
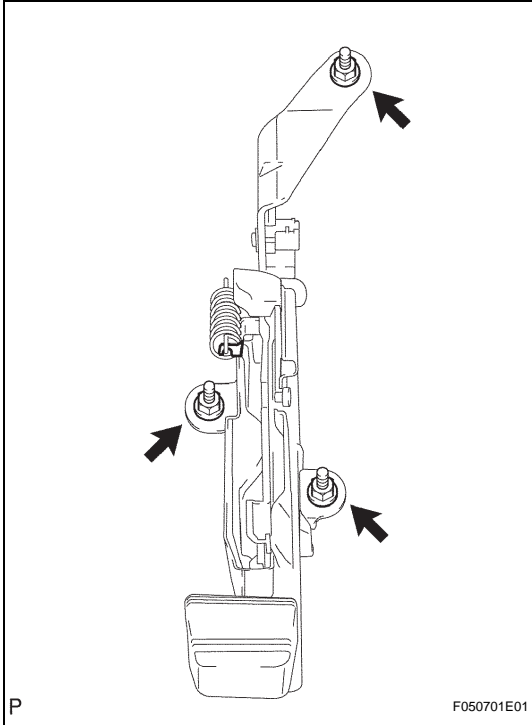

4. **INSTALL PARKING BRAKE CABLE ASSEMBLY NO. 1**
 - (a) Install the parking brake cable assembly No. 1 with the clip D, adjusting nut C and lock nut B.
Torque: 5.4 N*m (55 kgf*cm, 48 in.*lbf)
 - (b) Bend the claw A.
5. **CONNECT CABLE TO NEGATIVE BATTERY TERMINAL**
Torque: 3.9 N*m (40 kgf*cm, 35 in.*lbf)
(See page [IN-5](#))
6. **INSPECT PARKING BRAKE PEDAL TRAVEL** (See page [PB-1](#))
7. **ADJUST PARKING BRAKE PEDAL TRAVEL** (See page [PB-2](#))