

REFRIGERANT LINE

COMPONENTS

for 1GR-FE:

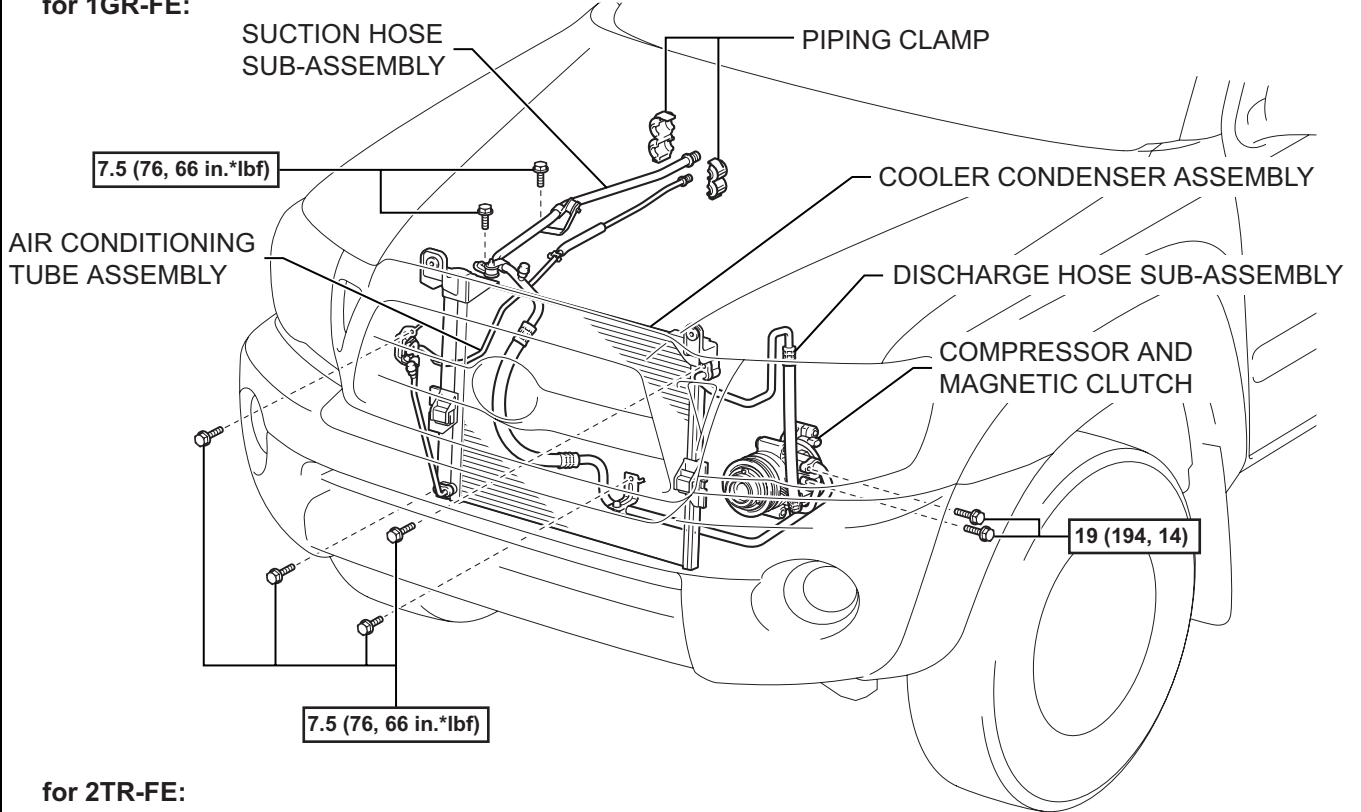

for 2TR-FE:

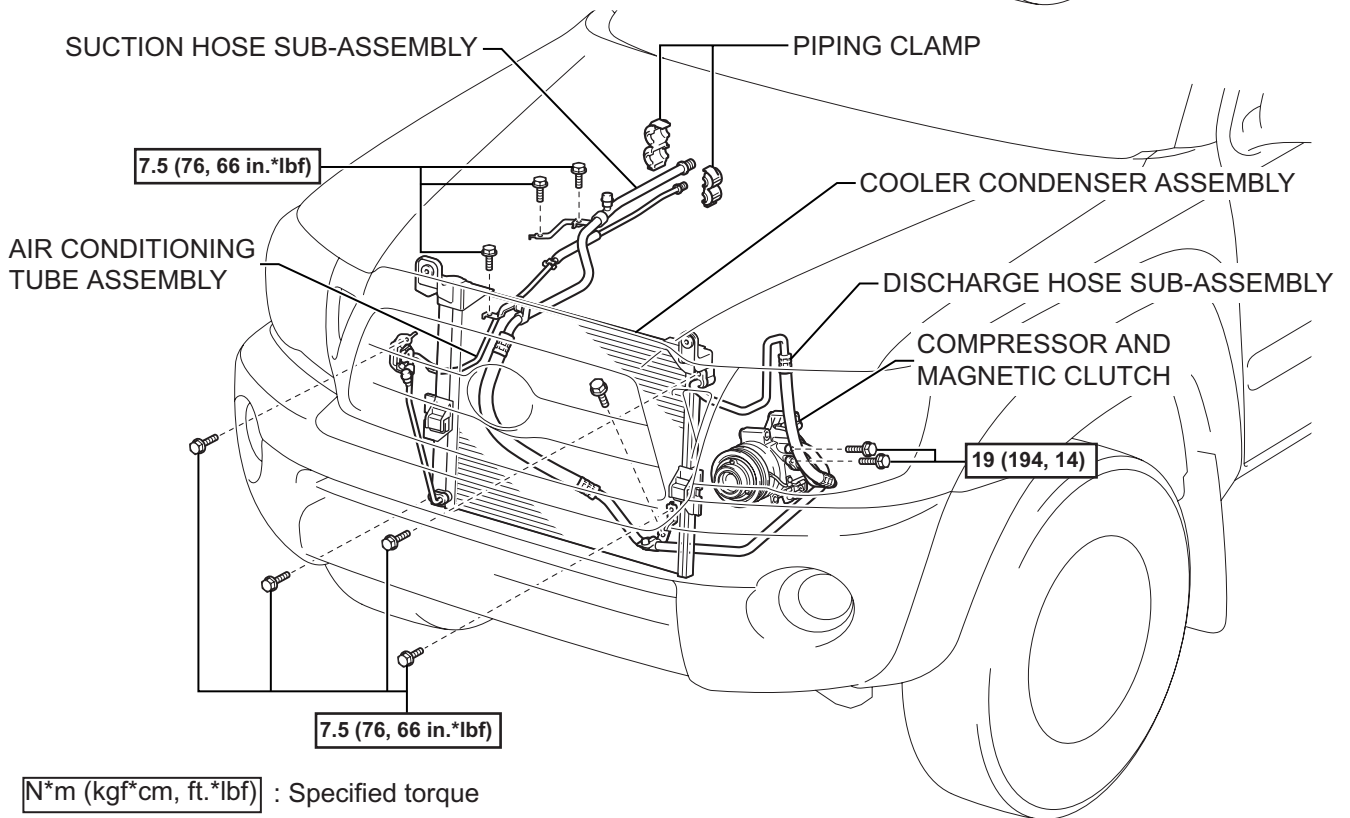

N*m (kgf*cm, ft.*lbf) : Specified torque