

DTC	B1782	Rear Occupant Classification Sensor LH Circuit Malfunction
------------	--------------	---

DESCRIPTION

The rear occupant classification sensor LH circuit consists of the occupant classification ECU and the rear occupant classification sensor LH.

DTC B1782 is set when a malfunction is detected in the rear occupant classification sensor LH circuit.

DTC No.	DTC Detecting Conditions	Trouble Areas
B1782	<ul style="list-style-type: none"> • The occupant classification ECU receives a line short circuit signal, an open circuit signal, a short circuit to ground signal or a short circuit to B+ signal in the rear occupant classification sensor LH circuit for 2 seconds • Rear occupant classification sensor LH malfunction • Occupant classification ECU malfunction 	<ul style="list-style-type: none"> • Front seat with adjuster frame assembly RH (Rear occupant classification sensor LH) • No. 1 seat wire • Occupant classification ECU

HINT:

- When DTC B1650/32 is detected as a result of troubleshooting the supplemental restraint system, perform troubleshooting for DTC B1782 of the occupant classification system.
- Use the intelligent tester to check for DTCs of the occupant classification ECU, otherwise the DTCs cannot be read.

WIRING DIAGRAM

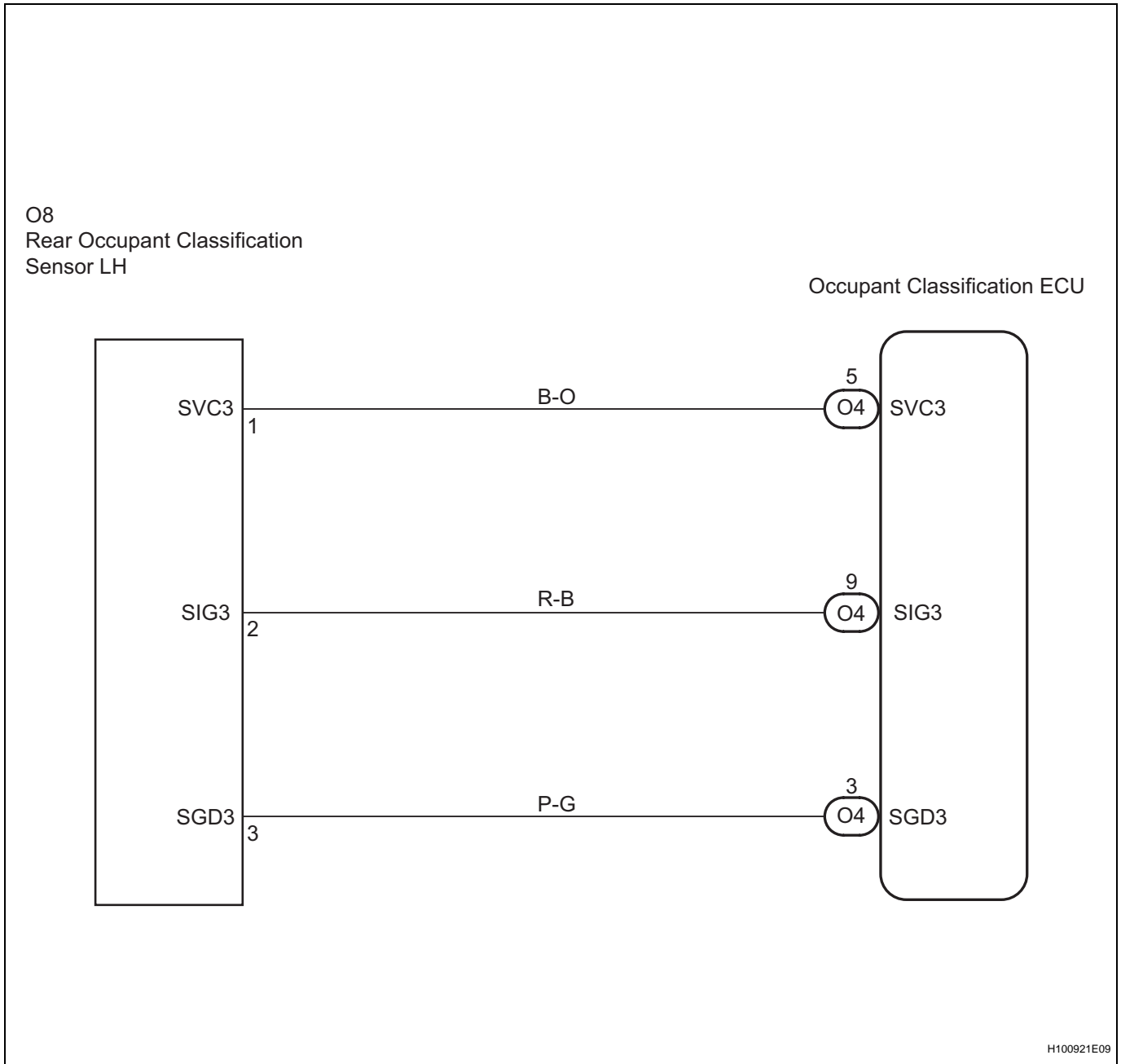

RS

HINT:

- If troubleshooting (wire harness inspection) is difficult to perform, remove the front RH seat assembly installation bolts to see the under surface of the seat cushion.
- In the above case, hold the seat so that it does not fall down. Holding the seat for a long period of time may cause problems, such as seat rail deformation. Hold the seat up only for as long as necessary.

1	CHECK DTC
----------	------------------

- (a) Turn the ignition switch to the ON position.
- (b) Clear any DTCs stored in the memory (See page [RS-365](#)).

HINT:

- First clear DTCs stored in the occupant classification ECU and then in the center airbag sensor assembly.
 - Use the intelligent tester to clear the DTCs of the occupant classification ECU, otherwise the DTCs cannot be cleared.
- (c) Turn the ignition switch to the LOCK position.
 (d) Turn the ignition switch to the ON position.
 (e) Using the intelligent tester, check for DTCs of the occupant classification ECU (See page [RS-365](#)).

OK:

DTC B1782 is not output.

HINT:

DTCs other than B1782 may be output at this time, but they are not related to this check.

OK

USE SIMULATION METHOD TO CHECK

NG

2

CHECK CONNECTION OF CONNECTORS

- (a) Turn the ignition switch to the LOCK position.
 (b) Disconnect the negative (-) terminal cable from the battery, and wait for at least 90 seconds.
 (c) Check that the connectors are properly connected to the occupant classification ECU and the rear occupant classification sensor LH.

OK:

The connectors are properly connected.

NG

CONNECT CONNECTORS

OK

3

REPAIR CONNECTORS

- (a) Check that the connectors (on the occupant classification ECU side and rear occupant classification sensor LH side) are not damaged (See page [IN-34](#)).

OK:

The connectors are not deformed or damaged.

NG

REPAIR OR REPLACE WIRE HARNESS

OK

4 CHECK NO. 1 SEAT WIRE (TO B+)

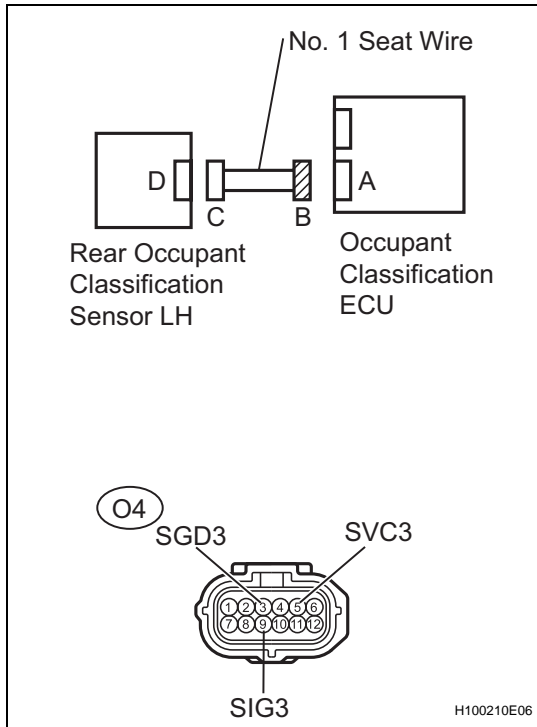

- Disconnect the connectors from the occupant classification ECU and the rear occupant classification sensor LH.
- Connect the negative (-) terminal cable to the battery.
- Turn the ignition switch to the ON position.
- Measure the voltage.

Standard voltage

Tester Connection	Condition	Specified Condition
O4-3 (SGD3) - Body ground	Ignition switch ON	Below 1 V
O4-5 (SVC3) - Body ground	Ignition switch ON	Below 1 V
O4-9 (SIG3) - Body ground	Ignition switch ON	Below 1 V

NG REPAIR OR REPLACE NO. 1 SEAT WIRE

OK

5 CHECK NO. 1 SEAT WIRE (FOR OPEN)

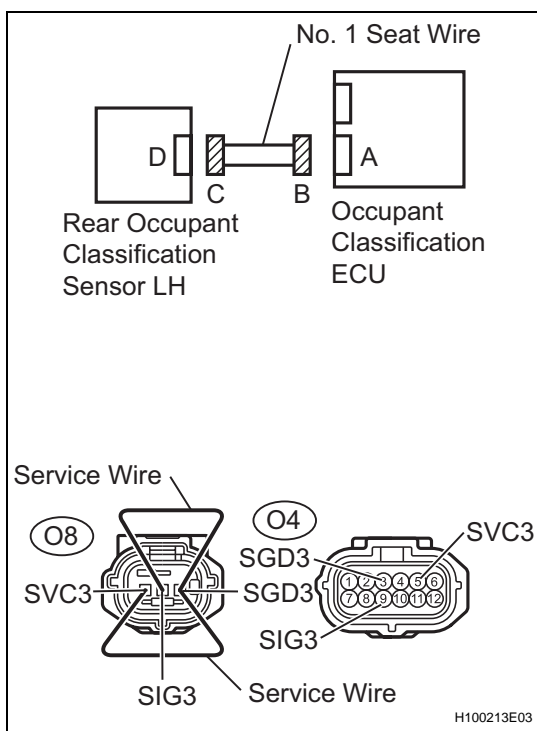

- Turn the ignition switch to the LOCK position.
- Disconnect the negative (-) terminal cable from the battery, and wait for at least 90 seconds.
- Using service wires, connect O8-1 (SVC3) and O8-3 (SGD3), and connect O8-2 (SIG3) and O8-3 (SGD3) of connector C.

HINT:

Do not forcibly insert the service wires into the terminals of the connector when connecting.

- Measure the resistance.

Standard resistance

Tester Connection	Condition	Specified Condition
O4-5 (SVC3) - O4-3 (SGD3)	Always	Below 1 Ω
O4-9 (SIG3) - O4-3 (SGD3)	Always	Below 1 Ω

NG REPAIR OR REPLACE NO. 1 SEAT WIRE

OK

RS

6 CHECK NO. 1 SEAT WIRE (FOR SHORT)

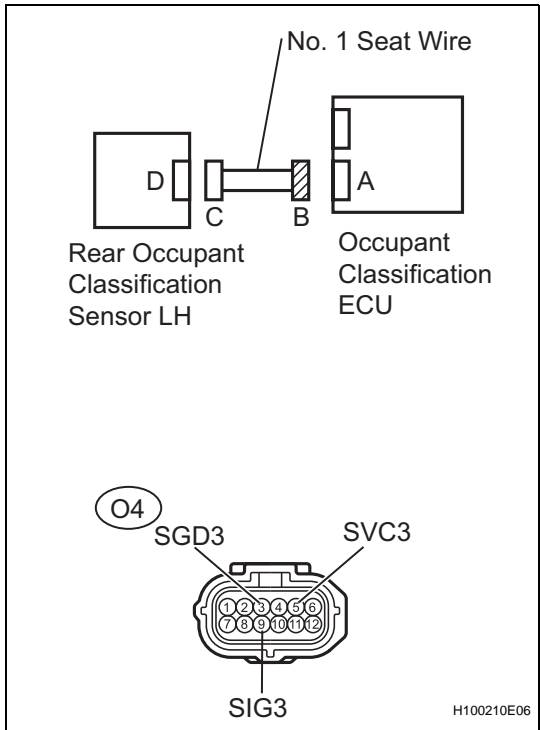

- (a) Disconnect the service wires from connector C.
- (b) Measure the resistance.

Standard resistance

Tester Connection	Condition	Specified Condition
O4-5 (SVC3) - O4-3 (SGD3)	Always	1 MΩ or higher
O4-9 (SIG3) - O4-3 (SGD3)	Always	1 MΩ or higher
O4-5 (SVC3) - O4-9 (SIG3)	Always	1 MΩ or higher

NG REPAIR OR REPLACE NO. 1 SEAT WIRE

OK

7 CHECK NO. 1 SEAT WIRE (TO GROUND)

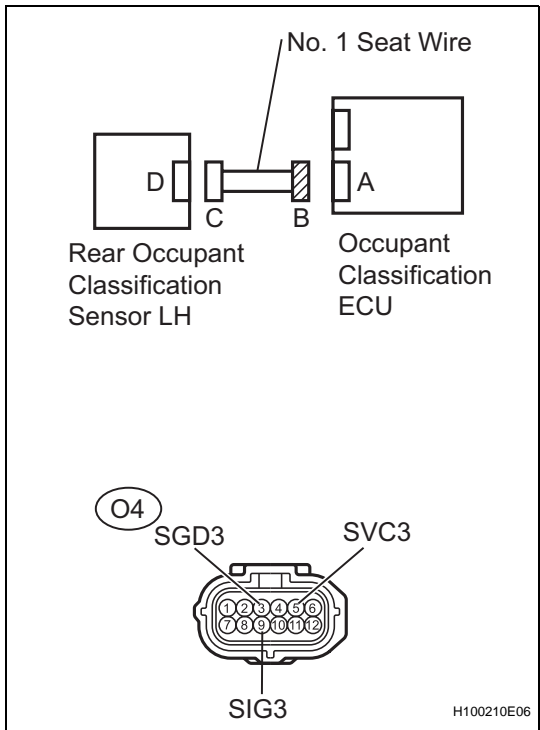

- (a) Measure the resistance.
- Standard resistance**

Tester Connection	Condition	Specified Condition
O4-3 (SGD3) - Body ground	Always	1 MΩ or higher
O4-5 (SVC3) - Body ground	Always	1 MΩ or higher
O4-9 (SIG3) - Body ground	Always	1 MΩ or higher

NG REPAIR OR REPLACE NO. 1 SEAT WIRE

OK

RS

8 CHECK DTC

- (a) Connect the connectors to the occupant classification ECU and the rear occupant classification sensor LH.
- (b) Connect the negative (-) terminal cable to the battery.
- (c) Turn the ignition switch to the ON position.
- (d) Clear any DTCs stored in the memory (See page [RS-365](#)).

HINT:

- First clear DTCs stored in the occupant classification ECU and then in the center airbag sensor assembly.
- Use the intelligent tester to clear the DTCs of the occupant classification ECU, otherwise the DTCs cannot be cleared.
- (e) Turn the ignition switch to the LOCK position.
- (f) Turn the ignition switch to the ON position.
- (g) Using the intelligent tester, check for DTCs of the occupant classification ECU (See page [RS-365](#)).

OK:

DTC B1782 is not output.

HINT:

DTCs other than B1782 may be output at this time, but they are not related to this check.

OK

USE SIMULATION METHOD TO CHECK

NG

9 REPLACE OCCUPANT CLASSIFICATION ECU

- (a) Turn the ignition switch to the LOCK position.
- (b) Disconnect the negative (-) terminal cable from the battery, and wait for at least 90 seconds.
- (c) Replace the occupant classification ECU (See page [RS-631](#)).

HINT:

Perform the inspection using parts from a normal vehicle when possible.

NEXT

10 PERFORM ZERO POINT CALIBRATION

- (a) Connect the negative (-) terminal cable to the battery.
- (b) Connect the intelligent tester to the DLC3.
- (c) Turn the ignition switch to the ON position.
- (d) Using the intelligent tester, perform the zero point calibration (See page [RS-357](#)).

OK:

COMPLETED is displayed on the tester.

NG

Go to step 13

OK

11 PERFORM SENSITIVITY CHECK

- (a) Using the intelligent tester, perform the sensitivity check (See page [RS-357](#)).

Standard value:**27 to 33 kg (59.52 to 72.72 lb)**

NG

Go to step 13

OK

12 CHECK DTC

- (a) Connect the negative (-) terminal cable to the battery.
 (b) Turn the ignition switch to the ON position.
 (c) Clear the DTCs stored in the memory (See page [RS-365](#)).

HINT:

- First clear DTCs stored in the occupant classification ECU and then in the center airbag sensor assembly.
 - Use the intelligent tester to clear the DTCs of the occupant classification ECU, otherwise the DTCs cannot be cleared.
- (d) Turn the ignition switch to the LOCK position.
 (e) Turn the ignition switch to the ON position.
 (f) Using the intelligent tester, check for DTCs of the occupant classification ECU (See page [RS-365](#)).

HINT:

DTCs other than B1782 may be output at this time, but they are not related to this check.

OK

USE SIMULATION METHOD TO CHECK

NG

13 REPLACE FRONT SEAT WITH ADJUSTER FRAME ASSEMBLY RH

- (a) Turn the ignition switch to the LOCK position.
 (b) Disconnect the negative (-) terminal cable from the battery, and wait for at least 90 seconds.
 (c) Replace the front seat with adjuster frame assembly RH (See page [SE-38](#)).

NEXT

14 PERFORM ZERO POINT CALIBRATION

- (a) Connect the negative (-) terminal cable to the battery.
 (b) Connect the intelligent tester to the DLC3.
 (c) Turn the ignition switch to the ON position.
 (d) Using the intelligent tester, perform the zero point calibration (See page [RS-357](#)).

OK:
COMPLETED is displayed on the tester.

NEXT

15 PERFORM SENSITIVITY CHECK

- (a) Using the intelligent tester, perform the sensitivity check
(See page [RS-357](#)).

NEXT

USE SIMULATION METHOD TO CHECK