

## DIAGNOSIS SYSTEM

### 1. CHECK DLC3

- (a) The vehicle's ECU uses the ISO 9141-2 for communication protocol. The terminal arrangement of the DLC3 complies with SAE J1962 and matches the ISO 15765-4 format.

Symbols (Terminal No.)	Terminal Description	Condition	Specified Condition
SIL (7) - SG (5)	Bus + line	During transmission	Pulse generation
CG (4) - Body ground	Chassis ground	Always	Below 1 $\Omega$
BAT (16) - Body ground	Battery positive	Always	11 to 14 V

#### HINT:

If the display shows a communication error message when the intelligent tester is connected to the DLC3, the ignition switch is turned to the ON position and the intelligent tester is operated, there is a problem on the vehicle side or tool side.

- If communication is normal when the tool is connected to another vehicle, inspect the DLC3 on the original vehicle.
- If communication is still not possible when the tool is connected to another vehicle, the problem is probably in the tool itself. Consult the Service Department listed in the tool's instruction manual.

### 2. SYMPTOM SIMULATION

#### HINT:

The most difficult case in troubleshooting is when no symptoms occur. In such cases, a thorough customer problem analysis must be carried out. Then the same or similar conditions and environment in which the problem occurred in the customer's vehicle should be simulated. Regardless of the technician's experience or skill, if troubleshooting proceeds without confirmation of the problem symptoms, something important is likely to be overlooked and incorrect assumptions may be made at some points in the repair operation.

This leads to a standstill in troubleshooting.

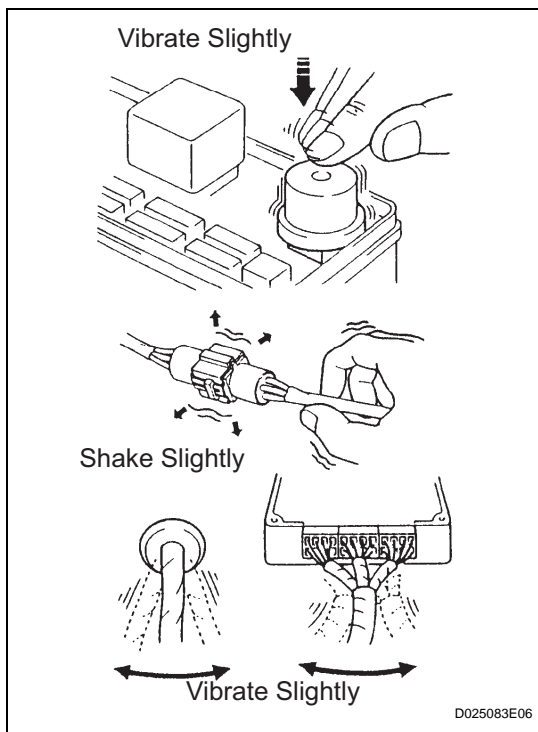

- (a) Vibration method (When vibration seems to be the major cause)  
**HINT:**  
 Perform the simulation method only during the primary check period (for approximately 6 seconds after the ignition switch is turned to the ON position).
- (1) Slightly vibrate the part of the sensor considered to be the cause of the problem with your fingers and check whether the malfunction occurs.  
**HINT:**  
 Shaking the relays too strongly may result in open relays.
  - (2) Slightly shake the connector vertically and horizontally.
  - (3) Slightly shake the wire harness vertically and horizontally.  
 The connector joint and fulcrum of the vibration are the main areas that should be checked thoroughly.

**3. FUNCTION OF PASSENGER AIRBAG ON/OFF INDICATOR**

- (a) Initial check
- (1) Turn the ignition switch to the ON position.
  - (2) The passenger airbag ON/OFF indicator illuminates ON and OFF for approximately 4 seconds, and then turns them off for approximately 2 seconds.
  - (3) Approximately 6 seconds after the ignition switch is turned to the ON position, the passenger airbag ON/OFF indicator indicates ON or OFF depending on the conditions listed below.

Front Seat Passenger	Airbag Cut-off Switch Position	ON Indicator	OFF Indicator	SRS Warning Light
Adult seated	AUTO	ON	OFF	OFF
Adult seated	OFF	OFF	ON	OFF
Adult seated	Airbag cut off switch system failure	OFF	ON	ON
Child seated / Child restrain system set	AUTO	OFF	ON	OFF
Child seated / Child restrain system set	OFF	OFF	ON	OFF
Child seated / Child restrain system set	Airbag cut off switch system failure	OFF	ON	ON
Vacant	AUTO	OFF	OFF	OFF
Vacant	OFF	OFF	ON	OFF
Vacant	Airbag cut off switch system failure	OFF	ON	ON
Passenger occupant classification system failure	AUTO	OFF	ON	ON
Passenger occupant classification system failure	OFF	OFF	ON	ON

Front Seat Passenger	Airbag Cut-off Switch Position	ON Indicator	OFF Indicator	SRS Warning Light
Passenger occupant classification system failure	Airbag cut off switch system failure	OFF	ON	ON

**HINT:**

- The passenger airbag ON/OFF indicator operates based on the timing chart below in order to check the indicator light circuit.

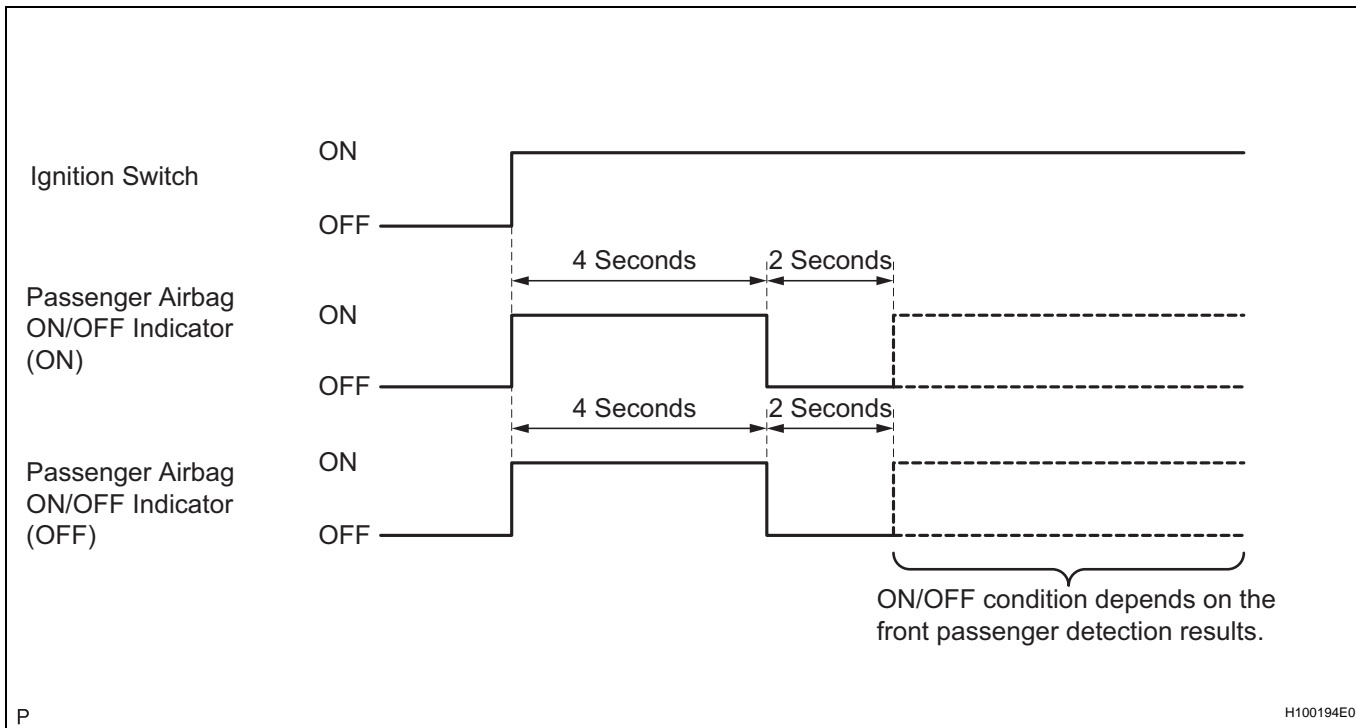

- When the occupant classification system malfunctions, the SRS warning light comes on and the passenger airbag ON/OFF indicator indicates OFF. In this case, check the DTCs in the airbag system first.

**4. PASSENGER AIRBAG ON/OFF INDICATOR CHECK**

- Turn the ignition switch to the ON position.
- Check that the passenger airbag ON/OFF indicator illuminates ON and OFF for approximately 4 seconds, and then turns them off for approximately 2 seconds.

**HINT:**

Refer to the table in the previous step regarding the passenger airbag ON/OFF indicator when approximately 6 seconds have elapsed after the ignition switch is turned to the ON position.

RS

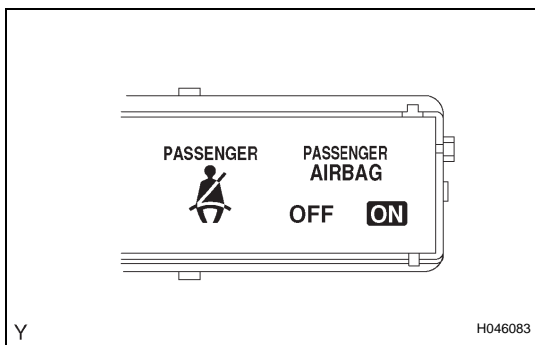

Y

H046083