

RADIO SETTING CONDENSER (for 1GR-FE)

COMPONENTS

AV

RADIO SETTING CONDENSER

ENGINE TYPE: 1GR-FE

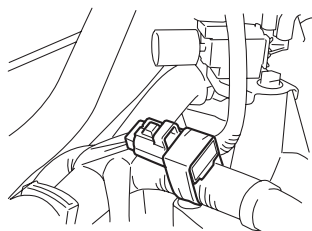

ENGINE TYPE: 2TR-FE

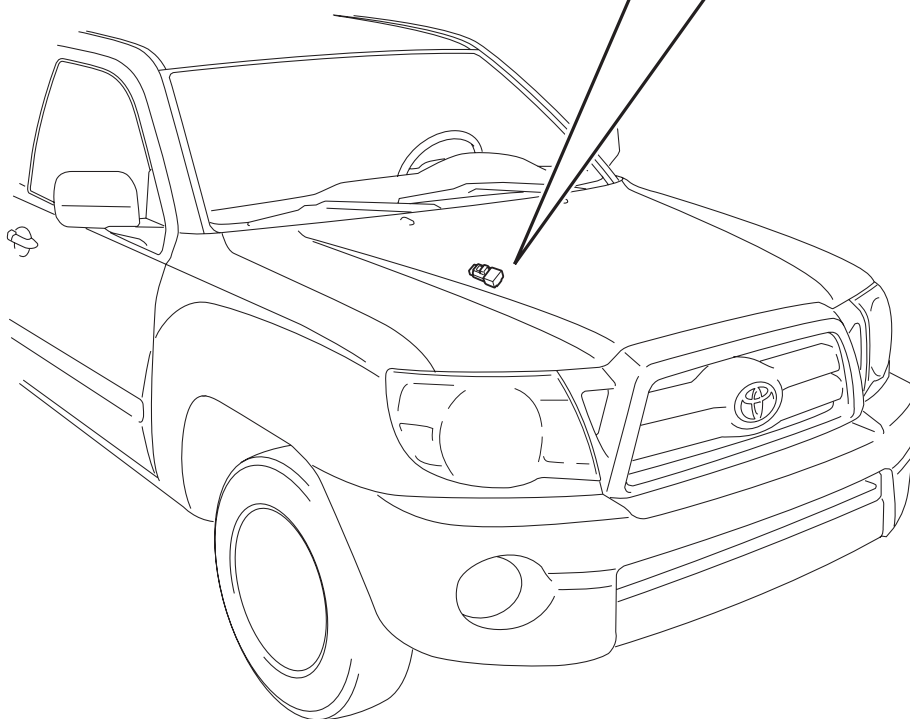
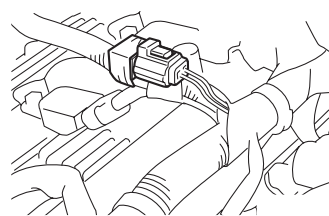

AV

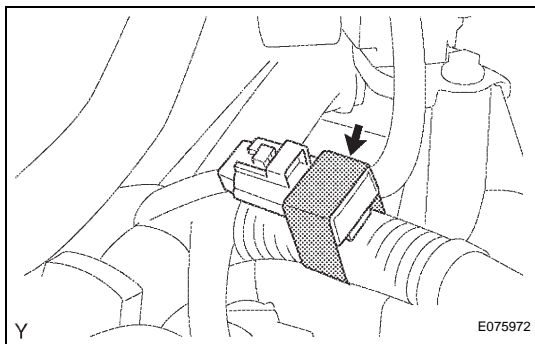
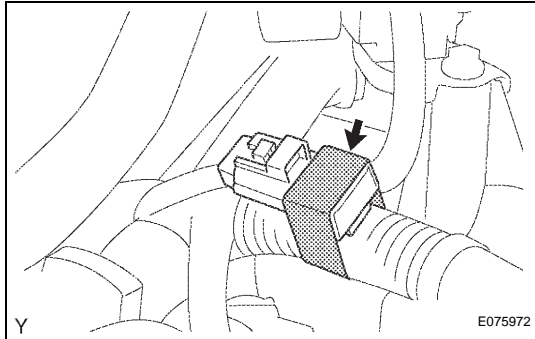

REMOVAL

1. **DISCONNECT CABLE FROM NEGATIVE BATTERY TERMINAL**
2. **REMOVE V-BANK COVER** (See page [ES-414](#))
3. **REMOVE AIR CLEANER ASSEMBLY** (See page [ES-415](#))
4. **REMOVE RADIO SETTING CONDENSER**
 - (a) Disconnect the connector.
 - (b) Remove the tape and the radio setting condenser.

INSTALLATION

1. **INSTALL RADIO SETTING CONDENSER**
 - (a) Disconnect the connector.
 - (b) Wind new vinyl tape around the hose and install the radio setting condenser.
2. **INSTALL AIR CLEANER ASSEMBLY** (See page [ES-416](#))
3. **INSTALL V-BANK COVER** (See page [ES-416](#))
4. **CONNECT CABLE TO NEGATIVE BATTERY TERMINAL**
Torque: 3.9 N*m (40 kgf*cm, 35 in.*lbf)