

BACK WINDOW GLASS

COMPONENTS

for Double Cab:

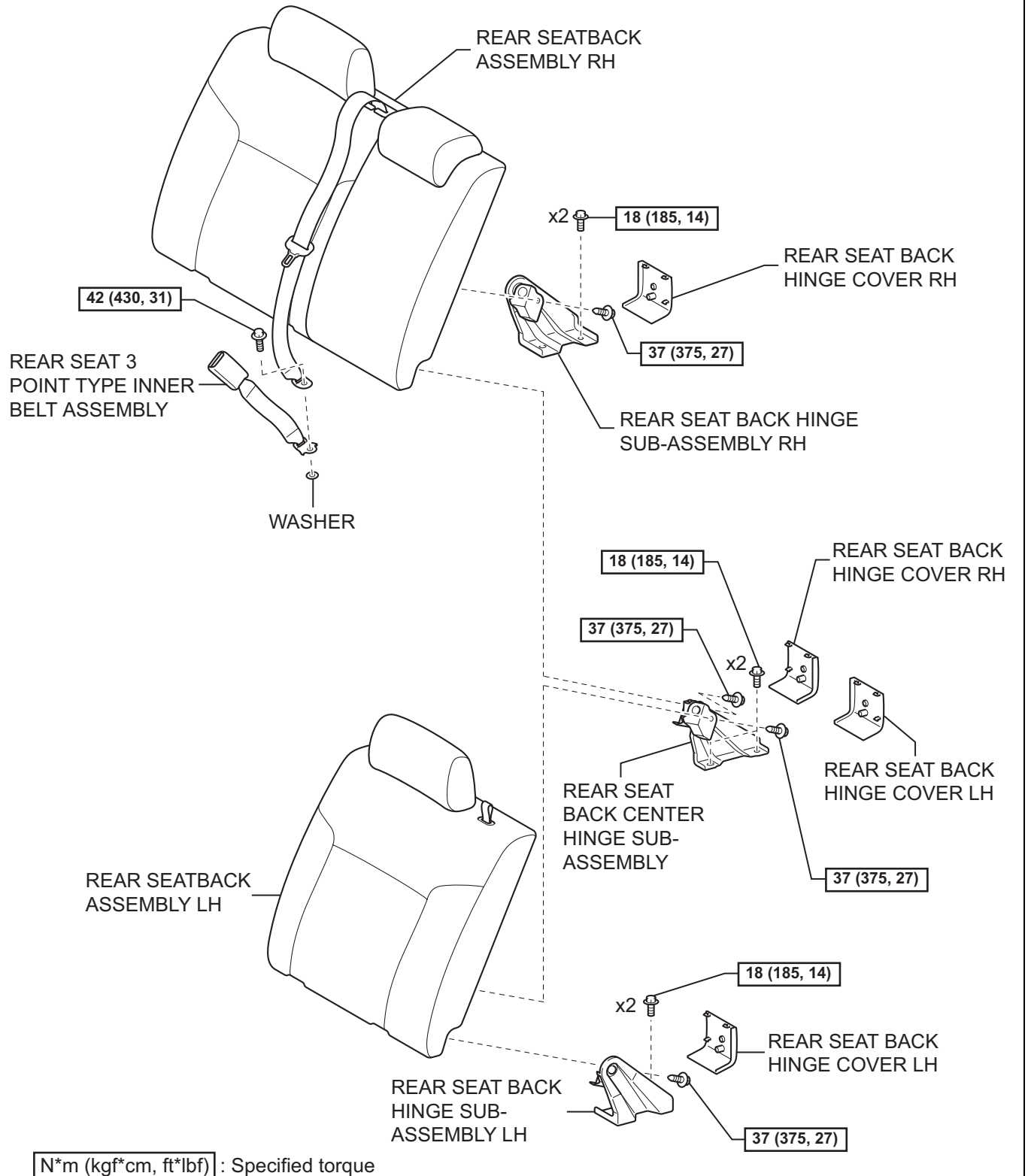

WS

for Regular Cab:

for Bench Seat Type:

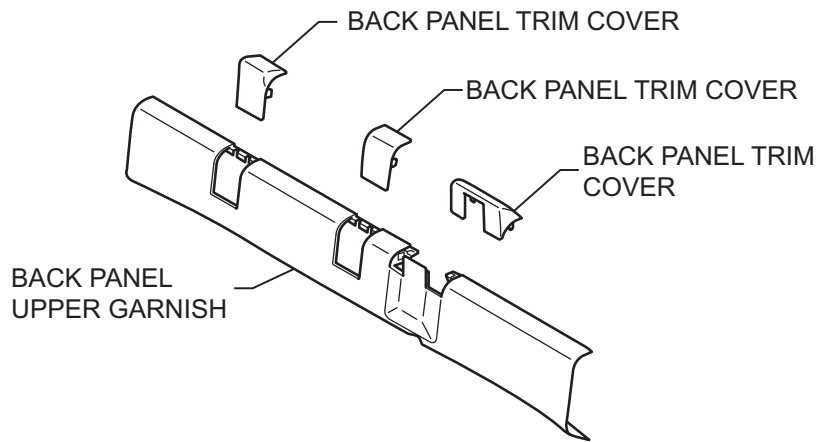

for Separate Seat Type:

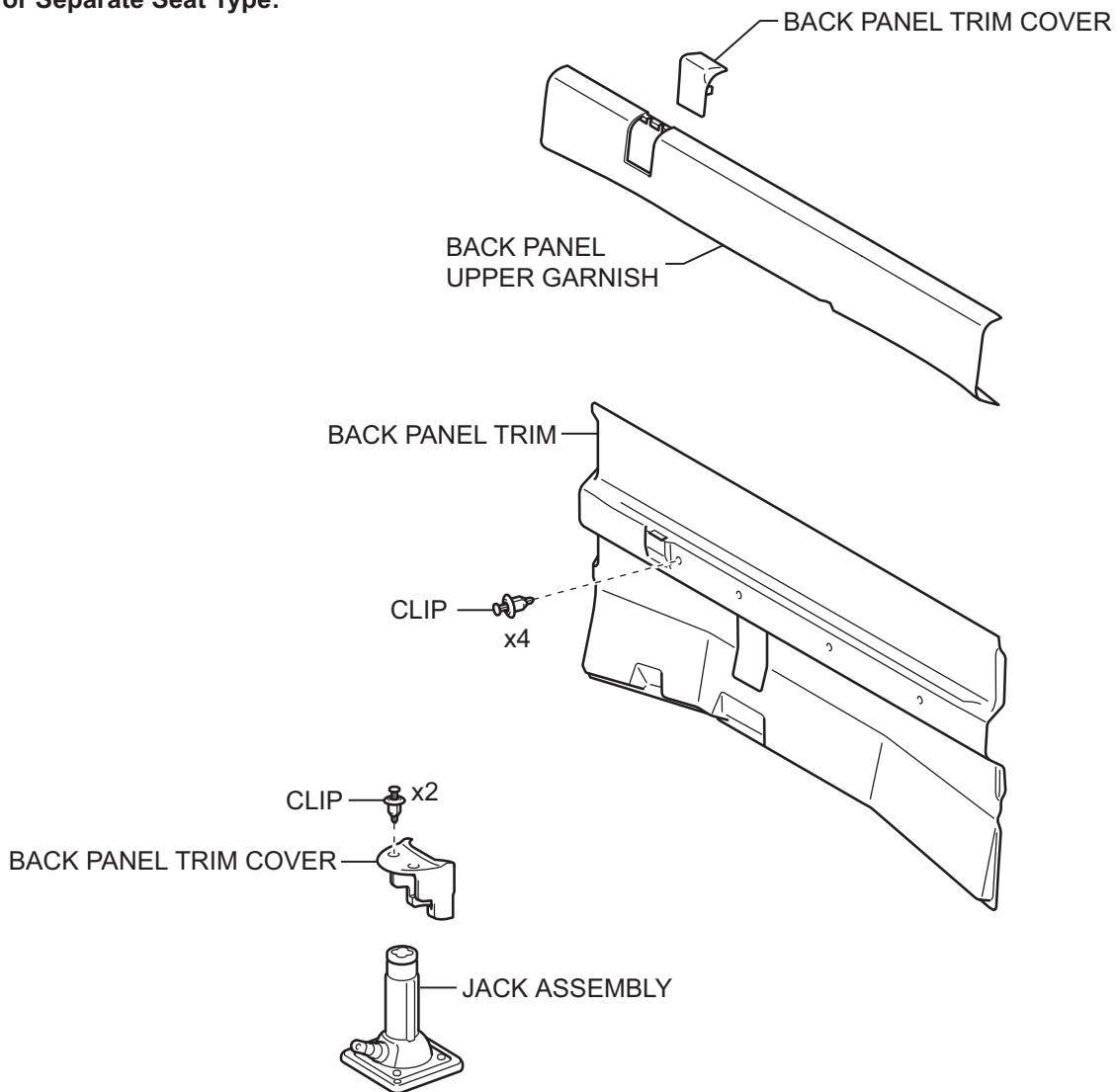

WS

for Access Cab:

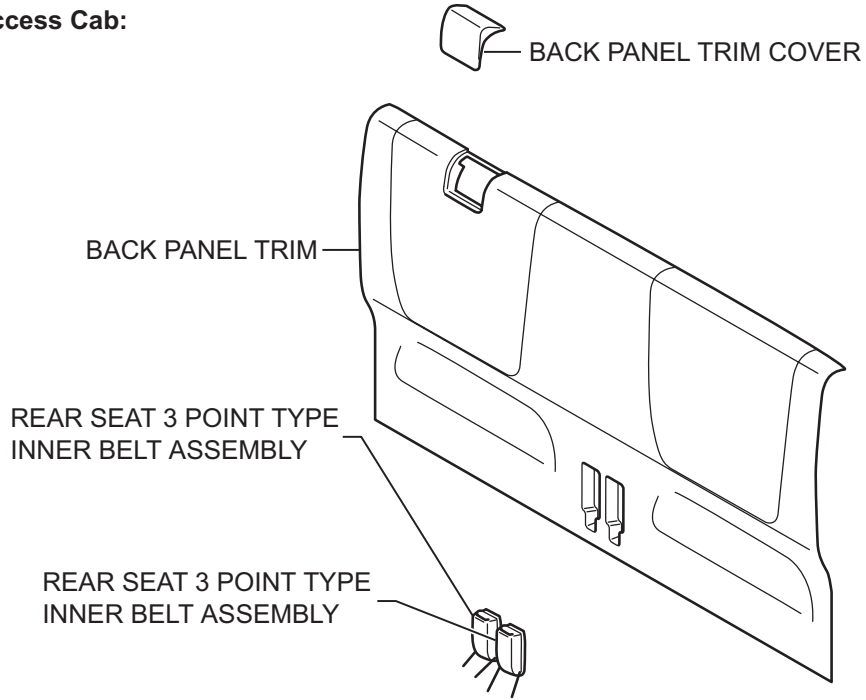

for Double Cab:

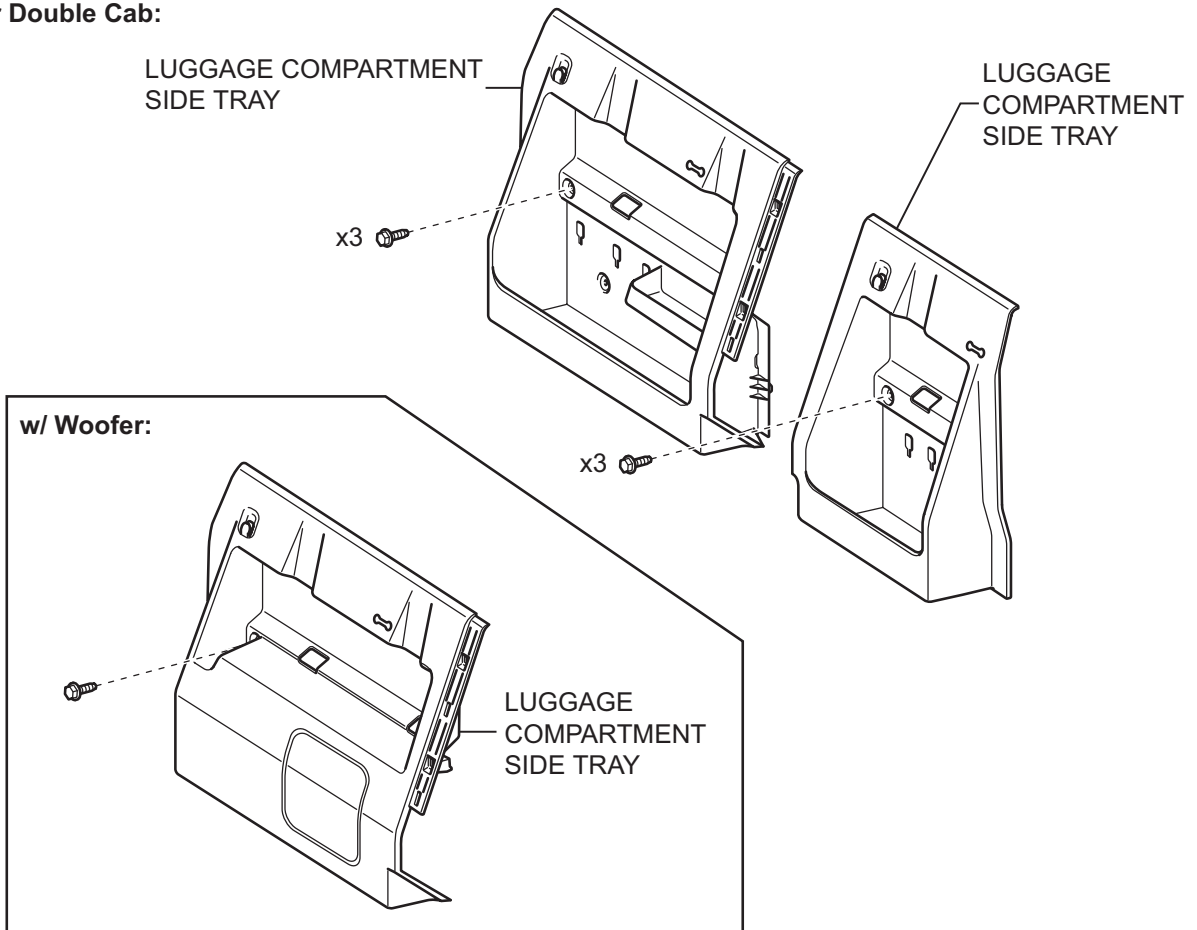

for Regular Cab:

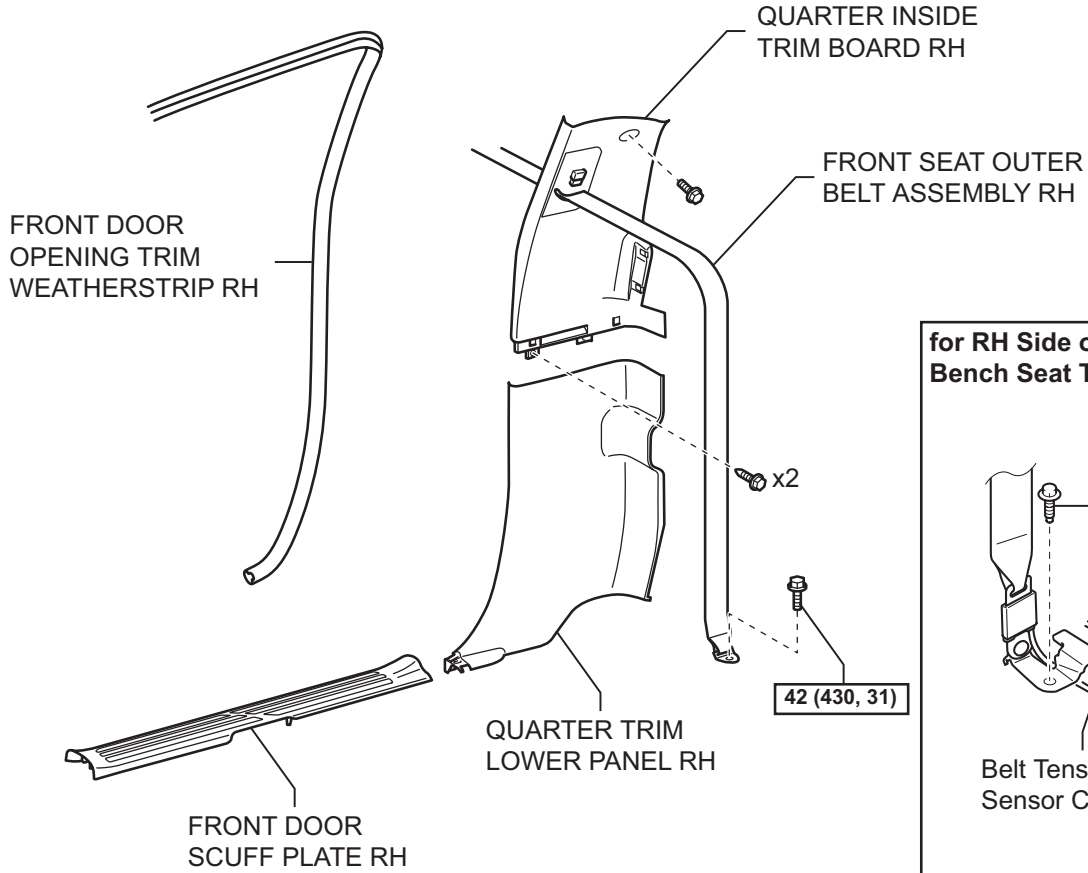

for RH Side on Bench Seat Type:

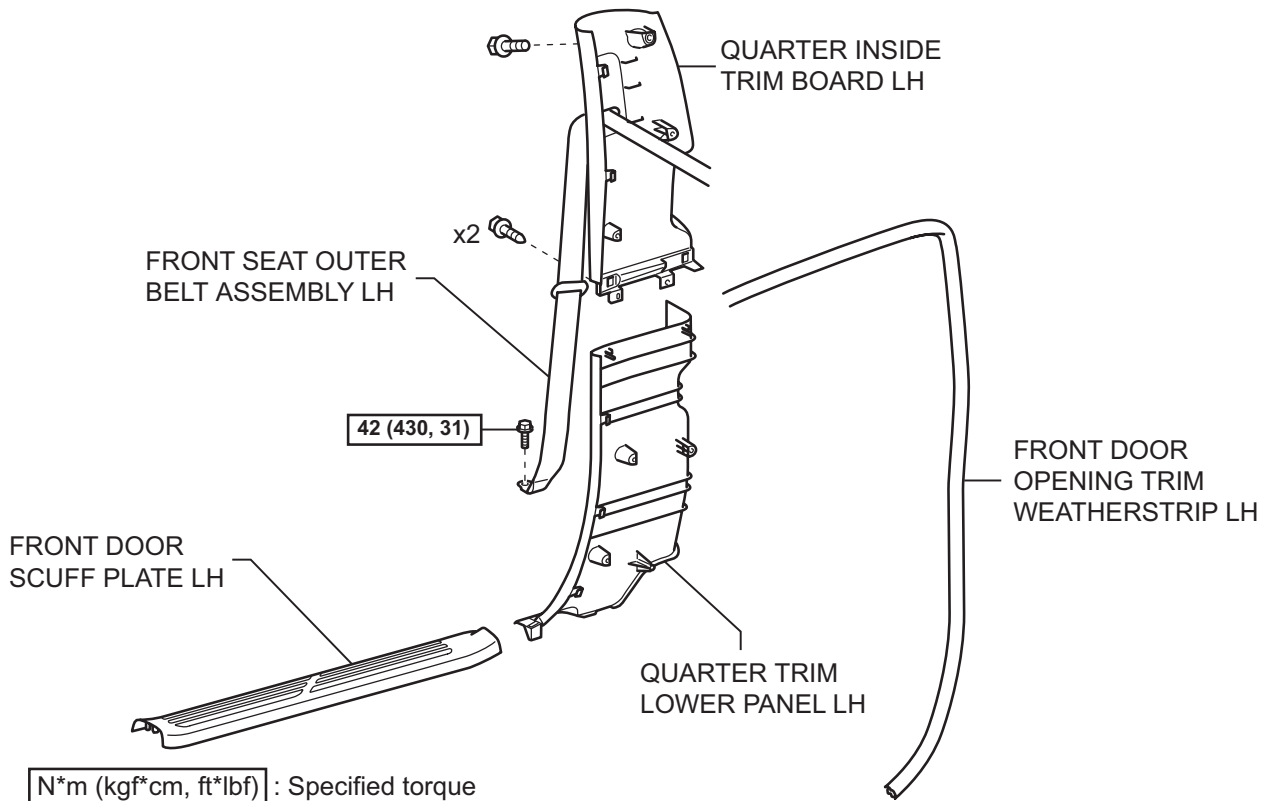
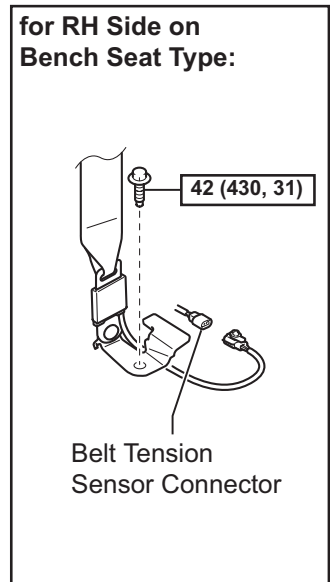

for Access Cab:

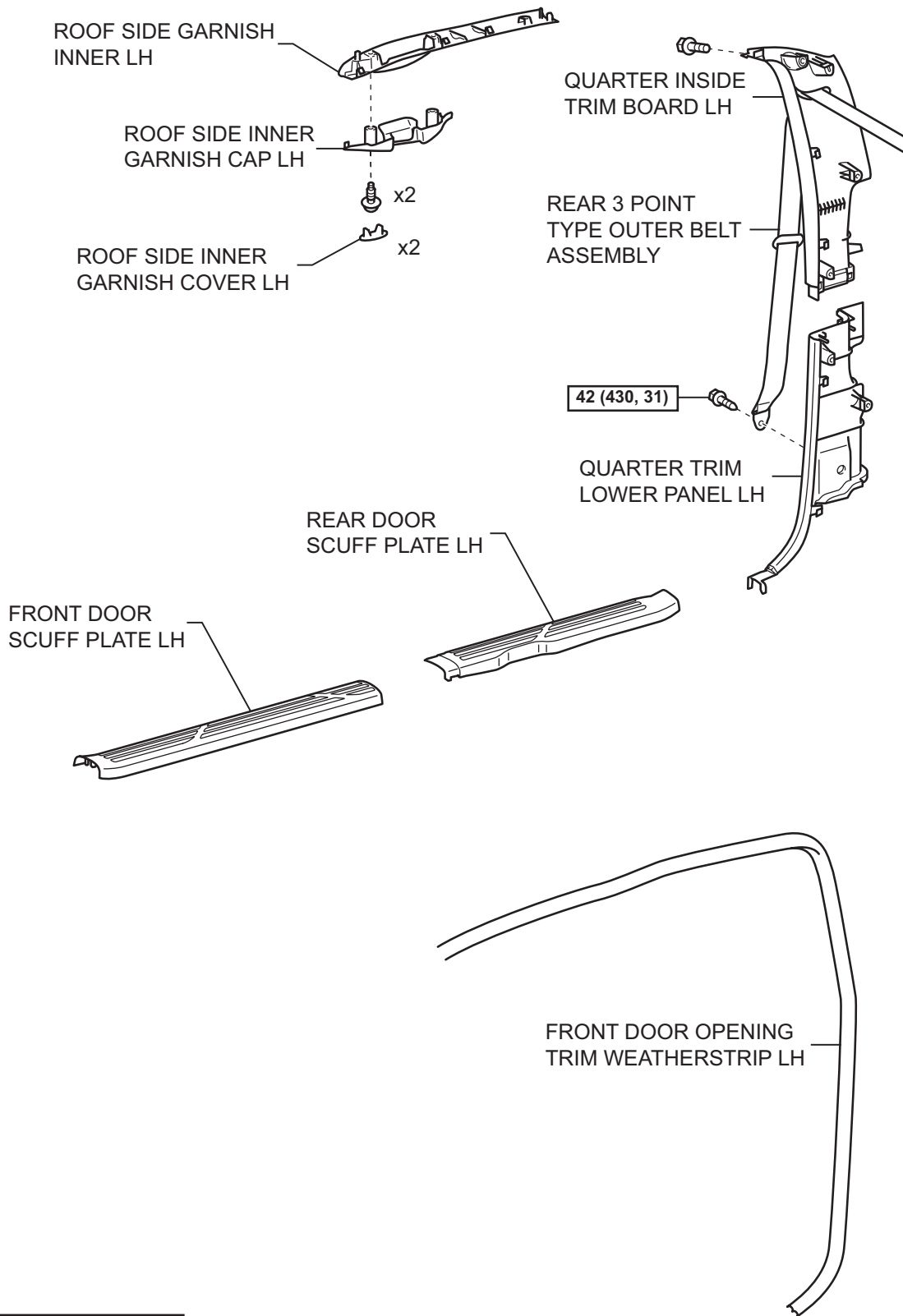

WS

N*m (kgf*cm, ft*lbf) : Specified torque

for Access Cab:

WS

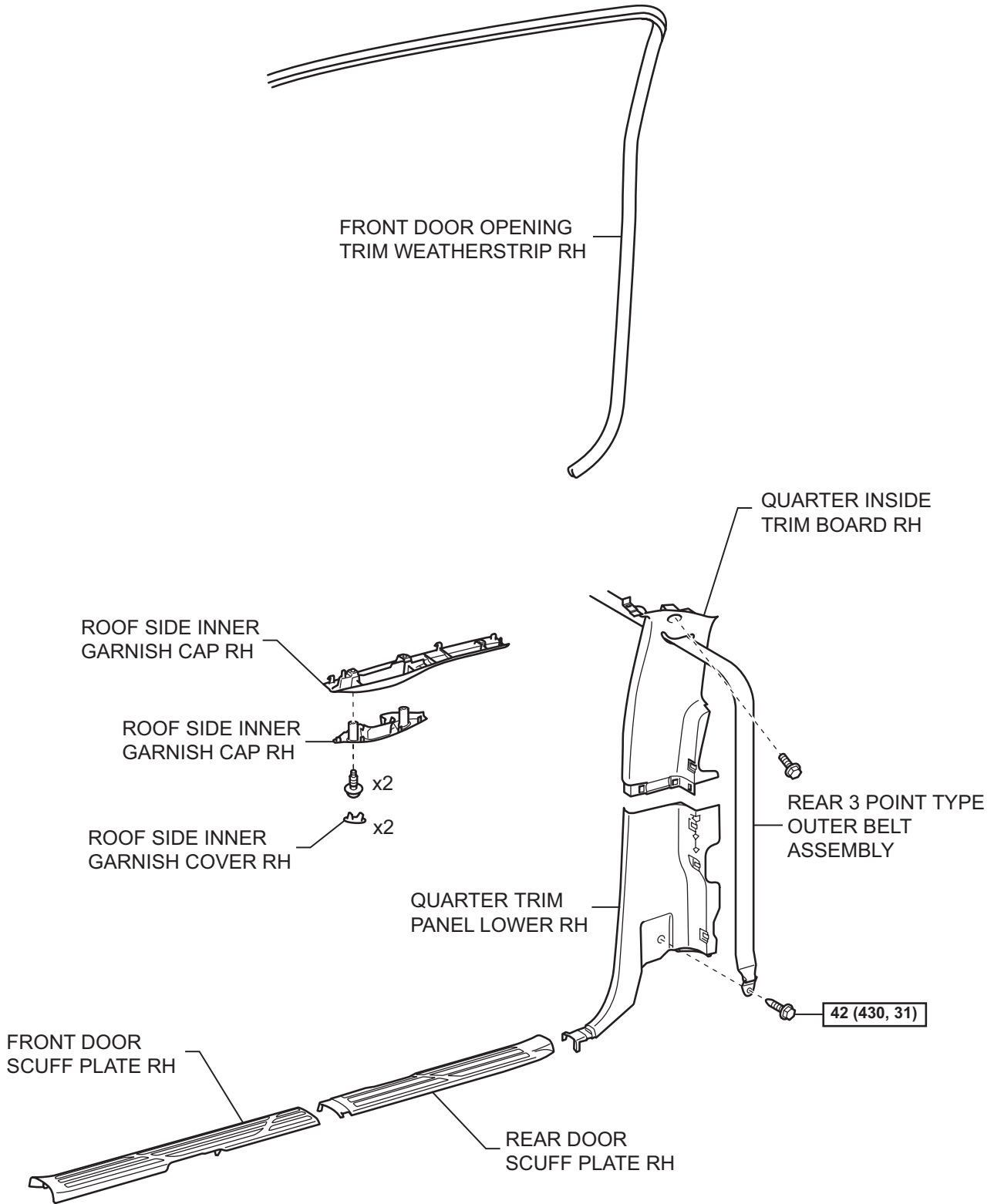

N*m (kgf*cm, ft*lbf) : Specified torque

for Double Cab:

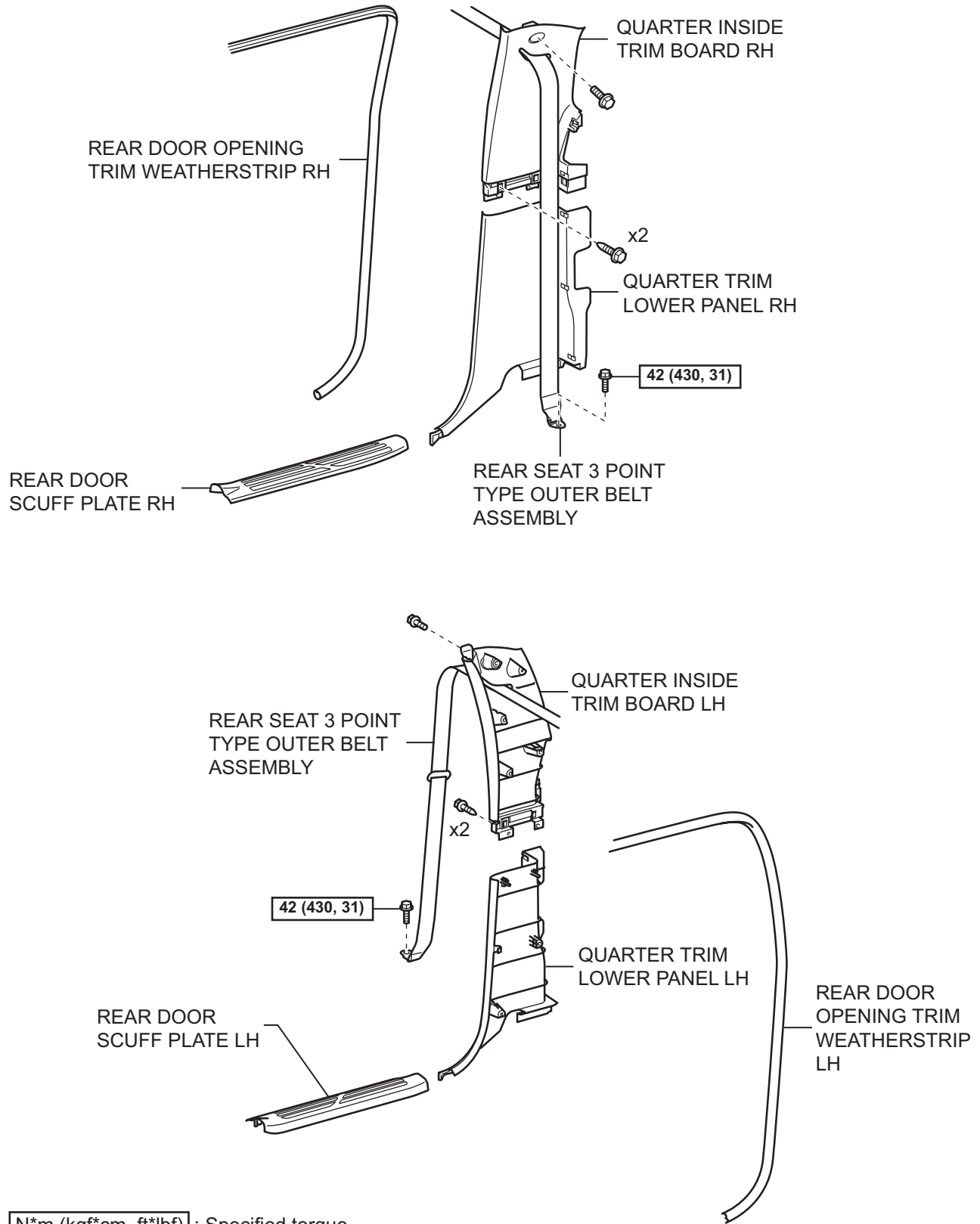

WS

WS

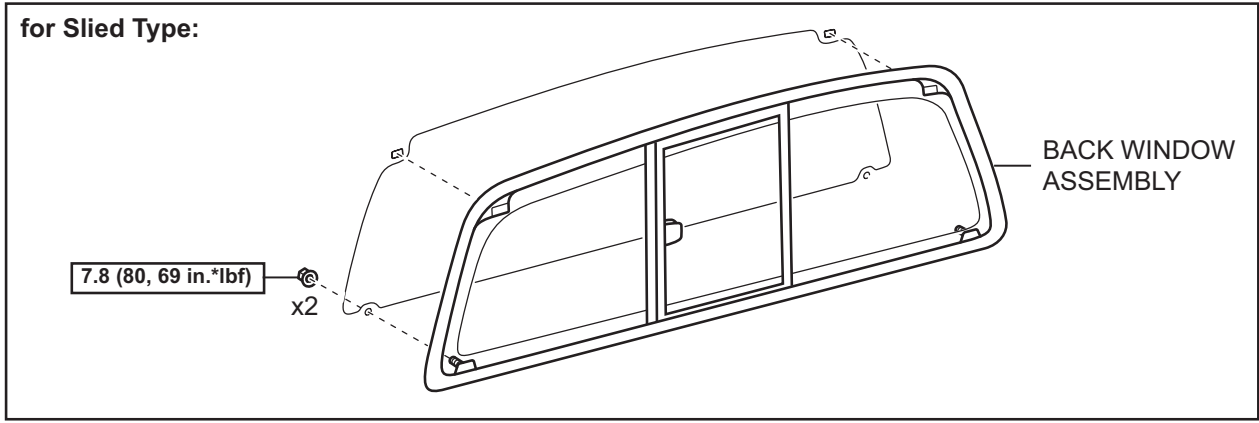
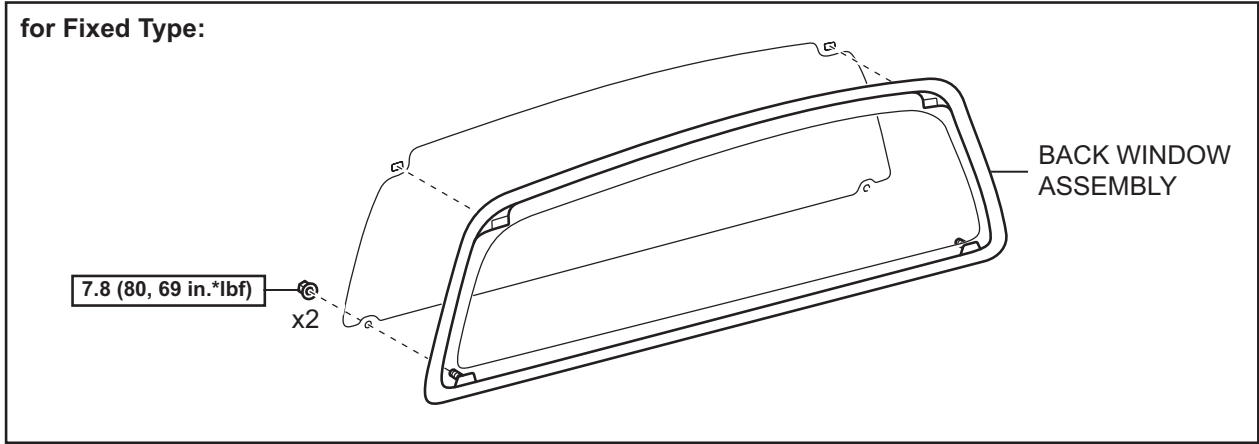
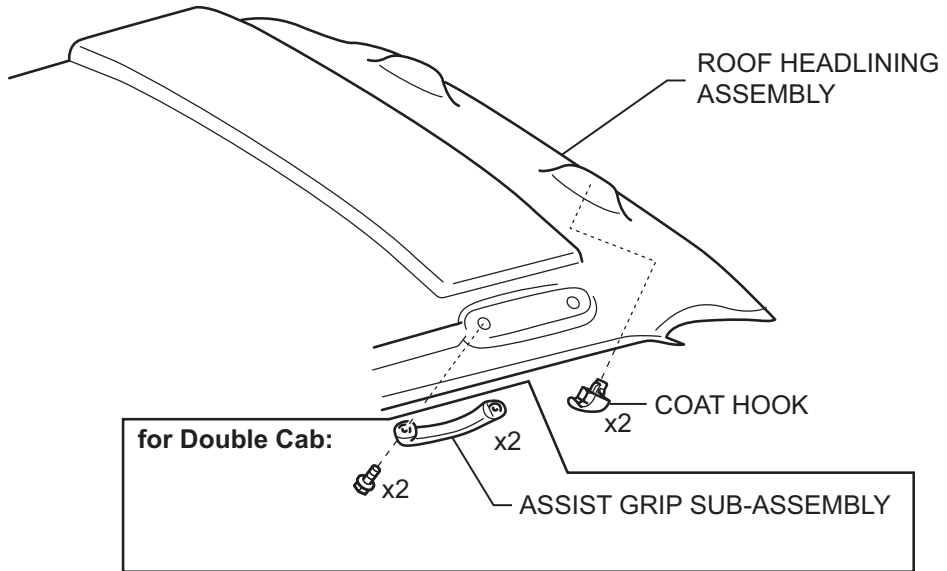

N*m (kgf*cm, ft*lbf) : Specified torque