

INSTALLATION

CAUTION:

Some of these service operations affect the SRS airbag system. Read the precautionary notices concerning the SRS airbag system before servicing (w/ Front Seat Side Airbag) (See page [RS-1](#)).

1. INSTALL FRONT SEAT ASSEMBLY

- (a) Place the front seat in the cabin.
- (b) Tighten the 2 bolts on the front side of the front seat.
Torque: 37 N*m (375 kgf*cm, 27 ft.*lbf)
- (c) Tighten the 2 bolts on the rear side of the front seat.
Torque: 37 N*m (375 kgf*cm, 27 ft.*lbf)

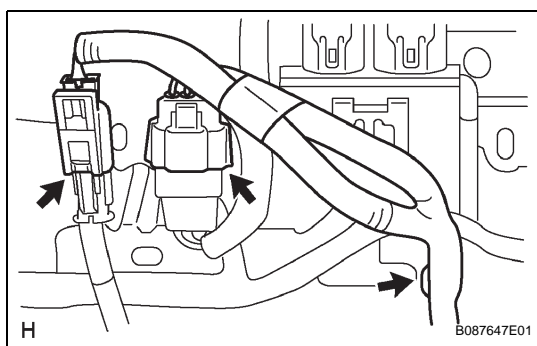

- (d) Install the wire harness clamp.
- (e) Connect the connector.
- (f) w/ Front Seat Side Airbag:
 - (1) Connect the connector.

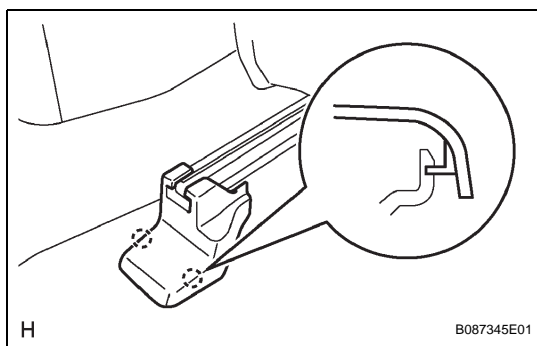

2. INSTALL SEAT TRACK COVER

HINT:

Follow the same procedures as for the opposite side.

- (a) Engage the 2 claws and install the seat track cover.

3. CONNECT CABLE TO NEGATIVE BATTERY TERMINAL

Torque: 3.9 N*m (40 kgf*cm, 35 in.*lbf)

4. INSPECT SRS WARNING LIGHT (w/ Front Seat Side Airbag)

(See page [RS-28](#))