

# FRONT SEAT ASSEMBLY (for Bench Seat Type)

## COMPONENTS

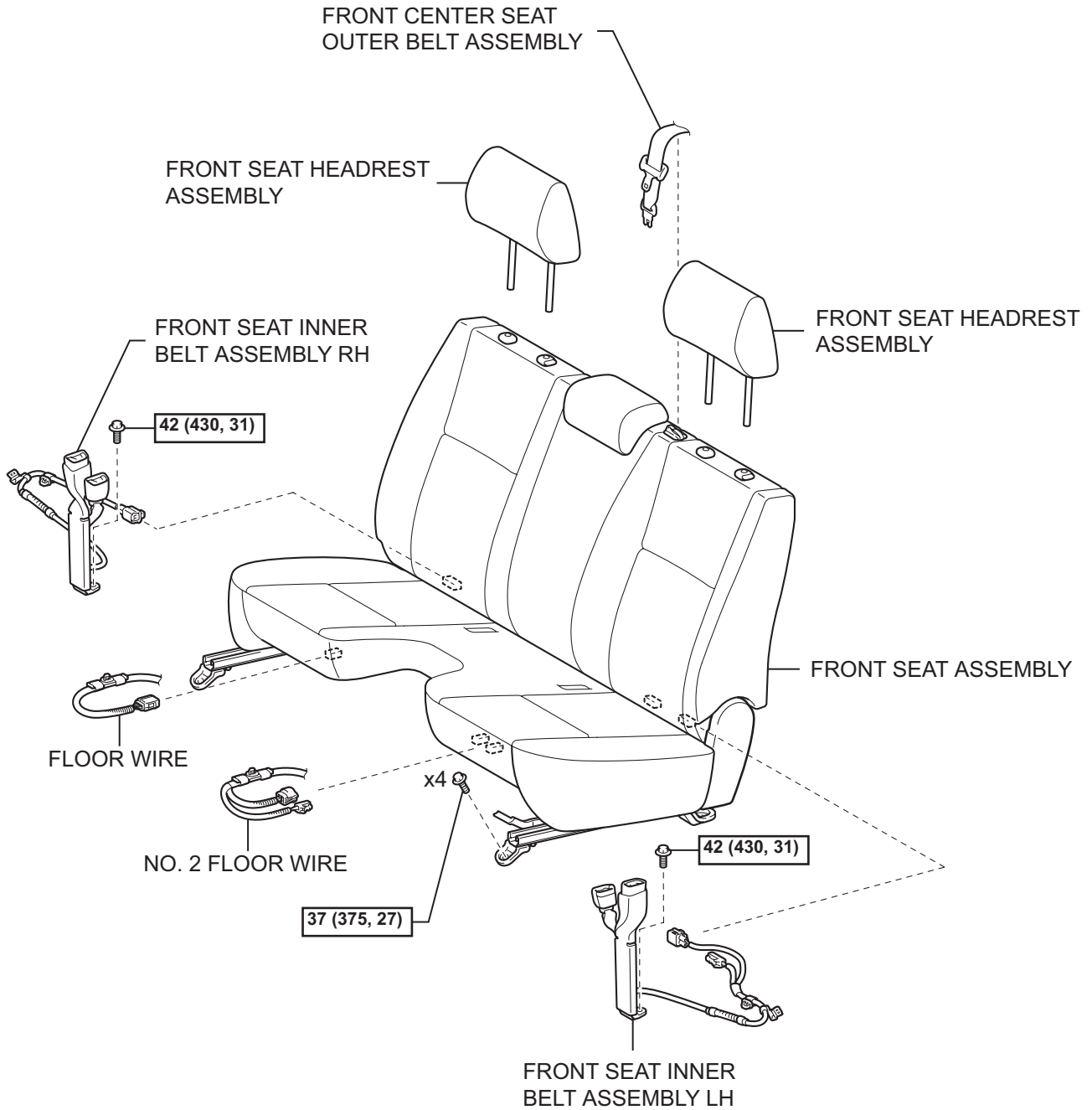

**N\*m (kgf\*cm, ft\*lbf)** : Specified torque

SE

SE

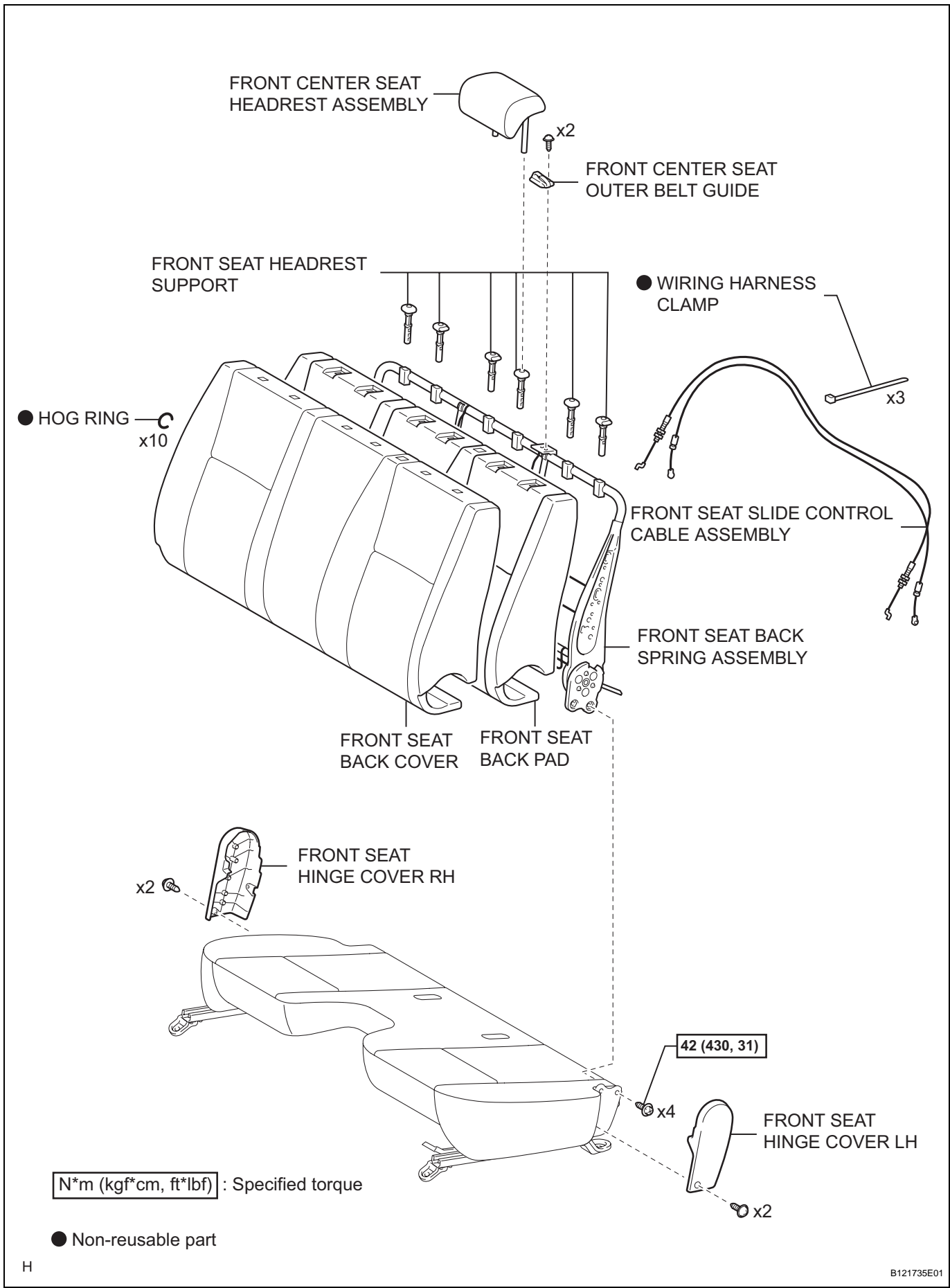

SE

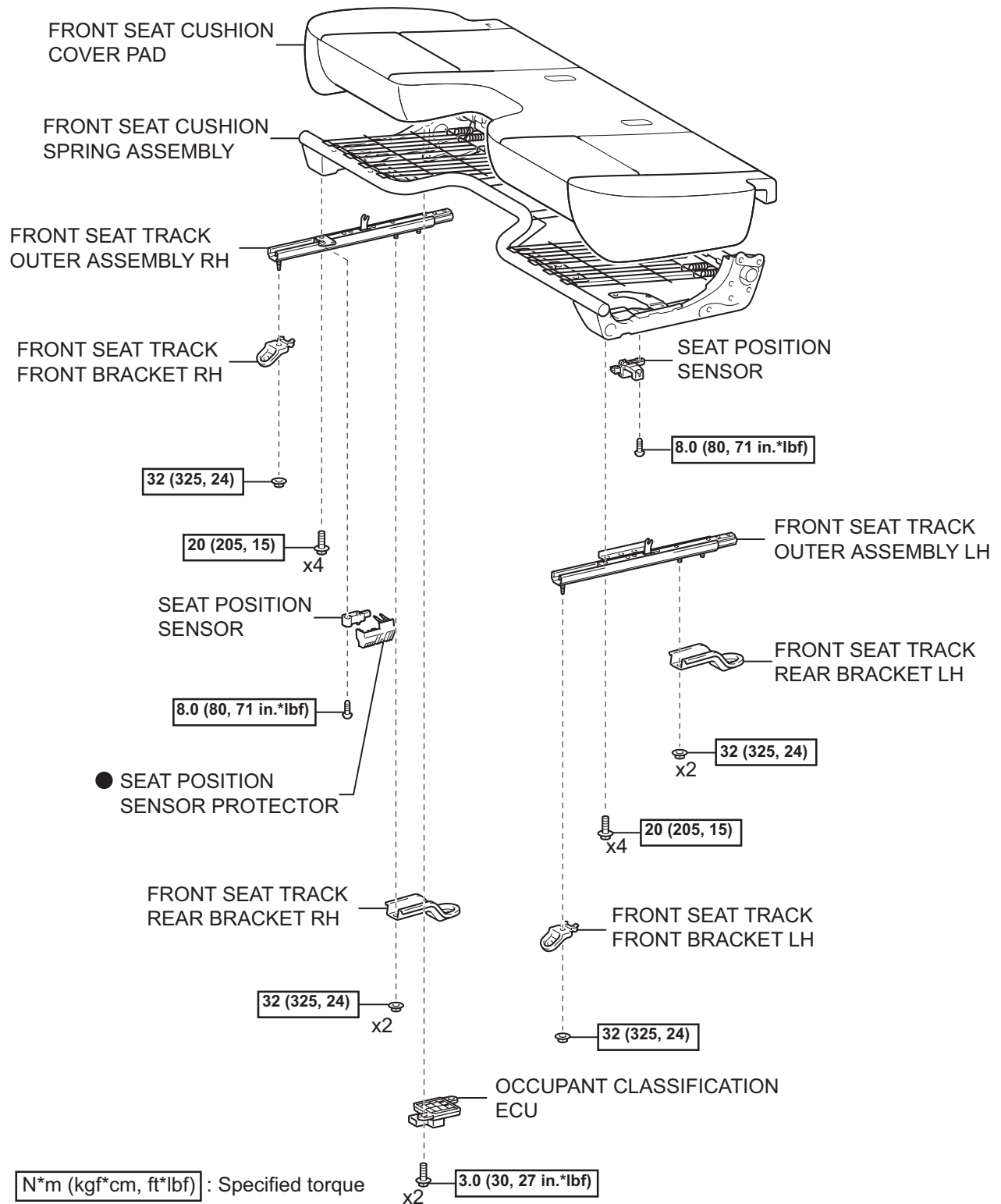

SE

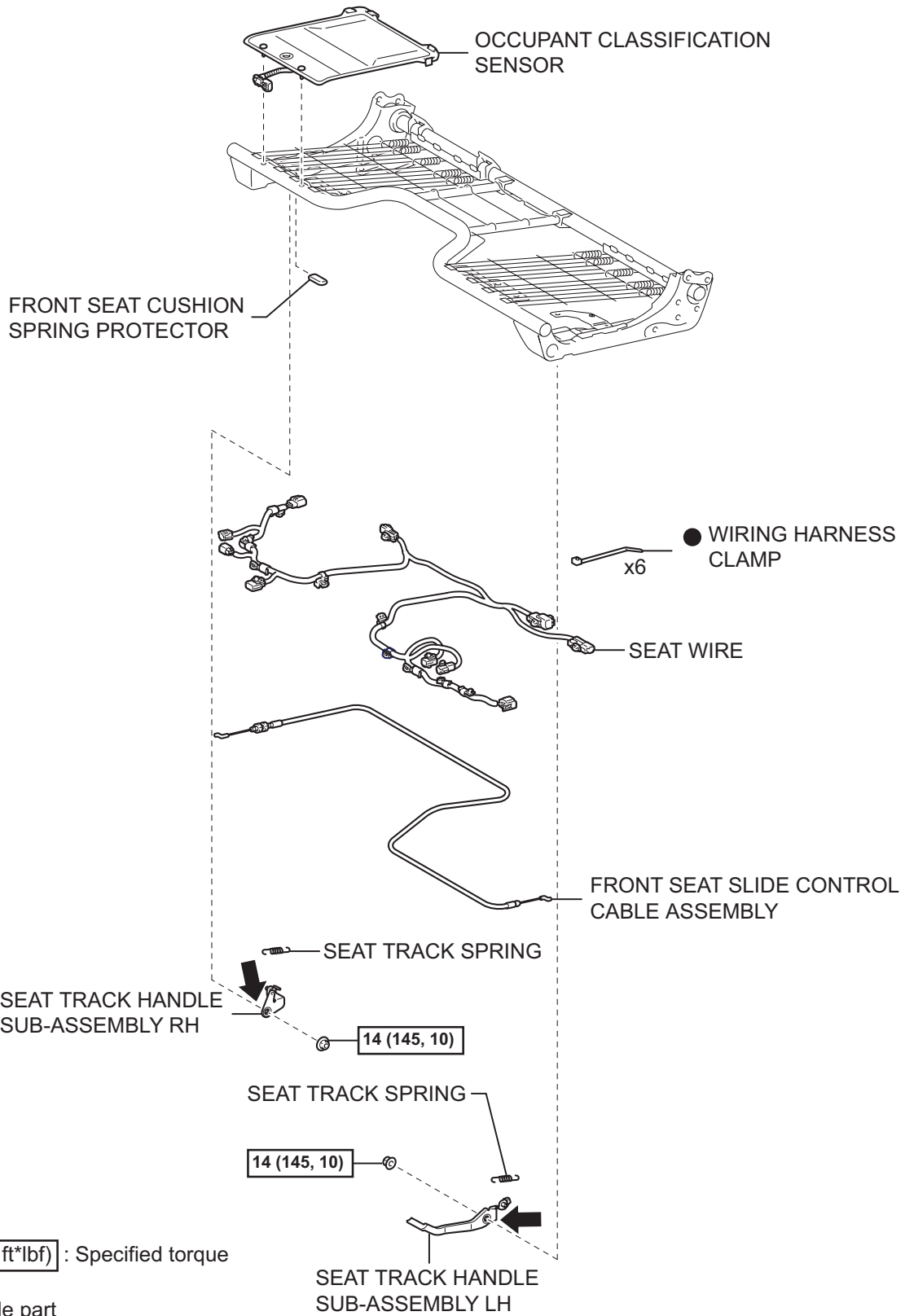

**N\*m (kgf\*cm, ft\*lbf)** : Specified torque

● Non-reusable part

← Apply Grease

H