

ADJUSTMENT

HINT:

- Before adjusting the positions of doors on vehicles equipped with side airbags and curtain shield airbags, be sure to disconnect the cable from the negative battery terminal. After making adjustments, inspect the SRS warning lamp, the side airbag system and the curtain shield airbag system for normal operation (See page [RS-28](#)).
- Use the same procedure for both the RH and LH sides.
- The procedures listed below are for the LH side.
- Centering bolts are used to mount the door hinge onto the vehicle body and door. The doors cannot be adjusted with the centering bolts on. Substitute the standard bolts (with washers) for the centering bolts when making adjustments.
- For bolts without torque specifications, check the standard bolt chart (See page [SS-2](#)).

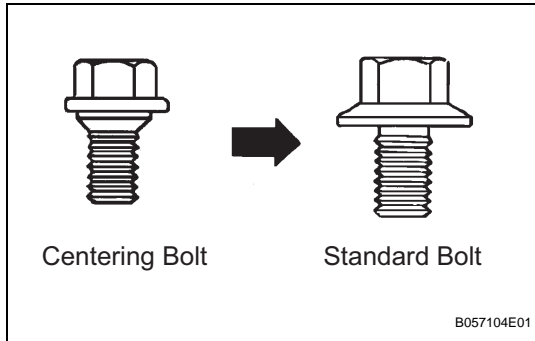

1. **INSPECT REAR DOOR PANEL SUB-ASSEMBLY LH**
 - (a) Check that the clearance measurements of areas A to F are within the standard ranges.

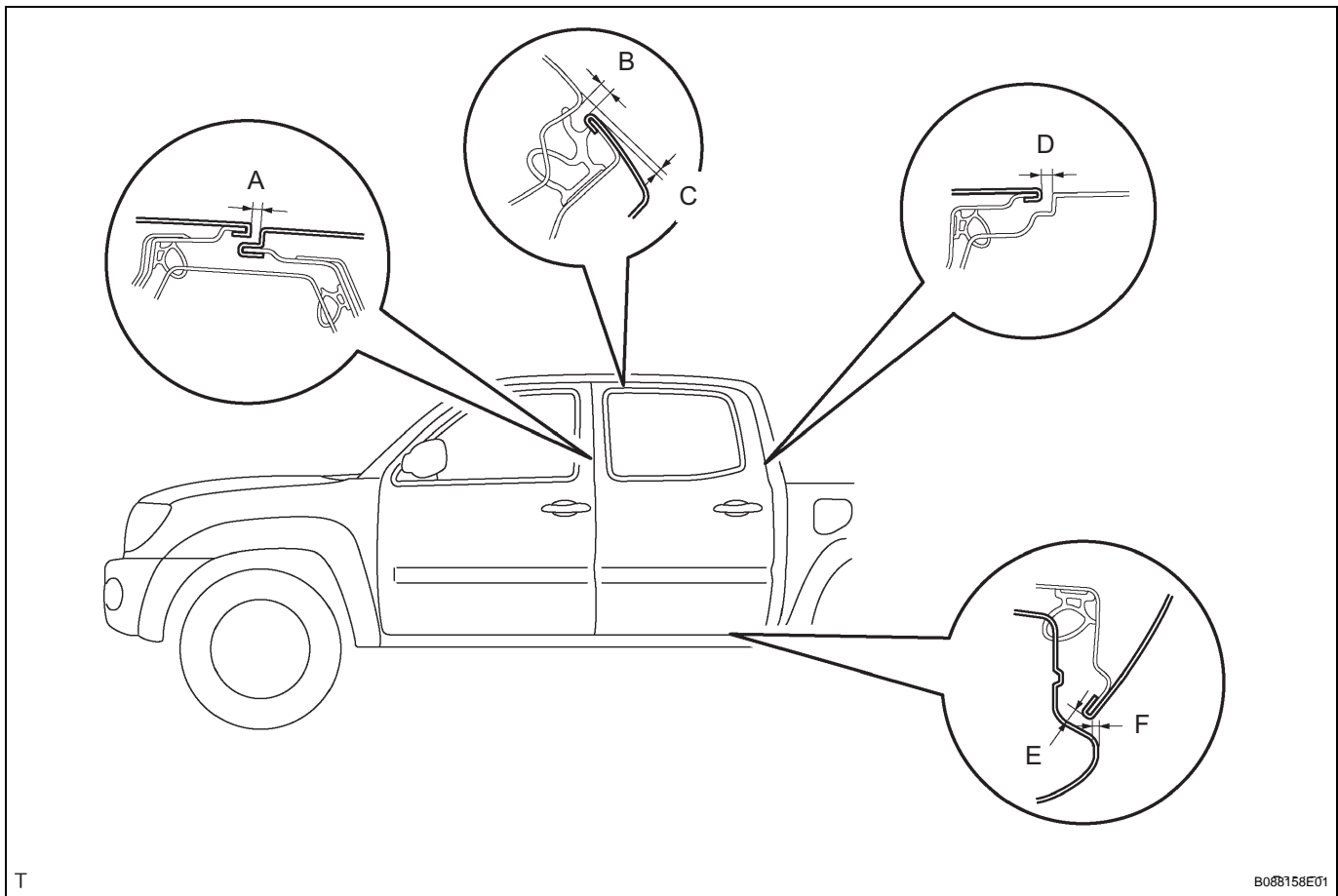

Standard:

Area	Measurement	Area	Measurement
A	5.0 +- 1.5 mm (0.197 +- 0.059 in.)	D	4.5 +- 1.5 mm (0.177 +- 0.059 in.)
B	5.0 +- 1.5 mm (0.197 +- 0.059 in.)	E	5.0 +- 1.5 mm (0.197 +- 0.059 in.)
C	1.8 +- 1.5 mm (0.071 +- 0.059 in.)	F	2.0 +- 1.5 mm (0.079 +- 0.059 in.)

2. ADJUST REAR DOOR PANEL SUB-ASSEMBLY LH

- (a) Disconnect the cable from the negative battery terminal.

CAUTION:

Work must be started at least 90 seconds after the ignition switch is turned to OFF and the cable is disconnected from the negative battery terminal. (The SRS is equipped with a back-up power source. If work is started within 90 seconds of disconnecting the cable from the negative battery terminal and the ignition switch being turned to OFF, the SRS may deploy.)

- (b) Using SST, adjust the door horizontally and vertically by loosening the body side hinge bolts.

SST 09812-00010

- (c) Tighten the body side hinge bolts after the adjustment.

Torque: 26 N*m (265 kgf*cm, 19 ft.*lbf)

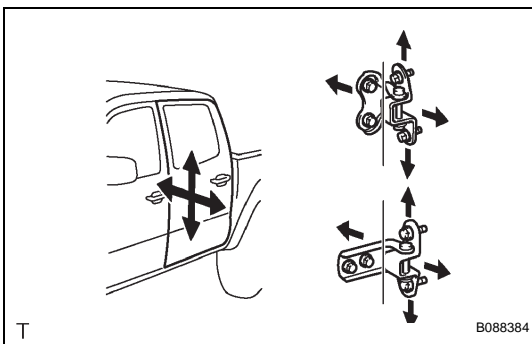
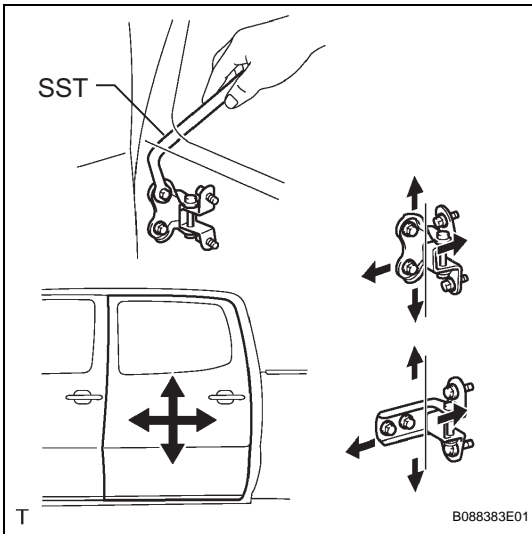

- (d) Loosen the door side hinge bolts and adjust the door position.

- (e) Tighten the door side hinge bolts after the adjustment.

Torque: 26 N*m (265 kgf*cm, 19 ft.*lbf)

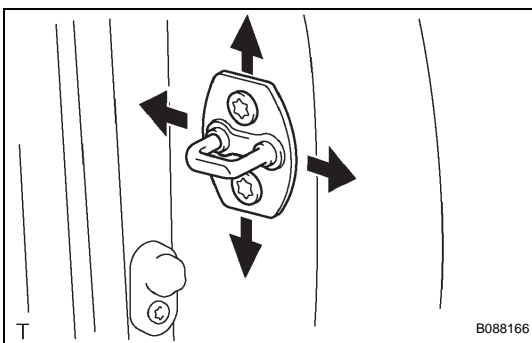

- (f) Adjust the striker position by slightly loosening the striker mounting screws using a torx socket wrench T40 and hitting the striker with a plastic hammer.

- (g) Using a torx socket wrench T40, tighten the striker mounting screws after the adjustment.

Torque: 23 N*m (235 kgf*cm, 17 ft.*lbf)

- (h) Connect the cable to the negative battery terminal.

Torque: 3.9 N*m (40 kgf*cm, 35 in.*lbf)

- (i) Inspect the SRS warning lamp (See page [RS-28](#)).