

WHEEL OPENING MOULDING

REMOVAL

1. REMOVE FRONT FENDER MUDGUARD (for 4WD and Pre-Runner) (See page [ET-45](#))
2. REMOVE ROCKER PANEL MOULDING (for X-Runner) (See page [ET-38](#))
3. REMOVE FRONT FENDER WHEEL OPENING MOULDING

- (a) for 4WD and Pre Runner:
 - (1) Remove the 4 screws.

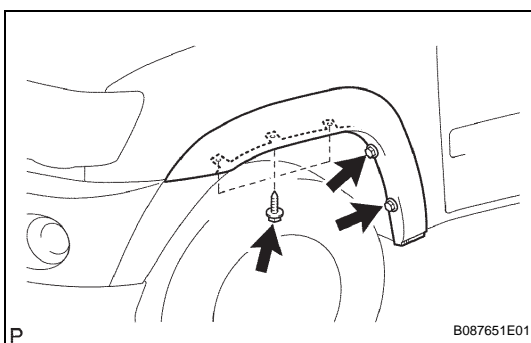
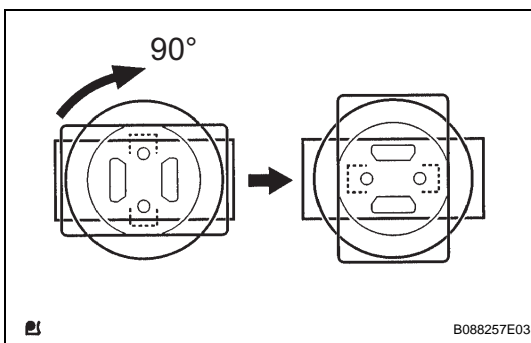
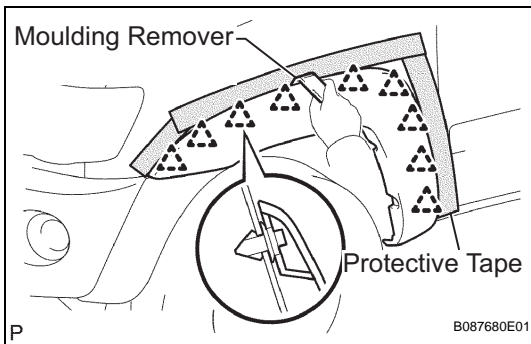
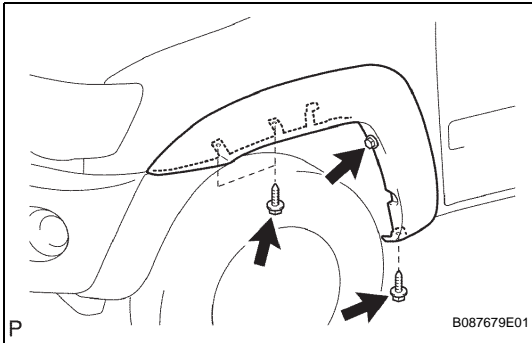

- (2) Apply protective tape to the outer circumference of the front fender wheel opening moulding, as shown in the illustration.
- (3) Using a moulding remover, disengage the 9 clips and remove the front fender wheel opening moulding.

- (4) Turn the clips 90° clockwise and remove them.

- (b) for X-Runner:
 - (1) Remove the 5 screws and front fender wheel opening moulding.

4. REMOVE REAR QUARTER PANEL MUDGUARD (for 4WD and Pre-Runner) (See page [ET-45](#))
5. REMOVE BACK DOOR OUTSIDE MOULDING SUB-ASSEMBLY (for X-Runner) (See page [ET-39](#))
6. REMOVE BODY ROCKER PANEL MOULDING ASSEMBLY (for X-Runner) (See page [ET-38](#))

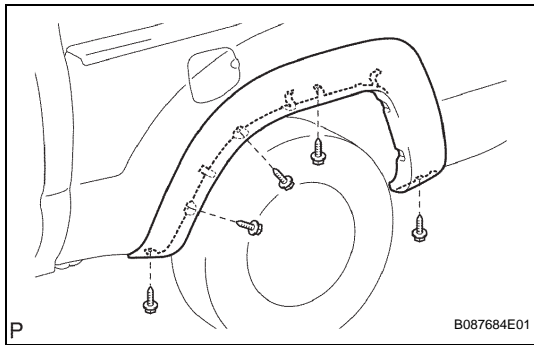

7. REMOVE QUARTER PANEL WHEEL OPENING MOULDING

- (a) for 4WD and Pre Runner:
 (1) Remove the 5 screws.

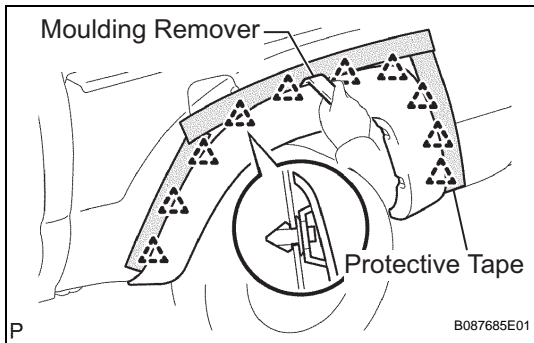

- (2) Apply protective tape to the outer circumference of the quarter panel wheel opening moulding, as shown in the illustration.
 (3) Using a moulding remover, disengage the 10 clips and remove the quarter panel wheel opening moulding.

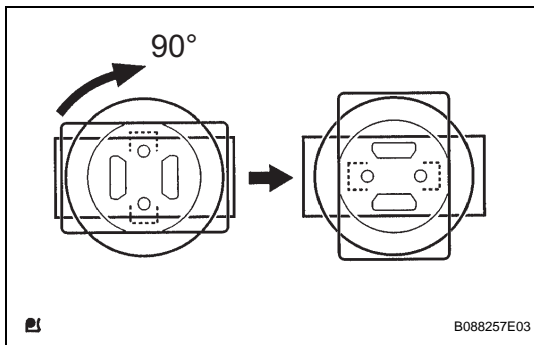

- (4) Turn the clips 90° clockwise and remove them.

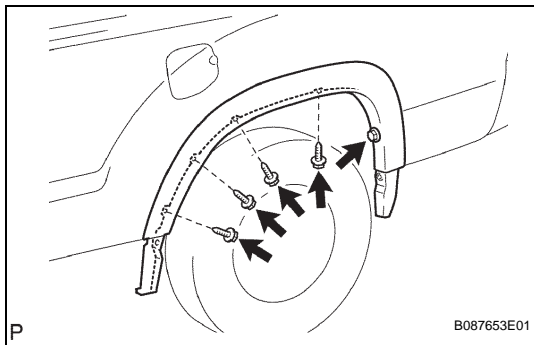

- (b) for X-Runner:
 (1) Remove the 5 screws and quarter panel wheel opening moulding.

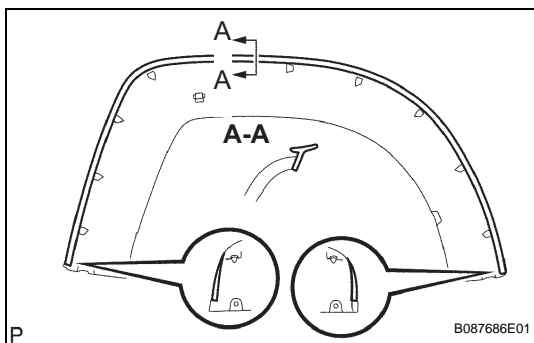

INSTALLATION

1. INSTALL QUARTER PANEL WHEEL OPENING MOULDING

- (a) for 4WD and Pre Runner:
 (1) Install new No. 1 quarter panel moulding pad in the position shown in the illustration.

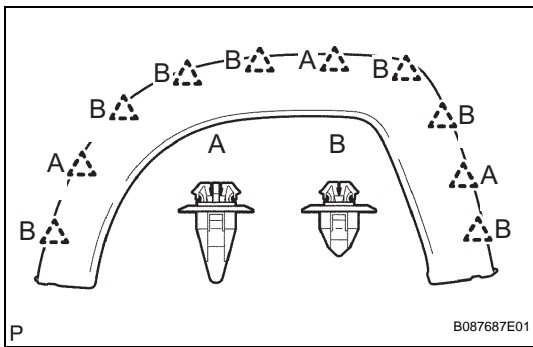

- (2) Install each clip in the position shown in the illustration.

NOTICE:

If you install the clips wrongly, the installation of the quarter panel wheel opening moulding would be improper.

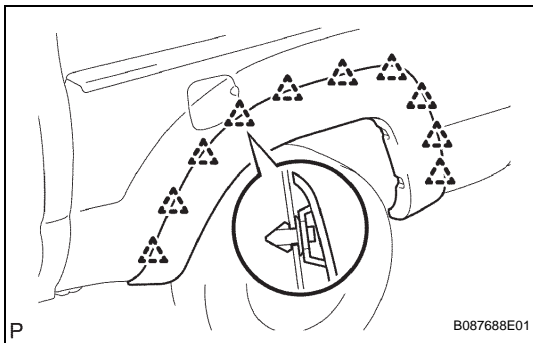

- (3) Engage the 10 clips and install the quarter panel wheel opening moulding.

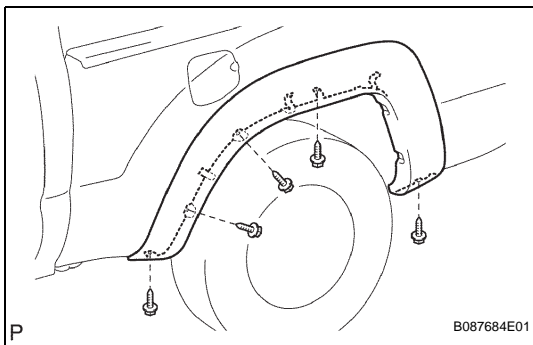

- (4) Tighten the 5 screws.

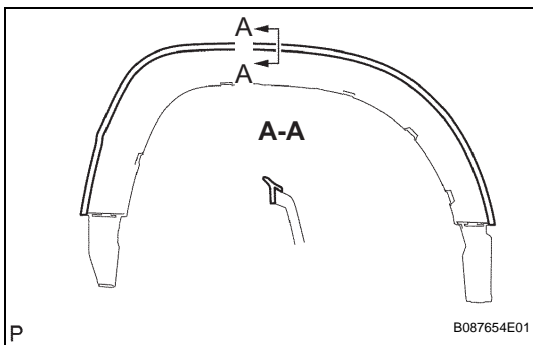

- (b) for X-Runner:

- (1) Install new No. 1 quarter panel moulding pad in the position shown in the illustration.

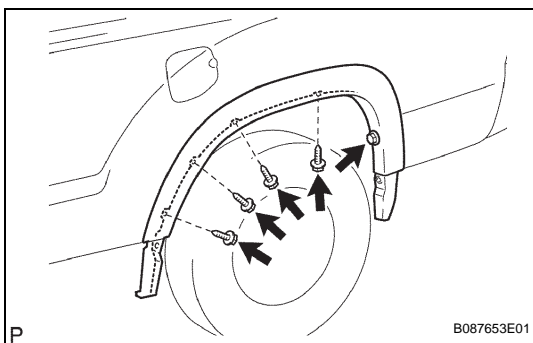

- (2) Install the quarter panel wheel opening moulding with the 5 screws.

2. **INSTALL BODY ROCKER PANEL MOULDING ASSEMBLY (for X-Runner) (See page ET-40)**
3. **INSTALL BACK DOOR OUTSIDE MOULDING SUB-ASSEMBLY (for X-Runner) (See page ET-39)**
4. **INSTALL REAR QUARTER PANEL MUDGUARD (for 4WD and Pre-Runner) (See page ET-45)**

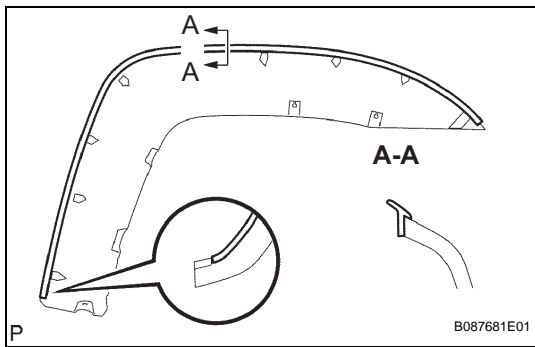

5. INSTALL FRONT FENDER WHEEL OPENING MOULDING

(a) for 4WD and Pre Runner:

- (1) Install new No. 1 front fender wheel opening extension pad in the position shown in the illustration.

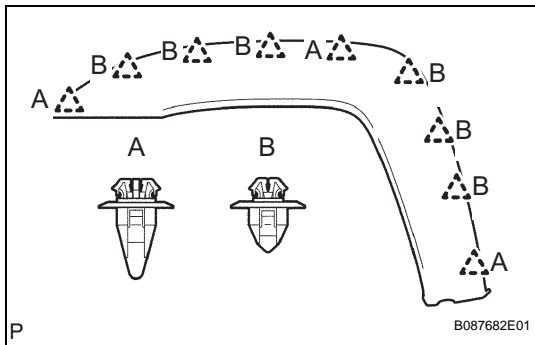

- (2) Install each clip in the position shown in the illustration.

NOTICE:
If you install the clip wrongly, the installation of the front fender wheel opening moulding would be improper.

- (3) Engage the 9 clips and install the front fender wheel opening moulding.

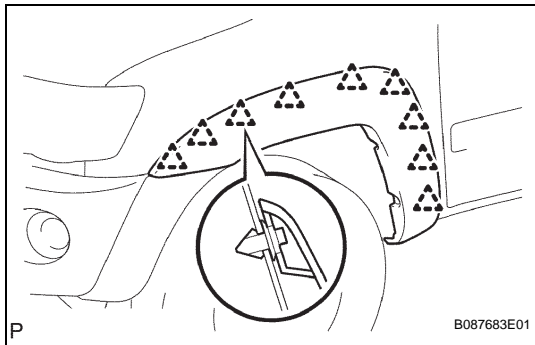

- (4) Tighten the 4 screws.

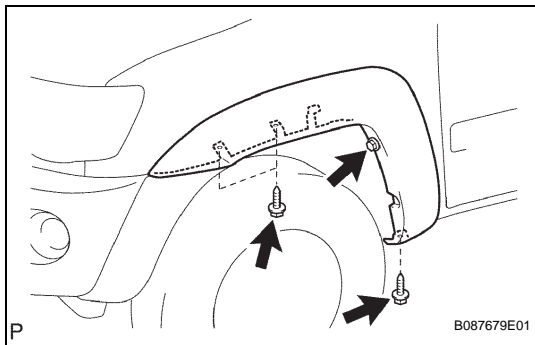

(b) for X-Runner:

- (1) Install new No. 2 body outside moulding pad in the position shown in the illustration.

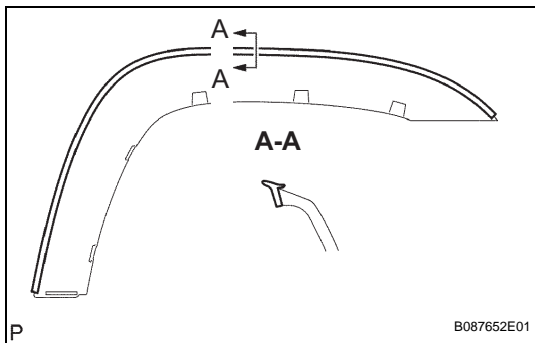

ET

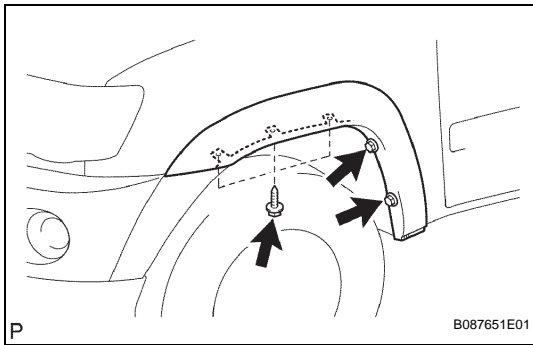

(2) Install the front fender wheel opening moulding with the 5 screws.

6. **INSTALL ROCKER PANEL MOULDING** (for X-Runner)
(See page [ET-41](#))
7. **INSTALL FRONT FENDER MUDGUARD** (for 4WD and Pre-Runner) (See page [ET-46](#))